



Product Change Notification - SYST-04GTSX528

Date:

05 Dec 2018

Product Category:

32-bit Microcontrollers

Affected CPNs:**Notification subject:**

ERRATA - PIC32MK Motor Control and General Purpose Errata and Data Sheet Clarification

Notification text:

SYST-04GTSX528

Microchip has released a new DeviceDoc for the PIC32MK Motor Control and General Purpose Errata and Data Sheet Clarification of devices. If you are using one of these devices please read the document located at [PIC32MK Motor Control and General Purpose Errata and Data Sheet Clarification](#).

Notification Status: Final

Description of Change: 1) Updated verbiage for Silicon Issue 39. (UART). 2) Added Silicon Issues: 55. (PMD Bits) and 56. (DAC) 3) Removed Silicon Issue 6. (Reserved) and 17. (Reserved).

Impacts to Data Sheet: None

Reason for Change: To Improve Productivity

Change Implementation Status: Complete

Date Document Changes Effective: 05 Dec 2018

NOTE: Please be advised that this is a change to the document only the product has not been changed.

Markings to Distinguish Revised from Unrevised Devices: N/A

Attachment(s):

[PIC32MK Motor Control and General Purpose Errata and Data Sheet Clarification](#)

Please contact your local [Microchip sales office](#) with questions or concerns regarding this notification.

Terms and Conditions:

If you wish to receive Microchip PCNs via email please register for our PCN email service at our [PCN home page](#) select register then fill in the required fields. You will find instructions about registering for Microchips PCN email service in the [PCN FAQ](#) section.

If you wish to change your PCN profile, including opt out, please go to the [PCN home page](#) select login and sign into your myMicrochip account. Select a profile option from the left navigation bar and make the applicable selections.

Affected Catalog Part Numbers (CPN)

PIC32MK0512GPD064-E/MR
PIC32MK0512GPD064-E/PT
PIC32MK0512GPD064-I/MR
PIC32MK0512GPD064-I/PT
PIC32MK0512GPD064T-E/MR
PIC32MK0512GPD064T-E/PT
PIC32MK0512GPD064T-I/MR
PIC32MK0512GPD064T-I/PT
PIC32MK0512GPD100-E/PT
PIC32MK0512GPD100-I/PT
PIC32MK0512GPD100T-E/PT
PIC32MK0512GPD100T-I/PT
PIC32MK0512GPE064-E/MR
PIC32MK0512GPE064-E/PT
PIC32MK0512GPE064-I/MR
PIC32MK0512GPE064-I/PT
PIC32MK0512GPE064T-E/MR
PIC32MK0512GPE064T-E/PT
PIC32MK0512GPE064T-I/MR
PIC32MK0512GPE064T-I/PT
PIC32MK0512GPE100-E/PT
PIC32MK0512GPE100-I/PT
PIC32MK0512GPE100T-E/PT
PIC32MK0512GPE100T-I/PT
PIC32MK0512MCF064-E/MR
PIC32MK0512MCF064-E/PT
PIC32MK0512MCF064-I/MR
PIC32MK0512MCF064-I/PT
PIC32MK0512MCF064T-E/MR
PIC32MK0512MCF064T-E/PT
PIC32MK0512MCF064T-I/MR
PIC32MK0512MCF064T-I/PT
PIC32MK0512MCF100-E/PT
PIC32MK0512MCF100-I/PT
PIC32MK0512MCF100T-E/PT
PIC32MK0512MCF100T-I/PT
PIC32MK1024GPD064-E/MR
PIC32MK1024GPD064-E/PT
PIC32MK1024GPD064-I/MR
PIC32MK1024GPD064-I/PT
PIC32MK1024GPD064T-E/MR
PIC32MK1024GPD064T-E/PT
PIC32MK1024GPD064T-I/MR
PIC32MK1024GPD064T-I/PT
PIC32MK1024GPD100-E/PT
PIC32MK1024GPD100-I/PT

PIC32MK1024GPD100T-E/PT
PIC32MK1024GPD100T-I/PT
PIC32MK1024GPE064-E/MR
PIC32MK1024GPE064-E/PT
PIC32MK1024GPE064-I/MR
PIC32MK1024GPE064-I/PT
PIC32MK1024GPE064T-E/MR
PIC32MK1024GPE064T-E/PT
PIC32MK1024GPE064T-I/MR
PIC32MK1024GPE064T-I/PT
PIC32MK1024GPE100-E/PT
PIC32MK1024GPE100-I/PT
PIC32MK1024GPE100T-E/PT
PIC32MK1024GPE100T-I/PT
PIC32MK1024MCF064-E/MR
PIC32MK1024MCF064-E/PT
PIC32MK1024MCF064-I/MR
PIC32MK1024MCF064-I/PT
PIC32MK1024MCF064T-E/MR
PIC32MK1024MCF064T-E/PT
PIC32MK1024MCF064T-I/MR
PIC32MK1024MCF064T-I/PT
PIC32MK1024MCF100-E/PT
PIC32MK1024MCF100-I/PT
PIC32MK1024MCF100T-E/PT
PIC32MK1024MCF100T-I/PT

PIC32MK General Purpose and Motor Control (GP/MC) Silicon Errata and Data Sheet Clarification

The PIC32MK General Purpose and Motor Control (GP/MC) family of devices that you have received conform functionally to the current Device Data Sheet (DS60001402E), except for the anomalies described in this document.

The silicon issues discussed in the following pages are for silicon revisions with the Device and Revision IDs listed in [Table 1](#). The silicon issues are summarized in [Table 2](#).

The errata described in this document will be addressed in future revisions of the PIC32MK General Purpose and Motor Control (GP/MC) family silicon.

Note: This document summarizes all silicon errata issues from all revisions of silicon, previous and current. Only the issues indicated in the last column of [Table 2](#) apply to the current silicon revision (**A2**).

Data Sheet clarifications and corrections (if applicable) start on [page 18](#) following the discussion of silicon issues.

The silicon revision level can be identified using the current version of MPLAB® X IDE and Microchip's programmers, debuggers, and emulation tools, which are available at the Microchip corporate web site (www.microchip.com).

For example, to identify the silicon revision level using MPLAB X IDE in conjunction with a hardware debugger:

1. Using the appropriate interface, connect the device to the hardware debugger.
2. Open an MPLAB X IDE project.
3. Configure the MPLAB X IDE project for the appropriate device and hardware debugger.
4. Select *Window > Dashboard*, and then click the **Refresh Debug Tool Status** icon ().
5. The part number and the Device and Revision ID values appear in the **Output** window.

Note: If you are unable to extract the silicon revision level, please contact your local Microchip sales office for assistance.

The Device and Revision ID values for the various PIC32MK General Purpose and Motor Control (GP/MC) family silicon revisions are shown in [Table 1](#).

Part Number	Device ID ⁽¹⁾	Revision ID for Silicon Revision ⁽¹⁾	
		A1	A2
PIC32MK1024MCF100	0x6201053	0x1	0x2
PIC32MK1024MCF064	0x6202053		
PIC32MK0512MCF100	0x6204053		
PIC32MK0512MCF064	0x6205053		
PIC32MK1024GPE100	0x6207053		
PIC32MK1024GPE064	0x6208053		
PIC32MK0512GPE100	0x620A053		
PIC32MK0512GPE064	0x620B053		
PIC32MK1024GPD100	0x620D053		
PIC32MK1024GPD064	0x620E053		
PIC32MK0512GPD100	0x6210053		
PIC32MK0512GPD064	0x6211053		

Note 1: Refer to the “**Memory Organization**” and “**Special Features**” chapters in the current Device Data Sheet (DS60001402E) for detailed information on Device and Revision IDs for your specific device.

PIC32MK GP/MC Family

Module	Feature	Item	Issue Summary	Affected Revisions ⁽¹⁾	
				A1	A2
Primary Oscillator	Posc	Primary Oscillator	Crystal primary oscillator (Posc) supports reduced operating range with restrictions.	X	X
Secondary Oscillator	Sosc	Secondary Oscillator	The Secondary Oscillator (Sosc) does not support crystal operation.	X	X
Clocks	PBCLK6	Clocks	PBCLK6 defaults to 1:2 instead of 1:4.	X	X
FSCM	Clock Fail	FSCM	Device falls back to LPRC instead of FRC on FSCM event.	X	X
VBAT	VBAT	VBAT	VBAT is not functional.	X	X
Reserved	-	Reserved	-	-	-
ADC	Level Trigger	ADC	The ADC level trigger will not perform burst conversions in Debug mode.	X	X
ADC	Turbo Mode	ADC	Turbo mode is not functional when two channels are linked for the purpose of increasing effective throughput.	X	X
ADC	DNL	ADC	In Differential mode, DNL for code 3072 is not within specification.	X	X
ADC	AN26	ADC	ADC input AN26 is not functional.	X	X
ADC	Scan	ADC	Scan list conversion will restart without finishing current scan list if new trigger occurs before scan completion with ADC7.	X	X
	Scan		Shared ADC7 has high Offset and Gain Error in Scan mode.	X	X
Op amp	Op amp	Op amp	Enabling an Op amp output control bit disables respective comparators output pin function if also enabled but comparator output status bit is still functional.	X	X
Op amp	Op amp	Op amp	Op amp output is always enabled regardless of output enable control bit if OPAMP is enabled.	X	X
Op amp	Op amp PGA Mode	Op amp	When used in PGA Unity Gain mode, an Op amp continues to function despite being disabled (i.e., AMPMOD = 0).	X	X
Op amp	Op amp PGA Mode	Op amp	Op amps in Unity Gain mode (i.e., ENPGAx bit (CFGCON2<4, 2:0> = 1) are non-functional.	X	X
Op amp	PSRR	Op amp	Op amp does not meet PSRR electrical specification.	X	X
Reserved	-	Reserved	-	-	-
Op amp	CMRR	Op amp	Op amps do not meet CMRR specification.	X	X
Op amp	Gain Margin	Op amp	Op amps do not meet gain margin specification.	X	X
DAC	INL	DAC	The DACs do not meet INL specification at AVDD less than 3V, and TA is greater than +85°C.	X	X
DAC	DNL	DAC	The DACs do not meet DNL specification at AVDD less than 3V.	X	X

Note 1: Only those issues indicated in the last column apply to the current silicon revision.

PIC32MK GP/MC Family

Module	Feature	Item	Issue Summary	Affected Revisions ⁽¹⁾	
				A1	A2
Timer1	Counter Async	Timer1	Timer1 in Asynchronous External Counter mode does not reflect the first count from an external ext T1CK input.	X	X
Timer1	Sleep Async	Timer1	TMR1 register of Timer1 in Asynchronous mode remains at initial set value of five external clock pulses after wake-up from Sleep mode.	X	X
Timer1	Sleep Async	Timer1	Back-to-back writes to the TMR1 register are not allowed for four PBCLK2 cycles.	X	X
I/O	RTCC	I/O	RTCC alarm output driver does not return to default/reset state on deep sleep wake-up through MCLR.	X	X
Deep Sleep	I/O	Deep Sleep	Deep Sleep mode is non functional.	X	X
RCON	Register	RCON	RCON status bits, VBPOR, PORIO, PORCORE, and VBAT, are inconsistent and cannot be used.	X	X
Sleep	IPD	Sleep	3 mA increase in sleep when PB5DIV is disabled.	X	X
Sleep	IPD	Sleep	Increase in sleep IPD current if USB pins D+ and D- are floating.	X	X
PMP	Status Flags	PMP	PMP input buffer full flag IB0F and out buffer underflow OBUF are set as soon as PMP is turned ON in Slave mode, when TTLEN = 1.	X	X
PMP	Slave Mode	PMP	CS is deasserting before RD in Slave mode.	X	X
CTMU	Triggers	CTMU	Edge Sequencing mode (EDGSEQEN (CTMUCON<2>)) triggers are not functional	X	X
CTMU	TGEN	CTMU	When the TGEN bit is set, manual current sourcing (i.e., setting the EDG1STAT bit) from CTMU is not possible.	X	X
ICAP	Debug	ICAP	Debug breakpoints are not supported when using Input Capture with DMA.	X	X
PWM	Time Base	PWM	Leading-edge Blanking (LED) in XPRES mode, XPRES bit (PWMCONx<2>) = 1, is not functional.	X	X
PWM	I/O	PWM	Alternate pin and I/O functions on unused PWM channels do not function when the PWM module is enabled.	X	X
PWM	LEB	PWM	Incorrect LEB trigger applied if dead time is enabled.	X	X
PWM	Interrupts	PWM	Multiple PWM Interrupts can occur for a single TRGIF, PWMLIF, and PWMHIF interrupt event, which causes the ISR to be re-executed multiple times if the PWM prescaler (i.e., PCLKDIV<2:0> bits (PTCON<6:4>)) or SCLKDIV<2:0> bits (STCON<6:4>) are greater than 5.	X	X

Note 1: Only those issues indicated in the last column apply to the current silicon revision.

PIC32MK GP/MC Family

Module	Feature	Item	Issue Summary	Affected Revisions ⁽¹⁾	
				A1	A2
UART	TX/RX Interrupt	UART	When UTXISEL<1:0> bits (UxSTA<15:14>) = 0b00, the UART Transmit Interrupt is generated and asserted while the transmit buffer contains one empty space. No interrupt is generated if the transmit buffer has more than one empty space. When URXISEL<1:0> bits (UxSTA<7:6>) = 0b00, the UART Receiver Interrupt is generated and asserted while the receive buffer has one character. No interrupt is generated if the receive buffer has more than one character.	X	X
UART	TX Interrupt	UART	A UART Transmit Interrupt (UTXISEL<1:0> bits = '0b01) is generated, but does not remain asserted when all of the characters have been transmitted.	X	X
UART	TX Interrupt	UART	A UART Transmit Interrupt (UTXISEL<1:0> bits = '0b10) is generated but does not remain asserted while the transmit buffer is empty.	X	X
UART	RX Interrupt	UART	The UART Receive Interrupt flag (URXISEL<1:0> bits = '0b01) is asserted only when the receive buffer equals one-half full and not when the receive buffer is greater than one-half full.	X	X
UART	RX Interrupt	UART	The UART Receive Interrupt Flag bit (URXISEL<1:0> bits = '0b10) is asserted only when the receive buffer equals three-quarters full and not when the receive buffer is greater than three-quarters full.	X	X
UART	High Speed Mode	UART	The UART Stop bit duration is shorter than expected in High-Speed mode (UxMODE.BRGH =1) for baud rates less than 7.5 MBPS.	X	X
CAN	Interrupt	CAN	The CAN Wake Interrupt Flag bit, WAKIF (CxINT<14>), is set even when the CAN module is disabled.	X	X
Deadman Timer (DMT)	Reset	Deadman Timer (DMT)	The Deadman Timer module does not cause a Non-maskable Interrupt (NMI) on a BAD1, BAD2, or DMTEVENT.	X	X
Watchdog Timer (WDT)	WDT	Watchdog Timer (WDT)	Multiple valid key writes can be performed outside the Watchdog Timer window before a Reset occurs instead of the required single write.	X	X
ICSP	TDO	ICSP	The TDO pin becomes an output and toggles while programming on any of the ICSP PGECx/PGEDx pair.	X	X
V _{IH}	Input Specification	V _{IH}	V _{IH} (MIN) does not meet the electrical specification of (0.65 * V _{DD}), but instead V _{IH} (MIN) = (0.8 * V _{DD}).	X	X

Note 1: Only those issues indicated in the last column apply to the current silicon revision.

PIC32MK GP/MC Family

Module	Feature	Item	Issue Summary	Affected Revisions ⁽¹⁾	
				A1	A2
Cache	Exception	Cache	A Data Bus Error Exception can occur when prefetch cache is enabled (PREFEN<1:0> bits (CHECON<5:4>) = '0b01).	X	
BOR	POR	BOR	On a BOR event, and when the BORSEL bit (DEVCFG2<29>) = 0, the POR Status bit (RCON<1>) may also be erroneously set.	X	X
BOR	Reset	BOR	On a BOR event, VPOR < VDD < VBOR, a Reset is not generated when the BOR threshold is reached. System clocks will stop with all I/O pins function frozen in their present state until either VDD falls to VPOR or VDD returns to above VBOR.	X	
SPI2	PPS	SPI2	The SPI SS2R PPS register cannot be read nor used with bit instruction of the form SS2Rbits.SS2R as it is a read-modify-write command.	X	X
DMA	R/W access to a peripheral	DMA	The CPU and DMA controller must not be allowed to simultaneously attempt access to the same peripheral bus.	X	X
PMD Bits	PMD Bits	PMD Bits	Setting the PMD bit for DMA peripheral (PMD7<4>) does not disable clock to DMA peripheral.	X	X
DAC	Output	DAC	A glitch may be observed at the DAC output, outside of DAC settling time specifications, when Peripheral Bus Clock 2 (PBCLK2) < 15 MHz.	X	X

Note 1: Only those issues indicated in the last column apply to the current silicon revision.

PIC32MK GP/MC Family

Silicon Errata Issues

Note 1: This document summarizes all silicon errata issues from all revisions of silicon, previous as well as current. The table provided in each issue indicates which issues exist for a particular revision of silicon.

2: The following applies to the Affected Silicon Revision tables in each silicon issue:

- An 'X' indicates the issue is present in this revision of silicon.
- Shaded cells with an Em dash ('—') indicate that this silicon revision does not exist for this issue.
- Blank cells indicate an issue has been corrected or does not exist in this revision of silicon.

1. Module: Primary Oscillator

The POSC supports only specific crystal operation as provided in [Table 1](#).

Work around 1

The Primary Oscillator (POSC) has been characterized to operate at 8 MHz and 12 MHz when the circuit shown in [Figure 1](#) is implemented and the operating conditions provided in [Table 1](#) are met.

FIGURE 1: POSC CRYSTAL CIRCUIT

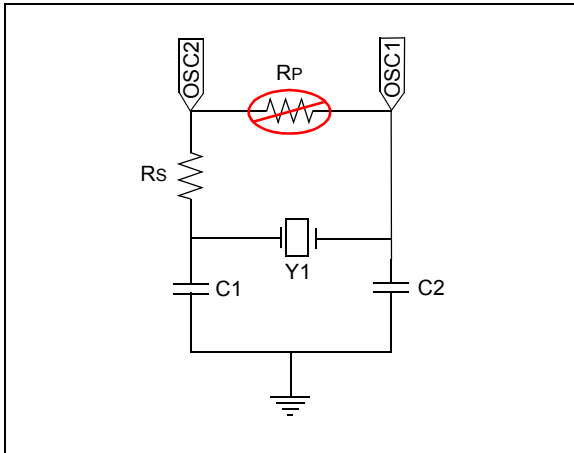

TABLE 1: CRYSTAL SPECIFICATIONS

Crystal Frequency (see Note 1)	Series Resistor Rs	POSC Gain Setting POSCGAIN<1:0> (DEVCFG0<20:19>)	POSC Boost Setting POSCBOOST (DEVCFG0<21>)
8 MHz	2 kΩ	'0b00 (GAIN_0)	'0b1
12 MHz	1 kΩ	'0b00 (GAIN_0)	'0b1
24 MHz ⁽³⁾	0	'0b00 (GAIN_0)	'0b1

- Note 1:** Using any other crystal frequency will require special component selection and characterization.
- 2:** A parallel resistor (Rp) should not be used to increase the gain of the POSC.
- 3:** Only 24 MHz crystals with a Mfg ESR ≤ 40Ω.

Work around 2

Alternatively, use an external clock or the Internal FRC Oscillator. Communication interfaces, such as CAN, USB, etc., with tighter clock accuracy requirements will not function with the FRC as clock source.

Affected Silicon Revisions

A1	A2						
X	X						

2. Module: Secondary Oscillator

A crystal oscillator cannot be used as the input to the Secondary Oscillator (SOSC) pins, SOSCI and SOSCO.

Work around

Use an external clock source (32,768 Hz) applied to the SOSCO pin with the FSOSCEN bit (DEVCFG1<6>) set to '0' (i.e., the Sosc pin is disabled through the Configuration Word) for a real-time clock base; otherwise, use the internal LPRC for non-precision requirements.

Affected Silicon Revisions

A1	A2						
X	X						

PIC32MK GP/MC Family

3. Module: Clocks

The PB6DIV<6:0> (i.e., PBDIV<6:0> bits), default to `\0b0000001` (1:2) instead of `\0b0000011` (1:4). The max clock rate supported for the PBCLK6 bus is 30 MHz.

Work around

Set the PBDIV<6:0> bits = `\0b0000011` (i.e., 1:4) assuming a 120 MHz SYSCLK. This is a register that requires an unlock sequence.

Affected Silicon Revisions

A1	A2						
X	X						

4. Module: FSCM

When the FCKSM<1:0> bits (DEVCFG1<15:14>) = `\0b1x`, clock fail monitoring is enabled, and a clock fail is detected. The SYSCLK source switches to the LPRC instead of the FRC as intended.

Work around

If the user has clock software clock switching enabled, FCKSM<1:0> = `\0b11`, they can perform a software clock switch to the FRC instead.

Affected Silicon Revisions

A1	A2						
X	X						

5. Module: VBAT

The VBAT pin is non-functional and it must be connected to VDD.

Work around

None.

Affected Silicon Revisions

A1	A2						
X	X						

6. Module: Reserved

Affected Silicon Revisions

A1	A2						

7. Module: ADC

The ADC level trigger, ADCTRGx register = `\0b00010`, will not perform burst conversions in Debug mode.

Work around

Do not use Debug mode with the ADC level triggers.

Affected Silicon Revisions

A1	A2						
X	X						

8. Module: ADC

Turbo mode, TRBEN bit (ADCCON1<31>) = 1, is not functional when two channels are linked for increasing effective throughput.

Work around

The user can still increase the effective throughput rate by interleaving ADC cores and trigger sources by connecting multiple dedicated high-speed ADCs to the same analog input and staggering the respective ADCx core triggers appropriately.

TABLE 2: INTERLEAVED ADC PERFORMANCE VDD > 2.5V

Number of Interleaved ADC (12-bit mode)	Minimum TAD Sampling Time (SAMC)	Maximum Effective Sampling Rate (in Msps)
2	13	4.615
3	7	8.57
4	5	12
5	4	15
6	3	20

Affected Silicon Revisions

A1	A2						
X	X						

9. Module: ADC

In Differential mode, code 3072 has a DNL of +3.

Work around

None.

Affected Silicon Revisions

A1	A2						
X	X						

PIC32MK GP/MC Family

10. Module: ADC

ADC input AN26 is not functional.

Work around

None.

Affected Silicon Revisions

A1	A2						
X	X						

11. Module: ADC

Scan list conversions defined in the ADCCSS1 register will restart without finishing the current scan list and do not generate an EOSRDY bit (ADCCON2<29>) end of scan interrupt status if a new trigger event from the STRGSRC<4:0> bits (ADCCON1<20:16>) trigger source occurs before the scan list completion on the shared ADC7 core.

Work around

Ensure that the STRGSRC<4:0> bits trigger source repetition rate > (sample + conversion) times of the sum of all ANx inputs defined in the ADCCSS1/ADCCSS2 registers.

Affected Silicon Revisions

A1	A2						
X	X						

Shared ADC7 has high Offset and Gain Error up to 38 Lsb in ADC7 Scan mode, as defined in the ADCCSS1/ADCCSS2 registers.

Work around

Increase the user-defined SAMC<9:0> bits (ADCCON2<25:16>) sample time register value by 4 TAD. This will reduce the ADC7 throughput that the user must consider, but it will reduce the gain and offset to less than 4 Lsb in 12-bit mode.

Affected Silicon Revisions

A1	A2						
X	X						

12. Module: Op amp

Enabling the Op amp Output Enable bit, OAO (CMxCON<11>) = 1, disables the respective Comparator's output pin function, CxOUT, on a different pin entirely if it was enabled, COE bit (CMxCON<14>); however, the Comparator Output Status is still functional.

Work around

None. The same Op amp/Comparator outputs cannot be enabled simultaneously.

Affected Silicon Revisions

A1	A2						
X	X						

13. Module: Op amp

When the AMPMOD bit (CMxCON<10>) = 1 (the Op amp is enabled), the Op amp output pin is active regardless of the state of the OAO bit (CMxCON<11>) Op amp output pin enable.

Work around

If the user does not want the Op amp output pin to be active, do not enable the Op amp until required.

Affected Silicon Revisions

A1	A2						
X	X						

14. Module: Op amp

When used in 1x Unity Gain Buffer mode, an Op amp continues to function despite being disabled, (i.e., AMPMOD bit (CMxCON<10>) = 0).

Work around

None.

Affected Silicon Revisions

A1	A2						
X	X						

PIC32MK GP/MC Family

15. Module: Op amp

Op amps in Unity Gain mode (i.e., ENPGAx bit (CFGCON2<20, 18, 17, 16>) = 1) are non-functional.

Work around

Do not use Op amp Unity Gain mode or use external 8x resistor signal attenuation network to Op amp input and then use op amp with 8x gain for net 1x signal gain.

Affected Silicon Revisions

A1	A2						
X	X						

16. Module: Op amp

Op amp minimum PSRR electrical spec is -39 db versus -75 db typical.

Work around

None.

Affected Silicon Revisions

A1	A2						
X	X						

17. Module: Reserved

Affected Silicon Revisions

A1	A2						

18. Module: Op amp

Op amps CMRR is < 28 db at input common mode voltages between 0.4V-0.9V, which is less than the electrical specification of 70 db minimum.

Work around

None.

Affected Silicon Revisions

A1	A2						
X	X						

19. Module: Op amp

Op amps do not meet the typical gain margin specification of 20, but are instead 15.

Work around

None.

Affected Silicon Revisions

A1	A2						
X	X						

20. Module: DAC

DACs when sourcing IOUT(MAX) = -1.5 mA, do not meet INL ±4 Lsb specification when AVDD < 3.0V. and TA > 85°C.

Work around

Do not use DACs to source > -0.75 mA at 2.6V < AVDD < 3.0V.

Affected Silicon Revisions

A1	A2						
X	X						

21. Module: DAC

DACs do not meet DNL -1 Lsb min specification when AVDD < 3.0V. Worst case is -1.5 Lsb at 2.2V.

Work around

None.

Affected Silicon Revisions

A1	A2						
X	X						

22. Module: Timer1

Timer1 in Asynchronous External Counter mode, (i.e., TCS bit (T1CON<1> = 1, TSYNC bit (T1CON<2> = 0, and TECS<1:0> bits (T1CON<9:8>) are greater than '0b01) does not reflect the first count from an external T1CK input.

Work around

None.

Affected Silicon Revisions

A1	A2						
X	X						

PIC32MK GP/MC Family

23. Module: Timer1

The TMR1 register of Timer1 in Asynchronous mode (i.e., TCS bit (T1CON<1> = 1, TSYNC bit (T1CON<2> = 0, and TECS<1:0> bits (T1CON<9:8>) are greater than '0b01), remains at initial set value for 5 external clock pulses after wake up from Sleep mode

Work around

None.

Affected Silicon Revisions

A1	A2						
X	X						

24. Module: Timer1

Back-to-back writes to the TMR1 register are not allowed for four PBCLK2 cycles.

Work around

Wait for four PBCLK2 cycles before attempting a second write to the TMR1 register.

Affected Silicon Revisions

A1	A2						
X	X						

25. Module: I/O

If the I/O function is configured for RTCC alarm output driver, it does not return to default/Reset input high-Z state on wake-up from Deep Sleep mode through MCLR.

Work around

None.

Affected Silicon Revisions

A1	A2						
X	X						

26. Module: Deep Sleep

Deep-Sleep mode is non-functional.

Work around

None.

Affected Silicon Revisions

A1	A2						
X	X						

27. Module: RCON

The RCON register status bits, VBPOR, PORIO, PORCORE, and VBAT, are inconsistent and cannot be used.

Work around

None.

Affected Silicon Revisions

A1	A2						
X	X						

28. Module: Sleep

If the ON bit (PB5DIV<15>) = 0, and PBCLK5 is disabled, there is a 3 mA increase in Sleep IPD current.

Work around

Do not disable PBCLK5 before entering Sleep mode.

Affected Silicon Revisions

A1	A2						
X	X						

29. Module: Sleep

There is a 170 μ A increase in Sleep IPD current if USB pins D+ and D- are unused and left floating.

Work around

Add 50k pull-downs on D+ and D-, and tie VUSB3V3 to VDD.

Affected Silicon Revisions

A1	A2						
X	X						

30. Module: PMP

The PMP Input Buffer 'x' Status Full bit, IB0F (PMSTAT<8>), and Output Buffer Underflow Status bit, OBUF (PMSTAT<6>), are set as soon as the PMP is turned ON in Slave mode, when TTLLEN = 1.

Work around

After PMP initial initialization is complete, and before PMP and interrupts are enabled, clear these bits in user software.

Affected Silicon Revisions

A1	A2						
X	X						

PIC32MK GP/MC Family

31. Module: PMP

CS is deasserting before RD in Slave mode. Slave mode is defeatured.

Work around

None.

Affected Silicon Revisions

A1	A2							
X	X							

32. Module: CTMU

Edge Sequencing mode, (EDGSEQEN bit (CTMUCON<2>)), and Edge mode are not functional.

Work around

Use level modes.

Affected Silicon Revisions

A1	A2							
X	X							

33. Module: CTMU

When the TGEN bit is set, manual current sourcing (i.e., setting the EDG1STAT bit) from the CTMU is not possible.

Work around

None.

Affected Silicon Revisions

A1	A2							
X	X							

34. Module: ICAP

Debug breakpoints are not supported when using Input Capture with DMA.

Work around

None.

Affected Silicon Revisions

A1	A2							
X	X							

35. Module: PWM

Leading edge blanking in XPRES mode, XPRES bit (PWMCONx<2>) = 1, is not functional.

Work around

None.

Affected Silicon Revisions

A1	A2							
X	X							

36. Module: PWM

The PWM module does not relinquish control of the PWM pins even if they are not enabled, (i.e., PENH bit (IOCONx<15>) = 0 and PENL bit (IOCON<14>) = 0).

Work around

Disable corresponding unused user PWM channels by setting the appropriate PWMxMD bit in the PMD4 register = 1.

Affected Silicon Revisions

A1	A2							
X	X							

37. Module: PWM

Leading-edge Blanking (LEB) trigger is not applied at the correct time if dead time is enabled. The trigger is applied before the dead time when it should be applied after the dead time to coincide with the actual dead time delayed PWM signal transition.

Work around

Make the leading edge blanking time LEBDLYx<11:0> (i.e., LED<11:0> bits) equal to the desired leading edge blanking time, and the respective dead time value

Affected Silicon Revisions

A1	A2							
X	X							

PIC32MK GP/MC Family

38. Module: PWM

Multiple PWM Interrupts occur for single TRGIF, PWMLIF, and PWMHIF interrupt events. The ISR is re-executed multiple times if the PWM prescaler bits (PTCON<6:4>) (i.e., PCLKDIV<2:0>) or SCLKDIV<2:0> bits (i.e. STCON<6:4>) are greater than 5.

Work around

Insure that the PCLKDIV<2:0> bits and the STCON< 2:0> bits are less than 5.

Affected Silicon Revisions

A1	A2						
X	X						

39. Module: UART

When UTXISEL<1:0> bits (UxSTA<15:14>) = 0b00, the UART Transmit Interrupt is generated and asserted while the transmit buffer contains one empty space. No interrupt is generated if the transmit buffer has many empty space. When URXISEL<1:0> bits (UxSTA<7:6>) = 0b00, the UART Receiver Interrupt is generated and asserted while the receive buffer has one character. No interrupt is generated if the receive buffer has many character.

Work around

None.

Affected Silicon Revisions

A1	A2						
X	X						

40. Module: UART

A UART Transmit Interrupt (UTXISEL<1:0> bits = '0b01) is generated but does not remain asserted when all of the characters have been transmitted. Once the IFSx bit is cleared by the user, it does not remain asserted even while all characters have been transmitted. This behavior compounded with finite interrupt latency can create a race condition amongst subsequent TX interrupts.

Work around

To avoid the race condition, clear the UARTx IFSx flag before writing a new value to the TX Buffer, UxTXREG, in the ISR.

Affected Silicon Revisions

A1	A2						
X	X						

41. Module: UART

UART Transmit UTXISEL<1:0> bits = '0b10 Interrupt is generated but does not remain asserted while the transmit buffer is empty. Once the IFS bit is cleared by the user, it does not remain asserted even while transmit buffer is empty. This behavior compounded with finite interrupt latency can create a race condition amongst subsequent TX interrupts.

Work around

To avoid the race condition, clear the UARTx IFS flag before writing a new value to the TX Buffer, UxTXREG, in the ISR.

Affected Silicon Revisions

A1	A2						
X	X						

42. Module: UART

The UART Receive Interrupt Flag (URXISEL<1:0> bits = '0b01) is asserted only when the receive buffer equals one-half full and not when the receive buffer is greater than one-half full.

Work around

Before exiting the UART RX ISR, ensure all the contents of the RX Buffer have been read, by reading the contents of the RX Buffer in the ISR until the URXDA bit (UxSTA<0>) is cleared.

Affected Silicon Revisions

A1	A2						
X	X						

43. Module: UART

The UART Receive Interrupt Flag bit (URXISEL<1:0> bits = '0b10) is asserted only when the receive buffer equals three-quarters full and not when the receive buffer is greater than three-quarters full.

Work around

Before exiting the UART RX ISR, ensure the entire contents of the RX Buffer have been read by reading the contents of RX Buffer in the ISR until the URXDA bit (UxSTA<10>) bit is cleared.

Affected Silicon Revisions

A1	A2						
X	X						

PIC32MK GP/MC Family

44. Module: UART

The UART TX Stop bit duration is shorter than the expected in High-Speed mode (BRGH (UxMODE<3>) = 1) for baud rates less than 7.5 MBPS.

Work around

For baud rates less than 7.5 MBPS, operate the UART in Standard-Speed mode, that is, BRGH (UxMODE<3>) = 0. For baud rates greater than 7.5 MBPS operate the UART in High-Speed mode, that is, BRGH (UxMODE<3>) = 1.

Affected Silicon Revisions

A1	A2							
X	X							

45. Module: CAN

The CAN Wake Interrupt Flag bit, WAKIF (CxINT<14>), is set even when the CAN module is disabled.

Work around

During CAN initialization, and before enabling the CAN peripheral, clear the WAKIF bit in user code.

Affected Silicon Revisions

A1	A2							
X	X							

46. Module: Deadman Timer (DMT)

The Deadman Timer module does not cause a Non-maskable Interrupt (NMI) on a BAD1, BAD2, or DMTEVENT.

Work around

None.

Affected Silicon Revisions

A1	A2							
X	X							

47. Module: Watchdog Timer (WDT)

Multiple valid key writes can be performed outside the Watchdog Timer window before a Reset occurs instead of the required single write.

Work around

None.

Affected Silicon Revisions

A1	A2							
X	X							

48. Module: ICSP

Regardless of other functions shared on the TDO pin, the TDO function becomes an active output and toggles while programming on any ICSP PGECx/PGEDx pair.

Work around

None.

Affected Silicon Revisions

A1	A2							
X	X							

49. Module: VIH

VIH(MIN) does not meet the electrical specification of $(0.65 * VDD)$, but is instead $VIH(MIN) = (0.8 * VDD)$.

Work around

Although VIH is greater than VOH(MIN) = 2.4V, VOH(MIN) is a function of IOH(MAX). If the application does not load the VIH input source signal by more than IOH(MAX) by 50%, there should be no issues.

Affected Silicon Revisions

A1	A2							
X	X							

50. Module: Cache

A Data Bus Error Exception can occur when prefetch cache is enabled, (PREFEN<1:0>) bits (CHECON<5:4> = '0b01).

Work around

Users must ensure that predictive prefetch cache is disabled by setting the PREFEN<1:0> bits = '0b00.

Affected Silicon Revisions

A1	A2							
X								

PIC32MK GP/MC Family

51. Module: BOR

On a BOR event, and when the BORSEL bit (DEVCFG2<29>) = 0, the POR Status bit (RCON<0>) may also be erroneously set.

Work around

None.

Affected Silicon Revisions

A1	A2						
X	X						

52. Module: BOR

On a BOR event, $V_{POR} < V_{DD} < V_{BOR}$, a Reset is not generated when the BOR threshold is reached. System clocks will stop with all I/O pins functions frozen in their present state until either VDD falls to V_{POR} or VDD returns to above V_{BOR} . The user must assess if this VDD brown-out condition and the resulting frozen I/O pin state has an adverse effect on their application (UART, PWM, I/O, OC, etc.).

Work around 1

Use an external Reset supervisor/monitor (see Figure 2). Some LDO regulators, as listed in Table 4, have an embedded reset supervisor included. The required minimum reset trip voltage of the supervisor should be at least $(V_{BOR} + 0.5V)$ with the SMCLR bit (DEVCFG0<15>) = 0 and the BORSEL bit (DEVCFG2<29>) = 1 in the Configuration Words. This means that the minimum VDD operating voltage of the application needs to be above the reset supervisor maximum trip voltage at [Reset Trip (max) + 0.2V], (i.e. Application $V_{DD(MIN)} = \sim(V_{BOR} + 0.5V + 0.2V)$). The reset supervisor should have an open drain output so as not to interfere with the MPLAB programming/debug tools. This workaround assures that MCLR will generate an internal POR and reset the I/O pins before the V_{BOR} trip point.

Note: For Motor Control applications utilizing the PWM module, **only Work around 1 is recommended.**

PIC32MK GP/MC Family

Work around 2

If the application can sustain frozen I/O states for ~2.1 ms (UART, CAN, I/O, etc.), the application must enable the Deep Sleep Watchdog Timer and Clock Fail Monitor, based on the details provided in Table 3 and Table 4. If implemented correctly, after ~2.1 ms, a valid internal reset state is entered and the I/O pins are set to the device default Reset state.

TABLE 3: RESET SUPERVISOR/ VOLTAGE MONITOR

Part Number	Reset Trip	CPU $\overline{\text{MCLR}}$ Source
MIC803-26D2VC3	2.63v	Reset pin (Open Drain)

FIGURE 2: RESET SUPERVISOR CIRCUIT

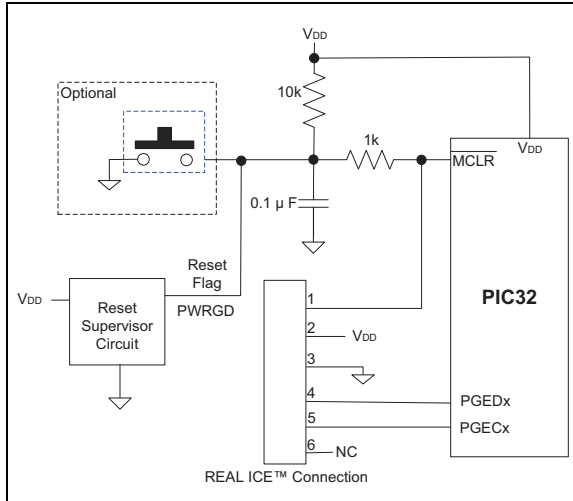

TABLE 4: LDO REGULATORS WITH EMBEDDED RESET SUPERVISOR

Part Number	Topology	V _{IN} (MAX)	V _{OUT}	I _{OUT}	Reset Trip	CPU $\overline{\text{MCLR}}$ Source
MIC5239-3.3YM	LDO	30V	3.3V	500mA	3.3V-5%	FLG pin (Open Drain)
MIC5239-3.3YMM						
MCP1725-3302E/MC	LDO	6V	3.3V	500mA	3.3V-10%	PWRGD pin (Open Drain)
MCP1727-3302E/MF	LDO	6V	3.3V	1500mA	3.3V-10%	PWRGD pin (Open Drain)

Affected Silicon Revisions

A1	A2							
X								

PIC32MK GP/MC Family

53. Module: SPI2

Reading the SPI2 SS2R PPS register will return indeterminate results. Therefore, also avoid using bit instruction of the form SS2Rbits.SS2R, as it is a read-modify-write command, which will corrupt the register value. Writes to the register or bit SET, CLR, or INV will function as expected.

Work around

Only use register write instruction forms to this register.

Affected Silicon Revisions

A1	A2						
X	X						

54. Module: DMA

A simultaneous access by the CPU and the DMA controller to the same peripheral bus may result in bus conflict and cause the CPU to stall indefinitely until a Reset. For example, if the CPU is accessing the TMR2 which is located on peripheral bus 2, then a DMA access to any peripheral on peripheral bus 2, such as UART1, may result in a bus conflict and cause the CPU to stall indefinitely until a Reset. See Figure 1-1 "PIC32MK GP/MC Family Block Diagram" in the data sheet to determine which peripherals share the same peripheral bus.

This issue is limited to the CPU and the DMA controller accessing the same peripheral bus only. There are no bus conflict issues when the CPU and the DMA controller are simultaneously accessing SRAM memory. Furthermore, peripherals such as, ADC, CAN and USB OTG which have their independent DMA capabilities are not impacted by this issue as long as the destination is SRAM memory.

Work around

Avoid simultaneous CPU and DMA access to the same peripheral bus. If there is a possibility of an ongoing DMA transfer, ensure that the DMA transfers on that peripheral bus are disabled before the CPU attempts to access that peripheral bus. This includes interrupt service routines during which the CPU is attempting access to the interrupting peripheral on the same peripheral bus where there is a possibility of an ongoing DMA transfer.

Affected Silicon Revisions

A1	A2						
X	X						

55. Module: PMD Bits

Setting the PMD bit for DMA peripheral (PMD7<4>) does not disable the clock to DMA peripheral.

Work around

None.

Affected Silicon Revisions

A1	A2						
X	X						

56. Module: DAC

While making a DAC output update, a glitch may be observed at the DAC output, that is outside of DAC settling time specifications, for Peripheral Bus Clock 2 (PBCLK2) < 15 MHz. The glitch amplitude is larger for large step changes in the DAC output.

Work around

Maintain PBCLK2 above 15 MHz while using CDAC.

Affected Silicon Revisions

A1	A2							
X	X							

PIC32MK GP/MC Family

Data Sheet Clarifications

The following typographic corrections and clarifications are to be noted for the latest version of the device data sheet (DS60001402E):

<p>Note: Corrections are shown in bold. Where possible, the original bold text formatting has been removed for clarity.</p>

There are currently no Data Sheet Clarifications to report.

APPENDIX A: REVISION HISTORY

Rev A Document (3/2017)

Initial release of this document issued for Revision A1 silicon, which includes silicon issues 1. (Primary Oscillator), 2. (Secondary Oscillator), 3. (Clocks), 4. (FSCM), 5. (VBAT), 6. (VBAT), 7. (ADC), 8. (ADC), 9. (ADC), 10. (ADC), 11. (ADC), 12. (ADC), 13. (Op amp), 14. (Op amp), 15. (Op amp), 16. (Op amp), 17. (Op amp), 18. (Op amp), 19. (Op amp), 20. (Op amp), 21. (DAC), 22. (DAC), 23. (Timer1), 24. (Timer1), 25. (Timer1), 26. (I/O), 27. (Deep Sleep), 28. (RCON), 29. (Sleep), 30. (Sleep), 31. (PMP), 32. (PMP), 33. (CTMU), 34. (CTMU), 35. (ICAP), 36. (PWM), 37. (PWM), 38. (PWM), 39. (PWM), 40. (UART), 41. (UART), 42. (UART), 43. (UART), 44. (UART), 45. (Temperature Sensor), 46. (CAN), 47. (Deadman Timer (DMT)), 48. (WDT), 49. (ICSP), 50. (VIH), 51. (Cache), 52. (BOR), 53. (BOR).

Rev B Document (7/2017)

Updated silicon issue [UART](#) to Reserved.

Added Data Sheet Clarifications: [A \(Revision History\)](#), [2. \(Deep Sleep Max Current\)](#), [3. \(CTMU Temperature Sensor Graph\)](#), [\(The minimum BOR event on V_{DD} transition high-to-low voltage value, defined in parameter BO1a for\)](#).

Rev C Document (9/2017)

Updated for Revision A2 silicon.

Added silicon issue [53. \(SPI2\)](#).

Rev D Document (4/2018)

Add Silicon Issues [44. \(UART\)](#) and [54. \(DMA\)](#).

Added Data Sheet Clarifications: [\(The minimum BOR event on V_{DD} transition high-to-low voltage value, defined in parameter BO1a for\)](#).

Rev E Document (11/2018)

Updated verbiage for Silicon Issue [39. \(UART\)](#).

Added Silicon Issues: [55. \(PMD Bits\)](#) and [56. \(DAC\)](#)

Removed Silicon Issue [6. \(Reserved\)](#) and [17. \(Reserved\)](#).

PIC32MK GP/MC Family

NOTES:

Note the following details of the code protection feature on Microchip devices:

- Microchip products meet the specification contained in their particular Microchip Data Sheet.
- Microchip believes that its family of products is one of the most secure families of its kind on the market today, when used in the intended manner and under normal conditions.
- There are dishonest and possibly illegal methods used to breach the code protection feature. All of these methods, to our knowledge, require using the Microchip products in a manner outside the operating specifications contained in Microchip's Data Sheets. Most likely, the person doing so is engaged in theft of intellectual property.
- Microchip is willing to work with the customer who is concerned about the integrity of their code.
- Neither Microchip nor any other semiconductor manufacturer can guarantee the security of their code. Code protection does not mean that we are guaranteeing the product as “unbreakable.”

Code protection is constantly evolving. We at Microchip are committed to continuously improving the code protection features of our products. Attempts to break Microchip's code protection feature may be a violation of the Digital Millennium Copyright Act. If such acts allow unauthorized access to your software or other copyrighted work, you may have a right to sue for relief under that Act.

Information contained in this publication regarding device applications and the like is provided only for your convenience and may be superseded by updates. It is your responsibility to ensure that your application meets with your specifications. MICROCHIP MAKES NO REPRESENTATIONS OR WARRANTIES OF ANY KIND WHETHER EXPRESS OR IMPLIED, WRITTEN OR ORAL, STATUTORY OR OTHERWISE, RELATED TO THE INFORMATION, INCLUDING BUT NOT LIMITED TO ITS CONDITION, QUALITY, PERFORMANCE, MERCHANTABILITY OR FITNESS FOR PURPOSE. Microchip disclaims all liability arising from this information and its use. Use of Microchip devices in life support and/or safety applications is entirely at the buyer's risk, and the buyer agrees to defend, indemnify and hold harmless Microchip from any and all damages, claims, suits, or expenses resulting from such use. No licenses are conveyed, implicitly or otherwise, under any Microchip intellectual property rights unless otherwise stated.

Microchip received ISO/TS-16949:2009 certification for its worldwide headquarters, design and wafer fabrication facilities in Chandler and Tempe, Arizona; Gresham, Oregon and design centers in California and India. The Company's quality system processes and procedures are for its PIC® MCUs and dsPIC® DSCs, KEELOQ® code hopping devices, Serial EEPROMs, microperipherals, nonvolatile memory and analog products. In addition, Microchip's quality system for the design and manufacture of development systems is ISO 9001:2000 certified.

**QUALITY MANAGEMENT SYSTEM
CERTIFIED BY DNV
= ISO/TS 16949 =**

Trademarks

The Microchip name and logo, the Microchip logo, AnyRate, AVR, AVR logo, AVR Freaks, BitCloud, chipKIT, chipKIT logo, CryptoMemory, CryptoRF, dsPIC, FlashFlex, flexPWR, Helder, JukeBlox, KeeLoq, Kleer, LANCheck, LINK MD, maXStylus, maXTouch, MediaLB, megaAVR, MOST, MOST logo, MPLAB, OptoLyzer, PIC, picoPower, PICSTART, PIC32 logo, Prochip Designer, QTouch, SAM-BA, SpyNIC, SST, SST Logo, SuperFlash, tinyAVR, UNI/O, and XMEGA are registered trademarks of Microchip Technology Incorporated in the U.S.A. and other countries.

ClockWorks, The Embedded Control Solutions Company, EtherSynch, Hyper Speed Control, HyperLight Load, IntellIMOS, mTouch, Precision Edge, and Quiet-Wire are registered trademarks of Microchip Technology Incorporated in the U.S.A.

Adjacent Key Suppression, AKS, Analog-for-the-Digital Age, Any Capacitor, AnyIn, AnyOut, BodyCom, CodeGuard, CryptoAuthentication, CryptoAutomotive, CryptoCompanion, CryptoController, dsPICDEM, dsPICDEM.net, Dynamic Average Matching, DAM, ECAN, EtherGREEN, In-Circuit Serial Programming, ICSP, INICnet, Inter-Chip Connectivity, JitterBlocker, KleerNet, KleerNet logo, memBrain, Mindi, MiWi, motorBench, MPASM, MPF, MPLAB Certified logo, MPLIB, MPLINK, MultiTRAK, NetDetach, Omniscient Code Generation, PICDEM, PICDEM.net, PICKit, PICtail, PowerSmart, PureSilicon, QMatrix, REAL ICE, Ripple Blocker, SAM-ICE, Serial Quad I/O, SMART-I.S., SQI, SuperSwitcher, SuperSwitcher II, Total Endurance, TSHARC, USBCheck, VariSense, ViewSpan, WiperLock, Wireless DNA, and ZENA are trademarks of Microchip Technology Incorporated in the U.S.A. and other countries.

SQTP is a service mark of Microchip Technology Incorporated in the U.S.A.

Silicon Storage Technology is a registered trademark of Microchip Technology Inc. in other countries.

GestIC is a registered trademark of Microchip Technology Germany II GmbH & Co. KG, a subsidiary of Microchip Technology Inc., in other countries.

All other trademarks mentioned herein are property of their respective companies.

© 2018, Microchip Technology Incorporated, All Rights Reserved.
ISBN: 978-1-5224-3839-7



MICROCHIP

Worldwide Sales and Service

AMERICAS

Corporate Office
2355 West Chandler Blvd.
Chandler, AZ 85224-6199
Tel: 480-792-7200
Fax: 480-792-7277
Technical Support:
<http://www.microchip.com/support>
Web Address:
www.microchip.com

Atlanta

Duluth, GA
Tel: 678-957-9614
Fax: 678-957-1455

Austin, TX

Tel: 512-257-3370

Boston

Westborough, MA
Tel: 774-760-0087
Fax: 774-760-0088

Chicago

Itasca, IL
Tel: 630-285-0071
Fax: 630-285-0075

Dallas

Addison, TX
Tel: 972-818-7423
Fax: 972-818-2924

Detroit

Novi, MI
Tel: 248-848-4000

Houston, TX

Tel: 281-894-5983

Indianapolis

Noblesville, IN
Tel: 317-773-8323
Fax: 317-773-5453
Tel: 317-536-2380

Los Angeles

Mission Viejo, CA
Tel: 949-462-9523
Fax: 949-462-9608
Tel: 951-273-7800

Raleigh, NC

Tel: 919-844-7510

New York, NY

Tel: 631-435-6000

San Jose, CA

Tel: 408-735-9110
Tel: 408-436-4270

Canada - Toronto

Tel: 905-695-1980
Fax: 905-695-2078

ASIA/PACIFIC

Australia - Sydney
Tel: 61-2-9868-6733

China - Beijing
Tel: 86-10-8569-7000

China - Chengdu
Tel: 86-28-8665-5511

China - Chongqing
Tel: 86-23-8980-9588

China - Dongguan
Tel: 86-769-8702-9880

China - Guangzhou
Tel: 86-20-8755-8029

China - Hangzhou
Tel: 86-571-8792-8115

China - Hong Kong SAR
Tel: 852-2943-5100

China - Nanjing
Tel: 86-25-8473-2460

China - Qingdao
Tel: 86-532-8502-7355

China - Shanghai
Tel: 86-21-3326-8000

China - Shenyang
Tel: 86-24-2334-2829

China - Shenzhen
Tel: 86-755-8864-2200

China - Suzhou
Tel: 86-186-6233-1526

China - Wuhan
Tel: 86-27-5980-5300

China - Xian
Tel: 86-29-8833-7252

China - Xiamen
Tel: 86-592-2388138

China - Zhuhai
Tel: 86-756-3210040

ASIA/PACIFIC

India - Bangalore
Tel: 91-80-3090-4444

India - New Delhi
Tel: 91-11-4160-8631

India - Pune
Tel: 91-20-4121-0141

Japan - Osaka
Tel: 81-6-6152-7160

Japan - Tokyo
Tel: 81-3-6880-3770

Korea - Daegu
Tel: 82-53-744-4301

Korea - Seoul
Tel: 82-2-554-7200

Malaysia - Kuala Lumpur
Tel: 60-3-7651-7906

Malaysia - Penang
Tel: 60-4-227-8870

Philippines - Manila
Tel: 63-2-634-9065

Singapore
Tel: 65-6334-8870

Taiwan - Hsin Chu
Tel: 886-3-577-8366

Taiwan - Kaohsiung
Tel: 886-7-213-7830

Taiwan - Taipei
Tel: 886-2-2508-8600

Thailand - Bangkok
Tel: 66-2-694-1351

Vietnam - Ho Chi Minh
Tel: 84-28-5448-2100

EUROPE

Austria - Wels
Tel: 43-7242-2244-39
Fax: 43-7242-2244-393

Denmark - Copenhagen
Tel: 45-4450-2828
Fax: 45-4485-2829

Finland - Espoo
Tel: 358-9-4520-820

France - Paris
Tel: 33-1-69-53-63-20
Fax: 33-1-69-30-90-79

Germany - Garching
Tel: 49-8931-9700

Germany - Haan
Tel: 49-2129-3766400

Germany - Heilbronn
Tel: 49-7131-67-3636

Germany - Karlsruhe
Tel: 49-721-625370

Germany - Munich
Tel: 49-89-627-144-0
Fax: 49-89-627-144-44

Germany - Rosenheim
Tel: 49-8031-354-560

Israel - Ra'anana
Tel: 972-9-744-7705

Italy - Milan
Tel: 39-0331-742611
Fax: 39-0331-466781

Italy - Padova
Tel: 39-049-7625286

Netherlands - Drunen
Tel: 31-416-690399
Fax: 31-416-690340

Norway - Trondheim
Tel: 47-7288-4388

Poland - Warsaw
Tel: 48-22-3325737

Romania - Bucharest
Tel: 40-21-407-87-50

Spain - Madrid
Tel: 34-91-708-08-90
Fax: 34-91-708-08-91

Sweden - Gothenberg
Tel: 46-31-704-60-40

Sweden - Stockholm
Tel: 46-8-5090-4654

UK - Wokingham
Tel: 44-118-921-5800
Fax: 44-118-921-5820