

1 Products affected

Product hierarchy no. *				Part no.	SBU	Type / Description	Customer part no.
SBU	PG	PUG	Type				
02	005	016	0000001169	See list below	Power entry module	DD11	

*SBU (2-digit) / PG (3-digit) / PUG (3-digit) / Type (10-digit)

List of part numbers affected				
3-102-849	3-102-851	3-102-856	3-102-858	3-102-860
3-108-742	3-108-778	3-110-009	3-115-071	DD11.0111.1110
DD11.0111.1111	DD11.0111.1111.03	DD11.0111.9110	DD11.0113.1110	DD11.0113.1111
DD11.0113.9110	DD11.0114.1110	DD11.0114.1111	DD11.0121.1110	DD11.0121.1110.01
DD11.0121.1110.02	DD11.0121.1111	DD11.0121.9110	DD11.0122.9110	DD11.0123.1110
DD11.0123.1111	DD11.0123.9110	DD11.0124.1110	DD11.0124.1111	DD11.0124.9110
DD11.0131.1111				

2 Type of change

Change of rating marks on the product.

3 Detailed description of change

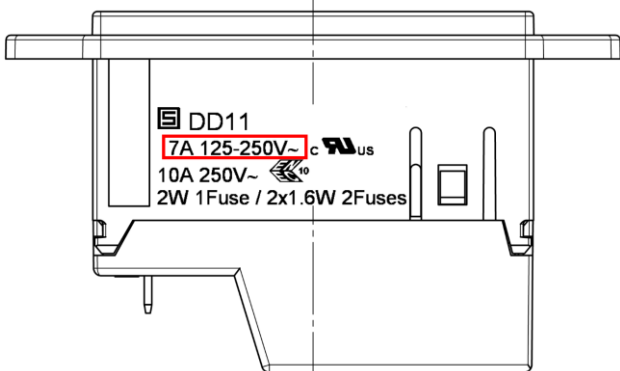
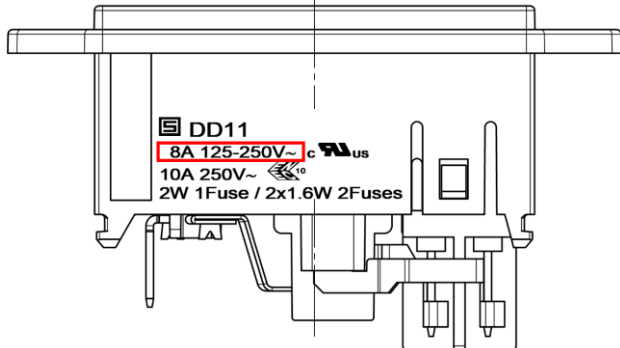
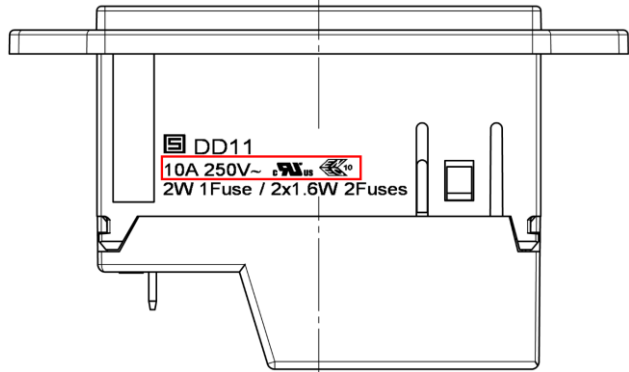
Old product rating	New product rating
<p>With cover</p>  <p>Without cover</p> 	<p>With or without cover</p> 

4 Reason of change

Standards update according to the new UL/CSA 60320-1.

5 Release date

The change will be rolled out starting ww 52/2018 (Date code 1852 or higher on packaging label) and lasts approx. 6 months depending on the variant. This change has no effect on the validity of the approval certificates.

Product Change Notification					DD11 Power entry module		
owner	creation date	release date	released by	change order no	rev	page	D10-032-542
sariogar	05.12.2018	06.12.2018	limachcl	2016776	A	1 of 2	

6 Impact of change and recommended action

Form	Yes	Change of rating marks
Fit	No	No change for dimension
Function	No	No change in function
Manufacturing	No	No change for manufacturing site
Label	No	No change on label
Packaging	No	No change in packaging

7 Reference Documents / Attachments

Kind of document	Remarks
DD11 data sheet	

Product Change Notification					DD11 Power entry module		
owner	creation date	release date	released by	change order no	rev	page	D10-032-542
sariogar	05.12.2018	06.12.2018	limachcl	2016776	A	2 of 2	