

PC BOARD CONNECTORS

740 SERIES

■ FEATURES

- Various types of headers are available: one side shrouded, both sides shrouded, with simplified latch, and box type.
- The connector having a simplified latch prevents the connector from working loose because of vibration.
- The mini header has a clip to prevent incorrect insertion.
- A 740 series connector with a power terminal (2 in 1) for SCSI/IDE interface unit connections is also available.

■ SPECIFICATIONS

1. Standard type

Item	Specification
Operating temperature range	-55°C to +105°C
Current rating	DC 1 A
Voltage rating	AC 250 V
Contact resistance	15 mΩ max. (DC 6 V, 0.1 A)
Insulation resistance	1000 MΩ min. (DC 500 V)
Dielectric strength	AC 500 V for 1 minute
Insertion force	3.5 kg max. (10 pins), 10.5 kg max. (30 pins)
Withdrawal force	0.25 kg min. (10 pins), 1.0 kg min. (30 pins)
Applicable wire	Flat cable: 1.27 mm (0.050 in.) pitch AWG #28 (stranded) or AWG #30 (solid)
Applicable PC board (standard)	1.6 mm

2. Power connector integrated type

Item	Specification
Operating temperature range	-55°C to +105°C
Current rating	DC 1 A (signal pin) DC 5 A (power pin)
Voltage rating	AC 250 V
Contact resistance	15 mΩ max. (signal pin, DC 6 V, 0.1 A) 10 mΩ max. (power pin, DC 6 V, 0.3 A)
Insulation resistance	1000 MΩ min. (DC 500 V)
Dielectric strength	AC 500 V for 1 minute (signal pin) AC 1000 V for 1 minute (power pin)
Insertion force	50-contact signal pin: 17.5 kg max. 40-contact signal pin: 14.0 kg max. Power pin (reference value): 8.8 kg max.
Withdrawal force	50-contact signal pin: 2.0 kg max. 40-contact signal pin: 1.5 kg max. Power pin (reference value): 0.8 kg max.
Applicable PC board (standard)	1.6 mm (0.062 in.) (through hole type)

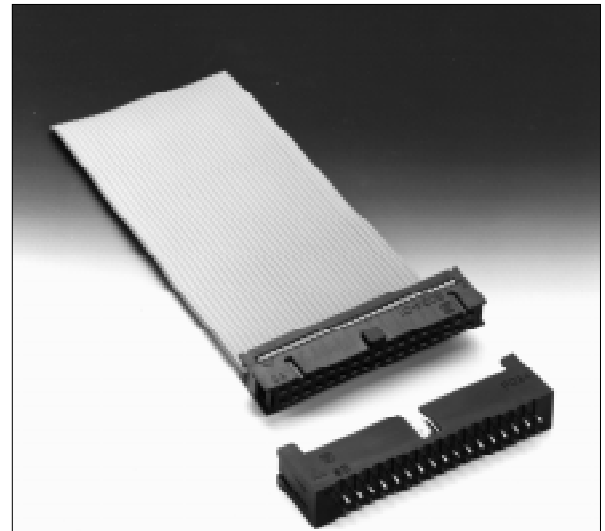

■ MATERIALS

1. Standard type

Item	Materials	
Insulating material	Polyester (UL94V-0)	
Conductor	Copper alloy	
Plating	Contact	Gold
	Terminal	Palladium

2. Power connector integrated type

Item	Materials	
Insulating material	Through hole type: Polyester (UL94V-0) SMT type: PPS (UL94V-0)	
Conductor	Copper alloy	
Plating	Signal pin contact	Gold
	Signal pin tail	Palladium
	Power pin	Solder

■ APPLICATION EXAMPLE

1. Standard type

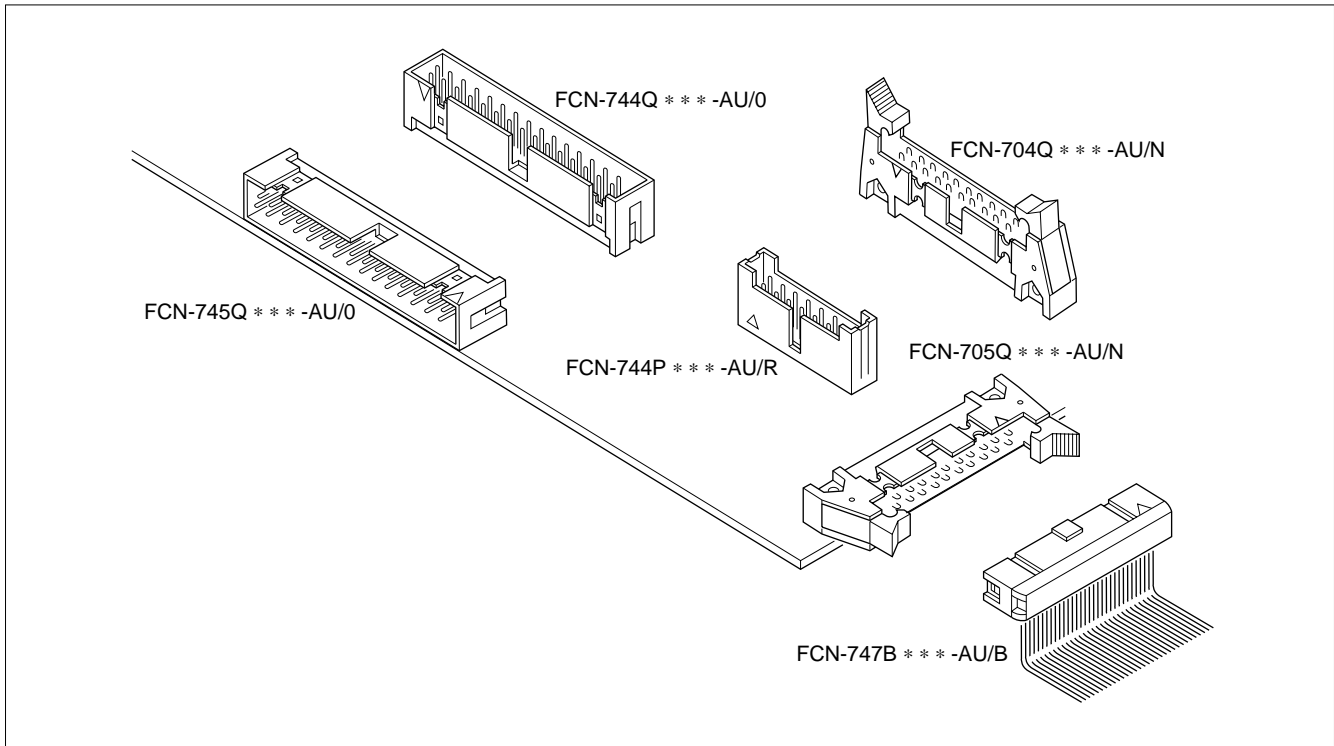

2. Power connector integrated type

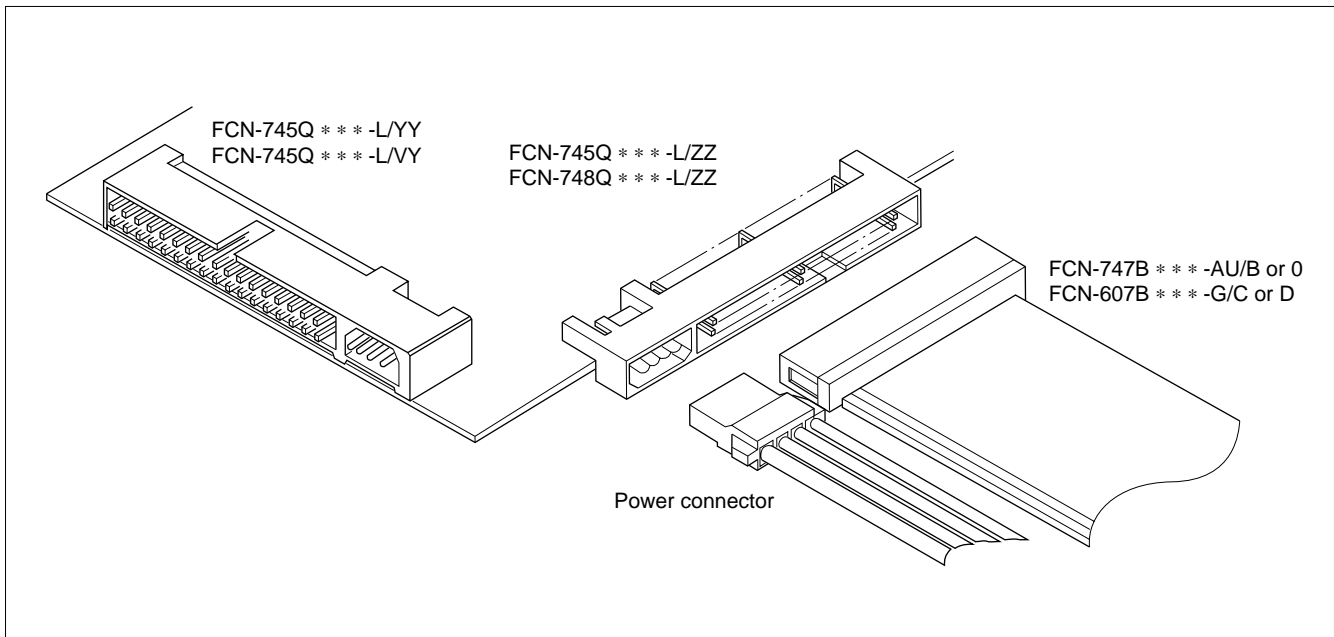

STRAIGHT PLUG (WITH SIMPLIFIED LATCH)

■ DIMENSIONS

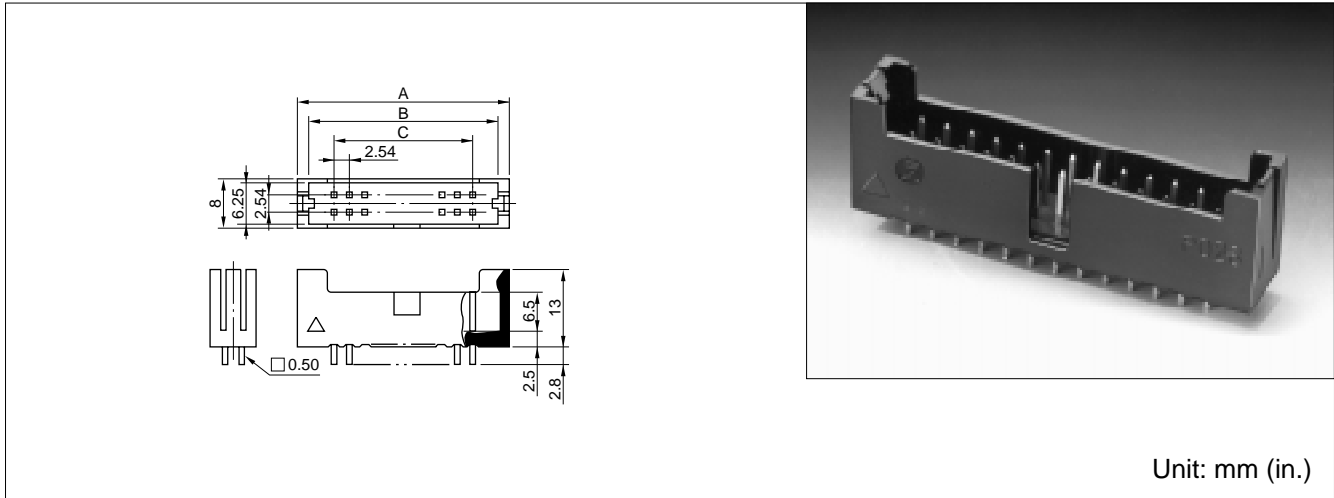

■ MOUNTING HOLE LAYOUT

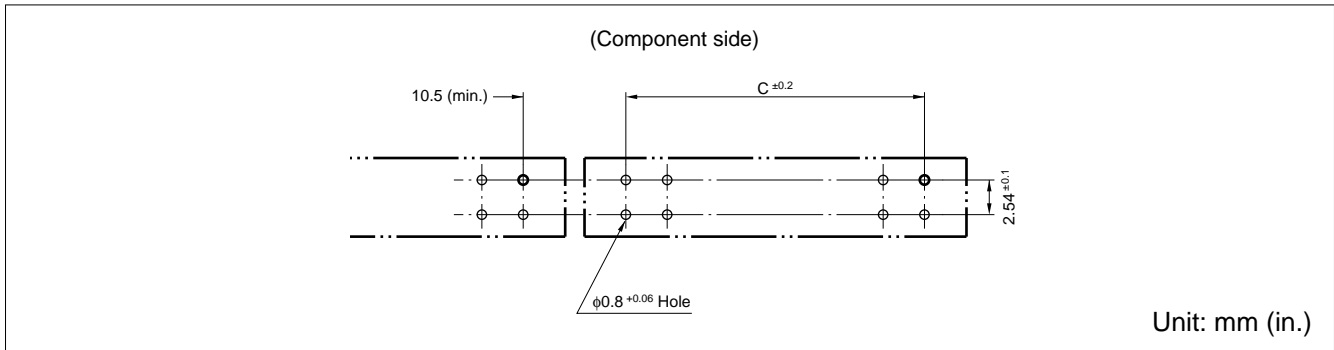

■ PART NUMBERS AND DIMENSIONS

Number of contacts	Part number	Mini header		
		Dimensions: mm (in.)		
		A	B	C
10	FCN-744P010-AU/R	20.12	17.72	10.16
14	FCN-744P014-AU/R	25.20	22.80	15.24
16	FCN-744P016-AU/R	27.74	25.34	17.78
20	FCN-744P020-AU/R	32.82	30.42	22.86
24	FCN-744P024-AU/R	37.90	35.50	27.94
26	FCN-744P026-AU/R	40.44	38.04	30.48
30	FCN-744P030-AU/R	45.52	43.12	35.56
34	FCN-744P034-AU/R	50.60	48.20	40.64

Fujitsu Components International Headquarter Offices

Japan

Fujitsu Component Limited
Gotanda-Chuo Building
3-5, Higashigotanda 2-chome, Shinagawa-ku
Tokyo 141, Japan
Tel: (81-3) 5449-7010
Fax: (81-3) 5449-2626
Email: promothq@ft.ed.fujitsu.com
Web: www.fcl.fujitsu.com

North and South America

Fujitsu Components America, Inc.
250 E. Caribbean Drive
Sunnyvale, CA 94089 U.S.A.
Tel: (1-408) 745-4900
Fax: (1-408) 745-4970
Email: marcom@fcai.fujitsu.com
Web: www.fcai.fujitsu.com

Europe

Fujitsu Components Europe B.V.
Diamantlaan 25
2132 WV Hoofddorp
Netherlands
Tel: (31-23) 5560910
Fax: (31-23) 5560950
Email: info@fceu.fujitsu.com
Web: www.fceu.fujitsu.com

Asia Pacific

Fujitsu Components Asia Ltd.
102E Pasir Panjang Road
#04-01 Citilink Warehouse Complex
Singapore 118529
Tel: (65) 6375-8560
Fax: (65) 6273-3021
Email: fcal@fcal.fujitsu.com
www.fcal.fujitsu.com

© 2002 Fujitsu Components America, Inc. All company and product names are trademarks or registered trademarks of their respective owners. Rev. 10/2002