



Flight II 90 (DC Fan)

COMAIR ROTRON PART NUMBER: **031168**
 COMAIR ROTRON MODEL NUMBER: **FN12B3**



MOTOR	
Rated Voltage:	12
Operating Voltage Range:	6 - 14
Running Current: 50Hz 60Hz (amps)	
Locked Rotor Current: (amps)	0.5
Rated Power: 50Hz 60Hz (watts)	
Nominal Speed: 50Hz 60Hz (rpm)	

MECHANICAL	
Dimensions:	92mm x 25mm (3.62in x 1.00in)
Bearing Type:	Ball
Motor Base:	Polyphenylene Oxide (PPO), UL94V-0, Black
Propeller:	Polybutylene Terephthalate (PBT), UL94V-0, Black

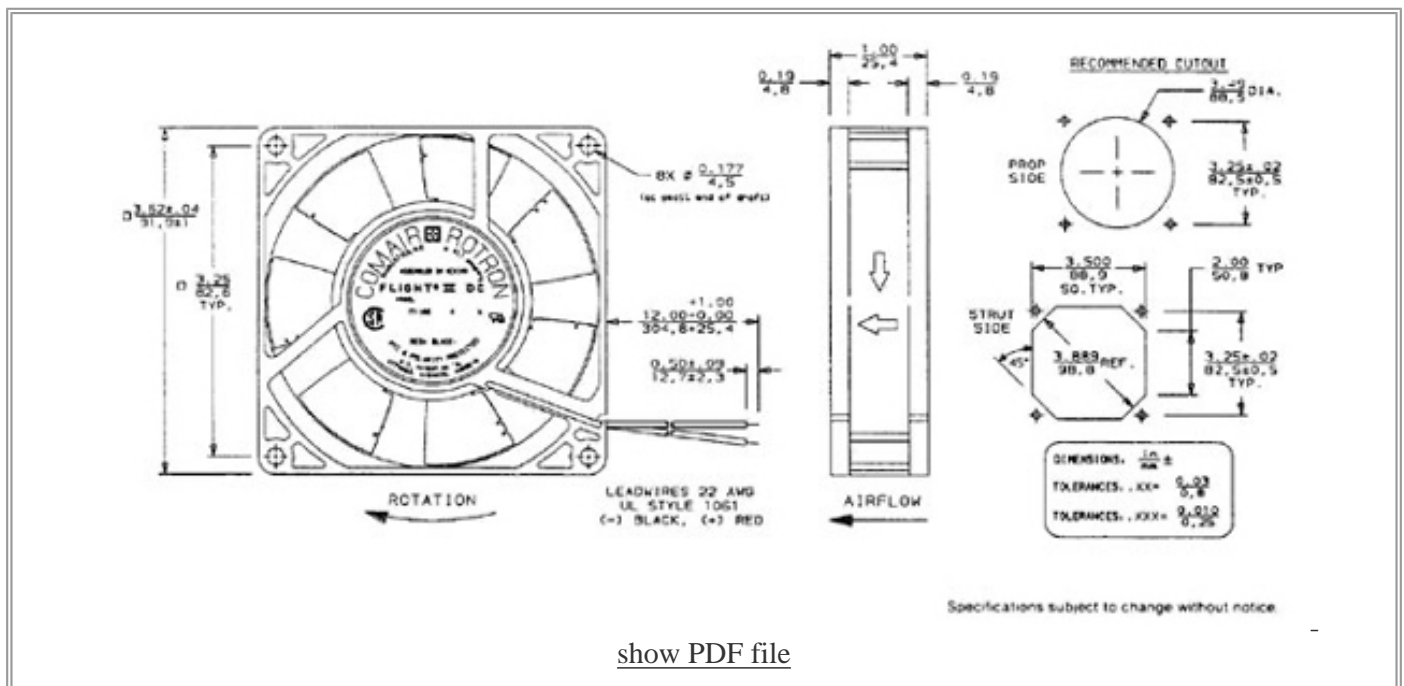

[show PDF file](#)

NOTES

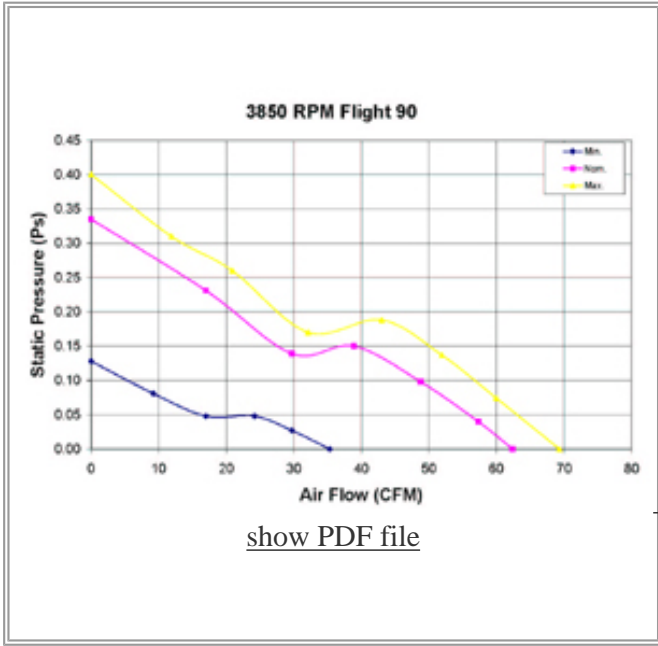

PERFORMANCE CHARACTERISTICS	
Air Flow: (CFM)	45
Static Pressure:	.182

TERMINATION	
Leadwires:	12" Leadwires

SAFETY	
	
	
	

All product names are used under license and are trademarks or registered trademarks of Comair Rotron, Inc.

[New Search](#)

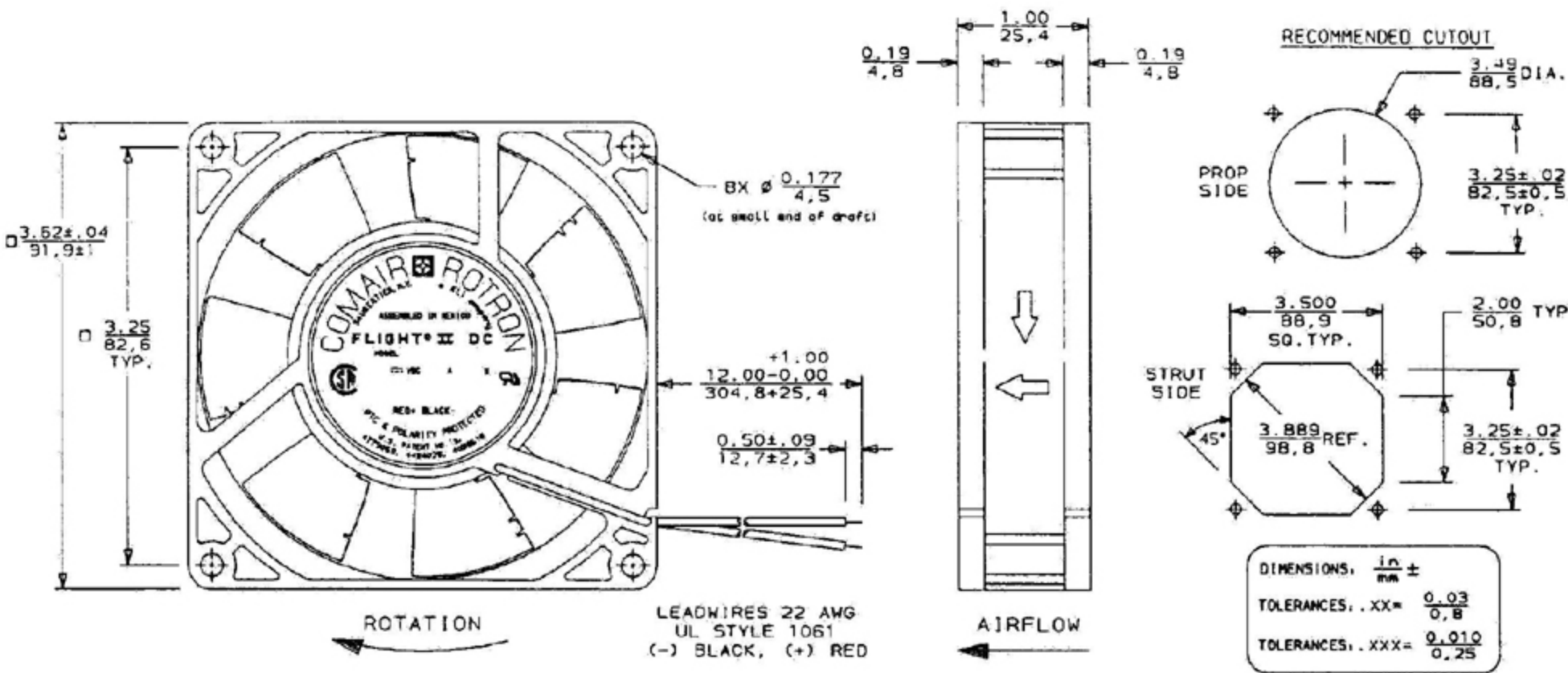

Specifications subject to change without notice.