

Optical Liquid Level Sensors D102 Series

DURAKOOL

Features:

- M12 x 1 Thread
- Low Power
- Low Cost
- Compact size
- Wide range of commercial and industrial applications
- Detect almost any liquid type - oil or water based



	Standard Temperature	High Temperature
Housing Material	Polysulfone	
Housing / Mounting	M12	
Output Type / Logic	Push / Pull - Digital High in Air	
Output Current (sink & source)	Up to 100mA (Iout)	
Pressure°	7 bar / 101 psi max.	
Supply Current	2.5mA max. (Vs = 15.4 VDC)	
Supply Voltage	4.5 - 15.4 VDC	
Temperature - Operating (Storage)	-25°C to +80°C (-30°C to +85°)	
Thread	M12 x 1 x 8g with hex nut and washer	
Tightening Torque	1.5 Nm / 13.26 in-lbs maximum	
Sensor Termination	24AWG - 250mm PTFE wires - 8mm tinned	

The minimum load impedance should not exceed Vs/max output current. Shorting the output to VS or OV will result in irreparable damage to the sensor. Before use, check the fluid you wish to use is compatible with Polysulfone.

Order Codes:

- D102000 Standard Temperature Range
D102100 Extended Temperature Range

Drawing dimensions in millimetres

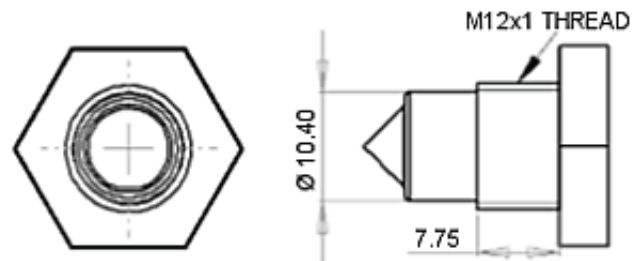
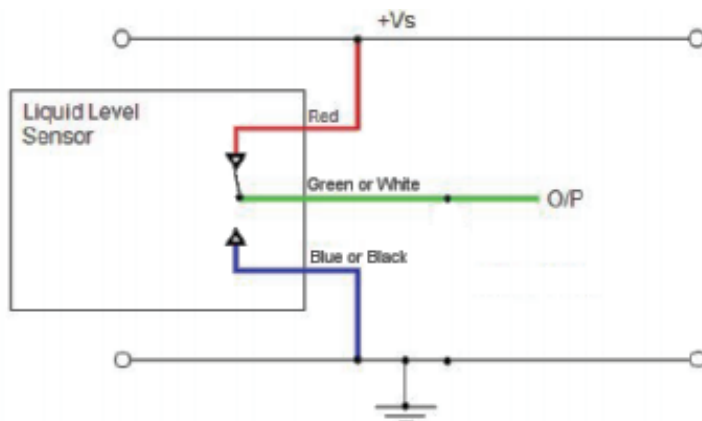

Contact factory for custom terminations and other lead lengths available to special order.



© American Electronic Components Inc 2008

American Electronic Components Inc.,
1101 Lafayette Street, Elkhart, Indiana, USA
Tel: +1-574-295-6330 Fax: +1-574-293-8013
Email: sales@aecensors.com
<http://www.aecensors.com>