

MAX20336

Ultra-Small, Low- R_{ON} , Beyond-the-Rails™ DPST Analog Switches

General Description

The MAX20336 ultra-small, low-on-resistance (R_{ON}) double-pole/single throw (DPST) analog switches feature Beyond-the-Rails™ capability that allows signals from -5.5V to +5.5V to pass without distortion, even when the power supply is below the signal range. The low on-resistance (0.19 Ω) also makes the devices ideal for low-distortion switching applications, such as audio or video.

The MAX20336 is fully specified to operate from a single +1.6V to +5.5V power supply. Because of the low supply current requirement, V_{CCEN} can be provided by a GPIO. When power is not applied, the switches go to a high-impedance mode and all analog signal ports can withstand signals from -5.5V to +5.5V.

The MAX20336 is available in a 1.308mm x 0.828mm, 0.4mm pitch, 6-bump wafer-level package (WLP) and operates over the -40°C to +85°C extended temperature range.

Applications

- Cell phone
- Tablet
- Portable Audio/Video Equipment
- Portable Navigation Devices

Benefits and Features

- Distortion-Free Beyond-the-Rails Signaling
 - Negative Voltage Audio and Video Signal Capable
 - -5.5V to +5.5V Analog Signal Range Independent of V_{CCEN}
 - On-Resistance 0.19 Ω (Typ)
 - +1.6V to +5.5V Single-Supply Range
 - Total Harmonic Distortion Plus Noise -114dB (Typ)
 - On-Resistance Flatness 0.0001 Ω (Typ)
- Low Supply Current 65 μ A (Typ) at 1.6V
 - Can be Powered by GPIO
 - High-Impedance Mode When V_{CCEN} Not Applied
- ESD Protection on COM_, NO_
 - \pm 30kV Human Body Model
 - \pm 7kV IEC 61000-4-2 Air Gap
 - \pm 8kV IEC 61000-4-2 Contact
- Design Flexibility
 - 6-Bump WLP (1.308mm x 0.828mm)
 - -40°C to +85°C Operating Temperature Range

[Ordering Information](#) appears at end of data sheet.

Absolute Maximum Ratings

V_{CCEN} to GND	-0.3V to +6V	Continuous Power Dissipation ($T_A = +70^\circ\text{C}$)	
NO_-, COM_- to GND	-6V to +6V	WLP (derate 10.51mW/ $^\circ\text{C}$ above $+70^\circ\text{C}$).....	840.8mW
Continuous Current NO_-, COM_-	$\pm 500\text{mA}$	Operating Temperature Range	-40°C to $+85^\circ\text{C}$
Peak Current NO_-, COM_-		Junction Temperature	$+150^\circ\text{C}$
(50% duty cycle, 10ms pulse)	$\pm 850\text{mA}$	Storage Temperature Range	-65°C to $+150^\circ\text{C}$
		Soldering Temperature (reflow)	$+260^\circ\text{C}$

Stresses beyond those listed under "Absolute Maximum Ratings" may cause permanent damage to the device. These are stress ratings only, and functional operation of the device at these or any other conditions beyond those indicated in the operational sections of the specifications is not implied. Exposure to absolute maximum rating conditions for extended periods may affect device reliability.

Package Information

PACKAGE TYPE: 6 BUMP WLP	
Package Code	N60K1+1
Outline Number	21-100308
Land Pattern Number	Refer to Application Note 1891
THERMAL RESISTANCE, FOUR-LAYER BOARD:	
Junction to Ambient (θ_{JA})	95.15 $^\circ\text{C}/\text{W}$

For the latest package outline information and land patterns (footprints), go to www.maximintegrated.com/packages. Note that a "+", "#", or "-" in the package code indicates RoHS status only. Package drawings may show a different suffix character, but the drawing pertains to the package regardless of RoHS status.

Package thermal resistances were obtained using the method described in JEDEC specification JESD51-7, using a four-layer board. For detailed information on package thermal considerations, refer to www.maximintegrated.com/thermal-tutorial.

Electrical Characteristics

($V_{CCEN} = +1.6\text{V}$ to $+5.5\text{V}$, $T_A = -40^\circ\text{C}$ to $+85^\circ\text{C}$, unless otherwise noted. Typical values are at $V_{CCEN} = +2.5\text{V}$, $T_A = +25^\circ\text{C}$, unless otherwise noted.) (Note 1)

PARAMETER	SYMBOL	CONDITIONS	MIN	TYP	MAX	UNITS
POWER SUPPLY						
Power-Supply Range	V_{CCEN}		1.6		5.5	V
Power-Supply Rejection Ratio	PSRR	$R_{COM_-} = 32\Omega$, $f = 20\text{kHz}$		90		dB
Supply Current	I_{CC}	$V_{CCEN} = +1.6\text{V}$		65	115	μA
		$V_{CCEN} = +4.2\text{V}$		100	190	
ANALOG SWITCH						
Analog Signal Range	V_{NO_-}, V_{COM_-}		-5.5		+5.5	V
On-Resistance	R_{ON}	$V_{CCEN} = 2.5\text{V}$, $V_{COM_-} = 0\text{V}$, $I_{COM_-} = 100\text{mA}$ (Note 2)		0.19	0.33	Ω
		$V_{CCEN} = 1.8\text{V}$, $V_{COM_-} = 0\text{V}$, $I_{COM_-} = 100\text{mA}$ (Note 2)		0.225	0.40	
On-Resistance Match Between Channels	ΔR_{ON}	$V_{CCEN} = 2.5\text{V}$, $I_{COM_-} = 100\text{mA}$, between two channels	-0.05	0.003	0.05	Ω
On-Resistance Flatness	R_{FLAT}	$V_{CCEN} = 2.5\text{V}$, $I_{COM_-} = 100\text{mA}$, $V_{COM_-} = -5.5\text{V}$ to $+5.5\text{V}$ (Note 3, Note 4)		0.0001	0.01	Ω

Electrical Characteristics (continued)

($V_{CCEN} = +1.6V$ to $+5.5V$, $T_A = -40^\circ C$ to $+85^\circ C$, unless otherwise noted. Typical values are at $V_{CCEN} = +2.5V$, $T_A = +25^\circ C$, unless otherwise noted.) (Note 1)

PARAMETER	SYMBOL	CONDITIONS	MIN	TYP	MAX	UNITS
NO ₋ , COM Off-Leakage Current	$I_{NO_ (OFF)}$, $I_{COM_ (OFF)}$	$V_{CCEN} = 0V$, $V_{NO_} = -5.5V$ or $+5.5V$, $V_{COM_} = -5.5V$, $+5.5V$, unconnected	-100		+100	nA
COM On-Leakage Current	$I_{COM_ (ON)}$	$V_{CCEN} = 2.5V$, switch closed, $V_{COM_} = V_{NO_} = -5.5V$ or $+5.5V$	-50		+50	nA
DYNAMIC TIMING						
Turn-On Time	t_{ON}	V_{CCEN} from 0V to 2.5V, $V_{NO_} = 5.5V$, $R_L = 50\Omega$, (Figure 1)		1.7		ms
Turn-Off Time	t_{OFF}	V_{CCEN} from 2.5V to 0V, $V_{NO_} = 5.5V$, $R_L = 50\Omega$, (Figure 1)		13.5		ms
AUDIO PERFORMANCE						
Total Harmonic Distortion Plus Noise	THD + N	$f = 20Hz$ to $20kHz$, $V_{COM_} = 1V_{P-P}$, $R_S = 20\Omega$, $R_L = 32\Omega$, DC bias = 0		-109		dB
		$f = 20Hz$ to $20kHz$, $V_{COM_} = 1V_{P-P}$, $R_S = 20\Omega$, $R_L = 600\Omega$, DC bias = 0		-109		
		$f = 20Hz$ to $20kHz$, $V_{COM_} = 1V_{RMS}$, $R_S = 20\Omega$, $R_L = 32\Omega$, DC bias = 0		-114		
		$f = 20Hz$ to $20kHz$, $V_{COM_} = 1V_{RMS}$, $R_S = 20\Omega$, $R_L = 600\Omega$, DC bias = 0		-114		
Off-Isolation	V_{ISO}	$R_S = R_L = 50\Omega$; $V_{COM_} = 0.5V_{P-P}$, $f = 100kHz$, $V_{CCEN} = 0V$, DC bias = $0.25V$, (Figure 2)		-55		dB
Crosstalk	V_{CT}	$R_S = R_L = 50\Omega$, $V_{COM_} = 0.5V_{P-P}$, $f = 100kHz$ (Figure 2)		-85		dB
-3dB Bandwidth	BW	$R_S = R_L = 50\Omega$		270		MHz
NO ₋ Off-Capacitance	$C_{NO_ (OFF)}$	$V_{NO_} = 0.5V_{P-P}$, $f = 1MHz$, COM ₋ unconnected		14		pF
COM ₋ On-Capacitance	$C_{COM_ (ON)}$	$V_{NO_} = 0.5V_{P-P}$, $f = 1MHz$		11		pF
THERMAL PROTECTION						
Thermal Shutdown	T_{SHDN}			150		$^\circ C$
Thermal Hysteresis	T_{HYST}			25		$^\circ C$
ESD PROTECTION						
COM ₋ , NO ₋		HBM		± 30		kV
		IEC61000-4-2 Air-Gap Discharge		± 7		
		IEC61000-4-2 Contact Discharge		± 8		
All other pins		HBM		± 2		kV

Note 1: All specifications are 100% production tested at $T_A = +25^\circ C$, unless otherwise noted. Specifications are over $T_A = -40^\circ C$ to $+85^\circ C$ and are guaranteed by design.

Note 2: The same limits apply for $V_{COM_} = -5.5V$ to $+5.5V$ and are guaranteed by design.

Note 3: Flatness is defined as the difference between the maximum and minimum value of on-resistance, as measured over specified analog signal ranges.

Note 4: Guaranteed by design; not production tested.

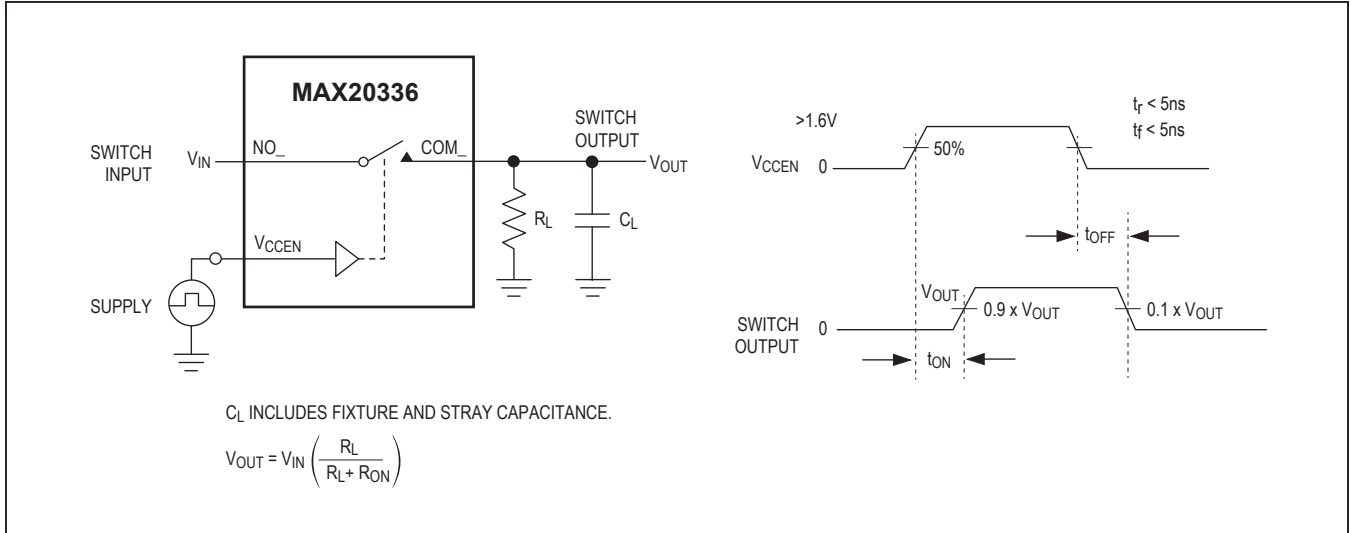

Figure 1. Switching Time

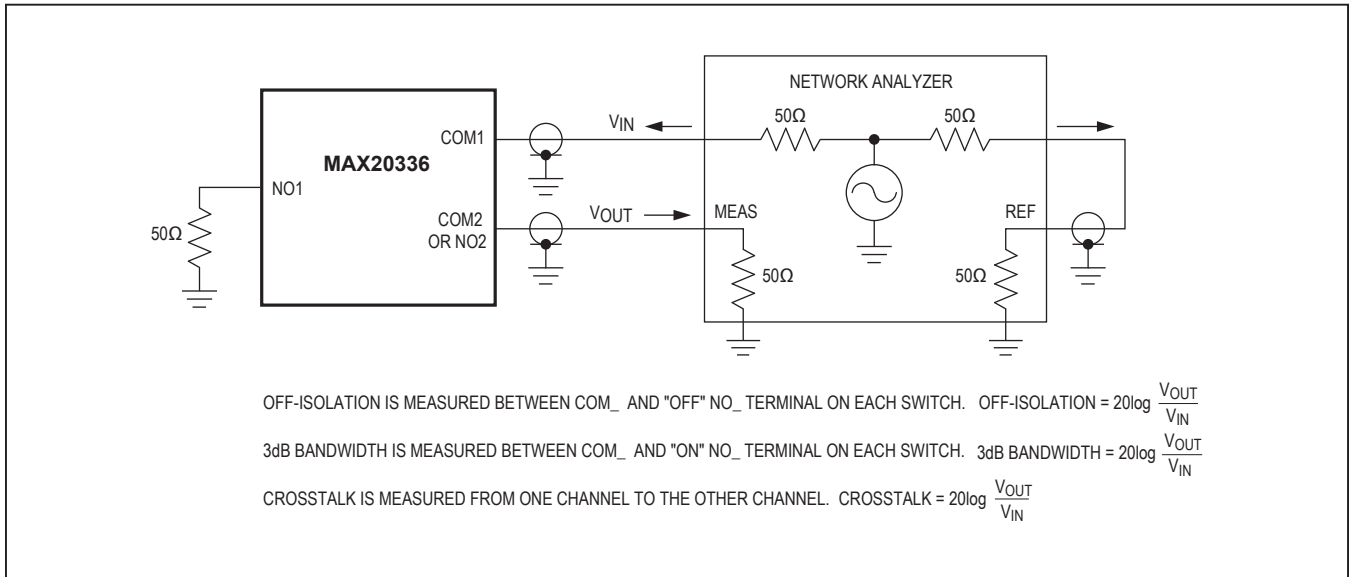
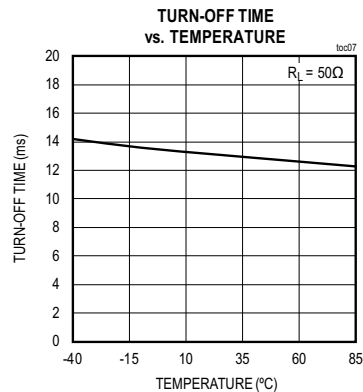
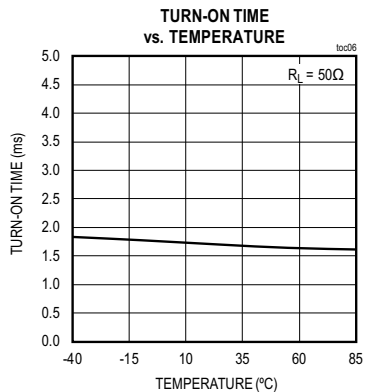
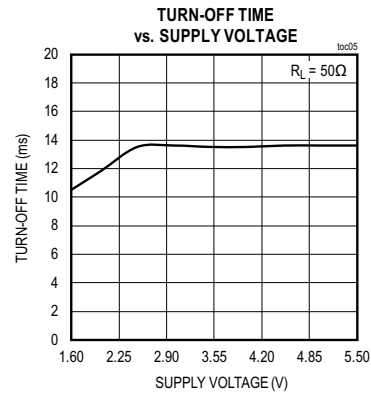
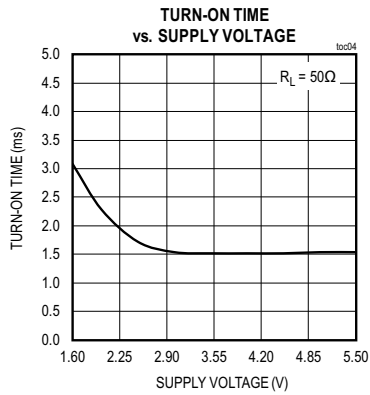
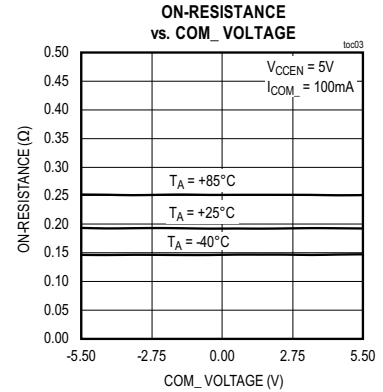
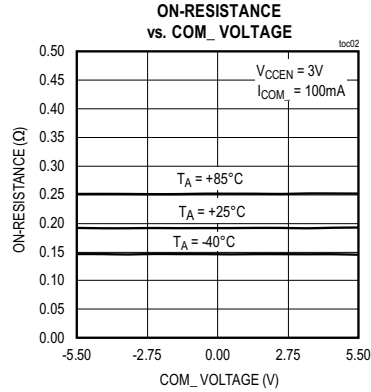
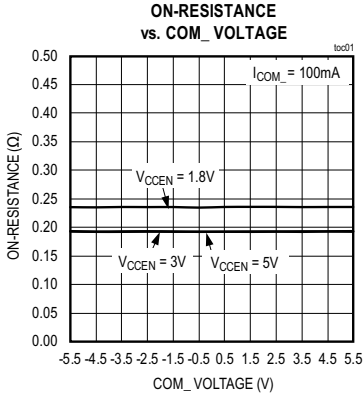

Figure 2. 3dB Bandwidth, Off-Isolation, and Crosstalk

Typical Operating Characteristics

($V_{CCEN} = +2.5V$, $T_A = +25^\circ C$, unless otherwise noted.)



Typical Operating Characteristics (continued)

($V_{CCEN} = +2.5V$, $T_A = +25^\circ C$, unless otherwise noted.)

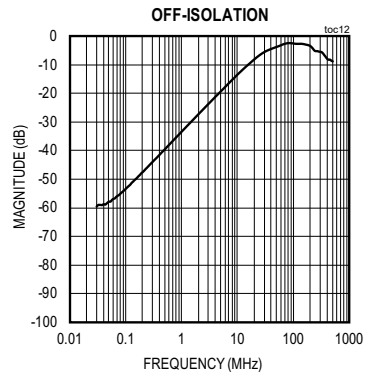
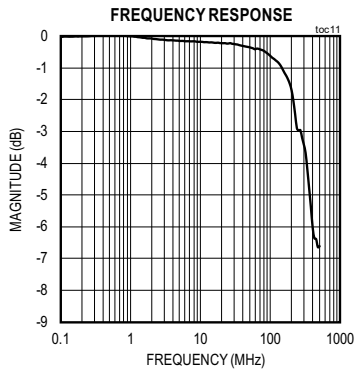
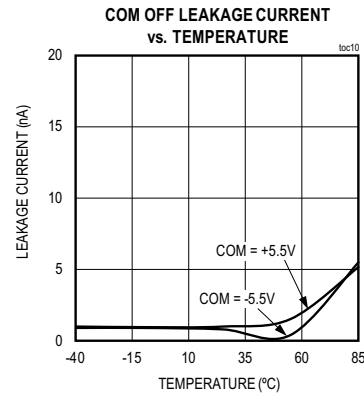
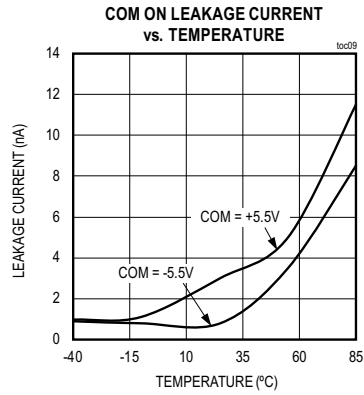
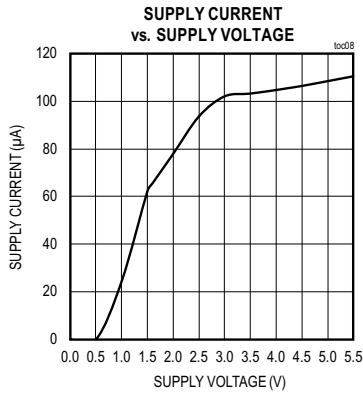

Typical Operating Characteristics (continued)

($V_{CCEN} = +2.5V$, $T_A = +25^\circ C$, unless otherwise noted.)

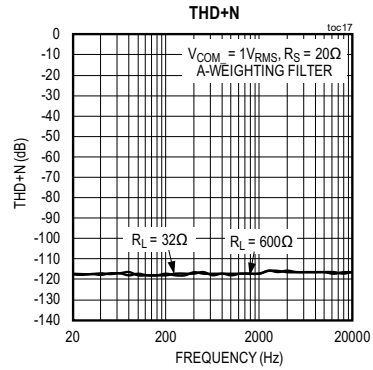
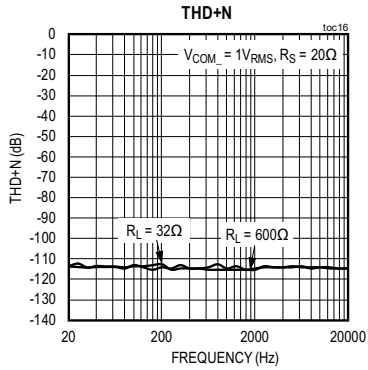
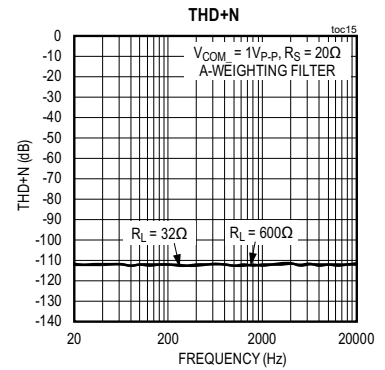
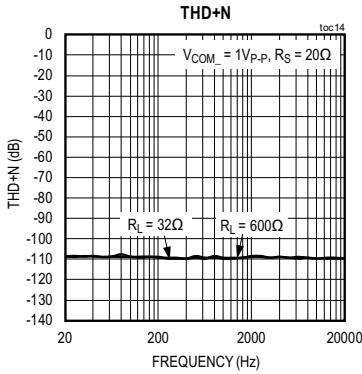
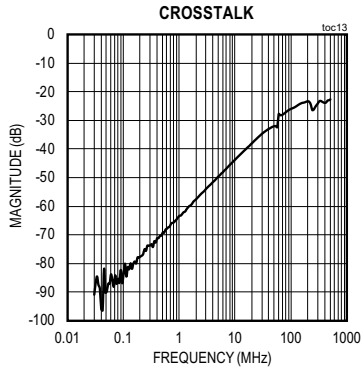

Bump Configuration

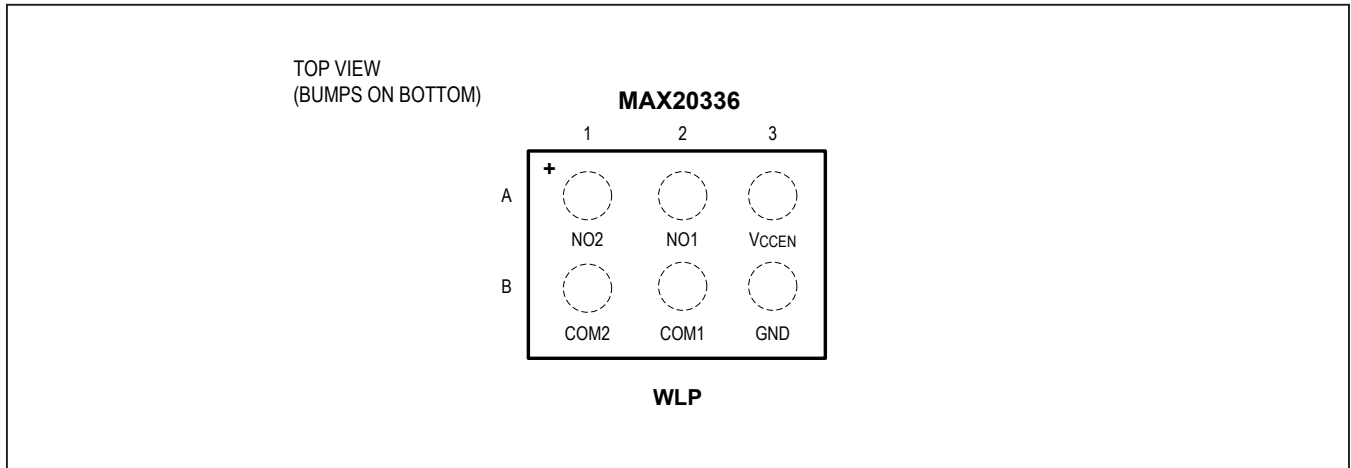

Bump Descriptions

BUMP	NAME	FUNCTION
A1	NO2	Normally Open Terminal for Switch 2
A2	NO1	Normally Open Terminal for Switch 1
A3	VCCEN	Supply Voltage Enable Input. Bypass V_{CCEN} to GND with a 0.1 μ F capacitor as close to the device as possible.
B1	COM2	Common Terminal for Switch 2
B2	COM1	Common Terminal for Switch 1
B3	GND	Ground

Detailed Description

The MAX20336 is an ultra-small, low on-resistance, high ESD-protected DPST switch that operates from a +1.6V to +5.5V supply, and is designed to pass analog signals, such as AC-biased or DC-biased audio and video signals. These switches feature the low on-resistance (R_{ON}) necessary for high-performance switching applications. The Beyond-the-Rails signal capability of the MAX20336 allows signals below ground and above V_{CCEN} to pass without distortion.

Analog Signal Levels

The MAX20336 is bidirectional, allowing NO_{-} and COM_{-} to be configured as either inputs or outputs. The topology of the switches allows the signal to drop below ground without the need of an external negative voltage supply.

Digital Control Input

The MAX20336 combines enable and supply pins. The switches are on when device is powered. Connect V_{CCEN} to GND to turn-off the switches.

Applications Information

Extended ESD Protection

ESD-protection structures are incorporated on all pins to protect against electrostatic discharges up to $\pm 2kV$ (HBM) encountered during handling and assembly. COM_{-} and NO_{-} are further protected against ESD up to $\pm 30kV$ (HBM), $\pm 7kV$ (Air-Gap Discharge), and $\pm 8kV$ (Contact Discharge) without damage. The ESD structures withstand high ESD both in normal operation and when the device is powered down. After an ESD event, the devices continue to function without latchup.

ESD Test Conditions

ESD performance depends on a variety of conditions. Contact Maxim for a reliability report that documents test methodology and test results.

Human Body Model

Figure 3 shows the Human Body Model. Figure 4 shows the current waveform it generates when discharged into a low impedance. This model consists of a 100pF capacitor charged to the ESD voltage of interest that is then discharged into the device through a 1.5k Ω resistor.

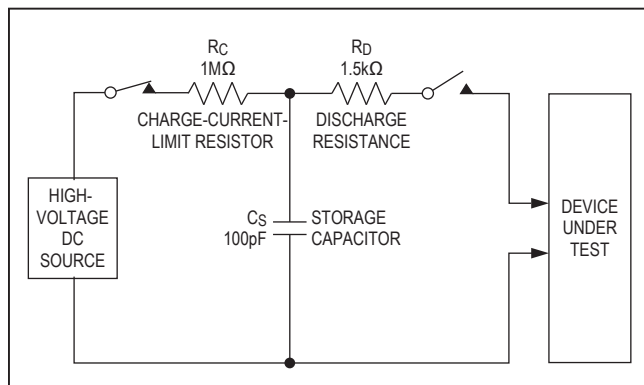

Figure 3. Human Body ESD Test Model

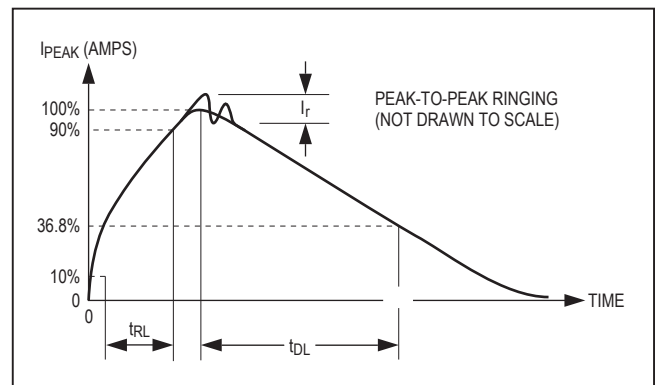

Figure 4. Human Body Current Waveform

IEC 61000-4-2

The IEC 61000-4-2 standard covers ESD testing and performance of finished equipment. It does not specifically refer to integrated circuits. The major difference between tests done using the HBM and IEC 61000-4-2 is higher peak current in IEC 61000-4-2,

because series resistance is lower in the IEC 61000-4-2 model. Hence, the ESD withstand voltage measured to IEC 61000-4-2 is generally lower than that measured using the HBM. Figure 5 shows the IEC 61000-4-2 model and Figure 6 shows the current waveform for the $\pm 8\text{kV}$, IEC 61000-4-2, Level 4, ESD Contact-Discharge Method.

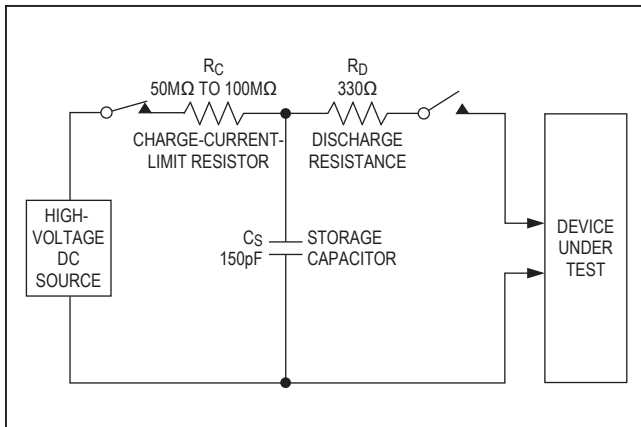

Figure 5. IEC 61000-4-2 ESD Test Model

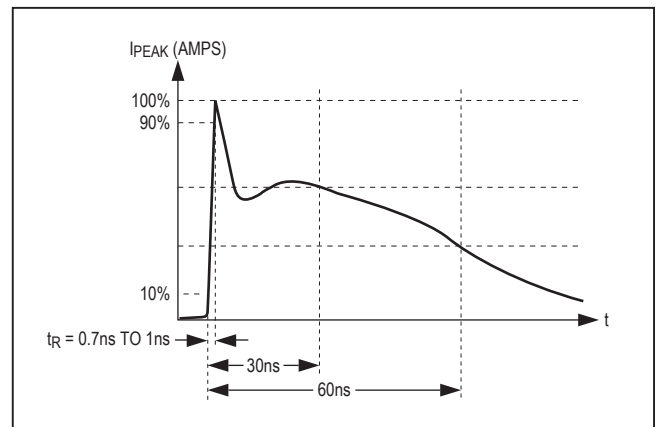
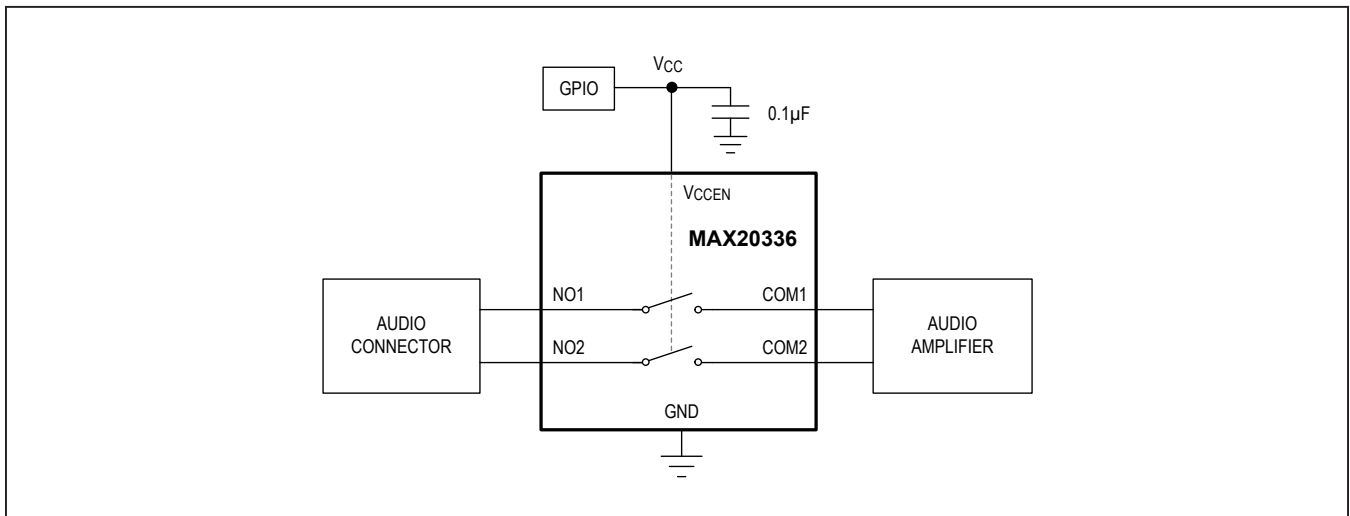

Figure 6. IEC 61000-4-2 ESD Generator Current Waveform

Typical Application Circuit



MAX20336

Ultra-Small, Low- R_{ON} ,
Beyond-the-Rails™ DPST Analog Switches

Ordering Information

PART NUMBER	PIN-PACKAGE	[TOP MARKING]	PACKAGE CODE	PACKAGE OUTLINE DRAWING
MAX20336ENT+	6 WLP	AM	N60K1+1	21-100308
MAX20336ENT+T	6 WLP	AM	N60K1+1	21-100308
MAX20336AEFT+*	6 FC2QFN	AA	F61A1F+1	21-100313
MAX20336AEFT+T*	6 FC2QFN	AA	F61A1F+1	21-100313

* Denotes a future product

+ Denotes a lead(Pb)-free/RoHS-compliant package.

T Denotes tape-and-reel.

Revision History

REVISION NUMBER	REVISION DATE	DESCRIPTION	PAGES CHANGED
0	2/19	Initial release	—

For pricing, delivery, and ordering information, please visit Maxim Integrated's online storefront at <https://www.maximintegrated.com/en/storefront/storefront.html>.

Maxim Integrated cannot assume responsibility for use of any circuitry other than circuitry entirely embodied in a Maxim Integrated product. No circuit patent licenses are implied. Maxim Integrated reserves the right to change the circuitry and specifications without notice at any time. The parametric values (min and max limits) shown in the Electrical Characteristics table are guaranteed. Other parametric values quoted in this data sheet are provided for guidance.