

NO: FJOS1902062

CUSTOMER PN _____

SPECIFICATION FOR APPROVAL

MEGA PART NO MJSW1203000N

MEGA MODEL NO FJ-SW1203000N (528)

DESCRIPTION 12V 3000mA

DATE 2019-03-10



MANUFACTURE			CUSTOMER APPROVAL	
DESIGN	CHECKED	APPROVED		

MEGA Electronics, Inc.

4B Jules Lane
New Brunswick, NJ 08901
Tel: 732-249-2656 Fax: 732-249-7442
Email: sales@megaelectronics.com Website: www.megaelectronics.com

SPECIFICATION FOR APPROVAL

DESCRIPTION 12V 3000mA

DATE 2019-03-10

Revision: 01



TABLE OF CONTENTS

目录

- 1 概述/SCOPE**
- 2 输入特性/INPUT CHARACTERISTICS**
- 3 输出特性/OUTPUT CHARACTERISTICS**
- 4 保护功能/ PROTECTION FUNCTION**
- 5 环境要求/ENVIRONMENTAL REQUIREMENTS**
- 6 机械特性 MECHANICAL CHARACTERISTICS**
- 7 安全标准 /SAFETY**
- 8.EMC 标准/ EMC STANDARD**
- 9 体积/VOLUME**
- 10 重量/WEIGHT**
- 11 外观图/OUTLOOK DRAWING**
- 12 铭牌 /LABEL**
- 13 包装图示/PACKING**
- 14 样品测试报告 / SAMPLES TEST REPORT**

1 概述 /SCOPE

本规格书适合于 [MJSW1203000N](#) 认证型号的开关电源。

The purpose of the document is to specify the functional requirements of [MJSW1203000N](#) switching power supply.

2. 输入特性/ INPUT CHARACTERISTICS:

2.1 输入电压/ Input Voltage

额定输入电压/ Rated Input Voltage: 100-240Vac

可变输入电压/Variable input voltage : 90V—264Vac

2.2 输入电流/Input Current:

当输入额定电压带额定负载时，最大的输入交流电流 [1.5A](#)
[1.5A](#) max when input rated voltage and output rated load.

2.3 输入频率/ Input Frequency

额定频率/Rate Frequency:50/60Hz

调整频率/ Variation Frequency: 47-63Hz

2.4 浪涌电流/In-rush Current:

当输出为额定负载，环境温度为 25℃,输入 240Vac 冷启动时的最大浪涌电流为 60A。
60 A mps Max Cold start at 240Vac input ,with rated load and 25℃ ambient.

2.5 AC 漏电流/ AC leakage Current:

当输入电压 240Vac 时，最大的漏电流为 0.25mA

0.25mA Max .At 240Vac input

3. 输出特性/OUTPUT CHARACTERISTICS:

3.1 额定输出功率/Rated Output Power 36W

3.2 负载特性/调整率 (Combined Load/line Regulation)

电压	最小负载	最大负载	负载调整	空载输出电压
Voltage	Min. Load	Max Load	Load Regulation	Unload output voltage
<u>+12V</u>	0A	<u>3.0A</u>	<u>11.4V-12.6V</u>	<u>11.85V-12.6V</u>

3.3 效率/Efficiency:

VI 级平均工作效率 \geq 87.40%

当输入 115VAC 时, 平均效率 \geq 87.40%。是输出额定负载的 25%,50%,75%,100%4 种情况下平均效率,

115VAC input, the average efficiency \geq 87.40%。 output rated load is 25%,50%,75%,100% 4 situations of average efficiency

当输入 230VAC 时, 平均效率 \geq 87.40%。是输出额定负载的 25%,50%,75%,100%4 种情况下平均效率,

230VAC input, the average efficiency \geq 87.40%。 output rated load is 25%,50%,75%,100% 4 situations of average efficiency

3.4 空载待机功率/Unload standby Power: 0.1W Max

3.5 纹波和噪音/ Ripple And Noise

纹波与噪声: 量测时示波器选用 20MHz 带宽限制,输出端要并联一颗 0.1uF 的陶瓷电容和一颗 47uF 的电解电容。(在额定输入及输出的条件下检测)

Ripple & Noise: Measurement is done by 20MHz bandwidth oscilloscope and the output paralleled a 0.1uF ceramic capacitor and a 47uF electrolysis capacitor. (test under the condition of rated input and rated output)

电压	电流	最大纹波最大噪音
Voltage	current	Ripple And Noise(Max)
<u>+12V</u>	<u>3000mA</u>	120m Vp-p

3.6 启动延迟时间/ Turn On Delay Time:

当输入 100Vac 和输出最大负载时, 最大启动时间为 **5S**

5 second Max .At 100Vac input and output Max. Load

3.7 上升时间/ Rise Time:

当输入 100Vac 和输出最大负载时最大时间为 100ms
100ms Max. At 100Vac input and output Max. Load

3.8 保持时间/ Hold Up Time :

当输入 100Vac 和输出最大负载时，最小保持时间为 5ms
5ms Min.at100Vac input and output Max .Load.

3.9 过冲/ Overshoot:

在电源开启或关闭的时候，最大 10%
10% Max. When power supply on or turn off.

4. 保护功能/ PROTECTION FUNCTION:

4.1 短路电路保护/ Short circuit protection:

电源供给器在短路解除后能正常恢复工作。

The Power Supply will be auto recovered when short circuit faults remove.

4.2 过流保护/ Over current Protection:

过流点限制/Over Current Point Limited:是额定电流的 120-200%(input:110-230Vac)
当过电流时,输出将进入打嗝模式,当过流情况解除后,产品将会自动恢复正常
The output shall hiccup when the over currents applied to the output t rail, and shall
be self-recovery when the fault condition is removed

5. 环境要求/ ENVIRONMENTAL REQUIREMENTS

5.1 工作温度/ Operating Temperature

0°C -- +45°C,满载，正常工作。

0°C to +45°C ,Full Load, Normal Operation.

5.2 储存温度/ Storage temperature

带外壳 :-10°C -- +55°C

With enclosure:-10°C to+55°C

5.3 工作湿度/Relative Humidity:

5%(0°C)~90%(40°C),72 小时, 满载, 正常工作。

5%(0°C)~90%(40°C) 72h Full Load , Normal operating.

5.4 振动/ Vibration:

5.4.1 测试标准: 国际电工电子委员会

Operating: IEC 721-3-3 3M3

5~9Hz,A=1.5mm

加速度 (9~200Hz,Acceleration 5m/s)

5.4.2. 运输 (Transportation) :

IEC 721-3-2 2M2

5~9Hz, A=3.5mm

9~200Hz ,加速度 Acceleration=5 m/s²

200~500Hz ,加速度 acceleration=15 m/s²

5.4.3. 轴向振动/ Axes,10 cycles per axis :

在测试过程中不能出现永久性损坏.

No permanent damage occur during testing.

在电源开启和关闭后, 样机能够恢复到最初条件。

The product has to restore to its original situation after power off/on

6. 机械特性/ MECHANICAL CHARACTERISTICS

6.1 摇摆实验/Cable Flexing Testing

DC 引线吊重 200 克, 摇摆角 60 度, 最少能承受 2000 次, 弯曲速度每分 40 次, 不会出现损伤。

The DC cord shall with weight of 200g,it swings at angle 60 deg ,2000cycle

Time min Bending speed: 40cycle per minute shall to be no breakage to the code

6.2 跌落实验/ Dropping Testing ,

产品从一米高处跌落到木板上无损伤。

The product to be dropped from 1 meter height to a wood floor no breakage。

7. 安全标准 SAFETY STANDARD

7.1 安全:符合标准 IEC60950, EN60950, UL60950, GB4943。

Safety Accord with IEC60950, EN60950, UL60950, GB4943。

注: 相应的 AC 插脚对应相应国家的标准, 如 CE 即对应为 EN60950; 3000Vac

Note: AC pins corresponding corresponding corresponding to national standards, such as the CE that corresponds to EN60950; 3000Vac。

7.2 高压/ DIELECTRIC STRENGTH Hi-Pot

初级对次级/ Primary to secondary, 3000Vac/5mA/5s.

7.3 绝缘阻抗/ Insulation resistance:

初级对次级/ Primary to secondary :10M Ω Min at 500V DC

8. EMC 标准/EMC STANDARD

EMC---EN55032+55020+55024

9. 体积/VOLUME: L \times W \times H

长 103.48mm \times 宽 54.58mm \times 高 40.18mm

10. 重量/ Weight: 183g \pm 20g

12. 铭牌/LABEL:



比例/Scale: 1:1

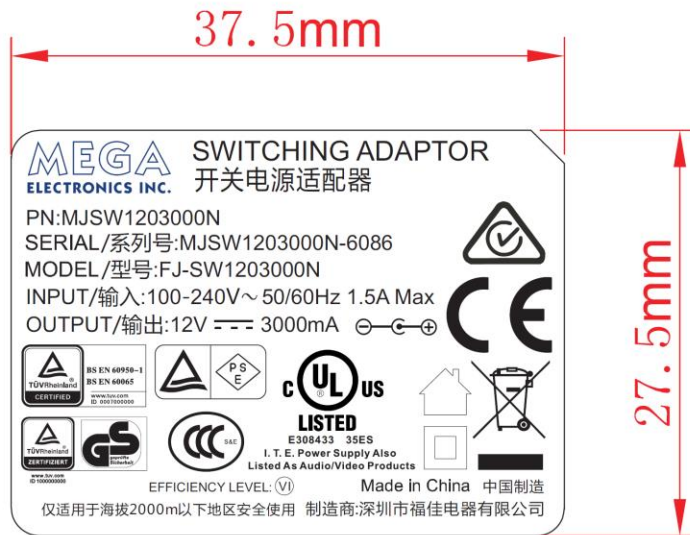

比例/Scale: 2.5:1

注：客户下达订单时请提供该批次产品的“日本进口商名称”，以便体现在电源产品铭牌中。

注：

1. 以上“回”标志，外边长度为内边长度的2倍（请按比例缩放）
2. “CE”标志，最低高度为5MM
3. “WEEE”垃圾桶标志，最低高度为7MM

备注/Note:

1. 材料/Material：PVC 环保/ ROHS.
2. 印刷/Printing：白底黑字/ white ground black character
3. 尺寸/Size:(W)37.5+/-0.2mm(H)27.5+/-0.2mm
4. 厚度/Thickness:0.15mm

XR-312SAA头

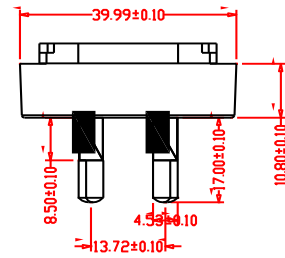
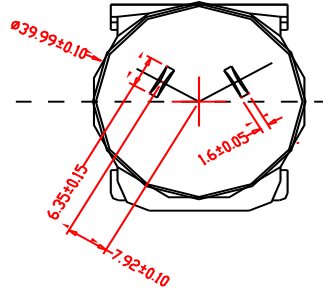

XR-312CE头

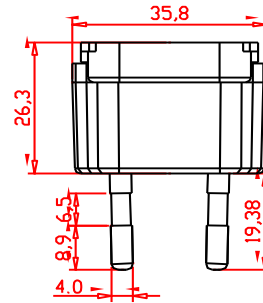
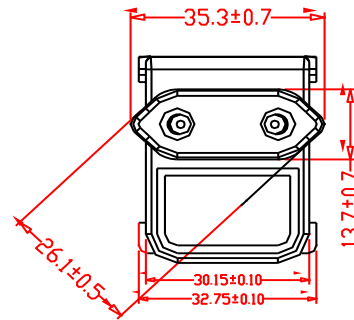

XR-312UL头

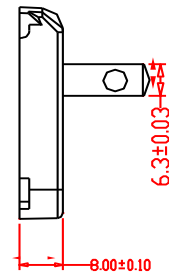
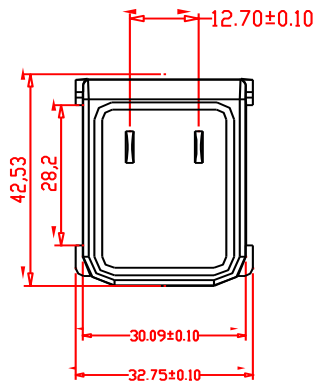

XR-312BS头

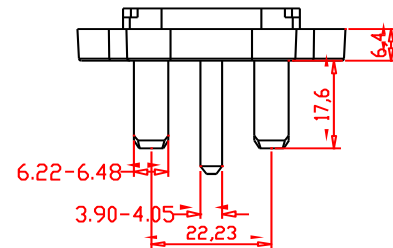
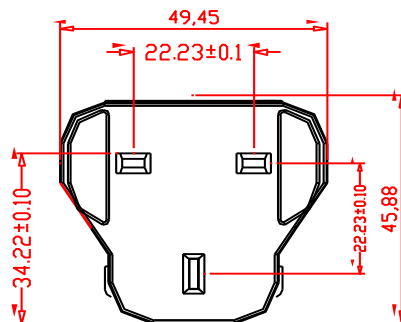

13 包装图示 PACKING

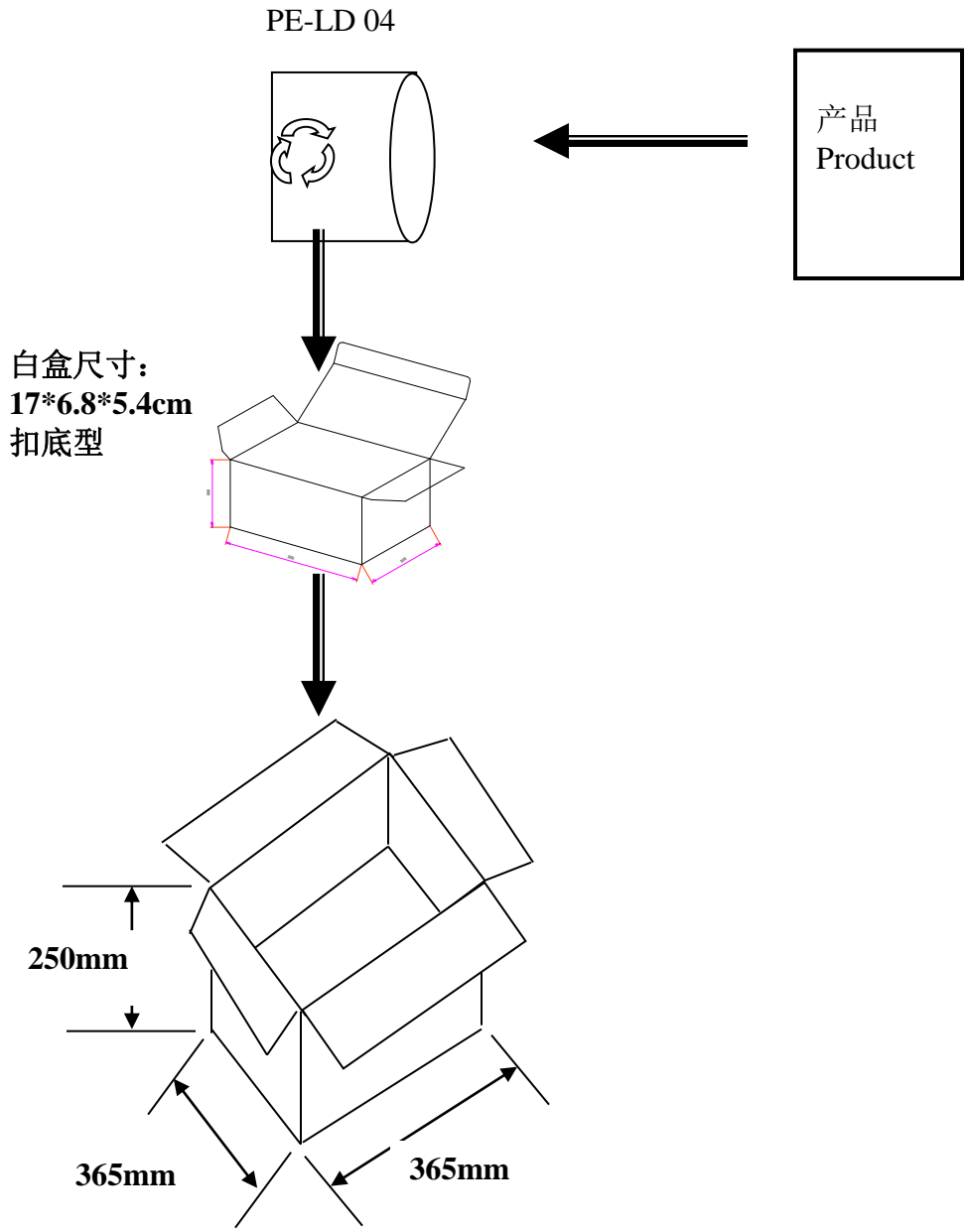

备注/NOTE:

- 1. 每箱装 40 个，分 4 层，材质 K=K
40PCS Per carton, Divided into 4 floor.
Material K=K
- 2. PE 袋尺寸: 205X140MM 带环保标

志。

PE bag size: 205X140MM , With the environmental protection symbol.

14 样品测试报告SAPLES TEST REPORT										
客 户 Customer		F13008ME02		客户编号 Customer No		FJOS1902062		室 温 Ambient temp		25℃
产品型号 Model NO		528活动脚		产品编号 Part No				日 期 Date		2月21日
输入电压/频率 Input volt/Freq		100-240Vac 50/60HZ		输出电压/电流 Output volt/Amp		12V 3A				
测试内容 Test content			1#样机/Sample NO:			2#样机/Sample NO:			判定 judge PASS or NG	
NO	测试项目 Test Item	测试标准 spec	115Vac	230Vac	115Vac	230Vac				
1	空载电压 Unload voltage	11.85-12.6V								
2	空载纹波与噪声UnLoad ripple&noise	≤120mV P-P								
3	满载电压Rated Load output Voltage	11.4-12.6V								
4	满载纹波&噪声 Rated load ripple&noise	≤120mV P-P								
5	额定输入电流 Rated input current	≤1500mA								
6	短路保护 Shortcircuit protection	No damage and auto recovered OK/NG								
7	过流保护 Over current protection	120-200%								
8	介电强度测试 Hi-Pot test	AC3.0KV 5S	<5mA	泄漏电流/Leakage current (mA) ; 绝缘击穿/insulation breakdown: ■OK □NG						
9	绝缘阻抗测试 Insulation resistance	DC500V 5S	>10MΩ	绝缘阻抗/insulation resistance (MΩ) ; 绝缘击穿/insulation breakdown: ■OK □NG						
10	输入/Input		输出/Output				能源之星/Energy star			
	电压 Voltage	功率 Pin(W)	负载% Load%	电压 Vout(V)	电流 Iout(A)	功率 Watt(W)	效率 EFF(%)	平均效率 average Eff(%)	能效标准 VI SPEC	空载功耗 Standby Power(W)
	115Vac		100%						平均效率 AVG EFF ≥87.40% 空载功耗 Standby Power <0.1W	
			75%							
			50%							
			25%							
	230Vac		100%							
			75%							
			50%							
			25%							
11	100V/240V输入时满载开关机测试 Turn on/off test when rated load and input 100V/240Vac		10 times							
12	115-240V 满载老化/Rated load burn-in test at 115V-240Vac		≥4 hours							
测试/TESTED BY		核准/CHECKED BY			批准/APPROVAL BY					