



### Main

Range of product	Modicon X80
Product or component type	Analog output module
Electrical connection	1 connector 20 ways
Input output isolation	Isolated

### Complementary

Measurement error	$\leq 0.25\%$ of full scale 0...60 °C 0.1 % of full scale 25 °C
Temperature drift	40 ppm/°C +/- 10 V 40 ppm/°C 0...20 mA 40 ppm/°C 4...20 mA
Recalibration	Factory calibrated
Isolation voltage	1400 V DC between channels and ground 1400 V DC between channels and bus 750 V DC between channels
Detection type	Open circuit 0...20 mA Open circuit 4...20 mA Short circuit +/- 10 V
Load impedance ohmic	$\leq 600$ Ohm 0...20 mA $\leq 600$ Ohm 4...20 mA $\geq 1000$ Ohm +/- 10 V
Output level	High level
Analogue output number	2
Analogue output type	Current 0...20 mA Current 4...20 mA Voltage +/- 10 V
Analogue output resolution	15 bits + sign
Supply	Internal power supply via rack
Conversion time	$\leq 1$ ms
Maximum conversion value	0...24 mA 0...20 mA 0...24 mA 4...20 mA +/- 11.25 V +/- 10 V +/- 10 V
Fallback mode	Configurable Predefined
Status LED	1 LED green RUN 1 LED per channel green channel diagnostic 1 LED red ERR 1 LED red I/O
Product weight	0.144 kg
Current consumption	150 mA at 3.3 V DC 110 mA at 24 V DC

### Environment

vibration resistance	3 gn
shock resistance	30 gn
ambient air temperature for storage	-40...85 °C
ambient air temperature for operation	0...60 °C

relative humidity	5...95 % 55 °C without condensation
IP degree of protection	IP20
directives	2012/19/EU - WEEE directive 2014/30/EU - electromagnetic compatibility 2014/35/EU - low voltage directive
product certifications	CE CSA UL RCM Merchant Navy EAC
standards	EN 61000-6-2 EN 61000-6-4 EN 61131-2 EN 61010-2-201
protective treatment	TC
operating altitude	0...2000 m 2000...5000 m (with derating factor)

## Offer Sustainability

Sustainable offer status	Green Premium product
RoHS (date code: YYWW)	Compliant - since 0722 - Schneider Electric declaration of conformity
REACH	Reference not containing SVHC above the threshold
Product environmental profile	Available
Product end of life instructions	Available

## Contractual warranty

Warranty period	18 months
-----------------	-----------

## Modules Mounted on Racks

### Dimensions

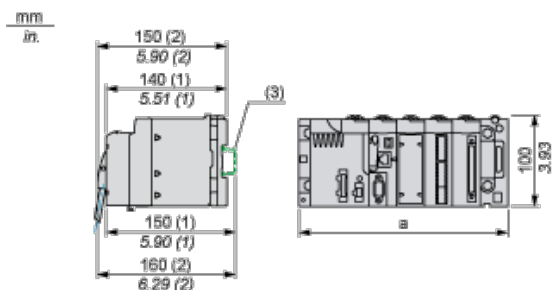

- (1) With removable terminal block (cage, screw or spring).
- (2) With FCN connector.
- (3) On AM1 ED rail: 35 mm wide, 15 mm deep. Only possible with BMXXBP0400/0400H/0600/0600H/0800/0800H rack.

Rack references	a in mm	a in in.
BMXXBP0400 and BMXXBP0400H	242.4	09.54
BMXXBP0600 and BMXXBP0600H	307.6	12.11
BMXXBP0800 and BMXXBP0800H	372.8	14.68
BMXXBP1200 and BMXXBP1200H	503.2	19.81

## Wiring Diagram

Cabling view

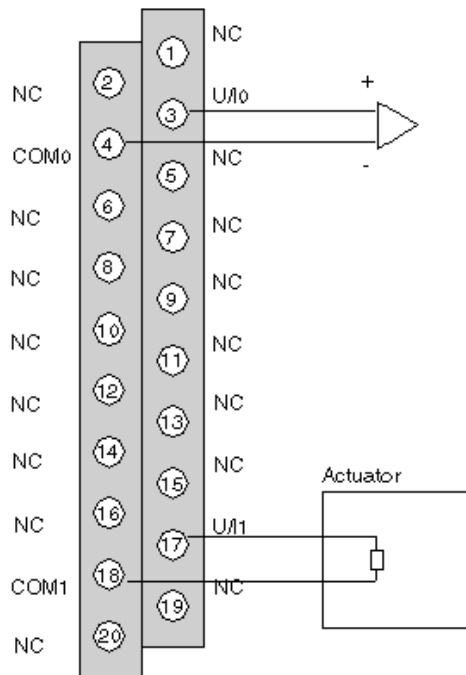

**U/ix** + pole input for channel x

**COMx-** pole input for channel x

**Channel** Voltage actuator

**0**

**Channel** Current actuator

**1**

The current loop is self-powered by the output and does not request any external supply.