



## Main

Range of product	Harmony
Product or component type	Harmony Hub Wireless/Ethernet gateway
Device short name	ZBRN1
Product specific application	Wireless Schneider Electric devices ecosystem
Function of module	Zigbee green power gateway
Antenna type	Integrated

## Complementary

[Us] rated supply voltage	24...240 V AC/DC at 50/60 Hz (- 10...10 %)
Immunity to microbreaks	10 ms
Maximum sensing distance	100 m (in free field) 25 m (transmitter in a plastic box type XAL D and receiver in a metal enclosure) 40 m (transmitter in box type XAL D, receiver in metal enclosure and use relay-antenna) 60 m (transmitter in a plastic box type XAL D and use relay-antenna)
Response time	< 30 ms after transmitter clicks
Power consumption in W	<= 4 W AC/DC
Breaking capacity	15 W
Breaking capacity	750 VA
Control circuit frequency	50...60 Hz +/- 10 %
Short-circuit protection	16 A by GB2 circuit breaker
Operating position	Any position without derating
Electrical connection	1 conductor cable 0.2...4 mm <sup>2</sup> AWG 24...AWG 12 solid without cable end IEC 60947-1 2 conductors cable 0.2...1.5 mm <sup>2</sup> AWG 24...AWG 16 solid without cable end IEC 60947-1 1 conductor cable 0.2...0.75 mm <sup>2</sup> AWG 24...AWG 14 flexible with cable end IEC 60947-1 2 conductors cable 0.2...2.5 mm <sup>2</sup> AWG 24...AWG 18 flexible with cable end IEC 60947-1
Tightening torque	0.35...0.4 N.m conforming to EN/IEC 60947-1
Housing material	Self-extinguishing plastic
Status LED	1 LED (green) : power ON 1 LED (yellow) : communication network 5 LEDs (red) : function mode 1 LED (green and yellow) : reception signal
Mounting support	35 mm symmetrical DIN rail conforming to EN/IEC 60715 Mounting plate
Rated short-duration power frequency withstand voltage	1.5 kV at 50 Hz conforming to EN/IEC 60947-5-1
[Uimp] rated impulse withstand voltage	4 kV
Surge withstand	1 kV (differential mode) conforming to IEC 61000-4-5 2 kV (common mode) conforming to IEC 61000-4-5
Width	122 mm
Height	90 mm
Depth	60 mm
Product weight	0.26 kg
Antenna gain	0 dBi
Integrated connection type	Ethernet Modbus TCP/IP (RJ45 in Modbus TCP network) 10/100 Mbit/s 2 twisted pairs
Data storage equipment	SD card
Topology	Devices linked by daisy-chaining or tap junctions

The information provided in this documentation contains general descriptions and/or technical characteristics of the products contained herein. This documentation is not intended as a substitute for and is not to be used for determining suitability or reliability of these products for specific user applications. It is the duty of any such user or integrator to perform the appropriate and complete risk analysis, evaluation and testing of the products with respect to the relevant specific application or use thereof. Neither Schneider Electric Industries SAS nor any of its affiliates or subsidiaries shall be responsible or liable for misuse of the information contained herein.

Port Ethernet	10BASE-T/100BASE-T
Cable distance between devices	<= 1000 m

## Environment

radio agreement	SRRC ICASA ANATEL type III conforming to ETSI EN 301 489-3 FCC category 2 conforming to ETSI EN 300 440-1 RSS category 1 conforming to ETSI EN 300 440-1
product certifications	CCC CE CSA C-Tick GOST UL
directives	2004/108/EC - electromagnetic compatibility 2006/95/EC - low voltage directive 1999/5/EC - R&TTE directive
standards	EN/IEC 60950-1 EN/IEC 61131-2 UL 508 EN 62311 CSA C22.2 No 14 ETSI EN 300 440-2 ETSI EN 300 328
ambient air temperature for storage	-40...70 °C
relative humidity	90 % (-25...55 °C) without condensation conforming to ETSI EN 300 440-1
operating altitude	0...2000 m
storage altitude	0...3000 m
vibration resistance	+/- 3.5 mm (f= 5...14 Hz) conforming to IEC 60068-2-6 1 gn (f= 5...150 Hz) on panel mounting conforming to IEC 60068-2-6 2 gn (f= 8...150 Hz) on DIN rail conforming to IEC 60068-2-6
shock resistance	10 gn (6000 shocks during 16 ms) conforming to IEC 60068-2-27
IP degree of protection	IP20 (terminals) IP20 (casing) conforming to IEC 60529
pollution degree	2 conforming to IEC 60664-1
electromagnetic compatibility	1.2/50 µs shock waves immunity test :1 kV (differential mode) conforming to IEC 61000-4-5 1.2/50 µs shock waves immunity test :2 kV (common mode) conforming to IEC 61000-4-5 Immunity to microbreaks and voltage drops :10 ms conforming to IEC 61000-4-11
dielectric strength	3000 V AC between input and output 4250 V DC between input and output 1500 V AC between input and ground 2150 V DC between input and ground

## Offer Sustainability

Sustainable offer status	Green Premium product
RoHS (date code: YYWW)	Compliant - since 1402 - Schneider Electric declaration of conformity
REACH	Reference not containing SVHC above the threshold
Product environmental profile	Available
Product end of life instructions	Available

## Access Point

### Dimensions

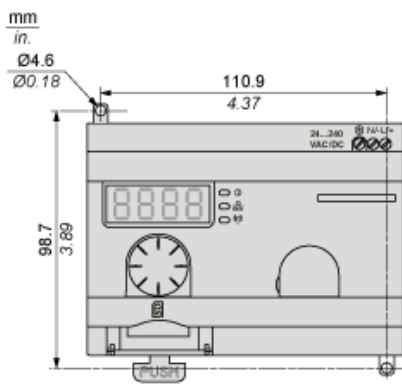

### Access Point on a Mounting Panel

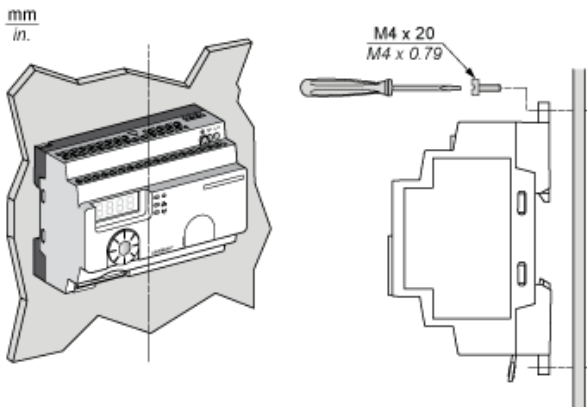

The Access Point is installed according to its vertical axis

### Access Point on DIN rail Mounting

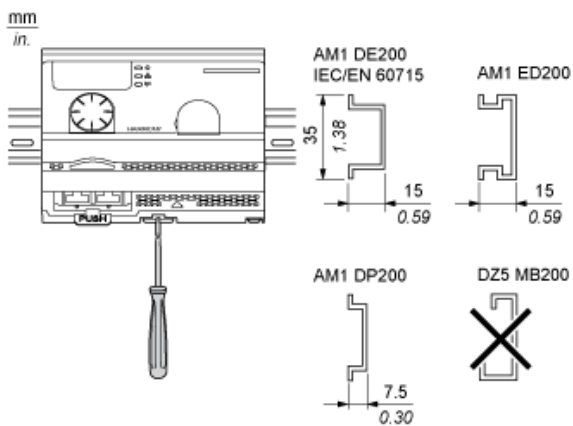

### Clearances

#### Maximum Distance between Transmitter and the Access Point in Free Field Unobstructed

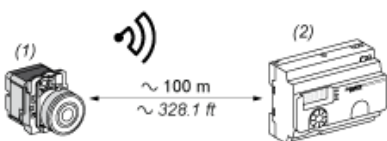

- (1) Transmitter
- (2) Access Point

#### Maximum Distance between Transmitter and the Access Point in a Metal enclosure without a Relay Antenna

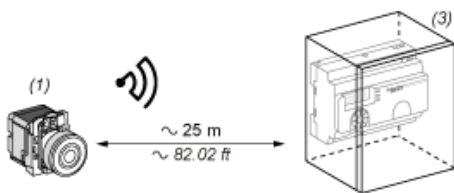

- (1) Transmitter
- (3) Access Point in a Metal enclosure

**Maximum Distance between Transmitter and the Access Point in a Metal Enclosure with a Relay Antenna**

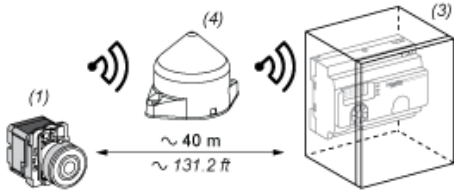

- (1) Transmitter
- (3) Access Point in a Metal enclosure
- (4) Relay Antenna

**Maximum Distance between Transmitter and the Access Point in a Metal Enclosure with a Passive Antenna**

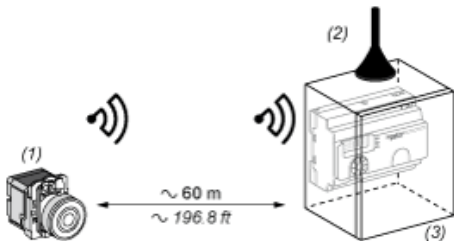

- (1) Transmitter
- (2) External Antenna
- (3) Access Point in a Metal enclosure

The range is reduced if the transmitter is placed in a metal enclosure (reduction factor : approx 10%)

Glass window	10...20 %
Plaster wall	30...45 %
Brick wall	60 %
Concrete wall	70...80 %
Metal structure	50...100 %

**Access Point Clearances**

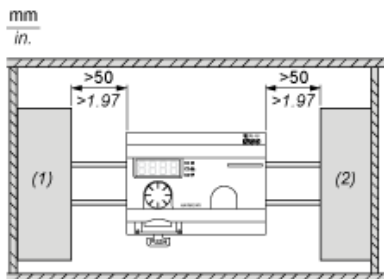

- (1) Power Supply
- (2) Programmable Logic Controller

**Access Point Wiring Diagram**

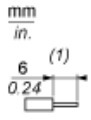
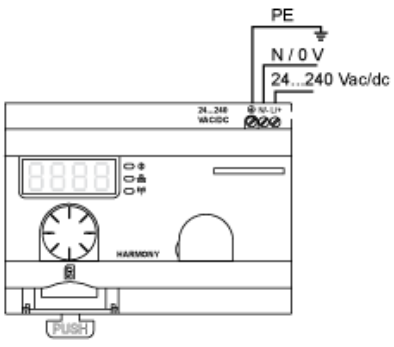

(1) wire sizes for Power Supply terminals (L/+,N/-)