

# XCC1510PSM02X

incremental encoder Ø 58 - solid shaft 10 mm -  
256..4096 points - 5V RS422



## Main

Range of product	OsiSense XCC
Encoder type	Incremental encoder
Encoder name	XCC
Product specific application	-
Diameter	58 mm
Complementary function	Parameterable
Shaft diameter	10 mm
Shaft type	Solid shaft
Resolution	256..4096 points
Output stage	Type X
Type of output stage	Driver 5V, RS422
Electrical connection	1 male connector M23 radial 12 pins
[Us] rated supply voltage	4.75...30 V DC
Enclosure material	Zamak

## Complementary

Residual ripple	500 mV
Maximum revolution speed	9000 rpm
Shaft moment of inertia	10 g.cm <sup>2</sup>
Torque value	0.004 N.m
Maximum load	10 daN radial 5 daN axial
Output frequency	300 kHz
Number of channels	3
Current consumption	0...75 mA (no-load)
Protection type	Reverse polarity protection Short-circuit protection
Maximum output current	40 mA
Output level	Low level: 0.5 V maximum (20 mA) High level: 4.5 V minimum (20 mA)
Surge withstand	1 kV, level 2 conforming to IEC 61000-4-5
Base material	Aluminium
Shaft material	Stainless steel
Type of ball bearings	6000ZZ1
Product weight	0.465 kg

## Environment

marking	CE
ambient air temperature for operation	-30...100 °C
ambient air temperature for storage	-30...85 °C
IP degree of protection	IP65 conforming to IEC 60529
vibration resistance	10 gn (f = 55...2000 Hz) conforming to IEC 60068-2-6
shock resistance	30 gn for 11 ms conforming to IEC 60068-2-27
resistance to electrostatic discharge	8 kV (air discharge) level 3 conforming to IEC 61000-4-2 4 kV (contact discharge) level 3 conforming to IEC 61000-4-2
resistance to electromagnetic fields	10 V/m level 3 conforming to IEC 61000-4-3
resistance to fast transients	1 kV (signal ports) level 3 conforming to IEC 61000-4-4 2 kV (power ports) level 3 conforming to IEC 61000-4-4

The information provided in this documentation contains general descriptions and/or technical characteristics of the performance of the products contained herein. This documentation is not intended as a substitute for and is not to be used for determining suitability or reliability of these products for specific user applications. It is the duty of any such user or integrator to perform the appropriate and complete risk analysis, evaluation and testing of the products with respect to the relevant specific application or use thereof. Neither Schneider Electric Industries SAS nor any of its affiliates or subsidiaries shall be responsible or liable for misuse of the information contained herein.

## Offer Sustainability

Sustainable offer status	Not Green Premium product
RoHS (date code: YYWW)	Compliant - since 0701 - Schneider Electric declaration of conformity
REACH	Reference not containing SVHC above the threshold

## Contractual warranty

Warranty period	18 months
-----------------	-----------

## Dimensions

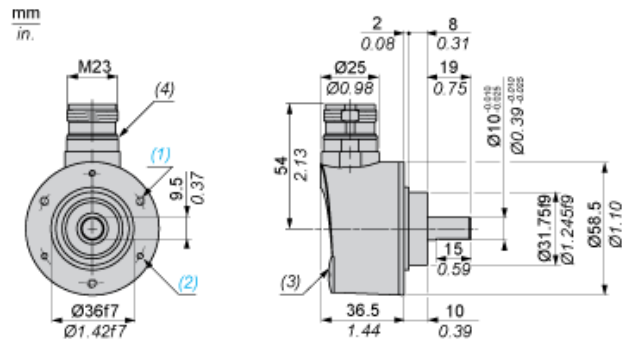

- (1) 3 M4 holes at 120° on 48 PCD, depth: 8 mm
- (2) 3 M3 holes at 120° on 48 PCD, depth: 8 mm
- (3) Blanking plug
- (4) Nitrile seal

## Wiring Diagram

### Type X Output Stage

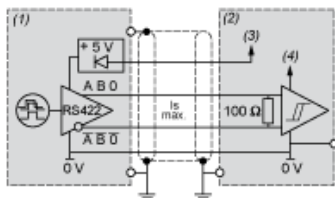

- (1) Encoder
- (2) Processing
- (3) Supply 4.75 V/30 V
- (4) Supply 5 V

## Wiring Diagram

### M23, 12-pin Connector Connections

#### Male Connector on Encoder

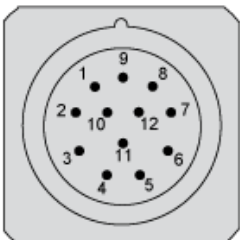

Pin number	1	2	3	4	5	6	7	8	9	10	11	12
Signal Supply	A <sup>-</sup>	+V	0	0 <sup>-</sup>	B	B <sup>-</sup>	R	A	R	0 V	0 V	+V

R = reserved, do not connect

## Wiring Diagram

### Resolutions for Parameterable Ø 58 mm Encoders

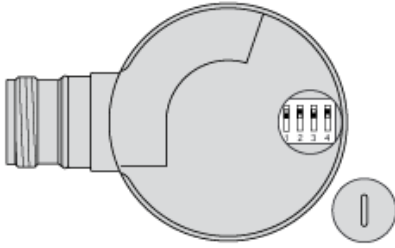

Interpolation factor		Basic resolution					Position of dip switches			
Counting	Speed	256	360	500	1024	5000	1	2	3	4
x1	x1	256	360	500	1024	5000	Off	On	Off	On
x2	x2	512	720	1000	2048	10,000	On	On	Off	On
x3	x3	768	1080	1500	3072	15,000	On	Off	Off	On
x4	x4	1024	1440	2000	4096	20,000	Off	On	On	On
x5	-	1280	1800	2500	5120	25,000	On	On	On	On
x8	-	2048	2880	4000	8192	40,000	On	Off	On	On
x10	-	2560	3600	5000	10,240	50,000	Off	On	On	Off
x12	-	3072	4320	6000	12,288	60,000	On	On	On	Off
x16	-	4096	5760	8000	16,384	80,000	On	Off	On	Off