

multicomp PRO



Loop Calibrator

Model No. MP700005

IMPORTANT SAFETY INFORMATION

Read all instructions before using the appliance and retain for future reference.

- Please follow all safety operation instructions.
- Check the test leads, probes and case insulation before using. If you find any breakage or abnormality, or you consider the device is broken, stop using the device immediately.
- Output a test voltage to confirm the calibrator is working properly before use.
- Select the proper function and range according to the measurement requirements.
- Before using the calibrator, make sure the battery cover is closed.
- When using the probes, do not touch the metal part of the probes. Keep your fingers behind the finger guards on the probes.
- Always connect the common test lead first then the live test lead. Remove the live test lead first when disconnecting.
- Disconnect the test leads before switching to other measurements or outputs.
- Do not apply <math><30V</math> between any terminal and ground or between two terminals.
- Children should be supervised to ensure that they do not play with the product.
- Do not use the product for any purpose other than that for which it is designed.
- Do not operate the product around explosive gas, vapour, or dust.
- Do not operate or store in an environment of high humidity or where moisture may enter the product as this can reduce insulation and lead to electric shock.
- Turn the meter off when not in use to save the battery.
- Remove the battery if the meter is not to be used for long periods.
- Remove the test leads on the calibrator before opening the battery cover.
- Replace the battery as soon as the low battery warning appears on the display to avoid possible electric shock or personal injury caused by incorrect readings.

WHAT'S INCLUDED

- Calibration meter
- Battery.
- Instruction manual.
- Test leads.
- Alligator clip.

PRODUCT OVERVIEW

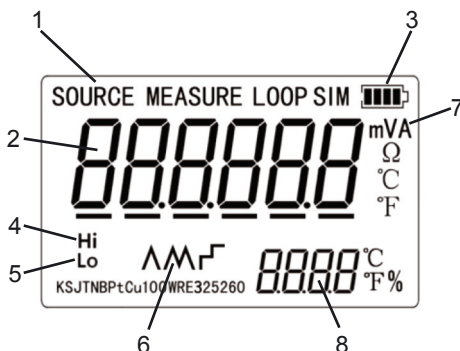

1. Source/Measure/Loop/Sim indicator
2. Main display
3. Low battery indicator
4. Excitation current too high
5. Excitation current too low
6. Ramp/Step indicator
7. Voltage unit
8. Percentage of source/measurement value

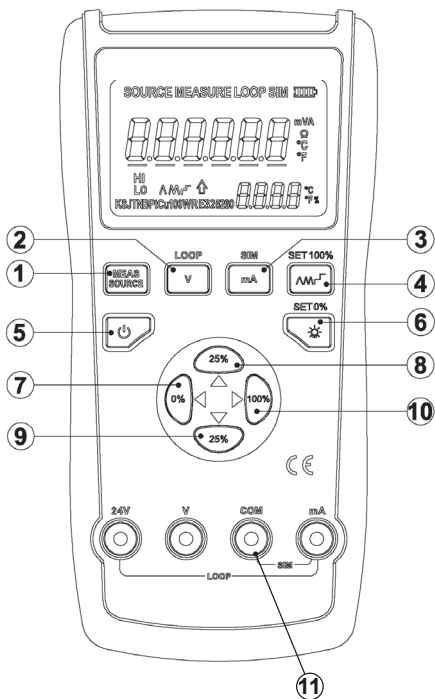

1. Measure/Source Mode button
2. Voltage/Current Mode button
3. mA current selection button
4. SLOPE/STEP mode button
5. Power ON/OFF button
6. Backlight/Current to 0% button
7. 0% Value Setting button
8. +25% Value Setting button
9. 100% Value Setting button
10. -25% Value Setting button
11. Test lead connection terminals

FUNCTIONS

Source

- Connect the red test lead to V terminal, black to COM terminal, then connect the red probe to positive terminal of external voltage source, black to negative terminal.
- Press the POWER button (>2s) to turn on the calibrator and it will perform self-test, which includes the internal circuit and LCD display testing. The LCD screen will display all symbols for 1s during self-test.
- Press V button to switch to voltage measurement mode.
- Briefly press the UP or DOWN (25%) value buttons to add or subtract 1 for the value above the underline (the value is automatically carried and the position of the underline remains unchanged) and press LEFT (0%) or RIGHT (100%) to change the position of the underline.
- Use value buttons to adjust the output value to 10mA then press BACKLIGHT button until the buzzer makes a short beep and 10mA is stored as the value of 0%.
- Press UP (25%) value button to increase the output to 20mA then press SLOPE/STEP button until the buzzer makes a short beep and the 20mA will be saved as the value of 100%.
- Long press UP or DOWN (25%) buttons to increase or decrease the output between 0% and 100% in 25% steps.

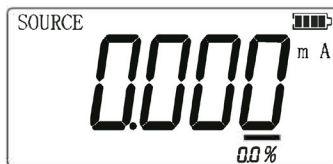

Auto Power Off

- The calibrator will automatically shut down if there is no button or communication operation within the 30min (factory setting), which is enabled by default and is displayed for about 2s during the booting process.
- To disable auto power off, press down LEFT (0%) value button while turning on the calibrator until the buzzer beeps.
To enable auto power off, press down RIGHT (0%) value button while turning on the calibrator until the buzzer makes a “beep” sound.
- To adjust the auto power off time, press down RIGHT (0%) value button while turning on the calibrator until the buzzer beeps, then adjust the time between 1-30 min with the UP or DOWN (25%) value buttons, then short press BACKLIGHT button to save the setting (if the time is not saved, the calibrator will exit settings mode automatically in 5 seconds) and then enter the operating mode.

Backlight Brightness Control

- Press and hold the BACKLIGHT button while turning on the calibrator until the buzzer makes a “beep” sound.
- Then adjust the backlight brightness by using the UP or DOWN (25%) value buttons, the brightness value is displayed on the screen as shown:
- Long press BACKLIGHT button to save the setting (if the settings are not saved, the calibrator will exit settings mode automatically in 5 seconds) and then enter the operating mode.

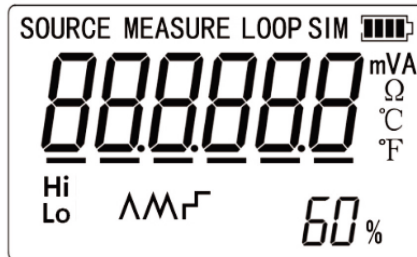

OPERATION

Voltage Measurement

- Short press MEASURE/SOURCE and select Measure, then press V and the LCD displays 'V' unit.
- Connect the red test lead to V terminal, black to COM terminal.
- Connect the test probes to the voltage points to be tested: connect the red probe to the positive terminal, black to negative terminal.
- Read the data on the LCD screen.

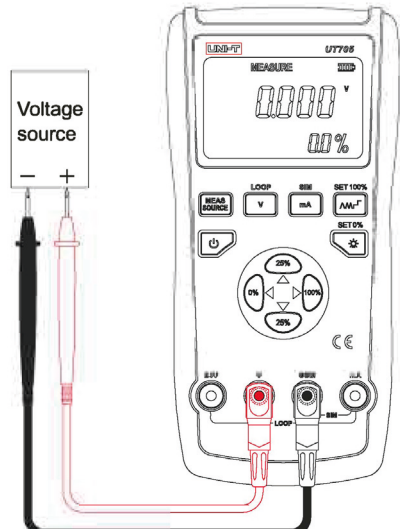

Current Measurement

- Short press MEASURE/SOURCE and select Measure, then press mA button and the LCD displays 'mA' unit.
- Connect the red test lead to mA terminal, black to COM terminal.
- Disconnect the circuit path to be tested, and then connect the test probes to the joints: connect the red probe to positive terminal, black to negative terminal.
- Read the data on the screen.

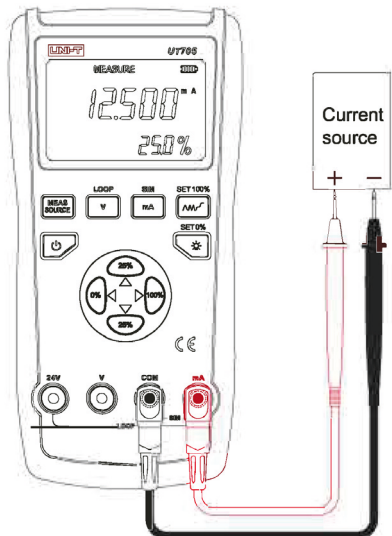

Loop Current Measurement with Loop Power

- The loop power function activates a 24V power supply in series with the current measuring circuit inside the calibrator, allowing you to test the transmitter out of the field power supply of the 2-wire transmitter.
- The steps are as follows:
- Press MEASURE/SOURCE button to select the measure function and the LCD will display 'MEASURE'.
- Long press V button and the LCD will display 'MEASURE LOOP', the unit is V.
- Connect the red test lead to the 24V terminal, black to mA terminal.
- Disconnect the circuit path to be tested.
- Connect the red probe to positive terminal and black to the negative terminal of the 2-wire transmitter.
- Read the data on the screen.

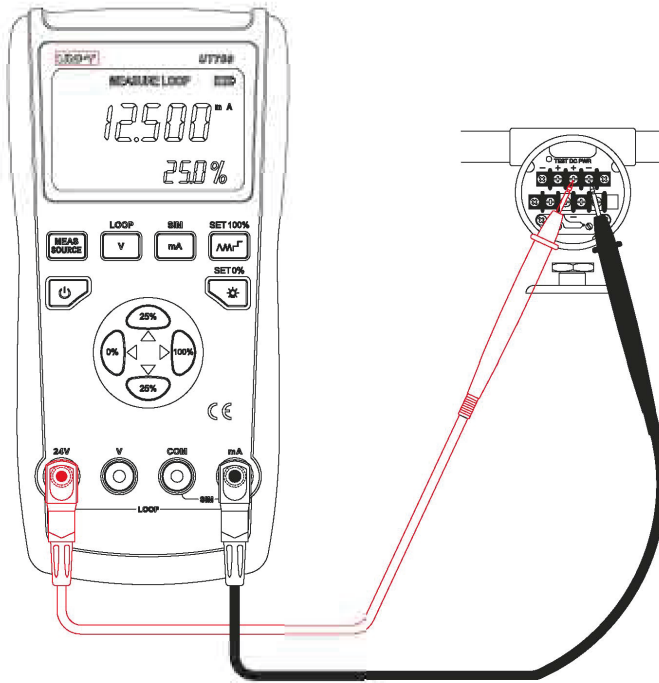

Current Source Output

- Press MEASURE/SOURCE button to select the source function and the LCD will display 'SOURCE'.
 - Press mA button and 'mA' is displayed on the LCD.
 - Connect the red test lead to mV terminal, black to COM terminal.
 - Connect the red probe to the ammeter positive terminal, black to the ammeter negative terminal.
 - Select an output digit by using LEFT (0%) or RIGHT (100%) value buttons, and adjust its value with the UP or DOWN (25%) value buttons.
 - Read the data on the ammeter.
-
- When the current output is overloaded, LCD will display the 'Hi' overload indicator, and the value on the main display will flash.

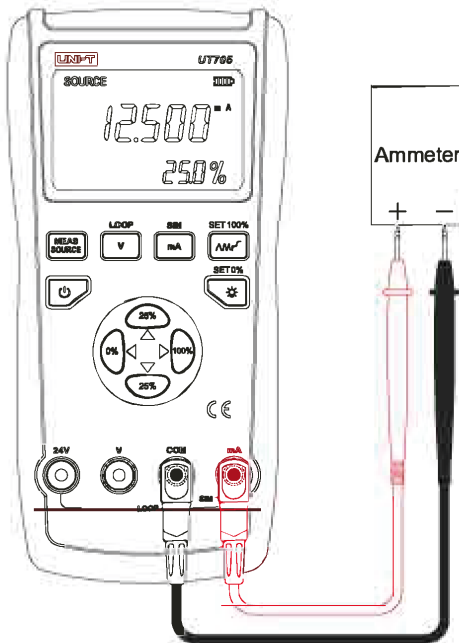

Simulating Transmitter

- Simulating the 2-wire transmitter is a special operation mode in which the calibrator is connected to the application loop instead of the transmitter, and provides a known and configurable test current. The steps are as follows:
- Press MEASURE/SOURCE button to select the source function and the LCD will display 'SOURCE'.
- Long press mA button and the LCD will display 'SOURCE SIM', the unit is mA.
- Connect the red test lead to mA terminal, black to COM terminal.
- Connect the red probe to positive terminal of the external 24V power supply, black to ammeter positive terminal; then connect the ammeter negative terminal to the negative terminal of the external 24V power supply.
- Select an output digit by LEFT (0%) or RIGHT (100%) value buttons, and adjust its value with UP or DOWN (25%) value buttons.
- Read the data on the ammeter.

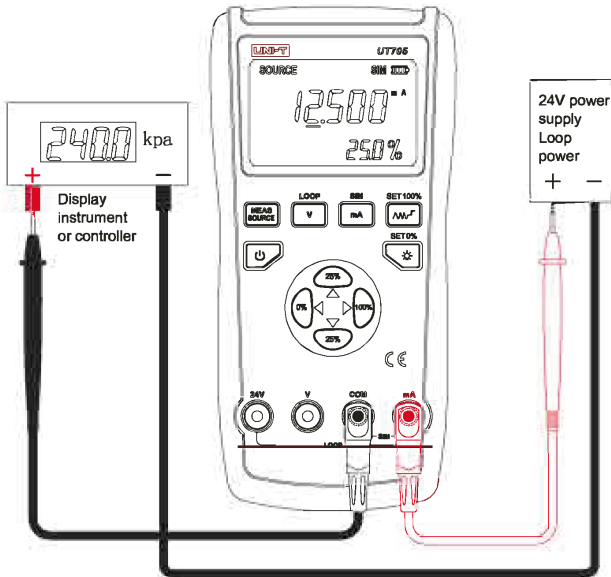

ADVANCED APPLICATIONS

Setting 0% and 100% Output Parameters

- Users need to set the values of 0% and 100% for the step operation and percentage display. Some values of the calibrator have been set as default.
- The table below lists the factory settings.

Output Functions	0% value	100% Value
Current	4.000mA	20.000mA

- These factory settings may not be suitable for your work, you can reset them according to your requirements.
- Adjust the output value with four VALUE buttons, long press BACKLIGHT or SLOPE/STEP until the buzzer makes a “beep” sound to set the new values of 0% and 100%. The newly set range is automatically saved in the calibrator storage area, and it is still valid after restarting.
- Now you can use the settings to do the following:
- Long press UP or DOWN (25%) to manually step (increase or decrease) the output in 25% increments.
- Long press LEFT (0%) or RIGHT (100%) to switch the output between 0% and 100% range.

Auto Ramping (inc/dec) the Output

- The auto ramping function allows you to continuously apply a varying signal from the calibrator to the transmitter and view the calibrators response.
- Press the SLOPE/STEP button and the calibrator will generate a continuous and repeating 0% - 100% ramping output.
- Three types of ramping waveforms are available:
 1. 0%-100%-0% 40 second smooth ramp
 2. 0%-100%-0% 15 second smooth ramp
 3. 0%-100%-0% 25% step ramp pausing for 5 seconds at each step
- Press any key to exit the ramping output function.

Restore Factory Settings

- Long press the RTD button while powering on the calibration until the buzzer sounds. After the factory reset is completes the calibrator will automatically enter into the operating mode.
- The following factory settings are restored:
 1. Operating mode: voltage output mode
 2. Auto power off time: 30 mins (enabled)
 3. LCD backlight brightness: 60%
 4. Output range

SPECIFICATIONS

- All specifications are based on a one year calibration period and applied to a working temperature range of +18°C~+28°C unless otherwise specified. All specifications are obtained after a 30 minute period of operation.

Max voltage between any terminal and ground or between any two terminals: 30V

Range: manual

Operating temperature: 0°C~50°C (32°F~122° F)

Storage temperature: -20°C~70°C (-4°F~158° F)

Relative humidity: <95% (0°C~30°C), <75% (30°C~40°C), <50% (40°C~50°C)

Operating altitude: 0-2000m

Battery: 9Vx1

Dimension: about 96x193x47mm

Weight: about 370g (including battery)

DC Voltage Measurement

Range	Max measurement range	Resolution	Accuracy \pm (% reading + digits)
30V	0V~31V	0.001V	0.02%+2
-10°C~18°C, +28°C~55°C temperature coefficient: \pm 0.005%FS/°C Input resistance: >1M Ω			

DC Current Measurement

Range	Max measurement range	Resolution	Accuracy \pm (% reading + digits)
24mA	0~24mA	0.001mA	0.02%+2
24mA Loop	0~24mA	0.001mA	0.02%+2
-10°C~8°C, +28°C~55°C temperature coefficient: \pm 0.005%FS/°C Input resistance: <100 Ω			

DC Current Output

Range	Max measurement range	Resolution	Accuracy \pm (% reading + digits)
24mA	0~24mA	0.001mA	0.02%+2
24mA Simulating Transmitter	0~24mA	0.001mA	0.02%+2
-10°C~18°C, +28°C~55°C temperature coefficient: \pm 0.005%FS/°C Max load voltage: 20V, equivalent to the voltage of 20mA current on 1000 Ω load.			

24V Power Supply: Accuracy: 10%

MAINTENANCE

Warning: Before opening the rear cover or the battery cover, power the instrument down and remove the test leads from any device or circuit under test and remove the test leads from the input terminals

- If the low battery symbol illuminates on the LCD, this indicates that the battery power is less than 20%.
- Please replace the 9V battery with the same type of battery, otherwise the measurement accuracy might be affected.

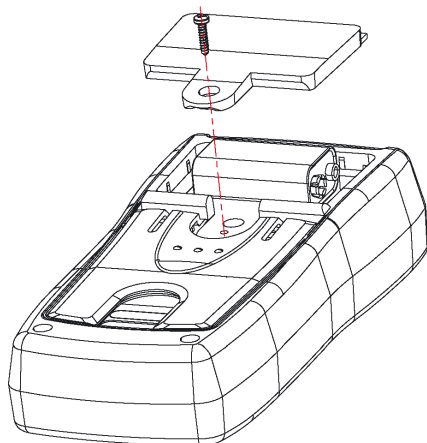

CLEANING

- Clean the meter with a clean, soft cloth.
- Do not use any chemicals, abrasives or solvents that could damage the meter.



INFORMATION ON WASTE DISPOSAL FOR CONSUMERS OF ELECTRICAL & ELECTRONIC EQUIPMENT.

These symbols indicate that separate collection of Waste Electrical and Electronic Equipment (WEEE) or waste batteries is required. Do not dispose of these items with general household waste. Separate for the treatment, recovery and recycling of the materials used. Waste batteries can be returned to any waste battery recycling point which are provided by most battery retailers. Contact your local authority for details of the battery and WEEE recycling schemes available in your area.



Made in China. LS12 2EN
Man Rev 1.0