

General Description

The TMR1202 is a digital bipolar magnetic switch that integrates TMR and CMOS technology in order to provide a magnetically triggered digital switch with high sensitivity, high speed, and ultra-low power consumption. It integrates a push-pull half-bridge TMR magnetic sensor and CMOS signal processing circuitry within the same package. Designed for use in applications that are both power-critical and performance-demanding, this device includes an on-chip TMR voltage generator for precise magnetic sensing, TMR voltage amplifier and comparator, a Schmitt trigger to provide switching hysteresis for noise rejection, and CMOS push-pull output. An internal band gap regulator is used to provide temperature compensated supply voltage for internal circuits, and it allows a wide range of operating supply voltages. The TMR1202 draws only 1.5 μ A resulting in ultra-low power operation, additionally it has fast response, accurate switching points, excellent thermal stability, and immunity to stray field interference. It is available in two packaging form factors: SOT23-3 (P/N TMR1202S), or TO-92S (P/N TMR1202T).

Features and Benefits

- Tunneling Magnetoresistance (TMR) Technology
- Ultra Low Power Consumption at 1.5 μ A
- High Frequency Response at 1KHz
- Bipolar Latching Operation
- Low Operate Points for High Sensitivity
- Compatible with a Wide Range of Supply Voltages
- Excellent Thermal Stability
- High Tolerance to External Magnetic Field Interference

Applications

- Utility Meters including Water, Gas, and Heat Meters
- Solid State Switches
- Speed Sensing
- Rotary and Linear Position Sensing



TMR1202S(Left), TMR1202T(Right)

Block Diagram

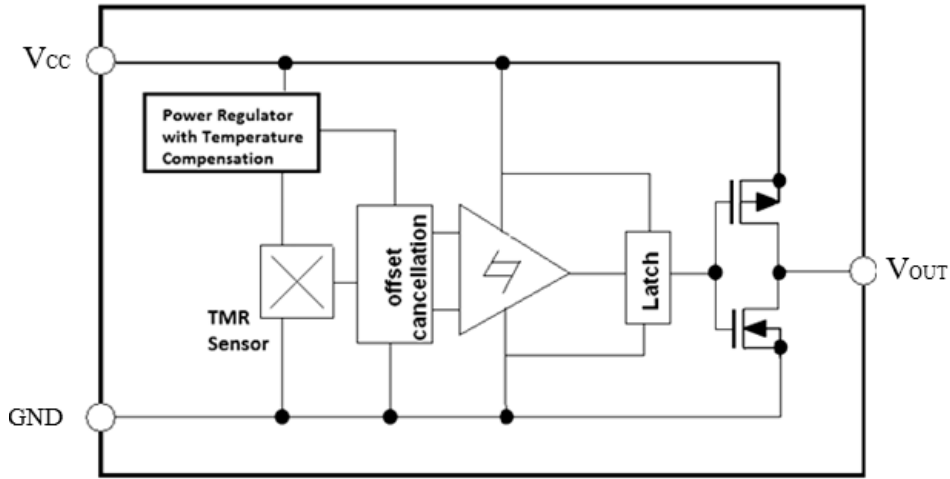

Pin Configuration

TO-92S

SOT23-3

Pin Name	Pin No.		Pin Function
	TO-92S	SOT23-3	
V_{OUT}	1	2	Output
GND	2	3	Ground
V_{CC}	3	1	Supply Voltage

Absolute Maximum Ratings

Parameter	Symbol	Limit	Unit
Supply Voltage	V_{CC}	7	V
Reverse Supply Voltage	V_{RCC}	0.3	V
Output Current	$I_{OUTSINK}$	9	mA
Magnetic Flux Density	B	2800	G
ESD level(HBM)	V_{ESD}	2	kV
Operating Temperature	T_A	-40 ~ 125	°C
Storage Temperature	T_{stg}	-50 ~ 150	°C

Electrical Characteristics ($V_{CC}=3.0V, T_A=25^{\circ}C$)

Parameter	Symbol	Conditions	Min	Typ.	Max	Unit
Supply Voltage	V_{CC}	Operating	1.8	3.0	5.5	V
Output High Voltage	V_{OH}		$V_{CC}-0.3$		V_{CC}	V
Output Low Voltage	V_{OL}		0		0.2	V
Supply Current	I_{CC}	Output Open		1.5		μA
Response Frequency	F			1000		Hz

Note: A 0.1 μF capacitor is connected between V_{CC} and GND during all tests in the above table.

Magnetic Characteristics ($V_{CC} = 3.0V, T_A = 25^\circ C$)

Parameters	Symbol	Min	Typ.	Max	Units
Operate Point	B_{OP}		17		G
Release Point	B_{RP}		-17		G
Hysteresis	B_H		34		G

Voltage and Temperature Characteristics

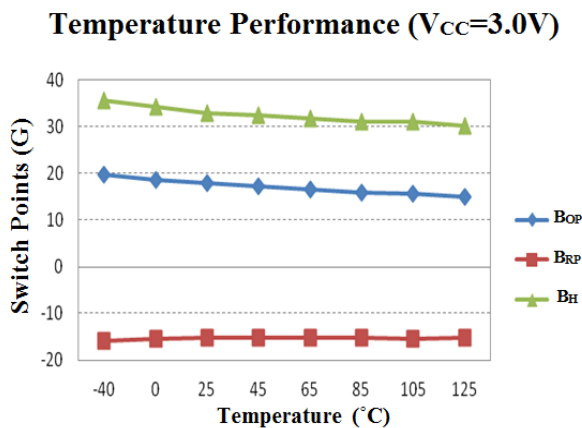
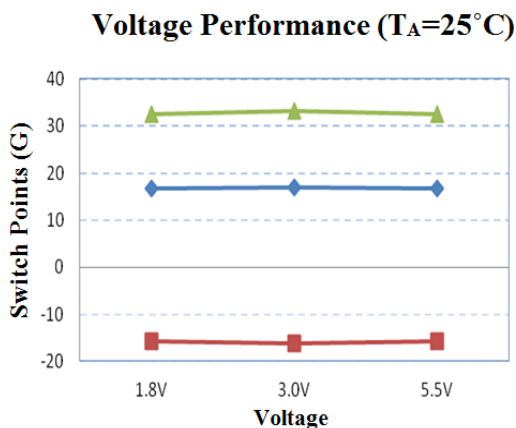

Output Behavior vs. Magnetic Pole

Parameter	Test Conditions	Output
South Pole	$B > B_{OP}$	Low (On)
North Pole	$B < B_{RP}$	High (Off)

Note: when power is turned on under zero magnetic field, the output is "High".

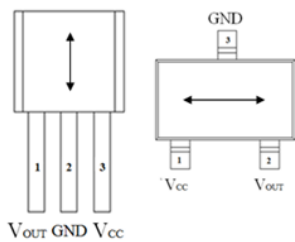

Sensing Direction of Magnetic Field

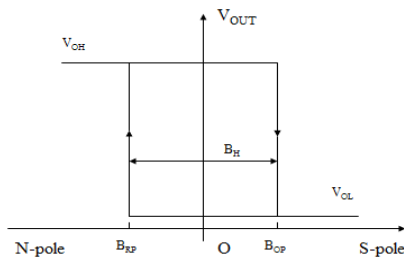

Magnetic Flux

Application Information

The output of the TMR1202 switches low (turns on) when a magnetic field parallel to the TMR sensor exceeds the operate point threshold, B_{OP} . When the magnetic field is reduced below the release point, B_{RP} , the device output goes high (turns off). The difference between the magnetic operate point and release point is the hysteresis B_H of the device.

It is strongly recommended that an external bypass capacitor be connected in close proximity to the device between the supply and ground to reduce noise. The typical value of the external capacitor is 0.1 μF .

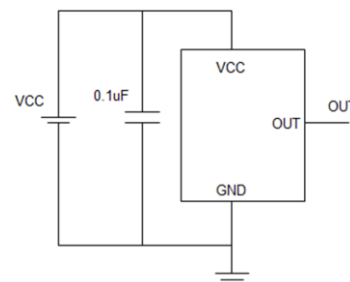

Package Information

SOT23-3 package drawing

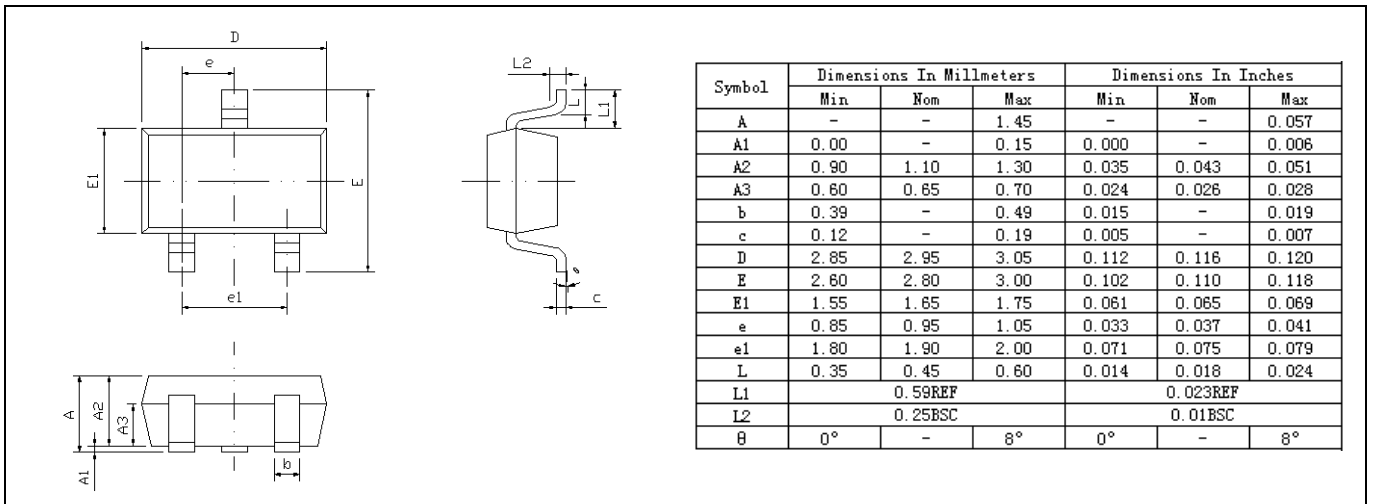

TO-92S package drawing

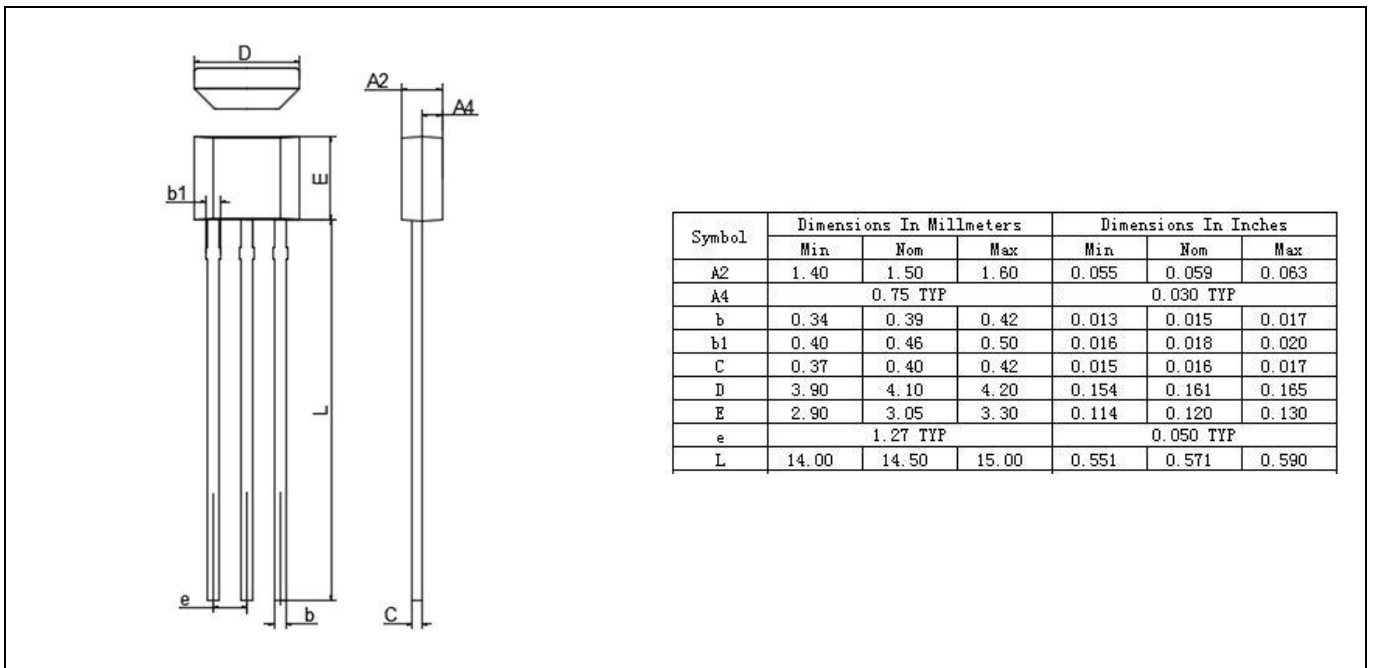

TMR Sensor Position

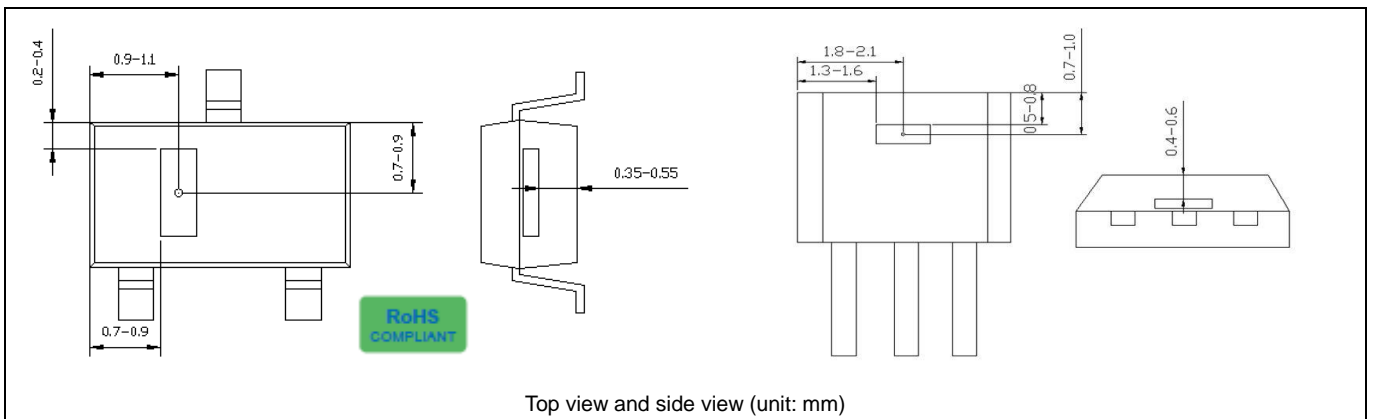



American Electronic Components Inc.,

Address: 1101 Lafayette Street, Elkhart, Indiana 46516, United States of America.

Web: www.aecensors.com

Email: sales@aecensors.com

The information provided herein by MultiDimension Technology Co., Ltd. (hereinafter MultiDimension) is believed to be accurate and reliable. Publication neither conveys nor implies any license under patent or other industrial or intellectual property rights. MultiDimension reserves the right to make changes to product specifications for the purpose of improving product quality, reliability, and functionality. MultiDimension does not assume any liability arising out of the application and use of its products. MultiDimension's customers using or selling this product for use in appliances, devices, or systems where malfunction can reasonably be expected to result in personal injury do so at their own risk and agree to fully indemnify MultiDimension for any damages resulting from such applications.