



Main

Range of product	Preventa Safety detection
Accessory / separate part designation	Laser alignment tool
Accessory / separate part type	Laser
Accessory / separate part category	Installation accessories
Accessory / separate part destination	Safety light curtain type 2 Safety light curtain type 4

Complementary

Product weight	0.8 kg
----------------	--------

Offer Sustainability

Sustainable offer status	Green Premium product
RoHS (date code: YYWW)	Compliant - since 1425 - Schneider Electric declaration of conformity Schneider Electric declaration of conformity
REACH	Reference not containing SVHC above the threshold Reference not containing SVHC above the threshold
Product environmental profile	Available Product Environmental Profile
Product end of life instructions	Available End of Life Information

Disclaimer: This documentation is not intended as a substitute for and is not to be used for determining suitability or reliability of these products for specific user applications

Dimensions

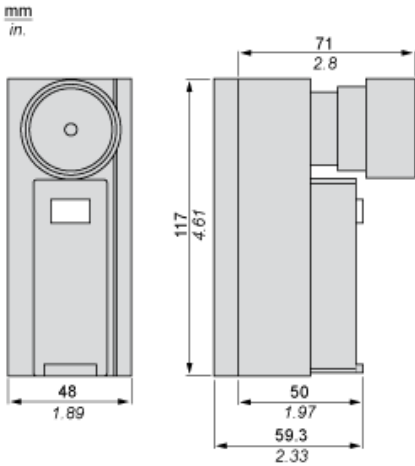

Mounting and Clearance

Laser Alignment Device

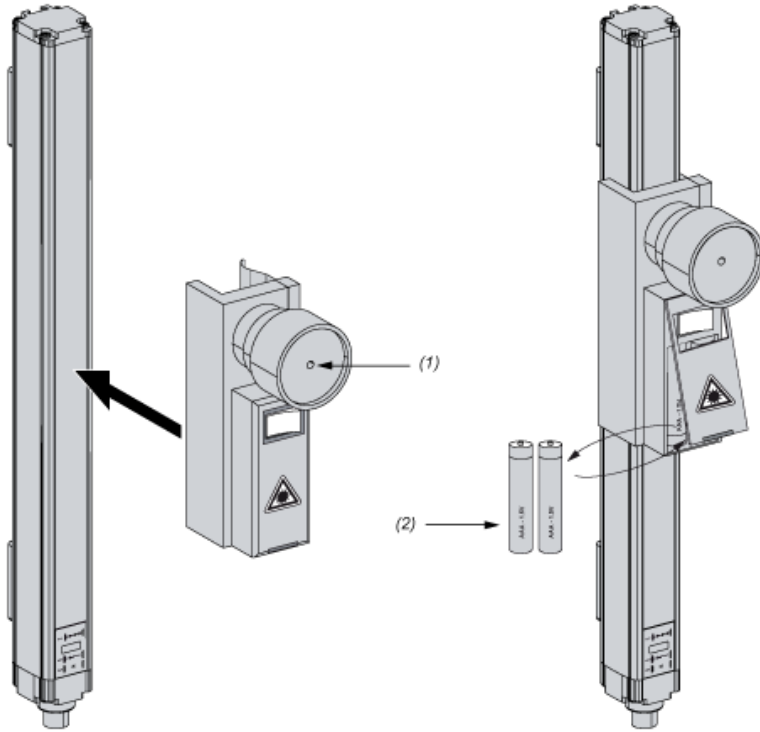

- (1) Position of the laser beam
- (2) 2 AAA batteries (not part of package)