



Main

Range of product	OsiSense XG
Product or component type	Compact smart antenna
RFID compact station name	XGCS
RFID frequency	13.56 MHz
Design	80 x 93 x 40
Electrical connection	4 pin(s) male power supply socket M8 4 pin(s) female Ethernet socket 1 M12 4 pin(s) female Ethernet socket 2 M12
Transmission rate	10...100 Mbit/s
Outer dimension	80 x 93 x 40 mm
Product compatibility	RFID microchip INSIDE (micropass) RFID microchip STM (CRIX4K) RFID microchip Texas (Tag-it HFI) RFID microchip Fujitsu (MB89R118 - MB89R119) RFID microchip NXP (SL2, SL1, Ultralight, Std 1K/4K, Desfire) RFID microchip Microelectronic (EM4135)
[Sn] nominal sensing distance	20...100 mm
[Us] rated supply voltage	24 V DC conforming to Protective Extra Low Voltage

Complementary

Communication port protocol	Ethernet IP/Modbus TCP
Communication port support	Ethernet
Associated tag type	Automatic detection of the type of tag ISO 14443 standard tags ISO 15693 standard tags
Supply voltage limits	19.2...29 V DC
Current consumption	< 150 mA
Status LED	1 LED (red/green) for operation 1 LED (red/green) for RFID communication 2 LEDs (red/green) for Ethernet network activity 1 LED (red/green) for status 1 LED (red/green) for Module Status
Tightening torque	< 3 N.m
Marking	CE
Product weight	0.36 kg

Environment

Product certifications	UL, FCC
Standards	EN/IEC 61000-6-3 FCC CFR 47 part 15 RoHS compliant EN 50364 EN 62369-1 ETSI EN 301 489-1 ETSI EN 301 489-3 ETSI EN 300 330-1 ETSI EN 300 330-2
Ambient air temperature for operation	-25...70 °C
Ambient air temperature for storage	-40...85 °C
IP degree of protection	IP65 conforming to IEC 60529
Vibration resistance	2 mm (f = 5...29.5 Hz) conforming to EN 60068-2-6 7 gn (f = 29.5...150 Hz) conforming to EN 60068-2-6
Shock resistance	30 gn for 11 ms conforming to EN 60068-2-27
IK degree of protection	IK02 conforming to EN 50102
Electromagnetic compatibility	Electrostatic discharge immunity test for contact discharge (level: 3) - test level 6 kV conforming to IEC 61000-4-2 Electrostatic discharge immunity test for air discharge (level: 3) - test level 8 kV conforming to IEC 61000-4-2 Susceptibility to electromagnetic fields (level: 3) - test level 10 V/m conforming to IEC 61000-4-3 Electrical fast transient/burst immunity test for signal ports (level: 3) - test level 1 kV conforming to IEC 61000-4-4 Electrical fast transient/burst immunity test for power ports (level: 3) - test level 2 kV conforming to IEC 61000-4-4 1.2/50 µs shock waves immunity test (level: 3) - test level 10 kV conforming to IEC 61000-4-5 Conducted RF disturbances (level: 3) - test level 10 V conforming to IEC 61000-4-6 Magnetic field at power frequency (level: 4) - test level 30 A/m conforming to IEC 61000-4-8

Dimensions

Compact Smart Antennas

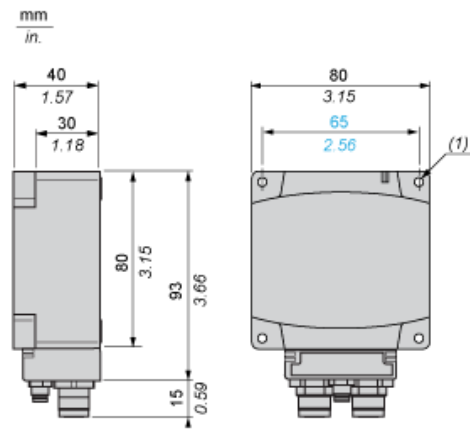

(1) 4 x Ø 5.5. For CHC type screws

Minimum Mounting Distances

Distance Between Smart Antennas

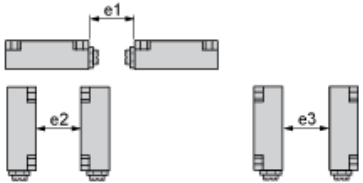

Tag	e1	e2	e3
XGHB90E340 XGHB520246	430	750	280
XGHB221346	280	530	260
XGHB320***	310	540	240
XGHB211345 XGHB123345	200	370	170
XGHB44***	310	400	160

Minimum Mounting Distances in a Metal Structure

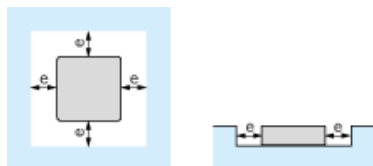

(e) ≥ 20 mm.

Wiring Diagram

Ethernet Connections

Socket to Ethernet cabling (M12 connectors)

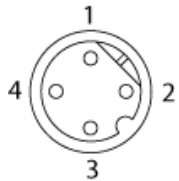

Pin no.	Signal
1	TD+
2	TD-
3	RD+
4	RD-

Socket to power supply cabling (M8 connector)

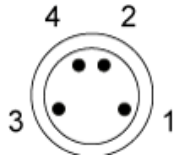

Pin no.	Signal
1	+ 24 VDC
2	NC
3	0 VDC
4	NC

Curves

Dialogue Zones of Compact Smart Antennas

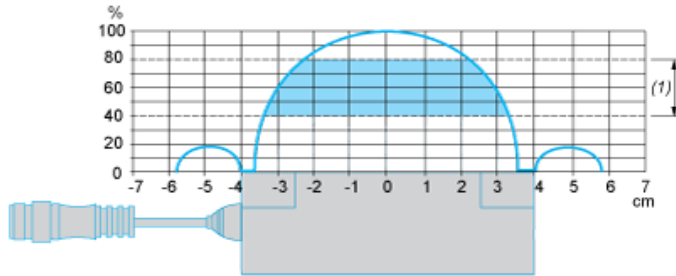

(1) Recommended movement zone: between 0.4 and 0.8 Pn.