



Main

Range of product	Magelis SCU
Product or component type	Small touch HMI controller
Display size	3.5 inch
Display type	With backlit LED colour TFT LCD
Touch panel	Analogue
Device presentation	Complete product

Complementary

Display resolution	320 x 240 pixels QVGA
Backlight lifespan	50000 hours with 65000 colours
Brightness	16 levels via touch panel
View angle horiz x vert	60° left 60° right 40° top 60° bottom
Character font	ASCII Chinese (simplified Chinese) Japanese (ANK, Kanji) Korean Taiwanese (traditional Chinese)
Supply	External source
[Us] rated supply voltage	24 V at 20.4...28.8 V DC
Immunity to microbreaks	<= 10 ms
Inrush current	<= 30 A
Power consumption in W	15 W
Local signalling	No indicator
Number of pages	Limited by internal memory capacity
Software designation	SoMachine
Operating system	Magelis

Processor name	CPU RISC
Processor frequency	333 MHz
Memory description	128 MB flash memory, type: NAND 128 kB internal data storage memory, type: FRAM 128 MB application run memory, type: DRAM
Integrated connection type	1 RJ45 connector serial link with RS232/RS485 interface at <= 115.2 kbits/s 1 RJ45 connector Ethernet TCP/IP 1 USB 2.0 type mini B 1 USB 2.0 type A SUB-D 9 connector CANopen master bus
Realtime clock	Built-in
Downloadable protocols	Modbus Modbus TCP/IP CANopen
Fixing mode	By 1 nut - diameter: Ø 22 mm, mounting on: 1...6 mm thick panel
Enclosure material	PC/PBT
Shock resistance	147 m/s ² (duration=11 ms) conforming to IEC 60068-2-27 on DIN rail 294 m/s ² (duration=6 ms) conforming to IEC 60068-2-27 on panel mounting
Vibration resistance	+/- 3.5 mm (f=5...9 Hz) conforming to IEC 60068-2-6 1 gn (f=9...150 Hz) conforming to IEC 60068-2-6
Electromagnetic compatibility	Electrostatic discharge immunity test - test level: 8 kV, air discharge conforming to IEC 61000-4-2 Electrostatic discharge immunity test - test level: 6 kV, contact discharge conforming to IEC 61000-4-2 Susceptibility to electromagnetic fields - test level: 10 V/m, 80 MHz...3 GHz conforming to IEC 61000-4-3 Electrical fast transient/burst immunity test - test level: 2 kV, power lines conforming to IEC 61000-4-4 Electrical fast transient/burst immunity test - test level: 1 kV, between analogue I/O and operating voltage conforming to IEC 61000-4-4 Electrical fast transient/burst immunity test - test level: 2 kV, relay wires conforming to IEC 61000-4-4 Electrical fast transient/burst immunity test - test level: 1 kV, Ethernet line conforming to IEC 61000-4-4 Electrical fast transient/burst immunity test - test level: 1 kV, COM line conforming to IEC 61000-4-4 Electrical fast transient/burst immunity test - test level: 1 kV, CAN line conforming to IEC 61000-4-4 Surge immunity test - test level: 2 kV, power supply (common mode) conforming to IEC 61000-4-5 Surge immunity test - test level: 1 kV, power supply (differential mode) conforming to IEC 61000-4-5 Surge immunity test - test level: 1 kV common mode, digital I/O conforming to IEC 61000-4-5 Surge immunity test - test level: 0.5 kV differential mode, digital I/O conforming to IEC 61000-4-5 Conducted RF disturbances - test level: 10 V, 0.15...80 MHz conforming to IEC 61000-4-6 Conducted emission - test level: 150 kHz...30 MHz conforming to EN 55011 Radiated emission - test level: 30 MHz...1 GHz conforming to EN 55011
Discrete input number	2 for fast input (normal mode) conforming to IEC 61131-2 Type 1 6 for digital input conforming to IEC 61131-2 Type 1
Discrete input voltage	24 V DC discrete input logic:sink or source (positive/negative)
Number of common point	1 for fast input (HSC mode) 1 for digital input
Discrete input current	7.83 mA for fast input 5 mA for digital
Input impedance	4.7 kOhm 2.81 kOhm
Sensor power supply	15...28.8 V DC, voltage (state 1): >= 15 V, current (state 1): >= 5 mA, voltage (state 0): <= 5 V, current (state 0): <= 1.5 mA 15...28.8 V DC, voltage (state 1): >= 15 V, current (state 1): >= 2.5 mA, voltage (state 0): <= 5 V, current (state 0): <= 1 mA
Configurable filtering time	0 ms no filter (none) 0.004...0.04 ms bounce filter (latch/event and cumulative filter by step Nx0.5ms (64>=N>=2)) 3...12 ms integrator (none/run/stop)
Input frequency	100 kHz for fast input (encoder mode) - control type A/B 100 kHz for fast input - control type single phase 100 kHz for fast input - control type pulse/direction
Cable distance between devices	Shielded cable: 10 m for fast input Shielded cable: 100 m for digital input Unshielded cable: 50 m for digital input
Connection pitch	3.5 mm
Overvoltage protection	With
Isolation between channels and internal logic	500 V DC

Isolation between channels	None
Discrete output number	2 fast output (normal mode), output logic: source 6 digital output, output logic: source
Discrete output voltage	24 V DC (voltage limit: 19.2...28.8 V) with transistor discrete output(s) 24 V DC (voltage limit: 5...30 V) with relay discrete output(s) 220 V AC (voltage limit: 100...250 V) with relay discrete output(s)
Input/Output number	2 for fast input, terminal(s): FI0...FI1 2 for fast output, terminal(s): FQ0...FQ1 6 for digital input, terminal(s): DI0...DI5 6 for digital output, terminal(s): DQ0...DQ5
Discrete output current	300 mA, response time 2 ms for fast output (normal mode) 50 mA, response time 2 ms for fast output (PWM or PTO mode) 2 A (current per output common:4 A), response time 5 ms with opening contact for digital output 2 A (current per output common:4 A), response time 2 ms with closing contact for digital output
Insulation resistance	> 10 MOhm between the I/O and internal logic > 10 MOhm between power supply and earth
Output frequency	<= 100 kHz for fast output (PTO mode) <= 1 kHz for fast output (PWM mode)
Absolute accuracy error	+/- 0.1 % of full scale of cyclic ratio 1...99% for fast output (PWM or PTO mode) 1 % of full scale of cyclic ratio 1...99% for fast output (PWM or PTO mode) +/- 5 % of full scale of cyclic ratio 10...90% for fast output (PWM or PTO mode) +/- 10 % of full scale of cyclic ratio 20...80% for fast output (PWM or PTO mode) +/- 15 % of full scale of cyclic ratio 30...70% for fast output (PWM or PTO mode)
Analogue input number	2 for analog input 2 for RTDs
Analogue input range	0...20 mA/4...20 mA - resolution: 12 bits, input impedance: 250 Ohm (tolerance: +/- 1 %) -10...+10 V or 0...10 V - resolution: 12 bits + sign, input impedance: >= 1 MOhm
Analogue input type	RTD at - 200...600 °C - resolution: 16 bits temperature probe: Pt 100/Pt 1000 RTD at - 50...200 °C - resolution: 16 bits temperature probe: Ni 100/Ni 1000 RTD at - 200...760 °C - resolution: 16 bits (thermocouple J) RTD at - 240...1370 °C - resolution: 16 bits (thermocouple K) RTD at 0...1600 °C - resolution: 16 bits (thermocouple R) RTD at 200...1800 °C - resolution: 16 bits (thermocouple B) RTD at 0...1600 °C - resolution: 16 bits (thermocouple S) RTD at - 200...400 °C - resolution: 16 bits (thermocouple T) RTD at - 200...900 °C - resolution: 16 bits (thermocouple E) RTD at - 200...1300 °C - resolution: 16 bits (thermocouple N)
Analogue output number	2 resistive load for 12 bits + sign
Analogue output range	0...20 mA/4...20 mA (> 300 Ohm) for open-circuit -10...10 V/0...10 V (> 2 kOhm) for short-circuit
Height	74.95 mm
Width	128 mm
Depth	102 mm
Product weight	0.551 kg

Environment

Standards	EN 61131-2 FCC Class A IEC 61000-6-2 RoHS compliant UL 508 ANSI/ISA 12-12-01 WEEE directive 2002/96/EC CSA C22.2 No 213 Class I Division 2 RoHS China SJ/T 11363-2006
Product certifications	C-Tick CULus 508 GOST CUL 1604 Class 1 Division 2 KCC CULus CSA 22-2 No 142
Marking	CE
Ambient air temperature for operation	0...50 °C
Ambient air temperature for storage	-20...60 °C
Relative humidity	5...85 % without condensation

Operating altitude	<= 2000 m
Storage altitude	0...10000 m
Maximum pressure	800...1114 hPa
IP degree of protection	IP65 for front panel conforming to IEC 60529 IP20 for rear panel conforming to IEC 60529
NEMA degree of protection	NEMA 4X for front panel
Pollution degree	2 conforming to IEC 60664
Environmental characteristic	Corrosive gas free

Offer Sustainability

Sustainable offer status	Green Premium product
RoHS (date code: YYWW)	Compliant - since 0844 - Schneider Electric declaration of conformity Schneider Electric declaration of conformity
REACH	Reference not containing SVHC above the threshold Reference not containing SVHC above the threshold
Product environmental profile	Available
Product end of life instructions	Available

Dimensions

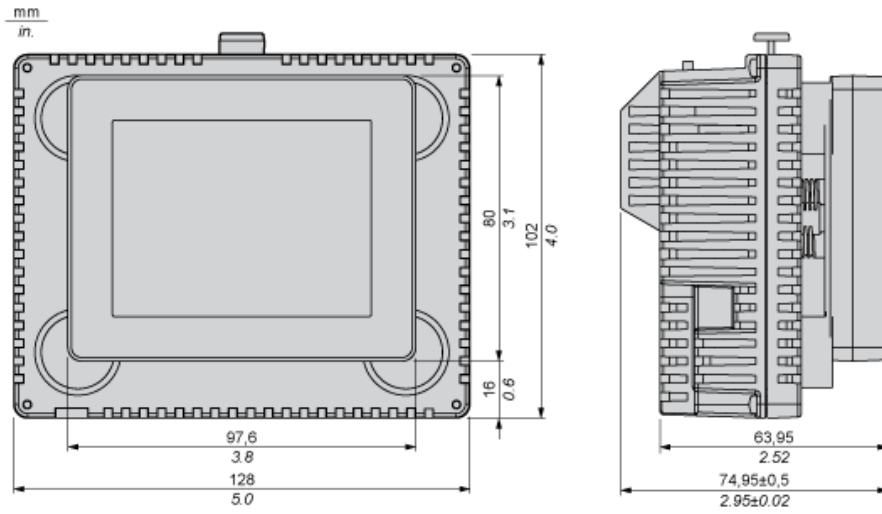

Recommended Mounting position

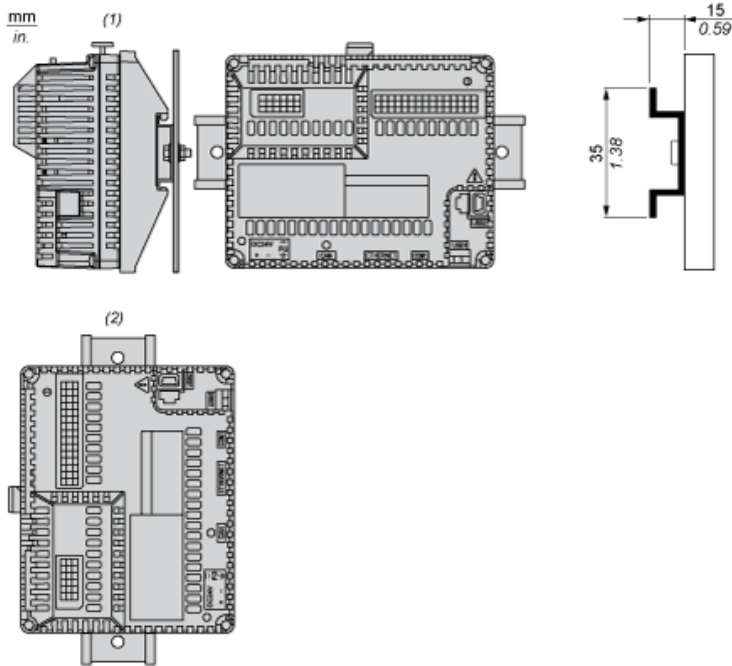

- (1) Horizontal mounting
- (2) Vertical mounting

No Recommended Mounting Position

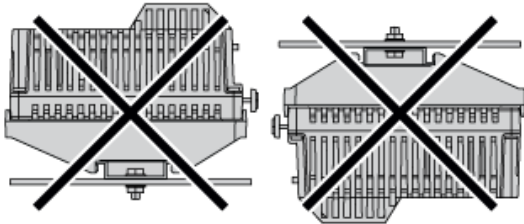

Clearance

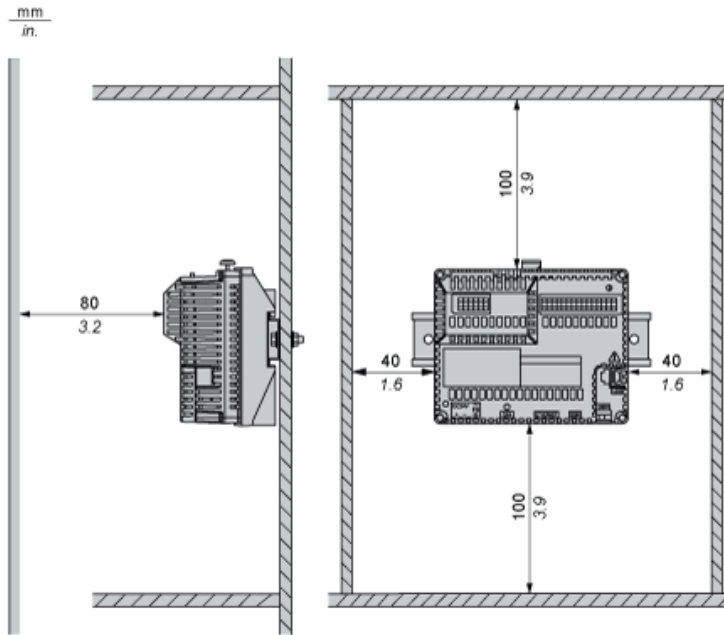

Keep adequate spacing for proper ventilation to maintain an ambient temperature between 0...50 °C (32...122 °F) for horizontal installation and 0...40 °C (32...104 °F) for vertical installation.

Wiring Diagram

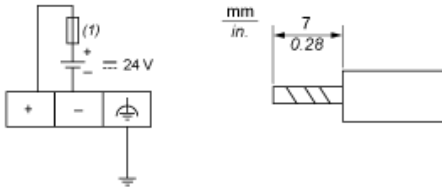

(1) Slow-blow 2A type T fuse

Wiring Diagram of the Analog Inputs and Analog Outputs

Voltage for Analog Inputs

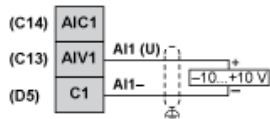
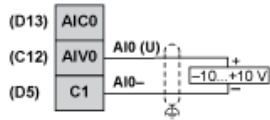

Current for Analog Inputs

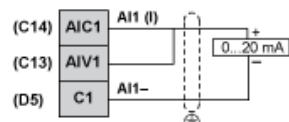
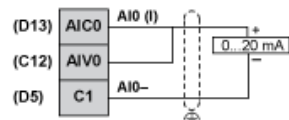

Voltage and Current for Analog Outputs

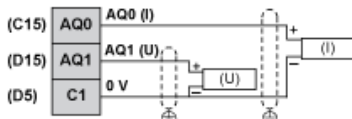

3 Wiring for Analog Inputs PT100

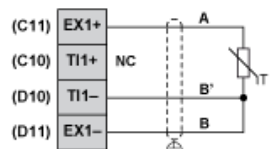
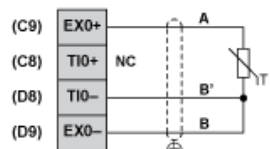

2 Wiring for Analog Inputs PT100

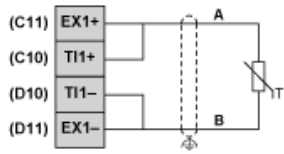
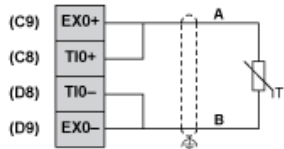

Thermocouple

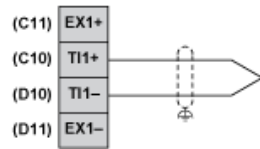
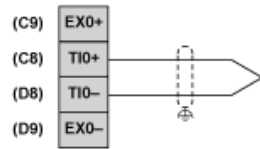

Wiring Diagram of Digital Inputs

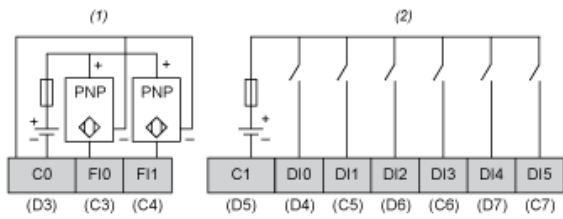

- (1) HSC inputs with pin assignment of terminal blocks C,D.
- (2) Digital inputs with pin assignment of terminal blocks C,D.

Wiring Diagram of Digital Outputs

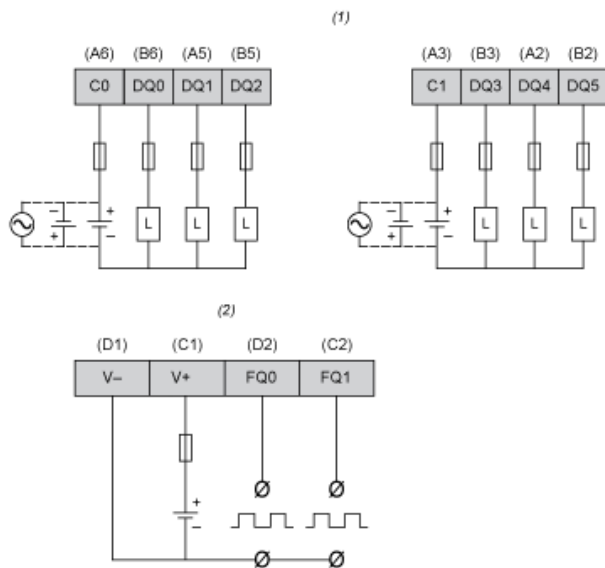

- (1) Digital outputs with pin assignment of terminal blocks A,B.
- (2) PWM outputs with pin assignment of terminal blocks C,D.