



## Main

Range of product	OsiSense XC
Series name	Special format
Product or component type	Limit switch
Product specific application	For hoisting and mechanical handling applications
Device short name	XCKMR
Body type	Fixed
Head type	Reversed rotary head
Material	Metal
Body material	Zamak
Head material	Zamak
Fixing mode	By the body
Movement of operating head	Rotary
Type of operator	Stay put crossed rods lever metal (square rod 6 mm, L = 200 mm)
Type of approach	Lateral approach 2 directions
Cable entry	3 entries tapped for M20 x 1.5 cable gland, cable outer diameter: 7...13 mm
Number of poles	4
Contacts type and composition	2 x (2 NC)
Contact operation	Slow-break, staggered

## Complementary

Switch actuation	By any moving part
Electrical connection	Screw-clamp terminals, clamping capacity: 1 x 0.5...2 x 2.5 mm <sup>2</sup>
Contacts insulation form	Zb
Number of steps	5 electrical positions
Contact block per direction [control circuit]	1 per direction
Positive opening	With

Disclaimer: This documentation is not intended as a substitute for and is not to be used for determining suitability or reliability of these products for specific user applications

Positive opening minimum torque	0.75 N.m
Minimum torque for tripping	0.5 N.m
Minimum actuation speed	6 m/min
Maximum actuation speed	1.5 m/s actuation point on the rod between 65 and 95 mm
Maximum displacement angle	180 ° -180 °
Contact code designation	A300, AC-15 (Ue = 240 V, Ie = 3 A) , Ithe = 10 A conforming to EN/IEC 60947-5-1 appendix A Q150, DC-13 (Ue = 125 V, Ie = 0.55 A) conforming to EN/IEC 60947-5-1 appendix A
[Ui] rated insulation voltage	300 V conforming to CSA C22.2 No 14 300 V conforming to UL 508 500 V degree of pollution 3 conforming to EN/IEC 60947-1
Resistance across terminals	<= 25 MOhm conforming to IEC 60255-7 category 3
[Uimp] rated impulse withstand voltage	6 kV conforming to EN/IEC 60947-1 6 kV conforming to IEC 60664
Short-circuit protection	10 A by gG cartridge fuse
Mechanical durability	2000000 cycles
Width	200 mm
Height	118 mm
Depth	59 mm
Product weight	0.55 kg
Terminals description ISO n°1	(11-12)NC (21-22)NC

## Environment

Shock resistance	50 gn conforming to EN/IEC 60068-2-27
Vibration resistance	25 gn (f = 10...500 Hz) conforming to EN/IEC 60068-2-6
IP degree of protection	IP66 conforming to EN/IEC 60529
IK degree of protection	IK07 conforming to EN 50102
Electrical shock protection class	Class I conforming to IEC 60536
Ambient air temperature for operation	-25...70 °C
Ambient air temperature for storage	-40...85 °C
Protective treatment	TC
Product certifications	CCC CE CSA UL
Standards	EN/IEC 60947-5-1 UL 508 CSA C22.2 No 14

## Offer Sustainability

Sustainable offer status	Green Premium product
RoHS (date code: YYWW)	Compliant - since 0936 - Schneider Electric declaration of conformity <a href="#">Schneider Electric declaration of conformity</a>
REACH	Reference not containing SVHC above the threshold <a href="#">Reference not containing SVHC above the threshold</a>
Product end of life instructions	Need no specific recycling operations

## Contractual warranty

Warranty period	18 months
-----------------	-----------

Dimensions

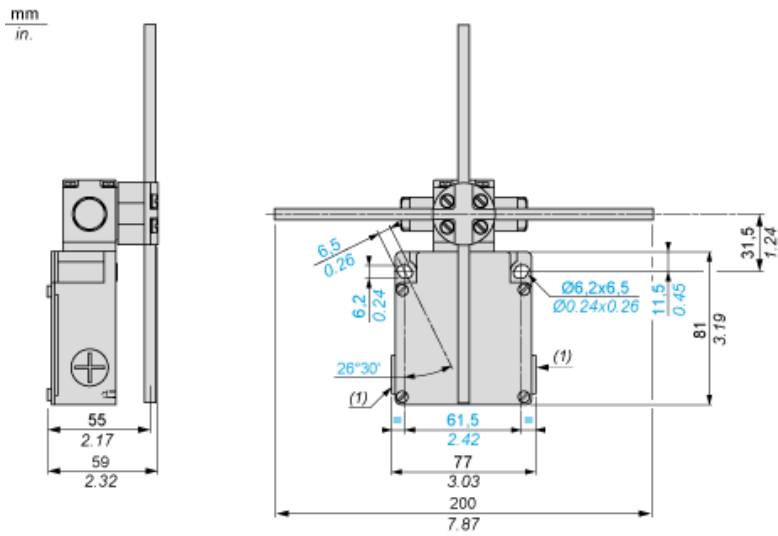

- (1) 3 tapped entries ISO M20x1.5  
 Ø : 2 elongated holes 6.2 x 6.5, inclined at 26°30' to the vertical axis, for M5 screws.

---

Wiring Diagram

---

2 x 2-pole NC+NC Break Before Make, Slow Break (Non Interchangeable Contacts)

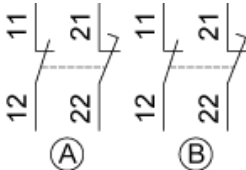

Functionnal Diagram

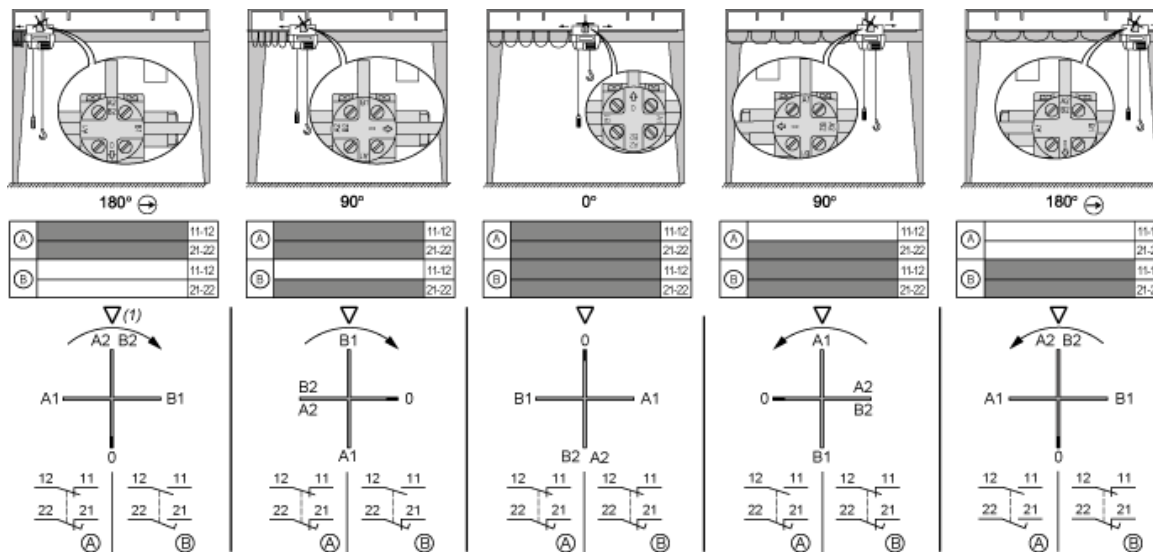

(1) Triangle symbol marked on top of head.