



Evaluation Board: Wide Vin Synchronous Buck DC/DC Converter with Integrated FET

BD9V101MUF-EVK-001 (5.0V | 1.0A Output)

User's Guide

<High Voltage Safety Precautions>

◇ Read all safety precautions before use

Please note that this document covers only the BD9V101MUF-LB evaluation board (BD9V101MUF-EVK-001) and its functions. For additional information, please refer to the datasheet.

To ensure safe operation, please carefully read all precautions before handling the evaluation board



Depending on the configuration of the board and voltages used,

Potentially lethal voltages may be generated.

Therefore, please make sure to read and observe all safety precautions described in the red box below.

Before Use

- [1] Verify that the parts/components are not damaged or missing (i.e. due to the drops).
- [2] Check that there are no conductive foreign objects on the board.
- [3] Be careful when performing soldering on the module and/or evaluation board to ensure that solder splash does not occur.
- [4] Check that there is no condensation or water droplets on the circuit board.

During Use

- [5] Be careful to not allow conductive objects to come into contact with the board.
- [6] **Brief accidental contact or even bringing your hand close to the board may result in discharge and lead to severe injury or death.**

Therefore, DO NOT touch the board with your bare hands or bring them too close to the board.

In addition, as mentioned above please exercise extreme caution when using conductive tools such as tweezers and screwdrivers.

- [7] If used under conditions beyond its rated voltage, it may cause defects such as short-circuit or, depending on the circumstances, explosion or other permanent damages.
- [8] Be sure to wear insulated gloves when handling is required during operation.

After Use

- [9] The ROHM Evaluation Board contains the circuits which store the high voltage. Since it stores the charges even after the connected power circuits are cut, please discharge the electricity after using it, and please deal with it after confirming such electric discharge.
- [10] Protect against electric shocks by wearing insulated gloves when handling.

This evaluation board is intended for use only in research and development facilities and should be handled **only by qualified personnel familiar with all safety and operating procedures.**

We recommend carrying out operation in a safe environment that includes the use of high voltage signage at all entrances, safety interlocks, and protective glasses.

ROHM Switching Regulator Solutions

Evaluation Board: Wide Vin Synchronous Buck DC/DC Converter with Integrated FET

Introduction

This application note will provide the steps necessary to operate and evaluate ROHM's synchronous buck DC/DC converter using the BD9V101MUF-EVK-001 evaluation board. Component selection, operating procedures, and application data are included.

Description

BD9V101MUF-LB is a current mode synchronous buck converter that uses high voltage rated POWER MOSFETs. It features a wide range input voltage range of 16V to 60V and utilizes a very short minimum pulse width (down to 20ns) which enables direct conversion from 60V power supply to 3.3V at 2.1MHz operation. Additionally, this product is part of the *LB family line of products, which means ROHM guarantees long lifetime support of this product specifically for industrial market applications.

Applications

- Industrial Equipment
- Consumer Supplies

Evaluation Board Operating Limits and Absolute Maximum Ratings

Parameter	Symbol	Limit			Unit	Conditions
		MIN	TYP	MAX		
Supply Voltage (Absolute Maximum Ratings)						
	BD9V101MUF	V_{IN}	-0.3	-	70	V
Supply Voltage (Recommended Operating Conditions)						
	BD9V101MUF	V_{IN}	16		60	V
Output Voltage / Current						
	BD9V101MUF-EVK-001	V_{OUT}	-	5.0	-	V
		I_{OUT}	-	-	1.0	A

Evaluation Board

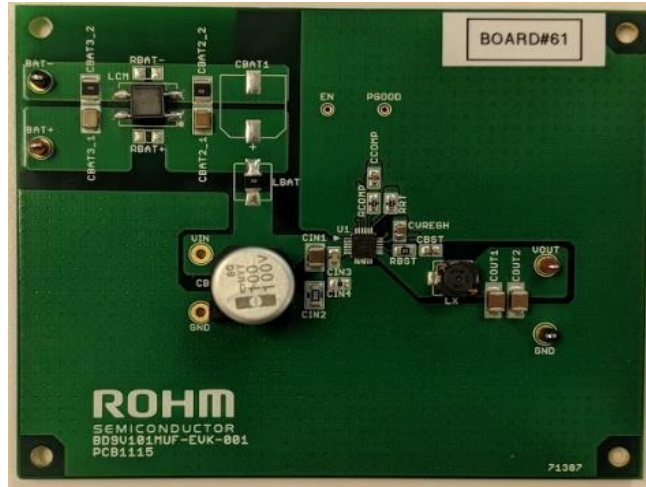

Fig 1: BD9V101MUF-EVK-001 Evaluation Board

Evaluation Board Schematic

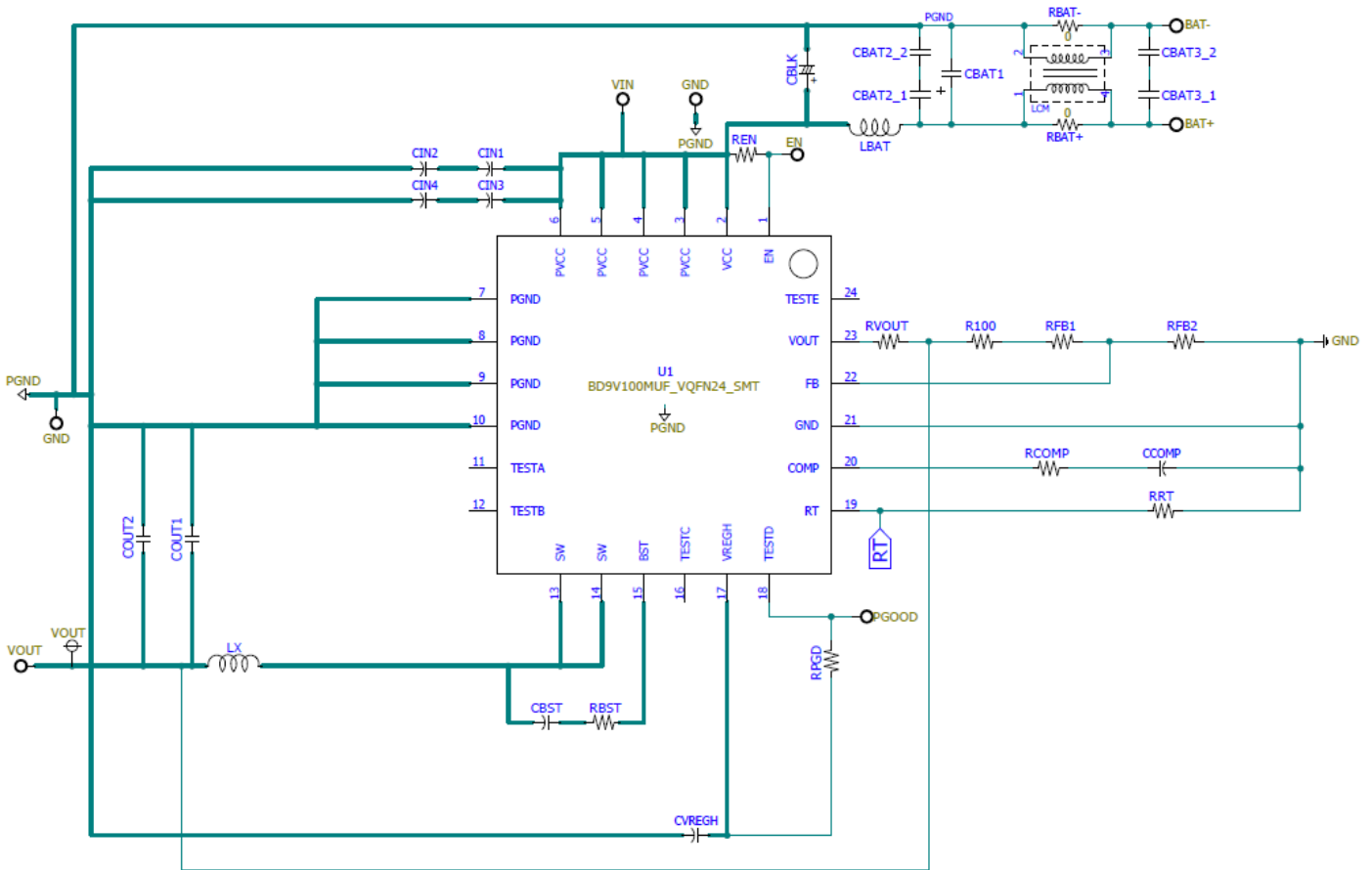

Fig 2: BU33UV7NUX Evaluation Board Schematic

Evaluation Reference Application Circuit

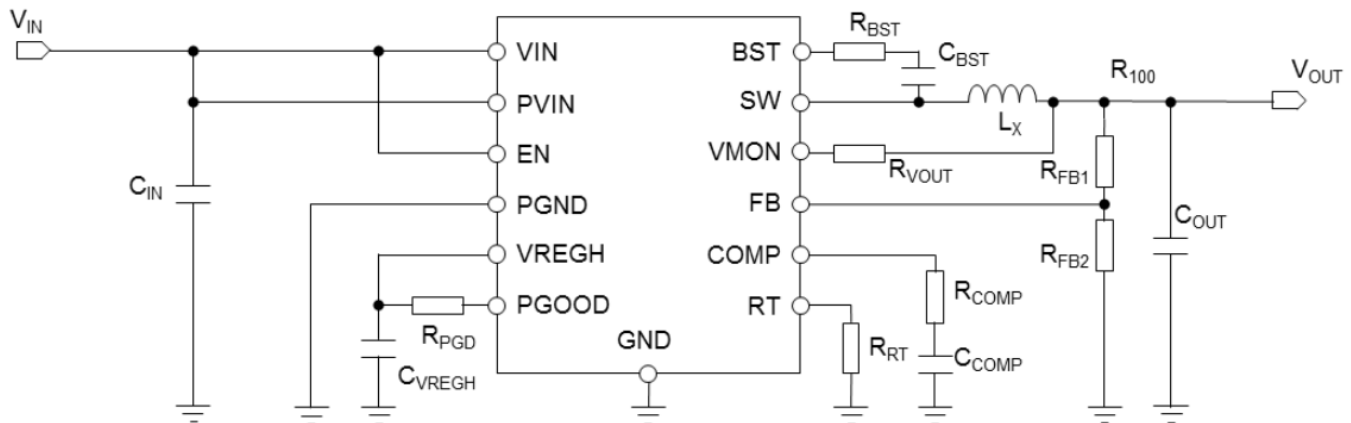

Fig 3: BD9V101MUF Reference Application Circuit

Special Evaluation Board Notes

Note that this EVK uses some additional components when compared against the reference application circuit (primarily the additional filter and capacitors on the input side). These were added to this EVK to pass the CISPR22 radiated emissions test. If this is not a concern for your application, these external components may be omitted from your final design to required board space and external components.

Evaluation Board Operating Procedure

1. This EVK does not have any switches or settings to configure. So, to operate, user just needs to apply the input voltage (between 16 and 60V) to the BAT+ and BAT- terminals of the board.
2. NOTE: Do not hot plug a power supply to this device. This can cause overshoot spikes to the input side of the board and the over voltage could potentially destroy some components
3. There is an enable pin available on this IC; however, it is connected to Vin using the REN resistor jumper. If you want to test with an MCU or other control signal, please note that high level voltage will turn the device on (>2.5V) and low level voltage will turn the device off (<0.8V)

Reference Application Data

For additional device performance graphs, please refer to the IC's datasheet at the following link:

http://rohmfs.rohm.com/en/products/databook/datasheet/ic/power/switching_regulator/bd9v101muf-1b-e.pdf

Evaluation Board BOM

Below is a table showing the Bill of Materials. Part numbers and suppliers are included.

Item	Qty	Reference	Part	Description	Manufacturer	MFG1_PART#
1	2	BAT- (PGND3), GND (TP12)	Black TP	TEST POINT PC MINI .040"D BLACK	Keystone Electronics	5001
2	2	BAT+ (BAT), VOUT (TP5)	RED TP	TEST POINT PC MINI .040"D RED	Keystone Electronics	5000
3	1	CBAT1	DNP	N/A	DNP	DNP
4	1	CBAT2_1	GCM32DC72A475KE02L	CAP CER 4.7UF 100V X7S 1210	MURATA	GCM32DC72A475KE02L
5	1	CBAT3_1	GRM32QR73A682KW01L	CAP CER 6800PF 1KV X7R 1210	MURATA	GRM32QR73A682KW01L
6	3	CBAT3_2, CBAT2_2	SHORT	RES SMD 0 OHM JUMPER 1/4W 1206	YAGEO	AC1210JR-070RL
7	1	CBLK	EMVY101ARA101MKE0S	CAP ALUM 100UF 20% 100V SMD	United Chemi-Con	EMVY101ARA101MKE0S
8	1	CBST	GCM188R71H223K	0603 0.022uF 50volts X7R +/-10%	MURATA	GCM188R71H223K
9	1	CCOMP	GCM188R71H102K	0603 1000pF 50volts X7R 10%	MURATA	GCM188R71H102K
10	1	CIN1	UMK325B7475MMHT	1210 4.7uF 50volts X7R 10%	TAIYO YUDEN	UMK325B7475MMHT
11	1	CIN2	SHORT	RES SMD 0 OHM JUMPER 1/4W 1206	PANASONIC	ERJ-8GEY0R00V
12	1	CIN3	GCM188R71H104K	0603 0.1uF 50volts X7R 10%	MURATA	
13	2	COUT1, COUT2	CGA6P1X7R1C226M250AC	1210 22uF 16volts X7R 10%	TDK	CGA6P1X7R1C226M250AC
14	1	CVREGH	GCM21BR71C225K	0805 2.2uF 16volts X7R 10%	MURATA	GCM21BR71C225K
15	1	LBAT	RC2010JK-070RL	Needs Short, 2010 sized	YAGEO	RC2010JK-070RL
16	1	LCM	PLT5BPH2014R4SNL	CMC 2.4A 2LN 200OHM SMD AEC-Q200	MURATA	PLT5BPH2014R4SNL
17	1	LX	4.7uH	FIXED IND 4.7UH 3.3A 30 MOHM SMD	TDK	CLF6045NIT-4R7N-D
18	3	R100, REN, CIN4	0, SHORT	JUMPER 5% 1/10W 0603	ROHM	TRR03EJPJ000
19	2	RBAT+, RBAT-	DNP	N/A	DNP	DNP
20	1	RBST	3.3	3.3 OHM 5% 1/8W 0805	ROHM	MCR10ERTJ3R3
21	1	RCOMP	51k	51k OHM 0.5% 0.1W 0603	PANASONIC	ERJ-PB3D5102V
22	1	RFB1	43k	43k OHM 0.5% 0.1W 0603	SUSUMU	RR0816P-433-D
23	1	RFB2	8.2k	8.2k OHM 0.5% 0.1W 0603	PANASONIC	ERJ-PB3D8201V
24	1	RPGD	100k	100k OHM 0.5% 0.1W 0603	PANASONIC	ERJ-PB3D1003V
25	1	RRT	7.5k	7.5k OHM 0.5% 0.1W 0603	PANASONIC	ERJ-PB3D7501V
26	1	RVOUT	2k	2k OHM 0.5% 0.1W 0603	ROHM	ERJ-PB3D2001V
27	1	U1	BD9V101MUF	Buck Converter	ROHM	BD9V101MUF-LBE2

Fig 4: BD9V101MUF-EVK-001 EVK BOM

Evaluation Board Layout Information

- Material: FR-4
- Board Thickness: 1.6mm
- Copper Thickness: 1oz
- Board Size: 80mm x 100mm
- Minimum Copper Width: 0.15mm
- Minimum Air Gap: 0.15mm
- Minimum Hold Gap: 0.3mm



TOP VIEW

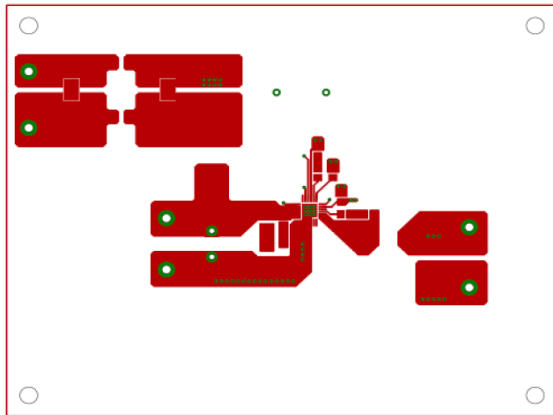

TOP LAYER

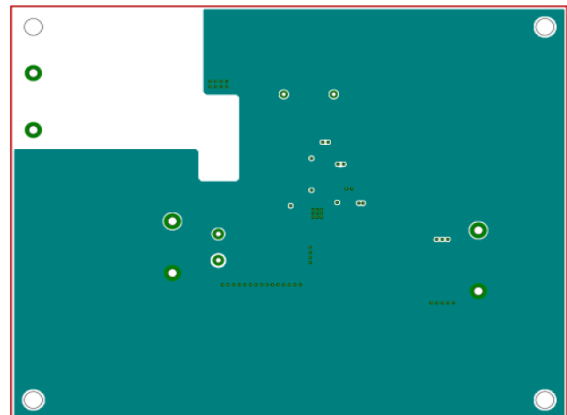

2nd LAYER

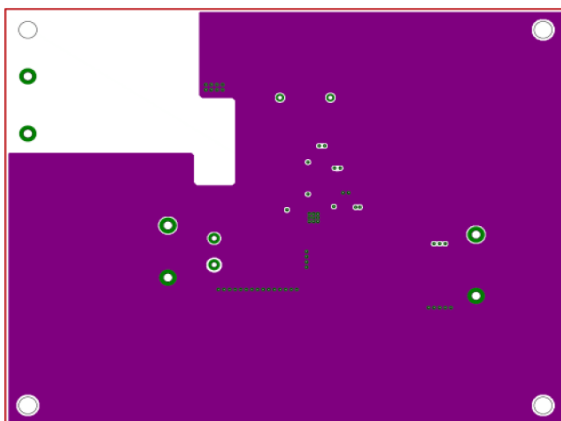

3rd LAYER

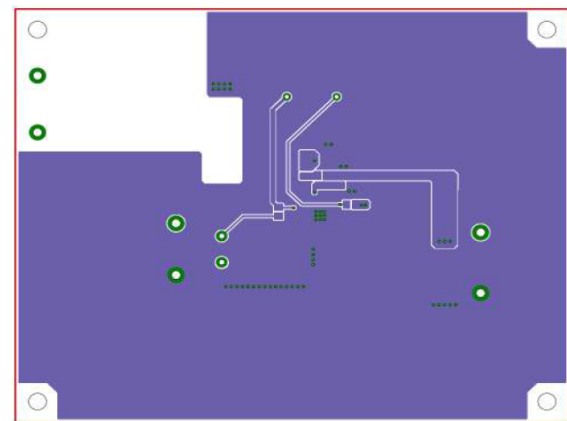

BOTTOM LAYER

Notes

- 1) The information contained herein is subject to change without notice.
- 2) Before you use our Products, please contact our sales representative and verify the latest specifications :
- 3) Although ROHM is continuously working to improve product reliability and quality, semiconductors can break down and malfunction due to various factors.
Therefore, in order to prevent personal injury or fire arising from failure, please take safety measures such as complying with the derating characteristics, implementing redundant and fire prevention designs, and utilizing backups and fail-safe procedures. ROHM shall have no responsibility for any damages arising out of the use of our Products beyond the rating specified by ROHM.
- 4) Examples of application circuits, circuit constants and any other information contained herein are provided only to illustrate the standard usage and operations of the Products. The peripheral conditions must be taken into account when designing circuits for mass production.
- 5) The technical information specified herein is intended only to show the typical functions of and examples of application circuits for the Products. ROHM does not grant you, explicitly or implicitly, any license to use or exercise intellectual property or other rights held by ROHM or any other parties. ROHM shall have no responsibility whatsoever for any dispute arising out of the use of such technical information.
- 6) The Products specified in this document are not designed to be radiation tolerant.
- 7) For use of our Products in applications requiring a high degree of reliability (as exemplified below), please contact and consult with a ROHM representative : transportation equipment (i.e. cars, ships, trains), primary communication equipment, traffic lights, fire/crime prevention, safety equipment, medical systems, servers, solar cells, and power transmission systems.
- 8) Do not use our Products in applications requiring extremely high reliability, such as aerospace equipment, nuclear power control systems, and submarine repeaters.
- 9) ROHM shall have no responsibility for any damages or injury arising from non-compliance with the recommended usage conditions and specifications contained herein.
- 10) ROHM has used reasonable care to ensure the accuracy of the information contained in this document. However, ROHM does not warrants that such information is error-free, and ROHM shall have no responsibility for any damages arising from any inaccuracy or misprint of such information.
- 11) Please use the Products in accordance with any applicable environmental laws and regulations, such as the RoHS Directive. For more details, including RoHS compatibility, please contact a ROHM sales office. ROHM shall have no responsibility for any damages or losses resulting non-compliance with any applicable laws or regulations.
- 12) When providing our Products and technologies contained in this document to other countries, you must abide by the procedures and provisions stipulated in all applicable export laws and regulations, including without limitation the US Export Administration Regulations and the Foreign Exchange and Foreign Trade Act.
- 13) This document, in part or in whole, may not be reprinted or reproduced without prior consent of ROHM.



Thank you for your accessing to ROHM product informations.
More detail product informations and catalogs are available, please contact us.

ROHM Customer Support System

<http://www.rohm.com/contact/>