

Surface Mount Aluminum Electrolytic Capacitors NACV Series

FEATURES

- CYLINDRICAL V-CHIP CONSTRUCTION FOR SURFACE MOUNT
- HIGH VOLTAGE (160VDC AND 400VDC)
- 8 x10.8mm ~ 16 x17mm CASE SIZES
- LONG LIFE (2000 HOURS AT +105°C)
- DESIGNED FOR REFLOW SOLDERING
- **MEETS THE REQUIREMENTS OF AEC-Q200***

*Contact NIC for supporting test data

CHARACTERISTICS

Rated Voltage Range		160	200	250	400
Rated Capacitance Range		10 ~ 82	10 ~ 68	3.3 ~ 47	2.2 ~ 22
Operating Temperature Range		-40 ~ +105°C			
Capacitance Tolerance		±20% (M)			
Max. Leakage Current After 2 Minutes	C ≤ 1000μF	0.03CV + 15μA			
	C > 1000μF	0.02CV + 25μA			
Max. Tanδ @ 120Hz		0.20	0.20	0.20	0.25
Low Temperature Stability (Impedance Ratio @ 120Hz)	Z-25°C/Z+20°C	3	3	3	6
	Z-40°C/Z+20°C	6	6	6	10
High Temperature Load Life at 105°C 2,000 hrs φD > 10mm 1,000 hrs φD = 8mm	Capacitance Change	Within ±25% of initial measured value			
	Tan δ	Less than 200% of specified value			
	Leakage Current	Less than the specified value			

**RoHS
Compliant**
includes all homogeneous materials

*See Part Number System for Details

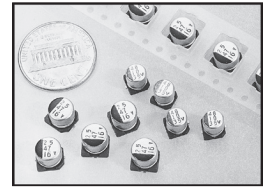

STANDARD PRODUCTS AND CASE SIZES (mm)

Cap. (μF)	Code	Working Voltage			
		160	200	250	400
2.2	2R2	-	-	-	8x10.8
3.3	3R3	-	-	8x10.8	10x10.8
4.7	4R7	-	-	8x10.8	10x10.8
6.8	6R8	-	-	8x10.8	12.5x14
10	100	8x10.8	10x10.8	10x10.8	12.5x14
22	220	12.5x14	12.5x14	12.5x14	16x17
33	330	12.5x14	12.5x14	16x17	-
47	470	16x17	16x17	16x17	-
68	680	16x17	16x17	-	-
82	820	16x17	-	-	-

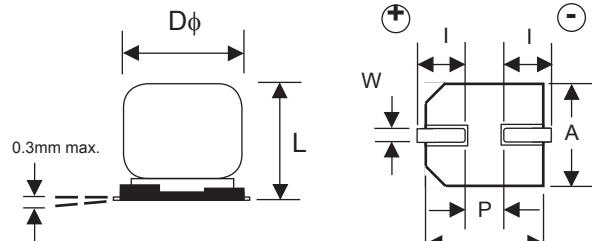

For Automotive Equipment, see part numbering system

DIMENSIONS (mm)

Case Size	Dφ±0.5	L max.	A±0.2	B±0.2	I±0.2	W	P±0.2
8x10.8	8.0	10.8	8.3	8.3	2.9	0.7~1.1	3.2
10x10.8	10.0	10.8	10.3	10.3	3.2	0.7~1.4	4.6
12.5x14	12.5	14.0	12.8	12.8	4.5	1.0~1.4	4.6
16x17	16.0	17.0	16.3	16.3	5.0	1.7~2.1	7.0

Case Diameter	Termination Material
8 ~ 12.5mm φ	97% Sn, 3% Bi
16mm	100% Sn

PART NUMBER SYSTEM

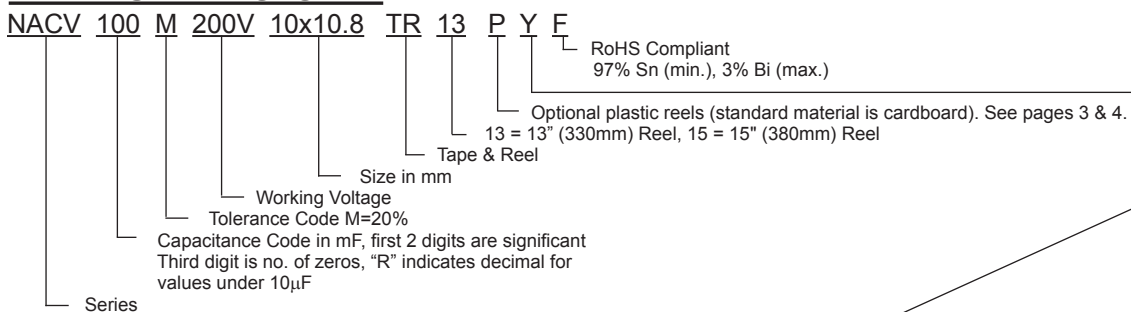

Optional: Suitable for automotive equipment, sourced to special production and inspection at TS-16949 certified production site

PRECAUTIONS

Please review the notes on correct use, safety and precautions found at <https://www.niccomp.com/resource/files/aluminum/AlumApplInfoCautions.pdf>
If in doubt or uncertainty, please review your specific application - process details with NIC's technical support personnel: tpmg@niccomp.com



Surface Mount Aluminum Electrolytic Capacitors NACV Series

STANDARD VALUES, CASE SIZES AND SPECIFICATIONS

NIC Part Number	Cap. (μF)	W.V. (Vdc)	Dissipation Factor (Tan δ)	Max. Ripple Current (mA) +105°C/120Hz	Max. ESR (Ω) +20°C/120Hz	Load Life Hours @ +105°C
NACV100M160V8x10.8TR13F	10	160	0.20	57	33.2	1,000
NACV220M160V12.5x14TR15F	22		0.20	112	15.1	2,000
NACV330M160V12.5x14TR15F	33		0.20	137	10.1	2,000
NACV470M160V16x17TR15F	47		0.20	180	7.1	2,000
NACV680M160V16x17TR15F	68		0.20	215	4.9	2,000
NACV820M160V16x17TR15F	82		0.20	235	4.0	2,000
NACV100M200V10x10.8TR13F	10	200	0.20	64	33.2	2,000
NACV220M200V12.5x14TR15F	22		0.20	112	15.1	2,000
NACV330M200V12.5x14TR15F	33		0.20	137	10.1	2,000
NACV470M200V16x17TR15F	47		0.20	180	7.1	2,000
NACV680M200V16x17TR15F	68		0.20	215	4.9	2,000
NACV3R3M250V8x10.8TR13F	3.3		250	0.20	31	100.5
NACV4R7M250V8x10.8TR13F	4.7	0.20		37	70.6	1,000
NACV6R8M250V8x10.8TR13F	6.8	0.20		44	48.8	1,000
NACV100M250V10x10.8TR13F	10	0.20		64	33.2	2,000
NACV220M250V12.5x14TR15F	22	0.20		112	15.1	2,000
NACV330M250V16x17TR15F	33	0.20		150	10.1	2,000
NACV470M250V16x17TR15F	47	0.20		180	7.1	2,000
NACV2R2M400V8x10.8TR13F	2.2	400		0.25	25	188.5
NACV3R3M400V10x10.8TR13F	3.3		0.25	36	125.7	2,000
NACV4R7M400V10x10.8TR13F	4.7		0.25	38	88.2	2,000
NACV6R8M400V12.5x14TR15F	6.8		0.25	47	61.0	2,000
NACV100M400V12.5x14TR15F	10		0.25	57	41.5	2,000
NACV220M400V16x17TR15F	22		0.25	115	18.8	2,000

For Automotive Equipment, see part number system

Review & Compare Reflow Soldering Heat Limits
 V-chip SMT Aluminum Electrolytic Capacitors
www.niccomp.com/RSL



Surface Mount Aluminum Electrolytic Capacitors NACV Series

CARRIER TAPE

Case Size	A ±0.2	B ±0.2	C ±0.3	D ±0.1	P ±0.1	T ±0.2
8 X 10.8	8.7	8.7	24.0	11.5	16.0	11.1
10 x 10.8	10.7	10.7	24.0	11.5	16.0	11.2
12.5 x 14	13.2	13.2	32.0	14.2	24.0	14.3
16 x 17	17.5	17.5	44.0	20.2	28.0	17.3

TR13 330mm (13") CARDBOARD REEL

TR15 380mm (15") CARDBOARD REEL

(See page 6 for plastic reel dimensions)

Case Size	W ±1	Quantity Per Reel	
		13" Reel	15" Reel
8 X 10.8	26.0*	300 pcs	N/A
10 x 10.8	26.0*	300 pcs	N/A
12.5 x 14	34.0	N/A	250 pcs
16 x 17	46.0	N/A	200 pcs

*W+3/-1

TAPING SPECIFICATIONS (mm)

1. Both Leader and Trailer tape: Minimum 40mm (1.57") empty carrier tape pockets.
2. Leader tape: Approximately 20cm of cover tape at leader.
3. Connection: Maximum 3 connections (slices) per reel.

CARRIER

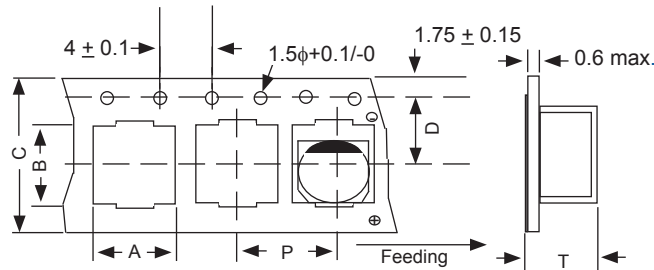

STANDARD REEL (CARDBOARD)

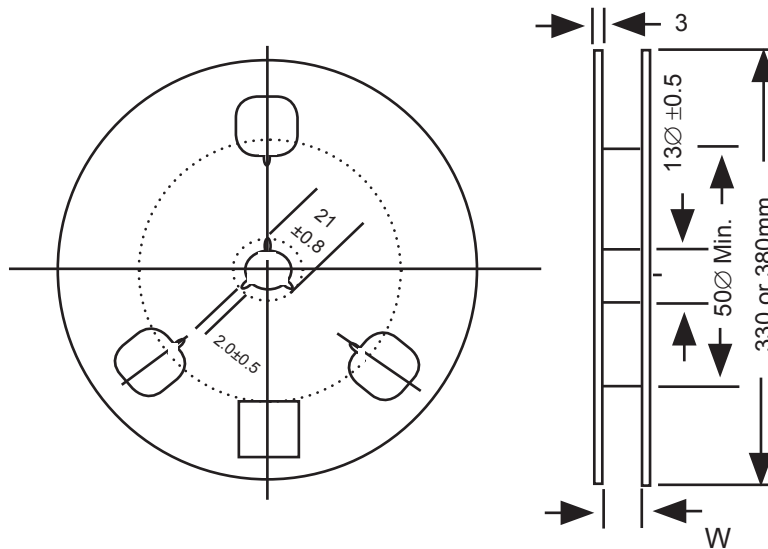

Surface Mount Aluminum Electrolytic Capacitors NACV Series

Optional V-Chip 330mm Plastic Reels (TR13P suffix)

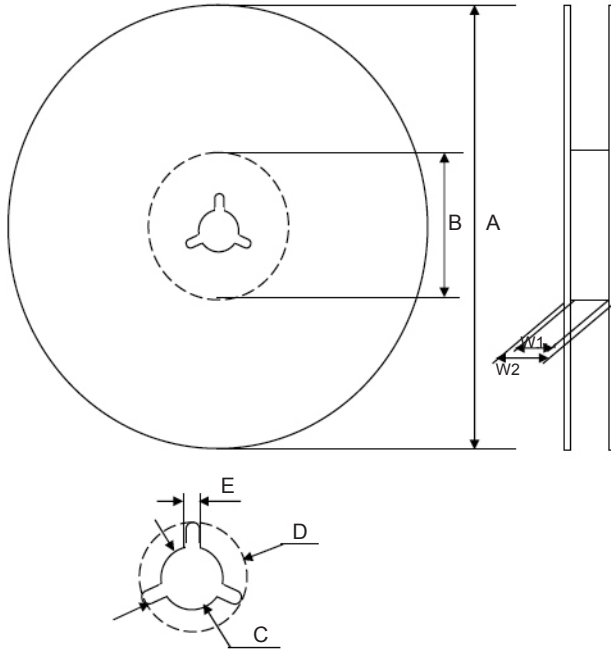

Dimensions (mm)

Case Size	Tape Width	W1	W2
8x10.8, 10x10.8	24.0	24.4 ~ 26.4	27.5 ~ 32.0

Case Size	Tape Width	A	B	C	D	E
8x10.8, 10x10.8	24.0	$\phi 330 \pm 2$	$\phi 50 \sim 105$	$\phi 13 \pm 0.5$	$\phi 21 \pm 1.0$	2.0 ± 0.5

Color
Black or Blue

Optional V-Chip 380mm Plastic Reels (TR15P suffix)

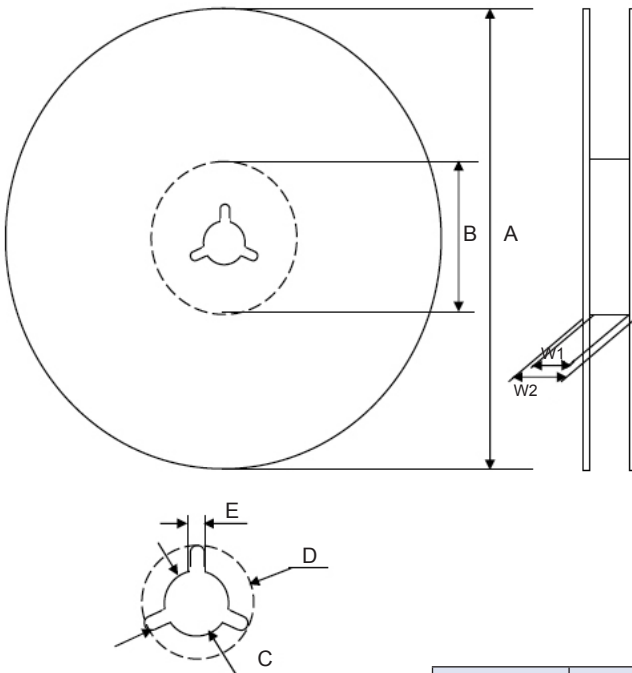

Dimensions (mm)

Case Size	Tape Width	W1	W2
12.5x14	32.0	33.0 ~ 34.0	36.5 ~ 38.5
16x17	44.0	45.0 ~ 46.0	48.5 ~ 50.5

Case Size	Tape Width	A	B	C	D	E
12.5x14	32.0	$\phi 380$	$\phi 80 \sim 105$	$\phi 13 \pm 0.5$	$\phi 21 \pm 1.0$	2.0 ± 0.5
16x17	44.0	± 2				

Color
Black or Blue

Case Size	Quantity Per Reel	
	13" Reel	15" Reel
8 X 10.8	300 pcs	N/A
10 x 10.8	300 pcs	N/A
12.5 x 14	N/A	250 pcs
16 x 17	N/A	200 pcs

