



Main

Range of product	Harmony XVM
Accessory / separate part designation	Ø 20 mm aluminium support tube with metal bracket
Accessory / separate part category	Mounting and fixing accessories
Accessory / separate part destination	Beacons and indicator banks Ø 45 mm

Complementary

Accessory / separate part type	Support tube with bracket
Product compatibility	XVM.
Colour	Aluminium
Height under base unit	263 mm
Length	250 mm
Product weight	0.242 kg

Contractual warranty

Warranty period	18 months
-----------------	-----------

Disclaimer: This documentation is not intended as a substitute for and is not to be used for determining suitability or reliability of these products for specific user applications.

Dimensions and Mounting

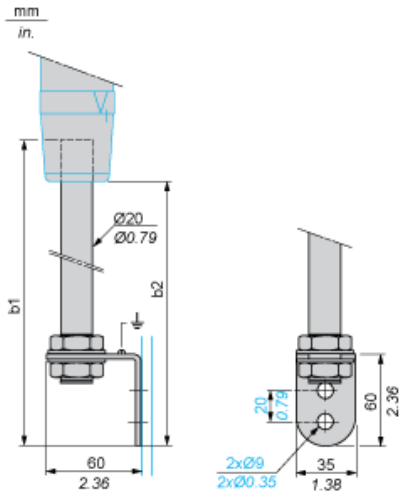

Support tube length		b1 (tube + plate)		b2 (height under base unit)	
mm	in.	mm	in.	mm	in.
250	9.84	283	11.14	256	10.08

Panel Cut-Out

