



DISSTON®

HOLE SAWS

BLU-MOL®

STANDARD TUNGSTEN CARBIDE TIPPED HOLE CUTTERS

Safety collar stop prevents over-cutting for safer and faster performance

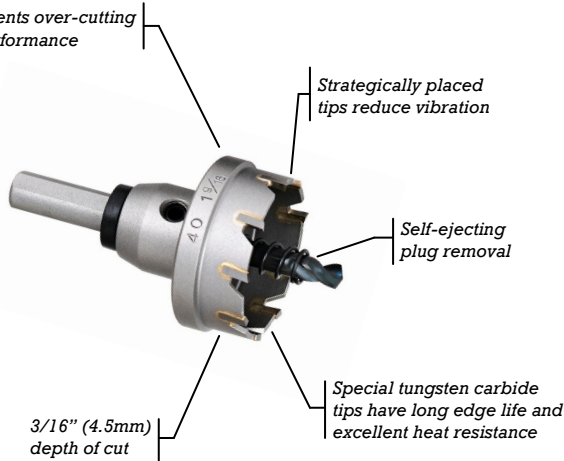

3/8" (10mm) chuck for sizes up to 2-1/2"

1/2" (13mm) chuck for sizes 2-9/16" and up

3/16" (4.5mm) depth of cut

Tungsten carbide tips have excellent wear and heat resistance. Light, smooth cutting entry with great boring speed. For cutting steels up to 3/16" (4.5mm) thick.

Standard Tungsten Carbide Hole Cutters (Clamshelled)

Application Information.

- For cutting stainless steel, steel, aluminium and cast iron up to 3/16" (4.5mm) thick.

Stock Code	Size	Individual Packaged Weight (kg)	Individual Packaged Dimensions (mm)	Individual Packaged Dimensions (mm)	Individual Packaged Dimensions (mm)	Barcode
D3165	16mm	0.103	85	26	26	035781023603
D3167	19mm	0.104	85	26	26	035781023627
D3206	20mm	0.105	85	26	26	035781025553
D3169	22mm	0.108	85	26	26	035781023641
D3171	25mm	0.113	85	28	28	035781023665
D3175	32mm	0.145	85	33	33	035781023702
D3179	38mm	0.164	85	39	39	035781023740
D3180	40mm	0.167	85	41	41	035781023757
D3187	51mm	0.213	85	53	53	035781023825

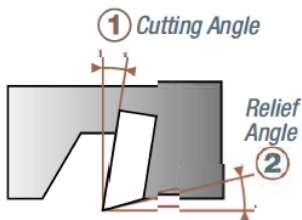

LIGHT AND SMOOTH CUTTING
The tungsten carbide tips are excellent in durability due to ideal blade angles based on the latest metal cutting technology.

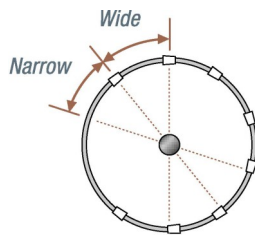

Variable tip placement reduces vibration.

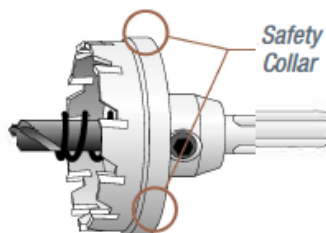

SAFE DESIGN
For both safety and prevention of damage to the material being cut, there is a safety collar, which acts as a stop. It prevents over-cutting and loss of control.

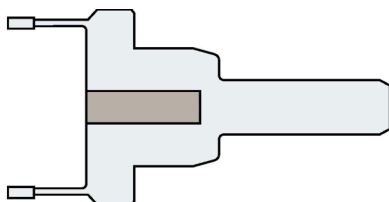

UNI-BODY CONSTRUCTION
The arbored hole cutter has solid construction that eliminates play between the shank and the body, resulting in sharp, crisp, smooth cutting.