

- Open frame 100 W power supply with JST connection in 2.0" x 3.0" package
- Certification according to IEC/EN/ES 60601-1 3rd edition for 2 x MOPP
- Low leakage current <75 µA rated for BF applications
- Risk management process according to ISO 14971 incl. risk management file
- Acceptance criteria for electronic assemblies acc. to IPC-A-610 Level 3
- Active power factor correction >0.95
- Protection class I and II prepared
- Operating up to 5000 m altitude
- Ready to meet ErP directive, <0.3 W no load power consumption
- 5 year product warranty



ES 60601-1 IEC 60601-1  
UL 60950-1 IEC 60950-1

The TPP 100A-J series of 100 Watt AC/DC open frame power supplies feature a reinforced double I/O isolation system according to latest medical safety standards (60601-1 3rd edition, 2 x MOPP). The earth leakage current is below 75 µA which makes the units suitable for BF (body floating) applications. The excellent efficiency of up to 92% allows a high power density for the standard 2.0" x 3.0" packaging format. The full load operating temperature range is -25°C to +55°C while it goes up to 80°C with 50% load derating. The EMC characteristic is dedicated for applications in industrial and medical fields. High reliability is provided by the use of industrial quality grade components and an excellent thermal management. It makes the products an ideal solution for medical devices and for demanding safety and space critical applications.

### Models

Order Code	Output Power max.	Output Voltage nom. (adjustable)	Output Current max.	Efficiency typ.
TPP 100-112A-J	100 W	12 VDC (10.8 - 13.2 VDC)	8'340 mA	91 %
TPP 100-115A-J		15 VDC (13.5 - 16.5 VDC)	6'670 mA	92 %
TPP 100-124A-J		24 VDC (21.6 - 26.4 VDC)	4'170 mA	92 %
TPP 100-128A-J		28 VDC (25.2 - 30.8 VDC)	3'580 mA	92 %
TPP 100-136A-J		36 VDC (32.4 - 39.6 VDC)	2'780 mA	91 %
TPP 100-148A-J		48 VDC (43.2 - 52.8 VDC)	2'090 mA	91 %

### Input Specifications

Input Voltage	- AC Range	85 - 264 VAC (Full Range)
	- DC Range	120 - 370 VDC (designed for, no certification)
Input Frequency		47 - 63 Hz
Input Current	- Full Load & Vin = 230 VAC	550 mA max.
	- Full Load & Vin = 115 VAC	1150 mA max.
Power Consumption	- at no Load	300 mW max. (Ready to meet ErP directive)
Input Inrush Current	- at 230 VAC	60 A max.
Power Factor		0.95 min. (Active Power Factor Correction)
Input Protection		T 3.15 A / 250 VAC (Internal Fuse in L & N)

### Output Specifications

Output Voltage Adjustment		±10% (by trim potentiometer)
Voltage Set Accuracy		±1% max.
Regulation	- Input Variation (Vmin - Vmax)	0.2% max.
	- Load Variation (0 - 100%)	0.5% max.
Ripple and Noise (20 MHz Bandwidth)	12 VDC model:	120 mVp-p typ. (with 10 µF X7R)
	15 VDC model:	150 mVp-p typ. (with 10 µF X7R)
	24 VDC model:	160 mVp-p typ. (with 1 µF X7R)
	28 VDC model:	180 mVp-p typ. (with 1 µF X7R)
	36 VDC model:	190 mVp-p typ. (with 1 µF X7R)
	48 VDC model:	340 mVp-p typ. (with 0.1 µF X7R)
Capacitive Load	12 VDC model:	6'950 µF max.
	15 VDC model:	4'450 µF max.
	24 VDC model:	1'750 µF max.
	28 VDC model:	1'280 µF max.
	36 VDC model:	770 µF max.
	48 VDC model:	430 µF max.
Minimum Load		not required
Temperature Coefficient		±0.02 %/K
Hold-up Time	- at 230 VAC	16 ms min.
	- at 115 VAC	16 ms min.
Start-up Time	- at 230 VAC	1'000 ms max.
	- at 115 VAC	1'000 ms max.
Output Current Limitation		115 - 150% of Iout max.
Short Circuit Protection		Continuous, automatic recovery
Overvoltage Protection		115 - 135% of Vout nom.
Transient Response	- Response Deviation	3% max. (50% to 75% Load Step)
	- Response Time	500 µs typ. (50% to 75% Load Step)

### Safety Specifications

Safety Standards	- IT / Multimedia Equipment	IEC 60950-1 EN 60950-1 UL 60950-1
	- Medical Equipment	EN 60601-1 IEC 60601-1 ANSI/AAMI ES 60601-1
	- Certification Documents	2 x MOPP (Means Of Patient Protection) <a href="http://www.tracopower.com/overview/tpp100a-j">www.tracopower.com/overview/tpp100a-j</a>
Protection Class		Class I Prepared: Connection to PE Class II Prepared: Reinforced Insulation
Pollution Degree		PD 2: Office or Laboratory Environments
Over Voltage Category		OVC II

All specifications valid at nominal input voltage, full load and +25°C after warm-up time unless otherwise stated.

## EMC Specifications

<b>EMC Emission</b>		EN 60601-1-2 edition 4 (Medical Devices)
- Conducted Emissions		EN 55011 class B (internal filter) EN 55032 class B (internal filter) FCC Part 15, class B FCC Part 18, class B
- Radiated Emissions		EN 55011 class A (internal filter) EN 55032 class A (internal filter) FCC Part 15, class A FCC Part 18, class A
- Harmonic Current Emissions		EN 61000-3-2, class A EN 61000-3-2, class D
- Voltage Fluctuations & Flicker		EN 61000-3-3
<b>EMC Immunity</b>		EN 55024 (IT Equipment)
- Electrostatic Discharge		EN 60601-1-2 edition 4 (Medical Devices)
	Air:	EN 61000-4-2, ±15 kV, perf. criteria A
	Contact:	EN 61000-4-2, ±8 kV, perf. criteria A EN 61000-4-3, 20 V/m, perf. criteria A EN 61000-4-4, ±2 kV, perf. criteria A
- RF Electromagnetic Field		
- EFT (Burst)		
- Surge	L to L:	EN 61000-4-5, ±1 kV, perf. criteria A
	L to PE:	EN 61000-4-5, ±2 kV, perf. criteria A
- Conducted RF Disturbances		EN 61000-4-6, 20 Vrms, perf. criteria A
- PF Magnetic Field		EN 61000-4-8, 10 A/m, perf. criteria A
- Voltage Dips & Interruptions	230 VAC / 50 Hz:	EN 61000-4-11 30%, perf. criteria A, 25 periods >95%, perf. criteria A, 0.5 periods >95%, perf. criteria A, 1 period >95%, perf. criteria B, 250 periods
	115 VAC / 60 Hz:	EN 61000-4-11 30%, 25 periods, perf. criteria A >95%, 0.5 periods, perf. criteria A >95%, 1 period, perf. criteria A >95%, 250 periods, perf. criteria B

## General Specifications

<b>Relative Humidity</b>		95% max. (non condensing)
<b>Temperature Ranges</b>	- Operating Temperature	-25°C to +85°C
	- Storage Temperature	-40°C to +85°C
<b>Power Derating</b>	- High Temperature	2 %/K above 55°C
	- Low Input Voltage	1.33 %/V below 100V
<b>Cooling system</b>		Natural convection (no internal fan, 20 LFM)
<b>Altitude during Operation</b>		5000 m max.
<b>Switching Frequency</b>		45 - 75 kHz (PWM QR)
<b>Insulation System</b>		Reinforced Insulation
<b>Working Voltage (rated)</b>		250 VAC
<b>Isolation Test Voltage</b>	- Input to Output, 60 s	5'657 VDC
	- Input to Case or PE, 60 s	2'121 VDC
	- Output to Case or PE, 60 s	2'121 VDC
<b>Isolation Resistance</b>	- Input to Output, 500 VDC	100 MOhm min.
<b>Leakage Current</b> (264 VAC)	- Touch Current	75 µA max.
<b>Reliability</b>	- Calculated MTBF	790'000 h (acc. to MIL-HDBK-217F)
<b>Environment</b>	- Vibration	IEC 60068-2-6
	- Mechanical Shock	IEC 60068-2-27
	- Thermal Shock	MIL-STD-810F
<b>Connection Type</b>		JST

All specifications valid at nominal input voltage, full load and +25°C after warm-up time unless otherwise stated.

Weight	156 g
Environmental Compliance - Reach	<a href="http://www.tracopower.com/info/reach-declaration.pdf">www.tracopower.com/info/reach-declaration.pdf</a>
- RoHS	<a href="http://www.tracopower.com/info/rohs-declaration.pdf">www.tracopower.com/info/rohs-declaration.pdf</a>

### Supporting Documents

Overview Link (for additional Documents)	<a href="http://www.tracopower.com/overview/tpp100a-j">www.tracopower.com/overview/tpp100a-j</a>
--	--

### Outline Dimensions

Each one of the 4 screw holes can be used as a PE connection for CLASS I application.

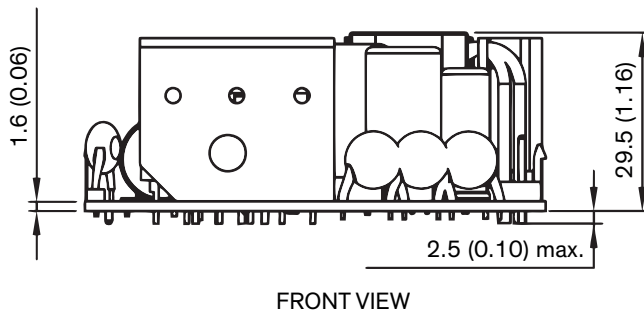
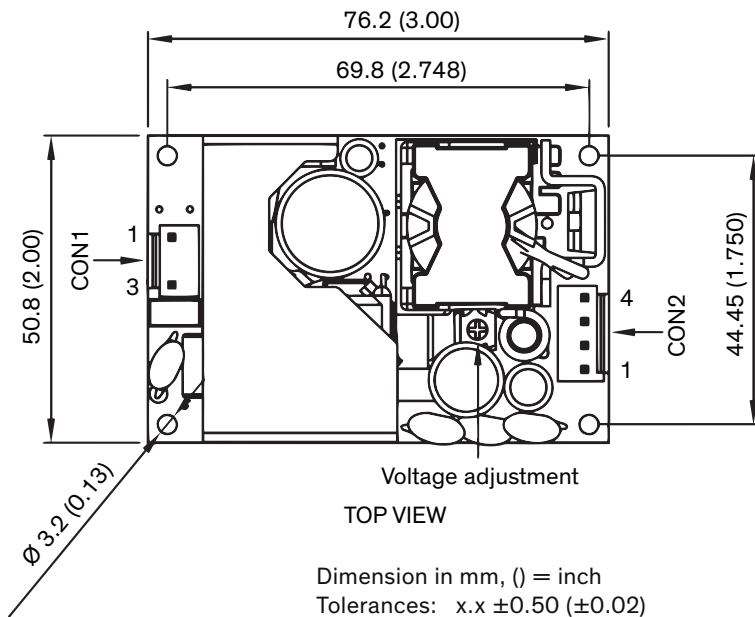

Pin connectors			
Input (CON1)		Output (CON2)	
Pin	Function	Pin*	Function
1	Line	1,2	-Vout
3	Neutral	3,4	+Vout

\*Terminal rated for 7 A max.  
(at higher current connection has to be split)

**CON1:** JST series  
mates with JST crimp terminal: SVH-21T-P1.1  
and terminal housing: VHR-3N

**CON2:** JST series  
mates with JST crimp terminal: SVH-21T-P1.1  
and terminal housing: VHR-4N