



VISHAY "S" SERIES

High-Performance Aerospace and Instrumentation Resistors

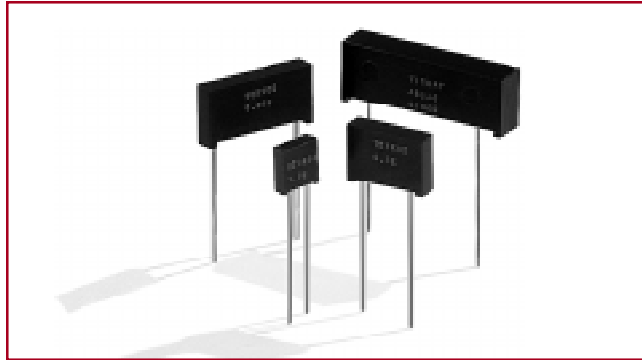
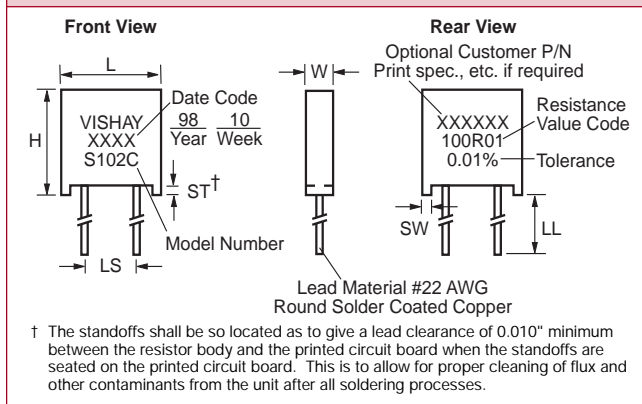

FIGURE 1 - STANDARD IMPRINTING AND DIMENSIONS



The "S" series of resistors and in particular the S102C is the starting point in the selection of foil resistors. Vishay has the longest history and most supporting data on this product. All other foil resistors are offshoots of this initial endeavor and provide unique features beyond the range of the "S" series.

FEATURES

- S102K Series Nominal Temperature Coefficient of Resistance: -0.3 ppm/°C (0°C to +25°C); +0.3 ppm/°C (+25°C to +60°C); -1.0 ppm/°C (-55°C to +25°C); +1.0ppm/°C (+25°C to +125°C)
- S102C Series Nominal Temperature Coefficient of Resistance: +0.6 ppm/°C (0°C to +25°C); -0.6 ppm/°C (+25°C to +60°C); +2.2 ppm/°C (-55°C to +25°C); -1.8 ppm/°C (+25°C to +125°C)
- Selected TCR Tracking: to 0.5 ppm/°C (matched sets)
- Shelf Life Stability: ±25 ppm maximum for 1 year
- Power Rating: 0.6 to 2.0 Watts at +70°C; 0.3 to 1.0 Watts at +125°C (depending on model)
- Load Life Stability: ±150 ppm Max deltaR (2,000 hrs. at rated power)
- Resistance Tolerance (Initial Resistance Accuracy): ±0.005% tightest to ±1.0% loosest (depends on resistor value)
- Resistance Range: 0.5 Ω to 1M Ω
- Current Noise: 0.010 μV (RMS)/Volt of Applied Voltage
- Thermal EMF: 0.1 μV/°C Maximum; 0.05 μV/°C Typical; 1 μV/watt (Model S102C, S102K)
- Rise/Decay Time: 1.0 nanosec @ 1K Ω

TABLE 1 - MODEL SELECTION

Model Number	Resistance Range (Ω)	Maximum Working Voltage ²	Ambient Power Rating ³		Average Weight In Grams	Dimensions			Tightest Tolerance% Vs. Lowest Resistance Value Ω
			@+70°C	@+125°C		Inches	mm	*F (inches)	
S102C	1 to 150K	300	0.6 W	0.3 W up to 100K	0.6	W: 0.105 ±0.010 L: 0.300 ±0.010 H: 0.326 ±0.010 ST: 0.010 Min SW: 0.040 ±0.005 LL: 1.000 ±0.125 LS: 0.150 ±0.005 ⁴	2.67 ±0.25 7.62 ±0.25 8.28 ±0.25 0.254 Min 1.02 ±0.13 25.4 ±3.18 3.81 ±0.13		±0.005 / 50 ±0.01 / 25 ±0.02 / 12 ±0.05 / 5 ±0.1 / 2 ±0.5 / 1 ±1 / 0.5
S102K	1 to 100K		0.4 W	0.2 W over 100K					
S104D (S104F*)	1 to 500K	350	1.0 W	0.5 W up to 200K	1.4	W: 0.160 Max L: 0.575 Max H: 0.413 Max ST: 0.035 ±0.005 SW: 0.050 ±0.005 LL: 1.000 ±0.125 LS: 0.400 ±0.020	4.06 Max 14.61 Max 10.49 Max 0.889 ±0.13 1.27 ±0.13 19.05 ±3.18 10.16 ±0.51	(0.138") (0.565") (0.413")	
S104K	1 to 300K		0.6 W	0.3 W over 200K					
S105D (S105F*)	1 to 750K	350	1.5 W	0.75 W up to 300K	1.9	W: 0.160 Max L: 0.820 Max H: 0.413 Max ST: 0.035 ±0.005 SW: 0.050 ±0.005 LL: 1.000 ±0.125 LS: 0.650 ±0.020	4.06 Max 20.83 Max 10.49 Max 0.889 ±0.13 1.27 ±0.13 19.05 ±3.18 16.51 ±0.51	(0.138") (0.890") (0.413")	
S 105K	1 to 500K		0.8 W	0.4 W over 300K				(0.7 ±0.02")	
S106D	0.5 to 1M	500	2.0 W	1.0 W up to 400K	4.0	W: 0.260 Max L: 1.200 Max H: 0.413 Max ST: 0.035 ±0.005 SW: 0.050 ±0.005 LL: 1.000 ±0.125 LS: 0.900 ±0.020	6.60 Max 30.48 Max 10.49 Max 0.889 ±0.13 1.27 ±0.13 19.05 ±3.18 22.86 ±0.51		
S106K	0.5 to 600K		1.0 W	0.5 W over 400K					

*S104F and S105F have different package dimensions (see last column). All other specifications are the same.

THROUGH HOLE



VISHAY "S" SERIES

High-Performance Aerospace and Instrumentation Resistors

THROUGH HOLE

TABLE 2 - "S" SERIES SPECIFICATIONS⁵

Temperature Coefficient of Resistance S102K	
Nominal TCR ⁶ (See Fig. 7 and 8, Page 3)	-0.3 ppm/°C (0°C to +25°C) +0.3 ppm/°C (+25° to +60°C) -1.0 ppm/°C (-55°C to +25°C) +1.0 ppm/°C (+25°C to +125°C)
Maximum TCR (See Fig. 7 and 8, Page 3)	±2.5 ppm/°C (0°C to +25°C and +25°C to +60°C) ±2.5 ppm/°C (-55°C to +25°C and +25°C to +125°C)
Selected ⁹ TCR Tracking ¹⁰ (Closest Spread)	0.5 ppm/°C
S102C	
Nominal TCR ⁶ (See Fig. 1 and 2, Page 1)	+0.6 ppm/°C (0°C to +25°C) -0.6 ppm/°C (+25°C to +60°C) +2.2 ppm/°C (-55°C to +25°C) -1.8 ppm/°C (+25°C to +125°C)
Standard TCR Spread from Nominal ⁷ (See Fig. 5 and 6, Page 2)	±1.5 ppm/°C (0°C to +25°C and +25°C to +60°C) ±2.0 ppm/°C (-55°C to +25°C and +25°C to +125°C)
Maximum TCR Spread from Nominal ¹⁴ (See Fig. 5 and 6, Page 2)	±2.5 ppm/°C (0°C to +25°C and +25°C to +60°C) ±2.3 ppm/°C (-55°C to +25°C and +25°C to +125°C)
Selected ⁹ TCR Tracking ¹⁰	0.5 ppm/°C
Stability¹⁵	
Load Life at 2,000 hrs.	±0.015% Max Δ R @ 0.3 W/+125°C ±0.005% Max Δ R @ 0.1 W/+70°C
Load Life at 10,000 hrs.	±0.05% Max Δ R @ 0.3 W/+125°C ±0.01% Max Δ R @ 0.05 W/+125°C
Shelf Life Stability	
	±0.0025% Max Δ R after 1 year ±0.005% Max Δ R after 3 years
Current Noise	
	0.010 μV (RMS)/Volt of applied voltage (-40 dB)
High Frequency Operation	
Rise/Decay Time	1.0 ns at 1K Ω
Inductance (L) ¹¹	0.1 μH maximum; 0.08 μH typical
Capacitance (C)	1.0 pF maximum; 0.5 pF typical
Voltage Coefficient	
	<0.1 ppm/V ¹²
Thermal EMF¹³	
	0.1 μV/°C Max; 0.05 μV/°C Typical 1 μV/watt (Model S102C)

FIGURE 2 - POWER DERATING CURVE "S" SERIES

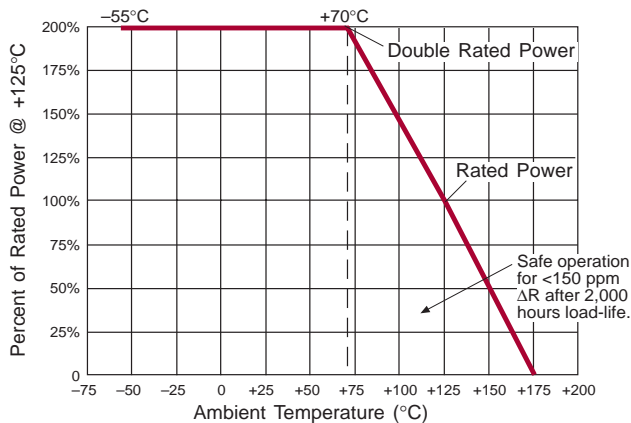

NOTES:

- Standard Resistance Tolerance: ±0.005%; ±0.01%; ±0.02%; ±0.05%; ±0.1%; ±0.25%; ±0.5%; ±1.0%.
- Not to exceed power rating of resistor.
- See Figure 2.
- 0.200" (5.08 mm) lead spacing available- specify S102J for S102C, and S102L for S102K.
Note its Minor Outline Dimension Variations:

	Inches	mm
W:	0.098 Max.	2.49 Max.
L:	0.295 Max.	7.49 Max.
H:	0.315 Max.	8.00 Max.
ST:	0.01 Min.	0.254 Min.
LL:	0.875 Min.	22.23 Min.
LS:	0.200 ±0.003	5.08 ±0.076
- Maximum is 1.0% A.Q.L. standard for all specifications except TCR. (For TCR information, see notes 6-10 and 14). Typical is a designers reference which represents that 85% of the units supplied, over a long period of time, will be at least the figure shown or better.
- Vishay Nominal TCR is defined as the chord slopes of the relative change of resistance/temperature, expressed in ppm (parts per million), called (RT) curve from 0°C to +25°C and +25°C to +60°C ("Instrument" Range); and from -55°C to +25°C and +25°C to +125°C ("Military" Range). These specifications and the definition of Nominal TCR apply to all resistance values including low-value resistors.
- Vishay Standard TCR Spread is defined as a designers reference which represents that at least 92% of the units, and 82% of the lots, supplied by Vishay will be within the stated band centered on the nominal curve. This definition of the Vishay Standard TCR Spread from Nominal applies to all resistance values. However, as the resistance value decreases below 60 Ω, the Vishay Standard TCR Spread from Nominal specification starts to increase. (See Figure 3, Page 2.)
- Vishay Maximum TCR Spread is defined as the 3 σ (Sigma) limit of a normal Gaussian distribution (99.73% of a production lot) which is within a band, centered on the nominal curve. This Vishay Maximum TCR Spread is no greater than ±2.5 ppm/°C from nominal throughout the full temperature range. This definition of the Vishay Maximum TCR Spread from Nominal applies to all resistance values. However, as the resistance value decreases below 80 Ω, the Vishay maximum TCR Spread from Nominal specification starts to increase. (See Figure 3, Page 2.)
- Selected TCR Tracking is available for specially ordered lots of resistors. The selected TCR tracking can be 3, 2, 1 and as close as 0.5 ppm/°C throughout the full temperature range.
- TCR tracking is a measure of the similarity of resistance value change in two or more resistors which are undergoing the same temperature changes. Tracking could be expressed as the difference in the temperature coefficients of the resistors, expressed in ppm/°C as $(\Delta R_1/R_1 - \Delta R_2/R_2) \times 10^{-6}/\Delta T^\circ C$. When a number of resistors are referenced to a nominal TCR, the spread or envelope around the nominal would be the difference. If the spread is ±1.5 ppm/°C about a nominal, the tracking, as defined above, will be 3 ppm/°C. For sets comprising different values, tracking can be defined with reference to a given value.
- Inductance (L) due mainly to the leads.
- The resolution limit of existing test equipment (within the measurement capability of the equipment, or "essentially zero.")
- μV/°C relates to EMF due to lead temperature difference and μV/watt due to power applied to the resistor.
- +4.5 ppm/°C is the worst case (maximum) TCR for a Vishay resistor over the temperature range of -55°C to +125°C. +4.5 ppm/°C is derived from the S102C (-55°C to +25°C) nominal TCR of +2.2 ppm/°C plus the maximum TCR spread figure of +2.3 ppm/°C. Other temperature ranges and TCR data will yield a lower maximum characteristic. See Figures 5, 6, 7 and 8 on Pages 2 and 3 and see Table 2 above.
- Load life Δ R Maximum can be reduced by 80% through a burn-in procedure.



VISHAY "S" SERIES

High-Performance Aerospace and Instrumentation Resistors

	MIL-R-55182 Char J	S-Series Max ΔR ⁵	S-Series Typ ΔR ⁵
TEST GROUP I Thermal Shock Overload	±0.2% ±0.2%	±0.01% ±0.01%	±0.002% ±0.003%
TEST GROUP II Resistance Temperature Characteristic Low Temp Storage Low Temp Operation Terminal Strength	±25 ppm/°C ±0.15% ±0.15% ±0.2%	+4.5 ppm/°C ¹⁴ ±0.01% ±0.01% ±0.01%	See Figs. 5, 6, 7, 8 Pgs. 2 - 3 ±0.005% ±0.005% ±0.002%
TEST GROUP III DWV Resistance to Solder Heat Moisture Resistance	±0.15% ±0.1% ±0.4%	±0.01% ±0.01% ±0.05%	±0.005% ±0.002% ±0.02%
TEST GROUP IV Shock Vibration	±0.2% ±0.2%	±0.01% ±0.01%	±0.002% ±0.002%
TEST GROUP V Life Test @ 0.3 W/+125°C 2,000 Hours 10,000 Hours	±0.5% ±2.0%	±0.015% ±0.05%	±0.01% ±0.03%
TEST GROUP Va +70°C Power Rating	±0.5%	±0.1%	±0.05%
TEST GROUP VI High Temp Exposure	±0.5%	±0.1%	±0.05%
TEST GROUP VII Voltage Coefficient	0.005%/V	<0.00001%/V ¹²	<0.00001%/V ¹²

See page 12 for numbered footnotes.

STANDARD OPERATIONS & TEST CONDITIONS

- A. Standard Test Operations:
- By 100% Inspection
 - Short-time overload (6.25 X rated power for 5 seconds)
 - Resistance – tolerance check
 - Visual and mechanical
 - By Sample Inspection
 - TCR
 - Environmental tests per Table 3 on a quarterly basis to establish performance by similarity.
- B. Standard Test Conditions:
- Lead test point: 0.5" (12.7 mm) from resistor body
 - Temperature: +22°C ±2°C
 - Relative humidity: per MIL-Std-202

IMPROVED PERFORMANCE TESTING

The preceding information is based on product directly off the production line. Improved performance (meaning increased time stability with load and other stresses) is available through factory conducted "Improved Performance Testing". The test routine is usually tailored to the users stability objectives and product that has been screened can be brought down to a potential load life of less than 50 ppm. For example, Figure 12, Page 5 shows the drift characteristics of standard product.

Various screen test routines are available and all anticipated stresses must be taken into account before settling on one specific test routine. Our Applications Engineering Department (610) 644-1300 is prepared to discuss and recommend appropriate routines given the full spectrum of anticipated stresses and stability requirements.

HOW TO ORDER "S" SERIES PARTS:

Please specify Vishay "S" Series resistors as follows: (See Imprinting Illustration and Table 1 for further details).

Example:

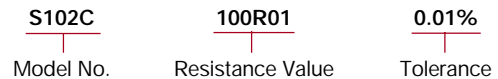

Resistance Value, in ohms, is expressed by a series of 6 characters, 5 of which represent significant digits while the 6th is a dual purpose letter that designates both the multiplier and the location of the comma or decimal point.

Resistance Range	Letter Designator	Multiplier Factor	Example
0.5 Ω to <1K Ω	R	x1	100R01 = 100.01 Ω
1K Ω to <1M Ω	K	x10 ³	15K231 = 15,231 Ω
1M Ω	M	x10 ⁶	1M0000 = 1,000,000 Ω

THROUGH HOLE