

Transistor, NPN TO-3

multicomp^{PRO}



Description:

High power NPN silicon power transistors.

These devices are designed for linear amplifiers, series pass regulators, and inductive switching applications.

Features:

- Forward biased second breakdown current capability
 $I_{S/b} = 2.5A$ DC at $V_{CE} = 60V$ DC
- Pb-free packages

Maximum Ratings

Rating	Symbol	2N3772	Unit
Collector-Emitter Voltage	V_{CEO}	60	V DC
Collector-Emitter Voltage	V_{CEX}	80	
Collector-Base Voltage	V_{CB}	100	
Emitter-Base Voltage	V_{EB}	7	
Collector Current - Continuous - Peak	I_C	20 30	A DC
Base Current - Continuous - Peak	I_B	5 15	
Total Device Dissipation at $T_C = 25^\circ C$ Derate above $25^\circ C$	P_D	150 0.855	W W/ $^\circ C$
Operating and Storage Junction Temperature Range	T_J, T_{stg}	-65 to +200	$^\circ C$

Thermal Characteristics

Characteristic	Symbol	Max.	Unit
Thermal Resistance Junction to Case	R_{jc}	1.17	$^\circ C/W$

Stresses exceeding maximum ratings may damage the device. Maximum ratings are stress ratings only. Functional operation above the recommended operating conditions is not implied. Extended exposure to stresses above the recommended operating conditions may affect device reliability.

1. Indicates JEDEC registered data.

Transistor, NPN TO-3

multicomp **PRO**

Electrical Characteristics (TC = 25°C unless otherwise noted)

Characteristic	Symbol	Min.	Max.	Unit
----------------	--------	------	------	------

Off Characteristics

Collector-Emitter Sustaining Voltage (Note 2 and 3) ($I_C = 0.2A$ DC, $I_B = 0$)	$V_{EO(sus)}$	60	-	V DC
Collector-Emitter Sustaining Voltage ($I_C = 0.2A$ DC, $V_{EB(off)} = 1.5$ V DC, $R_{BE} = 100\Omega$)	$V_{CEX(sus)}$	80	-	
Collector-Emitter Sustaining Voltage ($I_C = 0.2A$ DC, $R_{BE} = 100\Omega$)	$V_{CER(sus)}$	70	-	
Collector Cut off Current (Note 2) ($V_{CE} = 50V$ DC, $I_B = 0$) ($V_{CE} = 25V$ DC, $I_B = 0$)	I_{CEO}	-	10	mA DC mA DC
Collector Cut off Current (Note 2) ($V_{CE} = 100V$ DC, $V_{EB(off)} = 1.5V$ DC) ($V_{CE} = 45V$ DC, $V_{EB(off)} = 1.5V$ DC, $T_C = 150^\circ C$)	I_{CEV}	-	5 10	
Collector Cut off Current (Note 2) ($V_{CB} = 100V$ DC, $I_E = 0$)	I_{CBO}	-	5	
Emitter Cut off Current (Note 2) ($V_{BE} = 7V$ DC, $I_C = 0$)	I_{EBO}	-	5	

On Characteristics (Note 2)

DC Current Gain (Note 3) ($I_C = 10A$ DC, $V_{CE} = 4V$ DC) ($I_C = 20A$ DC, $V_{CE} = 4V$ DC)	h_{FE}	15 5	60 -	-
Collector-Emitter Saturation Voltage ($I_C = 10A$ DC, $I_B = 1A$ DC) ($I_C = 20A$ DC, $I_B = 4A$ DC)	$V_{CE(sat)}$	-	1.4 4	V DC
Base-Emitter on Voltage ($I_C = 10A$ DC, $V_{CE} = 4V$ DC) ($I_C = 8A$ DC, $V_{CE} = 4V$ DC)	$V_{BE(on)}$	-	2.2	

Dynamic Characteristics (Note 2)

Current-Gain - Bandwidth Product ($I_C = 1A$ DC, $V_{CE} = 4V$ DC, $f_{test} = 50kHz$)	f_T	0.2	-	MHz
Small-Signal Current Gain ($I_C = 1A$ DC, $V_{CE} = 4V$ DC, $f = 1kHz$)	h_{fe}	40	-	-

Second Breakdown

Second Breakdown Energy with Base Forward Biased, $t = 1s$ (non-repetitive) ($V_{CE} = 60V$ DC)	$I_{S/b}$	2.5	-	A DC
---	-----------	-----	---	------

2. Indicates JEDEC registered data

3. Pulse Test: 300 μ s, Rep. Rate 60cps

Newark.com/multicomp-pro
Farnell.com/multicomp-pro
Element14.com/multicomp-pro

multicomp **PRO**

Transistor, NPN TO-3

multicomp **PRO**

Power Derating

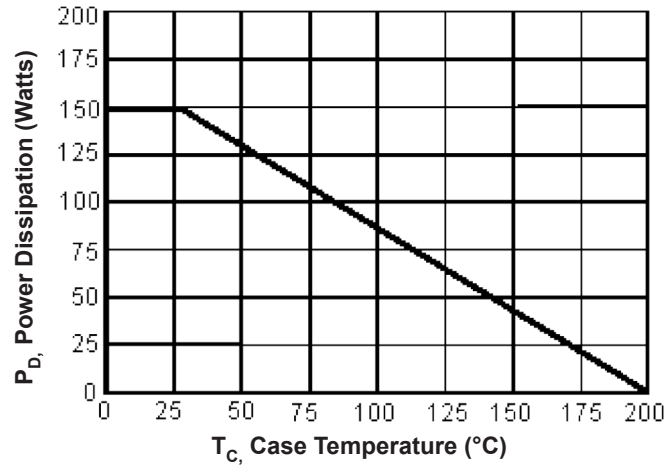

Turn-Off Time

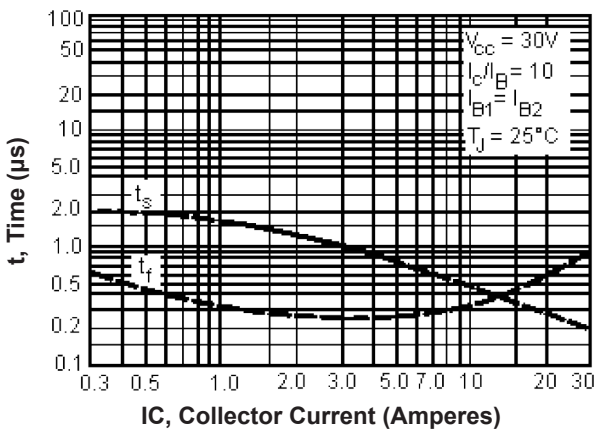

Capacitance

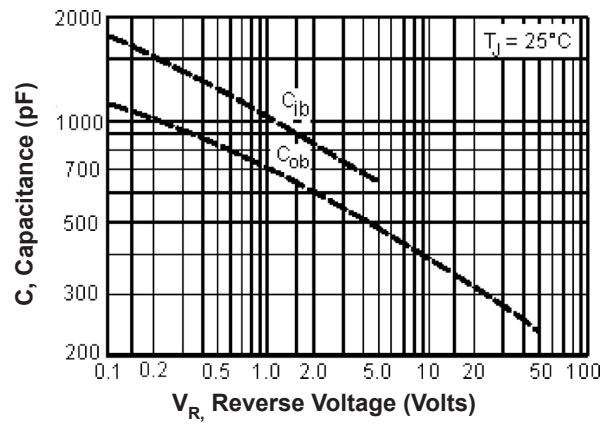

DC Current Gain

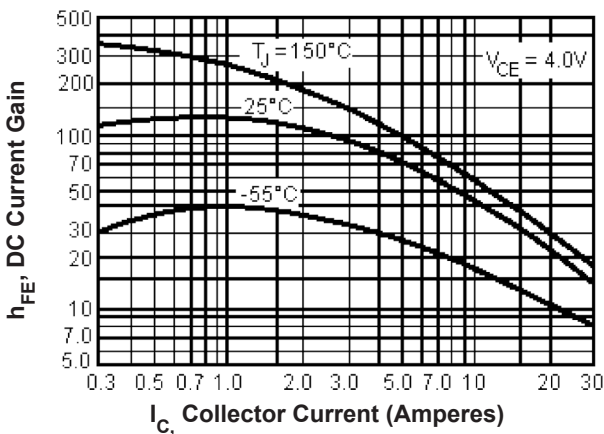

Collector Saturation Region

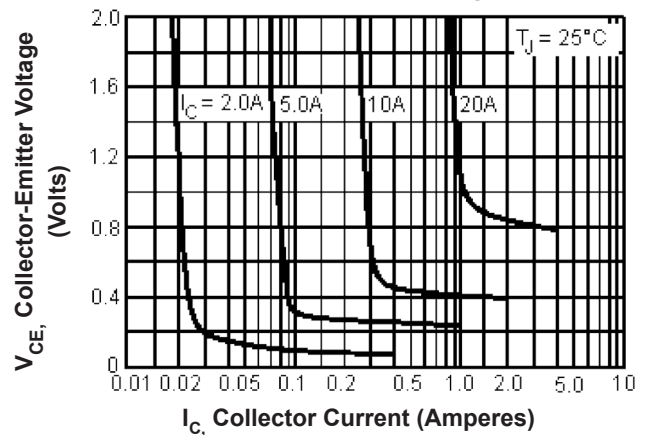

multicomp **PRO**

Transistor, NPN TO-3

Thermal Response

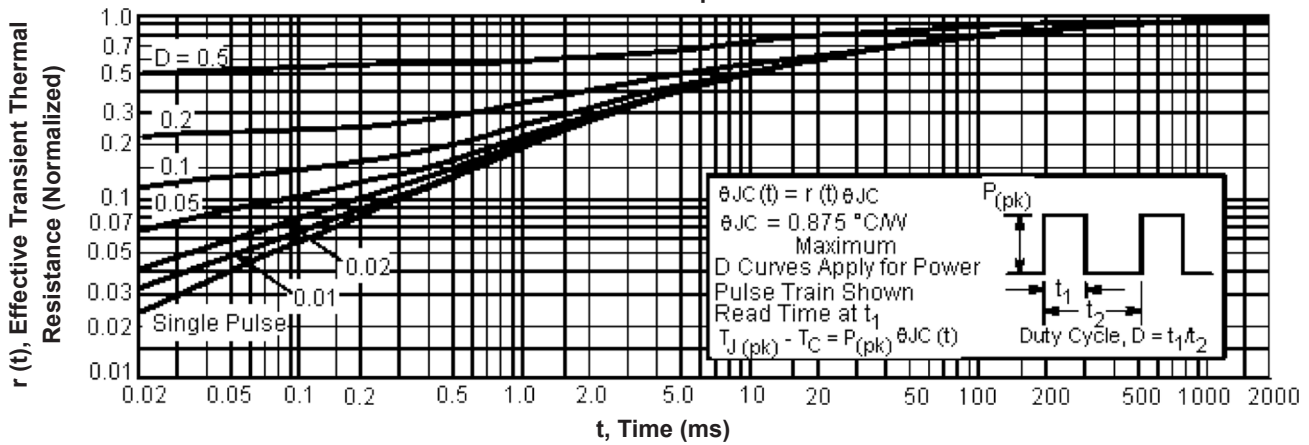

Active-Region Safe Operating Area

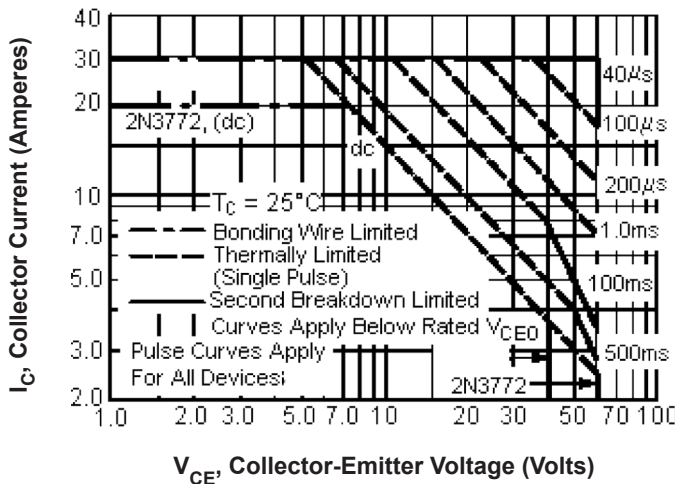

There are two limitations on the power handling ability of a transistor: average junction temperature and second breakdown. Safe operating area curves indicate $I_C - V_{CE}$ limits of the transistor that must be observed for reliable operation; i.e., the transistor must not be subjected to greater dissipation than the curves indicate.

Is based on JEDEC registered data. Second breakdown pulse limits are valid for duty cycles to 10% provided $T_{J(pk)} < 200^\circ\text{C}$. $T_{J(pk)}$ may be calculated from the data of using data of and the pulse power limits of Figure 3, $T_{J(pk)}$ will be found to be less than $T_{J(max)}$ for pulse widths of 1ms and less. When using ON Semiconductor transistors, it is permissible to increase the pulse power limits until limited by $T_{J(max)}$.

Turn-On Time

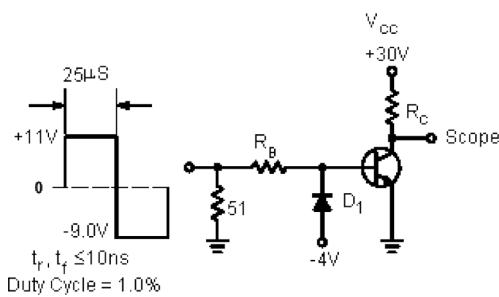
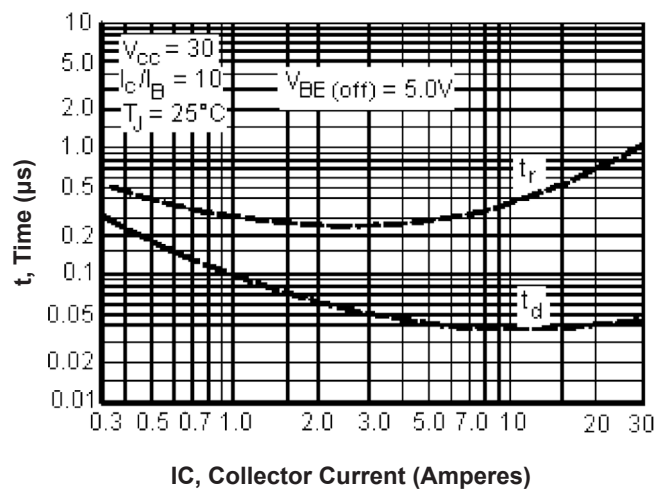

R_B and R_C are varied to obtain desired current levels
 D_1 must be fast recovery type, e.g.:
 1N5825 used above I_B to 100mA
 MSD6100 used below I_B to 100mA

Switching Time Test Circuit

Transistor, NPN TO-3

Dimensions

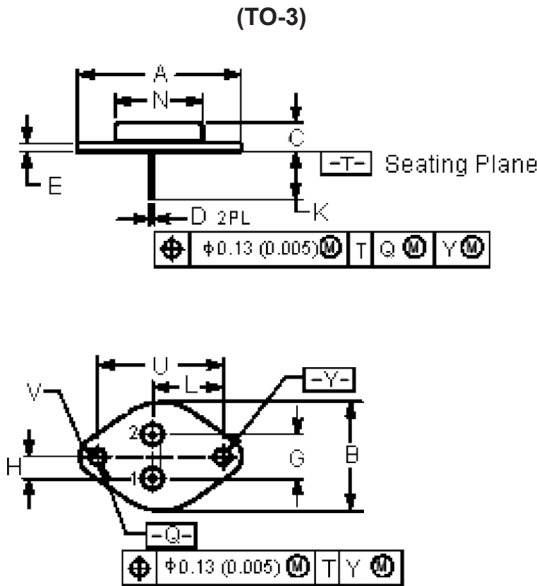

Dimensions	Min.	Max.
A	1.55 (39.37)	Reference
B	-	1.05 (26.67)
C	0.25 (6.35)	0.335 (8.51)
D	0.038 (0.97)	0.043 (1.09)
E	0.055 (1.4)	0.07 (1.77)
G	0.43 (10.92) BSC	
H	0.215 (5.46) BSC	
K	0.44 (11.18)	0.48 (12.19)
L	0.665 (16.89) BSC	
N	-	0.83 (21.08)
Q	0.151 (3.84)	0.165 (4.19)
U	1.187 (30.15) BSC	
V	0.131 (3.33)	0.188 (4.77)

Dimensions : Inches (Millimetres)

Pin Configuration

- Pin 1. Base
- 2. Emitter
- Collector (Case)

Part Number Table

Description	Part Number
Transistor, NPN, TO-3	2N3772

Important Notice : This data sheet and its contents (the "Information") belong to the members of the AVNET group of companies (the "Group") or are licensed to it. No licence is granted for the use of it other than for information purposes in connection with the products to which it relates. No licence of any intellectual property rights is granted. The Information is subject to change without notice and replaces all data sheets previously supplied. The Information supplied is believed to be accurate but the Group assumes no responsibility for its accuracy or completeness, any error in or omission from it or for any use made of it. Users of this data sheet should check for themselves the Information and the suitability of the products for their purpose and not make any assumptions based on information included or omitted. Liability for loss or damage resulting from any reliance on the Information or use of it (including liability resulting from negligence or where the Group was aware of the possibility of such loss or damage arising) is excluded. This will not operate to limit or restrict the Group's liability for death or personal injury resulting from its negligence. Multicomp Pro is the registered trademark of Premier Farnell Limited 2019.