

## Product Change Notification - SYST-18KAOU710

---

**Date:**

22 Jul 2019

**Product Category:**

32-bit Microcontrollers

**Affected CPNs:**

**Notification subject:**

Data Sheet - SAM D5X/E5X Family Datasheet Data Sheet Document Revision

**Notification text:**

SYST-18KAOU710

Microchip has released a new DeviceDoc for the SAM D5X/E5X Family Datasheet of devices. If you are using one of these read the document located at [SAM D5X/E5X Family Datasheet](#).

**Notification Status:** Final

**Description of Change:** This revision includes the following changes

Section Name	Update Description
Introduction	Updated sections: <ul style="list-style-type: none"> <li>&amp;bull; Updated Features</li> <li>&amp;bull; Updated the Configuration Summary</li> </ul>
Processor and Architecture	Updated Interrupt Line Mapping
CMCC	Updated sections: <ul style="list-style-type: none"> <li>&amp;bull; Data Cache Disable</li> <li>&amp;bull; Instruction Cache Disable</li> </ul>
GCLK	Updated the PCHCTRLm register
PM	Updated Backup Mode
RTC	Count32 Registers updated: <ul style="list-style-type: none"> <li>&amp;bull; CTRLA</li> <li>&amp;bull; EVCTRL</li> <li>&amp;bull; INTENCLR</li> <li>&amp;bull; INTENSET</li> <li>&amp;bull; INTFLAG</li> <li>&amp;bull; SYNCBUSY</li> <li>&amp;bull;</li> </ul> Count16 Registers updated:

	<ul style="list-style-type: none"> <li>&amp;bull; CTRLA</li> <li>&amp;bull; EVCTRL</li> <li>&amp;bull; INTENCLR</li> <li>&amp;bull; INTENSET</li> <li>&amp;bull; INTFLAG</li> <li>&amp;bull; SYNCBUSY</li> <li>&amp;bull;</li> </ul> <p>The following Clock registers were updated:</p> <ul style="list-style-type: none"> <li>&amp;bull; CTRLA</li> <li>&amp;bull; EVCTRL</li> <li>&amp;bull; INTENCLR</li> <li>&amp;bull; INTENSET</li> <li>&amp;bull; INTFLAG</li> <li>&amp;bull; SYNCBUSY</li> <li>&amp;bull;</li> </ul>
DMAC	<p>The following topics were updated:</p> <ul style="list-style-type: none"> <li>&amp;bull; Initialization</li> <li>&amp;bull; Enabling, Disabling and Resetting</li> <li>&amp;bull; Transfer Descriptors</li> </ul> <p>The following registers were updated:</p> <ul style="list-style-type: none"> <li>&amp;bull; CTRL</li> <li>&amp;bull; SWTRIGCTRL</li> <li>&amp;bull; INTSTATUS</li> <li>&amp;bull; BUSYCH</li> </ul>
GMAC	<p>The following topics were updated:</p> <ul style="list-style-type: none"> <li>&amp;bull; Features</li> </ul>

	<ul style="list-style-type: none"> <li>• Pause Frame Reception</li> </ul>
OSCCTRL	<p>The following topics were updated:</p> <ul style="list-style-type: none"> <li>• Digital Phase Locked Loop (DPLL) Operation</li> </ul>
SERCOM-SPI	<p>Updated the following topics:</p> <ul style="list-style-type: none"> <li>• Clock Generation</li> </ul>
QSPI	<p>Updated the following topics:</p> <ul style="list-style-type: none"> <li>• Continuous Read Mode</li> </ul>
SDMMC	<p>Updated the following registers:</p> <ul style="list-style-type: none"> <li>• PSR</li> <li>• PCR</li> <li>• NISTR</li> <li>• NISTER</li> <li>• HC2R EMMC</li> <li>• HC2R SDIO</li> <li>• CA0R</li> <li>• CA1R</li> <li>• MCCAR</li> <li>• ASAR</li> <li>•</li> <li>• MC1R</li> <li>• ACR</li> </ul>
ADC	Updated the INPUTCTRL register
AC	<p>Updated the following sections:</p> <ul style="list-style-type: none"> <li>• Signal Description</li> </ul>
TC	<p>Updated the following sections:</p> <ul style="list-style-type: none"> <li>• Counter Mode</li> </ul>
TCC	<p>Updated the following sections:</p> <ul style="list-style-type: none"> <li>• Capture Operations</li> </ul> <p>Updated the following registers:</p> <ul style="list-style-type: none"> <li>• WAVE</li> </ul>
I2S	Updated the following sections:

	<ul style="list-style-type: none"> <li>&amp;bull; DMA Operation</li> </ul> <p>Updated the following registers:</p> <ul style="list-style-type: none"> <li>&amp;bull; CTRLA</li> <li>&amp;bull; INTENCLR</li> <li>&amp;bull; INTENSET</li> <li>&amp;bull; INTFLAG</li> <li>&amp;bull; SYNCBUSY</li> <li>&amp;bull; TXCTRL</li> <li>&amp;bull; RXCTRL</li> </ul>
<p>Electrical Characteristics at 85&amp;deg;C</p>	<p>Updated the following sections:</p> <ul style="list-style-type: none"> <li>&amp;bull; General Operating Ratings</li> <li>&amp;bull; Injection Current</li> <li>&amp;bull; Power Consumption</li> <li>&amp;bull; Analog-to-Digital Characteristics</li> <li>&amp;bull; Digital-to-Analog Converter Characteristics</li> </ul> <p>Added in :</p> <ul style="list-style-type: none"> <li>&amp;bull; PTC Characteristics</li> </ul>
<p>Electrical Characteristics at 105&amp;deg;C</p>	<p>Updated the following sections:</p> <ul style="list-style-type: none"> <li>&amp;bull; Power Consumption</li> <li>&amp;bull; Digital-to-Analog Converter Characteristics</li> <li>&amp;bull; Analog-to-Digital Characteristics</li> </ul> <p>Added new section:</p> <ul style="list-style-type: none"> <li>&amp;bull; PTC Characteristics</li> </ul>
<p>Electrical Characteristics at 125&amp;deg;C</p>	<p>Updated the following sections:</p> <ul style="list-style-type: none"> <li>&amp;bull; Power Consumption</li> <li>&amp;bull; Analog-To-Digital Characteristics</li> <li>&amp;bull; Digital-to-Analog Characteristics</li> </ul>



	Added new section:
--	--------------------

	• PTC Characteristics
--	-----------------------

**Impacts to Data Sheet:** None

**Reason for Change:** To Improve Manufacturability

**Change Implementation Status:** Complete

**Date Document Changes Effective:** 22 Jul 2019

**NOTE:** Please be advised that this is a change to the document only the product has not been changed.

**Markings to Distinguish Revised from Unrevised Devices:** N/A

**Attachment(s):**

[SAM D5X/E5X Family Datasheet](#)

Please contact your local [Microchip sales office](#) with questions or concerns regarding this notification.

**Terms and Conditions:**

If you wish to receive Microchip PCNs via email please register for our PCN email service at our [PCN home page](#) select register then fill in the required fields. You will find instructions about registering for Microchips PCN email service in the [PCN FAQ](#) section.

If you wish to change your PCN profile, including opt out, please go to the [PCN home page](#) select login and sign into your myMicrochip account. Select a profile option from the left navigation bar and make the applicable selections.

Affected Catalog Part Numbers (CPN)

ATSAMD51G18A-MF  
ATSAMD51G18A-MFT  
ATSAMD51G18A-MU  
ATSAMD51G18A-MU-EFP  
ATSAMD51G18A-MUT  
ATSAMD51G18A-MUT-EFP  
ATSAMD51G18A-MZ  
ATSAMD51G18A-MZT  
ATSAMD51G19A-MF  
ATSAMD51G19A-MFT  
ATSAMD51G19A-MU  
ATSAMD51G19A-MU-EFP  
ATSAMD51G19A-MUT  
ATSAMD51G19A-MUT-EFP  
ATSAMD51G19A-MZ  
ATSAMD51G19A-MZT  
ATSAMD51J18A-AF  
ATSAMD51J18A-AFT  
ATSAMD51J18A-AU  
ATSAMD51J18A-AU-EFP  
ATSAMD51J18A-AUT  
ATSAMD51J18A-AUT-EFP  
ATSAMD51J18A-AZ  
ATSAMD51J18A-AZT  
ATSAMD51J18A-MF  
ATSAMD51J18A-MFT  
ATSAMD51J18A-MU  
ATSAMD51J18A-MU-EFP  
ATSAMD51J18A-MUT  
ATSAMD51J18A-MUT-EFP  
ATSAMD51J18A-MZ  
ATSAMD51J18A-MZT  
ATSAMD51J19A-AF  
ATSAMD51J19A-AFT  
ATSAMD51J19A-AU  
ATSAMD51J19A-AU-EFP  
ATSAMD51J19A-AUN02  
ATSAMD51J19A-AUT  
ATSAMD51J19A-AUT-EFP  
ATSAMD51J19A-AZ  
ATSAMD51J19A-AZT  
ATSAMD51J19A-MF  
ATSAMD51J19A-MFT  
ATSAMD51J19A-MU  
ATSAMD51J19A-MU-EFP  
ATSAMD51J19A-MUN01

ATSAMD51J19A-MUT  
ATSAMD51J19A-MUT-EFP  
ATSAMD51J19A-MUTN01  
ATSAMD51J19A-MZ  
ATSAMD51J19A-MZT  
ATSAMD51J19A-UNT  
ATSAMD51J19A-UUT  
ATSAMD51J19A-UUT-EFP  
ATSAMD51J19B-AF  
ATSAMD51J19B-AFT  
ATSAMD51J19B-AUN01  
ATSAMD51J19B-AUTN01  
ATSAMD51J20A-AF  
ATSAMD51J20A-AFT  
ATSAMD51J20A-AU  
ATSAMD51J20A-AU-EFP  
ATSAMD51J20A-AUT  
ATSAMD51J20A-AUT-EFP  
ATSAMD51J20A-AZ  
ATSAMD51J20A-AZT  
ATSAMD51J20A-AZTV03  
ATSAMD51J20A-MF  
ATSAMD51J20A-MFT  
ATSAMD51J20A-MU  
ATSAMD51J20A-MU-EFP  
ATSAMD51J20A-MUT  
ATSAMD51J20A-MUT-EFP  
ATSAMD51J20A-MZ  
ATSAMD51J20A-MZT  
ATSAMD51J20A-UNT  
ATSAMD51J20A-UUT  
ATSAMD51J20A-UUT-EFP  
ATSAMD51J20C-UUTN01  
ATSAMD51N19A-AF  
ATSAMD51N19A-AFT  
ATSAMD51N19A-AU  
ATSAMD51N19A-AU-EFP  
ATSAMD51N19A-AUT  
ATSAMD51N19A-AUT-EFP  
ATSAMD51N19A-AZ  
ATSAMD51N19A-AZT  
ATSAMD51N20A-AF  
ATSAMD51N20A-AFT  
ATSAMD51N20A-AU  
ATSAMD51N20A-AU-EFP  
ATSAMD51N20A-AUN02  
ATSAMD51N20A-AUT  
ATSAMD51N20A-AUT-EFP  
ATSAMD51N20A-AZ

ATSAMD51N20A-AZT  
ATSAMD51P19A-AF  
ATSAMD51P19A-AFT  
ATSAMD51P19A-AU  
ATSAMD51P19A-AU-EFP  
ATSAMD51P19A-AUN01  
ATSAMD51P19A-AUT  
ATSAMD51P19A-AUT-EFP  
ATSAMD51P19A-AZ  
ATSAMD51P19A-AZT  
ATSAMD51P19A-CTFT  
ATSAMD51P19A-CTUT  
ATSAMD51P19A-CTUT-EFP  
ATSAMD51P20A-AF  
ATSAMD51P20A-AFT  
ATSAMD51P20A-AU  
ATSAMD51P20A-AU-EFP  
ATSAMD51P20A-AUT  
ATSAMD51P20A-AUT-EFP  
ATSAMD51P20A-AZ  
ATSAMD51P20A-AZT  
ATSAMD51P20A-CTFT  
ATSAMD51P20A-CTUT  
ATSAMD51P20A-CTUT-EFP  
ATSAME51G18A-MF  
ATSAME51G18A-MFT  
ATSAME51G18A-MU  
ATSAME51G18A-MU-EFP  
ATSAME51G18A-MUT  
ATSAME51G18A-MUT-EFP  
ATSAME51G18A-MZ  
ATSAME51G18A-MZT  
ATSAME51G19A-MF  
ATSAME51G19A-MFT  
ATSAME51G19A-MU  
ATSAME51G19A-MU-EFP  
ATSAME51G19A-MUT  
ATSAME51G19A-MUT-EFP  
ATSAME51G19A-MZ  
ATSAME51G19A-MZT  
ATSAME51J18A-AF  
ATSAME51J18A-AFT  
ATSAME51J18A-AU  
ATSAME51J18A-AU-EFP  
ATSAME51J18A-AUT  
ATSAME51J18A-AUT-EFP  
ATSAME51J18A-AZ  
ATSAME51J18A-AZT  
ATSAME51J18A-MF

ATSAME51J18A-MFT  
ATSAME51J18A-MU  
ATSAME51J18A-MU-EFP  
ATSAME51J18A-MUT  
ATSAME51J18A-MUT-EFP  
ATSAME51J18A-MZ  
ATSAME51J18A-MZT  
ATSAME51J19A-AF  
ATSAME51J19A-AFT  
ATSAME51J19A-AU  
ATSAME51J19A-AU-EFP  
ATSAME51J19A-AUT  
ATSAME51J19A-AUT-EFP  
ATSAME51J19A-AZ  
ATSAME51J19A-AZT  
ATSAME51J19A-MF  
ATSAME51J19A-MFT  
ATSAME51J19A-MU  
ATSAME51J19A-MU-EFP  
ATSAME51J19A-MUT  
ATSAME51J19A-MUT-EFP  
ATSAME51J19A-MZ  
ATSAME51J19A-MZT  
ATSAME51J20A-AF  
ATSAME51J20A-AFT  
ATSAME51J20A-AU  
ATSAME51J20A-AU-EFP  
ATSAME51J20A-AUT  
ATSAME51J20A-AUT-EFP  
ATSAME51J20A-AZ  
ATSAME51J20A-AZT  
ATSAME51J20A-MF  
ATSAME51J20A-MFT  
ATSAME51J20A-MU  
ATSAME51J20A-MU-EFP  
ATSAME51J20A-MUT  
ATSAME51J20A-MUT-EFP  
ATSAME51J20A-MZ  
ATSAME51J20A-MZT  
ATSAME51J20A-MZV01  
ATSAME51N19A-AF  
ATSAME51N19A-AFT  
ATSAME51N19A-AU  
ATSAME51N19A-AU-EFP  
ATSAME51N19A-AUT  
ATSAME51N19A-AUT-EFP  
ATSAME51N19A-AZ  
ATSAME51N19A-AZT  
ATSAME51N20A-AF

ATSAME51N20A-AFT  
ATSAME51N20A-AU  
ATSAME51N20A-AU-EFP  
ATSAME51N20A-AUT  
ATSAME51N20A-AUT-EFP  
ATSAME51N20A-AZ  
ATSAME51N20A-AZT  
ATSAME51N20A-AZVAO  
ATSAME53J18A-AF  
ATSAME53J18A-AFT  
ATSAME53J18A-AU  
ATSAME53J18A-AU-EFP  
ATSAME53J18A-AUT  
ATSAME53J18A-AUT-EFP  
ATSAME53J18A-AZ  
ATSAME53J18A-AZT  
ATSAME53J18A-MF  
ATSAME53J18A-MFT  
ATSAME53J18A-MU  
ATSAME53J18A-MU-EFP  
ATSAME53J18A-MUN02  
ATSAME53J18A-MUT  
ATSAME53J18A-MUT-EFP  
ATSAME53J18A-MZ  
ATSAME53J18A-MZT  
ATSAME53J19A-AF  
ATSAME53J19A-AFT  
ATSAME53J19A-AU  
ATSAME53J19A-AU-EFP  
ATSAME53J19A-AUT  
ATSAME53J19A-AUT-EFP  
ATSAME53J19A-AZ  
ATSAME53J19A-AZT  
ATSAME53J19A-MF  
ATSAME53J19A-MFT  
ATSAME53J19A-MU  
ATSAME53J19A-MU-EFP  
ATSAME53J19A-MUT  
ATSAME53J19A-MUT-EFP  
ATSAME53J19A-MZ  
ATSAME53J19A-MZT  
ATSAME53J20A-AF  
ATSAME53J20A-AFT  
ATSAME53J20A-AU  
ATSAME53J20A-AU-EFP  
ATSAME53J20A-AUN03  
ATSAME53J20A-AUT  
ATSAME53J20A-AUT-EFP  
ATSAME53J20A-AZ

ATSAME53J20A-AZT  
ATSAME53J20A-MF  
ATSAME53J20A-MFT  
ATSAME53J20A-MU  
ATSAME53J20A-MU-EFP  
ATSAME53J20A-MUT  
ATSAME53J20A-MUT-EFP  
ATSAME53J20A-MZ  
ATSAME53J20A-MZT  
ATSAME53N19A-AF  
ATSAME53N19A-AFT  
ATSAME53N19A-AU  
ATSAME53N19A-AU-EFP  
ATSAME53N19A-AUT  
ATSAME53N19A-AUT-EFP  
ATSAME53N19A-AZ  
ATSAME53N19A-AZT  
ATSAME53N20A-AF  
ATSAME53N20A-AFT  
ATSAME53N20A-AU  
ATSAME53N20A-AU-EFP  
ATSAME53N20A-AUT  
ATSAME53N20A-AUT-EFP  
ATSAME53N20A-AZ  
ATSAME53N20A-AZT  
ATSAME54N19A-AF  
ATSAME54N19A-AFT  
ATSAME54N19A-AU  
ATSAME54N19A-AU-EFP  
ATSAME54N19A-AUT  
ATSAME54N19A-AUT-EFP  
ATSAME54N19A-AZ  
ATSAME54N19A-AZT  
ATSAME54N20A-AF  
ATSAME54N20A-AFT  
ATSAME54N20A-AU  
ATSAME54N20A-AU-EFP  
ATSAME54N20A-AUT  
ATSAME54N20A-AUT-EFP  
ATSAME54N20A-AZ  
ATSAME54N20A-AZT  
ATSAME54P19A-AF  
ATSAME54P19A-AFT  
ATSAME54P19A-AU  
ATSAME54P19A-AU-EFP  
ATSAME54P19A-AUT  
ATSAME54P19A-AUT-EFP  
ATSAME54P19A-AZ  
ATSAME54P19A-AZT

ATSAME54P19A-CTFT  
ATSAME54P19A-CTUT  
ATSAME54P19A-CTUT-EFP  
ATSAME54P20A-AF  
ATSAME54P20A-AFT  
ATSAME54P20A-AU  
ATSAME54P20A-AU-EFP  
ATSAME54P20A-AUT  
ATSAME54P20A-AUT-EFP  
ATSAME54P20A-AUTEK1  
ATSAME54P20A-AZ  
ATSAME54P20A-AZT  
ATSAME54P20A-CTFT  
ATSAME54P20A-CTUT  
ATSAME54P20A-CTUT-EFP





# SAM D5x/E5x Family Data Sheet

---

---

## 32-bit ARM<sup>®</sup> Cortex<sup>®</sup>-M4F MCUs with 1 Msp/s 12-bit ADC, QSPI, USB, Ethernet, and PTC

---

---

### Features

---

#### Operating Conditions:

- 1.71V to 3.63V, -40°C to +125°C, DC to 100 MHz
- 1.71V to 3.63V, -40°C to +105°C, DC to 120 MHz
- 1.71V to 3.63V, -40°C to +85°C, DC to 120 MHz

#### Core: 120 MHz Arm Cortex-M4

- 403 CoreMark<sup>®</sup> at 120 MHz
- 4 KB combined instruction cache and data cache
- 8-Zone Memory Protection Unit (MPU)
- Thumb<sup>®</sup>-2 instruction set
- Embedded Trace Module (ETM) with instruction trace stream
- Core Sight Embedded Trace Buffer (ETB)
- Trace Port Interface Unit (TPIU)
- Floating Point Unit (FPU)

#### Memories

- 1 MB/512 KB/256 KB in-system self-programmable Flash with:
  - Error Correction Code (ECC)
  - Dual bank with Read-While-Write (RWW) support
  - EEPROM hardware emulation
- 128 KB, 192 KB, 256 KB SRAM main memory
  - 64 KB, 96 KB, 128 KB of Error Correction Code (ECC) RAM option
- Up to 4 KB of Tightly Coupled Memory (TCM)
- Up to 8 KB additional SRAM
  - Can be retained in backup mode
- Eight 32-bit backup registers

#### System

- Power-on Reset (POR) and Brown-out detection (BOD)
- Internal and external clock options
- External Interrupt Controller (EIC)
- 16 external interrupts
- One non-maskable interrupt
- Two-pin Serial Wire Debug (SWD) programming, test, and debugging interface

#### Power Supply

- Idle, Standby, Hibernate, Backup, and Off sleep modes
- SleepWalking peripherals
- Battery backup support
- Embedded Buck/LDO regulator supporting on-the-fly selection

## High-Performance Peripherals

- 32-channel Direct Memory Access Controller (DMAC)
  - Built-in CRC with memory CRC generation/monitor hardware support
- Up to two SD/MMC Host Controller (SDHC)
  - Up to 50 MHz operation
  - 4-bit or 1-bit interface
  - Compatibility with SD and SDHC memory card specification version 3.01
  - Compatibility with SDIO specification version 3.0
  - Compliant with JDEC specification, MMC memory cards V4.51
- One Quad I/O Serial Peripheral Interface (QSPI)
  - eXecute-In-Place (XIP) support
  - Dedicated AHB memory zone
- One Ethernet MAC (SAM E53 and SAM E54)
  - 10/100 Mbps in MII and RMI with dedicated DMA
  - IEEE<sup>®</sup> 1588 Precision Time Protocol (PTP) support
  - IEEE 1588 Time Stamping Unit (TSU) support
  - IEEE802.3AZ energy efficiency support
  - Support for 802.1AS and 1588 precision clock synchronization protocol
  - Wake on LAN support
- Up to two Controller Area Network (CAN) (that is., SAM E51 and SAM E54)
  - Support for CAN 2.0A/CAN 2.0B and CAN-FD (ISO 11898-1:2016)
- One Full-Speed (12 Mbps) Universal Serial Bus (USB) 2.0 interface
  - Embedded host and device function
  - Eight endpoints
  - On-chip transceiver with integrated serial resistor

## System Peripherals

- 32-channel Event System
- Up to eight Serial Communication Interfaces (SERCOM), each configurable to operate as either:
  - USART with full-duplex and single-wire half-duplex configuration
  - ISO7816
  - I<sup>2</sup>C up to 3.4 MHz
  - SPI
  - LIN master/slave
  - RS485
  - SPI inter-byte space
- Up to eight 16-bit Timers/Counters (TC) each configurable as:
  - 16-bit TC with two compare/capture channels
  - 8-bit TC with two compare/capture channels

- 32-bit TC with two compare/capture channels, by pairing two TCs
- Two 24-bit Timer/Counters for Control (TCC), with extended functions:
  - Up to six compare channels with optional complementary output
  - Generation of synchronized pulse width modulation (PWM) pattern across port pins
  - Deterministic fault protection, fast decay and configurable dead-time between complementary output
  - Dithering that increase resolution with up to 5 bit and reduce quantization error
- Up to Three 16-bit Timer/Counters for Control (TCC) with extended functions:
  - Up to three compare channels with optional complementary output
- 32-bit Real Time Counter (RTC) with clock/calendar function
- Up to 4 wake-up pins with tamper detection and debouncing filter
- Watchdog Timer (WDT) with Window mode
- CRC-32 generator
- One two-channel Inter-IC Sound Interface (I<sup>2</sup>S)
- Position Decoder (PDEC)
- Frequency meter (FREQM)
- Four Configurable Custom Logic (CCL)
- Dual 12-bit, 1 MSPS Analog-to-Digital Converter (ADC) with up to 16 channels each:
  - Differential and single-ended input
  - Automatic offset and gain error compensation
  - Oversampling and decimation in hardware to support 13-bit, 14-bit, 15-bit, or 16-bit resolution
- Dual 12-bit, 1 MSPS output Digital-to-Analog Converter (DAC)
- Two Analog Comparators (AC) with Window Compare function
- One temperature sensor
- Parallel Capture Controller (PCC)
  - Up to 14-bit parallel capture mode
- Peripheral Touch Controller (PTC)
  - Capacitive Touch buttons, sliders, and wheels
  - Wake-up on touch
  - Up to 32 self-capacitance and up to 256 mutual-capacitance channels

## Cryptography

- One Advanced Encryption System (AES) with 256-bit key length and up to 2 MB/s data rate
  - Five confidential modes of operation (ECB, CBC, CFB, OFB, CTR)
  - Supports counter with CBC-MAC mode
  - Galois Counter Mode (GCM)
- True Random Number Generator (TRNG)
- Public Key Cryptography Controller (PUKCC) and associated Classical Public Key Cryptography Library (PUKCL)
  - RSA, DSA
  - Elliptic Curves Cryptography (ECC) ECC GF(2<sup>n</sup>), ECC GF(p)
- Integrity Check Module (ICM) based on Secure Hash Algorithm (SHA1, SHA224, SHA256), DMA assisted

## Oscillators

# SAM D5x/E5x Family Data Sheet

- 32.768 kHz crystal oscillator (XOSC32K)
  - Clock failure detection
- Up to two 8 MHz to 48 MHz crystal oscillator (XOSC)
  - Clock failure detection
- 32.768 kHz ultra low-power internal oscillator (OSCULP32K)
- 48 MHz Digital Frequency Locked Loop (DFLL48M)
- Two 96-200 MHz Fractional Digital Phased Locked Loop (FDPLL200M)

## I/O

- Up to 99 programmable I/O pins

## Qualification

- AEC-Q100 Grade 1 (-40°C to 125°C)

## Packages

**Table 1. Package Types**

Parameter	Package Type						
	VQFN		TQFP			TFBGA	WLCSP
Pin Count	48	64	64	100	128	120	64
I/O Pins (up to)	37	51	51	81	99	90	51
Contact/Lead Pitch	0.5	0.5	0.5	0.5	0.4	0.5	0.4
Dimension	7x7x0.9	9x9x0.9	10x10x1.2	14x14x1.2	14x14x1.2	8x8x1.2	3.59x3.51x0.53

**Note:** All dimensions are in millimeter (mm) unless specified.

## Table of Contents

Features.....	1
1. Configuration Summary.....	17
2. Ordering Information.....	19
3. Block Diagram.....	20
3.1. SAM D5x/E5x Block Diagram.....	20
4. Pinout.....	22
4.1. 48-Pin VQFN Package.....	22
4.2. 64-Pin TQFP and VQFN Package.....	23
4.3. 64-Pin WLCSP Package.....	24
4.4. 100-Pin TQFP Package.....	25
4.5. 120-ball TFBGA Package.....	26
4.6. 128-Pin TQFP Package.....	27
5. Signal Descriptions List.....	28
6. I/O Multiplexing and Considerations.....	32
6.1. Multiplexed Signals.....	32
6.2. Other Functions.....	36
7. Power Supply and Start-Up Considerations.....	47
7.1. Power Domain Overview.....	47
7.2. Power Supply Considerations.....	47
7.3. Power-Up.....	49
7.4. Power-On Reset and Brown-Out Detector.....	50
8. Product Memory Mapping Overview.....	52
9. Memories.....	54
9.1. Embedded Memories.....	54
9.2. Physical Memory Map.....	54
9.3. SRAM Memory Configuration.....	55
9.4. NVM User Page Mapping.....	57
9.5. NVM Software Calibration Area Mapping.....	59
9.6. Serial Number.....	60
10. Processor and Architecture.....	61
10.1. Cortex M4 Processor.....	61
10.2. Nested Vector Interrupt Controller.....	64
10.3. High-Speed Bus System.....	77
11. CMCC - Cortex M Cache Controller.....	81
11.1. Overview.....	81

11.2. Features.....	81
11.3. Block Diagram.....	82
11.4. Signal Description.....	83
11.5. Product Dependencies.....	83
11.6. Functional Description.....	83
11.7. DEBUG Mode.....	86
11.8. RAM Properties.....	87
11.9. Register Summary.....	88
11.10. Register Description.....	89
<b>12. DSU - Device Service Unit.....</b>	<b>103</b>
12.1. Overview.....	103
12.2. Features.....	103
12.3. Block Diagram.....	104
12.4. Signal Description.....	104
12.5. Product Dependencies.....	104
12.6. Debug Operation.....	105
12.7. Chip Erase.....	107
12.8. Programming.....	108
12.9. Intellectual Property Protection.....	108
12.10. Device Identification.....	110
12.11. Functional Description.....	111
12.12. Register Summary.....	116
12.13. Register Description.....	118
<b>13. Clock System.....</b>	<b>145</b>
13.1. Clock Distribution.....	145
13.2. Synchronous and Asynchronous Clocks.....	147
13.3. Register Synchronization.....	147
13.4. Enabling a Peripheral.....	150
13.5. On Demand Clock Requests.....	150
13.6. Power Consumption vs. Speed.....	151
13.7. Clocks after Reset.....	151
<b>14. GCLK - Generic Clock Controller.....</b>	<b>152</b>
14.1. Overview.....	152
14.2. Features.....	152
14.3. Block Diagram.....	152
14.4. Signal Description.....	153
14.5. Product Dependencies.....	153
14.6. Functional Description.....	154
14.7. Register Summary.....	160
14.8. Register Description.....	160
<b>15. MCLK – Main Clock.....</b>	<b>170</b>
15.1. Overview.....	170
15.2. Features.....	170
15.3. Block Diagram.....	170

15.4. Signal Description.....	170
15.5. Product Dependencies.....	170
15.6. Functional Description.....	172
15.7. Register Summary.....	178
15.8. Register Description.....	178
<b>16. RSTC – Reset Controller.....</b>	<b>196</b>
16.1. Overview.....	196
16.2. Features.....	196
16.3. Block Diagram.....	196
16.4. Signal Description.....	196
16.5. Product Dependencies.....	197
16.6. Functional Description.....	197
16.7. Register Summary.....	200
16.8. Register Description.....	200
<b>17. RAMECC – RAM Error Correction Code (ECC).....</b>	<b>203</b>
17.1. Overview.....	203
17.2. Features.....	203
17.3. Block Diagram.....	203
17.4. Signal Description.....	203
17.5. Product Dependencies.....	203
17.6. Functional Description.....	205
17.7. Register Summary.....	207
17.8. Register Description.....	207
<b>18. PM – Power Manager.....</b>	<b>214</b>
18.1. Overview.....	214
18.2. Features.....	214
18.3. Block Diagram.....	214
18.4. Signal Description.....	214
18.5. Product Dependencies.....	214
18.6. Functional Description.....	216
18.7. Register Summary.....	225
18.8. Register Description.....	225
<b>19. SUPC – Supply Controller.....</b>	<b>235</b>
19.1. Overview.....	235
19.2. Features.....	235
19.3. Block Diagram.....	236
19.4. Signal Description.....	236
19.5. Product Dependencies.....	236
19.6. Functional Description.....	238
19.7. Register Summary.....	245
19.8. Register Description.....	246
<b>20. WDT – Watchdog Timer.....</b>	<b>265</b>
20.1. Overview.....	265

20.2. Features.....	265
20.3. Block Diagram.....	266
20.4. Signal Description.....	266
20.5. Product Dependencies.....	266
20.6. Functional Description.....	267
20.7. Register Summary.....	273
20.8. Register Description.....	273
<b>21. RTC – Real-Time Counter.....</b>	<b>283</b>
21.1. Overview.....	283
21.2. Features.....	283
21.3. Block Diagram.....	284
21.4. Signal Description.....	285
21.5. Product Dependencies.....	285
21.6. Functional Description.....	286
21.7. Register Summary - Mode 0 - 32-Bit Counter.....	299
21.8. Register Description - Mode 0 - 32-Bit Counter.....	301
21.9. Register Summary - Mode 1 - 16-Bit Counter.....	323
21.10. Register Description - Mode 1 - 16-Bit Counter.....	325
21.11. Register Summary - Mode 2 - Clock/Calendar.....	348
21.12. Register Description - Mode 2 - Clock/Calendar.....	350
<b>22. DMAC – Direct Memory Access Controller.....</b>	<b>374</b>
22.1. Overview.....	374
22.2. Features.....	374
22.3. Block Diagram.....	376
22.4. Signal Description.....	376
22.5. Product Dependencies.....	376
22.6. Functional Description.....	377
22.7. Register Summary.....	402
22.8. Register Description.....	414
22.9. Register Summary - SRAM.....	443
22.10. Register Description - SRAM.....	443
<b>23. EIC – External Interrupt Controller.....</b>	<b>451</b>
23.1. Overview.....	451
23.2. Features.....	451
23.3. Block Diagram.....	451
23.4. Signal Description.....	452
23.5. Product Dependencies.....	452
23.6. Functional Description.....	453
23.7. Register Summary.....	461
23.8. Register Description.....	462
<b>24. GMAC - Ethernet MAC.....</b>	<b>477</b>
24.1. Description.....	477
24.2. Features.....	477
24.3. Block Diagram.....	478



24.4. Signal Description.....	478
24.5. Product Dependencies.....	479
24.6. Functional Description.....	480
24.7. Programming Interface.....	507
24.8. Register Summary.....	512
24.9. Register Description.....	522
<b>25. NVMCTRL – Nonvolatile Memory Controller.....</b>	<b>639</b>
25.1. Overview.....	639
25.2. Features.....	639
25.3. Block Diagram.....	640
25.4. Signal Description.....	640
25.5. Product Dependencies.....	640
25.6. Functional Description.....	642
25.7. Register Summary.....	662
25.8. Register Description.....	663
<b>26. ICM - Integrity Check Monitor.....</b>	<b>686</b>
26.1. Overview.....	686
26.2. Features.....	686
26.3. Block Diagram.....	687
26.4. Signal Description.....	687
26.5. Product Dependencies.....	687
26.6. Functional Description.....	688
26.7. Register Summary - ICM.....	703
26.8. Register Description.....	704
<b>27. PAC - Peripheral Access Controller.....</b>	<b>725</b>
27.1. Overview.....	725
27.2. Features.....	725
27.3. Block Diagram.....	725
27.4. Product Dependencies.....	725
27.5. Functional Description.....	727
27.6. Register Summary.....	730
27.7. Register Description.....	731
<b>28. OSCCTRL – Oscillators Controller.....</b>	<b>763</b>
28.1. Overview.....	763
28.2. Features.....	763
28.3. Block Diagram.....	764
28.4. Signal Description.....	764
28.5. Product Dependencies.....	764
28.6. Functional Description.....	765
28.7. Register Summary.....	779
28.8. Register Description.....	781
<b>29. OSC32KCTRL – 32KHz Oscillators Controller.....</b>	<b>811</b>
29.1. Overview.....	811

29.2. Features.....	811
29.3. Block Diagram.....	812
29.4. Signal Description.....	812
29.5. Product Dependencies.....	812
29.6. Functional Description.....	814
29.7. Register Summary.....	819
29.8. Register Description.....	819
<b>30. FREQM – Frequency Meter.....</b>	<b>831</b>
30.1. Overview.....	831
30.2. Features.....	831
30.3. Block Diagram.....	831
30.4. Signal Description.....	831
30.5. Product Dependencies.....	831
30.6. Functional Description.....	833
30.7. Register Summary.....	836
30.8. Register Description.....	836
<b>31. EVSYS – Event System.....</b>	<b>846</b>
31.1. Overview.....	846
31.2. Features.....	846
31.3. Block Diagram.....	847
31.4. Product Dependencies.....	847
31.5. Functional Description.....	848
31.6. Register Summary.....	856
31.7. Register Description.....	862
<b>32. PORT - I/O Pin Controller.....</b>	<b>883</b>
32.1. Overview.....	883
32.2. Features.....	883
32.3. Block Diagram.....	884
32.4. Signal Description.....	884
32.5. Product Dependencies.....	884
32.6. Functional Description.....	886
32.7. Register Summary.....	892
32.8. Register Description.....	893
<b>33. SERCOM – Serial Communication Interface.....</b>	<b>913</b>
33.1. Overview.....	913
33.2. Features.....	913
33.3. Block Diagram.....	914
33.4. Signal Description.....	914
33.5. Product Dependencies.....	914
33.6. Functional Description.....	916
<b>34. SERCOM USART - SERCOM Synchronous and Asynchronous Receiver and Transmitter.....</b>	<b>922</b>
34.1. Overview.....	922

34.2.	USART Features.....	922
34.3.	Block Diagram.....	923
34.4.	Signal Description.....	923
34.5.	Product Dependencies.....	923
34.6.	Functional Description.....	925
34.7.	Register Summary.....	942
34.8.	Register Description.....	943
35.	SERCOM SPI – SERCOM Serial Peripheral Interface.....	969
35.1.	Overview.....	969
35.2.	Features.....	969
35.3.	Block Diagram.....	970
35.4.	Signal Description.....	970
35.5.	Product Dependencies.....	970
35.6.	Functional Description.....	972
35.7.	Register Summary.....	983
35.8.	Register Description.....	984
36.	SERCOM I <sup>2</sup> C – Inter-Integrated Circuit.....	1005
36.1.	Overview.....	1005
36.2.	Features.....	1005
36.3.	Block Diagram.....	1006
36.4.	Signal Description.....	1006
36.5.	Product Dependencies.....	1006
36.6.	Functional Description.....	1008
36.7.	Register Summary - I2C Slave.....	1028
36.8.	Register Description - I <sup>2</sup> C Slave.....	1029
36.9.	Register Summary - I2C Master.....	1047
36.10.	Register Description - I <sup>2</sup> C Master.....	1048
37.	QSPI - Quad Serial Peripheral Interface.....	1066
37.1.	Overview.....	1066
37.2.	Features.....	1066
37.3.	Block Diagram.....	1067
37.4.	Signal Description.....	1067
37.5.	Product Dependencies.....	1067
37.6.	Functional Description.....	1069
37.7.	Register Summary.....	1086
37.8.	Register Description.....	1087
38.	USB – Universal Serial Bus.....	1109
38.1.	Overview.....	1109
38.2.	Features.....	1109
38.3.	USB Block Diagram.....	1110
38.4.	Signal Description.....	1110
38.5.	Product Dependencies.....	1110
38.6.	Functional Description.....	1112
38.7.	Register Summary.....	1132

38.8. Register Description.....	1136
<b>39. CAN - Control Area Network.....</b>	<b>1204</b>
39.1. Overview.....	1204
39.2. Features.....	1204
39.3. Block Diagram.....	1205
39.4. Signal Description.....	1205
39.5. Product Dependencies.....	1205
39.6. Functional Description.....	1206
39.7. Register Summary.....	1228
39.8. Register Description.....	1232
39.9. Message RAM.....	1301
<b>40. SD/MMC Host Controller (SDHC).....</b>	<b>1311</b>
40.1. Overview.....	1311
40.2. Features.....	1311
40.3. Block Diagrams.....	1312
40.4. Signal Description.....	1313
40.5. Product Dependencies.....	1313
40.6. Functional Description.....	1314
40.7. Register Summary.....	1315
40.8. Register Description.....	1318
<b>41. CCL – Configurable Custom Logic.....</b>	<b>1393</b>
41.1. Overview.....	1393
41.2. Features.....	1393
41.3. Block Diagram.....	1394
41.4. Signal Description.....	1394
41.5. Product Dependencies.....	1394
41.6. Functional Description.....	1396
41.7. Register Summary.....	1407
41.8. Register Description.....	1407
<b>42. AES – Advanced Encryption Standard.....</b>	<b>1412</b>
42.1. Overview.....	1412
42.2. Features.....	1412
42.3. Block Diagram.....	1413
42.4. Signal Description.....	1414
42.5. Product Dependencies.....	1414
42.6. Functional Description.....	1415
42.7. Register Summary.....	1424
42.8. Register Description.....	1426
<b>43. Public Key Cryptography Controller (PUKCC).....</b>	<b>1443</b>
43.1. Overview.....	1443
43.2. Product Dependencies.....	1443
43.3. Functional Description.....	1444

44. TRNG – True Random Number Generator.....	1574
44.1. Overview.....	1574
44.2. Features.....	1574
44.3. Block Diagram.....	1574
44.4. Signal Description.....	1574
44.5. Product Dependencies.....	1574
44.6. Functional Description.....	1576
44.7. Register Summary.....	1578
44.8. Register Description.....	1578
45. ADC – Analog-to-Digital Converter.....	1585
45.1. Overview.....	1585
45.2. Features.....	1585
45.3. Block Diagram.....	1586
45.4. Signal Description.....	1586
45.5. Product Dependencies.....	1587
45.6. Functional Description.....	1588
45.7. Register Summary.....	1606
45.8. Register Description.....	1607
46. AC – Analog Comparators.....	1640
46.1. Overview.....	1640
46.2. Features.....	1640
46.3. Block Diagram.....	1641
46.4. Signal Description.....	1641
46.5. Product Dependencies.....	1641
46.6. Functional Description.....	1643
46.7. Register Summary.....	1653
46.8. Register Description.....	1653
47. DAC – Digital-to-Analog Converter.....	1671
47.1. Overview.....	1671
47.2. Features.....	1671
47.3. Block Diagram.....	1671
47.4. Signal Description.....	1671
47.5. Product Dependencies.....	1672
47.6. Functional Description.....	1674
47.7. Register Summary.....	1684
47.8. Register Description.....	1684
48. TC – Timer/Counter.....	1710
48.1. Overview.....	1710
48.2. Features.....	1710
48.3. Block Diagram.....	1711
48.4. Signal Description.....	1711
48.5. Product Dependencies.....	1712
48.6. Functional Description.....	1713

48.7. Register Description.....	1729
<b>49. TCC – Timer/Counter for Control Applications.....</b>	<b>1799</b>
49.1. Overview.....	1799
49.2. Features.....	1799
49.3. Block Diagram.....	1800
49.4. Signal Description.....	1800
49.5. Product Dependencies.....	1801
49.6. Functional Description.....	1802
49.7. Register Summary.....	1838
49.8. Register Description.....	1841
<b>50. PTC - Peripheral Touch Controller.....</b>	<b>1884</b>
50.1. Overview.....	1884
50.2. Features.....	1884
50.3. Block Diagram.....	1885
50.4. Signal Description.....	1885
50.5. System Dependencies.....	1886
50.6. Functional Description.....	1887
<b>51. I2S - Inter-IC Sound Controller.....</b>	<b>1888</b>
51.1. Overview.....	1888
51.2. Features.....	1888
51.3. Block Diagram.....	1889
51.4. Signal Description.....	1889
51.5. Product Dependencies.....	1890
51.6. Functional Description.....	1891
51.7. I <sup>2</sup> S Application Examples.....	1902
51.8. Register Summary.....	1905
51.9. Register Description.....	1906
<b>52. PCC - Parallel Capture Controller.....</b>	<b>1925</b>
52.1. Overview.....	1925
52.2. Features.....	1925
52.3. Block Diagram.....	1925
52.4. Signal Description.....	1925
52.5. Product Dependencies.....	1926
52.6. Functional Description.....	1927
52.7. Register Summary.....	1934
52.8. Register Description.....	1934
<b>53. PDEC – Position Decoder.....</b>	<b>1946</b>
53.1. Overview.....	1946
53.2. Features.....	1946
53.3. Block Diagram.....	1947
53.4. Signal Description.....	1947
53.5. Product Dependencies.....	1947
53.6. Functional Description.....	1949

# SAM D5x/E5x Family Data Sheet

53.7. Register Summary.....	1959
53.8. Register Description.....	1960
<b>54. Electrical Characteristics at 85°C.....</b>	<b>1986</b>
54.1. Disclaimer.....	1986
54.2. Absolute Maximum Ratings.....	1986
54.3. General Operating Ratings.....	1986
54.4. Injection Current.....	1987
54.5. Supply Characteristics.....	1988
54.6. Maximum Clock Frequencies.....	1989
54.7. Power Consumption.....	1990
54.8. Wake-Up Time.....	1994
54.9. I/O Pin Characteristics.....	1995
54.10. Analog Characteristics.....	1996
54.11. PTC Characteristics.....	2009
54.12. NVM Characteristics.....	2011
54.13. Oscillators Characteristics.....	2012
54.14. Timing Characteristics.....	2019
54.15. USB Characteristics.....	2033
<b>55. Electrical Characteristics at 105°C.....</b>	<b>2035</b>
55.1. General Operating Ratings (105°C).....	2035
55.2. Supply Characteristics (105°C).....	2035
55.3. Power Consumption (105°C).....	2035
55.4. Analog Characteristics (105°C).....	2039
55.5. NVM Characteristics.....	2049
55.6. Oscillators Characteristics (105°C).....	2050
<b>56. Electrical Characteristics at 125°C.....</b>	<b>2053</b>
56.1. General Operating Ratings (125°C).....	2053
56.2. Injection Current (125°C).....	2053
56.3. Supply Characteristics (125°C).....	2054
56.4. Maximum Clock Frequencies (125°C).....	2054
56.5. Power Consumption (125°C).....	2055
56.6. Analog Characteristics (125°C).....	2059
56.7. NVM Characteristics (125°C).....	2068
56.8. Oscillators Characteristics (125°C).....	2069
56.9. Timing Characteristics (125°C).....	2071
<b>57. AEC Q-100 Grade 1, 125°C Electrical Characteristics.....</b>	<b>2072</b>
<b>58. Packaging Information.....</b>	<b>2073</b>
58.1. Package Marking Information.....	2073
58.2. Thermal Considerations.....	2073
58.3. Package Drawings.....	2074
58.4. Soldering Profile.....	2095
<b>59. Schematic Checklist.....</b>	<b>2096</b>

59.1. Introduction.....	2096
59.2. Power Supply.....	2096
59.3. External Analog Reference Connections.....	2098
59.4. External Reset Circuit.....	2101
59.5. Unused or Unconnected Pins.....	2102
59.6. Clocks and Crystal Oscillators.....	2102
59.7. Programming and Debug Ports.....	2105
59.8. QSPI Interface.....	2109
59.9. USB Interface.....	2109
59.10. SDHC Interface.....	2111
60. Conventions.....	2112
60.1. Numerical Notation.....	2112
60.2. Memory Size and Type.....	2112
60.3. Frequency and Time.....	2112
60.4. Registers and Bits.....	2113
61. Acronyms and Abbreviations.....	2115
62. Revision History.....	2118
The Microchip Web Site.....	2125
Customer Change Notification Service.....	2125
Customer Support.....	2125
Product Identification System.....	2126
Microchip Devices Code Protection Feature.....	2126
Legal Notice.....	2126
Trademarks.....	2127
Quality Management System Certified by DNV.....	2127
Worldwide Sales and Service.....	2129



# SAM D5x/E5x Family Data Sheet

## Configuration Summary

### 1. Configuration Summary

**Table 1-1. SAM E53/E54 Family Features with Ethernet**

Device	Program Memory (KB)	Data Memory (KB)	Pins	Packages	Ethernet Controller	Peripherals														Analog				Security												
						CAN-FD	SERCOM	TC/Compare	TCC (24-bit/16-bit)	I2S	USB	QSPI	SDHC	DMA Channels	PCC (data size)	CCL	Position Decoder	RTC	WDT	Frequency Measurement	Event System (Channels)	External Interrupt Lines	I/O Pins	ADC (Channels ADC0/ADC1)	Analog Comparators (Channels)	DAC (Channels)	PTC (Mutual/Self-capacitance Channels)	Temperature Sensor	AES	TRNG	Public Key Cryptography (PUKCC)	Integrity Check Monitor	Tamper Pins			
SAME53N20	1024	256	100	TQFP			8	8/2					2		14								81	16/12										5		
SAME53N19	512	192							N																											
SAME53J20	1024	256	64	TQFP, VQFN																																
SAME53J19	512	192							6	6/2					1		10								51	16/8										3
SAME53J18	256	128																																		
SAME54P20	1024	256	128	TQFP	Y				2/3	Y	Y	Y		32		4	Y	Y	Y	Y	32	16			4	2	256/32	Y	Y	Y	Y	Y				
			120	TFBGA																																
SAME54P19	512	192	128	TQFP		Y	8	8/2					2		14								99	16/16										5		
			120	TFBGA																																
SAME54N20	1024	256	100	TQFP																																
SAME54N19	512	192																																		

# SAM D5x/E5x Family Data Sheet

## Configuration Summary

**Table 1-2. SAM D51/E51 Family Features without Ethernet**

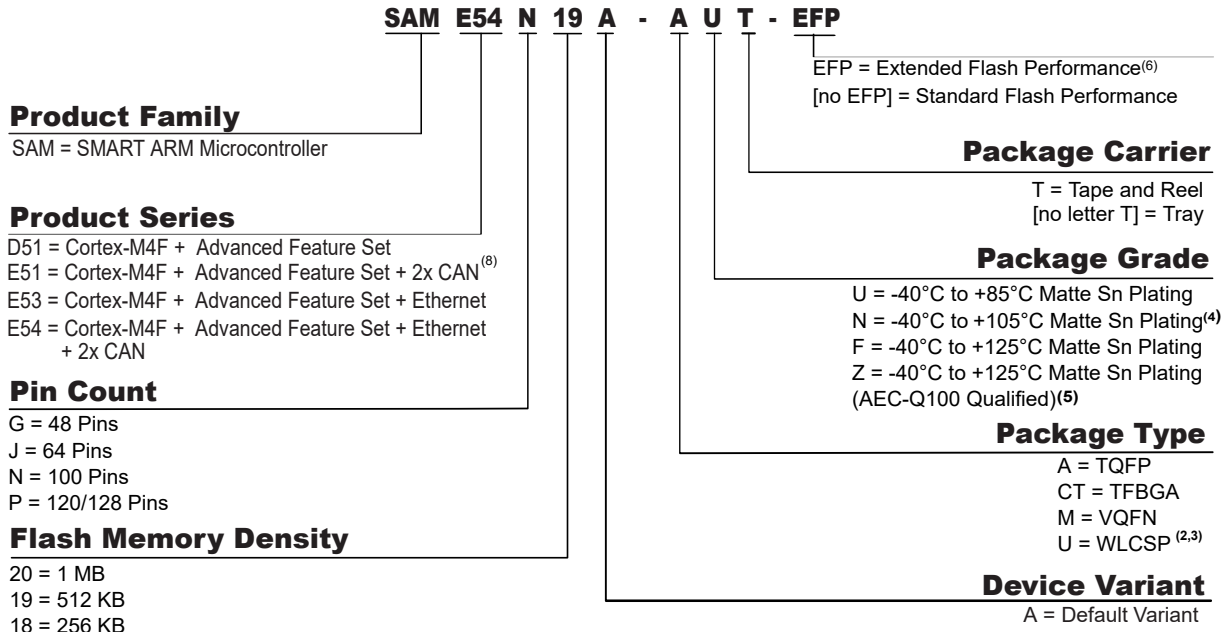
Device	Program Memory (KB)	Data Memory (KB)	Pins	Packages	Peripherals																Analog			Security																											
					CAN-FD	SERCOM	TC/Compare	TCC (24-bit/16-bit)	I2S	USB	QSPI	SDHC	DMA Channels	PCC (data size)	CCL	Position Decoder	RTC	Frequency Measurement	Event System (Channels)	External Interrupt Lines	I/O Pins	ADC (Channels ADC0/ADC1)	Analog Comparators (Channels)	DAC (Channels)	PTC (Mutual/Self-capacitance Channels)	Temperature Sensor	AES	TRNG	Public Key Cryptography (PUKCC)	Integrity Check Monitor	Tamper Pins																				
SAMD51P20	1024	256	128	TQFP	N	8	8/2	2/3	Y	Y	Y	Y	Y	Y	Y	Y	Y	99	16/16	4	2	Y	Y	Y	Y	Y	Y																								
			120	TFBGA																								6	4/2	2/1	N	1	10	37	16/4	121/22	2														
SAMD51P19	512	192	128	TQFP																																		6	4/2	2/1	N	1	10	37	16/4	121/22	2				
			120	TFBGA																								6	4/2	2/1	N	1	10	37	16/4	121/22	2														
SAMD51N20	1024	256	100	TQFP																																		6	4/2	2/1	N	Y	Y	Y	Y	Y	Y	Y	Y	81	16/12
SAMD51N19	512	192	100	TQFP																								6	4/2	2/1	N	Y	Y	Y	Y	Y	Y														
SAMD51J20	1024	256	64	TQFP, VQFN, WLCSP																																		6	4/2	2/1	N	Y	Y	Y	Y	Y	Y	Y	Y	Y	51
SAMD51J19	512	192	64	TQFP, VQFN, WLCSP																								6	4/2	2/1	N	Y	Y	Y	Y	Y	Y														
SAMD51J18	256	128	64	TQFP, VQFN																																		6	4/2	2/1	N	Y	Y	Y	Y	Y	Y	Y	Y	Y	51
SAMD51G19	512	192	48	VQFN																								6	4/2	2/1	N	Y	Y	Y	Y	Y	Y														
SAMD51G18	256	128	48	VQFN																																		6	4/2	2/1	N	Y	Y	Y	Y	Y	Y	Y	Y	Y	37
SAME51N20	1024	256	100	TQFP																								6	4/2	2/1	N	Y	Y	Y	Y	Y	Y														
SAME51N19	512	192	100	TQFP																																		6	4/2	2/1	N	Y	Y	Y	Y	Y	Y	Y	Y	Y	81
SAME51J20	1024	256	64	TQFP, VQFN																								6	4/2	2/1	Y	Y	Y	Y	Y	Y	Y														
SAME51J19	512	192	64	TQFP, VQFN																																		6	4/2	2/1	Y	Y	Y	Y	Y	Y	Y	Y	Y	Y	51
SAME51J18	256	128	64	TQFP, VQFN																								6	4/2	2/1	Y	Y	Y	Y	Y	Y	Y														
SAME51G18	256	128	48	VQFN	6	4/2	2/1	Y	Y	Y	Y	Y	Y	Y	Y	Y	Y	51	16/8	4	2	Y	Y	Y	Y	Y	Y											Y													
SAME51G19	512	192	48	VQFN																								6	4/2	2/1	Y	Y	Y	Y	Y	Y	Y		Y	Y	Y	37	16/4	4	2	Y	Y	Y	Y	Y	Y

**Related Links**

- [6.2.6 SERCOM I2C Configurations](#)
- [6.2.9 GPIO Clusters](#)

## 2. Ordering Information

Figure 2-1. Composition of the Ordering Numbers<sup>(1)</sup>



**Note:**

1. Not all combinations are valid. The available device part numbers are listed in [Configuration Summary](#).
2. Devices in the WLCSP package include a factory programmed Bootloader. Contact your local Microchip sales office for additional information.
3. WLCSP package type is available only with the package Grade **U** and **N**.
4. Package Grade **N** is available with only package type **U**.
5. The AEC-Q100 Grade 1 qualified version is only offered in the TQFP and VQFN packages. The VQFN package will have wettable flanks, and both TQFP and VQFN packages are assembled with gold bond wires.
6. EFP is only available for package Grade **U**.
7. EFP is an ordering code extension and will not be printed onto the package marking (section 58.1: Package Marking Information).
8. E51G devices have only 1 instance of CAN.

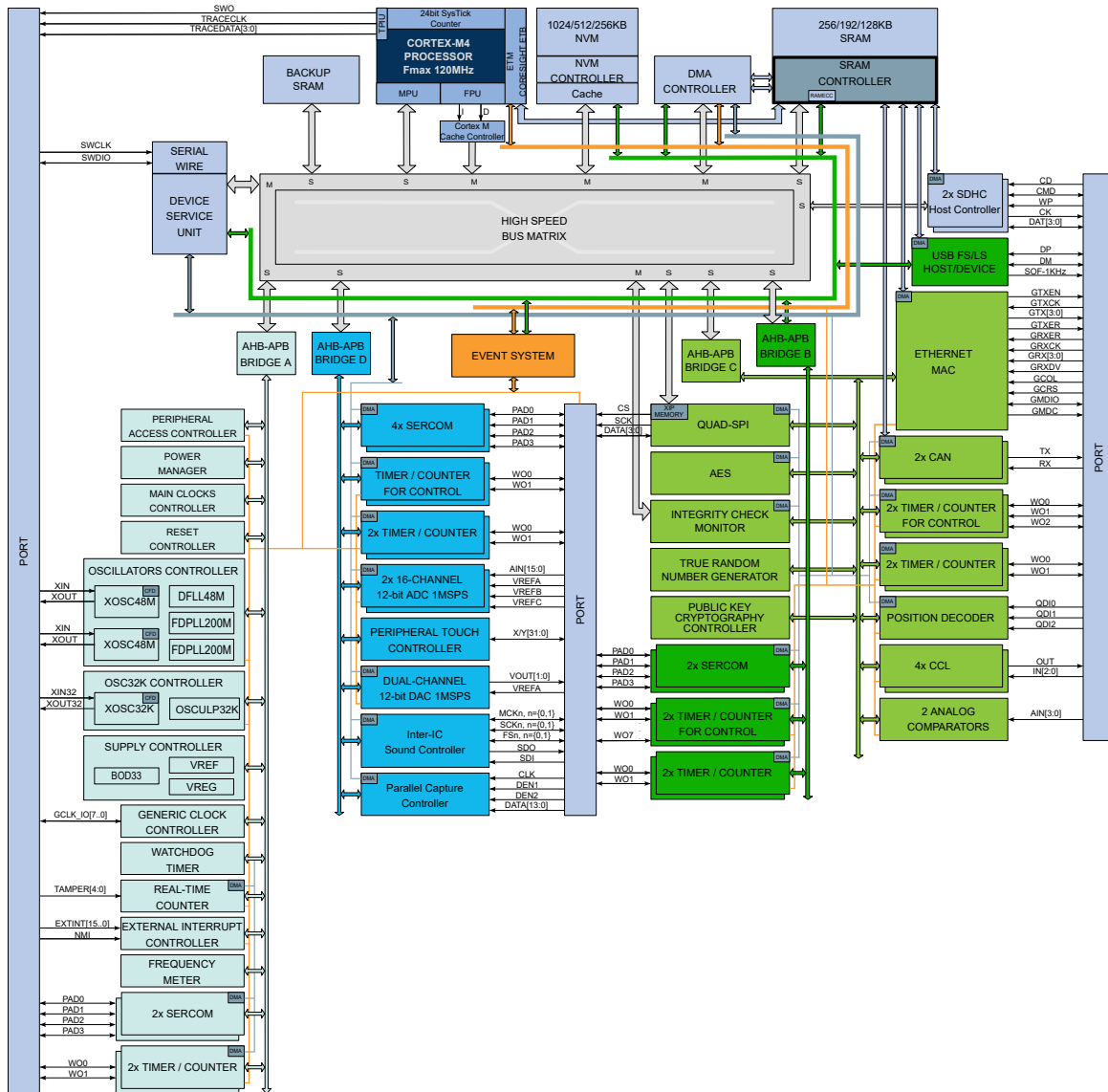
# SAM D5x/E5x Family Data Sheet

## Block Diagram

### 3. Block Diagram

The actual configuration may vary with device memory and number of pins. Refer to the Configuration Summary for details.

#### 3.1 SAM D5x/E5x Block Diagram



**Note:**

1. Some products have different number of SERCOM instances, Timer/Counter instances, PTC signals and ADC signals.
2. The block diagram is representing SAM E54P. Refer to the Configuration Summary for the configuration of a given device.

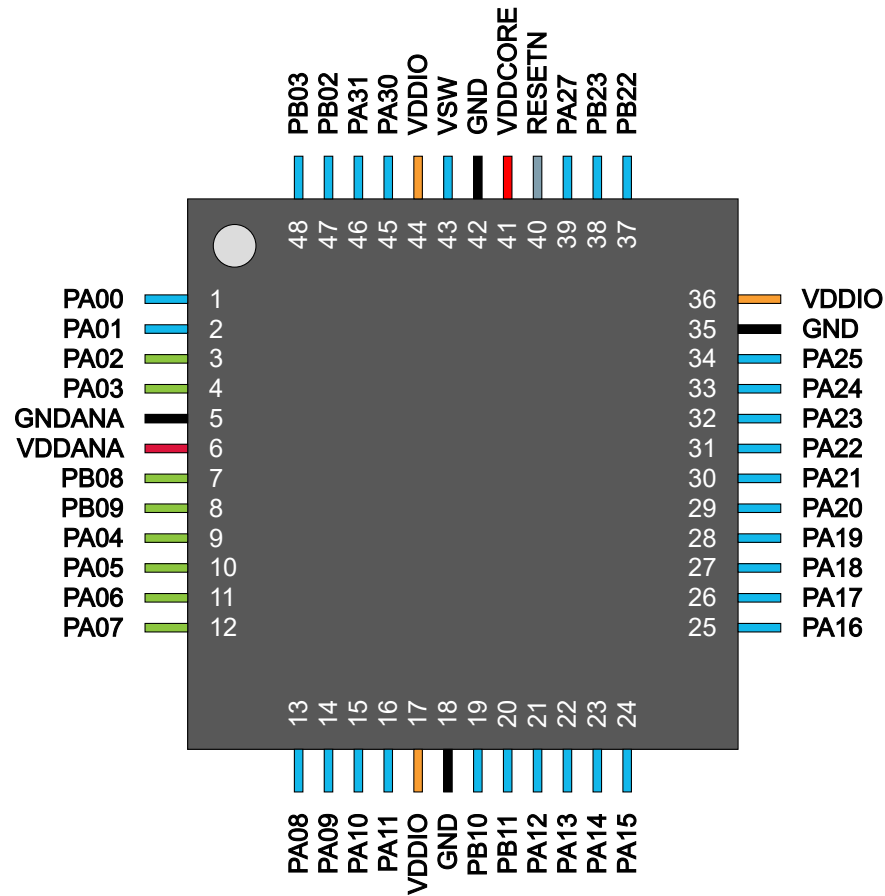
### Related Links

- [1. Configuration Summary](#)

### 4. Pinout

#### 4.1 48-Pin VQFN Package

Figure 4-1. 48-Pin VQFN<sup>(1)</sup> Package

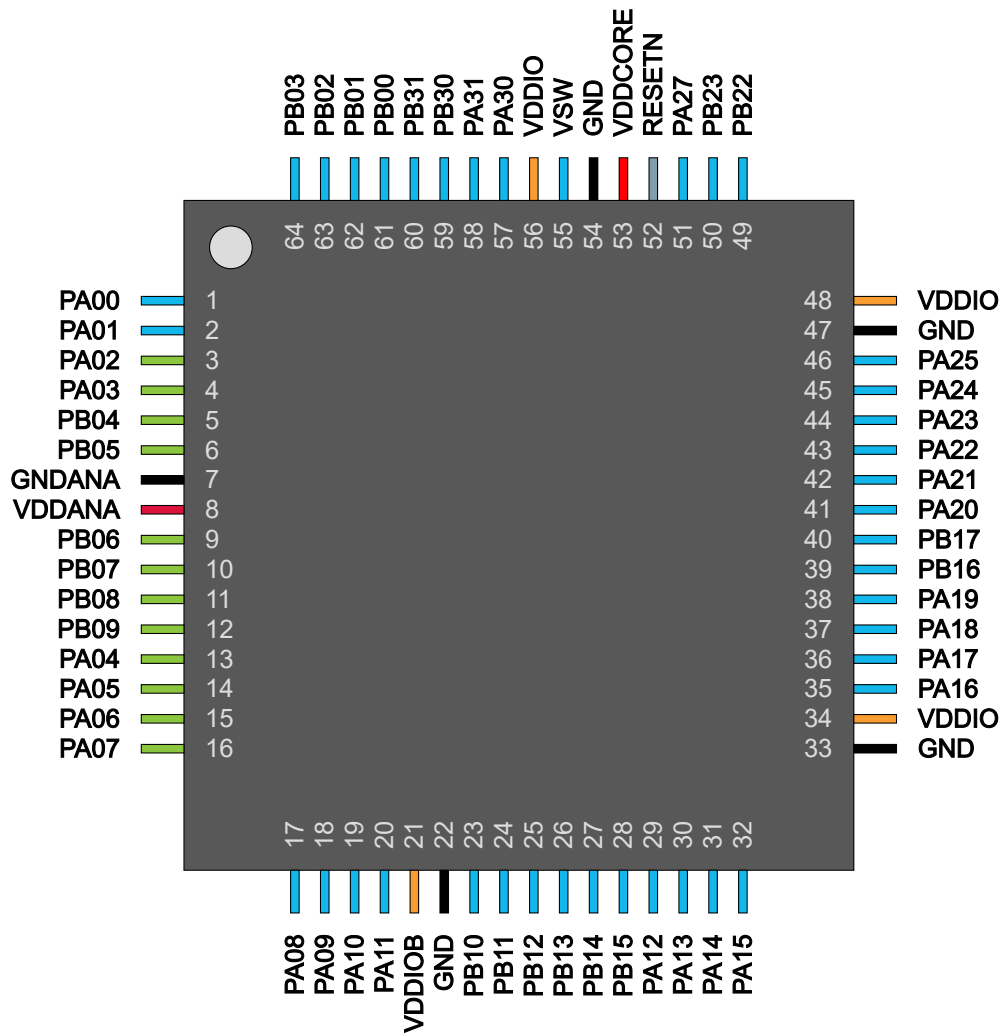


**Note:**

1. It is recommended that the exposed pad be connected to ground in the PCB. Refer to the section [58.3 Package Drawings](#) for further information.

### 4.2 64-Pin TQFP and VQFN Package

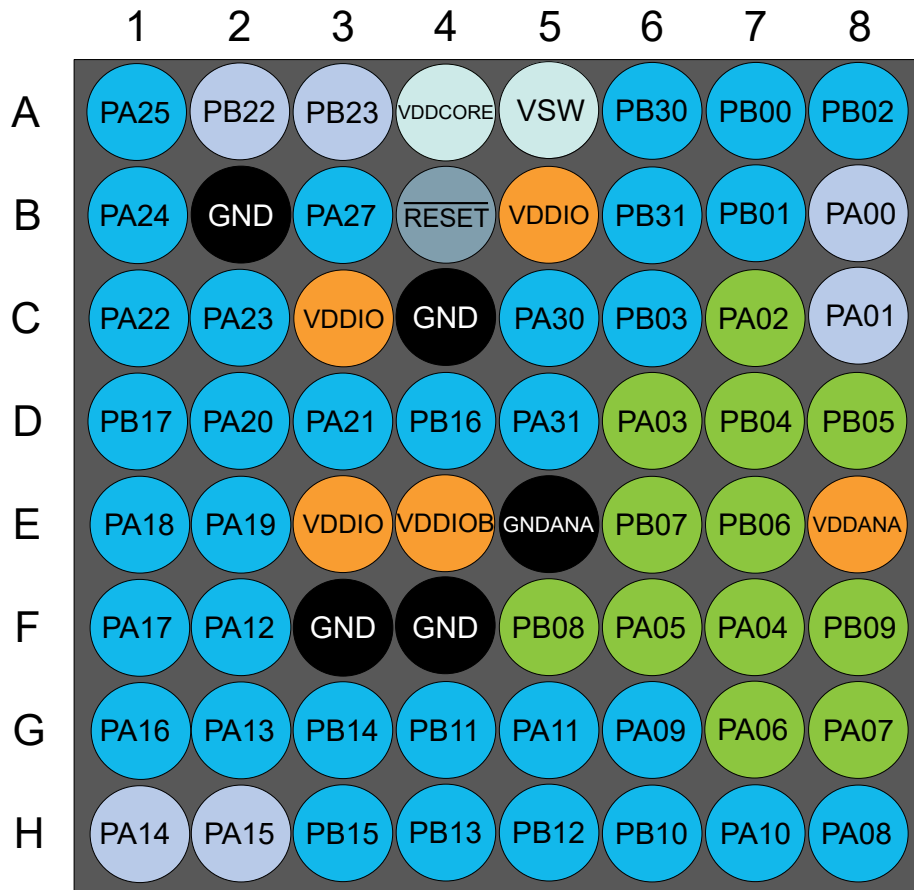
Figure 4-2. 64-Pin TQFP and VQFN <sup>(1)</sup> Package



**Note:**

1. It is recommended that the exposed pad be connected to ground in the PCB. Refer to section 58.3 Package Drawings for further information.

### 4.3 64-Pin WLCSP Package



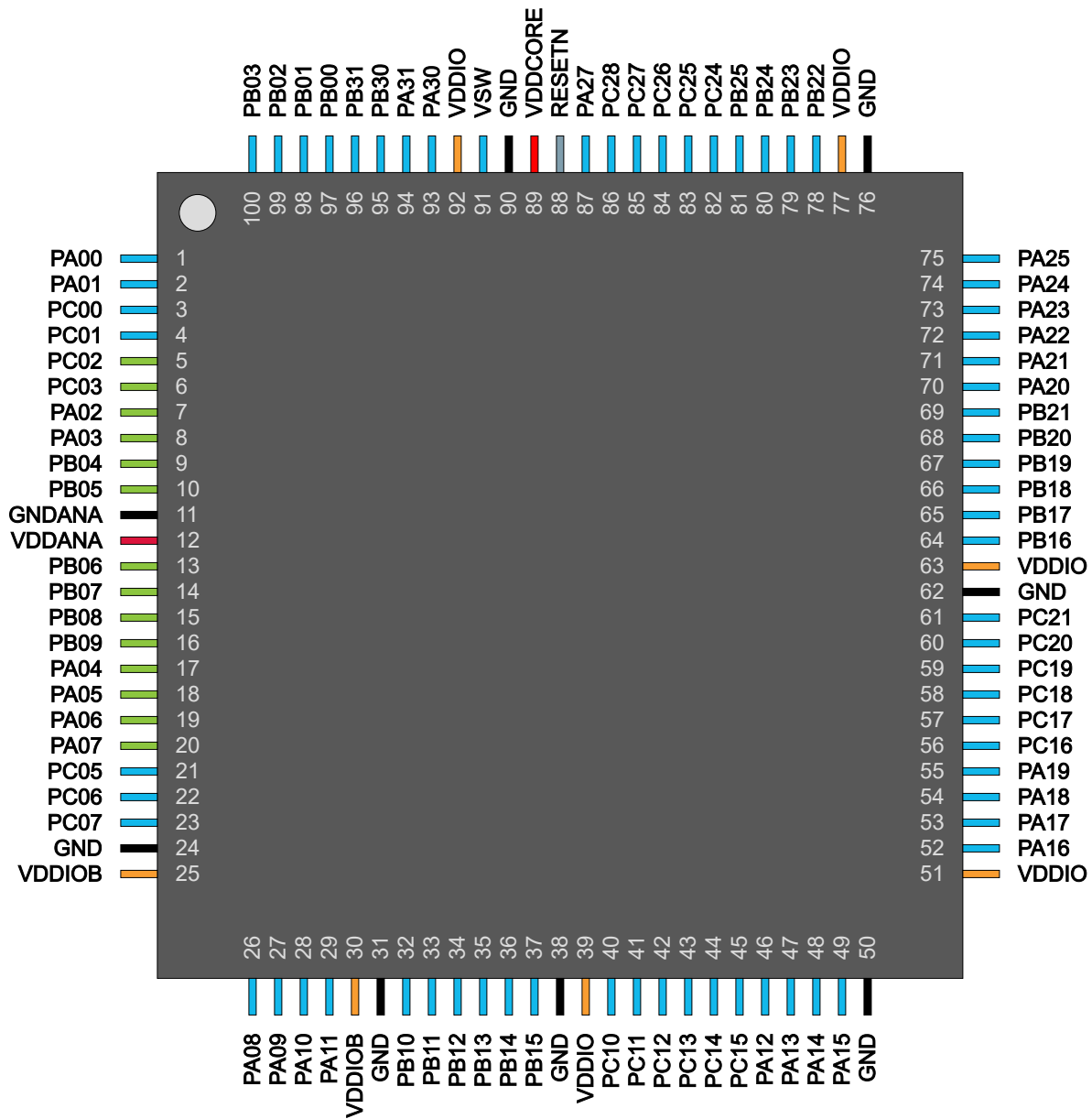
Top View

- DIGITAL PIN
- ANALOG PIN
- OSCILLATOR / DIGITAL PIN
- GROUND
- INPUT SUPPLY
- REGULATED INPUT/OUTPUT SUPPLY
- RESET PIN



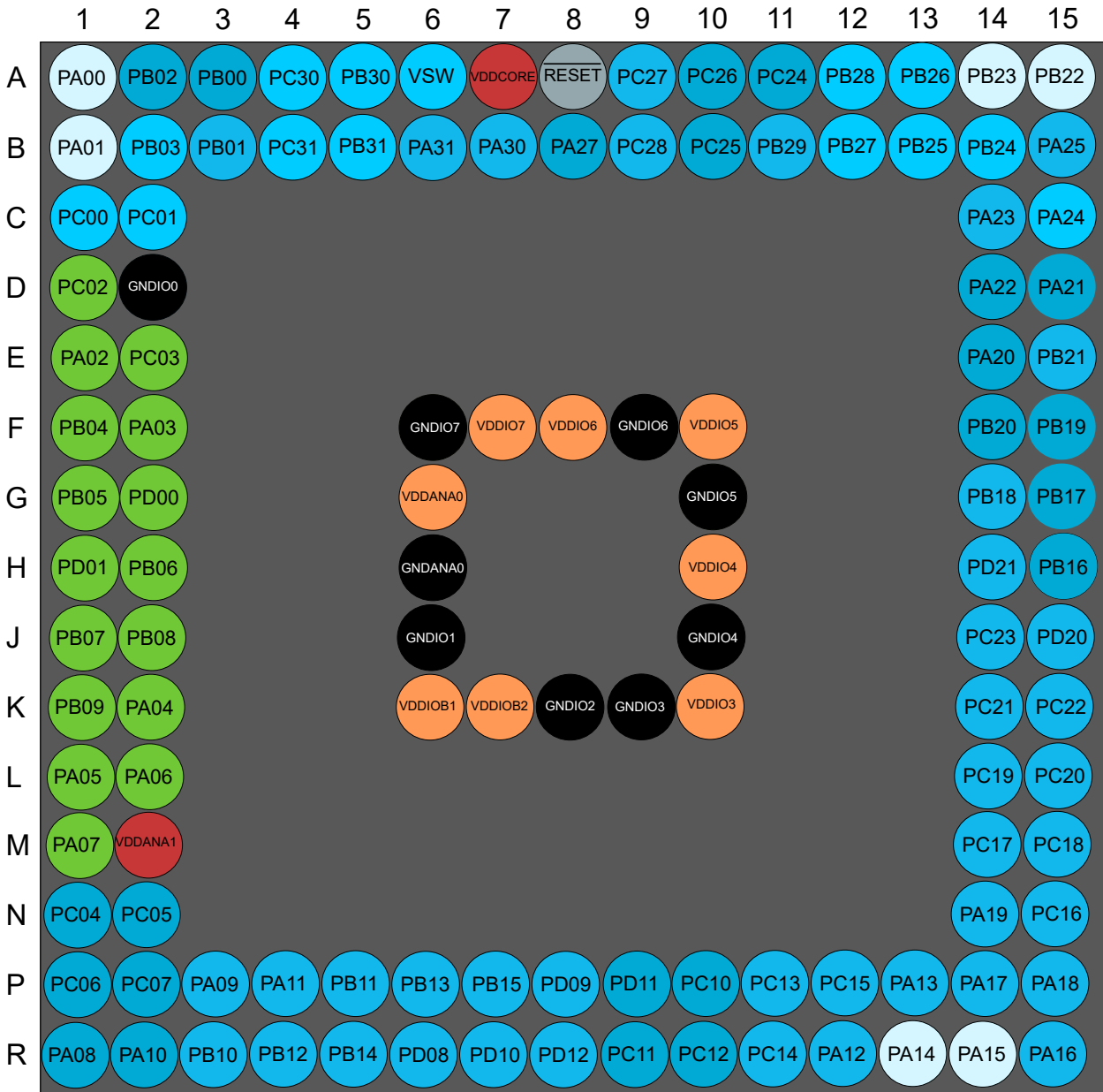
### 4.4 100-Pin TQFP Package

Figure 4-3. 100-Pin TQFP Package



### 4.5 120-ball TFBGA Package

Figure 4-4. 120-ball TFBGA Package

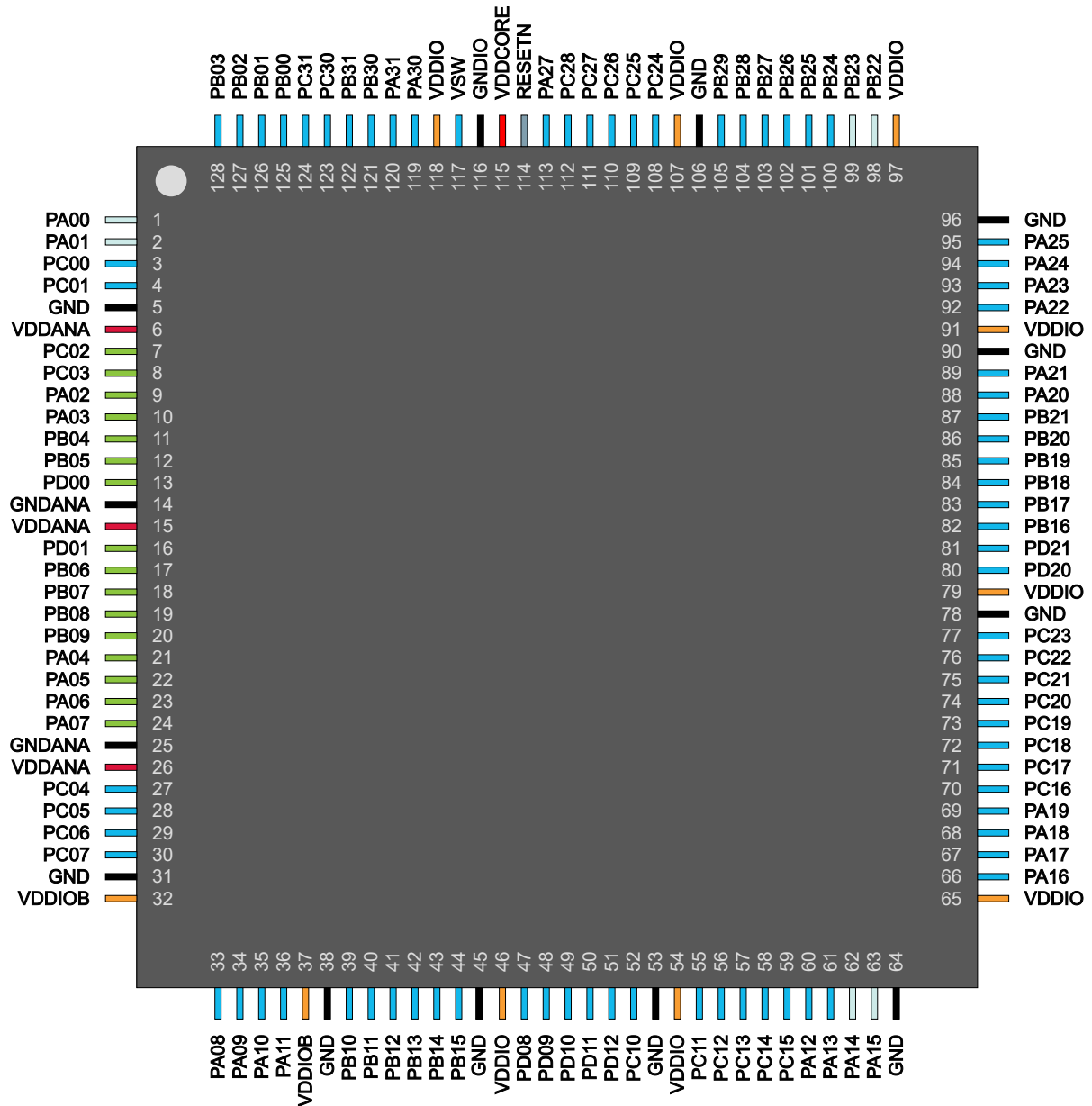


#### Top View

- DIGITAL PIN
- ANALOG PIN
- OSCILLATOR / DIGITAL PIN
- GROUND
- INPUT SUPPLY
- REGULATED INPUT/OUTPUT SUPPLY
- RESET PIN

### 4.6 128-Pin TQFP Package

Figure 4-5. 128-Pin TQFP Package



### 5. Signal Descriptions List

The following table gives details on signal names classified by peripheral.

**Table 5-1. Signal Descriptions List**

Signal Name	Function	Type	Active Level
<b>Device Service Unit - DSU</b>			
SWCLK	SW Clock	Digital	
SWDIO	SW Bidirectional Data	Digital	
RESETN	Reset input	Digital	Low
<b>Trace Port Interface Unit - TPIU</b>			
TRACEDATA[3:0]	Trace Data Output	Digital	
TRACECLK	Trace Clock	Digital	
SWO	Serial Wire Output	Digital	
<b>Analog Comparators - AC</b>			
CMP[1:0]	AC Comparator Outputs	Digital	
AIN[3:0]	AC Analog Inputs	Analog	
<b>Analog Digital Converter - ADC</b>			
AIN[15:0]	ADC Analog Inputs	Analog	
VREFA	ADC Voltage External Reference A	Analog	
VREFB	ADC Voltage External Reference B	Analog	
VREFC	ADC Voltage External Reference C	Analog	
<b>Peripheral Touch Controller - PTC</b>			
XY[31:0]	PTC X/Y Input/Output	Analog	
<b>Digital Analog Converter - DAC</b>			
VOUT[1:0]	DAC Voltage output	Analog	
VREFA	DAC Voltage External Reference	Analog	
<b>External Interrupt Controller - EIC</b>			
EXTINT[15:0]	External Interrupts inputs	Digital	
NMI	External Non-Maskable Interrupt input	Digital	
<b>Generic Clock Generator - GCLK</b>			

# SAM D5x/E5x Family Data Sheet

## Signal Descriptions List

.....continued			
Signal Name	Function	Type	Active Level
GCLK_IO[7:0]	Generic Clock (source clock inputs or generic clock generator output)	Digital	
<b>Custom Control Logic - CCL</b>			
IN[11:0]	Logic Inputs	Digital	
OUT[3:0]	Logic Outputs	Digital	
<b>Supply Controller - SUPC</b>			
VBAT	External battery supply Inputs	Analog	
OUT[1:0]	Logic Outputs	Digital	
<b>Power Manager - PM</b>			
RESETN	Reset input	Digital	Low
<b>Oscillators Control - OSCCTRL</b>			
XOSCx - XIN	Crystal or external clock Input	Analog/Digital	
XOSCx - XOUT	Crystal Output	Analog	
<b>32KHz Oscillators Control - OSC32KCTRL</b>			
XIN32	32KHz Crystal or external clock Input	Analog/Digital	
XOUT32	32KHz Crystal Output	Analog	
<b>General Purpose I/O - PORT</b>			
PA31 - PA30, PA27, PA25 - PA00	Parallel I/O Controller I/O Port A	Digital	
PB31 - PB00	Parallel I/O Controller I/O Port B	Digital	
PC31 - PC30, PC28 - PC10, PC07 - PC00	Parallel I/O Controller I/O Port C	Digital	
PD21-PD20, PD12 - PD08, PD01 - PD00	Parallel I/O Controller I/O Port D	Digital	
<b>Real-Time Counter - RTC</b>			
IN[4:0]	Tamper / Wake / Active Layer Protection Input	Digital	
OUT	Active Layer Protection Output	Digital	
<b>Timer Counter - TCx</b>			
WO[1:0]	Waveform Outputs/Capture Inputs	Digital	
<b>Timer Counter - TCCx</b>			

# SAM D5x/E5x Family Data Sheet

## Signal Descriptions List

.....continued			
Signal Name	Function	Type	Active Level
WO[7:0]	Waveform Outputs/Capture Inputs	Digital	
<b>Position Decoder - PDEC</b>			
QDI[2:0]	PDEC Inputs	Digital	
<b>Parallel Capture Controller - PCC</b>			
DEN1	Sensor Sync1	Digital	
DEN2	Sensor Sync2	Digital	
CLK	Sensor Clock	Digital	
DATA[13:0]	Sensor Data	Digital	
<b>Serial Communication Interface - SERCOMx</b>			
PAD[3:0]	SERCOM Inputs/Outputs Pads	Digital	
<b>Quad Serial Peripheral Interface - QSPI</b>			
SCK	Serial Clock	Digital	
CS	Chip Select	Digital	
DATA[3:0]	Data Input/Output	Digital	
<b>Ethernet MAC - GMAC</b>			
GTXEN	Transmit Enable	Digital	
GTXCK	Transmit Clock or Reference Clock	Digital	
GTX[3:0]	Transmit Data	Digital	
GTXER	Transmit Coding Error	Digital	
GRXER	Receive Error	Digital	
GRXCK	Receive Clock	Digital	
GRX[3:0]	Receive Data	Digital	
GRXDV	Receive Data Valid	Digital	
GCOL	Collision Detect	Digital	
GCRS	Carrier Sense and Data Valid	Digital	
GMDIO	Management Data Input/Output	Digital	
GMDC	Management Data Clock	Digital	
<b>Universal Serial Bus - USB</b>			
DP	DP for USB	Digital	
DM	DM for USB	Digital	

# SAM D5x/E5x Family Data Sheet

## Signal Descriptions List

.....continued			
Signal Name	Function	Type	Active Level
SOF 1kHz	USB Start of Frame	Digital	
<b>Control Area Network - CANx</b>			
TX	CAN Transmit	Digital	
RX	CAN Receive	Digital	
<b>Inter-IC Sound Controller - I2S</b>			
MCK1, MCK0	Master Clock	Digital	
SCK1, SCK0	Serial Clock	Digital	
FS1, FS0	I <sup>2</sup> S Word Select or TDM Frame Sync	Digital	
SDO	Serial Data Output for Transmit Serializer	Digital	
SDI	Serial Data Input for Receive Serializer	Digital	
<b>SD/MMC Host Controller - SDHCx</b>			
CD	SD Card / SDIO / e.MMC Card Detect	Digital	
CMD	SD Card / SDIO / e.MMC Command/Response Line	Digital	
WP	SD Card Connector Write Protect Signal	Digital	
CK	SD Card / SDIO / e.MMC Clock Signal	Digital	
DAT[3:0]	SD Card / SDIO / e.MMC Data Lines	Digital	

# SAM D5x/E5x Family Data Sheet

## I/O Multiplexing and Considerations

## 6. I/O Multiplexing and Considerations

### 6.1 Multiplexed Signals

By default each pin is controlled by the PORT as a general purpose I/O, and alternatively it can be assigned a different peripheral functions. To enable a peripheral function on a pin, the Peripheral Multiplexer Enable bit in the Pin Configuration register corresponding to that pin (PINCFGn.PMUXEN, n = 0-31) in the PORT must be written to '1'. The selection of peripheral functions, A to N, is done by writing to the Peripheral Multiplexing Odd and Even bits in the Peripheral Multiplexing register (PMUXn.PMUXE/O) of the PORT. The table below describes the peripheral signals multiplexed to the PORT I/O pins.



**Important:** Not all signals are available on all devices. Refer to the Configuration Summary for available peripherals.

**Table 6-1. Multiplexed Peripheral Signals**

VQFN 48	TQFP/VQFN/WLSP 64	TQFP 100	TFBGA 120	TQFP 128	Pad Name	A		B		C		D		E		F		G		H		I		J		K		L		M		N	
						EIC	ANARE F	ADC0	ADC1	AC	DAC	PTC	SERCO M	SERCO M	TC	TCC	TCC, PDEC	QSPI, CAN1, USB, CORTEX_CM4	SDHC, CAN0	I <sup>2</sup> S	PCC	GMAC	GCLK, AC	CCL									
48	64/C6	100	B2	128	PB03	EIC/EXTINT[3]	-	ADC0/AIN[15]	-	-	-	-	X21/Y2 1	-	SERCO M5/PAD[1]	TC6/WO[1]	-	-	-	-	-	-	-	-	-	-	-	-	-	-	-	-	
1	01/B8	1	A1	1	PA00	EIC/EXTINT[0]	-	-	-	-	-	-	-	SERCO M1/PAD[0]	TC2/WO[0]	-	-	-	-	-	-	-	-	-	-	-	-	-	-	-	-		
2	02/C8	2	B1	2	PA01	EIC/EXTINT[1]	-	-	-	-	-	-	-	SERCO M1/PAD[1]	TC2/WO[1]	-	-	-	-	-	-	-	-	-	-	-	-	-	-	-	-		
		3	C1	3	PC00	EIC/EXTINT[0]	-	-	ADC1/AIN[10]	-	-	-	-	-	-	-	-	-	-	-	-	-	-	-	-	-	-	-	-	-	-		
		4	C2	4	PC01	EIC/EXTINT[1]	-	-	ADC1/AIN[11]	-	-	-	-	-	-	-	-	-	-	-	-	-	-	-	-	-	-	-	-	-	-		
		5	D1	7	PC02	EIC/EXTINT[2]	-	-	ADC1/AIN[4]	-	-	-	-	-	-	-	-	-	-	-	-	-	-	-	-	-	-	-	-	-	-		
		6	E2	8	PC03	EIC/EXTINT[3]	-	-	ADC1/AIN[5]	-	-	-	-	-	-	-	-	-	-	-	-	-	-	-	-	-	-	-	-	-	-		
3	03/C7	7	E1	9	PA02	EIC/EXTINT[2]	-	ADC0/AIN[0]	-	-	-	-	-	-	-	-	-	-	-	-	-	-	-	-	-	-	-	-	-	-	-		
4	04/D6	8	F2	10	PA03	EIC/EXTINT[3]	ANARE F/VREFA	ADC0/AIN[1]	-	-	-	-	X0/Y0	-	-	-	-	-	-	-	-	-	-	-	-	-	-	-	-	-	-		
	05/D7	9	F1	11	PB04	EIC/EXTINT[4]	-	-	ADC1/AIN[6]	-	-	-	X22/Y2 2	-	-	-	-	-	-	-	-	-	-	-	-	-	-	-	-	-	-		
	06/D8	10	G1	12	PB05	EIC/EXTINT[5]	-	-	ADC1/AIN[7]	-	-	-	X23/Y2 3	-	-	-	-	-	-	-	-	-	-	-	-	-	-	-	-	-	-		
			G2	13	PD00	EIC/EXTINT[0]	-	-	ADC1/AIN[14]	-	-	-	-	-	-	-	-	-	-	-	-	-	-	-	-	-	-	-	-	-	-		
			H1	16	PD01	EIC/EXTINT[1]	-	-	ADC1/AIN[15]	-	-	-	-	-	-	-	-	-	-	-	-	-	-	-	-	-	-	-	-	-	-		
	09/E7	13	H2	17	PB06	EIC/EXTINT[6]	-	-	ADC1/AIN[8]	-	-	-	X24/Y2 4	-	-	-	-	-	-	-	-	-	-	-	-	-	-	-	-	-	CCL/IN[6]		
	10/E6	14	J1	18	PB07	EIC/EXTINT[7]	-	-	ADC1/AIN[9]	-	-	-	X25/Y2 5	-	-	-	-	-	-	-	-	-	-	-	-	-	-	-	-	-	CCL/IN[7]		



# SAM D5x/E5x Family Data Sheet

## I/O Multiplexing and Considerations

.....continued

VOFN 48	TQFP/VQFN/WLCSP 64	TQFP 100	TFBGA 120	TQFP 128	Pad Name	A		B				C			D	E	F	G	H	I	J	K	L	M	N
						EIC	ANARE F	ADC0	ADC1	AC	DAC	PTC	SERCO M	SERCO M	TC	TCC	TCC, PDEC	QSPI, CAN1, USB, CORTEX_CM4	SDHC, CAN0	I <sup>2</sup> S	PCC	GMAC	GCLK, AC	CCL	
7	11/F5	15	J2	19	PB08	EIC/EXTINT[8]	-	ADC0/AIN[2]	ADC1/AIN[0]	-	-	X1/Y1	-	SERCO M4/PAD[0]	TC4/WO[0]	-	-	-	-	-	-	-	-	-	CCL/IN[8]
8	12/F8	16	K1	20	PB09	EIC/EXTINT[9]	-	ADC0/AIN[3]	ADC1/AIN[1]	-	-	X2/Y2	-	SERCO M4/PAD[1]	TC4/WO[1]	-	-	-	-	-	-	-	-	-	CCL/OUT[2]
9	13/F7	17	K2	21	PA04	EIC/EXTINT[4]	ANARE F/VREFB	ADC0/AIN[4]	-	AC/AIN[0]	-	X3/Y3	-	SERCO M0/PAD[0]	TC0/WO[0]	-	-	-	-	-	-	-	-	-	CCL/IN[0]
10	14/F6	18	L1	22	PA05	EIC/EXTINT[5]	-	ADC0/AIN[5]	-	AC/AIN[1]	DAC/VOUT[1]	-	-	SERCO M0/PAD[1]	TC0/WO[1]	-	-	-	-	-	-	-	-	-	CCL/IN[1]
11	15/G7	19	L2	23	PA06	EIC/EXTINT[6]	ANARE F/VREFC	ADC0/AIN[6]	-	AC/AIN[2]	-	X4/Y4	-	SERCO M0/PAD[2]	TC1/WO[0]	-	-	-	-	SDHC0/SDCD	-	-	-	-	CCL/IN[2]
12	16/G8	20	M1	24	PA07	EIC/EXTINT[7]	-	ADC0/AIN[7]	-	AC/AIN[3]	-	X5/Y5	-	SERCO M0/PAD[3]	TC1/WO[1]	-	-	-	-	SDHC0/SDWP	-	-	-	-	CCL/OUT[0]
			N1	27	PC04	EIC/EXTINT[4]	-	-	-	-	-	-	SERCO M6/PAD[0]	-	-	TCC0/WO[0]	-	-	-	-	-	-	-	-	-
		21	N2	28	PC05	EIC/EXTINT[5]	-	-	-	-	-	-	SERCO M6/PAD[1]	-	-	-	-	-	-	-	-	-	-	-	-
		22	P1	29	PC06	EIC/EXTINT[6]	-	-	-	-	-	-	SERCO M6/PAD[2]	-	-	-	-	-	-	SDHC0/SDCD	-	-	-	-	-
		23	P2	30	PC07	EIC/EXTINT[9]	-	-	-	-	-	-	SERCO M6/PAD[3]	-	-	-	-	-	-	SDHC0/SDWP	-	-	-	-	-
13	17/H8	26	R1	33	PA08	EIC/NMI	-	ADC0/AIN[8]	ADC1/AIN[2]	-	-	X6/Y6	SERCO M0/PAD[0]	SERCO M2/PAD[1]	TC0/WO[0]	TCC0/WO[0]	TCC1/WO[4]	QSPI/DATA[0]	SDHC0/SDCMD	I <sup>2</sup> S/MCK[0]	-	-	-	-	CCL/IN[3]
14	18/G6	27	P3	34	PA09	EIC/EXTINT[9]	-	ADC0/AIN[9]	ADC1/AIN[3]	-	-	X7/Y7	SERCO M0/PAD[1]	SERCO M2/PAD[0]	TC0/WO[1]	TCC0/WO[1]	TCC1/WO[5]	QSPI/DATA[1]	SDHC0/SDDAT[0]	I <sup>2</sup> S/FS[0]	-	-	-	-	CCL/IN[4]
15	19/H7	28	R2	35	PA10	EIC/EXTINT[10]	-	ADC0/AIN[10]	-	-	-	X8/Y8	SERCO M0/PAD[2]	SERCO M2/PAD[2]	TC1/WO[0]	TCC0/WO[2]	TCC1/WO[6]	QSPI/DATA[2]	SDHC0/SDDAT[1]	I <sup>2</sup> S/SCK[0]	-	-	-	GCLK/IO[4]	CCL/IN[5]
16	20/G5	29	P4	36	PA11	EIC/EXTINT[11]	-	ADC0/AIN[11]	-	-	-	X9/Y9	SERCO M0/PAD[3]	SERCO M2/PAD[3]	TC1/WO[1]	TCC0/WO[3]	TCC1/WO[7]	QSPI/DATA[3]	SDHC0/SDDAT[2]	I <sup>2</sup> S/SDO	-	-	-	GCLK/IO[5]	CCL/OUT[1]
19	23/H6	32	R3	39	PB10	EIC/EXTINT[10]	-	-	-	-	-	-	SERCO M4/PAD[2]	TC5/WO[0]	TCC0/WO[4]	TCC1/WO[0]	QSPI/SCK	SDHC0/SDDAT[3]	I <sup>2</sup> S/SDI	-	-	-	-	GCLK/IO[4]	CCL/IN[11]
20	24/G4	33	P5	40	PB11	EIC/EXTINT[11]	-	-	-	-	-	-	SERCO M4/PAD[3]	TC5/WO[1]	TCC0/WO[5]	TCC1/WO[1]	QSPI/CSS	SDHC0/SDCK	I <sup>2</sup> S/FS[1]	-	-	-	-	GCLK/IO[5]	CCL/OUT[1]
	25/H5	34	R4	41	PB12	EIC/EXTINT[12]	-	-	-	-	X26/Y26	SERCO M4/PAD[0]	-	TC4/WO[0]	TCC3/WO[0]	TCC0/WO[0]	CAN1/TX	SDHC0/SDCD	I <sup>2</sup> S/SCK[1]	-	-	-	-	GCLK/IO[6]	-
	26/H4	35	P6	42	PB13	EIC/EXTINT[13]	-	-	-	-	X27/Y27	SERCO M4/PAD[1]	-	TC4/WO[1]	TCC3/WO[1]	TCC0/WO[1]	CAN1/RX	SDHC0/SDWP	I <sup>2</sup> S/MCK[1]	-	-	-	-	GCLK/IO[7]	-
	27/G3	36	R5	43	PB14	EIC/EXTINT[14]	-	-	-	-	X28/Y28	SERCO M4/PAD[2]	-	TC5/WO[0]	TCC4/WO[0]	TCC0/WO[2]	CAN1/TX	-	-	PCC/DATA[8]	GMAC/GMDC	GCLK/IO[0]	-	CCL/IN[9]	
	28/H3	37	P7	44	PB15	EIC/EXTINT[15]	-	-	-	-	X29/Y29	SERCO M4/PAD[3]	-	TC5/WO[1]	TCC4/WO[1]	TCC0/WO[3]	CAN1/RX	-	-	PCC/DATA[9]	GMAC/GMDIO	GCLK/IO[1]	-	CCL/IN[10]	
			R6	47	PD08	EIC/EXTINT[3]	-	-	-	-	-	-	SERCO M7/PAD[0]	SERCO M6/PAD[1]	-	TCC0/WO[1]	-	-	-	-	-	-	-	-	-
			P8	48	PD09	EIC/EXTINT[4]	-	-	-	-	-	-	SERCO M7/PAD[1]	SERCO M6/PAD[0]	-	TCC0/WO[2]	-	-	-	-	-	-	-	-	-
			R7	49	PD10	EIC/EXTINT[5]	-	-	-	-	-	-	SERCO M7/PAD[2]	SERCO M6/PAD[2]	-	TCC0/WO[3]	-	-	-	-	-	-	-	-	-
			P9	50	PD11	EIC/EXTINT[6]	-	-	-	-	-	-	SERCO M7/PAD[3]	SERCO M6/PAD[3]	-	TCC0/WO[4]	-	-	-	-	-	-	-	-	-
			R8	51	PD12	EIC/EXTINT[7]	-	-	-	-	-	-	-	-	-	TCC0/WO[5]	-	-	-	-	-	-	-	-	-
		40	P10	52	PC10	EIC/EXTINT[10]	-	-	-	-	-	-	SERCO M6/PAD[2]	SERCO M7/PAD[2]	-	TCC0/WO[0]	TCC1/WO[4]	-	-	-	-	-	-	-	-

# SAM D5x/E5x Family Data Sheet

## I/O Multiplexing and Considerations

.....continued

VOFN 48	TQFP/VQFN/WLCSP 64	TQFP 100	TFBGA 120	TQFP 128	Pad Name	A	B	C	D	E	F	G	H	I	J	K	L	M	N					
					EIC	ANARE F	ADC0	ADC1	AC	DAC	PTC	SERCO M	SERCO M	TC	TCC	TCC, PDEC	QSPI, CAN1, USB, CORTEX_CM4	SDHC, CAN0	I <sup>2</sup> S	PCC	GMAC	GCLK, AC	CCL	
		41	R9	55	PC11	EIC/EXTINT[11]	-	-	-	-	-	SERCO M6/PAD[3]	SERCO M7/PAD[3]	-	TCC0/WO[1]	TCC1/WO[5]	-	-	-	-	-	GMAC/GMDC	-	-
		42	R10	56	PC12	EIC/EXTINT[12]	-	-	-	-	-	SERCO M7/PAD[0]	SERCO M6/PAD[1]	-	TCC0/WO[2]	TCC1/WO[6]	-	-	-	PCC/DATA[10]	GMAC/GMIO	-	-	
		43	P11	57	PC13	EIC/EXTINT[13]	-	-	-	-	-	SERCO M7/PAD[1]	SERCO M6/PAD[0]	-	TCC0/WO[3]	TCC1/WO[7]	-	-	-	PCC/DATA[11]	-	-	-	
		44	R11	58	PC14	EIC/EXTINT[14]	-	-	-	-	-	SERCO M7/PAD[2]	SERCO M6/PAD[2]	-	TCC0/WO[4]	TCC1/WO[0]	-	-	-	PCC/DATA[12]	GMAC/GRX[3]	-	-	
		45	P12	59	PC15	EIC/EXTINT[15]	-	-	-	-	-	SERCO M7/PAD[3]	SERCO M6/PAD[3]	-	TCC0/WO[5]	TCC1/WO[1]	-	-	-	PCC/DATA[13]	GMAC/GRX[2]	-	-	
21	29/F2	46	R12	60	PA12	EIC/EXTINT[12]	-	-	-	-	-	SERCO M2/PAD[0]	SERCO M4/PAD[1]	TC2/WO[0]	TCC0/WO[6]	TCC1/WO[2]	-	SDHC0/SDCD	-	PCC/DEN1	GMAC/GRX[1]	AC/CMP[0]	-	
22	30/G2	47	P13	61	PA13	EIC/EXTINT[13]	-	-	-	-	-	SERCO M2/PAD[1]	SERCO M4/PAD[0]	TC2/WO[1]	TCC0/WO[7]	TCC1/WO[3]	-	SDHC0/SDWP	-	PCC/DEN2	GMAC/GRX[0]	AC/CMP[1]	-	
23	31/H1	48	R13	62	PA14	EIC/EXTINT[14]	-	-	-	-	-	SERCO M2/PAD[2]	SERCO M4/PAD[2]	TC3/WO[0]	TCC2/WO[0]	TCC1/WO[2]	-	-	-	PCC/CLK	GMAC/GTXCK	GCLK/IO[0]	-	
24	32/H2	49	R14	63	PA15	EIC/EXTINT[15]	-	-	-	-	-	SERCO M2/PAD[3]	SERCO M4/PAD[3]	TC3/WO[1]	TCC2/WO[1]	TCC1/WO[3]	-	-	-	-	GMAC/GRXER	GCLK/IO[1]	-	
25	35/G1	52	R15	66	PA16	EIC/EXTINT[0]	-	-	-	-	X10/Y10	SERCO M1/PAD[0]	SERCO M3/PAD[1]	TC2/WO[0]	TCC1/WO[0]	TCC0/WO[4]	-	-	-	PCC/DATA[0]	GMAC/GCRS/GRXDV(6)	GCLK/IO[2]	CCL/IN[0]	
26	36/F1	53	P14	67	PA17	EIC/EXTINT[1]	-	-	-	-	X11/Y11	SERCO M1/PAD[1]	SERCO M3/PAD[0]	TC2/WO[1]	TCC1/WO[1]	TCC0/WO[5]	-	-	-	PCC/DATA[1]	GMAC/GTXEN	GCLK/IO[3]	CCL/IN[1]	
27	37/E1	54	P15	68	PA18	EIC/EXTINT[2]	-	-	-	-	X12/Y12	SERCO M1/PAD[2]	SERCO M3/PAD[2]	TC3/WO[0]	TCC1/WO[2]	TCC0/WO[6]	-	-	-	PCC/DATA[2]	GMAC/GTX[0]	AC/CMP[0]	CCL/IN[2]	
28	38/E2	55	N14	69	PA19	EIC/EXTINT[3]	-	-	-	-	X13/Y13	SERCO M1/PAD[3]	SERCO M3/PAD[3]	TC3/WO[1]	TCC1/WO[3]	TCC0/WO[7]	-	-	-	PCC/DATA[3]	GMAC/GTX[1]	AC/CMP[1]	CCL/OUT[0]	
		56	N15	70	PC16	EIC/EXTINT[0]	-	-	-	-	-	SERCO M6/PAD[0]	SERCO M0/PAD[1]	-	TCC0/WO[0]	PDEC/QDI[0]	-	-	-	-	GMAC/GTX[2]	-	-	
		57	M14	71	PC17	EIC/EXTINT[1]	-	-	-	-	-	SERCO M6/PAD[1]	SERCO M0/PAD[0]	-	TCC0/WO[1]	PDEC/QDI[1]	-	-	-	-	GMAC/GTX[3]	-	-	
		58	M15	72	PC18	EIC/EXTINT[2]	-	-	-	-	-	SERCO M6/PAD[2]	SERCO M0/PAD[2]	-	TCC0/WO[2]	PDEC/QDI[2]	-	-	-	-	GMAC/GRXCK	-	-	
		59	L14	73	PC19	EIC/EXTINT[3]	-	-	-	-	-	SERCO M6/PAD[3]	SERCO M0/PAD[3]	-	TCC0/WO[3]	-	-	-	-	-	GMAC/GTXER	-	-	
		60	L15	74	PC20	EIC/EXTINT[4]	-	-	-	-	-	-	-	-	TCC0/WO[4]	-	-	SDHC1/SDCD	-	-	GMAC/GRXDV	-	CCL/IN[9]	
		61	K14	75	PC21	EIC/EXTINT[5]	-	-	-	-	-	-	-	-	TCC0/WO[5]	-	-	SDHC1/SDWP	-	-	GMAC/GCOL	-	CCL/IN[10]	
		-	K15	76	PC22	EIC/EXTINT[6]	-	-	-	-	-	SERCO M1/PAD[0]	SERCO M3/PAD[1]	-	TCC0/WO[6]	-	-	-	-	-	GMAC/GMDC	-	-	
		-	J14	77	PC23	EIC/EXTINT[7]	-	-	-	-	-	SERCO M1/PAD[1]	SERCO M3/PAD[0]	-	TCC0/WO[7]	-	-	-	-	-	GMAC/GMIO	-	-	
		-	J15	80	PD20	EIC/EXTINT[10]	-	-	-	-	-	SERCO M1/PAD[2]	SERCO M3/PAD[2]	-	TCC1/WO[0]	-	-	SDHC1/SDCD	-	-	-	-	-	
		-	H14	81	PD21	EIC/EXTINT[11]	-	-	-	-	-	SERCO M1/PAD[3]	SERCO M3/PAD[3]	-	TCC1/WO[1]	-	-	SDHC1/SDWP	-	-	-	-	-	
39/D4	64	H15	82	PB16	EIC/EXTINT[0]	-	-	-	-	-	-	SERCO M5/PAD[0]	-	TC6/WO[0]	TCC3/WO[0]	TCC0/WO[4]	-	SDHC1/SDCD	I <sup>2</sup> S/SCK[0]	-	-	GCLK/IO[2]	CCL/IN[11]	
40/D1	65	G15	83	PB17	EIC/EXTINT[1]	-	-	-	-	-	-	SERCO M5/PAD[1]	-	TC6/WO[1]	TCC3/WO[1]	TCC0/WO[5]	-	SDHC1/SDWP	I <sup>2</sup> S/MCK[0]	-	-	GCLK/IO[3]	CCL/OUT[3]	
		66	G14	84	PB18	EIC/EXTINT[2]	-	-	-	-	-	SERCO M5/PAD[2]	SERCO M7/PAD[2]	-	TCC1/WO[0]	PDEC/QDI[0]	-	SDHC1/SDDAT[0]	-	-	-	GCLK/IO[4]	-	

# SAM D5x/E5x Family Data Sheet

## I/O Multiplexing and Considerations

.....continued

VOFN 48	TQFP/VQFN/WLCSP 64	TQFP 100	TFBGA 120	TQFP 128	Pad Name	A	B	C	D	E	F	G	H	I	J	K	L	M	N				
					EIC	ANARE F	ADC0	ADC1	AC	DAC	PTC	SERCO M	SERCO M	TC	TCC	TCC, PDEC	QSPI, CAN1, USB, CORTEX_CM4	SDHC, CAN0	I <sup>2</sup> S	PCC	GMAC	GCLK, AC	CCL
		67	F15	85	PB19	EIC/EXTINT[3]	-	-	-	-	-	SERCO M5/PAD[3]	SERCO M7/PAD[3]	-	TCC1/WO[1]	PDEC/QDI[1]	-	SDHC1/SDDAT[1]	-	-	-	GCLK/IO[5]	-
		68	F14	86	PB20	EIC/EXTINT[4]	-	-	-	-	-	SERCO M3/PAD[0]	SERCO M7/PAD[1]	-	TCC1/WO[2]	PDEC/QDI[2]	-	SDHC1/SDDAT[2]	-	-	-	GCLK/IO[6]	-
		69	E15	87	PB21	EIC/EXTINT[5]	-	-	-	-	-	SERCO M3/PAD[1]	SERCO M7/PAD[0]	-	TCC1/WO[3]	-	-	SDHC1/SDDAT[3]	-	-	-	GCLK/IO[7]	-
29	41/D2	70	E14	88	PA20	EIC/EXTINT[4]	-	-	-	-	X14/Y14	SERCO M3/PAD[2]	SERCO M3/PAD[2]	TC7/WO[0]	TCC1/WO[4]	TCC0/WO[0]	-	SDHC1/SDCMD	I <sup>2</sup> S/FS[0]	PCC/DATA[4]	GMAC/GMDC	-	-
30	42/D3	71	D15	89	PA21	EIC/EXTINT[5]	-	-	-	-	X15/Y15	SERCO M5/PAD[3]	SERCO M3/PAD[3]	TC7/WO[1]	TCC1/WO[5]	TCC0/WO[1]	-	SDHC1/SDCK	I <sup>2</sup> S/SDO	PCC/DATA[5]	GMAC/GMDIO	-	-
31	43/C1	72	D14	92	PA22	EIC/EXTINT[6]	-	-	-	-	X16/Y16	SERCO M3/PAD[0]	SERCO M5/PAD[1]	TC4/WO[0]	TCC1/WO[6]	TCC0/WO[2]	-	CAN0/TX	I <sup>2</sup> S/SDI	PCC/DATA[6]	-	-	CCL/IN[6]
32	44/C2	73	C14	93	PA23	EIC/EXTINT[7]	-	-	-	-	X17/Y17	SERCO M3/PAD[1]	SERCO M5/PAD[0]	TC4/WO[1]	TCC1/WO[7]	TCC0/WO[3]	USB/SOF_1 KHZ	CAN0/RX	I <sup>2</sup> S/FS[1]	PCC/DATA[7]	-	-	CCL/IN[7]
33	45/B1	74	C15	94	PA24	EIC/EXTINT[8]	-	-	-	-	-	SERCO M3/PAD[2]	SERCO M5/PAD[2]	TC5/WO[0]	TCC2/WO[2]	PDEC/QDI[0]	USB/DMA	CAN0/TX	-	-	-	-	CCL/IN[8]
34	46/A1	75	B15	95	PA25	EIC/EXTINT[9]	-	-	-	-	-	SERCO M3/PAD[3]	SERCO M5/PAD[3]	TC5/WO[1]	-	PDEC/QDI[1]	USB/DP	CAN0/RX	-	-	-	-	CCL/OUT[2]
37	49/A2	78	A15	98	PB22	EIC/EXTINT[6]	-	-	-	-	-	SERCO M1/PAD[2]	SERCO M5/PAD[2]	TC7/WO[0]	-	PDEC/QDI[2]	USB/SOF_1 KHZ	-	-	-	-	GCLK/IO[0]	CCL/IN[0]
38	50/A3	79	A14	99	PB23	EIC/EXTINT[7]	-	-	-	-	-	SERCO M1/PAD[3]	SERCO M5/PAD[3]	TC7/WO[1]	-	PDEC/QDI[0]	-	-	-	-	-	GCLK/IO[1]	CCL/OUT[0]
		80	B14	100	PB24	EIC/EXTINT[8]	-	-	-	-	-	SERCO M0/PAD[0]	SERCO M2/PAD[1]	-	-	PDEC/QDI[1]	-	-	-	-	-	AC/CMP[0]	-
		81	B13	101	PB25	EIC/EXTINT[9]	-	-	-	-	-	SERCO M0/PAD[1]	SERCO M2/PAD[0]	-	-	PDEC/QDI[2]	-	-	-	-	-	AC/CMP[1]	-
		-	A13	102	PB26	EIC/EXTINT[12]	-	-	-	-	-	SERCO M2/PAD[0]	SERCO M4/PAD[1]	-	TCC1/WO[2]	-	-	-	-	-	-	-	-
		-	B12	103	PB27	EIC/EXTINT[13]	-	-	-	-	-	SERCO M2/PAD[1]	SERCO M4/PAD[0]	-	TCC1/WO[3]	-	-	-	-	-	-	-	-
		-	A12	104	PB28	EIC/EXTINT[14]	-	-	-	-	-	SERCO M2/PAD[2]	SERCO M4/PAD[2]	-	TCC1/WO[4]	-	-	-	-	I <sup>2</sup> S/SCK[1]	-	-	-
		-	B11	105	PB29	EIC/EXTINT[15]	-	-	-	-	-	SERCO M2/PAD[3]	SERCO M4/PAD[3]	-	TCC1/WO[5]	-	-	-	-	I <sup>2</sup> S/MCK[1]	-	-	-
		82	A11	108	PC24	EIC/EXTINT[8]	-	-	-	-	-	SERCO M0/PAD[2]	SERCO M2/PAD[2]	-	-	-	CORTEX_CM4/TRACE DATA[3]	-	-	-	-	-	-
		83	B10	109	PC25	EIC/EXTINT[9]	-	-	-	-	-	SERCO M0/PAD[3]	SERCO M2/PAD[3]	-	-	-	CORTEX_CM4/TRACE DATA[2]	-	-	-	-	-	-
		84	A10	110	PC26	EIC/EXTINT[10]	-	-	-	-	-	-	-	-	-	-	CORTEX_CM4/TRACE DATA[1]	-	-	-	-	-	-
		85	A9	111	PC27	EIC/EXTINT[11]	-	-	-	-	-	SERCO M1/PAD[0]	-	-	-	-	CORTEX_CM4/TRACE CLK	-	-	-	-	CORTEX_CM4/SWO	CCL/IN[4]
		86	B9	112	PC28	EIC/EXTINT[12]	-	-	-	-	-	SERCO M1/PAD[1]	-	-	-	-	CORTEX_CM4/TRACE DATA[0]	-	-	-	-	-	CCL/IN[5]
39	51/B3	87	B8	113	PA27	EIC/EXTINT[11]	-	-	-	-	X18/Y18	-	-	-	-	-	-	-	-	-	-	GCLK/IO[1]	-
40	52/B4	88	A8	114	RESET_N	-	-	-	-	-	-	-	-	-	-	-	-	-	-	-	-	-	-
45	57/C5	93	B7	119	PA30	EIC/EXTINT[14]	-	-	-	-	X19/Y19	SERCO M1/PAD[2]	-	TC6/WO[0]	TCC2/WO[0]	-	CORTEX_CM4/SWCLK	-	-	-	-	GCLK/IO[0]	CCL/IN[3]

# SAM D5x/E5x Family Data Sheet

## I/O Multiplexing and Considerations

.....continued

VOFN 48	TQFP/VQFN/WLSP 64	TQFP 100	TFBGA 120	TQFP 128	Pad Name	A										C		D		E		F		G		H		I		J		K		L		M		N	
						EIC	ANARE F	ADC0	ADC1	AC	DAC	PTC	SERCOM M	SERCOM M	TC	TCC	TCC, PDEC	QSPI, CAN1, USB, CORTEX_CM4	SDHC, CAN0	I <sup>2</sup> S	PCC	GMAC	GCLK, AC	CCL															
46	58/D5	94	B6	120	PA31	EIC/EXTINT[15]	-	-	-	-	-	-	-	-	-	SERCOM1/PAD[3]	TC6/WO[1]	TCC2/WO[1]	-	-	CORTEX_CM4/SWDIO-	-	-	-	-	-	-	-	-	-	-	-	-	-	-	CCL/OUT[1]			
	59/A6	95	A5	121	PB30	EIC/EXTINT[14]	-	-	-	-	-	-	-	-	-	SERCOM5/PAD[1]	TC0/WO[0]	TCC4/WO[0]	TCC0/WO[6]	-	-	CORTEX_CM4/SWO	-	-	-	-	-	-	-	-	-	-	-	-	-	-			
	60/B6	96	B5	122	PB31	EIC/EXTINT[15]	-	-	-	-	-	-	-	-	-	SERCOM5/PAD[0]	TC0/WO[1]	TCC4/WO[1]	TCC0/WO[7]	-	-	-	-	-	-	-	-	-	-	-	-	-	-	-	-	-			
			A4	123	PC30	EIC/EXTINT[14]	-	-	-	ADC1/AIN[12]	-	-	-	-	-	-	-	-	-	-	-	-	-	-	-	-	-	-	-	-	-	-	-	-	-	-			
			B4	124	PC31	EIC/EXTINT[15]	-	-	-	ADC1/AIN[13]	-	-	-	-	-	-	-	-	-	-	-	-	-	-	-	-	-	-	-	-	-	-	-	-	-	-			
	61/A7	97	A3	125	PB00	EIC/EXTINT[0]	-	-	ADC0/AIN[12]	-	-	-	-	X30/Y30	-	SERCOM5/PAD[2]	TC7/WO[0]	-	-	-	-	-	-	-	-	-	-	-	-	-	-	-	-	-	-	CCL/IN[1]			
	62/B7	98	B3	126	PB01	EIC/EXTINT[1]	-	-	ADC0/AIN[13]	-	-	-	-	X31/Y31	-	SERCOM5/PAD[3]	TC7/WO[1]	-	-	-	-	-	-	-	-	-	-	-	-	-	-	-	-	-	-	CCL/IN[2]			
47	63/A8	99	A2	127	PB02	EIC/EXTINT[2]	-	-	ADC0/AIN[14]	-	-	-	-	X20/Y20	-	SERCOM5/PAD[0]	TC6/WO[0]	TCC2/WO[2]	-	-	-	-	-	-	-	-	-	-	-	-	-	-	-	-	-	CCL/OUT[0]			

### Note:

- All analog pin functions are on the peripheral function B. The peripheral function B must be selected to disable the digital control of the pin. The AC has analog signals on the peripheral function B and digital signals on the peripheral function M.
- The pins used by the SERCOM in I<sup>2</sup>C mode are listed in section SERCOM I<sup>2</sup>C Configurations.
- The following High Sink pins have different properties than the regular pins: PA08, PA09, PA12, PA13, PA16, PA17, PA22, PA23, PD08, PD09.
- Clusters of multiple GPIO pins are sharing the same supply pin.
- When TRACE is used in single-wire debug mode, PC27 assumes the role of SWO. In other debug modes, PB30 assumes the SWO functionality.
- GRXDV is available on PA16 for the 64-pin package only.



**Important:** Not all signals are available on all devices. Refer to the Configuration Summary for available peripherals.

### Related Links

- [6.2.6 SERCOM I2C Configurations](#)
- [6.2.9 GPIO Clusters](#)

## 6.2 Other Functions

### 6.2.1 Oscillator Pinout

The oscillators are not mapped to the normal PORT functions and their multiplexing is controlled by registers in the Oscillators Controller (OSCCTRL) and in the 32K Oscillators Controller (OSC32KCTRL).

# SAM D5x/E5x Family Data Sheet

## I/O Multiplexing and Considerations

**Table 6-2. Oscillator Pinout**

Oscillator	Supply	Signal	I/O pin
XOSC0	VDDIO	XIN	PA14
		XOUT	PA15
XOSC1	VDDIO	XIN	PB22
		XOUT	PB23
XOSC32K	VSWOUT	XIN32	PA00
		XOUT32	PA01

**Note:** To guarantee the XOSC32K behavior in crystal mode, PC00 must be static.

**Table 6-3. XOSC32K Jitter Minimization**

Package Pin Count	Steady Signal Recommended
128	PB00, PB01, PB02, PB03, PC00, PC01
100	PB00, PB01, PB02, PB03, PC00, PC01
120	PB00, PB01, PB02, PB03, PC00, PC01
64	PB00,PB01,PB02,PB03, PA02,PA03
48	PB02, PB03,PA02,PA03

### 6.2.2 Serial Wire Debug Interface Pinout

Only the SWCLK pin is mapped to the normal PORT functions. A debugger cold-plugging or hot-plugging detection will automatically switch the SWDIO port to the SWDIO function.

**Table 6-4. Serial Wire Debug Interface Pinout**

Signal	Supply	I/O pin
SWCLK	VDDIO	PA30
SWDIO	VDDIO	PA31

### 6.2.3 Trace Port Interface Unit Pinout

The Embedded Trace Module (ETM) is leaning on Trace Port Interface Unit (TPIU) to export data out of the system.

**Table 6-5. Trace Port Interface Unit Pinout**

Signal	Supply	I/O pin
TRACE DATA[3]	VDDIO	PC24
TRACE DATA[2]	VDDIO	PC25
TRACE DATA[1]	VDDIO	PC26
TRACE DATA[0]	VDDIO	PC28
TRACE CLK	VDDIO	PC27

# SAM D5x/E5x Family Data Sheet

## I/O Multiplexing and Considerations

.....continued

Signal	Supply	I/O pin
SWO	VDDIO	PB30, PC27

### 6.2.4 Supply Controller Pinout

The outputs of the Supply Controller (SUPC) are not mapped to the normal PORT functions. They are controlled by registers in the SUPC.

**Table 6-6. SUPC Pinout**

Signal	I/O pin
OUT0	PB01
OUT1	PB02

**Note:** If the RTC is enabled to use the pins shared with the SUPC, the RTC will have higher priority.

### 6.2.5 RTC Pinout

The pins used for Tamper Detection by the Real Time Counter (RTC) are not mapped to the regular PORT functions. These pins and their multiplexing is controlled by register settings of the RTC. If many pins of the tamper detection feature is not used by the RTC, then the pin could be used for other I/O functions, by ensuring the corresponding TAMPCTRL.INACT function is disabled.

**Table 6-7. RTC Pinout**

RTC Signal	I/O Pin
IN0	PB00
IN1	PB02
IN2	PA02
IN3	PC00
IN4	PC01
OUT	PB01



**Important:** If Supply Controller (SUPC) and RTC are configured to drive pin PB1 or pin PB2, then the RTC has priority.

### 6.2.6 SERCOM I<sup>2</sup>C Configurations

The SAM D5x/E5x has up to eight instances of the serial communication interface (SERCOM) peripheral. All instances support USART, including RS485 and ISO7816, SPI and I<sup>2</sup>C protocols. The following table lists the I<sup>2</sup>C pins location.

# SAM D5x/E5x Family Data Sheet

## I/O Multiplexing and Considerations

**Table 6-8. SERCOM I<sup>2</sup>C Pinout**

Package Pin Count	Supply	I/O pins with I <sup>2</sup> C Support
128	VDDIOB	PA08, PA09
	VDDIO	PA12, PA13, PA16, PA17, PA22, PA23, PD08, PD09
120	VDDIOB	PA08, PA09
	VDDIO	PA12, PA13, PA16, PA17, PA22, PA23, PD08, PD09
100	VDDIOB	PA08, PA09
	VDDIO	PA12, PA13, PA16, PA17, PA22, PA23
64	VDDIOB	PA08, PA09
	VDDIO	PA12, PA13, PA16, PA17, PA22, PA23
48	VDDIO	PA08, PA09, PA12, PA13, PA16, PA17, PA22, PA23

### 6.2.7 TCC Configurations

The SAM D5x/E5x has five instances of the Timer/Counter for Control applications (TCC) peripheral, TCC[4:0]. The following table lists the features for each TCC instance.

**Table 6-9. TCC Configuration Summary**

TCC#	Channels (CC_NUM)	Waveform Output (WO_NUM)	Counter size	Fault	Dithering	Output matrix	Dead Time Insertion (DTI)	SWAP	Pattern generation
0	6	8	24-bit	Yes	Yes	Yes	Yes	Yes	Yes
1	4	8	24-bit	Yes	Yes	Yes	Yes	Yes	Yes
2	3	3	16-bit	Yes	-	Yes	-	-	-
3	2	2	16-bit	Yes	-	-	-	-	-
4	2	2	16-bit	Yes	-	-	-	-	-

**Note:** The number of CC registers (CC\_NUM) for each TCC corresponds to the number of compare/capture channels, so that a TCC can have more Waveform Outputs (WO\_NUM) than CC registers.

### 6.2.8 IOSET Configurations

The SAM D5x/E5x has multiple peripheral instances, mapped to different IO locations. Each peripheral IO location is called IOSET and for a given peripheral, signals from different IOSET cannot be mixed.

For a given peripheral with two pads PAD0 and PAD1:

- Valid: PAD0 and PAD1 in the same IOSET<sub>n</sub>.
- Invalid: PAD0 in IOSET<sub>x</sub> and PAD1 in IOSET<sub>y</sub>.

# SAM D5x/E5x Family Data Sheet

## I/O Multiplexing and Considerations

### 6.2.8.1 SERCOM IOSET Configurations

The following tables lists each IOSET Pins for each SERCOM instance.

**Table 6-10. SERCOM0 IO SET Configuration**

SERCOM Signal	IOSET 1 PINs	IOSET 2 PINs	IOSET 3 PINs	IOSET 4 PINs
PAD0	PA08	PB24	PA04	PC17
PAD1	PA09	PB25	PA05	PC16
PAD2	PA10	PC24	PA06	PC18
PAD3	PA11	PC25	PA07	PC19

**Table 6-11. SERCOM1 IO SET Configuration**

SERCOM Signal	IOSET 1 PINs	IOSET 2 PINs	IOSET 3 PINs	IOSET 4 PINs
PAD0	PA16	PC22	PC27	PA00
PAD1	PA17	PC23	PC28	PA01
PAD2	PA18	PD20	PB22	PA30
PAD3	PA19	PD21	PB23	PA31

**Table 6-12. SERCOM2 IO SET Configuration**

SERCOM Signal	IOSET 1 PINs	IOSET 2 PINs	IOSET 3 PINs	IOSET 4 PINs
PAD0	PA12	PB26	PA09	PB25
PAD1	PA13	PB27	PA08	PB24
PAD2	PA14	PB28	PA10	PC24
PAD3	PA15	PB29	PA11	PC25

**Table 6-13. SERCOM3 IO SET Configuration**

SERCOM Signal	IOSET 1 PINs	IOSET 2 PINs	IOSET 3 PINs	IOSET 4 PINs
PAD0	PA22	PB20	PA17	PC23
PAD1	PA23	PB21	PA16	PC22
PAD2	PA24	PA20	PA18	PD20
PAD3	PA25	PA21	PA19	PD21

**Table 6-14. SERCOM4 IO SET Configuration**

SERCOM Signal	IOSET 1 PINs	IOSET 2 PINs	IOSET 3 PINs	IOSET 4 PINs
PAD0	PB12	PB08	PA13	PB27
PAD1	PB13	PB09	PA12	PB26
PAD2	PB14	PB10	PA14	PB28
PAD3	PB15	PB11	PA15	PB29



# SAM D5x/E5x Family Data Sheet

## I/O Multiplexing and Considerations

**Table 6-15. SERCOM5 IO SET Configuration**

SERCOM Signal	IOSET 1 PINs	IOSET 2 PINs	IOSET 3 PINs	IOSET 4 PINs	IOSET 5 PINs	IOSET 6 PINs
PAD0	PB16	PA23	PA23	PA23	PB31	PB02
PAD1	PB17	PA22	PA22	PA22	PB30	PB03
PAD2	PB18	PA20	PA24	PB22	PB00	PB00
PAD3	PB19	PA21	PA25	PB23	PB01	PB01

**Table 6-16. SERCOM6 IO SET Configuration**

SERCOM Signal	IOSET 1 PINs	IOSET 2 PINs	IOSET 3 PINs	IOSET 4 PINs	IOSET 5 PINs
PAD0	PC16	PC04	PD09	PC13	PC13
PAD1	PC17	PC05	PD08	PC12	PC12
PAD2	PC18	PC06	PD10	PC14	PC10
PAD3	PC19	PC07	PD11	PC15	PC11

**Table 6-17. SERCOM7 IO SET Configuration**

SERCOM Signal	IOSET 1 PINs	IOSET 2 PINs	IOSET 3 PINs	IOSET 4 PINs	IOSET 5 PINs
PAD0	PC12	PD08	PC12	PB21	PB30
PAD1	PC13	PD09	PC13	PB20	PB31
PAD2	PC14	PD10	PC10	PB18	PA30
PAD3	PC15	PD11	PC11	PB19	PA31

### 6.2.8.2 GMAC IOSET Configurations

The following tables lists each IOSET pins for GMDIO and GMDC signals. All other GMAC signals can be used with all available IOSET configurations.

**Table 6-18. GMAC IO SET Configuration**

GMAC Signal	IOSET 1 PINs	IOSET 2 PINs	IOSET 3 PINs	IOSET 4 PINs
GMDC	PB14	PC11	PC22	PA20
GMDIO	PB15	PC12	PC23	PA21

### 6.2.8.3 I<sup>2</sup>S Configurations

The following tables lists each IOSET Pins for I<sup>2</sup>S instance.

**Table 6-19. I<sup>2</sup>S IO SET Configuration**

I <sup>2</sup> S Signal	IOSET 1 PINs	IOSET 2 PINs
MCK0	PA08	PB17
FS0	PA09	PA20

# SAM D5x/E5x Family Data Sheet

## I/O Multiplexing and Considerations

.....continued

I <sup>2</sup> S Signal	IOSET 1 PINs	IOSET 2 PINs
SCK0	PA10	PB16
SDO	PA11	PA21
SDI	PB10	PA22
FS1	PB11	PA23
SCK1	PB12	PB28
MCK1	PB13	PB29

### 6.2.8.4 TC IOSET Configurations

The following tables lists each IOSET Pins for each TC instance.

**Table 6-20. TC0 IOSET Configuration**

TC Signal	IOSET 1 PINs	IOSET 2 PINs	IOSET 3 PINs
WO0	PA04	PA08	PB30
WO1	PA05	PA09	PB31

**Table 6-21. TC1 IOSET Configuration**

TC Signal	IOSET 1 PINs	IOSET 2 PINs
WO0	PA06	PA10
WO1	PA07	PA11

**Table 6-22. TC2 IOSET Configuration**

TC Signal	IOSET 1 PINs	IOSET 2 PINs	IOSET 3 PINs
WO0	PA00	PA12	PA16
WO1	PA01	PA13	PA17

**Table 6-23. TC3 IOSET Configuration**

TC Signal	IOSET 1 PINs	IOSET 2 PINs
WO0	PA14	PA18
WO1	PA15	PA19

**Table 6-24. TC4 IOSET Configuration**

TC Signal	IOSET 1 PINs	IOSET 2 PINs	IOSET 3 PINs
WO0	PB08	PB12	PA22
WO1	PB09	PB13	PA23

# SAM D5x/E5x Family Data Sheet

## I/O Multiplexing and Considerations

**Table 6-25. TC5 IOSET Configuration**

TC Signal	IOSET 1 PINs	IOSET 2 PINs	IOSET 3 PINs
WO0	PB10	PB14	PA24
WO1	PB11	PB15	PA25

**Table 6-26. TC6 IOSET Configuration**

TC Signal	IOSET 1 PINs	IOSET 2 PINs	IOSET 3 PINs
WO0	PB16	PA30	PB02
WO1	PB03	PB17	PA31

**Table 6-27. TC7 IOSET Configuration**

TC Signal	IOSET 1 PINs	IOSET 2 PINs	IOSET 3 PINs
WO0	PA20	PB22	PB00
WO1	PA21	PB23	PB01

### 6.2.8.5 TCC IOSET Configurations

The following tables lists each IOSET Pins for each TCC instance.

**Table 6-28. TCC0 IO SET Configuration**

TCC Signal	IOSET 1 PINs	IOSET 2 PINs	IOSET 3 PINs	IOSET 4 PINs	IOSET 5 PINs	IOSET 6 PINs
WO0	PA08	PC04	PC10	PC16	PB12	PA20
WO1	PA09	PD08	PC11	PC17	PB13	PA21
WO2	PA10	PD09	PC12	PC18	PB14	PA22
WO3	PA11	PD10	PC13	PC19	PB15	PA23
WO4	PB10	PD11	PC14	PC20	PA16	PB16
WO5	PB11	PD12	PC15	PC21	PA17	PB17
WO6	PA12	PC22	PA18	PB30	N/A <sup>(1)</sup>	N/A <sup>(1)</sup>
WO7	PA13	PC23	PA19	PB31	N/A <sup>(1)</sup>	N/A <sup>(1)</sup>

**Note:** 1. The signal is available, but the edges are not aligned wrt. the other signals as specified.

**Table 6-29. TCC1 IO SET Configuration**

TCC Signal	IOSET 1 PINs	IOSET 2 PINs	IOSET 3 PINs	IOSET 4 PINs	IOSET 5 PINs
WO0	PA16	PD20	PB18	PB10	PC14
WO1	PA17	PD21	PB19	PB11	PC15
WO2	PA18	PB20	PB26	PA12	PA14
WO3	PA19	PB21	PB27	PA13	PA15

# SAM D5x/E5x Family Data Sheet

## I/O Multiplexing and Considerations

.....continued

TCC Signal	IOSET 1 PINs	IOSET 2 PINs	IOSET 3 PINs	IOSET 4 PINs	IOSET 5 PINs
WO4	PA20	PB28	PA08	PC10	N/A <sup>(1)</sup>
WO5	PA21	PB29	PA09	PC11	N/A <sup>(1)</sup>
WO6	PA22	PA10	PC12	N/A <sup>(1)</sup>	N/A <sup>(1)</sup>
WO7	PA23	PA11	PC13	N/A <sup>(1)</sup>	N/A <sup>(1)</sup>

**Note:** 1. The signal is available, but the edges are not aligned wrt. the other signals as specified.

**Table 6-30. TCC2 IO SET Configuration**

TCC Signal	IOSET 1 PINs	IOSET 2 PINs
WO0	PA14	PA30
WO1	PA15	PA31
WO2	PA24	PB02

**Table 6-31. TCC3 IO SET Configuration**

TCC Signal	IOSET 1 PINs	IOSET 2 PINs
WO0	PB12	PB16
WO1	PB13	PB17

**Table 6-32. TCC4 IO SET Configuration**

TCC Signal	IOSET 1 PINs	IOSET 2 PINs
WO0	PB14	PB30
WO1	PB15	PB31

### 6.2.8.6 PDEC IOSET Configurations

The following tables lists each IOSET Pins for PDEC instance.

**Table 6-33. PDEC IO SET Configuration**

PDEC Signal	IOSET 1 PINs	IOSET 2 PINs	IOSET 3 PINs	IOSET 4 PINs
QDI[0]	PC16	PB18	PA24	PB23
QDI[1]	PC17	PB19	PA25	PB24
QDI[2]	PC18	PB20	PB22	PB25

# SAM D5x/E5x Family Data Sheet

## I/O Multiplexing and Considerations

### 6.2.9 GPIO Clusters

**Table 6-34. GPIO Clusters (1)**

Package	Cluster	GPIO	Supply/GND Pins Connected to the Cluster
128pins	VDDIOB	PA11, PA10, PA09, PA08	VDDIOB pins 32 and 37 GND pins 31 and 38
		PB11, PB10	
		PC07, PC06, PC05, PC04	
	VDDIO	PA31, PA30, PA27, PA25, PA24, PA23, PA22, PA21, PA20, PA19, PA18, PA17, PA16, PA15, PA14, PA13, PA12	VDDIO pins 46, 54, 65, 79, 91, 97, 107, 118 GND pins 45, 53, 64, 78, 90, 96, 106, 116
		PB31, PB30, PB29, PB28, PB27, PB26, PB25, PB24, PB23, PB22, PB21, PB20, PB19, PB18, PB17, PB16, PB15, PB14, PB13, PB12,	
		PC31, PC30, PC28, PC27, PC26, PC25, PC24, PC23, PC22, PC21, PC20, PC19, PC18, PC17, PC16, PC15, PC14, PC13, PC12, PC11, PC10	
		PD21, PD20, PD12, PD11, PD10, PD09, PD08	
	VDDANA	PA07, PA06, PA05, PA04, PA03, PA02	VDDANA pins 6, 15, 26 GNDANA pins 5, 14, 25
		PB09, PB08, PB07, PB06, PB05, PB04	
		PC03, PC02	
		PD01, PD00	
	VSWOUT	PA01, PA00	VSWOUT
		PB03, PB02, PB01, PB00	
		PC01, PC00	
	120pins	VDDIOB	PA11, PA10, PA09, PA08
PB11, PB10			
PC07, PC06, PC05, PC04			
VDDIO		PA31, PA30, PA27, PA25, PA24, PA23, PA22, PA21, PA20, PA19, PA18, PA17, PA16, PA15, PA14, PA13, PA12	VDDIO pins K10,H10,F10,F8,F7 GND pins K8,K9,J10,G10,F9,F6
		PB31, PB30, PB29, PB28, PB27, PB26, PB25, PB24, PB23, PB22, PB21, PB20, PB19, PB18, PB17, PB16, PB15, PB14, PB13, PB12,	
		PC31, PC30, PC28, PC27, PC26, PC25, PC24, PC23, PC22, PC21, PC20, PC19, PC18, PC17, PC16, PC15, PC14, PC13, PC12, PC11, PC10	
		PD21, PD20, PD12, PD11, PD10, PD09, PD08	
VDDANA		PA07, PA06, PA05, PA04, PA03, PA02	VDDANA pin M2 GNDANA pin H6
		PB09, PB08, PB07, PB06, PB05, PB04	
		PC03, PC02	
		PD01, PD00	
VSWOUT		PA01, PA00	VSWOUT
		PB03, PB02, PB01, PB00	
		PC01, PC00	

# SAM D5x/E5x Family Data Sheet

## I/O Multiplexing and Considerations

.....continued			
Package	Cluster	GPIO	Supply/GND Pins Connected to the Cluster
100pins	VDDIOB	PA11, PA10, PA09, PA08	VDDIOB pins 25 and 30 GND pins 24 and 31
		PB11, PB10	
		PC07, PC06, PC05	
	VDDIO	PA31, PA30, PA27, PA25, PA24, PA23, PA22, PA21, PA20, PA19, PA18, PA17, PA16, PA15, PA14, PA13, PA12	VDDIO pins 39, 51, 63, 77, 92 GND pins 38, 50, 62, 76, 90
		PB31, PB30, PB25, PB24, PB23, PB22, PB21, PB20, PB19, PB18, PB17, PB16, PB15, PB14, PB13, PB12, PB11, PB10	
		PC28, PC27, PC26, PC25, PC24, PC21, PC20, PC19, PC18, PC17, PC16, PC15, PC14, PC13, PC12, PC11, PC10	
	VDDANA	PA07, PA06, PA05, PA04, PA03, PA02	VDDANA pin 12 GNDANA pin 11
		PB09, PB08, PB07, PB06, PB05, PB04	
		PC03, PC02	
	VSWOUT	PA01, PA00	VSWOUT
		PB03, PB02, PB01, PB00	
		PC01, PC00	
64 Pins	VDDIOB	PA11, PA10, PA09, PA08	VDDIOB pin 21 GND pin 22
		PB11, PB10	
	VDDIO	PB12, PB13, PB14, PB15, PB16, PB17, PB30, PB31	VDDIO pins 34, 48, 56 GND pins 33, 47, 54
		PA12, PA13, PA16, PA17, PA18, PA19, PA20, PA21, PA22, PA23, PA24, PA25, PA27, PA30, PA31	
		PA14, PA15, PB22, PB23	
	VDDANA	PA2, PA3, PB4, PB5, PB6, PB7, PB8, PB9, PA4, PA5, PA6, PA7	VDDANA pin 8 GNDANA pin 7
	VSWOUT	PB0, PB1, PB2, PB3, PA0, PA1	VSWOUT
	48 pins	VDDIO	PA8, PA9, PA10, PA11
PB10, PB11, PA12, PA13, PA14, PA15			
PA16, PA17, PA18, PA19, PA20, PA21, PA22, PA23, PA24, PA25			
PB22, PB23			
PA27			
PA30, PA31			
VDDANA		PA2, PA3, PB8, PB9, PA4, PA5, PA6, PA7	VDDANA pin 6 GNDANA pin 5
VSWOUT		PB2, PB3, PA0, PA1	VSWOUT

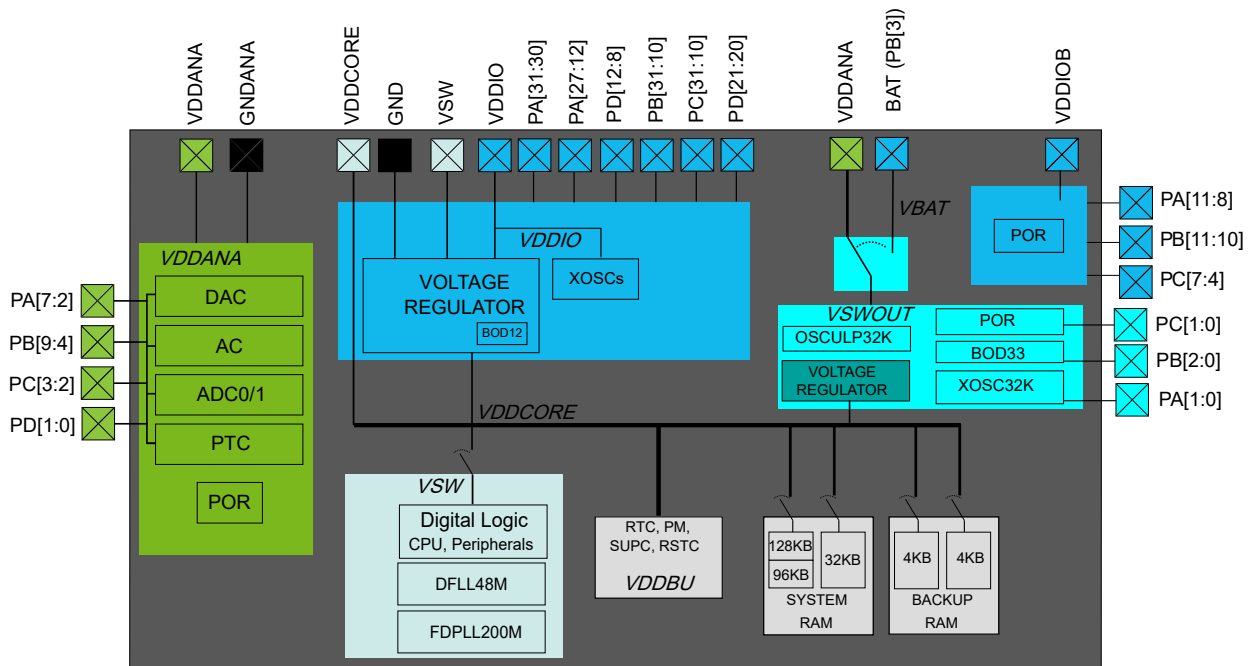
**Note:**

1. The RESETN pin in all packages are connected to the VDDIO cluster.

## 7. Power Supply and Start-Up Considerations

### 7.1 Power Domain Overview

Figure 7-1. Power Domain Block Diagram



The SAM D5x/E5x power domains are not independent of each other:

- *VDDCORE*, *VDDIO* and *VDDIOB* share *GND*, whereas *VDDANA* refers to *GNDANA*.
- *VDDANA* and *VDDIO* must share the main supply, *VDD*.
- *VDDCORE* pin is just an output for monitoring the internal voltage regulator. This is not an input for an external supply.
- *VSWOUT*, *VSW* and *VDDBU* are internal power domains.
- The *VSW* pin is for inductor connection to run the Main Voltage Regulator in switching mode.

### 7.2 Power Supply Considerations

#### 7.2.1 Power Supplies

The SAM D5x/E5x has the following power supply pins:

- *VDDIO* – Powers I/O lines, *XOSCn* and the internal regulator for *VDDCORE*. Voltage is 1.71V to 3.63V.
- *VDDIOB* – Powers I/O B lines. Voltage is 1.71V to 3.63V.
- *VDDANA* – Powers I/O lines, the Automatic Power Switch, *ADC0/1*, *AC*, *DAC* and *PTC*. Voltage is 1.71V to 3.63V.
- *VBAT* – Powers the Automatic Power Switch. Voltage is 1.71V to 3.63V

- VDDCORE – Serves as the internal voltage regulator output in linear mode, depending on the powering configuration. It powers the VSW core power domain and the VDDDBU backup domain, memories, peripherals, DFLL48M, FDPLL200M, and RAMs. Voltage is 1.2V typical.
- The Automatic Power Switch is a configurable switch that selects between VDD and VBAT as supply for the internal output VSWOUT, see the figure in [7.1 Power Domain Overview](#).

The same voltage must be applied to both VDDIO and VDDANA. This common voltage is referred to as VDD in the data sheet.

VDDIOB voltage level must be equal or lower than VDDIO.

The ground pins, GND, are common to VDDCORE, and VDDIO. The ground pin for VDDANA is GNDANA.

For decoupling recommendations for the different power supplies, refer to the schematic checklist.

### Related Links

[59. Schematic Checklist](#)

[6.2.9 GPIO Clusters](#)

[7.2.3 Typical Powering Schematic](#)

## 7.2.2 Voltage Regulator

The SAM D5x/E5x internal Main Voltage Regulator has three different modes:

- Linear mode: This is the default mode when CPU and peripherals are running. It does not require an external inductor.
- Switching mode. This is the most power efficient mode when the CPU and peripherals are running. This mode can be selected by software on the fly.
- Shutdown mode. When the chip is in backup mode, the internal regulator is off, the VSW core power domain is OFF. The VDDDBU backup domain is powered by the backup regulator (LPVREG).

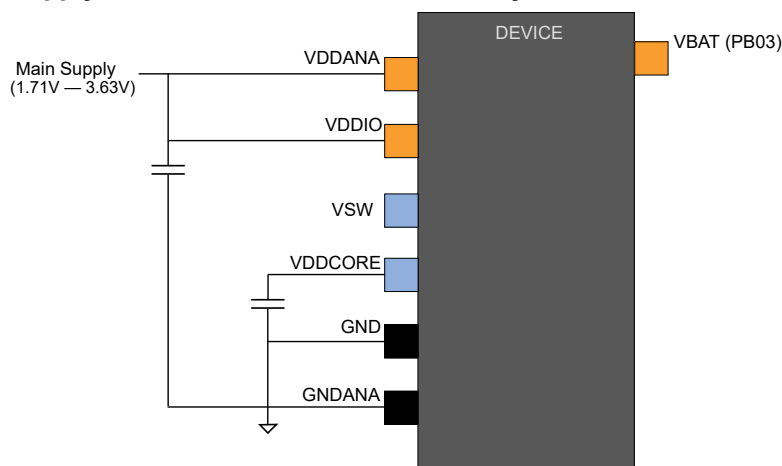
Note that the Voltage Regulator modes are controlled by the Power Manager.

## 7.2.3 Typical Powering Schematic

The SAM D5x/E5x uses a single supply from 1.71V to 3.63V.

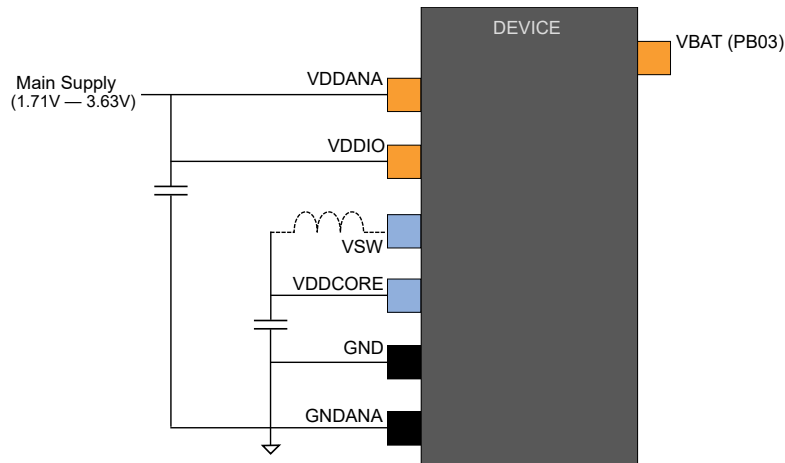
The following figure shows the recommended power supply connection.

**Figure 7-2. Power Supply Connection for Linear Mode Only**

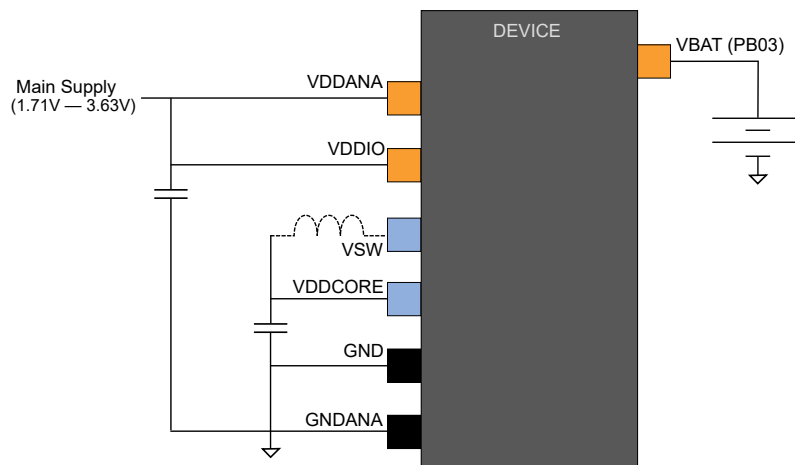




**Figure 7-3. Power Supply Connection for Switching/Linear Mode**



**Figure 7-4. Power Supply Connection for Battery Backup**



## 7.2.4 Power-Up Sequence

### 7.2.4.1 Supply Order

VDDIO and VDDANA must have the same supply sequence, and must be connected together.

Note that VDDIO supplies the XOSCn, so VDDIO must be present before the application uses the XOSC feature. This is also applicable to all digital features present on pins supplied by VDDIO. VDDIOB must be present before the application uses features present on pins supplied by VDDIOB.

### 7.2.4.2 Minimum Rise Rate

One integrated power-on reset (POR) circuits monitoring VDDANA requires a minimum rise rate.

### 7.2.4.3 Maximum Rise Rate

The rise rate of the power supplies must not exceed the values described in Electrical Characteristics.

## 7.3 Power-Up

This section summarizes the power-up sequence of the SAM D5x/E5x. The behavior after power-up is controlled by the Power Manager.

### Related Links

### 18. PM – Power Manager

#### 7.3.1 Starting of Internal Regulator

After power-up, the device is set to its initial state and kept in Reset, until the power has stabilized throughout the device.

The internal regulator provides VDDCORE. Once the external voltage VDDIO/VDDANA and VDDCORE reach a stable value, the internal Reset is released.

##### Related Links

[18. PM – Power Manager](#)

#### 7.3.2 Starting of Clocks

Once the power has stabilized and the internal Reset is released, the device will use a 48MHz clock by default. The clock source for this clock signal is DFLL48M, which is enabled after a reset by default. This is also the default time base for Generic Clock Generator 0. In turn, Generator 0 provides the main clock GCLK\_MAIN which is used by the Main Clock module (MCLK).

Some synchronous system clocks are active after Start-Up, allowing software execution. Refer to the “Clock Mask Registers” section in the MCLK-Main Clock documentation for the list of clocks that are running by default. Synchronous system clocks that are running receive the 48MHz clock from Generic Clock Generator 0. Other generic clocks are disabled.

##### Related Links

[18. PM – Power Manager](#)

#### 7.3.3 I/O Pins

After power-up, the I/O pins are tri-stated except PA30, which is pull-up enabled and configured as input in order to serve as part of the debug interface.

#### 7.3.4 Fetching of Initial Instructions

After Reset has been released, the CPU starts fetching PC and SP values from the Reset address, 0x00000000. This points to the first executable address in the internal Flash memory. The code read from the internal Flash can be used to configure the clock system and clock sources. See the related peripheral documentation for details. Refer to the ARM Architecture Reference Manual for more information on CPU startup (<http://www.arm.com>).

### 7.4 Power-On Reset and Brown-Out Detector

The SAM D5x/E5x embeds three features to monitor, warn and/or reset the device:

- POR: Power-on Reset on the main supply VDD (VDDANA/VSWOUT).
- BOD33: Brown-out detector on VSWOUT/VBAT
- Brown-out detector internal to the voltage regulator for VDDCORE. BOD12 is calibrated in production and its calibration parameters are stored in the NVM User Row. This data should not be changed if the User Row is written to in order to assure correct behavior.

#### 7.4.1 Power-On Reset on VSWOUT

VSWOUT is monitored by POR. Monitoring is always activated, including startup and all sleep modes. If VSWOUT goes below the threshold voltage, the entire chip is reset.

### 7.4.2 Power-On Reset on the main supply VDD (VDDANA/VDDIO)

The Main supply VDD (VDDANA/VDDIO) is monitored by POR. Monitoring is always activated, including startup and all sleep modes. If VDD goes below the threshold voltage, all I/Os supplied by VDDIO are reset.

### 7.4.3 Brown-Out Detector on VSWOUT/VBAT

BOD33 monitors VSWOUT or VBAT depending on configuration.

#### Related Links

[19. SUPC – Supply Controller](#)

### 7.4.4 Brown-Out Detector on VDDCORE

Once the device has started up, BOD12 monitors the internal VDDCORE.

#### Related Links

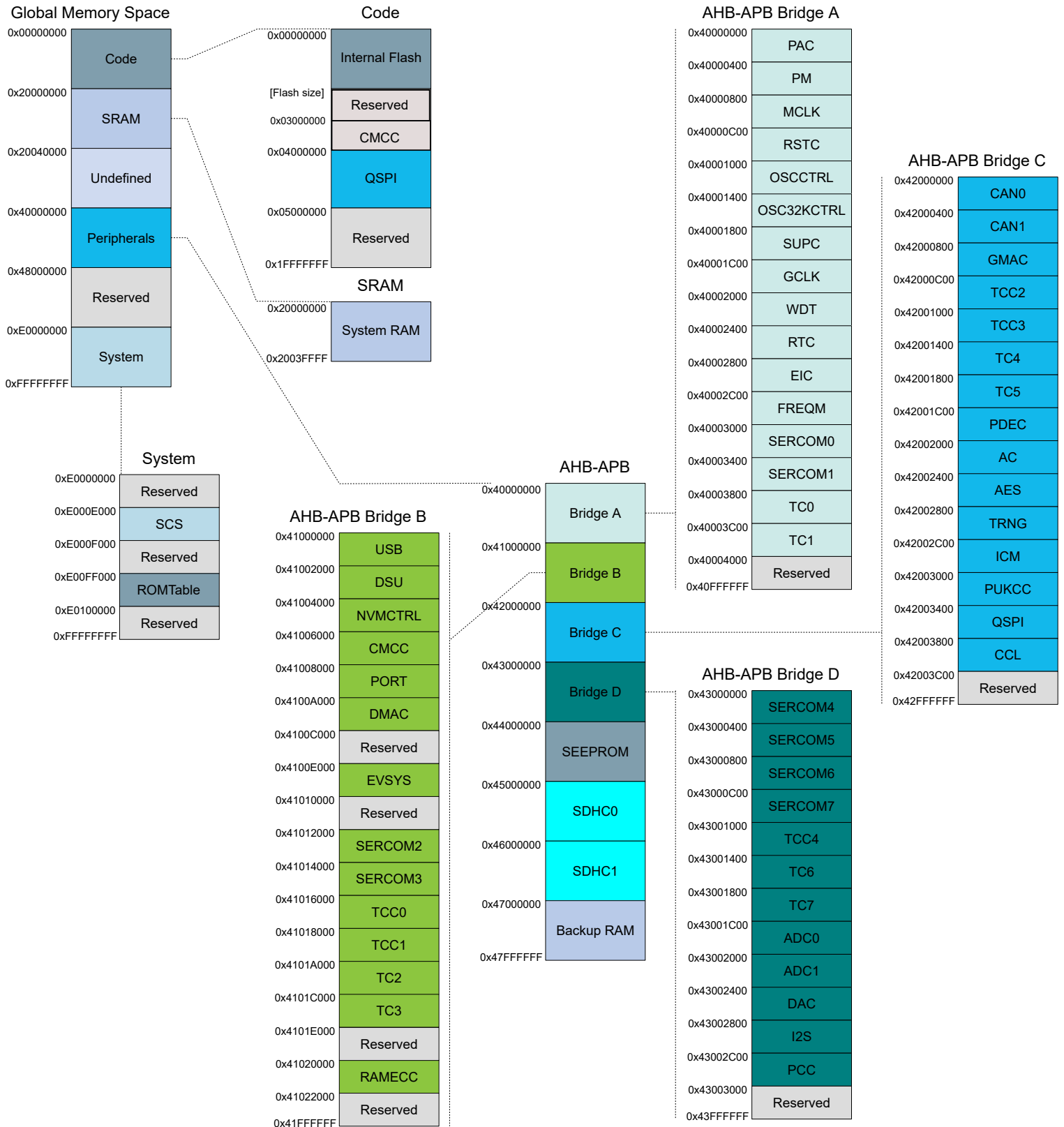
[19. SUPC – Supply Controller](#)

# SAM D5x/E5x Family Data Sheet

## Product Memory Mapping Overview

### 8. Product Memory Mapping Overview

Figure 8-1. Product Mapping



# SAM D5x/E5x Family Data Sheet

## Product Memory Mapping Overview

---

---

### Related Links

[9. Memories](#)

## 9. Memories

### 9.1 Embedded Memories

- Internal high-speed Flash with Read-While-Write (RWW) capability on a section of the array
- Internal high-speed RAM, single-cycle access at full speed
- Internal backup RAM, single-cycle access at full speed

### 9.2 Physical Memory Map

The high-speed bus is implemented as a bus matrix. All high-speed bus addresses are fixed, and they are never remapped in any way, even during boot. The 32-bit physical address space is mapped as follows:

**Table 9-1. Physical Memory Map**

Memory	Start Address	Size in KB (unless otherwise stated)		
		SAMD51x20 SAME51x20 SAME53x20 SAME54x20	SAMD51x19 SAME51x19 SAME53x19 SAME54x19	SAMD51x18 SAME51x18 SAME53x18 SAME53x18
Embedded Flash	0x00000000	1024	512	256
Embedded SRAM	0x20000000	256	192	128
Peripheral Bridge A	0x40000000	16384 Bytes		
Peripheral Bridge B	0x41000000			
Peripheral Bridge C	0x42000000			
Peripheral Bridge D	0x43000000			
Backup SRAM	0x47000000	8		
NVM User Page	0x00804000	512 Bytes		

**Note:**

1. X = G, J, N or P. Refer to [Ordering Information](#) for available device part numbers.

#### 9.2.1 Flash Memory Parameters

A single page contains 512 Bytes, which is applicable to all the device part numbers listed in the [Configuration Summary](#).

Number of pages available in a device part number will vary depending on available maximum Flash memory size.

**Equation 9-1. Calculating Flash Memory**

$$\text{Number of Pages} = \frac{\text{Flash Size (Bytes)}}{\text{Page Size (Bytes)}}$$

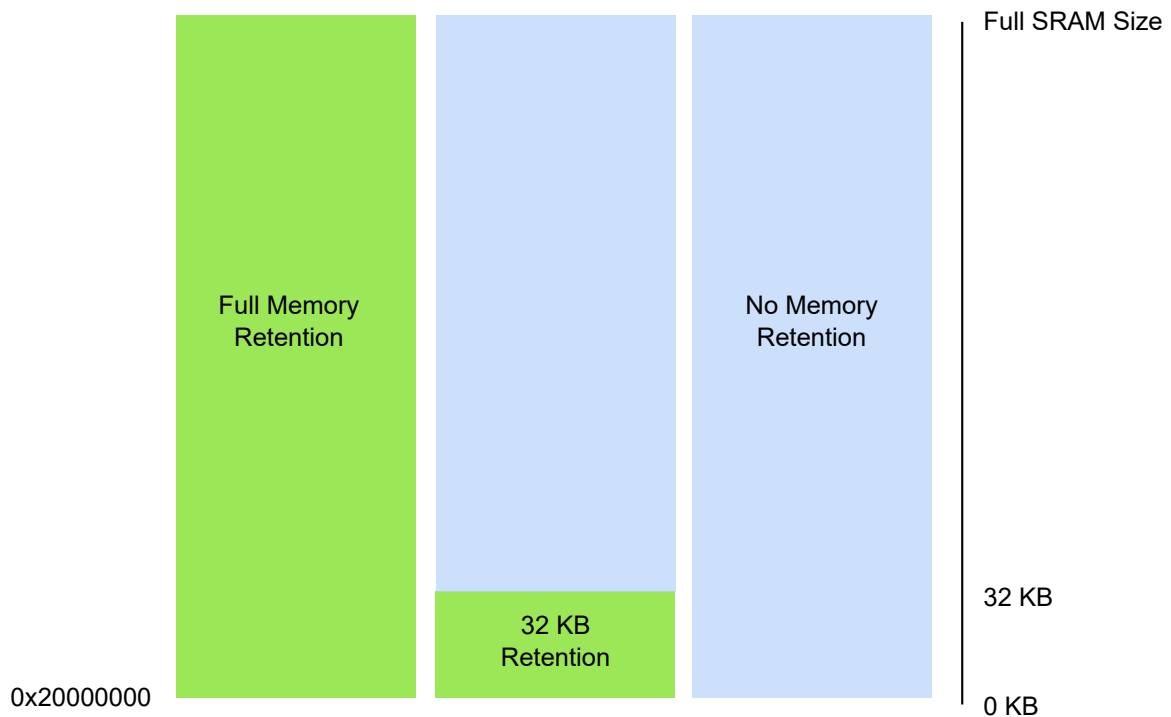
### 9.3 SRAM Memory Configuration

#### Retention

Depending on the application and power budget needs, part of the system memory can be retained in Standby or Hibernate sleep modes. The amount of the SRAM retained in this mode is software selectable, by writing the RAMCFG bits in the Power Manager Standby Configuration register and Hibernate Configuration register respectively (STDBYCFG.RAMCFG and HIBCFG.RAMCFG).

By default, the entire system memory section is retained, but no retention or bottom 32KB memory retention options are also available.

**Figure 9-1. Retention Options**

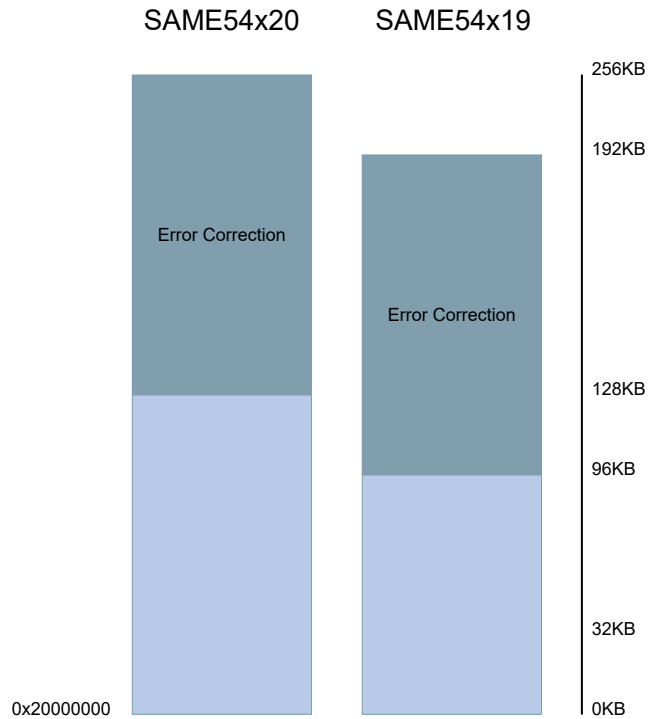


#### RAM Error Correction

For safety applications, the SAM D5x/E5x family embeds error correction codes (ECC) to detect and correct single bit errors, or to enable dual error detection for the system memory. The ECC is software selectable through the RAM ECCDIS bit in the NVM User Row. For additional information, refer to [Table 9-2](#).

When enabled, the top half system memory will be reserved to store the ECC, and will not be available for the application.

Figure 9-2. Memory with RAM Error Correction



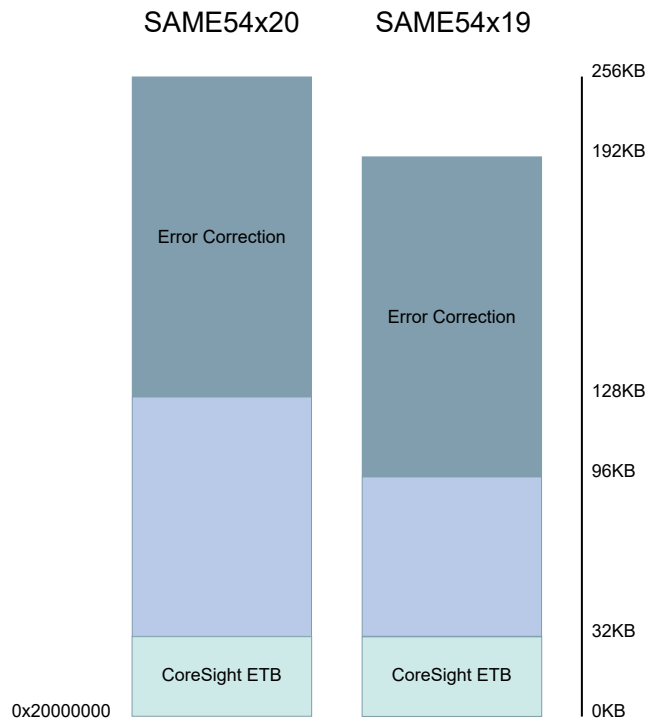
**Note:** If the ECC is used, full SRAM retention must be enabled.

### CoreSight ETB Connection

When enabled, the bottom 32 KB system memory space is reserved for CoreSight ETB debug usage. The figure below shows an example where both ECC and CoreSight ETB are enabled.



**Figure 9-3. Memory with ECC and CoreSight ETB**



## 9.4 NVM User Page Mapping

The NVM User Page can be read at address 0x00804000. The size of the NVM User Page is 512 Bytes.

The first eight 32-bit words (32 Bytes) of the Non Volatile Memory (NVM) User Page contain calibration data that are automatically read at device power on. The remaining 480 Bytes can be used for storing custom parameters.

To write the NVM User Page, refer to the NVMCTRL (Non-Volatile Memory Controller) documentation.

When writing to the user pages, the new values do not get loaded by the other peripheral on the device until a device reset occurs.

**Note:** Before erasing the NVM User Page, ensure that the first 32 Bytes are read to a buffer and later written back to the same area unless a configuration change is intended.

**Table 9-2. NVM User Page Mapping - Dedicated Entries**

Bit Pos.	Name	Usage	Related Peripheral Register	Default Values
0	BOD33 Disable	BOD33 Disable at power-on.	SUPC.BOD33	0x1
8:1	BOD33 Level	BOD33 threshold level at power-on.	SUPC.BOD33	0x1C
10:9	BOD33 Action	BOD33 Action at power-on.	SUPC.BOD33	0x1
14:11	BOD33 Hysteresis	BOD33 Hysteresis configuration at power-on.	SUPC.BOD33	0x2

# SAM D5x/E5x Family Data Sheet

## Memories

.....continued				
Bit Pos.	Name	Usage	Related Peripheral Register	Default Values
25:15	BOD12 Calibration Parameters	Factory settings - do not change. <sup>(1)</sup>		-
29:26	NVM BOOT	NVM Bootloader Size	NVMCTRL	0xF
31:30	Reserved	Factory settings - do not change.		-
35:32	SEESBLK	Number of NVM Blocks composing a SmartEEPROM sector	NVMCTRL	0x0
38:36	SEEPSZ	SmartEEPROM Page Size	NVMCTRL	0x0
39	RAM ECCDIS	RAM ECC Disable	RAMECC	0x1
47:40	Reserved	Factory settings - do not change.		-
48	WDT Enable	WDT Enable at power-on.	WDT.CTRLA	0x0
49	WDT Always-On	WDT Always-On at power-on.	WDT.CTRLA	0x0
53:50	WDT Period	WDT Period at power-on.	WDT.CONFIG	0xB
57:54	WDT Window	WDT Window mode time-out at power-on.	WDT.CONFIG	0xB
61:58	WDT EWOFFSET	WDT Early Warning Interrupt Time Offset at power-on.	WDT.EWCTRL	0xB
62	WDT WEN	WDT Timer Window Mode Enable at power-on.	WDT.CTRLA	0x0
63	Reserved	Factory settings - do not change.		-
95:64	NVM LOCKS	NVM Region Lock Bits.	NVMCTRL	0xFFFF FFFF
127:96	(fourth word)	User page		-
159:128	Reserved	Factory settings - do not change.		-
Other	-	User pages		-

**CAUTION**

1. BOD12 is calibrated in production, and the calibration parameters must not be changed to ensure the correct device behavior.

### Related Links

- [25. NVMCTRL – Nonvolatile Memory Controller](#)
- [19. SUPC – Supply Controller](#)
- [19.8.5 BOD33](#)
- [20. WDT – Watchdog Timer](#)
- [20.8.1 CTRLA](#)

[20.8.2 CONFIG](#)

[20.8.3 EWCTRL](#)

[45.6.3.1 Device Temperature Measurement](#)

### 9.5 NVM Software Calibration Area Mapping

The NVM Software Calibration Area contains calibration data that are determined and written during production test. These calibration values should be read by the application software and written back to the corresponding register.

The NVM Software Calibration Area can be read at address 0x00800080.

The NVM Software Calibration Area can not be written.

**Table 9-3. NVM Software Calibration Area Mapping**

Bit Position	Name	Description	Default Value
1:0	AC BIAS	AC Comparator 0/1 Bias Scaling. To be written to the AC CALIB register.	0x1
4:2	ADC0 BIASCOMP	Bias comparator scaling. To be written to the ADC0 CALIB register.	0x7
7:5	ADC0 BIASREFBUF	Bias reference buffer scaling. To be written to the ADC0 CALIB register.	0x7
10:8	ADC0 BIASR2R	Bias rail-to-rail amplifier scaling. To be written to the ADC0 CALIB register.	0x7
15:11	Reserved	-	-
18:16	ADC1 BIASCOMP	Bias comparator scaling. To be written to the ADC1 CALIB register.	0x7
21:19	ADC1 BIASREFBUF	Bias reference buffer scaling. To be written to the ADC1 CALIB register.	0x7
24:22	ADC1 BIASR2R	Bias rail-to-rail amplifier scaling. To be written to the ADC1 CALIB register.	0x7
35:25	Reserved	-	-
36:32	USB TRANSN	USB TRANSN calibration value. To be written to the USB PADCAL register.	0x09
41:37	USB TRANSP	USB TRANSP calibration value. To be written to the USB PADCAL register.	0x19
44:42	USB TRIM	USB TRIM calibration value. To be written to the USB PADCAL register.	0x6

The NVM Software Calibration Area for temperature calibration parameters can not be written.

The NVM Software Calibration Area for temperature calibration parameters can be read at address 0x00800100.

**Table 9-4. NVM Software Calibration Area Mapping - Temperature Calibration Parameters**

Bit Position	Name	Description
7:0	TLI	Integer part of calibration temperature TL
11:8	TLD	Decimal part of calibration temperature TL
19:12	THI	Integer part of calibration temperature TH
23:20	THD	Decimal part of calibration temperature TH
39:24	Reserved	Reserved for future use.
51:40	VPL	Temperature calibration parameters.
63:52	VPH	
75:63	VCL	
87:76	VCH	
127:88	Reserved	Reserved for future use.

**Note:** Engineering Sample devices have no valid temperature calibration parameters.

## 9.6 Serial Number

Each device has a unique 128-bit serial number which is a concatenation of four 32-bit words contained at the following addresses:

Word 0: 0x008061FC

Word 1: 0x00806010

Word 2: 0x00806014

Word 3: 0x00806018

The uniqueness of the serial number is guaranteed only when using all 128 bits.

## 10. Processor and Architecture

### 10.1 Cortex M4 Processor

The ARM®Cortex™ -M4 processor is a high performance 32-bit processor designed for the microcontroller market. It offers the following significant benefits to developers:

- Outstanding processing performance combined with fast interrupt handling
- Enhanced system debug with extensive breakpoint and trace capabilities
- Efficient processor core, system and memories
- Ultra low-power consumption with integrated sleep modes
- Platform security robustness, with integrated memory protection unit (MPU).

The implemented ARM Cortex-M4 is revision r0p1

For additional information, refer to <http://www.arm.com>

The Cortex-M4 processor is built on a high-performance processor core with a 3-stage pipeline Harvard architecture, making it ideal for demanding embedded applications. The processor delivers exceptional power efficiency through an efficient instruction set and extensively optimized design, providing high-end processing hardware including IEEE 754-compliant single-precision floating-point computation, a range of single-cycle and SIMD multiplication and multiply-with-accumulate capabilities, saturating arithmetic and dedicated hardware division.

To facilitate the design of cost-sensitive devices, the Cortex-M4 processor implements tightly-coupled system components that reduce processor area while significantly improving interrupt handling and system debug capabilities. The Cortex-M4 processor implements a version of the Thumb instruction set based on Thumb®-2 technology, ensuring high code density and reduced program memory requirements. The Cortex-M4 instruction set provides the exceptional performance expected of a modern 32-bit architecture, with the high code density of 8-bit and 16-bit microcontrollers.

The Cortex-M4 processor closely integrates a configurable NVIC, to deliver industry-leading interrupt performance. The NVIC includes a *Non-Maskable interrupt* (NMI), and provides up to 8 interrupt priority levels. The tight integration of the processor core and NVIC provides fast execution of *Interrupt Service Routines* (ISRs), dramatically reducing the interrupt latency. This is achieved through the hardware stacking of registers, and the ability to suspend load-multiple and store-multiple operations. Interrupt handlers do not require wrapping in assembler code, removing any code overhead from the ISRs. A tail-chain optimization also significantly reduces the overhead when switching from one ISR to another.

To optimize low-power designs, the NVIC integrates with the sleep modes, that include a deep sleep function that enables the entire device to be rapidly powered down while still retaining program state.

#### 10.1.1 System Level Interface

The Cortex-M4 processor provides multiple interfaces using AMBA technology to provide high-speed, low-latency memory accesses. It supports unaligned data accesses and implements atomic bit manipulation that enables faster peripheral controls, system spinlocks and thread-safe Boolean data handling.

The Cortex-M4 processor has a memory protection unit (MPU) that provides fine grain memory control, enabling applications to utilize multiple privilege levels, separating and protecting code, data and stack on a task-by-task basis. Such requirements are becoming critical in many embedded applications such as automotive.

### 10.1.2 Integrated Configurable Debug

The Cortex-M4 processor implements a complete hardware debug solution. This provides high system visibility of the processor and memory through a 2-pin *Serial Wire Debug* (SWD) port that is ideal for microcontrollers and other small package devices.

For system trace the processor integrates an *Instrumentation Trace Macrocell* (ITM) alongside data watchpoints and a profiling unit. The *Embedded Trace Macrocell* (ETM) delivers unrivaled instruction trace capture in an area far smaller than traditional trace units, enabling many low cost MCUs to implement full instruction trace for the first time.

To enable simple and cost-effective profiling of the system events these generate, a stream of software-generated messages, data trace, and profiling information is exported over three different ways:

- Output off chip using the TPIU, through a single pin, called *Serial Wire Viewer* (SWV). Limited to ITM system trace
- Output off chip using the TPIU, through a 4-bit pin interface. Bandwidth is limited
- Internally stored in RAM, using the CoreSight ETB. Bandwidth is then optimal but capacity is limited

The *Flash Patch and Breakpoint Unit* (FPB) provides up to 8 hardware breakpoint comparators that debuggers can use. The comparators in the FPB also provide remap functions of up to 8 words in the program code in the CODE memory region. This enables applications stored on a non-erasable, ROM-based microcontroller to be patched if a small programmable memory, for example flash, is available in the device. During initialization, the application in ROM detects, from the programmable memory, whether a patch is required. If a patch is required, the application programs the FPB to remap a number of addresses. When those addresses are accessed, the accesses are redirected to a remap table specified in the FPB configuration, which means the program in the non-modifiable ROM can be patched.

### 10.1.3 Cortex-M4 Processor Features and Configuration

- Thumb® instruction set combines high code density with 32-bit performance
- IEEE 754-compliant single-precision Floating Point Unit (FPU)
- Integrated sleep modes for low power consumption
- Fast code execution permits slower processor clock or increases Sleep mode time
- Hardware division and fast digital-signal-processing orientated multiply accumulate
- Saturating arithmetic for signal processing
- Deterministic, high-performance interrupt handling for time-critical applications
- Memory Protection Unit (MPU) for safety-critical applications
- Extensive debug and trace capabilities: Serial Wire Debug and Serial Wire Trace reduce the number of pins required for debugging, tracing, and code profiling.

Features	Cortex-M4 Options	SAM D5x/E5x Configuration
Interrupts	1 to 240	138
Number of priority bits	3 to 8	3 = eight levels of priority
Data endianness	Little-endian or big-endian	Little-endian
SysTick Timer calibration value		0x80000000
MPU	Present or Not present	Present

# SAM D5x/E5x Family Data Sheet

## Processor and Architecture

.....continued		
Features	Cortex-M4 Options	SAM D5x/E5x Configuration
Debug support level	0 = No debug. No DAP, breakpoints, watchpoints, Flash patch, or halting debug. 1 = Minimum debug. Two breakpoints, one watchpoint, no Flash patch. 2 = Full debug minus DWT data matching. 3 = Full debug plus DWT data matching.	3 = Full debug plus DWT data matching.
Trace support level	0 = No trace. No ETM, ITM or DWT triggers and counters. 1 = Standard trace. ITM and DWT triggers and counters, but no ETM. 2 = Full trace. Standard trace plus ETM. 3 = Full trace plus HTM port.	2 = Full trace. ITM, TPIU, ETM, and DWT triggers and counters are present. HTM port is not present
JTAG	Present or Not present	Not present
Bit Banding	Present or Not present	Not present
FPU	Present or Not present	Present

### 10.1.4 Cortex-M4 Core Peripherals

- Nested Vectored Interrupt Controller** The Nested Vector Interrupt Controller (NVIC) is an embedded interrupt controller that supports low latency interrupt processing.
- System Control Block** The System Control Block (SCB) is the programmers model interface to the processor. It provides system implementation information and system control, including configuration, control, and reporting of system exceptions. Refer to the Cortex-M4 Technical Reference Manual for details (<http://www.arm.com>).
- System Timer** The system timer, SysTick, is a 24-bit count-down timer. Use this as a Real-Time Operating System (RTOS) tick timer or as a simple counter. The SysTick timer runs on the processor clock and it does not decrement when the processor is halted for debugging. Refer to the Cortex-M4 Technical Reference Manual for details (<http://www.arm.com>).
- Memory Protection Unit** The Memory Protection Unit (MPU) improves system reliability by defining the memory attributes for different memory regions. It provides up to eight different regions, and an optional predefined background region. Refer to the Cortex-M4 Technical Reference Manual for details (<http://www.arm.com>).
- Floating-Point Unit** The Floating Point Unit (FPU) provides IEEE 754-compliant operations on single-precision, 32-bit, floating-point values. Refer to the Cortex-M4 Technical Reference Manual for details (<http://www.arm.com>).

### 10.1.5 Cortex-M4 Address Map

# SAM D5x/E5x Family Data Sheet

## Processor and Architecture

Address	Core Peripheral
0xE000E008-0xE000E00F	System control block
0xE000E010-0xE000E01F	System timer
0xE000E100-0xE000E4EF	Nested Vectored Interrupt Controller
0xE000ED00-0xE000ED3F	System control block
0xE000ED90-0xE000ED93	MPU Type Register
0xE000ED90-0xE000EDB8	Memory Protection Unit
0xE000EF00-0xE000EF03	Nested Vectored Interrupt Controller
0xE000EF30-0xE000EF44	Floating Point Unit

### Related Links

[8. Product Memory Mapping Overview](#)

## 10.2 Nested Vector Interrupt Controller

### 10.2.1 Overview

The Nested Vectored Interrupt Controller (NVIC) in the SAM D5x/E5x family devices supports 138 interrupts with eight different priority levels. For more details, refer to the Cortex-M4 Technical Reference Manual (<http://www.arm.com>).

### 10.2.2 Interrupt Line Mapping

Each of the interrupt lines is connected to one peripheral instance, as shown in the table below. Each peripheral can have many interrupt flags, located in the peripheral's Interrupt Flag Status and Clear (INTFLAG) register.

An interrupt flag is set when the interrupt condition occurs. Each interrupt in the peripheral can be individually enabled by writing a '1' to the corresponding bit in the peripheral's Interrupt Enable Set (INTENSET) register, and disabled by writing '1' to the corresponding bit in the peripheral's Interrupt Enable Clear (INTENCLR) register.

An interrupt request is generated from the peripheral when the interrupt flag is set and the corresponding interrupt is enabled.

Depending on their criticality, the interrupt requests for one peripheral are either ORed together on system level, generating one interrupt or directly connected to an NVIC interrupt lines. This is described in the table below.

An interrupt request will set the corresponding interrupt pending bit in the NVIC interrupt pending registers (SETPEND/CLRPEND bits in ISPR/ICPR).

For the NVIC to activate the interrupt, it must be enabled in the NVIC interrupt enable register (SETENA/CLRENA bits in ISER/ICER). The NVIC interrupt priority registers IPR0-IPR7 provide a priority field for each interrupt.

Module	Source	Line
EIC NMI - External Interrupt Control	NMI	NMI



# SAM D5x/E5x Family Data Sheet

## Processor and Architecture

.....continued		
Module	Source	Line
PM - Power Manager	SLEEPRDY	0
MCLK - Main Clock	CKRDY	1
OSCCTRL - Oscillators Control	XOSCFAIL 0	2
	XOSCRDY 0	
	XOSCFAIL 1	3
	XOSCRDY 1	
	DFLLLOCKC	4
	DFLLLOCKF	
	DFLLOOB	
	DFLLRCS	
	DFLLRDY	
	DPLLLCKF 0	5
	DPLLLCKR 0	
	DPLLLDRTO 0	
	DPLLLTO 0	
	DPLLLCKF 1	6
	DPLLLCKR 1	
	DPLLLDRTO 1	
DPLLLTO 1		
OSC32KCTRL - 32 kHz Oscillators Control	XOSC32KFAIL	7
	XOSC32KRDY	
SUPC - Supply Controller	BOD33RDY	8
	B33SRDY	
	VCORERDY	
	VREGRDY	
	BOD33DET	9
WDT - Watchdog Timer	EW	10

# SAM D5x/E5x Family Data Sheet

## Processor and Architecture

.....continued

Module	Source	Line
RTC - Real-Time Counter	CMP A 0	11
	CMP A 1	
	CMP A 2	
	CMP A 3	
	OVF A	
	PER A 0	
	PER A 1	
	PER A 2	
	PER A 3	
	PER A 4	
	PER A 5	
	PER A 6	
	PER A 7	
	TAMPER A	
EIC - External Interrupt Controller	EXTINT 0	12
	EXTINT 1	13
	EXTINT 2	14
	EXTINT 3	15
	EXTINT 4	16
	EXTINT 5	17
	EXTINT 6	18
	EXTINT 7	19
	EXTINT 8	20
	EXTINT 9	21
	EXTINT 10	22
	EXTINT 11	23
	EXTINT 12	24
	EXTINT 13	25
	EXTINT 14	26
	EXTINT 15	27
FREQM - Frequency Meter	DONE	28

# SAM D5x/E5x Family Data Sheet

## Processor and Architecture

.....continued

Module	Source	Line
NVMCTRL - Non-Volatile Memory Controller <sup>(1)</sup>	0	29
	1	
	2	
	3	
	4	
	5	
	6	
	7	
	8	30
	9	
10		
DMAC - Direct Memory Access Controller	SUSP 0	31
	TCMPL 0	
	TERR 0	
	SUSP 1	32
	TCMPL 1	
	TERR 1	
	SUSP 2	33
	TCMPL 2	
	TERR 2	
	SUSP 3	34
	TCMPL 3	
	TERR 3	
SUSP 4..31	35	
TCMPL 4..31		
TERR 4..31		

# SAM D5x/E5x Family Data Sheet

## Processor and Architecture

.....continued		
Module	Source	Line
EVSYS - Event System Interface	EVD 0	36
	OVR 0	
	EVD 1	37
	OVR 1	
	EVD 2	38
	OVR 2	
	EVD 3	39
	OVR 3	
	EVD 4..11	40
	OVR 4..11	
PAC - Peripheral Access Controller	ERR	41
RAM ECC	0	45
	1	
SERCOM0 - Serial Communication Interface 0 <sup>(1)</sup>	0	46
	1	47
	2	48
	3	49
	4	
	5	
	7	
SERCOM1 - Serial Communication Interface 1 <sup>(1)</sup>	0	50
	1	51
	2	52
	3	53
	4	
	5	
	7	

# SAM D5x/E5x Family Data Sheet

## Processor and Architecture

.....continued

Module	Source	Line
SERCOM2 - Serial Communication Interface 2 <sup>(1)</sup>	0	54
	1	55
	2	56
	3	57
	4	
	5	
	7	
SERCOM3 - Serial Communication Interface 3 <sup>(1)</sup>	0	58
	1	59
	2	60
	3	61
	4	
	5	
	7	
SERCOM4 - Serial Communication Interface 4 <sup>(1)</sup>	0	62
	1	63
	2	64
	3	65
	4	
	5	
	7	
SERCOM5 - Serial Communication Interface 5 <sup>(1)</sup>	0	66
	1	67
	2	68
	3	69
	4	
	5	
	7	

# SAM D5x/E5x Family Data Sheet

## Processor and Architecture

.....continued		
Module	Source	Line
SERCOM6 - Serial Communication Interface 6 <sup>(1)</sup>	0	70
	1	71
	2	72
	3	73
	4	
	5	
	7	
SERCOM7 - Serial Communication Interface 7 <sup>(1)</sup>	0	74
	1	75
	2	76
	3	77
	4	
	5	
	7	
CAN0 - Control Area Network 0	LINE 0	78
	LINE 1	
CAN1 - Control Area Network 1	LINE 0	79
	LINE 1	

# SAM D5x/E5x Family Data Sheet

## Processor and Architecture

.....continued

Module	Source	Line
USB - Universal Serial Bus	EORSM DNRSM	80
	EORST RST	
	LPM DCONN	
	LPMSUSP DDISC	
	MSOF	
	RAMACER	
	RXSTP TXSTP 0..7	
	STALL0 STALL 0..7	
	STALL1 0..7	
	SUSPEND	
	TRFAIL0 TRFAIL 0..7	
	TRFAIL1 PERR 0..7	
	UPRSM	
	WAKEUP	
	SOF HSOF	
TRCPT0 0..7	82	
TRCPT1 0..7	83	
GMAC - Ethernet MAC	GMAC	84
	WOL	

# SAM D5x/E5x Family Data Sheet

## Processor and Architecture

.....continued

Module	Source	Line
TCC0 - Timer Counter Control 0	CNT A	85
	DFS A	
	ERR A	
	FAULTA A	
	FAULTB A	
	FAULT0 A	
	FAULT1 A	
	OVF	
	TRG	
	UFS A	
	MC 0	86
	MC 1	87
	MC 2	88
	MC 3	89
TCC1 - Timer Counter Control 1	CNT A	92
	DFS A	
	ERR A	
	FAULTA A	
	FAULTB A	
	FAULT0 A	
	FAULT1 A	
	OVF	
	TRG	
	UFS A	
	MC 0	93
	MC 1	94
	MC 2	95
	MC 3	96



# SAM D5x/E5x Family Data Sheet

## Processor and Architecture

.....continued

Module	Source	Line
TCC2 - Timer Counter Control 2	CNT A	97
	DFS A	
	ERR A	
	FAULTA A	
	FAULTB A	
	FAULT0 A	
	FAULT1 A	
	OVF	
	TRG	
	UFS A	
	MC 0	98
	MC 1	99
	MC 2	100
TCC3 - Timer Counter Control 3	CNT A	101
	DFS A	
	ERR A	
	FAULTA A	
	FAULTB A	
	FAULT0 A	
	FAULT1 A	
	OVF	
	TRG	
	UFS A	
	MC 0	102
	MC 1	103

# SAM D5x/E5x Family Data Sheet

## Processor and Architecture

.....continued

Module	Source	Line	
TCC4 - Timer Counter Control 4	CNT A	104	
	DFS A		
	ERR A		
	FAULTA A		
	FAULTB A		
	FAULT0 A		
	FAULT1 A		
	OVF		
	TRG		
	UFS A		
	MC 0		105
	MC 1		106
TC0 - Basic Timer Counter 0	ERR A	107	
	MC 0		
	MC 1		
	OVF		
TC1 - Basic Timer Counter 1	ERR A	108	
	MC 0		
	MC 1		
	OVF		
TC2 - Basic Timer Counter 2	ERR A	109	
	MC 0		
	MC 1		
	OVF		
TC3 - Basic Timer Counter 3	ERR A	110	
	MC 0		
	MC 1		
	OVF		

# SAM D5x/E5x Family Data Sheet

## Processor and Architecture

.....continued		
Module	Source	Line
TC4 - Basic Timer Counter 4	ERR A	111
	MC 0	
	MC 1	
	OVF	
TC5 - Basic Timer Counter 5	ERR A	112
	MC 0	
	MC 1	
	OVF	
TC6 - Basic Timer Counter 6	ERR A	113
	MC 0	
	MC 1	
	OVF	
TC7 - Basic Timer Counter 7	ERR A	114
	MC 0	
	MC 1	
	OVF	
PDEC - Position Decoder	DIR A	115
	ERR A	
	OVF	
	VLC A	
	MC 0	116
	MC 1	117
ADC0 - Analog Digital Converter 0	OVERRUN	118
	WINMON	
	RESRDY	119
ADC1 - Analog Digital Converter 1	OVERRUN	120
	WINMON	
	RESRDY	121
AC - Analog Comparators	COMP 0	122
	COMP 1	
	WIN 0	

# SAM D5x/E5x Family Data Sheet

## Processor and Architecture

.....continued

Module	Source	Line
DAC - Digital-to-Analog Converter	OVERRUN A 0	123
	OVERRUN A 1	
	UNDERRUN A 0	
	UNDERRUN A 1	
	EMPTY 0	124
	EMPTY 1	125
	RESRDY 0	126
	RESRDY 1	127
I2S - Inter-IC Sound Interface	RXOR 0	128
	RXOR 1	
	RXRDY 0	
	RXRDY 1	
	TXRDY 0	
	TXRDY 1	
	TXUR 0	
	TXUR 1	
PCC - Parallel Capture Controller	PCC	129
AES - Advanced Encryption Standard	ENCCMP	130
	GFMCMP	
TRNG - True Random Generator	IS0	131
ICM - Integrity Check Monitor	ICM	132
PUKCC - Public-Key Cryptography Controller	PUKCC	133
QSPI - Quad SPI interface	QSPI	134
SDHC0 - SD/MMC Host Controller 0	SDHC0	135
	TIMER	
SDHC1 - SD/MMC Host Controller 1	SDHC1	136
	TIMER	

**Note:**

- The integer number specified in the source refers to the respective bit position in the INTFLAG register of respective peripheral.

**Note:** Lines not listed here are reserved.

### 10.3 High-Speed Bus System

#### 10.3.1 Features

High-Speed Bus Matrix has the following features:

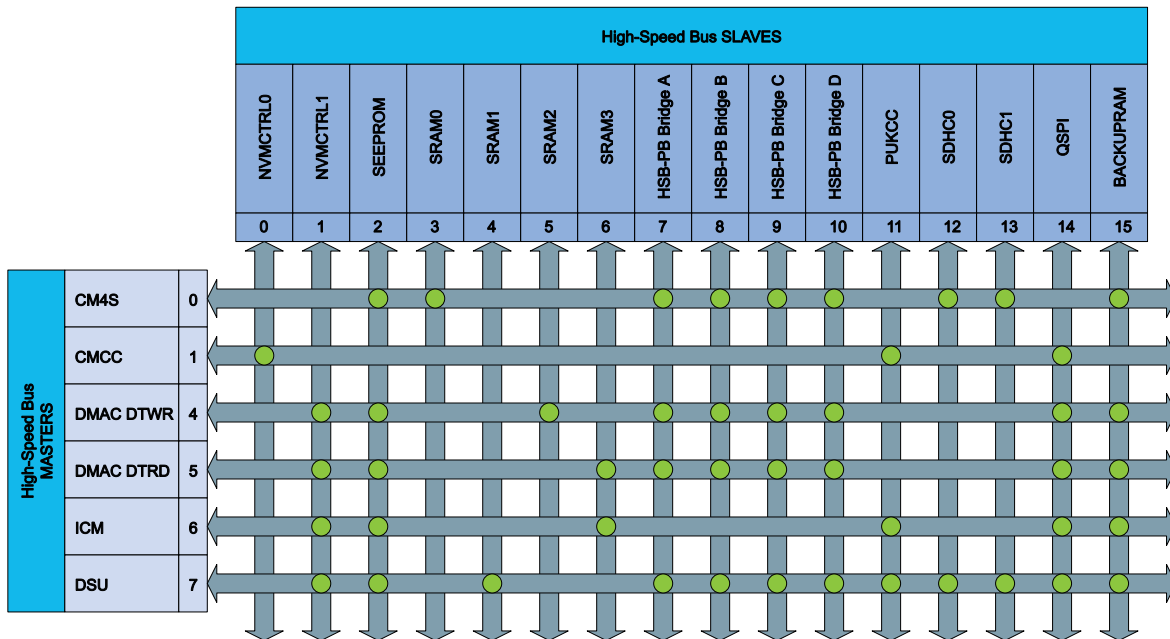
- Symmetric crossbar bus switch implementation
- Allows concurrent accesses from different masters to different slaves
- 32-bit data bus
- Operation at a one-to-one clock frequency with the bus masters

FlexRAM Memory has the following features:

- Unified System Memory area
- Allows concurrent accesses from different masters
- Offers privileged accesses from specific masters

#### 10.3.2 Configuration

**Figure 10-1. Master-Slave Relations High-Speed Bus Matrix**



**Table 10-1. High Speed Bus Matrix Masters**

High-Speed Bus Matrix Masters	Master ID
CM4S - Cortex M4 Processor	0
CMCC - Cortex-M Cache Controller	1
DMAC - Direct Memory Access Controller / Data Write Access	4
DMAC - Direct Memory Access Controller / Data Read Access	5

# SAM D5x/E5x Family Data Sheet

## Processor and Architecture

.....continued	
High-Speed Bus Matrix Masters	Master ID
ICM - Integrity Check Monitor	6
DSU - Device Service Unit	7

**Table 10-2. High-Speed Bus Matrix Slaves**

High-Speed Bus Matrix Slaves	Slave ID
Internal Flash Memory	0, 1
Smart EEPROM	2
SRAM Port 0 - CM4 Access	3
SRAM Port 1 - DSU Access	4
SRAM Port 2 - DMAC Data-Write Access	5
SRAM Port 3 - DMAC Data-Read and ICM Access	6
AHB-APB Bridge A	7
AHB-APB Bridge B	8
AHB-APB Bridge C	9
AHB-APB Bridge D	10
PUKCC	11
SDHC0	12
SDHC1	13
QSPI	14
BACKUP RAM Memory	15

### 10.3.3 SRAM Quality of Service

To ensure that masters with latency requirements get sufficient priority when accessing RAM, priority levels can be assigned to the masters for different types of access.

The Quality of Service (QoS) level is independently selected for each master accessing the RAM. For any access to the RAM, the RAM also receives the QoS level. The QoS levels and their corresponding bit values for the QoS level configuration is shown in the table below.

**Table 10-3. Quality of Service**

Value	Name	Description
0x0	DISABLE	Background (no sensitive operation)
0x1	LOW	Sensitive Bandwidth
0x2	MEDIUM	Sensitive Latency
0x3	HIGH	Critical Latency

# SAM D5x/E5x Family Data Sheet

## Processor and Architecture

If a master is configured with QoS level DISABLE (0x0) or LOW (0x1) there will be a minimum latency of one cycle for the RAM access.

The priority order for concurrent accesses are decided by two factors. First, the QoS level for the master and second, a static priority given by the port ID. The lowest port ID has the highest static priority. See the tables below for details.

The CPU QoS level can be written/read, using 32-bit access only, at address 0x4100C11C, bits [1:0]. Its reset value is 0x3.

The ICM QoS level can be written/read, using 32-bit access only, at address 0x4100C128, bits [1:0]. Its reset value is 0x1.

Refer to different master QOS control registers for configuring QoS for the other masters (DSU, DMAC, CAN, USB).

**Table 10-4. SRAM Port Connections QoS**

SRAM Port Connection	Port ID	Connection Type	QoS	default QoS
CM4 - Cortex M4 Processor	0	Bus Matrix	0x4100C11C, bits[1:0] <sup>(1)</sup>	0x3
DSU - Device Service Unit	1	Bus Matrix	IP-CFG.LQOS	0x2
DMAC - Direct Memory Access Controller - Data Access	2 (WR), 3 (RD)	Bus Matrix	IP-PRICTRL0.QOSn	0x2
ICM - Integrity Check Monitor	3	Bus Matrix	0x4100C128, bits[1:0] <sup>(1)</sup>	0x1
DMAC - Direct Memory Access Controller - Fetch Access	4, 5	Direct	IP-PRICTRL0.QOSn	0x2
DMAC - Direct Memory Access Controller - Write-Back Access	6, 7	Direct	IP-PRICTRL0.QOSn	0x2
SDHC0 - SD/MMC Host Controller	8	Direct	STATIC-1	0x1
SDHC1 - SD/MMC Host Controller	9	Direct	STATIC-1	0x1
CAN0 - Control Area Network	10	Direct	IP-MRCFG.QOS	0x1
CAN1 - Control Area Network	11	Direct	IP-MRCFG.QOS	0x1

# SAM D5x/E5x Family Data Sheet

## Processor and Architecture

.....continued

SRAM Port Connection	Port ID	Connection Type	QoS	default QoS
GMAC - Ethernet MAC	12	Direct	STATIC-2	0x2
USB - Universal Serial Bus - Configuration Access	13	Direct	IP-QOSCTRL.CQOS	0x3
USB - Universal Serial Bus - Data Access	13	Direct	IP-QOSCTRL.DQOS	0x3

**Note:** 1. Using 32-bit access only.



## 11. CMCC - Cortex M Cache Controller

### 11.1 Overview

The Cortex M Cache Controller provides an L1 cache to the Cortex M CPU. The CMCC sits transparently between the CPU and the cache leading to improved performance.

The CMCC interfaces with the CPU through the AHB, and is connected to the APB bus interface for its configuration.

### 11.2 Features

- Physically addressed and physically tagged
- L1 data and instruction cache set to 4 KB
- L1 cache line size set to 16 Bytes
- L1 cache integrates 32-bit bus master interface
- Unified 4-Way set associative cache architecture
- Lock-Down feature, which allows cached to be locked per way
- Write through cache operations, read allocate
- Configurable as data and instruction Tightly Coupled Memory (TCM)
- Round Robin victim selection policy
- Event Monitoring, with one programmable 32-bit counter
- Cache Interface includes cache maintenance operations registers

### 11.3 Block Diagram

Figure 11-1. CMCC Block Diagram

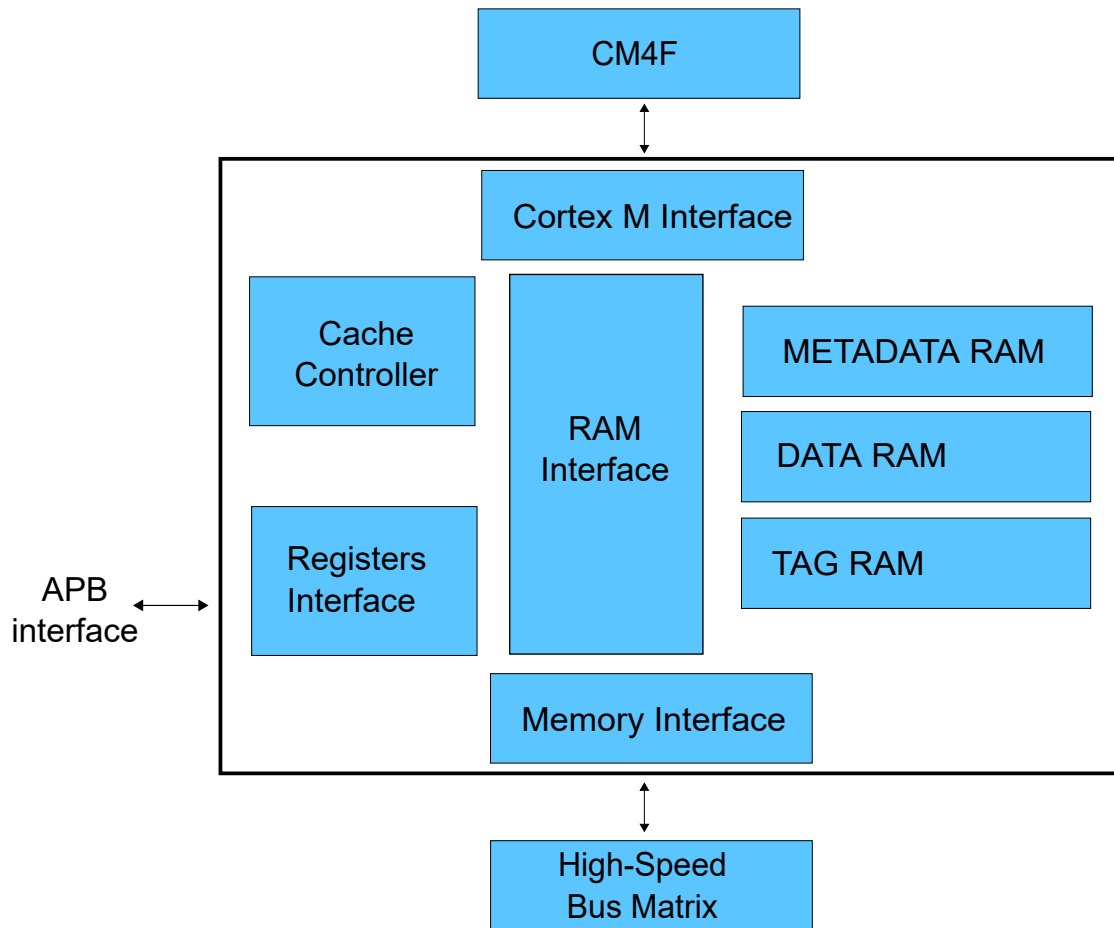
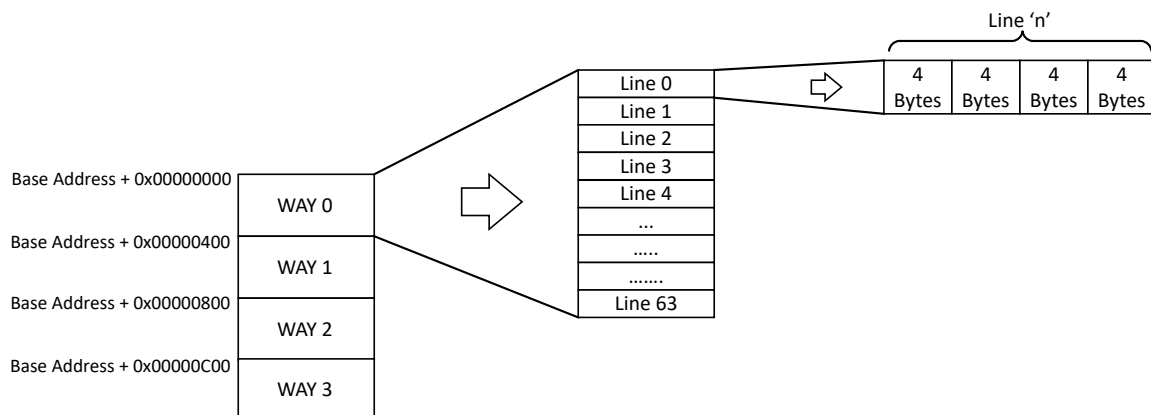


Figure 11-2. CMCC Organization



### 11.4 Signal Description

Not applicable.

### 11.5 Product Dependencies

Not applicable.

#### 11.5.1 I/O Lines

Not applicable.

#### 11.5.2 Power Management

The CMCC will continue to function as long as the CPU is not sleeping and CMCC is enabled.

#### 11.5.3 Clocks

Not applicable.

#### 11.5.4 DMA

Not applicable.

#### 11.5.5 Interrupts

Not applicable.

#### 11.5.6 Events

Not applicable.

#### 11.5.7 Debug Operation

When the CPU is halted in debug mode, the CMCC is halted. Any read access by the debugger in cached zones are not cached.

#### 11.5.8 Register Access Protection

Not applicable.

#### 11.5.9 Analog Connections

Not applicable.

### 11.6 Functional Description

#### 11.6.1 Principle of Operation

#### 11.6.2 Initialization and Normal Operation

On reset, the cache controller data entries are all invalidated, and the cache is disabled. The cache is transparent to processor operations. The cache controller is activated through the use of its configuration registers. The configuration interface is memory mapped in the APB bus.

Use the following sequence to enable the cache controller:

- Verify that the CMCC is disabled, reading the value of the SR.CSTS.
- Enable the CMCC by writing '1' in CTRL.CEN. The MODULE is disabled by writing a '0' in CTRL.CEN.

### 11.6.3 Change Cache Size

It is possible to change the cache size by writing to the Cache Size Configured By Software bits in the Cache Configuration register (CFG.CSIZESW).

Use the following sequence to change the cache size:

- Disable the CMCC controller by writing a zero to the Cache Controller Enable bit in the Cache Control register (CTRL.CEN=0).
- Check the Cache Controller Status bit in the Cache Status register to verify that the CMCC is successfully disabled (SR.CSTS=0).
- Change CFG.CSIZESW to its new value.
- Enable the CMCC by writing CTRL.CEN=1.

### 11.6.4 Data Cache Disable

The Instructions alone can be cached by disabling the Data cache, as described in the following steps:

1. Disable the cache controller by writing a '0' to CTRL.CEN.
2. Check SR.CSTS to verify whether the CMCC is successfully disabled.
3. Write CFG.DCDIS = 1.
4. Enable the CMCC by writing CTRL.CEN = 1.

### 11.6.5 Instruction Cache Disable

The Data alone can be cached by disabling the Instruction cache, as described in the following steps:

1. Disable the cache controller by writing CTRL.CEN = 0.
2. Check SR.CSTS to verify that the CMCC is successfully disabled.
3. Write CFG.ICDIS = 1.
4. Enable the CMCC by writing CTRL.CEN = 1.

### 11.6.6 Cache Load and Lock

It is possible to lock a specific way for code optimization by writing the Lock Way register (LCKWAY.LCKWAY). The locked way will not be updated by the CMCC as part of cache operations.

The load and lock mechanism can be implemented to use cache memory in a deterministic way. Follow these steps to load and lock a way:

1. Disable cache controller by clearing the CTRL.CEN bit.
2. Invalidate the desired WAY line by line. This will reset the round robin algorithm of the invalidated line, that will become eligible for the next load operation.
3. Disable the Instruction cache, but keep the Data cache enabled.
4. Enable the cache by setting the CTRL.CEN bit.
5. Place the respective piece of code and/or data to the corresponding WAY due to simple LOAD operations. Loading the piece of code and/or data will force the cache to refill the previous invalidated line in the right way. No need to load all the bytes of the line, only the first byte. The cache will automatically refill the complete line.
6. Lock the specific WAY by setting LCKWAY.LCKWAY[3:0].
7. Re-enable the instruction cache. The locked WAY is now loaded and ready to operate. The remaining WAYS can be used as I-cache or D-cache as required.

### 11.6.7 Tightly Coupled Memory

Users can use a part of the cache as Tightly Coupled Memory (TCM). The cache size is determined by the Cache Size Configuration by Software bits in the Cache Configuration register (CFG.CSIZESW). The relation between cache and TCM is as given below:

TCM size = maximum Cache size - configured Cache size.

The TCM start address can be obtained from the product memory mapping. The cache memory starts first from the address followed by the TCM memory. Size of the Way is fixed and the number of ways varies according to the available size for the cache memory. For additional information, refer to the section [Product Memory Mapping](#).

**Table 11-1. TCM Sizes**

Max. Cache	Configured Cache	TCM Size
4 KB	4 KB	0 KB
4 KB	1 KB	3 KB
4 KB	2 KB	2 KB
4 KB	0 KB	4 KB

The TCM is also accessible in its maximum size when the CMCC is disabled. The TCM does not need to be locked in order to operate.

**Note:** Writing into the cache DATA RAM region through the CPU can overwrite the valid cache lines. This can result in data corruption when the cache controller is accessing the data for cache transactions. Access the DATA RAM region only after configuring it as TCM.

### 11.6.8 Cache Maintenance

#### 11.6.8.1 Cache Invalidate by Line Operation

When an invalidate by line command is issued, the CMCC resets the valid bit information of the decoded cache line. As the line is no longer valid, the replacement counter points to that line.

- Disable the cache controller by writing a zero to the Cache Controller Enable bit in the Cache Control register (CTRL.CEN).
- Check SR.CSTS to verify that the CMCC is successfully disabled.
- Perform an invalidate by line by writing the set {index,way} in the Cache Maintenance 1 register (MAINT1.INDEX, MAINT1.WAY).
- Enable the CMCC by writing a '1' to CTRL.CEN.

#### 11.6.8.2 Cache Invalidate All Operation

Use the following sequence to invalidate all cache entries.

- Disable the cache controller by writing a zero to the Cache Enable bit in the Cache Control register (CTRL.CEN).
- Check SR.CSTS to verify that the CMCC is successfully disabled.
- Perform a full invalidate operation by writing a '1' to the Cache Controller Invalidate All bit in the Cache Maintenance 0 register (MAINT0.INVALL).
- Enable the CMCC by writing a '1' to CTRL.CEN.

### 11.6.9 Cache Performance Monitoring

The Cortex M cache controller includes a programmable monitor/32-bit counter. The monitor can be configured to count the number of clock cycles, the number of data hit or the number of instruction hit.

It is important to know that the Cortex-M4 processor prefetches instructions ahead of execution. It performs only 32-bit read access on the Instruction Bus, which means:

- One arm instruction is fetched per bus access
- Two thumb instructions are fetched per bus access

As a consequence, two thumb instructions (e.g., `NOB`) need one bus access, which results in the HIT counter incrementing by 1.

Use the following sequence to activate the counter:

- Configure the monitor counter by writing the `MCFG.MODE`.
  - `CYCLE_COUNT` is used to increment the counter along with the program counter, to count the number of cycles.
  - `IHIT_COUNT` is the instruction Hit counter, which increments the counter when there is a hit for the instruction in the cache.
  - `DHIT_COUNT` is the data Hit counter which increments the counter when there is a hit for the data in the cache.
- Enable the counter by writing a '1' to the Cache Controller Monitor Enable bit in the Cache Monitor Enable register (`MEN.MENABLE`).
- If required, reset the counter by writing a '1' to the Cache Controller Software Reset bit in the Cache Monitor Control register (`MCTRL.SWRST`).
- Check the value of the monitor counter by reading the `MSR.EVENT_CNT` bit field.

### 11.7 DEBUG Mode

In Debug mode, TAG and METADATA RAM blocks content is read/written through the AHB bus interface if the CMCC is disabled. When the CMCC is enabled, the TAG and METADATA RAM blocks are non readable.

Debug access has the same R/W properties as the CPU access for the DATA RAM block.

The TAG, METADATA and DATA RAM blocks' R/W properties are summarized in [RAM Properties](#).

Use the following sequence to perform read access with the Debugger to the three RAM blocks:

- Disable the cache controller by writing a zero to the Cache Controller Enable bit in the Cache Control register (`CTRL.CEN`).
- Check the Cache Controller Status bit in the Cache Status register (`SR.CSTS`) to verify that the CMCC is successfully disabled.
- Perform a read or write access through Debugger:
  - @ `CMCC_AHB_ADDR` for DATA RAM,
  - @ `CMCC_AHB_ADDR_TAG` for TAG RAM,
  - @ `CMCC_AHB_ADDR_MTDATA` for METADATA RAM.
- If a write access has been performed in the TAG, METADATA, or DATA RAM in the cache section, an invalid operation must be performed before re-enabling the CMCC.

#### Related Links

[11.8 RAM Properties](#)

### 11.8 RAM Properties

The following table shows the different access properties of the three RAM blocks, according the different modes described in the previous chapters.

**Table 11-2. Access to RAM**

Access Condition	DATA RAM	TAG RAM	METADATARAM
CPU access when CMCC DISABLED	R/W	no R/W - hardfault	no R/W - hardfault
CPU access when CMCC ENABLED	CACHE section configured: R/W <sup>(1)</sup> TCM section configured: R/W	no R/W - hardfault	no R/W - hardfault
Debugger access when CMCC DISABLED	R/W	R/W	R/W
Debugger access when CMCC ENABLED	CACHE section configured: R/W <sup>(1)</sup> TCM section configured: R/W	no R/W	no R/W

**Note:**

1. A write operation in this zone can corrupt the coherency of the cache. An invalidate operation may be needed.

**Related Links**

[11.7 DEBUG Mode](#)

# SAM D5x/E5x Family Data Sheet

## CMCC - Cortex M Cache Controller

### 11.9 Register Summary

Offset	Name	Bit Pos.							
0x00	TYPE	7:0	LCKDOWN	WAYNUM[1:0]	RRP	LRUP	RANDP	GCLK	AP
		15:8			CLSIZE[2:0]		CSIZE[2:0]		
		23:16							
		31:24							
0x04	CFG	7:0		CSIZESW[2:0]			DCDIS	ICDIS	
		15:8							
		23:16							
		31:24							
0x08	CTRL	7:0							CEN
		15:8							
		23:16							
		31:24							
0x0C	SR	7:0							CSTS
		15:8							
		23:16							
		31:24							
0x10	LCKWAY	7:0				LCKWAY[3:0]			
		15:8							
		23:16							
		31:24							
0x14 ... 0x1F	Reserved								
0x20	MAINT0	7:0							INVALL
		15:8							
		23:16							
		31:24							
0x24	MAINT1	7:0	INDEX[3:0]				INDEX[7:4]		
		15:8							
		23:16							
		31:24	WAY[3:0]						
0x28	MCFG	7:0					MODE[1:0]		
		15:8							
		23:16							
		31:24							
0x2C	MEN	7:0							MENABLE
		15:8							
		23:16							
		31:24							
0x30	MCTRL	7:0							SWRST
		15:8							
		23:16							
		31:24							



# SAM D5x/E5x Family Data Sheet

## CMCC - Cortex M Cache Controller

.....continued

Offset	Name	Bit Pos.								
0x34	MSR	7:0	EVENT_CNT[7:0]							
		15:8	EVENT_CNT[15:8]							
		23:16	EVENT_CNT[23:16]							
		31:24	EVENT_CNT[31:24]							

### 11.10 Register Description

# SAM D5x/E5x Family Data Sheet

## CMCC - Cortex M Cache Controller

### 11.10.1 Cache Type

**Name:** TYPE  
**Offset:** 0x00  
**Reset:** 0x000012D2  
**Property:** R

	31	30	29	28	27	26	25	24
	[Bit Field Diagram: 8 boxes from bit 31 to 24]							
Access								
Reset								
	23	22	21	20	19	18	17	16
	[Bit Field Diagram: 8 boxes from bit 23 to 16]							
Access								
Reset								
	15	14	13	12	11	10	9	8
	[Bit Field Diagram: 2 boxes from bit 15 to 14]		CLSIZE[2:0]			CSIZE[2:0]		
Access			R	R	R	R	R	R
Reset			0	1	0	0	1	0
	7	6	5	4	3	2	1	0
	LCKDOWN	WAYNUM[1:0]		RRP	LRUP	RANDP	GCLK	AP
Access	R	R	R	R	R	R	R	R
Reset	1	1	0	1	0	0	1	0

#### Bits 13:11 – CLSIZE[2:0] Cache Line Size

This field configures the Cache Line Size.

Value	Name	Description
0x2	CLSIZE_16B	Cache Line Size is 16 bytes
0x3–0x7	-	Reserved

#### Bits 10:8 – CSIZE[2:0] Cache Size

This bit field configures the cache size.

Value	Name	Description
0x0	CSIZE_1KB	Cache Size is 1 KB
0x1	CSIZE_2KB	Cache Size is 2 KB
0x2	CSIZE_4KB	Cache Size is 4 KB
0x3–0x7	-	Reserved

#### Bit 7 – LCKDOWN Lock Down Supported

Writing a '0' to this bit disables the Lock Down feature.

Writing a '1' to this bit enables the Lock Down feature.

Value	Description
0	Lock Down feature is not supported.
1	Lock Down feature is supported.

# SAM D5x/E5x Family Data Sheet

## CMCC - Cortex M Cache Controller

### Bits 6:5 – WAYNUM[1:0] Number of Way

This bit field configures the mapping of the cache.

Value	Name	Description
0x0	DMAPPED	Direct Mapped Cache
0x1	ARCH2WAY	2-WAY set associative
0x2	ARCH4WAY	4-WAY set associative
0x3	ARCH8WAY	8-WAY set associative

### Bit 4 – RRP Round Robin Policy Supported

Writing a '0' to this bit disables Round Robin Policy.

Writing a '1' to this bit enables Round Robin Policy.

Value	Description
0	Round Robin Policy is disabled.
1	Round Robin Policy is enabled.

### Bit 3 – LRUP Least Recently Used Policy Supported

Writing a '0' to this bit disables the Least Recently Used Policy Supported.

Writing a '1' to this bit enables the Least Recently Used Policy Supported.

### Bit 2 – RANDP Random Selection Policy Supported

Writing a '0' to this bit disables the Random Selection Policy Supported.

Writing a '1' to this bit enables the Random Selection Policy Supported.

### Bit 1 – GCLK Dynamic Clock Gating

Writing a '0' to this bit disables the Dynamic Clock Gating feature.

Writing a '1' to this bit enables the Dynamic Clock Gating feature.

Value	Description
0	Dynamic Clock Gating is disabled.
1	Dynamic Clock Gating is enabled.

### Bit 0 – AP Access Port Access Allowed

Writing a '0' to this bit disables the Access Port Access Allowed.

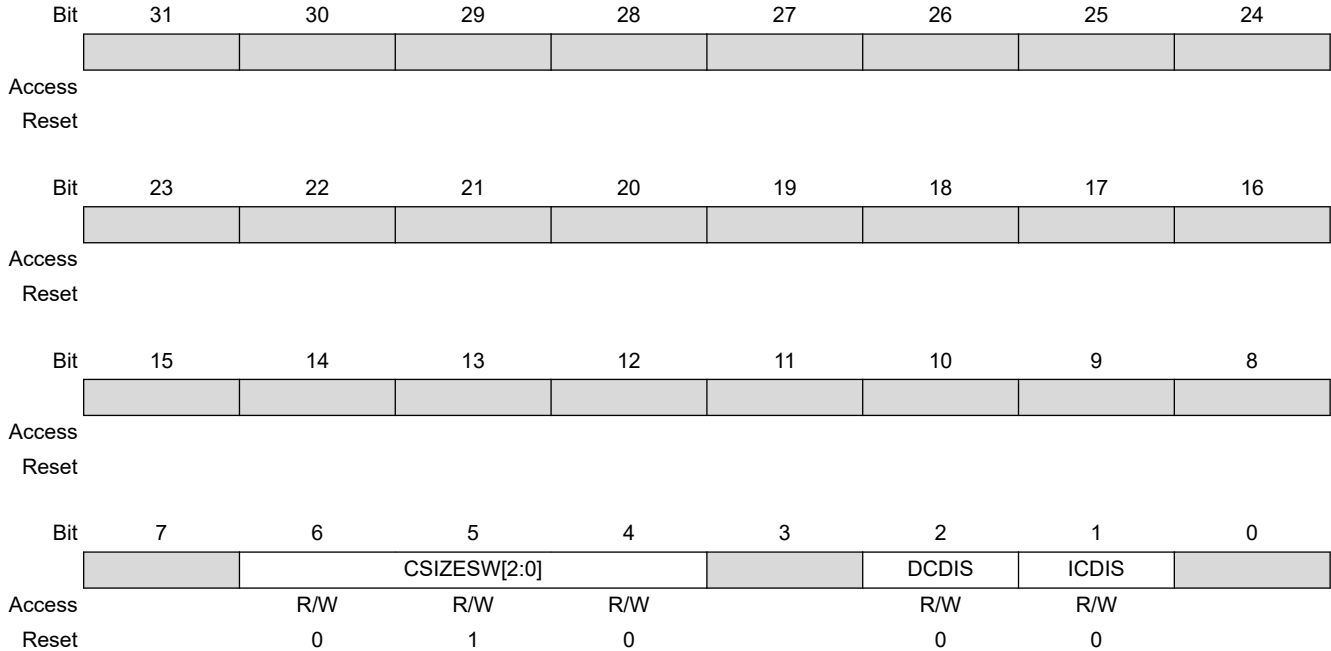
Writing a '1' to this bit enables the Access Port Access Allowed.

# SAM D5x/E5x Family Data Sheet

## CMCC - Cortex M Cache Controller

### 11.10.2 Cache Configuration

**Name:** CFG  
**Offset:** 0x04  
**Reset:** 0x00000020  
**Property:** R/W



#### Bits 6:4 – CSIZESW[2:0] Cache Size Configured by Software

This field configures the cache size.

Value	Name	Description
0x0	CONF_CSIZESW_1KB	The Cache Size is configured to 1KB
0x1	CONF_CSIZESW_2KB	The Cache Size is configured to 2KB
0x2	CONF_CSIZESW_4KB	The Cache Size is configured to 4KB
0x3	CONF_CSIZESW_8KB	The Cache Size is configured to 8KB
0x4	CONF_CSIZESW_16KB	The Cache Size is configured to 16KB
0x5	CONF_CSIZESW_32KB	The Cache Size is configured to 32KB
0x6	CONF_CSIZESW_64KB	The Cache Size is configured to 64KB
0x7		Reserved

#### Bit 2 – DCDIS Data Cache Disable

Writing a '0' to this bit enables data caching.  
 Writing a '1' to this bit disables data caching.

Value	Description
0	Data caching is enabled.
1	Data caching is disabled.

#### Bit 1 – ICDIS Instruction Cache Disable

Writing a '0' to this bit enables instruction caching.

# SAM D5x/E5x Family Data Sheet

## CMCC - Cortex M Cache Controller

Writing a '1' to this bit disables instruction caching.

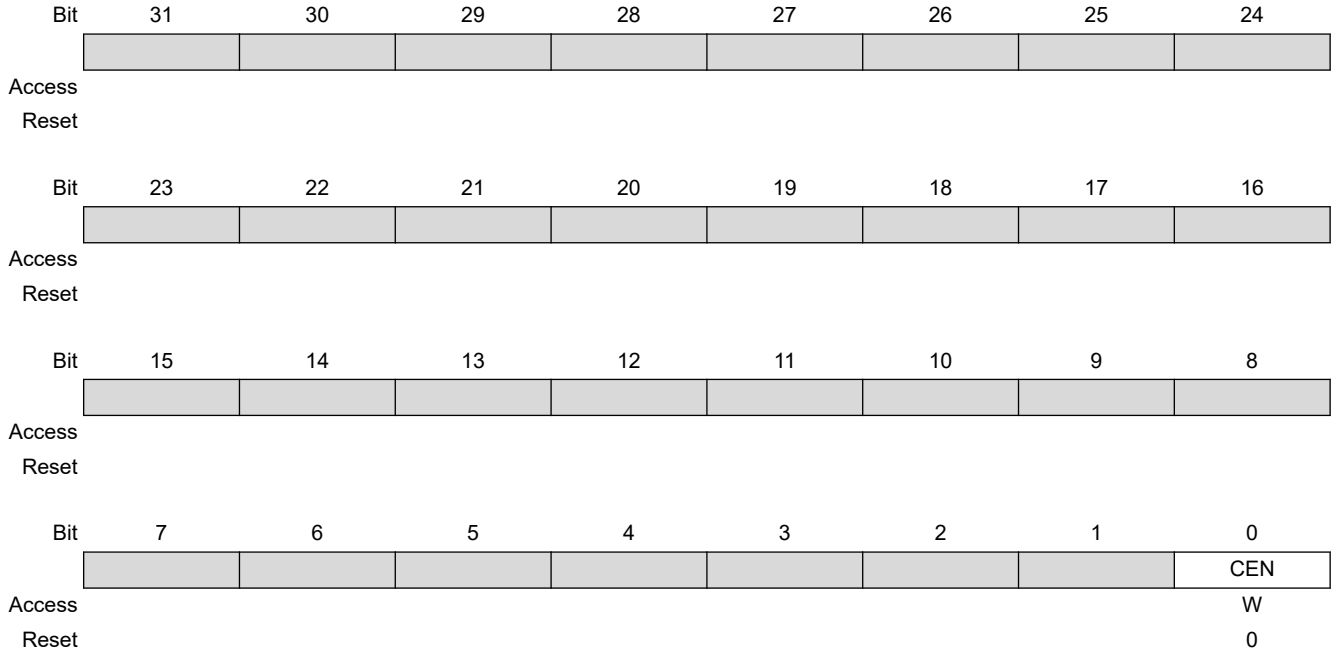
Value	Description
0	Instruction caching is enabled.
1	Instruction caching is disabled.

# SAM D5x/E5x Family Data Sheet

## CMCC - Cortex M Cache Controller

### 11.10.3 Cache Control

**Name:** CTRL  
**Offset:** 0x08  
**Reset:** 0x00000000  
**Property:** Write-only



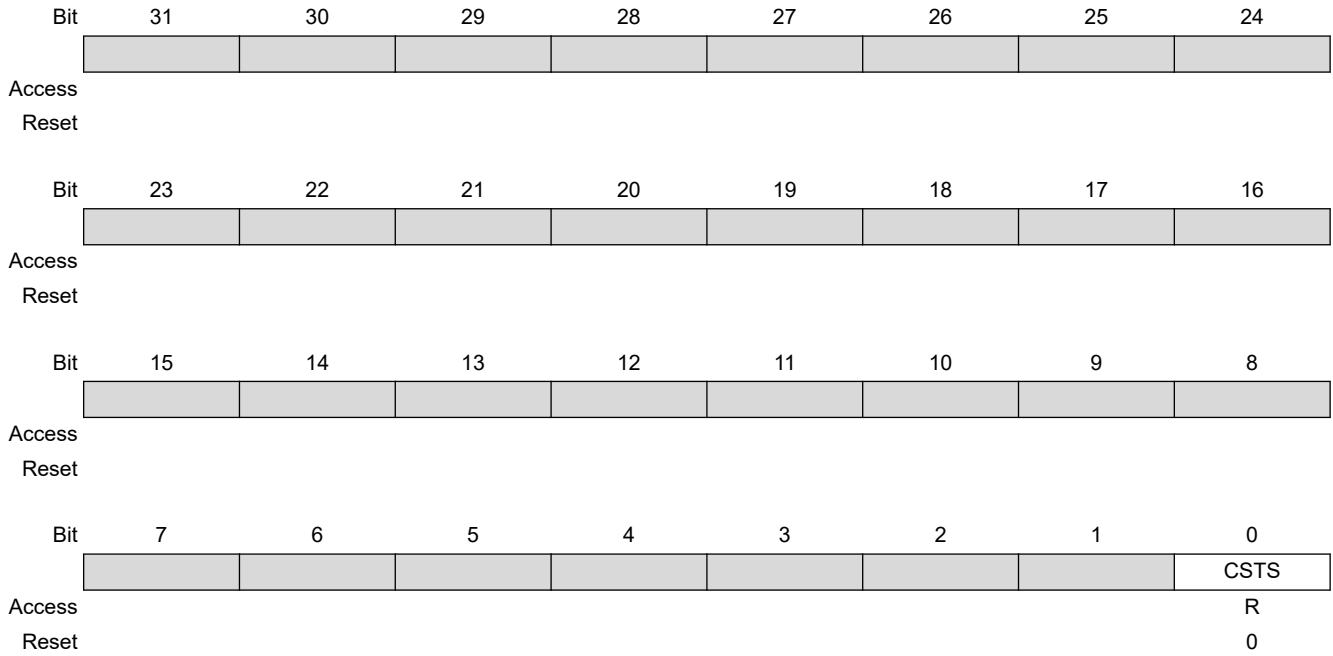
**Bit 0 – CEN** Cache Controller Enable  
Writing a '0' to this bit disables the CMCC.  
Writing a '1' to this bit enables the CMCC.

# SAM D5x/E5x Family Data Sheet

## CMCC - Cortex M Cache Controller

### 11.10.4 Cache Status

**Name:** SR  
**Offset:** 0x0C  
**Reset:** 0x00000000  
**Property:** Read-only



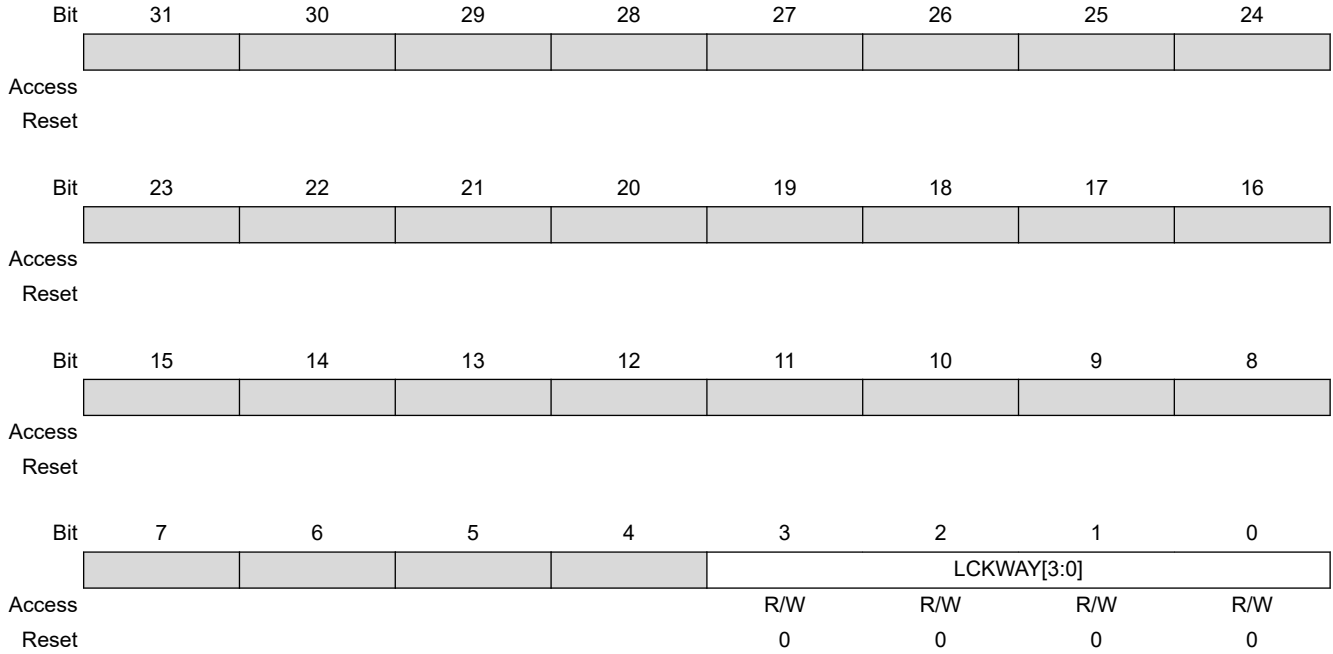
**Bit 0 – CSTS** Cache Controller Status  
 Writing to this bit has no effect.

# SAM D5x/E5x Family Data Sheet

## CMCC - Cortex M Cache Controller

### 11.10.5 Cache Lock per Way

**Name:** LCKWAY  
**Offset:** 0x10  
**Reset:** 0x00000000  
**Property:** Read/Write



**Bits 3:0 – LCKWAY[3:0]** Lockdown Way Register  
 This field selects which way is locked.

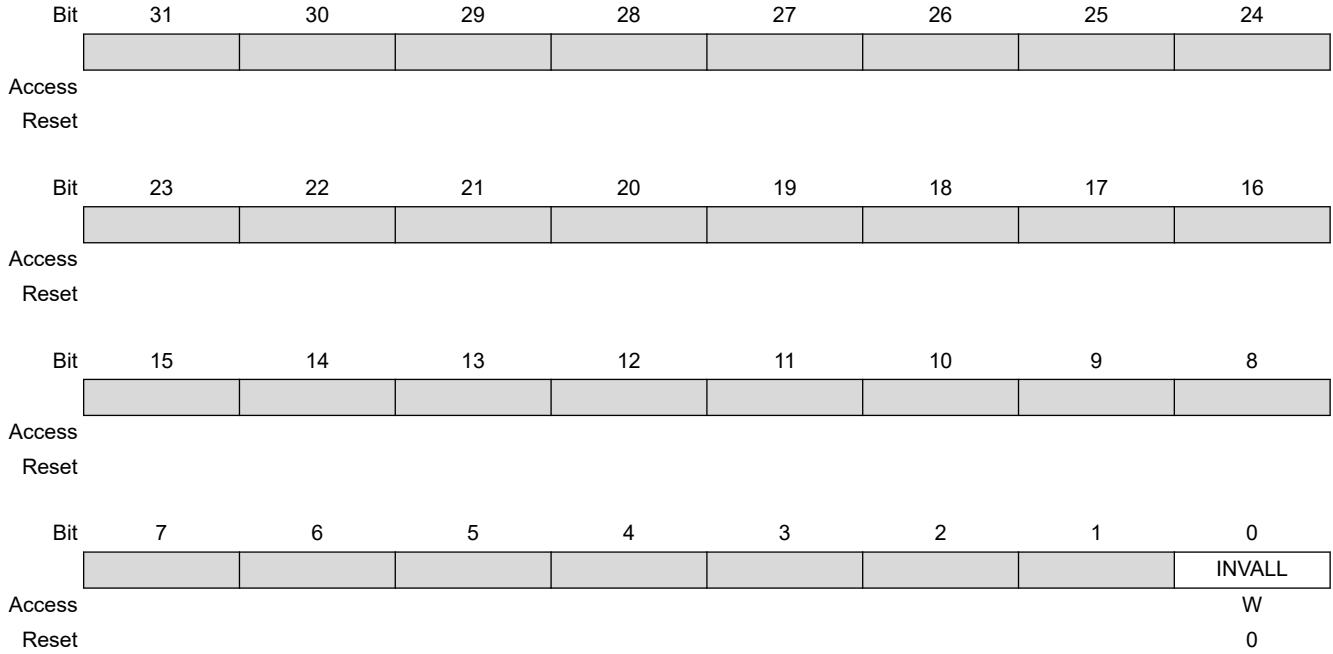


# SAM D5x/E5x Family Data Sheet

## CMCC - Cortex M Cache Controller

### 11.10.6 Cache Maintenance 0

**Name:** MAINT0  
**Offset:** 0x20  
**Reset:** 0x00000000  
**Property:** Write-only



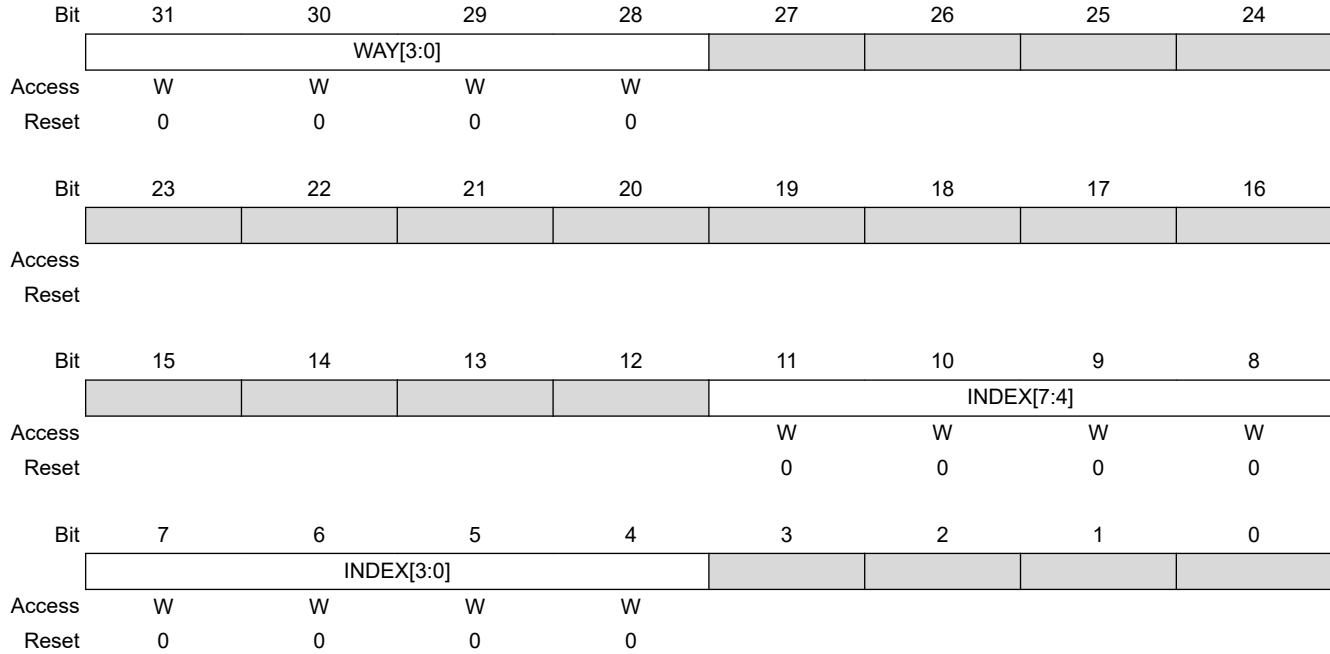
**Bit 0 – INVALL** Cache Controller Invalidate All  
 Writing a '0' to this bit has no effect.  
 Writing a '1' to this bit invalidates all cache entries.

# SAM D5x/E5x Family Data Sheet

## CMCC - Cortex M Cache Controller

### 11.10.7 Cache Maintenance 1

**Name:** MAINT1  
**Offset:** 0x24  
**Reset:** 0x00000000  
**Property:** Write-only



#### Bits 31:28 – WAY[3:0] Invalidate Way

Value	Name	Description
0x0	WAY0	Way 0 is selection for index invalidation
0x1	WAY1	Way 1 is selection for index invalidation
0x2	WAY2	Way 2 is selection for index invalidation
0x3	WAY3	Way 3 is selection for index invalidation
0x4–0xF		Reserved

#### Bits 11:4 – INDEX[7:0] Invalidate Index

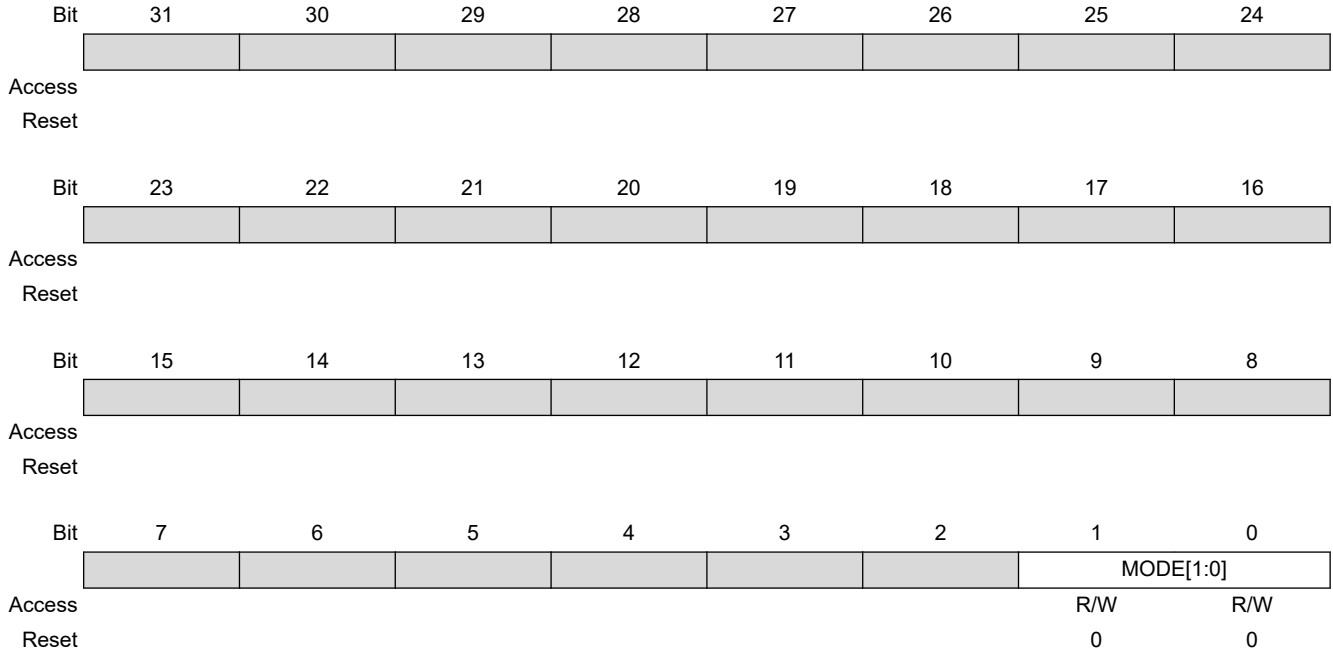
This field selects the index value for invalidation

# SAM D5x/E5x Family Data Sheet

## CMCC - Cortex M Cache Controller

### 11.10.8 Cache Monitor Configuration

**Name:** MCFG  
**Offset:** 0x28  
**Reset:** 0x00000000  
**Property:** Read/Write



#### Bits 1:0 – MODE[1:0] Cache Controller Monitor Counter Mode

This field selects the type of data monitored.

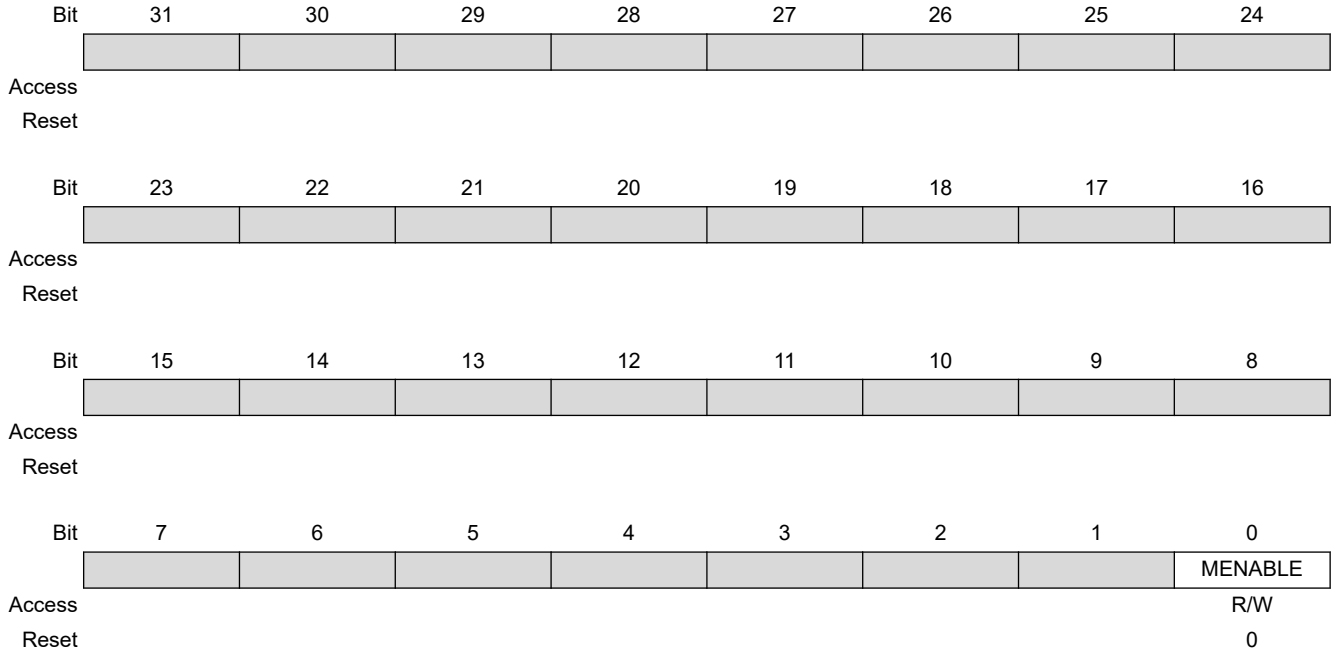
Value	Name	Description
0x0	CYCLE_COUNT	Cycle counter
0x1	IHIT_COUNT	Instruction hit counter
0x2	DHIT_COUNT	Data hit counter
0x3		Reserved

# SAM D5x/E5x Family Data Sheet

## CMCC - Cortex M Cache Controller

### 11.10.9 Cache Monitor Enable

**Name:** MEN  
**Offset:** 0x2C  
**Reset:** 0x00000000  
**Property:** Read/Write



**Bit 0 – MENABLE** Cache Controller Monitor Enable

Writing a '0' to this bit disables the monitor counter.

Writing a '1' to this bit enables the monitor counter.

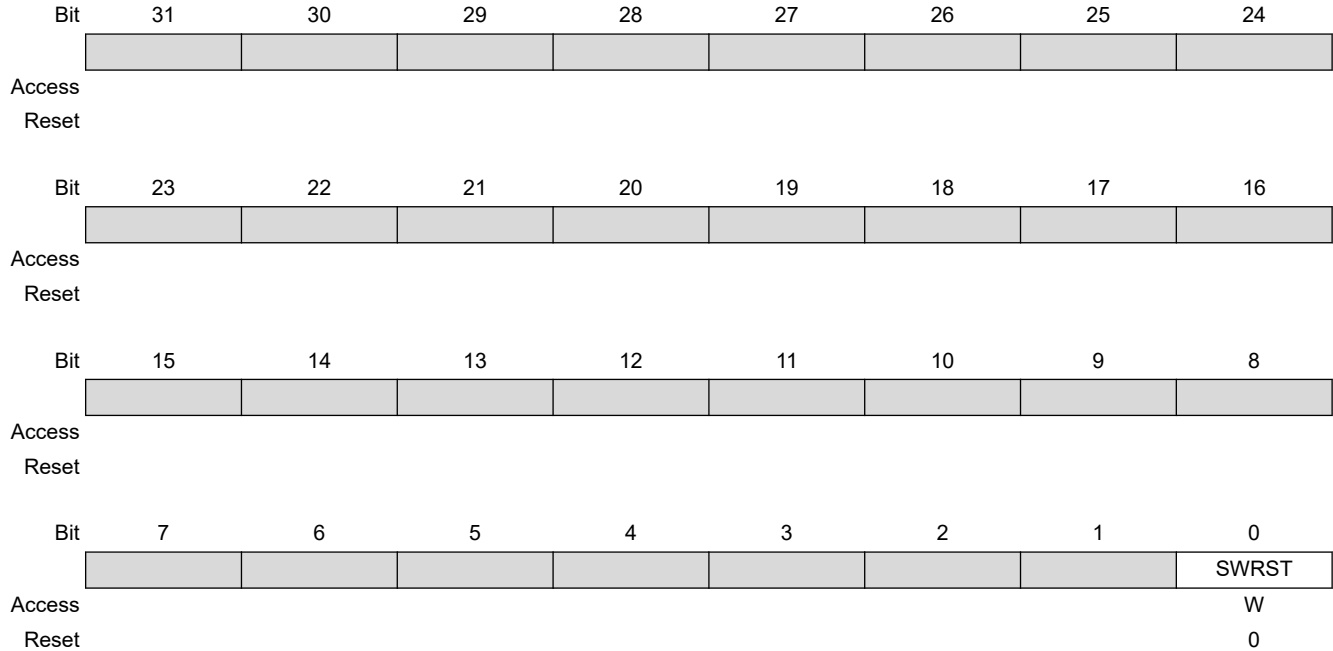
Value	Description
0	The Monitor counter is disabled.
1	The Monitor counter is enabled.

# SAM D5x/E5x Family Data Sheet

## CMCC - Cortex M Cache Controller

### 11.10.10 Cache Monitor Control

**Name:** MCTRL  
**Offset:** 0x30  
**Reset:** 0x00000000  
**Property:** Write-only



**Bit 0 – SWRST** Cache Controller Software Reset  
Writing a '0' to this bit has no effect.  
Writing a '1' to this bit resets the event counter register.

# SAM D5x/E5x Family Data Sheet

## CMCC - Cortex M Cache Controller

### 11.10.11 Cache Monitor Status

**Name:** MSR  
**Offset:** 0x34  
**Reset:** 0x00000000  
**Property:** Read-only

Bit	31	30	29	28	27	26	25	24
	EVENT_CNT[31:24]							
Access	R	R	R	R	R	R	R	R
Reset	0	0	0	0	0	0	0	0
Bit	23	22	21	20	19	18	17	16
	EVENT_CNT[23:16]							
Access	R	R	R	R	R	R	R	R
Reset	0	0	0	0	0	0	0	0
Bit	15	14	13	12	11	10	9	8
	EVENT_CNT[15:8]							
Access	R	R	R	R	R	R	R	R
Reset	0	0	0	0	0	0	0	0
Bit	7	6	5	4	3	2	1	0
	EVENT_CNT[7:0]							
Access	R	R	R	R	R	R	R	R
Reset	0	0	0	0	0	0	0	0

**Bits 31:0 – EVENT\_CNT[31:0]** Monitor Event Counter

This field indicates the Monitor Event Counter value.

## 12. DSU - Device Service Unit

### 12.1 Overview

The Device Service Unit (DSU) provides a means of detecting debugger probes. It enables the ARM Debug Access Port (DAP) to have control over multiplexed debug pads and CPU Reset. The DSU also provides system-level services to debug adapters in an ARM debug system. It implements a CoreSight Debug ROM that provides device identification as well as identification of other debug components within the system. Hence, it complies with the ARM Peripheral Identification specification. The DSU also provides system services to applications that need memory testing, as required for IEC60730 Class B compliance, for example. The DSU can be accessed simultaneously by a debugger and the CPU, as it is connected on the High-Speed Bus Matrix. For security reasons, some of the DSU features will be limited or unavailable when the device is protected by the NVMCTRL security bit.

#### Related Links

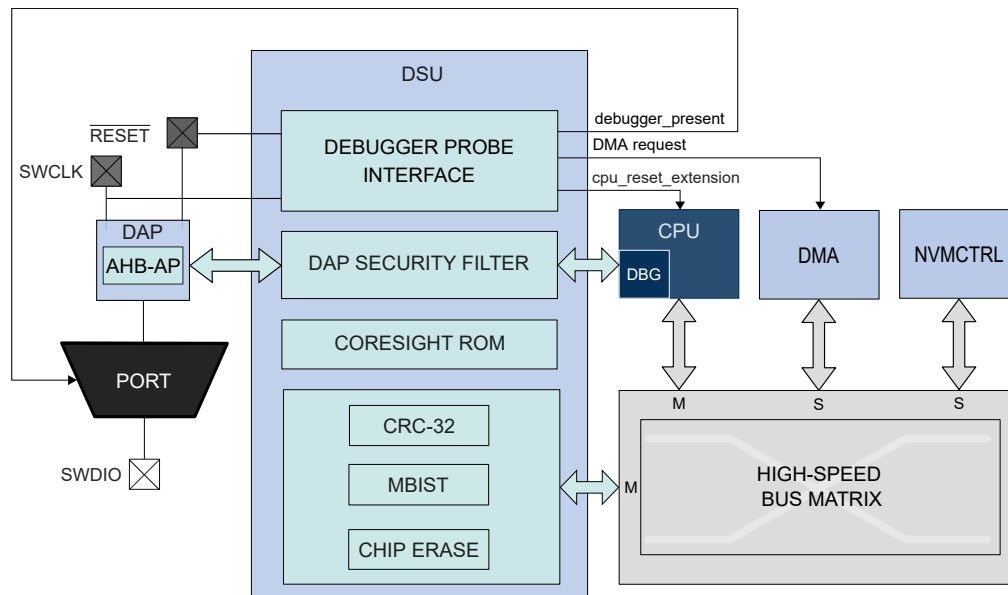
[25. NVMCTRL – Nonvolatile Memory Controller](#)

### 12.2 Features

- CPU Reset Extension
- Debugger Probe Detection (Cold- and Hot-Plugging)
- Chip-Erase Command and Status
- 32-Bit Cyclic Redundancy Check (CRC32) of any Memory Accessible Through the Bus Matrix
- ARM® CoreSight™ Compliant Device Identification
- Two Debug Communications Channels with DMA Connection
- Debug Access Port Security Filter
- Onboard Memory Built-in Self-test (MBIST)

### 12.3 Block Diagram

Figure 12-1. DSU Block Diagram



### 12.4 Signal Description

The DSU uses three signals to function.

Signal Name	Type	Description
RESET	Digital Input	External Reset
SWCLK	Digital Input	SW clock
SWDIO	Digital I/O	SW bidirectional data pin

#### Related Links

[6. I/O Multiplexing and Considerations](#)

### 12.5 Product Dependencies

In order to use this peripheral, other parts of the system must be configured correctly, as described below.

#### 12.5.1 I/O Lines

The SWCLK pin is by default assigned to the DSU module to allow debugger probe detection and to stretch the CPU Reset phase. For more information, refer to [12.6.3 Debugger Probe Detection](#). The Hot-Plugging feature depends on the PORT configuration. If the SWCLK pin function is changed in the port or if the PORT\_MUX is disabled, the Hot-Plugging feature is disabled until a power reset or an external Reset is performed.

#### 12.5.2 Power Management

The DSU will continue to operate in Idle mode.



### Related Links

[18. PM – Power Manager](#)

### 12.5.3 Clocks

The DSU bus clocks (CLK\_DSU\_APB and CLK\_DSU\_AHB) can be enabled and disabled by the Main Clock Controller.

### Related Links

[18. PM – Power Manager](#)

[15. MCLK – Main Clock](#)

[15.6.2.6 Peripheral Clock Masking](#)

### 12.5.4 DMA

The DMA request lines are connected to the DMA Controller (DMAC). In order to use DMA requests with this peripheral the DMAC must be configured first. Refer to DMAC – Direct Memory Access Controller for details.

### Related Links

[22. DMAC – Direct Memory Access Controller](#)

### 12.5.5 Interrupts

Not applicable.

### 12.5.6 Events

Not applicable.

### 12.5.7 Register Access Protection

Registers with write access can be optionally write-protected by the Peripheral Access Controller (PAC), except for the following:

- Debug Communication Channel 0 register (DCC0)
- Debug Communication Channel 1 register (DCC1)

**Note:** Optional write protection is indicated by the "PAC Write Protection" property in the register description.

Write protection does not apply for accesses through an external debugger.

### Related Links

[27. PAC - Peripheral Access Controller](#)

### 12.5.8 Analog Connections

Not applicable.

## 12.6 Debug Operation

### 12.6.1 Principle of Operation

The DSU provides basic services to allow on-chip debug using the ARM Debug Access Port and the ARM processor debug resources:

- CPU Reset extension

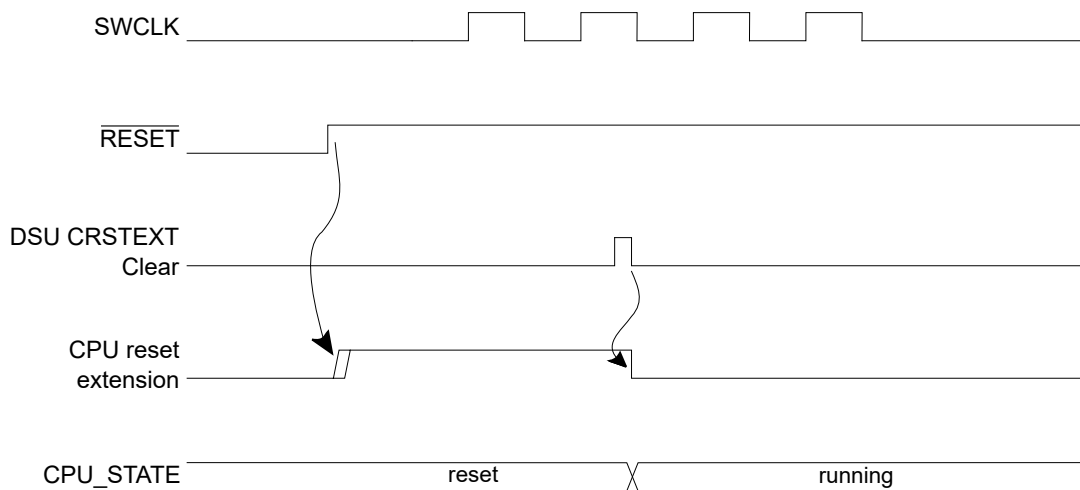
- Debugger probe detection

For more details on the ARM debug components, refer to the ARM Debug Interface v5 Architecture Specification.

### 12.6.2 CPU Reset Extension

“CPU Reset extension” refers to the extension of the Reset phase of the CPU core after the external Reset is released. This ensures that the CPU is not executing code at start-up while a debugger is connects to the system. The debugger is detected on a  $\overline{\text{RESET}}$  release event when SWCLK is low. At start-up, SWCLK is internally pulled up to avoid false detection of a debugger if the SWCLK pin is left unconnected. When the CPU is held in the Reset extension phase, the CPU Reset Extension bit of the Status A register (STATUSA.CRSTEXT) is set. To release the CPU, write a '1' to STATUSA.CRSTEXT. STATUSA.CRSTEXT will then be set to '0'. Writing a '0' to STATUSA.CRSTEXT has no effect. For security reasons, it is not possible to release the CPU Reset extension when the device is protected by the NVMCTRL security bit. Trying to do so sets the Protection Error bit (PERR) of the Status A register (STATUSA.PERR).

**Figure 12-2. Typical CPU Reset Extension Set and Clear Timing Diagram**



#### Related Links

[25. NVMCTRL – Nonvolatile Memory Controller](#)

### 12.6.3 Debugger Probe Detection

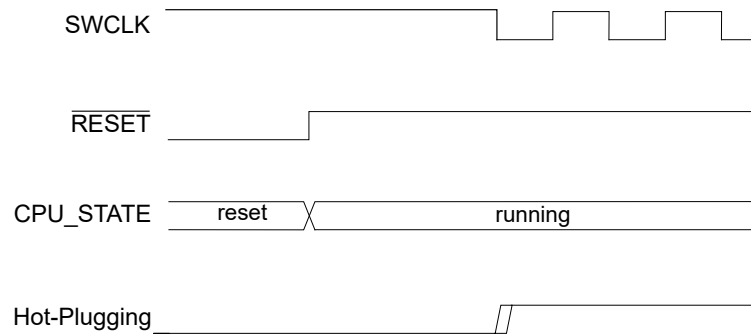
#### 12.6.3.1 Cold Plugging

Cold-Plugging is the detection of a debugger when the system is in Reset. Cold-Plugging is detected when the CPU Reset extension is requested, as described above.

#### 12.6.3.2 Hot Plugging

Hot-Plugging is the detection of a debugger probe when the system is not in Reset. Hot-Plugging is not possible under Reset because the detector is reset when POR or  $\overline{\text{RESET}}$  are asserted. Hot-Plugging is active when a SWCLK falling edge is detected. The SWCLK pad is multiplexed with other functions and the user must ensure that its default function is assigned to the debug system. If the SWCLK function is changed, the Hot-Plugging feature is disabled until a power reset or external Reset occurs. Availability of the Hot-Plugging feature can be read from the Hot-Plugging Enable bit of the Status B register (STATUSB.HPE).

**Figure 12-3. Hot-Plugging Detection Timing Diagram**



The presence of a debugger probe is detected when either Hot-Plugging or Cold-Plugging is detected. Once detected, the Debugger Present bit of the Status B register (STATUSB.DBGPRES) is set. For security reasons, Hot-Plugging is not available when the device is protected by the NVMCTRL security bit.

This detection requires that pads are correctly powered. Thus, at cold start-up, this detection cannot be done until POR is released. If the device is protected, Cold-Plugging is the only way to detect a debugger probe, and so the external Reset timing must be longer than the POR timing. If external Reset is deasserted before POR release, the user must retry the procedure above until it gets connected to the device.

### Related Links

[25. NVMCTRL – Nonvolatile Memory Controller](#)

## 12.7 Chip Erase

Chip erase consists of removing all sensitive information stored in the chip and clearing the NVMCTRL security bit. Therefore, all volatile memories and the Flash memory (including the EEPROM emulation area) will be erased. The Flash auxiliary rows, including the user row, will not be erased.

When the device is protected, the debugger must first reset the device in order to be detected. This ensures that internal registers are reset after the Protected state is removed. The chip erase operation is triggered by writing a '1' to the chip erase bit in the Control register (CTRL.CE). This command will be discarded if the DSU is protected by the Peripheral Access Controller (PAC). Once issued, the module clears volatile memories prior to erasing the Flash array. To ensure that the chip erase operation is completed, check the Done bit of the Status A register (STATUSA.DONE).

The chip erase operation depends on clocks and power management features that can be altered by the CPU. For that reason, it is recommended to issue a chip erase after a Cold-Plugging procedure to ensure that the device is in a known and Safe state.

The recommended sequence is as follows:

1. Issue the Cold-Plugging procedure (refer to [12.6.3.1 Cold Plugging](#)). The device then:
  - 1.1. Detects the debugger probe.
  - 1.2. Holds the CPU in Reset.
2. Issue the chip erase command by writing a '1' to CTRL.CE. The device then:
  - 2.1. Clears the system volatile memories.
  - 2.2. Erases the whole Flash array (including the EEPROM emulation area, not including auxiliary rows).

- 2.3. Erases the lock row, removing the NVMCTRL security bit protection.
3. Check for completion by polling STATUSA.DONE (read as '1' when completed).
4. Reset the device to let the NVMCTRL update the fuses.

## 12.8 Programming

Programming the Flash or RAM memories is only possible when the device is not protected by the NVMCTRL security bit. The programming procedure is as follows:

1. At power-up,  $\overline{\text{RESET}}$  is driven low by a debugger. The on-chip regulator holds the system in a POR state until the input supply is above the POR threshold (refer to Power-on Reset (POR) characteristics). The system continues to be held in this Static state until the internally regulated supplies have reached a safe Operating state.
2. The PM starts, clocks are switched to the slow clock (Core Clock, System Clock, Flash Clock and any Bus Clocks that do not have clock gate control). Internal Resets are maintained due to the external Reset.
3. The debugger maintains a low level on SWCLK.  $\overline{\text{RESET}}$  is released, resulting in a debugger Cold-Plugging procedure.
4. The debugger generates a clock signal on the SWCLK pin, the Debug Access Port (DAP) receives a clock.
5. The CPU remains in Reset due to the Cold-Plugging procedure; meanwhile, the rest of the system is released.
6. A chip erase is issued to ensure that the Flash is fully erased prior to programming.
7. Programming is available through the AHB-AP.
8. After the operation is completed, the chip can be restarted either by asserting  $\overline{\text{RESET}}$  or toggling power. Make sure that the SWCLK pin is high when releasing  $\overline{\text{RESET}}$  to prevent extending the CPU Reset.

### Related Links

[25. NVMCTRL – Nonvolatile Memory Controller](#)

## 12.9 Intellectual Property Protection

Intellectual property protection consists of restricting access to internal memories from external tools when the device is protected, and this is accomplished by setting the NVMCTRL security bit. This Protected state can be removed by issuing a chip erase (refer to [12.7 Chip Erase](#)). When the device is protected, read/write accesses using the AHB-AP are limited to the DSU address range and DSU commands are restricted. When issuing a chip erase, sensitive information is erased from volatile memory and Flash.

The DSU implements a security filter that monitors the AHB transactions inside the DAP. If the device is protected, then AHB-AP read/write accesses outside the DSU external address range are discarded, causing an error response that sets the ARM AHB-AP sticky error bits (refer to the ARM Debug Interface v5 Architecture Specification on <http://www.arm.com>).

The DSU is intended to be accessed either:

- Internally from the CPU, without any limitation, even when the device is protected
- Externally from a debug adapter, with some restrictions when the device is protected

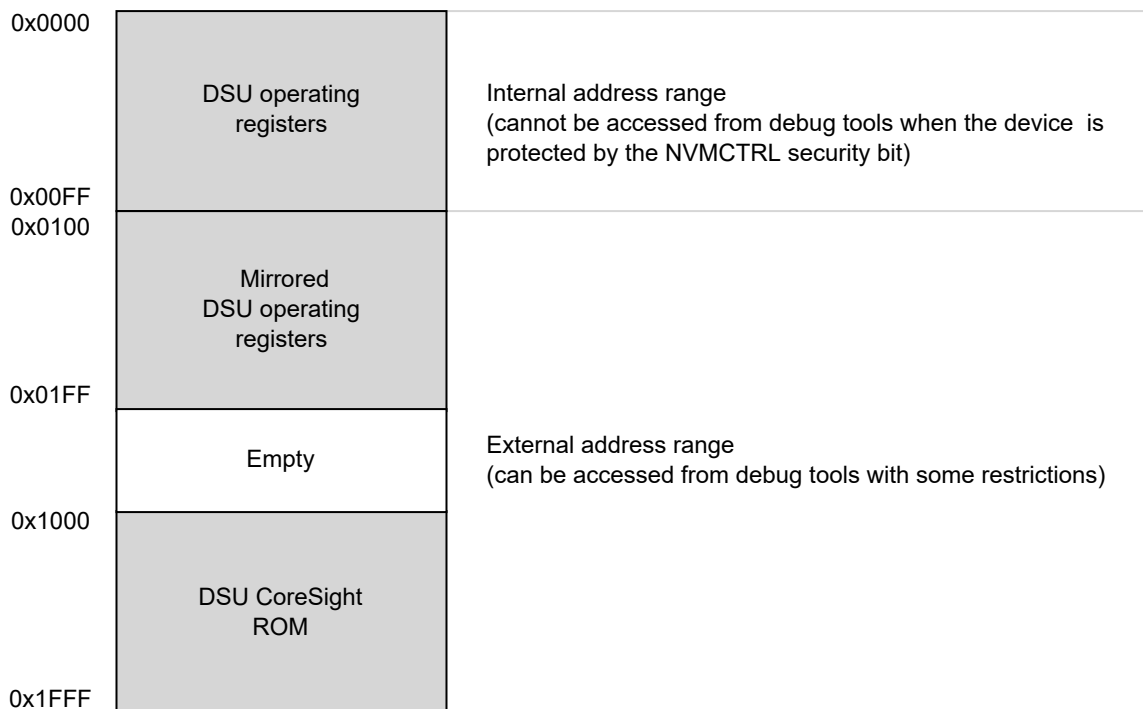
For security reasons, DSU features have limitations when used from a debug adapter. To differentiate external accesses from internal ones, the first 0x100 bytes of the DSU register map has been mirrored at offset 0x100:

- The first 0x100 bytes form the internal address range
- The next 0x100 bytes form the external address range

When the device is protected, the DAP can only issue MEM-AP accesses in the DSU range 0x0100-0x2000.

The DSU Operating registers are located in the 0x0000-0x00FF area and remapped in 0x0100-0x01FF to differentiate accesses coming from a debugger and the CPU. If the device is protected and an access is issued in the region 0x0100-0x01FF, it is subject to security restrictions. For more information, refer to [Table 12-1](#).

**Figure 12-4. APB Memory Mapping**



Some features not activated by APB transactions are not available when the device is protected:

**Table 12-1. Feature Availability Under Protection**

Features	Availability When the Device is Protected
CPU Reset Extension	Yes
Clear CPU Reset Extension	No
Debugger Cold-Plugging	Yes
Debugger Hot-Plugging	No

### Related Links

[25. NVMCTRL – Nonvolatile Memory Controller](#)

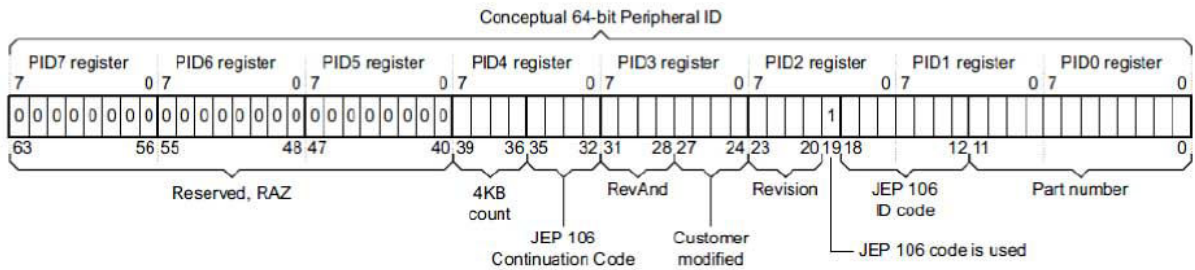
### 12.10 Device Identification

Device identification relies on the ARM CoreSight component identification scheme, which allows the chip to be identified as a SAM device implementing a DSU. The DSU contains identification registers to differentiate the device.

#### 12.10.1 CoreSight Identification

A system-level ARM® CoreSight™ ROM table is present in the device to identify the vendor and the chip identification method. Its address is provided in the MEM-AP BASE register inside the ARM Debug Access Port. The CoreSight ROM implements a 64-bit conceptual ID composed as follows from the PID0 to PID7 CoreSight ROM Table registers:

**Figure 12-5. Conceptual 64-bit Peripheral ID**



**Table 12-2. Conceptual 64-Bit Peripheral ID Bit Descriptions**

Field	Size	Description	Location
JEP-106 CC code	4	Continuation code: 0x0	PID4
JEP-106 ID code	7	Device ID: 0x1F	PID1+PID2
4KB count	4	Indicates that the CoreSight component is a ROM: 0x0	PID4
RevAnd	4	Not used; read as 0	PID3
CUSMOD	4	Not used; read as 0	PID3
PARTNUM	12	Contains 0xCD0 to indicate that DSU is present	PID0+PID1
REVISION	4	DSU revision (starts at 0x0 and increments by 1 at both major and minor revisions). Identifies DSU identification method variants. If 0x0, this indicates that device identification can be completed by reading the Device Identification register (DID)	PID2

For more information, refer to the ARM Debug Interface Version 5 Architecture Specification.

#### 12.10.2 Chip Identification Method

The DSU DID register identifies the device by implementing the following information:

- Processor identification
- Product family identification
- Product series identification
- Device select

## 12.11 Functional Description

### 12.11.1 Principle of Operation

The DSU provides memory services, such as CRC32 or MBIST that require almost the same interface. Hence, the Address, Length and Data registers (ADDR, LENGTH, DATA) are shared. These shared registers must be configured first; then a command can be issued by writing the Control register. When a command is ongoing, other commands are discarded until the current operation is completed. Hence, the user must wait for the STATUSA.DONE bit to be set prior to issuing another one.

### 12.11.2 Basic Operation

#### 12.11.2.1 Initialization

The module is enabled by enabling its clocks. For more details, refer to [12.5.3 Clocks](#). The DSU registers can be PAC write-protected.

#### Related Links

[27. PAC - Peripheral Access Controller](#)

#### 12.11.2.2 Operation From a Debug Adapter

Debug adapters should access the DSU registers in the external address range 0x100 – 0x2000. If the device is protected by the NVMCTRL security bit, accessing the first 0x100 bytes causes the system to return an error. Refer to [12.9 Intellectual Property Protection](#).

#### Related Links

[25. NVMCTRL – Nonvolatile Memory Controller](#)

#### 12.11.2.3 Operation From the CPU

There are no restrictions when accessing DSU registers from the CPU. However, the user should access DSU registers in the internal address range (0x0 – 0x100) to avoid external security restrictions. Refer to [12.9 Intellectual Property Protection](#).

### 12.11.3 32-bit Cyclic Redundancy Check CRC32

The DSU unit provides support for calculating a cyclic redundancy check (CRC32) value for a memory area (including Flash and AHB RAM).

When the CRC32 command is issued from:

- The internal range, the CRC32 can be operated at any memory location
- The external range, the CRC32 operation is restricted; DATA, ADDR, and LENGTH values are forced (see below)

**Table 12-3. AMOD Bit Descriptions when Operating CRC32**

AMOD[1:0]	Short name	External range restrictions
0	ARRAY	CRC32 is restricted to the full Flash array area (EEPROM emulation area not included) DATA forced to 0xFFFFFFFF before calculation (no seed)
1	EEPROM	CRC32 of the whole EEPROM emulation area DATA forced to 0xFFFFFFFF before calculation (no seed)
2-3	Reserved	

---

The algorithm employed is the industry standard CRC32 algorithm using the generator polynomial 0xEDB88320 (reversed representation).

### 12.11.3.1 Starting CRC32 Calculation

CRC32 calculation for a memory range is started after writing the start address into the Address register (ADDR) and the size of the memory range into the Length register (LENGTH). Both must be word-aligned.

The initial value used for the CRC32 calculation must be written to the Data register (DATA). This value will usually be 0xFFFFFFFF, but can be, for example, the result of a previous CRC32 calculation if generating a common CRC32 of separate memory blocks.

Once completed, the calculated CRC32 value can be read out of the Data register. The read value must be complemented to match standard CRC32 implementations or kept noninverted if used as starting point for subsequent CRC32 calculations.

The actual test is started by writing a '1' in the 32-bit Cyclic Redundancy Check bit of the Control register (CTRL.CRC). A running CRC32 operation can be canceled by resetting the module (writing '1' to CTRL.SWRST).

#### Related Links

[25. NVMCTRL – Nonvolatile Memory Controller](#)

### 12.11.3.2 Interpreting the Results

The user should monitor the Status A register. When the operation is completed, STATUSA.DONE is set. Then the Bus Error bit of the Status A register (STATUSA.BERR) must be read to ensure that no bus error occurred.

### 12.11.4 Debug Communication Channels

The Debug Communication Channels (DCC0 and DCC1) consist of a pair of registers with associated handshake logic, accessible by both CPU and debugger even if the device is protected by the NVMCTRL security bit. The registers can be used to exchange data between the CPU and the debugger, during run time as well as in Debug mode. This enables the user to build a custom debug protocol using only these registers.

The DCC0 and DCC1 registers are accessible when the Protected state is active. When the device is protected, however, it is not possible to connect a debugger while the CPU is running (STATUSA.CRSTEXT is not writable and the CPU is held under Reset).

Two Debug Communication Channel status bits in the Status B registers (STATUS.DCCDx) indicate whether a new value has been written in DCC0 or DCC1. These bits, DCC0D and DCC1D, are located in the STATUSB registers. They are automatically set on write and cleared on read.

**Note:** The DCC0 and DCC1 registers are shared with the on-board memory testing logic (MBIST). Accordingly, DCC0 and DCC1 must not be used while performing MBIST operations.

#### Related Links

[25. NVMCTRL – Nonvolatile Memory Controller](#)

### 12.11.5 Debug Communication Channels DMA connection

The DCC0 and DCC1 registers can be used as a source or a destination of a DMA channel. The DSU generates one DMA request per Debug Communication Channels. The level of this DMA request is selectable writing the CFG.DCCDMALEVELx bit. Writing a 0 to this bit will configure the DMA request to



---

---

trig on DCCx register empty. Writing a 1 to this bit will configure the DMA request to trig on DCCx register full.

### 12.11.6 Testing of On-Board Memories MBIST

The DSU implements a feature for automatic testing of memory, also known as MBIST (memory built-in self test). This is primarily intended for production test of on-board memories. MBIST cannot be operated from the external address range when the device is protected by the NVMCTRL security bit. If an MBIST command is issued when the device is protected, a protection error is reported in the Protection Error bit in the Status A register (STATUSA.PERR).

#### 1. Algorithm

The algorithm used for testing is a type of March algorithm called "March LR". This algorithm is able to detect a wide range of memory defects, while still keeping a linear run time. The algorithm is:

- 1.1. Write entire memory to '0', in any order.
- 1.2. Bit by bit read '0', write '1', in descending order.
- 1.3. Bit by bit read '1', write '0', read '0', write '1', in ascending order.
- 1.4. Bit by bit read '1', write '0', in ascending order.
- 1.5. Bit by bit read '0', write '1', read '1', write '0', in ascending order.
- 1.6. Read '0' from entire memory, in ascending order.

The specific implementation used as a run time which depends on the CPU clock frequency and the number of bytes tested in the RAM. The detected faults are:

- Address decoder faults
- Stuck-at faults
- Transition faults
- Coupling faults
- Linked Coupling faults

#### 2. Starting MBIST

To test a memory, you need to write the start address of the memory to the ADDR.ADDR bit field, and the size of the memory into the Length register.

For best test coverage, an entire physical memory block should be tested at once. It is possible to test only a subset of a memory, but the test coverage will then be somewhat lower.

The actual test is started by writing a '1' to CTRL.MBIST. A running MBIST operation can be canceled by writing a '1' to CTRL.SWRST.

#### 3. Interpreting the Results

The tester should monitor the STATUSA register. When the operation is completed, STATUSA.DONE is set. There are two different modes:

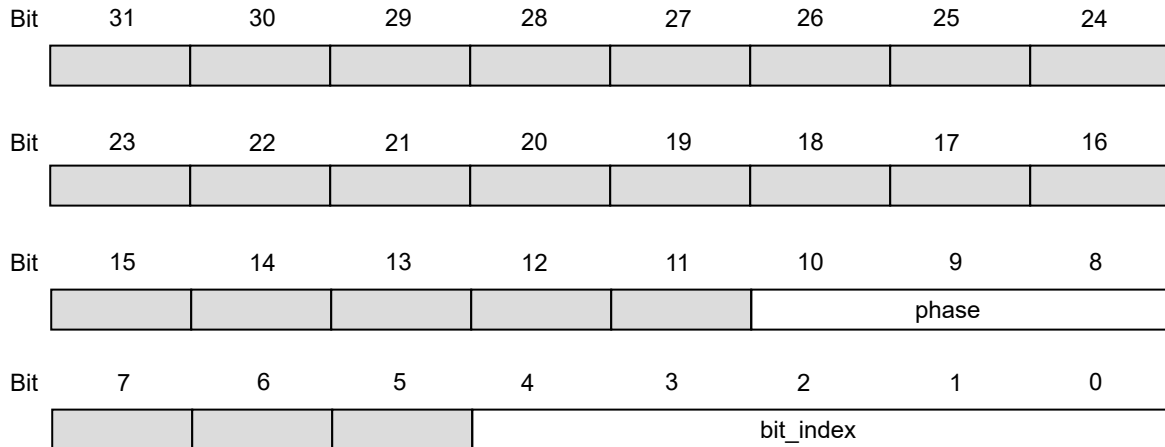
- ADDR.AMOD=0: exit-on-error (default)  
In this mode, the algorithm terminates either when a fault is detected or on successful completion. In both cases, STATUSA.DONE is set. If an error was detected, STATUSA.FAIL will be set. User then can read the DATA and ADDR registers to locate the fault.
- ADDR.AMOD=1: pause-on-error  
In this mode, the MBIST algorithm is paused when an error is detected. In such a situation, only STATUSA.FAIL is asserted. The state machine waits for user to clear STATUSA.FAIL by writing a '1' in STATUSA.FAIL to resume. Prior to resuming, user can read the DATA and ADDR registers to locate the fault.

#### 4. Locating Faults

If the test stops with STATUSA.FAIL set, one or more bits failed the test. The test stops at the first detected error. The position of the failing bit can be found by reading the following registers:

- ADDR: Address of the word containing the failing bit
- DATA: contains data to identify which bit failed, and during which phase of the test it failed. The DATA register will in this case contains the following bit groups:

**Figure 12-6. DATA bits Description When MBIST Operation Returns an Error**



- bit\_index: contains the bit number of the failing bit
- phase: indicates which phase of the test failed and the cause of the error, as listed in the following table.

**Table 12-4. MBIST Operation Phases**

Phase	Test actions
0	Write all bits to zero. This phase cannot fail.
1	Read '0', write '1', increment address
2	Read '1', write '0'
3	Read '0', write '1', decrement address
4	Read '1', write '0', decrement address
5	Read '0', write '1'
6	Read '1', write '0', decrement address
7	Read all zeros. bit_index is not used

**Table 12-5. AMOD Bit Descriptions for MBIST**

AMOD[1:0]	Description
0x0	Exit on Error
0x1	Pause on Error
0x2, 0x3	Reserved

### Related Links

[25. NVMCTRL – Nonvolatile Memory Controller](#)

[8. Product Memory Mapping Overview](#)

### 12.11.7 System Services Availability when Accessed Externally and Device is Protected

External access: Access performed in the DSU address offset 0x200-0x1FFF range.

Internal access: Access performed in the DSU address offset 0x000-0x100 range.

**Table 12-6. Available Features when Operated From The External Address Range and Device is Protected**

Features	Availability From The External Address Range and Device is Protected
Chip erase command and status	Yes
CRC32	Yes, only full array or full EEPROM
CoreSight Compliant Device identification	Yes
Debug communication channels	Yes
Testing of onboard memories (MBIST)	No
STATUSA.CRSTEXT clearing	No (STATUSA.PERR is set when attempting to do so)

# SAM D5x/E5x Family Data Sheet

## DSU - Device Service Unit

### 12.12 Register Summary

Offset	Name	Bit Pos.										
0x00	CTRL	7:0				CE	MBIST	CRC		SWRST		
0x01	STATUSA	7:0				PERR	FAIL	BERR	CRSTEXT	DONE		
0x02	STATUSB	7:0			CELCK	HPE	DCCD1	DCCD0	DBGPRES	PROT		
0x03	Reserved											
0x04	ADDR	7:0	ADDR[5:0]						AMOD[1:0]			
		15:8	ADDR[13:6]									
		23:16	ADDR[21:14]									
		31:24	ADDR[29:22]									
0x08	LENGTH	7:0	LENGTH[5:0]									
		15:8	LENGTH[13:6]									
		23:16	LENGTH[21:14]									
		31:24	LENGTH[29:22]									
0x0C	DATA	7:0	DATA[7:0]									
		15:8	DATA[15:8]									
		23:16	DATA[23:16]									
		31:24	DATA[31:24]									
0x10	DCC0	7:0	DATA[7:0]									
		15:8	DATA[15:8]									
		23:16	DATA[23:16]									
		31:24	DATA[31:24]									
0x14	DCC1	7:0	DATA[7:0]									
		15:8	DATA[15:8]									
		23:16	DATA[23:16]									
		31:24	DATA[31:24]									
0x18	DID	7:0	DEVSEL[7:0]									
		15:8	DIE[3:0]			REVISION[3:0]						
		23:16	FAMILY[0:0]	SERIES[5:0]								
		31:24	PROCESSOR[3:0]			FAMILY[4:1]						
0x1C	CFG	7:0				ETBRAMEN	DCCDMALEVEL[1:0]		LQOS[1:0]			
		15:8										
		23:16										
		31:24										
0x20 ... 0xEF	Reserved											
0xF0	DCFG0	7:0	DCFG[7:0]									
		15:8	DCFG[15:8]									
		23:16	DCFG[23:16]									
		31:24	DCFG[31:24]									
0xF4	DCFG1	7:0	DCFG[7:0]									
		15:8	DCFG[15:8]									
		23:16	DCFG[23:16]									
		31:24	DCFG[31:24]									

# SAM D5x/E5x Family Data Sheet

## DSU - Device Service Unit

.....continued

Offset	Name	Bit Pos.								
0xF8 ... 0x0FFF	Reserved									
0x1000	ENTRY0	7:0						FMT	EPRES	
		15:8	ADDOFF[3:0]							
		23:16				ADDOFF[11:4]				
		31:24				ADDOFF[19:12]				
0x1004	ENTRY1	7:0						FMT	EPRES	
		15:8	ADDOFF[3:0]							
		23:16				ADDOFF[11:4]				
		31:24				ADDOFF[19:12]				
0x1008	END	7:0				END[7:0]				
		15:8				END[15:8]				
		23:16				END[23:16]				
		31:24				END[31:24]				
0x100C ... 0x1FCB	Reserved									
0x1FCC	MEMTYPE	7:0							SMEMP	
		15:8								
		23:16								
		31:24								
0x1FD0	PID4	7:0	FKBC[3:0]			JEPCC[3:0]				
		15:8								
		23:16								
		31:24								
0x1FD4	PID5	7:0								
		15:8								
		23:16								
		31:24								
0x1FD8	PID6	7:0								
		15:8								
		23:16								
		31:24								
0x1FDC	PID7	7:0								
		15:8								
		23:16								
		31:24								
0x1FE0	PID0	7:0	PARTNBL[7:0]							
		15:8								
		23:16								
		31:24								

# SAM D5x/E5x Family Data Sheet

## DSU - Device Service Unit

.....continued

Offset	Name	Bit Pos.							
0x1FE4	PID1	7:0	JEPIDCL[3:0]			PARTNBH[3:0]			
		15:8							
		23:16							
		31:24							
0x1FE8	PID2	7:0	REVISION[3:0]		JEPU	JEPIDCH[2:0]			
		15:8							
		23:16							
		31:24							
0x1FEC	PID3	7:0	REVAND[3:0]			CUSMOD[3:0]			
		15:8							
		23:16							
		31:24							
0x1FF0	CID0	7:0	PREAMBLEB0[7:0]						
		15:8							
		23:16							
		31:24							
0x1FF4	CID1	7:0	CCLASS[3:0]			PREAMBLE[3:0]			
		15:8							
		23:16							
		31:24							
0x1FF8	CID2	7:0	PREAMBLEB2[7:0]						
		15:8							
		23:16							
		31:24							
0x1FFC	CID3	7:0	PREAMBLEB3[7:0]						
		15:8							
		23:16							
		31:24							

### 12.13 Register Description

Registers can be 8, 16, or 32 bits wide. Atomic 8-, 16- and 32-bit accesses are supported. In addition, the 8-bit quarters and 16-bit halves of a 32-bit register, and the 8-bit halves of a 16-bit register can be accessed directly.

Some registers are optionally write-protected by the Peripheral Access Controller (PAC). Optional PAC write protection is denoted by the "PAC Write-Protection" property in each individual register description. For details, refer to [12.5.7 Register Access Protection](#).

### 12.13.1 Control

**Name:** CTRL  
**Offset:** 0x0000  
**Reset:** 0x00  
**Property:** PAC Write-Protection

	7	6	5	4	3	2	1	0
				CE	MBIST	CRC		SWRST
Access				W	W	W		W
Reset				0	0	0		0

**Bit 4 – CE** Chip-Erase

Writing a '0' to this bit has no effect.

Writing a '1' to this bit starts the Chip-Erase operation.

**Bit 3 – MBIST** Memory Built-In Self-Test

Writing a '0' to this bit has no effect.

Writing a '1' to this bit starts the memory BIST algorithm.

**Bit 2 – CRC** 32-bit Cyclic Redundancy Check

Writing a '0' to this bit has no effect.

Writing a '1' to this bit starts the cyclic redundancy check algorithm.

**Bit 0 – SWRST** Software Reset

Writing a '0' to this bit has no effect.

Writing a '1' to this bit resets the module.

### 12.13.2 Status A

**Name:** STATUSA  
**Offset:** 0x0001  
**Reset:** 0x00  
**Property:** PAC Write Protection

	7	6	5	4	3	2	1	0
Access				R/W	R/W	R/W	R/W	R/W
Reset				0	0	0	0	0

**Bit 4 – PERR** Protection Error

Writing a '0' to this bit has no effect.

Writing a '1' to this bit clears the Protection Error bit.

This bit is set when a command that is not allowed in Protected state is issued.

**Bit 3 – FAIL** Failure

Writing a '0' to this bit has no effect.

Writing a '1' to this bit clears the Failure bit.

This bit is set when a DSU operation failure is detected.

**Bit 2 – BERR** Bus Error

Writing a '0' to this bit has no effect.

Writing a '1' to this bit clears the Bus Error bit.

This bit is set when a bus error is detected.

**Bit 1 – CRSTEXT** CPU Reset Phase Extension

Writing a '0' to this bit has no effect.

Writing a '1' to this bit clears the CPU Reset Phase Extension bit.

This bit is set when a debug adapter Cold-Plugging is detected, which extends the CPU Reset phase.

**Bit 0 – DONE** Done

Writing a '0' to this bit has no effect.

Writing a '1' to this bit clears the Done bit.

This bit is set when a DSU operation is completed.



### 12.13.3 Status B

**Name:** STATUSB  
**Offset:** 0x0002  
**Reset:** 0x0x  
**Property:** PAC Write-Protection

	7	6	5	4	3	2	1	0
			CELCK	HPE	DCCD1	DCCD0	DBGPRES	PROT
Access			R	R	R	R	R	R
Reset			0	0	0	0	x	x

**Bit 5 – CELCK** Chip Erase Locked  
 Writing a '0' to this bit has no effect.  
 Writing a '1' to this bit has no effect.  
 This bit is set when Chip Erase is locked.  
 This bit is cleared when Chip Erase is unlocked.

**Bit 4 – HPE** Hot-Plugging Enable  
 Writing a '0' to this bit has no effect.  
 Writing a '1' to this bit has no effect.  
 This bit is set when Hot-Plugging is enabled.  
 This bit is cleared when Hot-Plugging is disabled. This is the case when the SWCLK function is changed.  
 Only a power-reset or a external reset can set it again.

**Bits 2, 3 – DCCD** Debug Communication Channel x Dirty  
 Writing a '0' to this bit has no effect.  
 Writing a '1' to this bit has no effect.  
 This bit is set when DCC is written.  
 This bit is cleared when DCC is read.

**Bit 1 – DBGPRES** Debugger Present  
 Writing a '0' to this bit has no effect.  
 Writing a '1' to this bit has no effect.  
 This bit is set when a debugger probe is detected.  
 This bit is never cleared.

**Bit 0 – PROT** Protected  
 Writing a '0' to this bit has no effect.  
 Writing a '1' to this bit has no effect.  
 This bit is set at power-up when the device is protected.  
 This bit is never cleared.

# SAM D5x/E5x Family Data Sheet

## DSU - Device Service Unit

### 12.13.4 Address

**Name:** ADDR  
**Offset:** 0x0004  
**Reset:** 0x00000000  
**Property:** PAC Write Protection

Bit	31	30	29	28	27	26	25	24
	ADDR[29:22]							
Access	R/W	R/W	R/W	R/W	R/W	R/W	R/W	R/W
Reset	0	0	0	0	0	0	0	0
Bit	23	22	21	20	19	18	17	16
	ADDR[21:14]							
Access	R/W	R/W	R/W	R/W	R/W	R/W	R/W	R/W
Reset	0	0	0	0	0	0	0	0
Bit	15	14	13	12	11	10	9	8
	ADDR[13:6]							
Access	R/W	R/W	R/W	R/W	R/W	R/W	R/W	R/W
Reset	0	0	0	0	0	0	0	0
Bit	7	6	5	4	3	2	1	0
	ADDR[5:0]						AMOD[1:0]	
Access	R/W	R/W	R/W	R/W	R/W	R/W	R/W	R/W
Reset	0	0	0	0	0	0	0	0

#### Bits 31:2 – ADDR[29:0] Address

Initial word start address needed for memory operations.

#### Bits 1:0 – AMOD[1:0] Access Mode

The functionality of these bits is dependent on the operation mode.

Bit description when operating CRC32: refer to [12.11.3 32-bit Cyclic Redundancy Check CRC32](#)

Bit description when testing onboard memories (MBIST): refer to [12.11.6 Testing of On-Board Memories MBIST](#)

# SAM D5x/E5x Family Data Sheet

## DSU - Device Service Unit

### 12.13.5 Length

**Name:** LENGTH  
**Offset:** 0x0008  
**Reset:** 0x00000000  
**Property:** PAC Write Protection

Bit	31	30	29	28	27	26	25	24
LENGTH[29:22]								
Access	R/W	R/W	R/W	R/W	R/W	R/W	R/W	R/W
Reset	0	0	0	0	0	0	0	0
Bit	23	22	21	20	19	18	17	16
LENGTH[21:14]								
Access	R/W	R/W	R/W	R/W	R/W	R/W	R/W	R/W
Reset	0	0	0	0	0	0	0	0
Bit	15	14	13	12	11	10	9	8
LENGTH[13:6]								
Access	R/W	R/W	R/W	R/W	R/W	R/W	R/W	R/W
Reset	0	0	0	0	0	0	0	0
Bit	7	6	5	4	3	2	1	0
LENGTH[5:0]								
Access	R/W	R/W	R/W	R/W	R/W	R/W		
Reset	0	0	0	0	0	0		

**Bits 31:2 – LENGTH[29:0]** Length  
 Length in words needed for memory operations.

# SAM D5x/E5x Family Data Sheet

## DSU - Device Service Unit

### 12.13.6 Data

**Name:** DATA  
**Offset:** 0x000C  
**Reset:** 0x00000000  
**Property:** PAC Write Protection

Bit	31	30	29	28	27	26	25	24
	DATA[31:24]							
Access	R/W	R/W	R/W	R/W	R/W	R/W	R/W	R/W
Reset	0	0	0	0	0	0	0	0
Bit	23	22	21	20	19	18	17	16
	DATA[23:16]							
Access	R/W	R/W	R/W	R/W	R/W	R/W	R/W	R/W
Reset	0	0	0	0	0	0	0	0
Bit	15	14	13	12	11	10	9	8
	DATA[15:8]							
Access	R/W	R/W	R/W	R/W	R/W	R/W	R/W	R/W
Reset	0	0	0	0	0	0	0	0
Bit	7	6	5	4	3	2	1	0
	DATA[7:0]							
Access	R/W	R/W	R/W	R/W	R/W	R/W	R/W	R/W
Reset	0	0	0	0	0	0	0	0

#### Bits 31:0 – DATA[31:0] Data

Memory operation initial value or result value.

# SAM D5x/E5x Family Data Sheet

## DSU - Device Service Unit

### 12.13.7 Debug Communication Channel x

**Name:** DCC  
**Offset:**  $0x10 + n \cdot 0x04$  [ $n=0..1$ ]  
**Reset:** 0x00000000  
**Property:** -

Bit	31	30	29	28	27	26	25	24
	DATA[31:24]							
Access	R/W	R/W	R/W	R/W	R/W	R/W	R/W	R/W
Reset	0	0	0	0	0	0	0	0
Bit	23	22	21	20	19	18	17	16
	DATA[23:16]							
Access	R/W	R/W	R/W	R/W	R/W	R/W	R/W	R/W
Reset	0	0	0	0	0	0	0	0
Bit	15	14	13	12	11	10	9	8
	DATA[15:8]							
Access	R/W	R/W	R/W	R/W	R/W	R/W	R/W	R/W
Reset	0	0	0	0	0	0	0	0
Bit	7	6	5	4	3	2	1	0
	DATA[7:0]							
Access	R/W	R/W	R/W	R/W	R/W	R/W	R/W	R/W
Reset	0	0	0	0	0	0	0	0

**Bits 31:0 – DATA[31:0]** Data  
 Data register.

# SAM D5x/E5x Family Data Sheet

## DSU - Device Service Unit

### 12.13.8 Device Identification

**Name:** DID  
**Offset:** 0x0018  
**Property:** PAC Write Protection

The information in this register is related to the *Ordering Information*.

	Bit	31	30	29	28	27	26	25	24
		PROCESSOR[3:0]				FAMILY[4:1]			
Access		R	R	R	R	R	R	R	R
Reset		p	p	p	p	f	f	f	f
	Bit	23	22	21	20	19	18	17	16
		FAMILY[0:0]		SERIES[5:0]					
Access		R		R	R	R	R	R	R
Reset		f		s	s	s	s	s	s
	Bit	15	14	13	12	11	10	9	8
		DIE[3:0]				REVISION[3:0]			
Access		R	R	R	R	R	R	R	R
Reset		d	d	d	d	r	r	r	r
	Bit	7	6	5	4	3	2	1	0
		DEVSEL[7:0]							
Access		R	R	R	R	R	R	R	R
Reset		x	x	x	x	x	x	x	x

**Bits 31:28 – PROCESSOR[3:0]** Processor

The value of this field defines the processor used on the device.

**Bits 27:23 – FAMILY[4:0]** Product Family

The value of this field corresponds to the product family part of the ordering code.

**Bits 21:16 – SERIES[5:0]** Product Series

The value of this field corresponds to the product series part of the ordering code.

**Bits 15:12 – DIE[3:0]** Die Number

Identifies the die family.

**Bits 11:8 – REVISION[3:0]** Revision Number

Identifies the die revision number. Refer the product family silicon errata and data sheet clarification document for further information.

**Note:** The device variant (last letter of the ordering number) is independent of the die revision (DSU.DID.REVISION): The device variant denotes functional differences, whereas the die revision marks evolution of the die.

**Bits 7:0 – DEVSEL[7:0]** Device Selection

This bit field identifies a device within a product family and product series.

**Related Links**

2. [Ordering Information](#)

### 12.13.9 Configuration

**Name:** CFG  
**Offset:** 0x1C  
**Reset:** 0x00000002  
**Property:** PAC Write-Protection

Bit	31	30	29	28	27	26	25	24
Access								
Reset								
Bit	23	22	21	20	19	18	17	16
Access								
Reset								
Bit	15	14	13	12	11	10	9	8
Access								
Reset								
Bit	7	6	5	4	3	2	1	0
Access				R/W	R/W	R/W	R/W	R/W
Reset				0	0	0	1	0

**Bit 4 – ETBRAMEN** Trace Control

ETB Ram Enable Writing a one to this bit will reserve the first 32KB of the RAM for the Trace ETB ram buffer. Refer to *Memories / SRAM Memory Configuration* section for details.

**Bits 3:2 – DCCDMALEVEL[1:0]** DMA Trigger Level

Value	Description
0x0	DMA Trigger rises when DCC is empty.
0x1	DMA Trigger rises when DCC is full.
0x2 – 0x3	Reserved

**Bits 1:0 – LQOS[1:0]** Latency Quality Of Service

These bits define the priority access during the memory access. Refer to *SRAM Quality of Service*.



### 12.13.10 Device Configuration

**Name:** DCFG  
**Offset:** 0xF0 + n\*0x04 [n=0..1]  
**Reset:** 0x00000000  
**Property:** PAC Write-Protection

	Bit	31	30	29	28	27	26	25	24
		DCFG[31:24]							
Access	Reset	0	0	0	0	0	0	0	0
	Bit	23	22	21	20	19	18	17	16
		DCFG[23:16]							
Access	Reset	0	0	0	0	0	0	0	0
	Bit	15	14	13	12	11	10	9	8
		DCFG[15:8]							
Access	Reset	0	0	0	0	0	0	0	0
	Bit	7	6	5	4	3	2	1	0
		DCFG[7:0]							
Access	Reset	0	0	0	0	0	0	0	0

**Bits 31:0 – DCFG[31:0] Device Configuration**

### 12.13.11 CoreSight ROM Table Entry x

**Name:** ENTRY  
**Offset:** 0x1000 + n\*0x04 [n=0..1]  
**Reset:** 0xxxxxx00x  
**Property:** PAC Write-Protection

	Bit	31	30	29	28	27	26	25	24	
		ADDOFF[19:12]								
Access		R	R	R	R	R	R	R	R	
Reset		x	x	x	x	x	x	x	x	
	Bit	23	22	21	20	19	18	17	16	
		ADDOFF[11:4]								
Access		R	R	R	R	R	R	R	R	
Reset		x	x	x	x	x	x	x	x	
	Bit	15	14	13	12	11	10	9	8	
		ADDOFF[3:0]								
Access		R	R	R	R					
Reset		x	x	x	x					
	Bit	7	6	5	4	3	2	1	0	
								FMT	EPRES	
Access								R	R	
Reset								1	x	

**Bits 31:12 – ADDOFF[19:0] Address Offset**

The base address of the component, relative to the base address of this ROM table.

**Bit 1 – FMT Format**

Always reads as '1', indicating a 32-bit ROM table.

**Bit 0 – EPRES Entry Present**

This bit indicates whether an entry is present at this location in the ROM table.

This bit is set at power-up if the device is not protected indicating that the entry is not present.

This bit is cleared at power-up if the device is not protected indicating that the entry is present.

# SAM D5x/E5x Family Data Sheet

## DSU - Device Service Unit

### 12.13.12 CoreSight ROM Table End

**Name:** END  
**Offset:** 0x1008  
**Reset:** 0x00000000  
**Property:** -

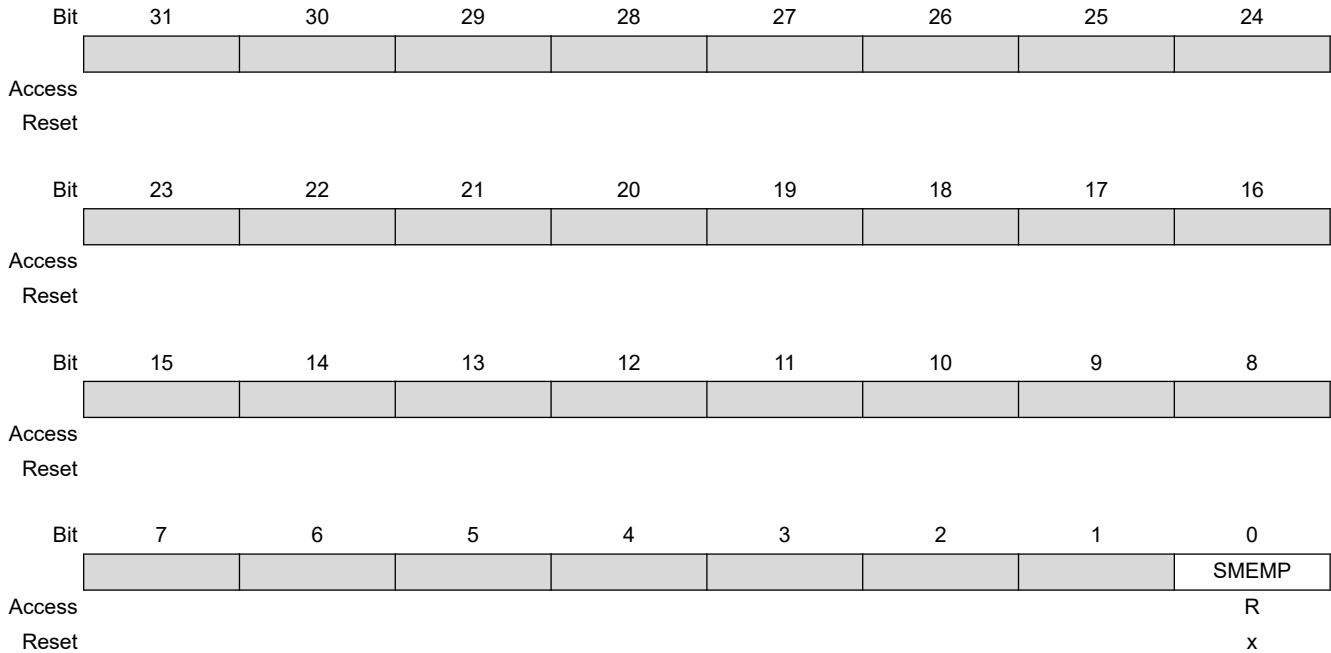
Bit	31	30	29	28	27	26	25	24
	END[31:24]							
Access	R	R	R	R	R	R	R	R
Reset	0	0	0	0	0	0	0	0
Bit	23	22	21	20	19	18	17	16
	END[23:16]							
Access	R	R	R	R	R	R	R	R
Reset	0	0	0	0	0	0	0	0
Bit	15	14	13	12	11	10	9	8
	END[15:8]							
Access	R	R	R	R	R	R	R	R
Reset	0	0	0	0	0	0	0	0
Bit	7	6	5	4	3	2	1	0
	END[7:0]							
Access	R	R	R	R	R	R	R	R
Reset	0	0	0	0	0	0	0	0

#### Bits 31:0 – END[31:0] End Marker

Indicates the end of the CoreSight ROM table entries.

### 12.13.13 CoreSight ROM Table Memory Type

**Name:** MEMTYPE  
**Offset:** 0x1FCC  
**Reset:** 0x0000000x  
**Property:** -



**Bit 0 – SMEMP** System Memory Present

This bit indicates whether system memory is present on the bus that connects to the ROM table. This bit is set at power-up if the device is not protected, indicating that the system memory is accessible from a debug adapter. This bit is cleared at power-up if the device is protected, indicating that the system memory is not accessible from a debug adapter.

### 12.13.14 Peripheral Identification 4

**Name:** PID4  
**Offset:** 0x1FD0  
**Reset:** 0x00000000  
**Property:** -

	Bit	31	30	29	28	27	26	25	24
Access									
Reset									
	Bit	23	22	21	20	19	18	17	16
Access									
Reset									
	Bit	15	14	13	12	11	10	9	8
Access									
Reset									
	Bit	7	6	5	4	3	2	1	0
		FKBC[3:0]				JEPCC[3:0]			
Access		R	R	R	R	R	R	R	R
Reset		0	0	0	0	0	0	0	0

**Bits 7:4 – FKBC[3:0]** 4KB Count

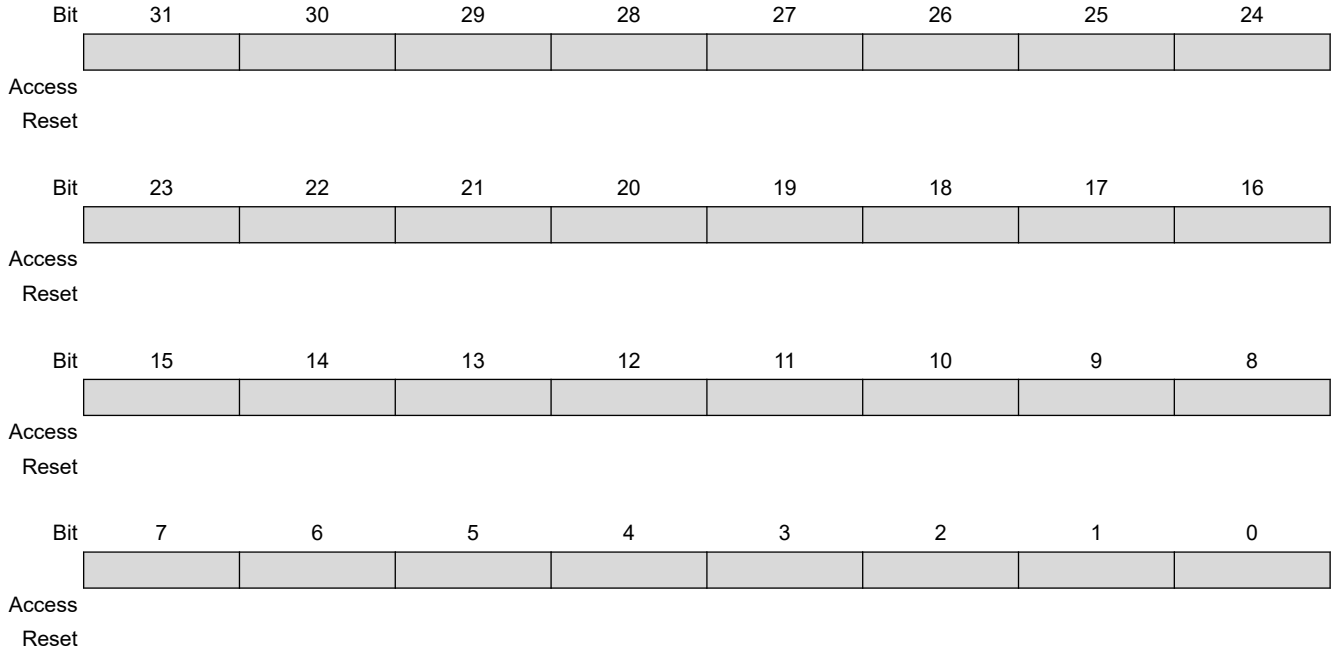
These bits will always return zero when read, indicating that this debug component occupies one 4KB block.

**Bits 3:0 – JEPCC[3:0]** JEP-106 Continuation Code

These bits will always return zero when read.

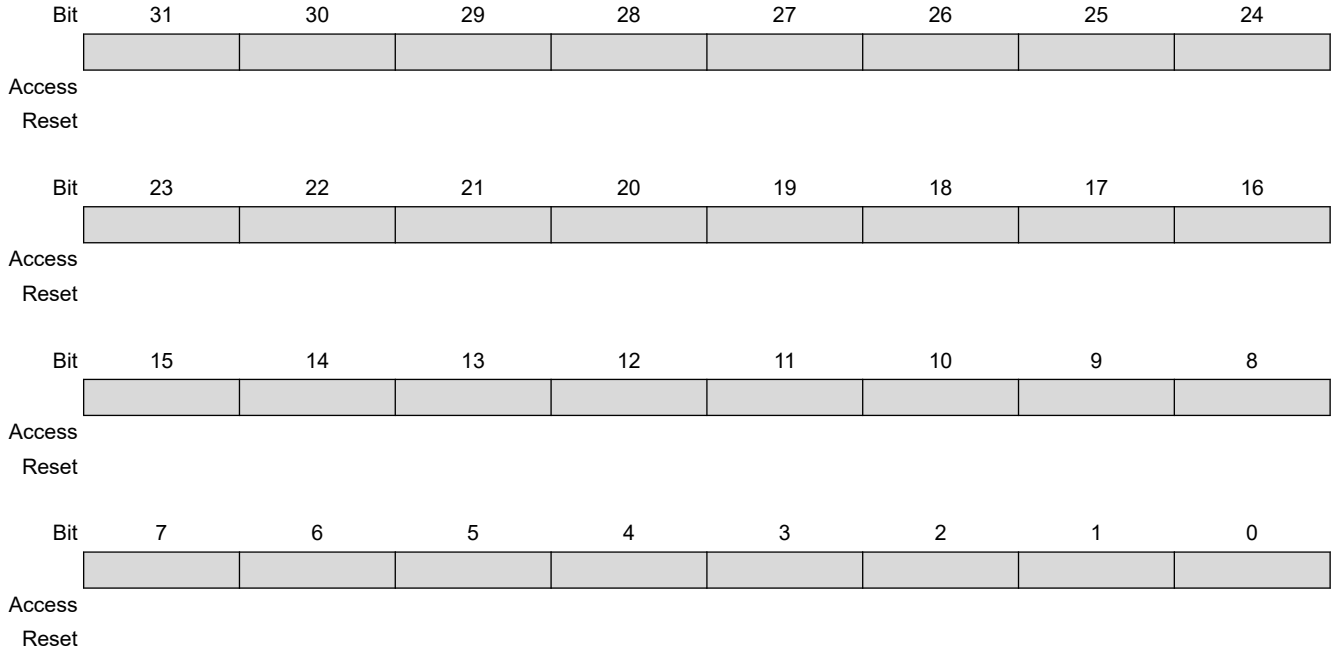
### 12.13.15 Peripheral Identification 7

**Name:** PID7  
**Offset:** 0x1FDC  
**Reset:** 0x00000000  
**Property:** Read-Only



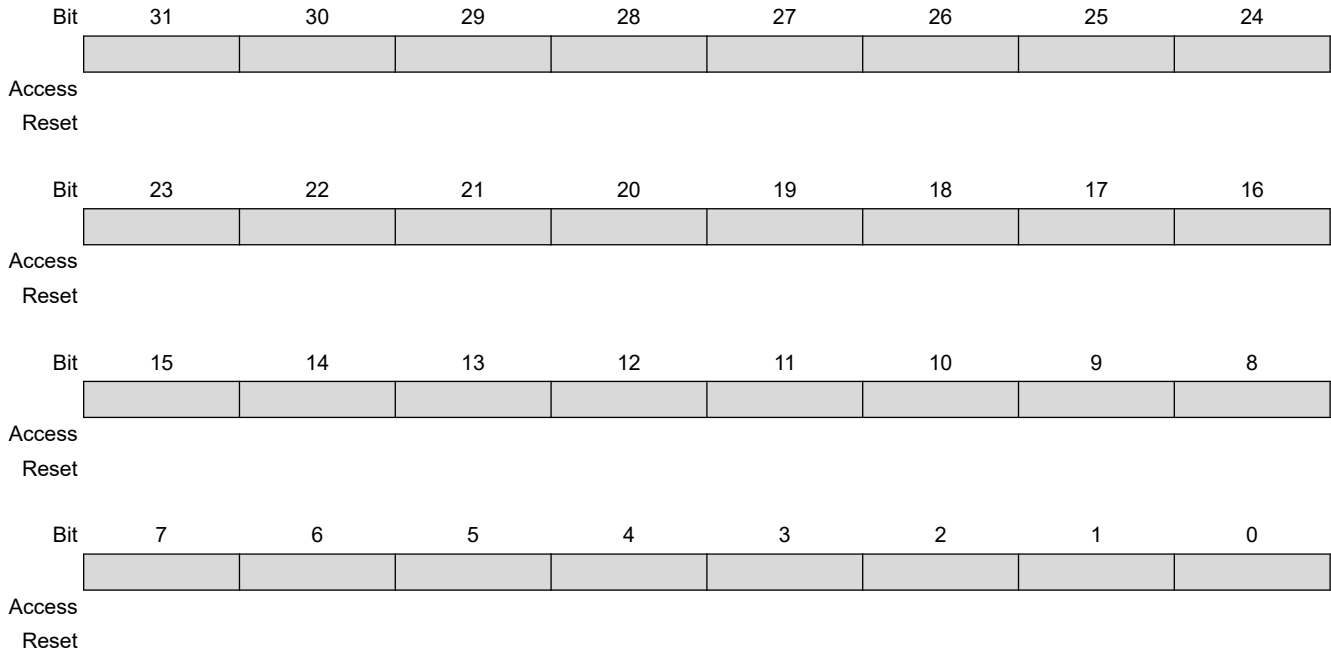
**12.13.16 Peripheral Identification 6**

**Name:** PID6  
**Offset:** 0x1FD8  
**Reset:** 0x00000000  
**Property:** Read-Only



### 12.13.17 Peripheral Identification 5

**Name:** PID5  
**Offset:** 0x1FD4  
**Reset:** 0x00000000  
**Property:** Read-Only





### 12.13.18 Peripheral Identification 0

**Name:** PID0  
**Offset:** 0x1FE0  
**Reset:** 0x00000000  
**Property:** -

Bit	31	30	29	28	27	26	25	24
Access								
Reset								
Bit	23	22	21	20	19	18	17	16
Access								
Reset								
Bit	15	14	13	12	11	10	9	8
Access								
Reset								
Bit	7	6	5	4	3	2	1	0
	PARTNBL[7:0]							
Access	R	R	R	R	R	R	R	R
Reset	0	0	0	0	0	0	0	0

**Bits 7:0 – PARTNBL[7:0] Part Number Low**

These bits will always return 0xD0 when read, indicating that this device implements a DSU module instance.

### 12.13.19 Peripheral Identification 1

**Name:** PID1  
**Offset:** 0x1FE4  
**Reset:** 0x000000FC  
**Property:** -

Bit	31	30	29	28	27	26	25	24
Access								
Reset								
Bit	23	22	21	20	19	18	17	16
Access								
Reset								
Bit	15	14	13	12	11	10	9	8
Access								
Reset								
Bit	7	6	5	4	3	2	1	0
	JEPIDCL[3:0]				PARTNBH[3:0]			
Access	R	R	R	R	R	R	R	R
Reset	1	1	1	1	1	1	0	0

**Bits 7:4 – JEPIDCL[3:0]** Low Part of the JEP-106 Identity Code  
 These bits will always return 0xF when read (JEP-106 identity code is 0x1F).

**Bits 3:0 – PARTNBH[3:0]** Part Number High  
 These bits will always return 0xC when read, indicating that this device implements a DSU module instance.

### 12.13.20 Peripheral Identification 2

**Name:** PID2  
**Offset:** 0x1FE8  
**Reset:** 0x00000009  
**Property:** -

Bit	31	30	29	28	27	26	25	24
Access								
Reset								
Bit	23	22	21	20	19	18	17	16
Access								
Reset								
Bit	15	14	13	12	11	10	9	8
Access								
Reset								
Bit	7	6	5	4	3	2	1	0
	REVISION[3:0]				JEPU		JEPIDCH[2:0]	
Access	R	R	R	R	R	R	R	R
Reset	0	0	0	0	1	0	0	1

**Bits 7:4 – REVISION[3:0]** Revision Number

Revision of the peripheral. Starts at 0x0 and increments by one at both major and minor revisions.

**Bit 3 – JEPU** JEP-106 Identity Code is Used

This bit will always return one when read, indicating that JEP-106 code is used.

**Bits 2:0 – JEPIDCH[2:0]** JEP-106 Identity Code High

These bits will always return 0x1 when read, (JEP-106 identity code is 0x1F).

### 12.13.21 Peripheral Identification 3

**Name:** PID3  
**Offset:** 0x1FEC  
**Reset:** 0x00000000  
**Property:** -

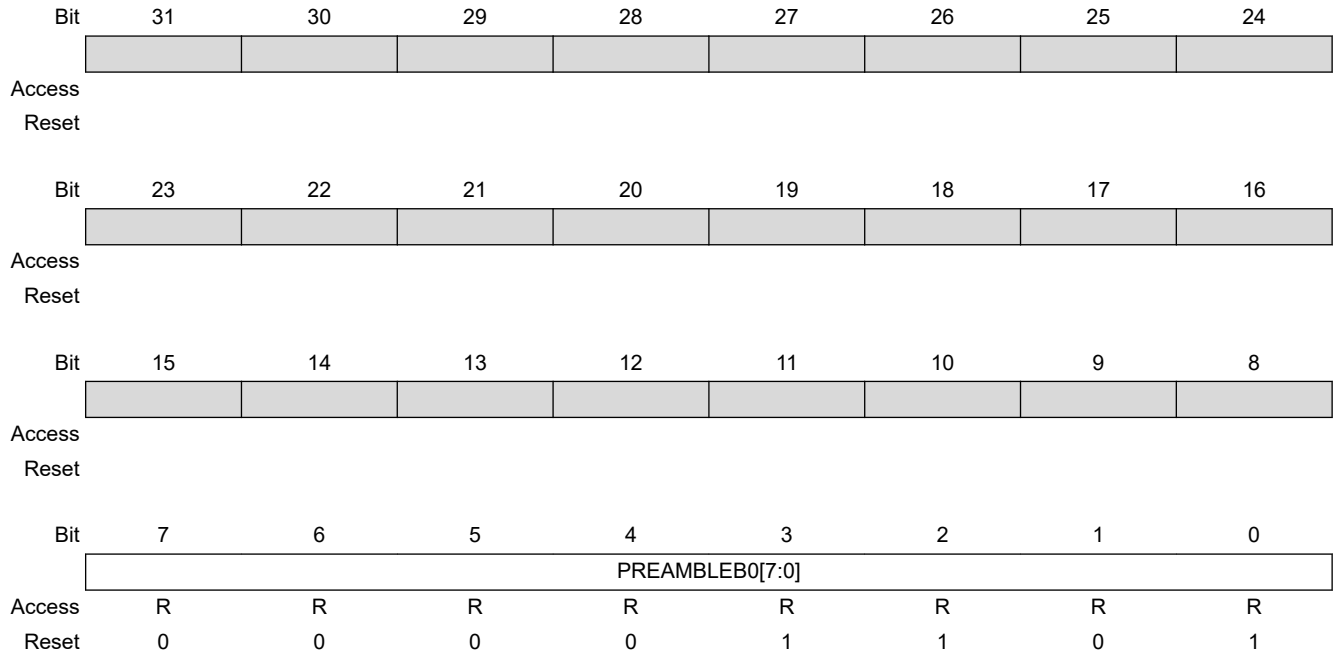
	Bit	31	30	29	28	27	26	25	24
Access									
Reset									
	Bit	23	22	21	20	19	18	17	16
Access									
Reset									
	Bit	15	14	13	12	11	10	9	8
Access									
Reset									
	Bit	7	6	5	4	3	2	1	0
		REVAND[3:0]				CUSMOD[3:0]			
Access		R	R	R	R	R	R	R	R
Reset		0	0	0	0	0	0	0	0

**Bits 7:4 – REVAND[3:0]** Revision Number  
 These bits will always return 0x0 when read.

**Bits 3:0 – CUSMOD[3:0]** ARM CUSMOD  
 These bits will always return 0x0 when read.

### 12.13.22 Component Identification 0

**Name:** CID0  
**Offset:** 0x1FF0  
**Reset:** 0x0000000D  
**Property:** -



**Bits 7:0 – PREAMBLE0[7:0]** Preamble Byte 0  
 These bits will always return 0x0000000D when read.

### 12.13.23 Component Identification 1

**Name:** CID1  
**Offset:** 0x1FF4  
**Reset:** 0x00000010  
**Property:** -

	Bit	31	30	29	28	27	26	25	24
Access									
Reset									
	Bit	23	22	21	20	19	18	17	16
Access									
Reset									
	Bit	15	14	13	12	11	10	9	8
Access									
Reset									
	Bit	7	6	5	4	3	2	1	0
		CCLASS[3:0]				PREAMBLE[3:0]			
Access		R	R	R	R	R	R	R	R
Reset		0	0	0	1	0	0	0	0

**Bits 7:4 – CCLASS[3:0]** Component Class

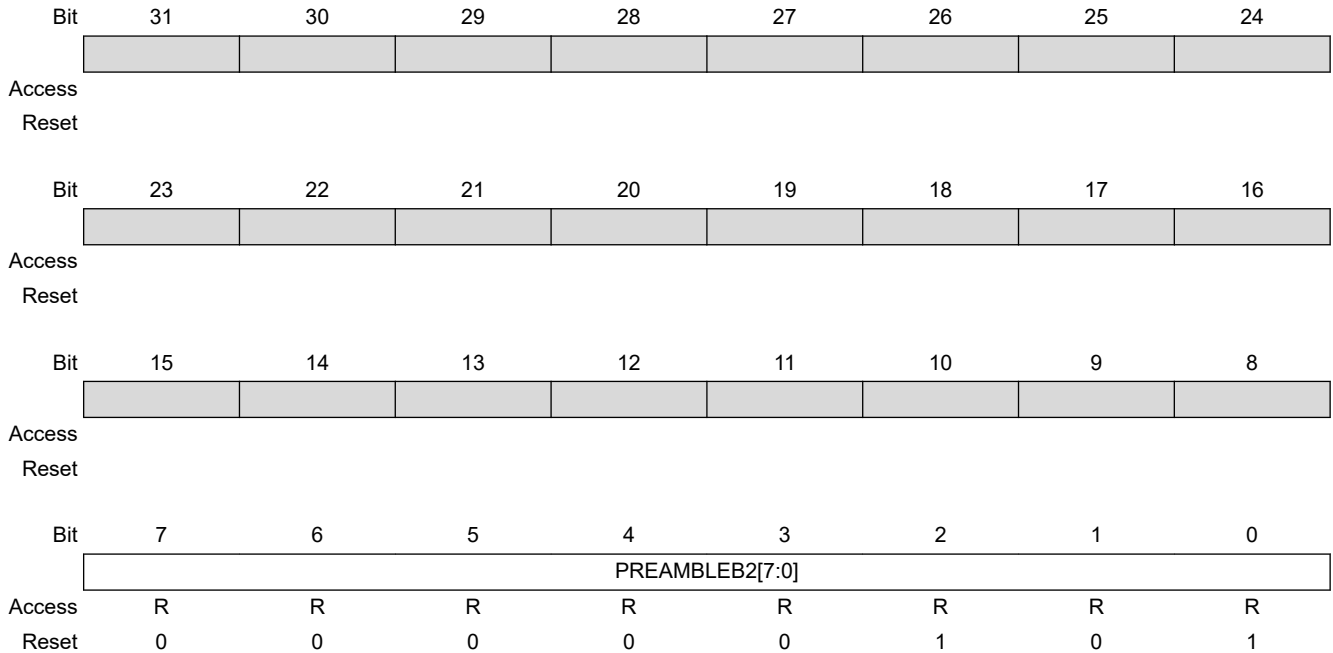
These bits will always return 0x1 when read indicating that this ARM CoreSight component is ROM table (refer to the ARM Debug Interface v5 Architecture Specification at <http://www.arm.com>).

**Bits 3:0 – PREAMBLE[3:0]** Preamble

These bits will always return 0x00 when read.

### 12.13.24 Component Identification 2

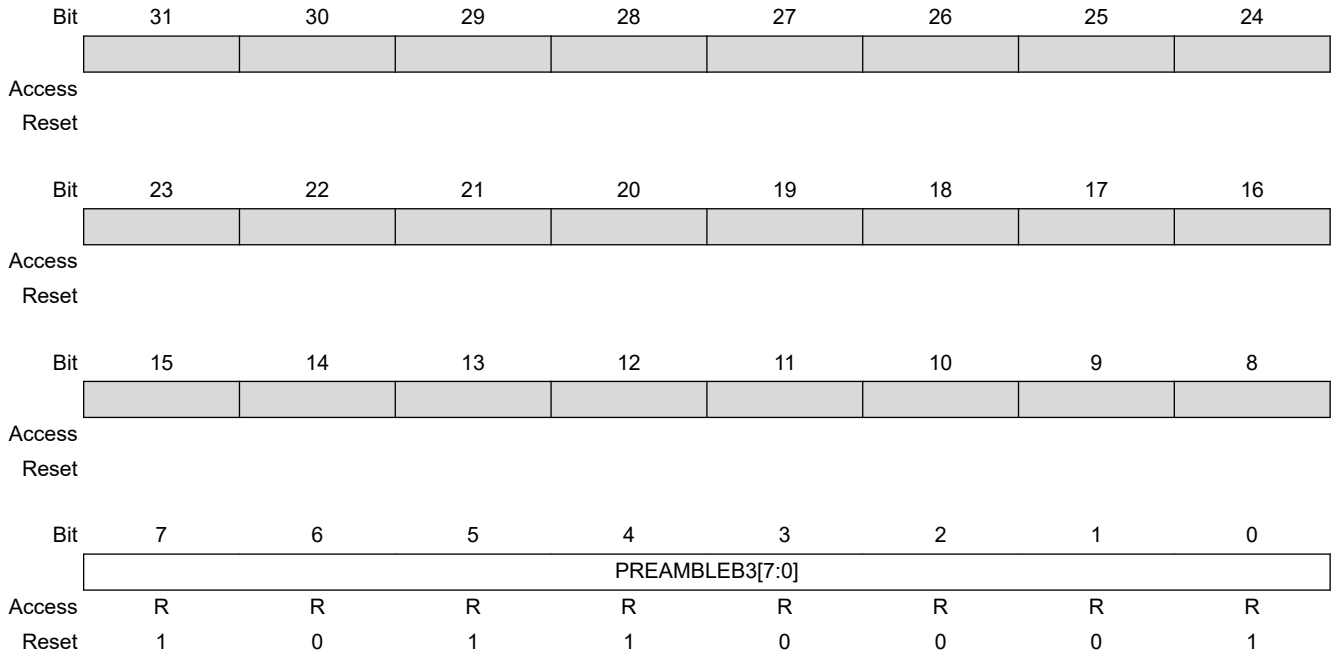
**Name:** CID2  
**Offset:** 0x1FF8  
**Reset:** 0x00000005  
**Property:** -



**Bits 7:0 – PREAMBLEB2[7:0]** Preamble Byte 2  
 These bits will always return 0x00000005 when read.

### 12.13.25 Component Identification 3

**Name:** CID3  
**Offset:** 0x1FFC  
**Reset:** 0x000000B1  
**Property:** -



**Bits 7:0 – PREAMBLEB3[7:0]** Preamble Byte 3  
 These bits will always return 0x000000B1 when read.



### 13. Clock System

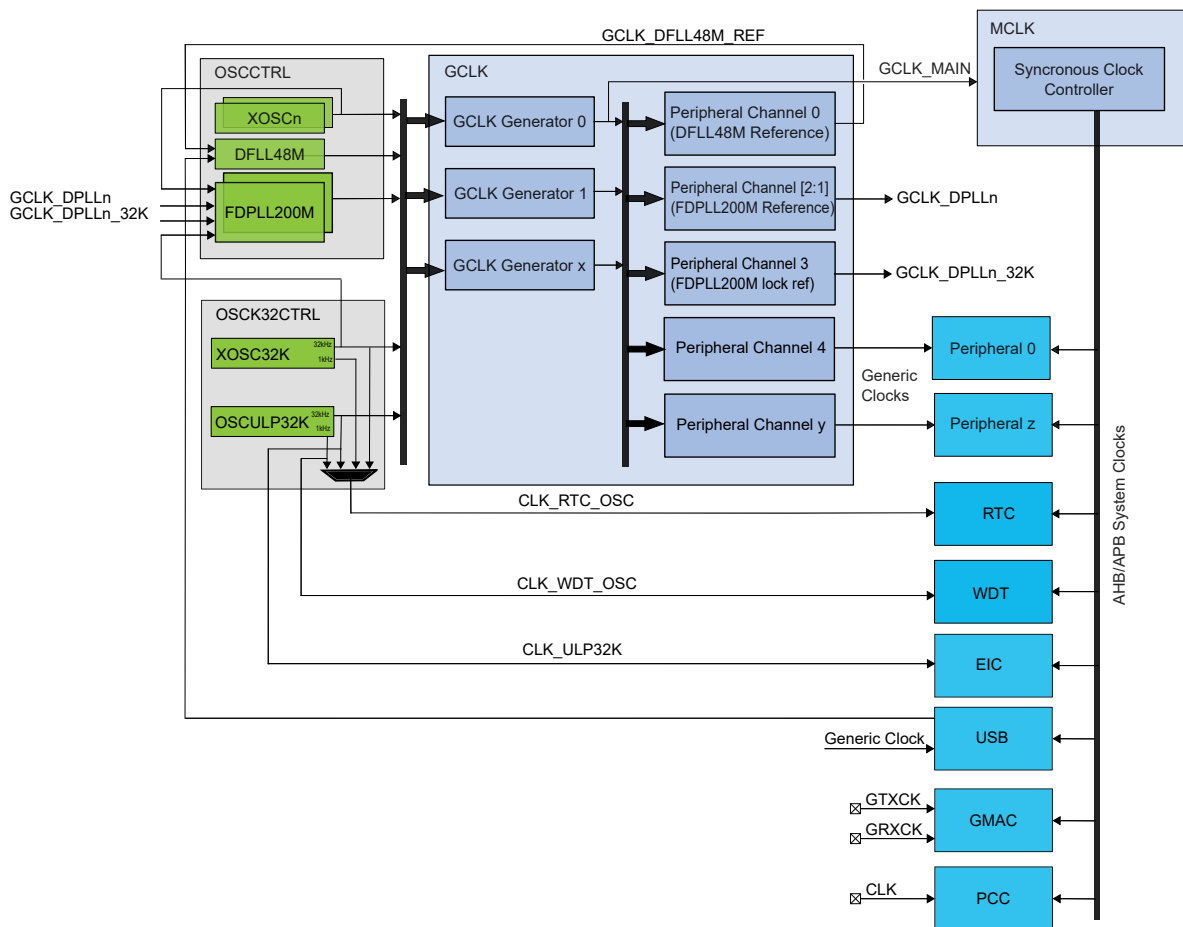
This chapter summarizes the clock distribution and terminology in the SAM D5x/E5x device. It does not explain every detail of its configuration. For in-depth documentation, see the respective peripherals descriptions and the *Generic Clock* documentation.

#### Related Links

- 14. [GCLK - Generic Clock Controller](#)
- 15. [MCLK – Main Clock](#)

### 13.1 Clock Distribution

Figure 13-1. Clock Distribution



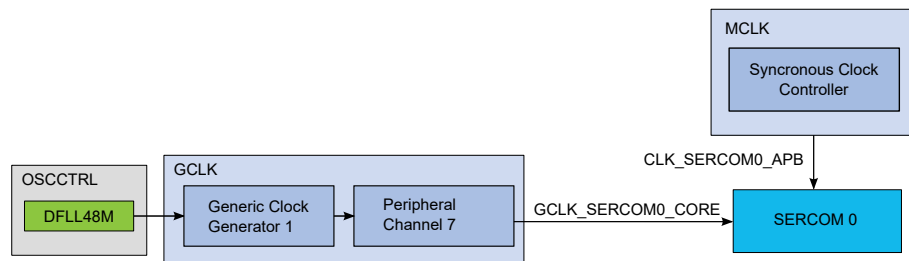
The SAM D5x/E5x clock system consists of:

- *Clock sources*, i.e. oscillators controlled by OSCCTRL and OSC32CTRL
  - A clock source provides a time base that is used by other components, such as Generic Clock Generators. Example clock sources are the external crystal oscillator (XOSC) and the Digital Frequency Locked Loop (DFLL48M).
- *Generic Clock Controller (GCLK)*, which generates, controls and distributes the asynchronous clock consisting of:

- *Generic Clock Generators:* These are programmable prescalers that can use any of the system clock sources as a time base. The Generic Clock Generator 0 generates the clock signal GCLK\_MAIN, which is used by the Power Manager and the Main Clock (MCLK) module, which in turn generates synchronous clocks.
- *Generic Clocks:* These are clock signals generated by Generic Clock Generators and output by the Peripheral Channels, and serve as clocks for the peripherals of the system. Multiple instances of a peripheral will typically have a separate Generic Clock for each instance. Generic Clock 0 serves as the clock source for the DFLL48M clock input (when multiplying another clock source).
- *Main Clock Controller (MCLK)*
  - The MCLK generates and controls the synchronous clocks on the system. This includes the CPU, bus clocks (APB, AHB) as well as the synchronous (to the CPU) user interfaces of the peripherals. It contains clock masks that can turn on/off the user interface of a peripheral as well as prescalers for the CPU and bus clocks.

The next figure shows an example where SERCOM0 is clocked by the DFLL48M in open loop mode. The DFLL48M is enabled, the Generic Clock Generator 1 uses the DFLL48M as its clock source and feeds into Peripheral Channel 7. The Generic Clock 7, also called GCLK\_SERCOM0\_CORE, is connected to SERCOM0. The SERCOM0 interface, clocked by CLK\_SERCOM0\_APB, has been unmasked in the APBC Mask register in the MCLK.

**Figure 13-2. Example of SERCOM Clock**



To customize the clock distribution, refer to these registers and bit fields:

- The source oscillator for a generic clock generator  $n$  is selected by writing to the Source bit field in the Generator Control  $n$  register (GCLK.GENCTRL $n$ .SRC).
- A Peripheral Channel  $m$  can be configured to use a specific Generic Clock Generator by writing to the Generic Clock Generator bit field in the respective Peripheral Channel  $m$  register (GCLK.PCHCTRL $m$ .GEN)
- The Peripheral Channel number,  $m$ , is fixed for a given peripheral. See the Mapping table in the description of GCLK.PCHCTRL $m$ .
- The AHB clocks are enabled and disabled by writing to the respective bit in the AHB Mask register (MCLK.AHBMASK).
- The APB clocks are enabled and disabled by writing to the respective bit in the APB  $x$  Mask registers (MCLK.APB $x$ MASK).

### Related Links

[13.7 Clocks after Reset](#)

### 13.2 Synchronous and Asynchronous Clocks

As the CPU and the peripherals can be in different clock domains, i.e. they are clocked from different clock sources and/or with different clock speeds, some peripheral accesses by the CPU need to be synchronized. In this case the peripheral includes a Synchronization Busy (SYNCBUSY) register that can be used to check if a sync operation is in progress.

For a general description, see [13.3 Register Synchronization](#). Some peripherals have specific properties described in their individual sub-chapter "Synchronization".

In the datasheet, references to Synchronous Clocks are referring to the CPU and bus clocks (MCLK), while asynchronous clocks are generated by the Generic Clock Controller (GCLK).

#### Related Links

[14.6.6 Synchronization](#)

### 13.3 Register Synchronization

#### 13.3.1 Overview

All peripherals are composed of one digital bus interface connected to the APB or AHB bus and running from a corresponding clock in the Main Clock domain, and one peripheral core running from the peripheral Generic Clock (GCLK).

Communication between these clock domains must be synchronized. This mechanism is implemented in hardware, so the synchronization process takes place even if the peripheral generic clock is running from the same clock source and on the same frequency as the bus interface.

All registers in the bus interface are accessible without synchronization.

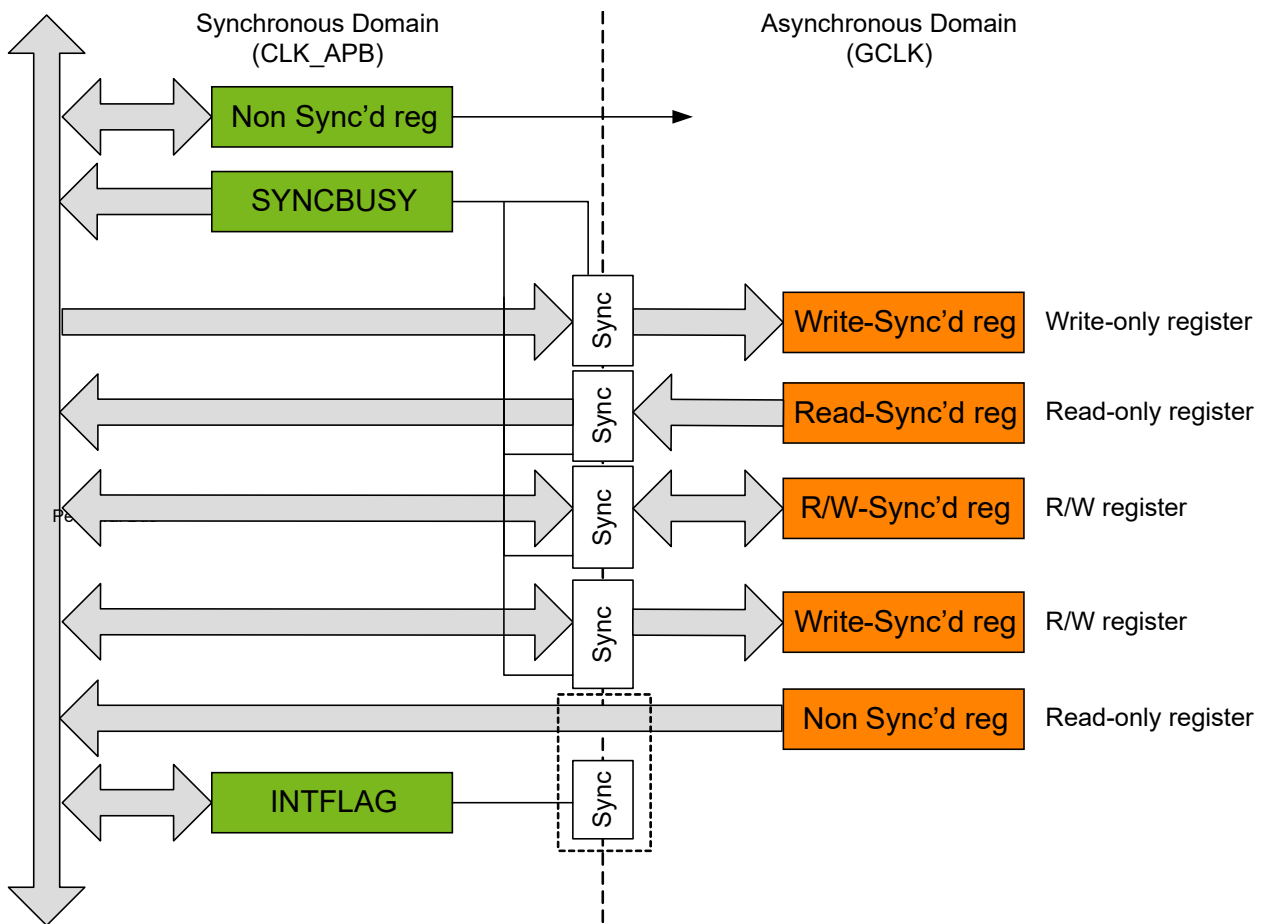
All registers in the peripheral core are synchronized when written. Some registers in the peripheral core are synchronized when read.

Each individual register description will have the properties "Read-Synchronized" and/or "Write-Synchronized" if a register is synchronized.

As shown in the figure below, each register that requires synchronization has its individual synchronizer and its individual synchronization status bit in the Synchronization Busy register (SYNCBUSY).

**Note:** For registers requiring both read- and write-synchronization, the corresponding bit in SYNCBUSY is shared.

**Figure 13-3. Register Synchronization Overview**



### 13.3.2 General Write Synchronization

Write-Synchronization is triggered by writing to a register in the peripheral clock domain (GCLK). The respective bit in the Synchronization Busy register (SYNCBUSY) will be set when the write-synchronization starts and cleared when the write-synchronization is complete. Refer also to [13.3.7 Synchronization Delay](#).

When write-synchronization is ongoing for a register, any subsequent write attempts to this register will be discarded, and an error will be reported through the Peripheral Access Controller (PAC).

**Example:**

REGA, REGB are 8-bit core registers. REGC is a 16-bit core register.

Offset	Register
0x00	REGA
0x01	REGB
0x02	REGC
0x03	

Synchronization is per register, so multiple registers can be synchronized in parallel. Consequently, after REGA (8-bit access) was written, REGB (8-bit access) can be written immediately without error.

---

---

REGC (16-bit access) can be written without affecting REGA or REGB. If REGC is written to in two consecutive 8-bit accesses without waiting for synchronization, the second write attempt will be discarded and an error is generated through the PAC.

A 32-bit access to offset 0x00 will write all three registers. Note that REGA, REGB and REGC can be updated at different times because of independent write synchronization.

### 13.3.3 General Read Synchronization

Read-synchronized registers are synchronized each time the register value is updated but the corresponding SYNCBUSY bits are not set. Reading a read-synchronized register does not start a new synchronization, it returns the last synchronized value.

**Note:** The corresponding bits in SYNCBUSY will automatically be set when the device wakes up from sleep because read-synchronized registers need to be synchronized. Therefore reading a read-synchronized register before its corresponding SYNCBUSY bit is cleared will return the last synchronized value before sleep mode.

However, if a register is also write-synchronized, any write access while the SYNCBUSY bit is set will be executed successfully. If concurrent read and write access is detected, the read is discarded and a new synchronization will start.

### 13.3.4 Completion of Synchronization

In order to check if synchronization is complete, the user can either poll the relevant bits in SYNCBUSY or use the Synchronisation Ready interrupt (if available). The Synchronization Ready interrupt flag will be set when all ongoing synchronizations are complete, i.e. when all bits in SYNCBUSY are '0'.

### 13.3.5 Write Synchronization for CTRLA.ENABLE

Setting the Enable bit in a module's Control A register (CTRLA.ENABLE) will trigger write-synchronization and set SYNCBUSY.ENABLE.

CTRLA.ENABLE will read its new value immediately after being written.

SYNCBUSY.ENABLE will be cleared by hardware when the operation is complete.

The Synchronization Ready interrupt (if available) cannot be used to enable write-synchronization.

### 13.3.6 Write-Synchronization for Software Reset Bit

Setting the Software Reset bit in CTRLA (CTRLA.SWRST=1) will trigger write-synchronization and set SYNCBUSY.SWRST. When writing a '1' to the CTRLA.SWRST bit it will immediately read as '1'.

CTRLA.SWRST and SYNCBUSY.SWRST will be cleared by hardware when the peripheral has been reset.

Writing a '0' to the CTRLA.SWRST bit has no effect.

The Ready interrupt (if available) cannot be used for Software Reset write-synchronization.

**Note:** Not all peripherals have the SWRST bit in the respective CTRLA register.

### 13.3.7 Synchronization Delay

The synchronization will delay write and read accesses by a certain amount. This delay  $D$  is within the range of:

$$5 \times P_{GCLK} + 2 \times P_{APB} < D < 6 \times P_{GCLK} + 3 \times P_{APB}$$

Where  $P_{GCLK}$  is the period of the generic clock and  $P_{APB}$  is the period of the peripheral bus clock. A normal peripheral bus register access duration is  $2 \times P_{APB}$ .

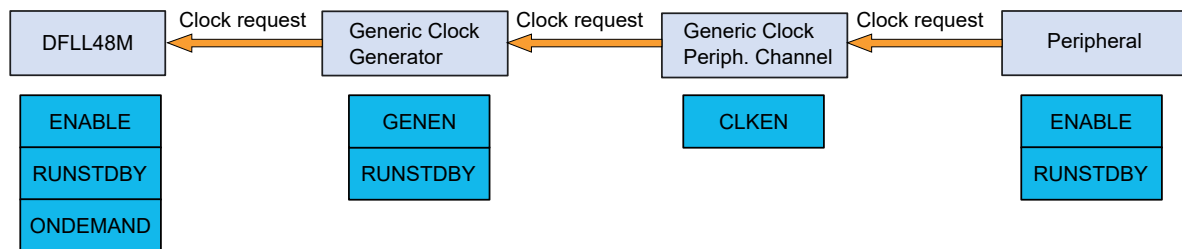
### 13.4 Enabling a Peripheral

In order to enable a peripheral that is clocked by a Generic Clock, the following parts of the system needs to be configured:

- A running Clock Source
- A clock from the Generic Clock Generator must be configured to use one of the running Clock Sources, and the Generator must be enabled.
- The Peripheral Channel that provides the Generic Clock signal to the peripheral must be configured to use a running Generic Clock Generator, and the Generic Clock must be enabled.
- The user interface of the peripheral needs to be unmasked in the PM. If this is not done the peripheral registers will read all 0's and any writing attempts to the peripheral will be discarded.

### 13.5 On Demand Clock Requests

**Figure 13-4. Clock Request Routing**



All clock sources in the system can be run in an on-demand mode: the clock source is in a stopped state unless a peripheral is requesting the clock source. Clock requests propagate from the peripheral, via the GCLK, to the clock source. If one or more peripheral is using a clock source, the clock source will be started/kept running. As soon as the clock source is no longer needed and no peripheral has an active request, the clock source will be stopped until requested again.

The clock request can reach the clock source only if the peripheral, the generic clock and the clock from the Generic Clock Generator in-between are enabled. The time taken from a clock request being asserted to the clock source being ready is dependent on the clock source startup time, clock source frequency as well as the divider used in the Generic Clock Generator. The total startup time  $T_{start}$  from a clock request until the clock is available for the peripheral is between:

$$T_{start\_max} = \text{Clock source startup time} + 2 \times \text{clock source periods} + 2 \times \text{divided clock source periods}$$

$$T_{start\_min} = \text{Clock source startup time} + 1 \times \text{clock source period} + 1 \times \text{divided clock source period}$$

The time between the last active clock request stopped and the clock is shut down,  $T_{stop}$ , is between:

$$T_{stop\_min} = 1 \times \text{divided clock source period} + 1 \times \text{clock source period}$$

$$T_{stop\_max} = 2 \times \text{divided clock source periods} + 2 \times \text{clock source periods}$$

The On-Demand function can be disabled individually for each clock source by clearing the ONDEMAND bit located in each clock source controller. Consequently, the clock will always run whatever the clock request status is. This has the effect of removing the clock source startup time at the cost of power consumption.

The clock request mechanism can be configured to work in standby mode by setting the RUNSDTBY bits of the modules, see [Figure 13-4](#).

### 13.6 Power Consumption vs. Speed

When targeting for either a low-power or a fast acting system, some considerations have to be taken into account due to the nature of the asynchronous clocking of the peripherals:

If clocking a peripheral with a very low clock, the active power consumption of the peripheral will be lower. At the same time the synchronization to the synchronous (CPU) clock domain is dependent on the peripheral clock speed, and will take longer with a slower peripheral clock. This will cause worse response times and longer synchronization delays.

### 13.7 Clocks after Reset

On any Reset the synchronous clocks start to their initial state:

- DFLL48M is enabled and configured to run at 48MHz
- Generic Generator 0 uses DFLL48M as source and generates GCLK\_MAIN
- CPU and BUS clocks are undivided

On a Power-on Reset, the 32KHz clock sources are reset and the GCLK module starts to its initial state:

- All Generic Clock Generators are disabled except
  - Generator 0 is using DFLL48M at 48MHz as source and generates GCLK\_MAIN
- All Peripheral Channels in GCLK are disabled.

On a User Reset the GCLK module starts to its initial state, except for:

- Generic Clocks that are write-locked, i.e., the according WRTLOCK is set to 1 prior to Reset

#### Related Links

[16. RSTC – Reset Controller](#)

## 14. GCLK - Generic Clock Controller

### 14.1 Overview

Depending on the application, peripherals may require specific clock frequencies to operate correctly. The Generic Clock controller (GCLK) features 12 Generic Clock Generators [11:0] that can provide a wide range of clock frequencies.

Generators can be set to use different external and internal oscillators as source. The clock of each Generator can be divided. The outputs from the Generators are used as sources for the Peripheral Channels, which provide the Generic Clock (GCLK\_PERIPH) to the peripheral modules, as shown in [Figure 14-2](#). The number of Peripheral Clocks depends on how many peripherals the device has.

**Note:** The Generator 0 is always the direct source of the GCLK\_MAIN signal.

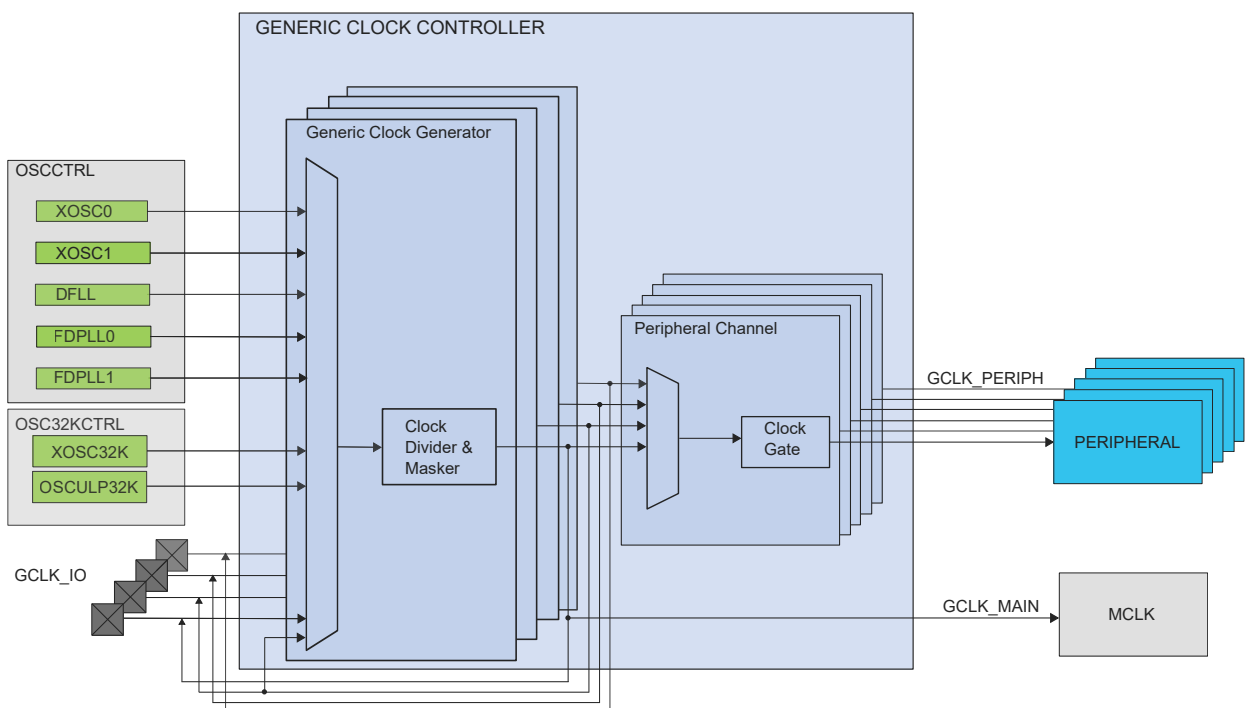
### 14.2 Features

- Provides a device-defined, configurable number of Peripheral Channel clocks
- Wide frequency range:
  - Various clock sources
  - Embedded dividers

### 14.3 Block Diagram

The generation of Peripheral Clock signals (GCLK\_PERIPH) and the Main Clock (GCLK\_MAIN) can be seen in [Device Clocking Diagram](#).

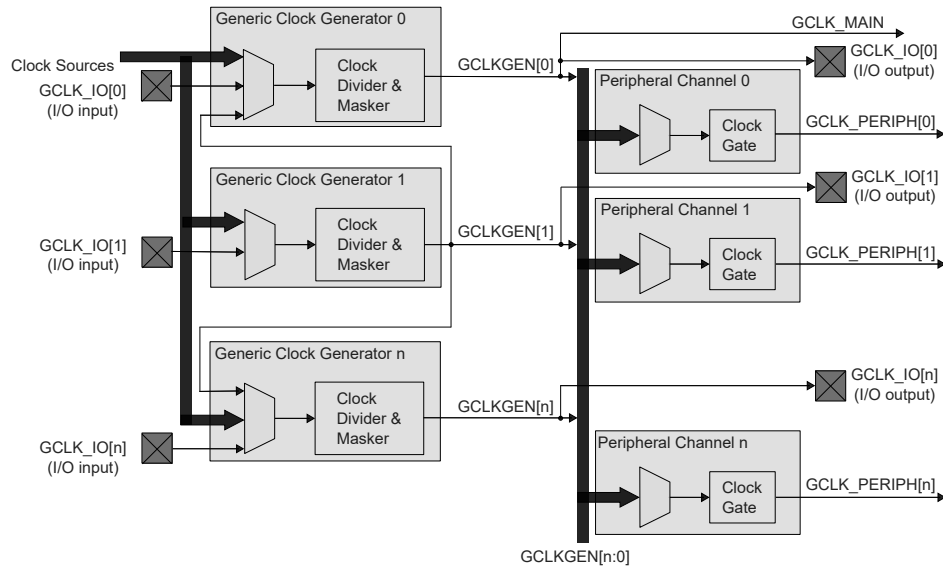
**Figure 14-1. Device Clocking Diagram**





The GCLK block diagram is shown below:

**Figure 14-2. Generic Clock Controller Block Diagram**



## 14.4 Signal Description

**Table 14-1. GCLK Signal Description**

Signal Name	Type	Description
GCLK_IO[7:0]	Digital I/O	Clock source for Generators when input Generic Clock signal when output

**Note:** One signal can be mapped on several pins.

### Related Links

[6. I/O Multiplexing and Considerations](#)

## 14.5 Product Dependencies

In order to use this peripheral, other parts of the system must be configured correctly, as described below.

### 14.5.1 I/O Lines

Using the GCLK I/O lines requires the I/O pins to be configured.

### Related Links

[32. PORT - I/O Pin Controller](#)

### 14.5.2 Power Management

The GCLK can operate in sleep modes, if required. Refer to the Sleep mode description in the Power Manager (PM) section.

### Related Links

[18. PM – Power Manager](#)

### 14.5.3 Clocks

The GCLK bus clock (CLK\_GCLK\_APB) can be enabled and disabled in the Main Clock Controller.

#### Related Links

[15.6.2.6 Peripheral Clock Masking](#)

[29. OSC32KCTRL – 32KHz Oscillators Controller](#)

### 14.5.4 DMA

Not applicable.

### 14.5.5 Interrupts

Not applicable.

### 14.5.6 Events

Not applicable.

### 14.5.7 Debug Operation

When the CPU is halted in debug mode the GCLK continues normal operation. If the GCLK is configured in a way that requires it to be periodically serviced by the CPU through interrupts or similar, improper operation or data loss may result during debugging.

### 14.5.8 Register Access Protection

All registers with write access can be optionally write-protected by the Peripheral Access Controller (PAC).

**Note:** Optional write protection is indicated by the "PAC Write Protection" property in the register description.

Write protection does not apply for accesses through an external debugger.

#### Related Links

[27. PAC - Peripheral Access Controller](#)

### 14.5.9 Analog Connections

Not applicable.

## 14.6 Functional Description

### 14.6.1 Principle of Operation

The GCLK module is comprised of twelve Generic Clock Generators (Generators) sourcing up to 64 Peripheral Channels and the Main Clock signal CLK\_MAIN.

A clock source selected as input to a Generator can either be used directly, or it can be prescaled in the Generator. A generator output is used by one or more Peripheral Channels to provide a peripheral generic clock signal (GCLK\_PERIPH) to the peripherals.

### 14.6.2 Basic Operation

#### 14.6.2.1 Initialization

Before a Generator is enabled, the corresponding clock source should be enabled. The Peripheral clock must be configured as outlined by the following steps:

1. The Generator must be enabled (GENCTRLn.GENEN=1) and the division factor must be set (GENTRLn.DIVSEL and GENCTRLn.DIV) by performing a single 32-bit write to the Generator Control register (GENCTRLn).
2. The Generic Clock for a peripheral must be configured by writing to the respective Peripheral Channel Control register (PCHCTRLm). The Generator used as the source for the Peripheral Clock must be written to the GEN bit field in the Peripheral Channel Control register (PCHCTRLm.GEN).

**Note:** Each Generator n is configured by one dedicated register GENCTRLn.

**Note:** Each Peripheral Channel m is configured by one dedicated register PCHCTRLm.

### 14.6.2.2 Enabling, Disabling, and Resetting

The GCLK module has no enable/disable bit to enable or disable the whole module.

The GCLK is reset by setting the Software Reset bit in the Control A register (CTRLA.SWRST) to 1. All registers in the GCLK will be reset to their initial state, except for Peripheral Channels and associated Generators that have their Write Lock bit set to 1 (PCHCTRLm.WRTLOCK). For further details, refer to [14.6.3.4 Configuration Lock](#).

### 14.6.2.3 Generic Clock Generator

Each Generator (GCLK\_GEN) can be set to run from one of eight different clock sources except GCLK\_GEN[1], which can be set to run from one of seven sources. GCLK\_GEN[1] is the only Generator that can be selected as source to others Generators.

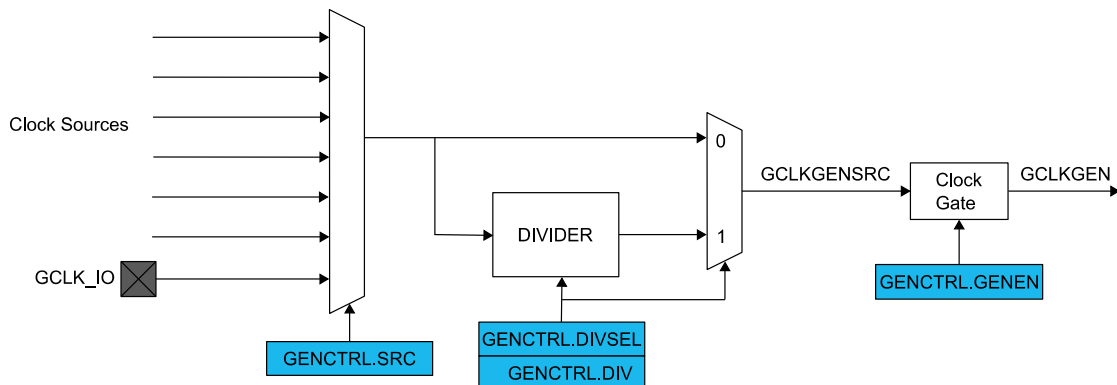
Each generator GCLK\_GEN[x] can be connected to one specific pin GCLK\_IO[x]. A pin GCLK\_IO[x] can be set either to act as source to GCLK\_GEN[x] or to output the clock signal generated by GCLK\_GEN[x].

The selected source can be divided. Each Generator can be enabled or disabled independently.

Each GCLK\_GEN clock signal can then be used as clock source for Peripheral Channels. Each Generator output is allocated to one or several Peripherals.

GCLK\_GEN[0] is used as GCLK\_MAIN for the synchronous clock controller inside the Main Clock Controller. Refer to the Main Clock Controller description for details on the synchronous clock generation.

**Figure 14-3. Generic Clock Generator**



### Related Links

[15. MCLK – Main Clock](#)

### 14.6.2.4 Enabling a Generator

A Generator is enabled by writing a '1' to the Generator Enable bit in the Generator Control register (GENCTRLn.GENEN=1).

### 14.6.2.5 Disabling a Generator

A Generator is disabled by writing a '0' to GENCTRLn.GENEN. When GENCTRLn.GENEN=0, the GCLK\_GEN[n] clock is disabled and gated.

### 14.6.2.6 Selecting a Clock Source for the Generator

Each Generator can individually select a clock source by setting the Source Select bit group in the Generator Control register (GENCTRLn.SRC).

Changing from one clock source, for example A, to another clock source, B, can be done on the fly: If clock source B is not ready, the Generator will continue using clock source A. As soon as source B is ready, the Generator will switch to it. During the switching operation, the Generator maintains clock requests to both clock sources A and B, and will release source A as soon as the switch is done. The according bit in SYNCBUSY register (SYNCBUSY.GENCTRLn) will remain '1' until the switch operation is completed.

The available clock sources are device dependent (usually the oscillators, RC oscillators, DPPLL). Only Generator 1 can be used as a common source for all other generators.

### 14.6.2.7 Changing the Clock Frequency

The selected source for a Generator can be divided by writing a division value in the Division Factor bit field of the Generator Control register (GENCTRLn.DIV). How the actual division factor is calculated is depending on the Divide Selection bit (GENCTRLn.DIVSEL).

If GENCTRLn.DIVSEL=0 and GENCTRLn.DIV is either 0 or 1, the output clock will be undivided.

**Note:** The number of available DIV bits may vary from Generator to Generator.

### 14.6.2.8 Duty Cycle

When dividing a clock with an odd division factor, the duty-cycle will not be 50/50. Setting the Improve Duty Cycle bit of the Generator Control register (GENCTRLn.IDC) will result in a 50/50 duty cycle.

### 14.6.2.9 External Clock

The output clock (GCLK\_GEN) of each Generator can be sent to I/O pins (GCLK\_IO).

If the Output Enable bit in the Generator Control register is set (GENCTRLn.OE = 1) and the generator is enabled (GENCTRLn.GENEN=1), the Generator requests its clock source and the GCLK\_GEN clock is output to an I/O pin.

**Note:** The I/O pin (GCLK\_IO[n]) must first be configured as output by writing the corresponding PORT registers.

If GENCTRLn.OE is 0, the according I/O pin is set to an Output Off Value, which is selected by GENCTRLn.OOV: If GENCTRLn.OOV is '0', the output clock will be low. If this bit is '1', the output clock will be high.

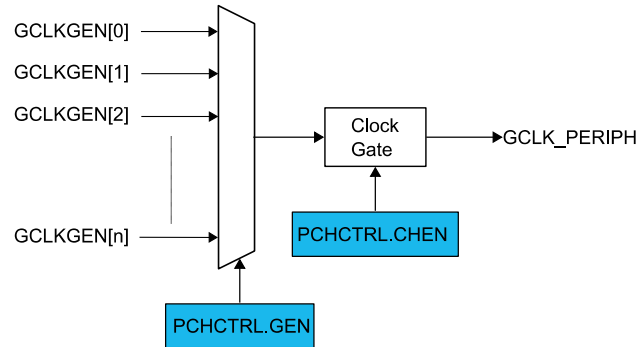
In Standby mode, if the clock is output (GENCTRLn.OE=1), the clock on the I/O pin is frozen to the OOV value if the Run In Standby bit of the Generic Control register (GENCTRLn.RUNSTDBY) is zero. If GENCTRLn.RUNSTDBY is '1', the GCLKGEN clock is kept running and output to the I/O pin.

#### Related Links

[18.6.3.5 Power Domain Controller](#)

### 14.6.3 Peripheral Clock

Figure 14-4. Peripheral Clock



#### 14.6.3.1 Enabling a Peripheral Clock

Before a Peripheral Clock is enabled, one of the Generators must be enabled (`GENCTRLn.GENEN`) and selected as source for the Peripheral Channel by setting the Generator Selection bits in the Peripheral Channel Control register (`PCHCTRLm.GEN`). Any available Generator can be selected as clock source for each Peripheral Channel.

When a Generator has been selected, the peripheral clock is enabled by setting the Channel Enable bit in the Peripheral Channel Control register, `PCHCTRLm.CHEN = 1`. The `PCHCTRLm.CHEN` bit must be synchronized to the generic clock domain. `PCHCTRLm.CHEN` will continue to read as its previous state until the synchronization is complete.

#### 14.6.3.2 Disabling a Peripheral Clock

A Peripheral Clock is disabled by writing `PCHCTRLm.CHEN=0`. The `PCHCTRLm.CHEN` bit must be synchronized to the Generic Clock domain. `PCHCTRLm.CHEN` will stay in its previous state until the synchronization is complete. The Peripheral Clock is gated when disabled.

#### Related Links

[14.8.4 PCHCTRLm](#)

#### 14.6.3.3 Selecting the Clock Source for a Peripheral

When changing a peripheral clock source by writing to `PCHCTRLm.GEN`, the peripheral clock must be disabled before re-enabling it with the new clock source setting. This prevents glitches during the transition:

1. Disable the Peripheral Channel by writing `PCHCTRLm.CHEN=0`
2. Assert that `PCHCTRLm.CHEN` reads '0'
3. Change the source of the Peripheral Channel by writing `PCHCTRLm.GEN`
4. Re-enable the Peripheral Channel by writing `PCHCTRLm.CHEN=1`

#### Related Links

[14.8.4 PCHCTRLm](#)

#### 14.6.3.4 Configuration Lock

The peripheral clock configuration can be locked for further write accesses by setting the Write Lock bit in the Peripheral Channel Control register (`PCHCTRLm.WRTLOCK=1`). All writing to the `PCHCTRLm` register will be ignored. It can only be unlocked by a Power Reset.

The Generator source of a locked Peripheral Channel will be locked, too: The corresponding `GENCTRLn` register is locked, and can be unlocked only by a Power Reset.

There is one exception concerning the Generator 0. As it is used as GCLK\_MAIN, it cannot be locked. It is reset by any Reset and will start up in a known configuration. The software reset (CTRLA.SWRST) can not unlock the registers.

In case of an external Reset, the Generator source will be disabled. Even if the WRTLOCK bit is written to '1' the peripheral channels are disabled (PCHCTRLm.CHEN set to '0') until the Generator source is enabled again. Then, the PCHCTRLm.CHEN are set to '1' again.

### Related Links

[14.8.1 CTRLA](#)

## 14.6.4 Additional Features

### 14.6.4.1 Peripheral Clock Enable after Reset

The Generic Clock Controller must be able to provide a generic clock to some specific peripherals after a Reset. That means that the configuration of the Generators and Peripheral Channels after Reset is device-dependent.

Refer to GENCTRLn.SRC for details on GENCTRLn reset.

Refer to PCHCTRLm.SRC for details on PCHCTRLm reset.

## 14.6.5 Sleep Mode Operation

### 14.6.5.1 SleepWalking

The GCLK module supports the SleepWalking feature.

If the system is in a sleep mode where the Generic Clocks are stopped, a peripheral that needs its clock in order to execute a process must request it from the Generic Clock Controller.

The Generic Clock Controller receives this request, determines which Generic Clock Generator is involved and which clock source needs to be awakened. It then wakes up the respective clock source, enables the Generator and Peripheral Channel stages successively, and delivers the clock to the peripheral.

The RUNSTDBY bit in the Generator Control register controls clock output to pin during standby sleep mode. If the bit is cleared, the Generator output is not available on pin. When set, the GCLK can continuously output the generator output to GCLK\_IO. Refer to [14.6.2.9 External Clock](#) for details.

### Related Links

[18. PM – Power Manager](#)

### 14.6.5.2 Minimize Power Consumption in Standby

The following table identifies when a Clock Generator is off in Standby Mode, minimizing the power consumption:

**Table 14-2. Clock Generator n Activity in Standby Mode**

Request for Clock n present	GENCTRLn.RUNSTDBY	GENCTRLn.OE	Clock Generator n
yes	-	-	active
no	1	1	active
no	1	0	OFF
no	0	1	OFF
no	0	0	OFF

### 14.6.5.3 Entering Standby Mode

There may occur a delay when the device is put into Standby, until the power is turned off. This delay is caused by running Clock Generators: if the Run in Standby bit in the Generator Control register (GENCTRLn.RUNSTDBY) is '0', GCLK must verify that the clock is turned off properly. The duration of this verification is frequency-dependent.

#### Related Links

[18. PM – Power Manager](#)

### 14.6.6 Synchronization

Due to asynchronicity between the main clock domain and the peripheral clock domains, some registers need to be synchronized when written or read.

An exception is the Channel Enable bit in the Peripheral Channel Control registers (PCHCTRLm.CHEN). When changing this bit, the bit value must be read-back to ensure the synchronization is complete and to assert glitch free internal operation. Note that changing the bit value under ongoing synchronization will *not* generate an error.

The following registers are synchronized when written:

- Generic Clock Generator Control register (GENCTRLn)
- Control A register (CTRLA)

Required write synchronization is denoted by the "Write-Synchronized" property in the register description.

#### Related Links

[14.8.1 CTRLA](#)

[14.8.4 PCHCTRLm](#)

# SAM D5x/E5x Family Data Sheet

## GCLK - Generic Clock Controller

### 14.7 Register Summary

Offset	Name	Bit Pos.									
0x00	<a href="#">CTRLA</a>	7:0								SWRST	
0x01 ... 0x03	Reserved										
0x04	<a href="#">SYNCBUSY</a>	7:0	GENCTRL[5:0]								SWRST
		15:8	GENCTRL[11:6]								
		23:16									
		31:24									
0x08 ... 0x1F	Reserved										
0x20	<a href="#">GENCTRL0</a>	7:0	SRC[4:0]								
		15:8		RUNSTDBY	DIVSEL	OE	OOV	IDC	GENEN		
		23:16	DIV[7:0]								
		31:24	DIV[15:8]								
...											
0x4C	<a href="#">GENCTRL11</a>	7:0	SRC[4:0]								
		15:8		RUNSTDBY	DIVSEL	OE	OOV	IDC	GENEN		
		23:16	DIV[7:0]								
		31:24	DIV[15:8]								
0x50 ... 0x7F	Reserved										
0x80	<a href="#">PCHCTRL0</a>	7:0	WRTLOCK	CHEN			GEN[3:0]				
		15:8									
		23:16									
		31:24									
...											
0x013C	<a href="#">PCHCTRL47</a>	7:0	WRTLOCK	CHEN			GEN[3:0]				
		15:8									
		23:16									
		31:24									

### 14.8 Register Description

Registers can be 8, 16, or 32 bits wide. Atomic 8-, 16- and 32-bit accesses are supported. In addition, the 8-bit quarters and 16-bit halves of a 32-bit register, and the 8-bit halves of a 16-bit register can be accessed directly.

Some registers are optionally write-protected by the Peripheral Access Controller (PAC). Optional PAC write protection is denoted by the "PAC Write-Protection" property in each individual register description. For details, refer to [14.5.8 Register Access Protection](#).



# SAM D5x/E5x Family Data Sheet

## GCLK - Generic Clock Controller

---

---

Some registers are synchronized when read and/or written. Synchronization is denoted by the "Write-Synchronized" or the "Read-Synchronized" property in each individual register description. For details, refer to [14.6.6 Synchronization](#).

### 14.8.1 Control A

**Name:** CTRLA  
**Offset:** 0x00  
**Reset:** 0x00  
**Property:** PAC Write-Protection, Write-Synchronized

	7	6	5	4	3	2	1	0
								SWRST
Access								R/W
Reset								0

**Bit 0 – SWRST** Software Reset

Writing a zero to this bit has no effect.

Setting this bit to 1 will reset all registers in the GCLK to their initial state after a Power Reset, except for generic clocks and associated Generators that have their WRTLOCK bit in PCHCTRLm set to 1.

Refer to GENCTRL Reset Value for details on GENCTRL register reset.

Refer to PCHCTRL Reset Value for details on PCHCTRL register reset.

Due to synchronization, there is a waiting period between setting CTRLA.SWRST and a completed Reset. CTRLA.SWRST and SYNCBUSY.SWRST will both be cleared when the reset is complete.

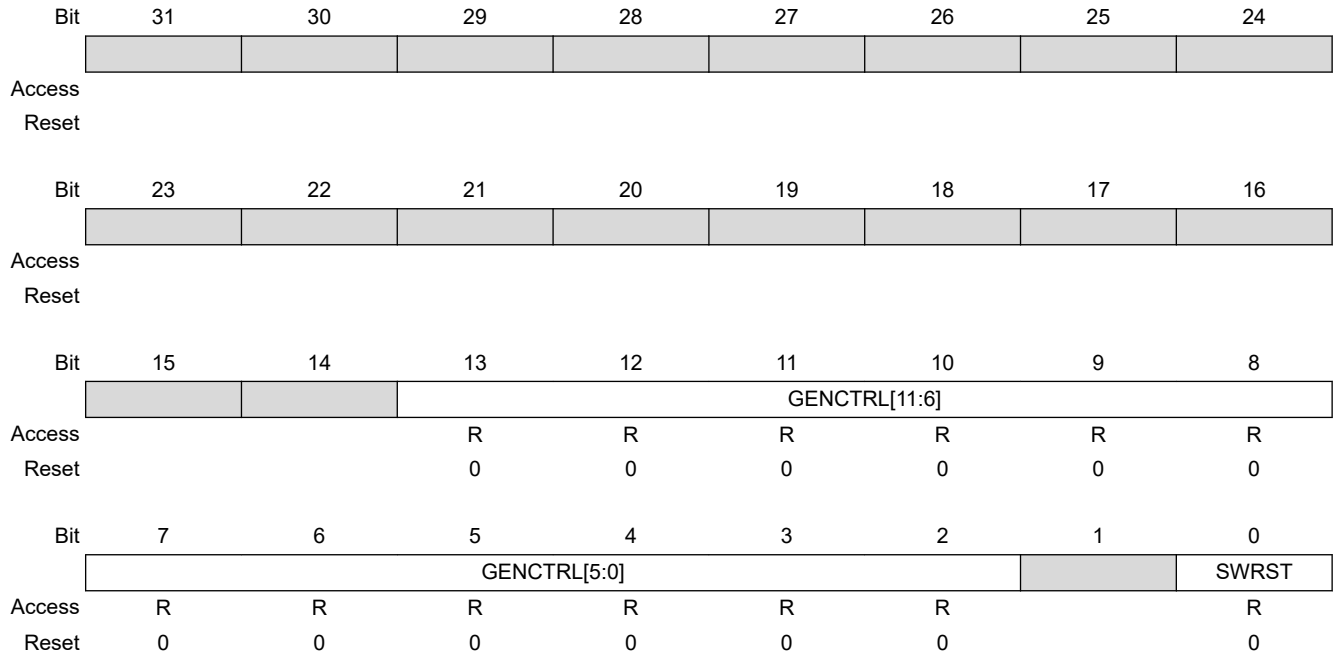
Value	Description
0	There is no Reset operation ongoing.
1	A Reset operation is ongoing.

# SAM D5x/E5x Family Data Sheet

## GCLK - Generic Clock Controller

### 14.8.2 Synchronization Busy

**Name:** SYNCBUSY  
**Offset:** 0x04  
**Reset:** 0x00000000  
**Property:** –



**Bits 13:2 – GENCTRL[11:0]** Generator Control n Synchronization Busy

This bit is cleared when the synchronization of the Generator Control n register (GENCTRLn) between clock domains is complete, or when clock switching operation is complete.

This bit is set when the synchronization of the Generator Control n register (GENCTRLn) between clock domains is started.

**Bit 0 – SWRST** Software Reset Synchronization Busy

This bit is cleared when the synchronization of the CTRLA.SWRST register bit between clock domains is complete.

This bit is set when the synchronization of the CTRLA.SWRST register bit between clock domains is started.

# SAM D5x/E5x Family Data Sheet

## GCLK - Generic Clock Controller

### 14.8.3 Generator Control

**Name:** GENCTRLn  
**Offset:** 0x20 + n\*0x04 [n=0..11]  
**Reset:** 0x00000106  
**Property:** PAC Write-Protection, Write-Synchronized

GENCTRLn controls the settings of Generic Generator n (n=[11:0]). The reset value is 0x00000106 for Generator n=0, else 0x00000000

Bit	31	30	29	28	27	26	25	24
	DIV[15:8]							
Access	R/W	R/W	R/W	R/W	R/W	R/W	R/W	R/W
Reset	0	0	0	0	0	0	0	0
Bit	23	22	21	20	19	18	17	16
	DIV[7:0]							
Access	R/W	R/W	R/W	R/W	R/W	R/W	R/W	R/W
Reset	0	0	0	0	0	0	0	0
Bit	15	14	13	12	11	10	9	8
			RUNSTDBY	DIVSEL	OE	OOV	IDC	GENEN
Access								
Reset			0	0	0	0	0	1
Bit	7	6	5	4	3	2	1	0
				SRC[4:0]				
Access				R/W	R/W	R/W	R/W	R/W
Reset				0	0	0	0	0

#### Bits 31:16 – DIV[15:0] Division Factor

These bits represent a division value for the corresponding Generator. The actual division factor is dependent on the state of DIVSEL. The number of relevant DIV bits for each Generator can be seen in this table. Written bits outside of the specified range will be ignored.

**Table 14-3. Division Factor Bits**

Generic Clock Generator	Division Factor Bits	Maximum Division Factor
Generator 0	8 division factor bits - DIV[7:0]	512
Generator 1	16 division factor bits - DIV[15:0]	131072
Generator 2 - 11	8 division factor bits - DIV[7:0]	512

#### Bit 13 – RUNSTDBY Run in Standby

This bit is used to keep the Generator running in Standby as long as it is configured to output to a dedicated GCLK\_IO pin. If GENCTRLn.OE is zero, this bit has no effect and the generator will only be running if a peripheral requires the clock.

Value	Description
0	The Generator is stopped in Standby and the GCLK_IO pin state (one or zero) will be dependent on the setting in GENCTRL.OOV.

# SAM D5x/E5x Family Data Sheet

## GCLK - Generic Clock Controller

Value	Description
1	The Generator is kept running and output to its dedicated GCLK_IO pin during Standby mode.

### Bit 12 – DIVSEL Divide Selection

This bit determines how the division factor of the clock source of the Generator will be calculated from DIV. If the clock source should not be divided, DIVSEL must be 0 and the GENCTRLn.DIV value must be either 0 or 1.

Value	Description
0	The Generator clock frequency equals the clock source frequency divided by GENCTRLn.DIV.
1	The Generator clock frequency equals the clock source frequency divided by $2^{(N+1)}$ , where N is the Division Factor Bits for the selected generator (refer to GENCTRLn.DIV).

### Bit 11 – OE Output Enable

This bit is used to output the Generator clock output to the corresponding pin (GCLK\_IO), as long as GCLK\_IO is not defined as the Generator source in the GENCTRLn.SRC bit field.

Value	Description
0	No Generator clock signal on pin GCLK_IO.
1	The Generator clock signal is output on the corresponding GCLK_IO, unless GCLK_IO is selected as a generator source in the GENCTRLn.SRC bit field.

### Bit 10 – OOV Output Off Value

This bit is used to control the clock output value on pin (GCLK\_IO) when the Generator is turned off or the OE bit is zero, as long as GCLK\_IO is not defined as the Generator source in the GENCTRLn.SRC bit field.

Value	Description
0	The GCLK_IO will be LOW when generator is turned off or when the OE bit is zero.
1	The GCLK_IO will be HIGH when generator is turned off or when the OE bit is zero.

### Bit 9 – IDC Improve Duty Cycle

This bit is used to improve the duty cycle of the Generator output to 50/50 for odd division factors.

Value	Description
0	Generator output clock duty cycle is not balanced to 50/50 for odd division factors.
1	Generator output clock duty cycle is 50/50.

### Bit 8 – GENEN Generator Enable

This bit is used to enable and disable the Generator.

Value	Description
0	Generator is disabled.
1	Generator is enabled.

### Bits 4:0 – SRC[4:0] Generator Clock Source Selection

These bits select the Generator clock source, as shown in this table.

**Table 14-4. Generator Clock Source Selection**

Value	Name	Description
0x00	XOSC0	XOSC 0 oscillator output

# SAM D5x/E5x Family Data Sheet

## GCLK - Generic Clock Controller

.....continued

Value	Name	Description
0x01	XOSC1	XOSC 1 oscillator output
0x02	GCLK_IN	Generator input pad (GCLK_IO)
0x03	GCLK_GEN1	Generic clock generator 1 output
0x04	OSCULP32K	OSCULP32K oscillator output
0x05	XOSC32K	XOSC32K oscillator output
0x06	DFLL	DFLL oscillator output
0x07	DPLL0	DPLL0 output
0x08	DPLL1	DPLL1 output
0x09-0x1F	Reserved	Reserved for future use

A Power Reset will reset all GENCTRLn registers. the Reset values of the GENCTRLn registers are shown in table below.

**Table 14-5. GENCTRLn Reset Value after a Power Reset**

GCLK Generator	Reset Value after a Power Reset
0	0x00000106
others	0x00000000

A User Reset will reset the associated GENCTRL register unless the Generator is the source of a locked Peripheral Channel (PCHCTRLm.WRTLOCK=1). The reset values of the GENCTRL register are as shown in the table below.

**Table 14-6. GENCTRLn Reset Value after a User Reset**

GCLK Generator	Reset Value after a User Reset
0	0x00000106
others	No change if the generator is used by a Peripheral Channel m with PCHCTRLm.WRTLOCK=1 else 0x00000000

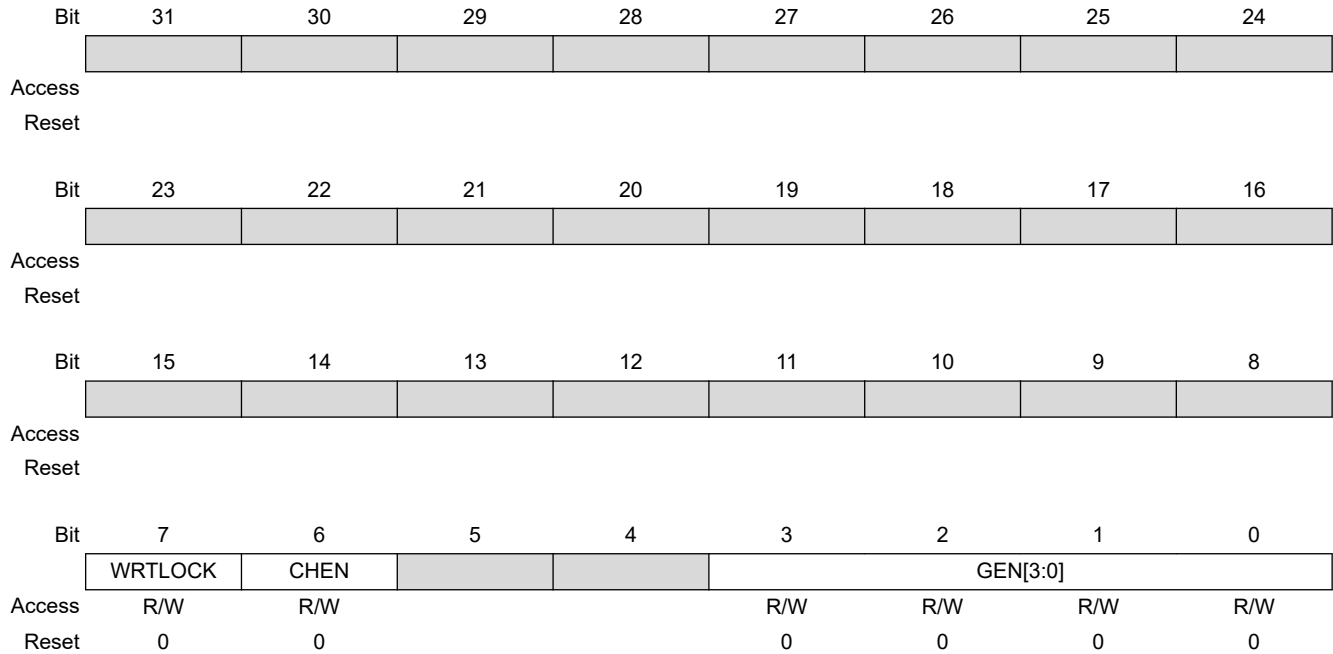
### Related Links

[14.8.4 PCHCTRLm](#)

### 14.8.4 Peripheral Channel Control

**Name:** PCHCTRLm  
**Offset:** 0x80 + m\*0x04 [m=0..47]  
**Reset:** 0x00000000  
**Property:** PAC Write-Protection

PCHCTRLm controls the settings of Peripheral Channel number m (m=[47:0]).



#### Bit 7 – WRTLOCK Write Lock

After this bit is set to '1', further writes to the PCHCTRLm register will be discarded. The control register of the corresponding Generator n (GENCTRLn), as assigned in PCHCTRLm.GEN, will also be locked. It can only be unlocked by a Power Reset.

Note that Generator 0 cannot be locked.

Value	Description
0	The Peripheral Channel register and the associated Generator register are not locked
1	The Peripheral Channel register and the associated Generator register are locked

#### Bit 6 – CHEN Channel Enable

This bit is used to enable and disable a Peripheral Channel.

Value	Description
0	The Peripheral Channel is disabled
1	The Peripheral Channel is enabled

#### Bits 3:0 – GEN[3:0] Generator Selection

This bit field selects the Generator to be used as the source of a peripheral clock, as shown in the table below:

# SAM D5x/E5x Family Data Sheet

## GCLK - Generic Clock Controller

**Table 14-7. Generator Selection**

Value	Description
0x0	Generic Clock Generator 0
0x1	Generic Clock Generator 1
0x2	Generic Clock Generator 2
0x3	Generic Clock Generator 3
0x4	Generic Clock Generator 4
0x5	Generic Clock Generator 5
0x6	Generic Clock Generator 6
0x7	Generic Clock Generator 7
0x8	Generic Clock Generator 8
0x9	Generic Clock Generator 9
0xA	Generic Clock Generator 10
0xB	Generic Clock Generator 11

**Table 14-8. Reset Value after a User Reset or a Power Reset**

Reset	PCHCTRLm.GEN	PCHCTRLm.CHEN	PCHCTRLm.WRTLOCK
Power Reset	0x0	0x0	0x0
User Reset	If WRTLOCK = 0 : 0x0  If WRTLOCK = 1: no change	If WRTLOCK = 0 : 0x0  If WRTLOCK = 1: no change	No change

A Power Reset will reset all the PCHCTRLm registers.

A User Reset will reset a PCHCTRL if WRTLOCK=0, or else, the content of that PCHCTRL remains unchanged.

The PCHCTRL register Reset values are shown in the table below, PCHCTRLm Mapping.

**Table 14-9. PCHCTRLm Mapping**

index(m)	Name	Description
0	GCLK_OSCCTRL_DFLL48	DFLL48 input clock source
1	GCLK_OSCCTRL_FDPLL0	Reference clock for FDPLL0
2	GCLK_OSCCTRL_FDPLL1	Reference clock for FDPLL1
3	GCLK_OSCCTRL_FDPLL0_32K GCLK_OSCCTRL_FDPLL1_32K GCLK_SDHC0_SLOW GCLK_SDHC1_SLOW GCLK_SERCOM[0..7]_SLOW	FDPLL0 32KHz clock for internal lock timer FDPLL1 32KHz clock for internal lock timer SDHC0 Slow SDHC1 Slow SERCOM[0..7] Slow
4	GCLK_EIC	EIC



# SAM D5x/E5x Family Data Sheet

## GCLK - Generic Clock Controller

.....continued

index(m)	Name	Description
5	GCLK_FREQM_MSR	FREQM Measure
6	GCLK_FREQM_REF	FREQM Reference
7	GCLK_SERCOM0_CORE	SERCOM0 Core
8	GCLK_SERCOM1_CORE	SERCOM1 Core
9	GCLK_TC0, GCLK_TC1	TC0, TC1
10	GCLK_USB	USB
22:11	GCLK_EVSYS[0..11]	EVSYS[0..11]
23	GCLK_SERCOM2_CORE	SERCOM2 Core
24	GCLK_SERCOM3_CORE	SERCOM3 Core
25	GCLK_TCC0, GCLK_TCC1	TCC0, TCC1
26	GCLK_TC2, GCLK_TC3	TC2, TC3
27	GCLK_CAN0	CAN0
28	GCLK_CAN1	CAN1
29	GCLK_TCC2, GCLK_TCC3	TCC2, TCC3
30	GCLK_TC4, GCLK_TC5	TC4, TC5
31	GCLK_PDEC	PDEC
32	GCLK_AC	AC
33	GCLK_CCL	CCL
34	GCLK_SERCOM4_CORE	SERCOM4 Core
35	GCLK_SERCOM5_CORE	SERCOM5 Core
36	GCLK_SERCOM6_CORE	SERCOM6 Core
37	GCLK_SERCOM7_CORE	SERCOM7 Core
38	GCLK_TCC4	TCC4
39	GCLK_TC6, GCLK_TC7	TC6, TC7
40	GCLK_ADC0	ADC0
41	GCLK_ADC1	ADC1
42	GCLK_DAC	DAC
44:43	GCLK_I2S	I2S
45	GCLK_SDHC0	SDHC0
46	GCLK_SDHC1	SDHC1
47	GCLK_CM4_TRACE	CM4 Trace

## 15. MCLK – Main Clock

### 15.1 Overview

The Main Clock (MCLK) controls the synchronous clock generation of the device.

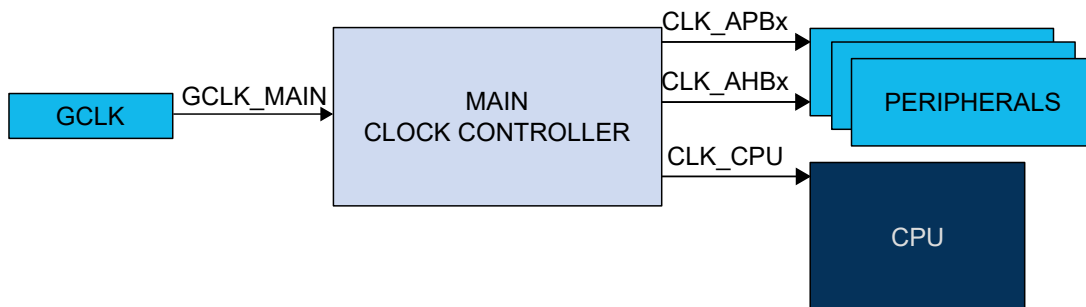
Using a clock provided by the Generic Clock Module (GCLK\_MAIN), the Main Clock Controller provides synchronous system clocks to the CPU and the modules connected to the AHBx and the APBx bus. The synchronous system clocks are divided into a number of clock domains. Each clock domain can run at different frequencies, enabling the user to save power by running peripherals at a relatively low clock frequency, while maintaining high CPU performance or vice versa. In addition, the clock can be masked for individual modules, enabling the user to minimize power consumption.

### 15.2 Features

- Generates CPU, AHB, and APB system clocks
  - Clock source and division factor from GCLK
  - Clock prescaler with 1x to 128x division
- Safe run-time clock switching from GCLK
- Module-level clock gating through maskable peripheral clocks

### 15.3 Block Diagram

Figure 15-1. MCLK Block Diagram



### 15.4 Signal Description

Not applicable.

### 15.5 Product Dependencies

In order to use this peripheral, other parts of the system must be configured correctly, as described below.

#### 15.5.1 I/O Lines

Not applicable.

### 15.5.2 Power Management

The MCLK will operate in all sleep modes if a synchronous clock is required in these modes.

#### Related Links

[18. PM – Power Manager](#)

### 15.5.3 Clocks

The MCLK bus clock (CLK\_MCLK\_APB) can be enabled and disabled in the Main Clock module, and the default state of CLK\_MCLK\_APB can be found in the Peripheral Clock Masking section. If this clock is disabled, it can only be re-enabled by a reset.

The Generic Clock GCLK\_MAIN is required to generate the Main Clocks. GCLK\_MAIN is configured in the Generic Clock Controller, and can be re-configured by the user if needed.

#### Related Links

[14. GCLK - Generic Clock Controller](#)

#### 15.5.3.1 Main Clock

The main clock CLK\_MAIN is the common source for the synchronous clocks. This is fed into the common 8-bit prescaler that is used to generate synchronous clocks to the CPU, AHBx, and APBx modules.

#### 15.5.3.2 CPU Clock

The CPU clock (CLK\_CPU) is routed to the CPU. Halting the CPU clock inhibits the CPU from executing instructions.

#### 15.5.3.3 APBx and AHBx Clock

The APBx clocks (CLK\_APBx) and the AHBx clocks (CLK\_AHBx) are the root clock source used by modules requiring a clock on the APBx and the AHBx bus. These clocks are always synchronous to the CPU clock, and can run even when the CPU clock is turned off in sleep mode. A clock gater is inserted after the common APB clock to gate any APBx clock of a module on APBx bus, as well as the AHBx clock.

#### 15.5.3.4 Clock Domains

The device has these synchronous clock domains:

- High-Speed synchronous clock domain (HS Clock Domain). Frequency is  $f_{HS}$ .
- CPU synchronous clock domain (CPU Clock Domain). Frequency is  $f_{CPU}$ .

See also the related links for the clock domain partitioning.

### 15.5.4 DMA

Not applicable.

### 15.5.5 Interrupts

The interrupt request line is connected to the Interrupt Controller. Using the MCLK interrupt requires the Interrupt Controller to be configured first.

### 15.5.6 Events

Not applicable.

### 15.5.7 Debug Operation

When the CPU is halted in debug mode, the MCLK continues normal operation. In sleep mode, the clocks generated from the MCLK are kept running to allow the debugger accessing any module. As a consequence, power measurements are incorrect in debug mode.

### 15.5.8 Register Access Protection

All registers with write access can be write-protected optionally by the Peripheral Access Controller (PAC), except for the following registers:

- Interrupt Flag register (INTFLAG)

Optional write protection by the Peripheral Access Controller (PAC) is denoted by the "PAC Write Protection" property in each individual register description.

PAC write protection does not apply to accesses through an external debugger.

#### Related Links

[27. PAC - Peripheral Access Controller](#)

### 15.5.9 Analog Connections

Not applicable.

## 15.6 Functional Description

### 15.6.1 Principle of Operation

The CLK\_MAIN clock signal from the GCLK module is the source for the main clock, which in turn is the common root for the synchronous clocks for the CPU, APBx, and AHBx modules. The CLK\_MAIN is divided by an 8-bit prescaler. Each of the derived clocks can run from any divided or undivided main clock, ensuring synchronous clock sources for each clock domain. The clock domain (CPU) can be changed on the fly to respond to variable load in the application. The clocks for each module in a clock domain can be masked individually to avoid power consumption in inactive modules. Depending on the sleep mode, some clock domains can be turned off.

### 15.6.2 Basic Operation

#### 15.6.2.1 Initialization

After a Reset, the default clock source of the CLK\_MAIN clock (GCLK\_MAIN) is started and calibrated before the CPU starts running. The GCLK\_MAIN clock is selected as the main clock without any prescaler division.

By default, only the necessary clocks are enabled.

#### 15.6.2.2 Enabling, Disabling, and Resetting

The MCLK module is always enabled and cannot be reset.

#### 15.6.2.3 Selecting the Main Clock Source

Refer to the Generic Clock Controller description for details on how to configure the clock source of the GCLK\_MAIN clock.

#### Related Links

[14. GCLK - Generic Clock Controller](#)

### 15.6.2.4 Selecting the Synchronous Clock Division Ratio

The main clock GCLK\_MAIN feeds an 8-bit prescaler, which can be used to generate the synchronous clocks. By default, the synchronous clocks run on the undivided main clock. The user can select a prescaler division for the CPU clock domain by writing the Division (DIV) bits in the CPU Clock Division register CPUDIV, resulting in a CPU clock domain frequency determined by this equation:

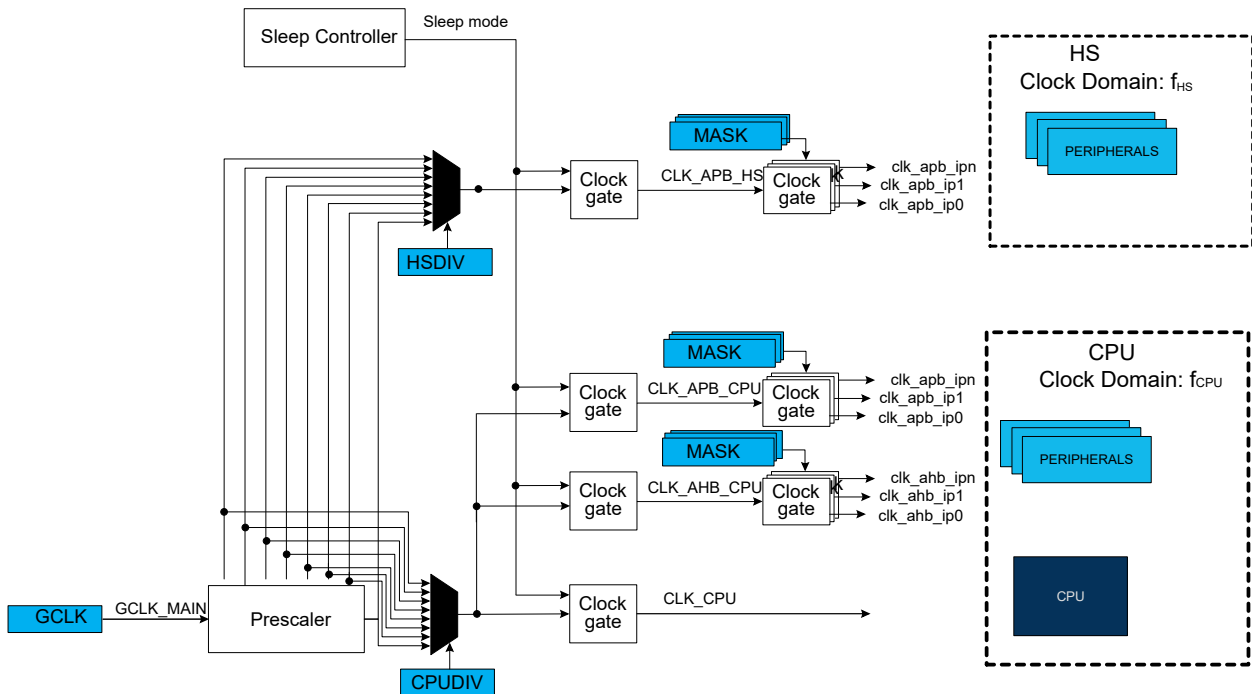
$$f_{CPU} = \frac{f_{main}}{CPUDIV}$$

Frequencies must never exceed the specified maximum frequency for each clock domain given in the electrical characteristics specifications.

If the application attempts to write forbidden values in CPUDIV register, register is written but these bad values are not used and a violation is reported to the PAC module.

Division bits (DIV) can be written without halting or disabling peripheral modules. Writing DIV bits allows a new clock setting to be written to all synchronous clocks belonging to the corresponding clock domain at the same time.

**Figure 15-2. Synchronous Clock Selection and Prescaler**



**Note:** A FAST clock for QSPI (CLK\_QSPI2X\_AHB) is derived from high-speed synchronous  $f_{HS}$ .

#### Related Links

[27. PAC - Peripheral Access Controller](#)

### 15.6.2.5 Clock Ready Flag

There is a slight delay between writing to CPUDIV until the new clock settings become effective.

During this interval, the Clock Ready flag in the Interrupt Flag Status and Clear register (INTFLAG.CKRDY) will return zero when read. If CKRDY in the INTENSET register is set to '1', the Clock Ready interrupt will be triggered when the new clock setting is effective. The clock settings (CLKCFG) must not be re-written while INTFLAG.CKRDY reads '0'. The system may become unstable or hang, and a violation is reported to the PAC module.

### Related Links

[27. PAC - Peripheral Access Controller](#)

#### 15.6.2.6 Peripheral Clock Masking

It is possible to disable/enable the AHB or APB clock for a peripheral by writing the corresponding bit in the Clock Mask registers (APBxMASK) to '0'/'1'. The default state of the peripheral clocks is shown here.

**Table 15-1. Peripheral Clock Default State**

CPU Clock Domain	
Peripheral Clock	Default State
CLK_AC_APB	Disabled
CLK_ADC0_APB	Enabled
CLK_ADC1_APB	Enabled
CLK_AES_APB	Disabled
CLK_BRIDGE_A_AHB	Enabled
CLK_BRIDGE_B_AHB	Enabled
CLK_BRIDGE_C_AHB	Enabled
CLK_BRIDGE_D_AHB	Enabled
CLK_CAN0_AHB	Enabled
CLK_CAN1_AHB	Enabled
CLK_CMCC_AHB	Enabled
CLK_DMAC_AHB	Enabled
CLK_DSU_AHB	Enabled
CLK_EIC_APB	Enabled
CLK_EVSYS_APB	Disabled
CLK_FREQM_APB	Disabled
CLK_GCLK_APB	Enabled
CLK_GMAC_AHB	Enabled
CLK_GMAC_APB	Disabled
CLK_ICM_AHB	Enabled
CLK_I2S_AHB	Disabled
CLK_MCLK_APB	Enabled
CLK_NVMCTRL_AHB	Enabled
CLK_NVMCTRL_APB	Enabled
CLK_OSCCTRL_APB	Enabled
CLK_PAC_AHB	Enabled

# SAM D5x/E5x Family Data Sheet

## MCLK – Main Clock

.....continued

CPU Clock Domain	
Peripheral Clock	Default State
CLK_PAC_APB	Enabled
CLK_PDEC_APB	Disabled
CLK_PORT_APB	Enabled
CLK_PTC_APB	Enabled
CLK_PUKCC_AHB	Enabled
CLK_QSPI_AHB	Enabled
CLK_QSPI2X_AHB	Enabled
CLK_SDHC0_AHB	Enabled
CLK_SDHC1_AHB	Enabled
CLK_SERCOM0_APB	Disabled
CLK_SERCOM1_APB	Disabled
CLK_SERCOM2_APB	Disabled
CLK_SERCOM3_APB	Disabled
CLK_SERCOM4_APB	Disabled
CLK_SERCOM5_APB	Disabled
CLK_SERCOM6_APB	Disabled
CLK_SERCOM7_APB	Disabled
CLK_TC0_APB	Disabled
CLK_TC1_APB	Disabled
CLK_TC2_APB	Disabled
CLK_TC3_APB	Disabled
CLK_TC4_APB	Disabled
CLK_TC5_APB	Disabled
CLK_TC6_APB	Disabled
CLK_TC7_APB	Disabled
CLK_TCC0_APB	Disabled
CLK_TCC1_APB	Disabled
CLK_TCC2_APB	Disabled
CLK_TCC3_APB	Disabled
CLK_TCC4_APB	Disabled

.....continued	
CPU Clock Domain	
Peripheral Clock	Default State
CLK_USB_AHB	Enabled
CLK_USB_APB	Disabled
CLK_WDT_APB	Enabled
CLK_DAC_APB	Disabled
CLK_DSU_APB	Enabled
CLK_CCL_APB	Disabled
CLK_QSPI_APB	Enabled
CLK_ICM_APB	Disabled
CLK_TRNG_APB	Disabled
Backup Clock Domain	
Peripheral Clock	Default State
CLK_OSC32KCTRL_APB	Enabled
CLK_PM_APB	Enabled
CLK_SUPC_APB	Enabled
CLK_RSTC_APB	Enabled
CLK_RTC_APB	Enabled

When the APB clock is not provided to a module, its registers cannot be read or written. The module can be re-enabled later by writing the corresponding mask bit to '1'.

A module may be connected to several clock domains (for instance, AHB and APB), in which case it will have several mask bits.

Note that clocks should only be switched off if it is certain that the module will not be used: Switching off the clock for the NVM Controller (NVMCTRL) will cause a problem if the CPU needs to read from the Flash Memory. Switching off the clock to the MCLK module (which contains the mask registers) or the corresponding APBx bridge, will make it impossible to write the mask registers again. In this case, they can only be re-enabled by a system reset.

### 15.6.3 DMA Operation

Not applicable.

### 15.6.4 Interrupts

The peripheral has the following interrupt sources:

- Clock Ready (CKRDY): indicates that CPU clocks are ready. This interrupt is a synchronous wake-up source.

Each interrupt source has an interrupt flag associated with it. The interrupt flag in the Interrupt Flag Status and Clear (**INTFLAG**) register is set when the interrupt condition occurs. Each interrupt can be enabled



individually by writing a '1' to the corresponding enabling bit in the Interrupt Enable Set ([INTENSET](#)) register, and disabled by writing a '1' to the corresponding clearing bit in the Interrupt Enable Clear ([INTENCLR](#)) register.

An interrupt request is generated when the interrupt flag is set and the corresponding interrupt is enabled. The interrupt request remains active until the interrupt flag is cleared, the interrupt is disabled or the peripheral is reset. An interrupt flag is cleared by writing a '1' to the corresponding bit in the [INTFLAG](#) register. Each peripheral can have one interrupt request line per interrupt source or one common interrupt request line for all the interrupt sources. If the peripheral has one common interrupt request line for all the interrupt sources, the user must read the [INTFLAG](#) register to determine which interrupt condition is present.

### Related Links

[18. PM – Power Manager](#)

[10.2.1 Overview](#)

### 15.6.5 Events

Not applicable.

### 15.6.6 Sleep Mode Operation

In IDLE sleep mode, the MCLK is still running on the selected main clock.

In STANDBY sleep mode, the MCLK is frozen if no synchronous clock is required.

### 15.7 Register Summary

Offset	Name	Bit Pos.								
0x00	<a href="#">CTRLA</a>	7:0								
0x01	<a href="#">INTENCLR</a>	7:0								CKRDY
0x02	<a href="#">INTENSET</a>	7:0								CKRDY
0x03	<a href="#">INTFLAG</a>	7:0								CKRDY
0x04	<a href="#">HSDIV</a>	7:0	DIV[7:0]							
0x05	<a href="#">CPUDIV</a>	7:0	DIV[7:0]							
0x06 ... 0x0F	Reserved									
0x10	<a href="#">AHBMASK</a>	7:0	Reserved	NVMCTRL	Reserved	DSU	HPBn3	HPBn2	HPBn1	HPBn0
		15:8	SDHCn0	GMAC	QSPI	PAC	Reserved	USB	DMAC	CMCC
		23:16	NVMCTRL_C ACHE	NVMCTRL_S MEEPROM	QSPI_2X	PUKCC	ICM	CANn1	CANn0	SDHCn1
		31:24								
0x14	<a href="#">APBAMASK</a>	7:0	GCLK	SUPC	OSC32KCTRL L	OSCCTRL	RSTC	MCLK	PM	PAC
		15:8	TCn1	TCn0	SERCOM1	SERCOM0	FREQM	EIC	RTC	WDT
		23:16								
		31:24								
0x18	<a href="#">APBBMASK</a>	7:0	EVSYS			PORT		NVMCTRL	DSU	USB
		15:8		TCn3	TCn2	TCCn1	TCCn0	SERCOM3	SERCOM2	
		23:16								RAMECC
		31:24								
0x1C	<a href="#">APBCMASK</a>	7:0	PDEC	TCn5	TCn4	TCCn3	TCCn2	GMAC		
		15:8		CCL	QSPI		ICM	TRNG	AES	AC
		23:16								
		31:24								
0x20	<a href="#">APBDMASK</a>	7:0	ADCn0	TC7	TC6	TCC4	SERCOM7	SERCOM6	SERCOM5	SERCOM4
		15:8					PCC	I2S	DAC	ADCn1
		23:16								
		31:24								

### 15.8 Register Description

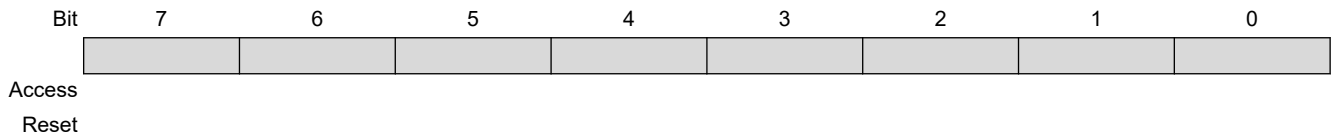
Registers can be 8, 16, or 32 bits wide. Atomic 8-, 16-, and 32-bit accesses are supported. In addition, the 8-bit quarters and 16-bit halves of a 32-bit register, and the 8-bit halves of a 16-bit register can be accessed directly.

Some registers can be write-protected optionally by the Peripheral Access Controller (PAC). This is denoted by the property "PAC Write-Protection" in each individual register description. Refer to the [15.5.8 Register Access Protection](#) for details.

### 15.8.1 Control A

**Name:** CTRLA  
**Offset:** 0x00  
**Reset:** 0x00  
**Property:** PAC Write-Protection

All bits in this register are reserved.



### 15.8.2 Interrupt Enable Clear

**Name:** INTENCLR  
**Offset:** 0x01  
**Reset:** 0x00  
**Property:** PAC Write-Protection

This register allows the user to disable an interrupt without doing a read-modify-write operation. Changes in this register will also be reflected in the Interrupt Enable Set (INTENSET) register.

	7	6	5	4	3	2	1	0
								CKRDY
Access								R/W
Reset								0

**Bit 0 – CKRDY** Clock Ready Interrupt Enable

Writing a '0' to this bit has no effect.

Writing a '1' to this bit will clear the Clock Ready Interrupt Enable bit and the corresponding interrupt request.

Value	Description
0	The Clock Ready interrupt is enabled and will generate an interrupt request when the Clock Ready Interrupt Flag is set.
1	The Clock Ready interrupt is disabled.

### 15.8.3 Interrupt Enable Set

**Name:** INTENSET  
**Offset:** 0x02  
**Reset:** 0x00  
**Property:** PAC Write-Protection

This register allows the user to enable an interrupt without doing a read-modify-write operation. Changes in this register will also be reflected in the Interrupt Enable Clear (INTENCLR) register.

	7	6	5	4	3	2	1	0
								CKRDY
Access								R/W
Reset								0

**Bit 0 – CKRDY** Clock Ready Interrupt Enable

Writing a '0' to this bit has no effect.

Writing a '1' to this bit will set the Clock Ready Interrupt Enable bit and enable the Clock Ready interrupt.

Value	Description
0	The Clock Ready interrupt is disabled.
1	The Clock Ready interrupt is enabled.

### 15.8.4 Interrupt Flag Status and Clear

**Name:** INTFLAG  
**Offset:** 0x03  
**Reset:** 0x01  
**Property:** –

Bit	7	6	5	4	3	2	1	0
								CKRDY
Access								R/W
Reset								1

**Bit 0 – CKRDY** Clock Ready

This flag is cleared by writing a '1' to the flag.

This flag is set when the synchronous CPU, APBx, and AHBx clocks have frequencies as indicated in the CLKCFG registers and will generate an interrupt if [INTENCLR/SET.CKRDY](#) is '1'.

Writing a '0' to this bit has no effect.

Writing a '1' to this bit clears the Clock Ready interrupt flag.

### 15.8.5 High-Speed Clock Division

**Name:** HSDIV  
**Offset:** 0x04  
**Reset:** 0x01

Bit	7	6	5	4	3	2	1	0
	DIV[7:0]							
Access	R	R	R	R	R	R	R	R
Reset	0	0	0	0	0	0	0	1

**Bits 7:0 – DIV[7:0]** HS Clock Division Factor

These bits define the division ratio of the main clock prescaler related to the HS clock domain (HSDIV).

Value	Name	Description
0x01	DIV1	Divide by 1
others	-	Reserved

### 15.8.6 CPU Clock Division

**Name:** CPUDIV  
**Offset:** 0x05  
**Reset:** 0x01  
**Property:** PAC Write-Protection

Bit	7	6	5	4	3	2	1	0
	DIV[7:0]							
Access	R/W	R/W	R/W	R/W	R/W	R/W	R/W	R/W
Reset	0	0	0	0	0	0	0	1

#### Bits 7:0 – DIV[7:0] CPU Clock Division Factor

These bits define the division ratio of the main clock prescaler related to the CPU clock domain (CPUDIV).

To ensure correct operation, frequencies must be selected so that  $f_{HS} \geq f_{CPU}$  (i.e.  $CPUDIV \geq HSDIV$ ).

Frequencies must never exceed the specified maximum frequency for each clock domain.

Value	Name	Description
0x01	DIV1	Divide by 1
0x02	DIV2	Divide by 2
0x04	DIV4	Divide by 4
0x08	DIV8	Divide by 8
0x10	DIV16	Divide by 16
0x20	DIV32	Divide by 32
0x40	DIV64	Divide by 64
0x80	DIV128	Divide by 128
others	-	Reserved



### 15.8.7 AHB Mask

**Name:** AHBMASK  
**Offset:** 0x10  
**Reset:** 0x00FFFFFF  
**Property:** PAC Write-Protection

	31	30	29	28	27	26	25	24
Access	[Greyed out]							
Reset	[Greyed out]							
	23	22	21	20	19	18	17	16
Access	R/W	R/W	R/W	R/W	R/W	R/W	R/W	R/W
Reset	1	1	1	1	1	1	1	1
	15	14	13	12	11	10	9	8
Access	R/W	R/W	R/W	R/W	R	R/W	R/W	R/W
Reset	1	1	1	1	1	1	1	1
	7	6	5	4	3	2	1	0
Access	R	R/W	R	R/W	R/W	R/W	R/W	R/W
Reset	1	1	1	1	1	1	1	1

#### Bit 23 – NVMCTRL\_CACHE NVMCTRL\_CACHE AHB Clock Enable

Value	Description
0	The AHB clock for the NVMCTRL_CACHE is stopped.
1	The AHB clock for the NVMCTRL_CACHE is enabled.

#### Bit 22 – NVMCTRL\_SMEEPROM NVMCTRL\_SMEEPROM AHB Clock Enable

Value	Description
0	The AHB clock for the NVMCTRL_SMEEPROM is stopped.
1	The AHB clock for the NVMCTRL_SMEEPROM is enabled.

#### Bit 21 – QSPI\_2X QSPI\_2X AHB Clock Enable

Value	Description
0	The AHB clock for the QSPI_2X is stopped.
1	The AHB clock for the QSPI_2X is enabled.

#### Bit 20 – PUKCC PUKCC AHB Clock Enable

Value	Description
0	The AHB clock for the PUKCC is stopped.
1	The AHB clock for the PUKCC is enabled.

#### Bit 19 – ICM ICM AHB Clock Enable

Value	Description
0	The AHB clock for the ICM is stopped.
1	The AHB clock for the ICM is enabled.

**Bits 17, 18 – CANn** CANn AHB Clock Enable

Value	Description
0	The AHB clock for the CANn is stopped.
1	The AHB clock for the CANn is enabled.

**Bits 15, 16 – SDHCn** SDHCn AHB Clock Enable

Value	Description
0	The AHB clock for the SDHCn is stopped.
1	The AHB clock for the SDHCn is enabled.

**Bit 14 – GMAC** GMAC AHB Clock Enable

Value	Description
0	The AHB clock for the GMAC is stopped.
1	The AHB clock for the GMAC is enabled.

**Bit 13 – QSPI** QSPI AHB Clock Enable

Value	Description
0	The AHB clock for the QSPI is stopped.
1	The AHB clock for the QSPI is enabled.

**Bit 12 – PAC** PAC AHB Clock Enable

Value	Description
0	The AHB clock for the PAC is stopped.
1	The AHB clock for the PAC is enabled.

**Bits 11,7,5 – Reserved** Reserved bits

Reserved bits are unused and reserved for future use. For compatibility with future devices, always write reserved bits to their reset value. If no reset value is given, write 0.

**Bit 10 – USB** USB AHB Clock Enable

Value	Description
0	The AHB clock for the USB is stopped.
1	The AHB clock for the USB is enabled.

**Bit 9 – DMAC** DMAC AHB Clock Enable

Value	Description
0	The AHB clock for the DMAC is stopped.
1	The AHB clock for the DMAC is enabled.

**Bit 8 – CMCC** CMCC AHB Clock Enable

Value	Description
0	The AHB clock for the CMCC is stopped.
1	The AHB clock for the CMCC is enabled.

**Bit 6 – NVMCTRL** NVMCTRL AHB Clock Enable

# SAM D5x/E5x Family Data Sheet

## MCLK – Main Clock

---

---

Value	Description
0	The AHB clock for the NVMCTRL is stopped.
1	The AHB clock for the NVMCTRL is enabled.

### Bit 4 – DSU DSU AHB Clock Enable

Value	Description
0	The AHB clock for the DSU is stopped.
1	The AHB clock for the DSU is enabled.

### Bits 0, 1, 2, 3 – HPBn HPBn AHB Clock Enable

Value	Description
0	The AHB clock for the HPBn is stopped.
1	The AHB clock for the APBn is enabled.

### 15.8.8 APBA Mask

**Name:** APBAMASK  
**Offset:** 0x14  
**Reset:** 0x000007FF  
**Property:** PAC Write-Protection

	31	30	29	28	27	26	25	24
	<div style="border: 1px solid black; height: 15px; width: 100%;"></div>							
Access								
Reset								
	23	22	21	20	19	18	17	16
	<div style="border: 1px solid black; height: 15px; width: 100%;"></div>							
Access								
Reset								
	15	14	13	12	11	10	9	8
	<div style="border: 1px solid black; height: 15px; width: 100%;"></div>							
Access								
Reset								
	7	6	5	4	3	2	1	0
	<div style="border: 1px solid black; height: 15px; width: 100%;"></div>							
Access								
Reset								

#### Bits 14, 15 – TCn TCn APBA Clock Enable

Value	Description
0	The APBA clock for the TCn is stopped.
1	The APBA clock for the TCn is enabled.

#### Bits 12, 13 – SERCOM SERCOMn APBA Clock Enable

Value	Description
0	The APBA clock for the SERCOMn is stopped.
1	The APBA clock for the SERCOMn is enabled.

#### Bit 11 – FREQM FREQM APBA Clock Enable

Value	Description
0	The APBA clock for the FREQM is stopped.
1	The APBA clock for the FREQM is enabled.

#### Bit 10 – EIC EIC APBA Clock Enable

Value	Description
0	The APBA clock for the EIC is stopped.
1	The APBA clock for the EIC is enabled.

#### Bit 9 – RTC RTC APBA Clock Enable

Value	Description
0	The APBA clock for the RTC is stopped.
1	The APBA clock for the RTC is enabled.

**Bit 8 – WDT** WDT APBA Clock Enable

Value	Description
0	The APBA clock for the WDT is stopped.
1	The APBA clock for the WDT is enabled.

**Bit 7 – GCLK** GCLK APBA Clock Enable

Value	Description
0	The APBA clock for the GCLK is stopped.
1	The APBA clock for the GCLK is enabled.

**Bit 6 – SUPC** SUPC APBA Clock Enable

Value	Description
0	The APBA clock for the SUPC is stopped.
1	The APBA clock for the SUPC is enabled.

**Bit 5 – OSC32KCTRL** OSC32KCTRL APBA Clock Enable

Value	Description
0	The APBA clock for the OSC32KCTRL is stopped.
1	The APBA clock for the OSC32KCTRL is enabled.

**Bit 4 – OSCCTRL** OSCCTRL APBA Clock Enable

Value	Description
0	The APBA clock for the OSCCTRL is stopped.
1	The APBA clock for the OSCCTRL is enabled.

**Bit 3 – RSTC** RSTC APBA Clock Enable

Value	Description
0	The APBA clock for the RSTC is stopped.
1	The APBA clock for the RSTC is enabled.

**Bit 2 – MCLK** MCLK APBA Clock Enable

Value	Description
0	The APBA clock for the MCLK is stopped.
1	The APBA clock for the MCLK is enabled.

**Bit 1 – PM** PM APBA Clock Enable

Value	Description
0	The APBA clock for the PM is stopped.
1	The APBA clock for the PM is enabled.

**Bit 0 – PAC** PAC APBA Clock Enable

Value	Description
0	The APBA clock for the PAC is stopped.
1	The APBA clock for the PAC is enabled.

### 15.8.9 APBB Mask

**Name:** APBBMASK  
**Offset:** 0x18  
**Reset:** 0x00018056  
**Property:** PAC Write-Protection

	31	30	29	28	27	26	25	24	
Access									
Reset									
	23	22	21	20	19	18	17	16	
Access								RAMECC	
Reset								R/W	
								1	
	15	14	13	12	11	10	9	8	
Access			TCn3	TCn2	TCCn1	TCCn0	SERCOM3	SERCOM2	
Reset			R/W	R/W	R/W	R/W	R/W	R/W	
			0	0	0	0	0	0	
	7	6	5	4	3	2	1	0	
Access				PORT		NVMCTRL	DSU	USB	
Reset				R/W		R/W	R/W	R/W	
				0		1	1	0	

#### Bit 16 – RAMECC RAMECC APBB Clock Enable

Value	Description
0	The APBB clock for the RAMECC is stopped.
1	The APBB clock for the RAMECC is enabled.

#### Bits 13, 14 – TCn TCn APBB Clock Enable

Value	Description
0	The APBB clock for the TCn is stopped.
1	The APBB clock for the TCn is enabled.

#### Bits 11, 12 – TCCn TCCn APBB Clock Enable

Value	Description
0	The APBB clock for the TCCn is stopped.
1	The APBB clock for the TCCn is enabled.

#### Bits 9, 10 – SERCOM SERCOMn APBB Clock Enable

Value	Description
0	The APBB clock for the SERCOMn is stopped.
1	The APBB clock for the SERCOMn is enabled.

#### Bit 7 – EVSYS EVSYS APBB Clock Enable

Value	Description
0	The APBB clock for the EVSYS is stopped.
1	The APBB clock for the EVSYS is enabled.

### Bit 4 – PORT PORT APBB Clock Enable

Value	Description
0	The APBB clock for the PORT is stopped.
1	The APBB clock for the PORT is enabled.

### Bit 2 – NVMCTRL NVMCTRL APBB Clock Enable

Value	Description
0	The APBB clock for the NVMCTRL is stopped.
1	The APBB clock for the NVMCTRL is enabled.

### Bit 1 – DSU DSU APBB Clock Enable

Value	Description
0	The APBB clock for the DSU is stopped.
1	The APBB clock for the DSU is enabled.

### Bit 0 – USB USB APBB Clock Enable

Value	Description
0	The APBB clock for the USB is stopped.
1	The APBB clock for the USB is enabled.

### 15.8.10 APBC Mask

**Name:** APBCMASK  
**Offset:** 0x1C  
**Reset:** 0x00002000  
**Property:** PAC Write-Protection

	31	30	29	28	27	26	25	24
Access								
Reset								
	23	22	21	20	19	18	17	16
Access								
Reset								
	15	14	13	12	11	10	9	8
		CCL	QSPI		ICM	TRNG	AES	AC
Access		R/W	R/W		R/W	R/W	R/W	R/W
Reset		0	1		0	0	0	0
	7	6	5	4	3	2	1	0
	PDEC	TCn5	TCn4	TCCn3	TCCn2	GMAC		
Access	R/W	R/W	R/W	R/W	R/W	R/W		
Reset	0	0	1	0	0	1		

#### Bit 14 – CCL CCL APBC Mask Clock Enable

Value	Description
0	The APBC clock for the CCL is stopped.
1	The APBC clock for the CCL is enabled.

#### Bit 13 – QSPI QSPI APBC Mask Clock Enable

Value	Description
0	The APBC clock for the QSPI is stopped.
1	The APBC clock for the QSPI is enabled.

#### Bit 11 – ICM ICM APBC Mask Clock Enable

Value	Description
0	The APBC clock for the ICM is stopped.
1	The APBC clock for the ICM is enabled.

#### Bit 10 – TRNG TRNG APBC Mask Clock Enable

Value	Description
0	The APBC clock for the TRNG is stopped.
1	The APBC clock for the TRNG is enabled.

#### Bit 9 – AES AES APBC Mask Clock Enable



# SAM D5x/E5x Family Data Sheet

## MCLK – Main Clock

Value	Description
0	The APBC clock for the AES is stopped.
1	The APBC clock for the AES is enabled.

### Bit 8 – AC AC APBC Mask Clock Enable

Value	Description
0	The APBC clock for the AC is stopped.
1	The APBC clock for the AC is enabled.

### Bit 7 – PDEC PDEC APBC Mask Clock Enable

Value	Description
0	The APBC clock for the PDEC is stopped.
1	The APBC clock for the PDEC is enabled.

### Bits 5, 6 – TCn TCn APBC Mask Clock Enable

Value	Description
0	The APBC clock for the TCn is stopped.
1	The APBC clock for the TCn is enabled.

### Bits 3, 4 – TCCn TCCn APBC Mask Clock Enable

Value	Description
0	The APBC clock for the TCCn is stopped.
1	The APBC clock for the TCCn is enabled.

### Bit 2 – GMAC GMAC APBC Mask Clock Enable

Value	Description
0	The APBC clock for the GMAC is stopped.
1	The APBC clock for the GMAC is enabled.

### 15.8.11 APBD Mask

**Name:** APBDMASK  
**Offset:** 0x20  
**Reset:** 0x00000000  
**Property:** PAC Write-Protection

	31	30	29	28	27	26	25	24	
Access									
Reset									
	23	22	21	20	19	18	17	16	
Access									
Reset									
	15	14	13	12	11	10	9	8	
					PCC	I2S	DAC	ADCn1	
Access					R/W	R/W	R	R/W	
Reset					0	0	0	0	
	7	6	5	4	3	2	1	0	
	ADCn0	TC7	TC6	TCC4	SERC0M7	SERC0M6	SERC0M5	SERC0M4	
Access	R/W	R/W	R/W	R/W	R/W	R/W	R/W	R/W	
Reset	0	0	0	0	0	0	0	0	

#### Bit 11 – PCC PCC APBD Mask Clock Enable

Value	Description
0	The APBD clock for the PCC is stopped.
1	The APBD clock for the PCC is enabled.

#### Bit 10 – I2S I2S APBD Mask Clock Enable

Value	Description
0	The APBD clock for the I2S is stopped.
1	The APBD clock for the I2S is enabled.

#### Bit 9 – DAC DAC APBD Mask Clock Enable

Value	Description
0	The APBD clock for the DAC is stopped.
1	The APBD clock for the DAC is enabled.

#### Bits 7, 8 – ADCn ADCn APBD Mask Clock Enable

Value	Description
0	The APBD clock for the ADCn is stopped.
1	The APBD clock for the ADCn is enabled.

#### Bits 5, 6 – TC TCn APBD Mask Clock Enable

---

---

Value	Description
0	The APBD clock for the TCn is stopped.
1	The APBD clock for the TCn is enabled.

### Bit 4 – TCC4 TCC4 APBD Mask Clock Enable

Value	Description
0	The APBD clock for the TCC4 is stopped.
1	The APBD clock for the TCC4 is enabled.

### Bits 0, 1, 2, 3 – SERCOMn SERCOMn APBD Mask Clock Enable

Value	Description
0	The APBD clock for the SERCOMn is stopped.
1	The APBD clock for the SERCOMn is enabled.

## 16. RSTC – Reset Controller

### 16.1 Overview

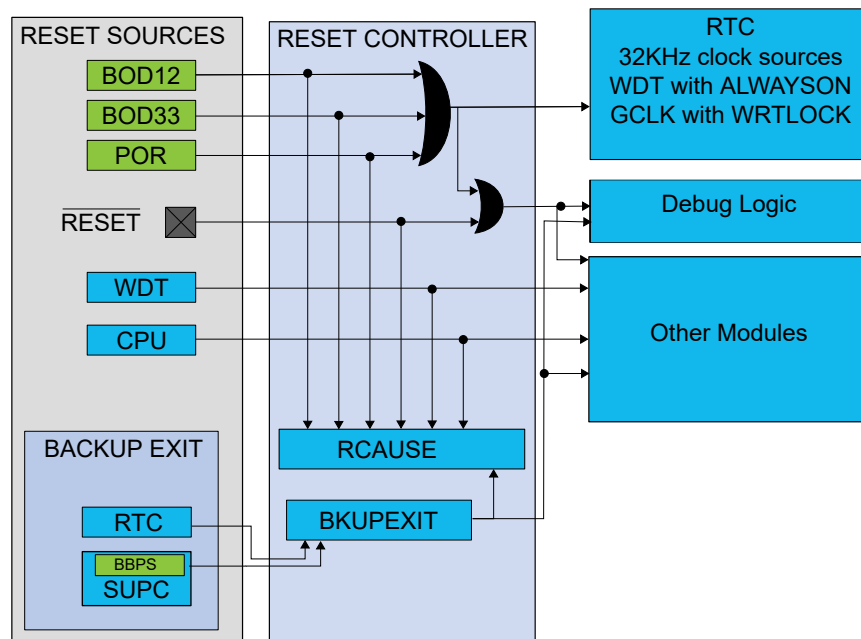
The Reset Controller (RSTC) manages the reset of the microcontroller. It issues a microcontroller reset, sets the device to its initial state and allows the reset source to be identified by software.

### 16.2 Features

- Reset the microcontroller and set it to an initial state according to the reset source
- Reset cause register for reading the reset source from the application code
- Multiple reset sources
  - Power supply reset sources: POR, BOD12, BOD33
  - User reset sources: External reset ( $\overline{\text{RESET}}$ ), Watchdog reset, and System Reset Request
  - Backup exit sources: Real-Time Counter (RTC) and Battery Backup Power Switch (BBPS)

### 16.3 Block Diagram

Figure 16-1. Reset System



### 16.4 Signal Description

Signal Name	Type	Description
$\overline{\text{RESET}}$	Digital input	External reset

One signal can be mapped on several pins.

### Related Links

[6. I/O Multiplexing and Considerations](#)

## 16.5 Product Dependencies

In order to use this peripheral, other parts of the system must be configured correctly, as described below.

### 16.5.1 I/O Lines

Not applicable.

### 16.5.2 Power Management

The Reset Controller module is always on.

### 16.5.3 Clocks

The RSTC bus clock (CLK\_RSTC\_APB) can be enabled and disabled in the Main Clock Controller.

### Related Links

[15. MCLK – Main Clock](#)

[15.6.2.6 Peripheral Clock Masking](#)

### 16.5.4 DMA

Not applicable.

### 16.5.5 Interrupts

Not applicable.

### 16.5.6 Events

Not applicable.

### 16.5.7 Debug Operation

When the CPU is halted in debug mode, the RSTC continues normal operation.

### 16.5.8 Register Access Protection

All registers with write access can be optionally write-protected by the Peripheral Access Controller (PAC).

**Note:** Optional write protection is indicated by the "PAC Write Protection" property in the register description.

Write protection does not apply for accesses through an external debugger.

### 16.5.9 Analog Connections

Not applicable.

## 16.6 Functional Description

### 16.6.1 Principle of Operation

The Reset Controller collects the various Reset sources and generates Reset for the device.

### 16.6.2 Basic Operation

#### 16.6.2.1 Initialization

After a power-on Reset, the RSTC is enabled and the Reset Cause (RCAUSE) register indicates the POR source.

#### 16.6.2.2 Enabling, Disabling, and Resetting

The RSTC module is always enabled.

#### 16.6.2.3 Reset Causes and Effects

The latest Reset cause is available in RCAUSE register, and can be read during the application boot sequence in order to determine proper action.

These are the groups of Reset sources:

- Power supply Reset: Resets caused by an electrical issue. It covers POR and BODs Resets
- User Reset: Resets caused by the application. It covers external Resets, system Reset requests and watchdog Resets
- Backup reset: Resets caused by a Backup Mode exit condition

The following table lists the parts of the device that are reset, depending on the Reset type.

**Table 16-1. Effects of the Different Reset Causes**

	Power Supply Reset	User Reset	
	POR, BOD33, BOD12	External Reset	WDT Reset, System Reset Request, NVM Reset
RTC, OSC32KCTRL, RSTC	Y	N	N
GCLK with WRTLOCK	Y	N	N
Debug logic	Y	Y	N
Others	Y	Y	Y

The external Reset is generated when pulling the  $\overline{\text{RESET}}$  pin low.

The POR, BOD12, and BOD33 Reset sources are generated by their corresponding module in the Supply Controller Interface (SUPC).

The WDT Reset is generated by the Watchdog Timer.

The System Reset Request is a Reset generated by the CPU when asserting the SYSRESETREQ bit located in the Reset Control register of the CPU (for details refer to the ARM® Cortex™ Technical Reference Manual on <http://www.arm.com>).

The NVM Reset is a Reset generated by the NVMCTRL when for example a BKSWRST command is performed (for details refer to NVMCTRL chapter).

From Backup Mode, the chip can be waken-up upon these conditions:

- Battery Backup Power Switch (BBPS): generated by the SUPC controller when the 3.3V VDDIO is restored.
- Real-Time Counter interrupt. For details refer to the applicable INTFLAG in the RTC for details.

If one of these conditions is triggered in Backup Mode, the RCAUSE.BACKUP bit is set and the Backup Exit Register (BKUPEXIT) is updated.

**Note:** Refer to the Timing Characteristics section of the Electrical Characteristics chapter.

### Related Links

[20. WDT – Watchdog Timer](#)

[19. SUPC – Supply Controller](#)

[19.6.3 Battery Backup Power Switch](#)

### 16.6.3 Additional Features

Not applicable.

### 16.6.4 DMA Operation

Not applicable.

### 16.6.5 Interrupts

Not applicable.

### 16.6.6 Events

Not applicable.

### 16.6.7 Sleep Mode Operation

The RSTC module is active in all sleep modes.

### 16.7 Register Summary

Offset	Name	Bit Pos.								
0x00	<a href="#">RCAUSE</a>	7:0	BACKUP	SYST	WDT	EXT	NVM	BOD33	BOD12	POR
0x01	Reserved									
0x02	<a href="#">BKUPEXIT</a>	7:0	HIB					BBPS	RTC	

### 16.8 Register Description

Registers can be 8, 16, or 32 bits wide. Atomic 8-, 16- and 32-bit accesses are supported. In addition, the 8-bit quarters and 16-bit halves of a 32-bit register, and the 8-bit halves of a 16-bit register can be accessed directly.

Some registers are optionally write-protected by the Peripheral Access Controller (PAC). Optional PAC write protection is denoted by the "PAC Write-Protection" property in each individual register description. For details, refer to [16.5.8 Register Access Protection](#).



### 16.8.1 Reset Cause

**Name:** RCAUSE  
**Offset:** 0x00  
**Property:** –

When a Reset occurs, the bit corresponding to the Reset source is set to '1' and all other bits are written to '0'.

Bit	7	6	5	4	3	2	1	0
	BACKUP	SYST	WDT	EXT	NVM	BOD33	BOD12	POR
Access	R	R	R	R	R	R	R	R
Reset	x	x	x	x	x	x	x	x

**Bit 7 – BACKUP** Backup Reset

This bit is set if either a Backup or Hibernate Reset has occurred. Refer to BKUPEXIT register to identify the source of the Backup Reset.

**Bit 6 – SYST** System Reset Request

This bit is set if a System Reset Request has occurred. Refer to the Cortex processor documentation for more details.

**Bit 5 – WDT** Watchdog Reset

This bit is set if a Watchdog Timer Reset has occurred.

**Bit 4 – EXT** External Reset

This bit is set if an external Reset has occurred.

**Bit 3 – NVM** NVM Reset

This bit is set if an NVM Reset has occurred.

**Bit 2 – BOD33** Brown Out 33 Detector Reset

This bit is set if a BOD33 Reset has occurred.

**Bit 1 – BOD12** Brown Out 12 Detector Reset

This bit is set if a BOD12 Reset has occurred.

**Bit 0 – POR** Power On Reset

This bit is set if a POR has occurred.

### 16.8.2 Backup Exit Source

**Name:** BKUPEXIT  
**Offset:** 0x02  
**Property:** –

When either a Hibernate or a Backup Reset occurs, the bit corresponding to the exit condition is set to '1', the other bits are written to '0'.

In some specific cases, the RTC and BBPS bits can be set together, e.g. when the device leaves the battery Backup Mode caused by a BBPS condition, and a RTC event was generated during the Battery Backup Mode period.

	7	6	5	4	3	2	1	0
Bit	HIB					BBPS	RTC	
Access	R					R	R	
Reset	x					x	x	

**Bit 7 – HIB** Hibernate

This bit is set if an Hibernate reset occurs. This bit is zero if a backup reset occurs.

**Bit 2 – BBPS** Battery Backup Power Switch

This bit is set if the Battery Backup Power Switch of the Supply Controller changes back from battery mode to main power mode.

**Bit 1 – RTC** Real Timer Counter Interrupt

This bit is set if an RTC interrupt flag is set in Backup Mode.

**Related Links**

- [19. SUPC – Supply Controller](#)
- [21. RTC – Real-Time Counter](#)

## 17. RAMECC – RAM Error Correction Code (ECC)

### 17.1 Overview

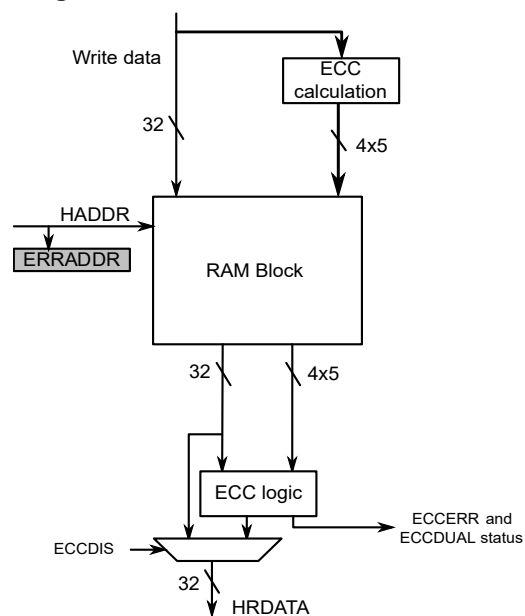
Single bit error correction and dual bit error detection is available for RAM.

### 17.2 Features

- Single bit correction and dual bit detection.
- Error Interrupt.

### 17.3 Block Diagram

Figure 17-1. RAMECC Block Diagram



### 17.4 Signal Description

Not applicable.

### 17.5 Product Dependencies

In order to use this peripheral, other parts of the system must be configured correctly, as described below.

#### 17.5.1 I/O Lines

Not applicable.

### 17.5.2 Power Management

The RAMECC will continue to operate in any sleep mode where the selected source clock is running. The RAMECC's interrupts can be used to wake up the device from sleep modes. Refer to the Power Manager chapter for details on the different sleep modes.

#### Related Links

[18. PM – Power Manager](#)

### 17.5.3 Clocks

The RAMECC bus clock is provided by the Main Clock Controller (MCLK) through the AHB-APB B bridge. The clock is enabled and disabled by writing RAMECC bit the in the APB B Mask register (MCLK.APBBMASK.RAMECC). See the register description for the default state of the RAMECC bus clock.

#### Related Links

[15.6.2.6 Peripheral Clock Masking](#)

### 17.5.4 DMA

Not applicable.

### 17.5.5 Interrupts

The interrupt request line is connected to the interrupt controller. Using the RAMECC interrupt(s) requires the interrupt controller to be configured first.

#### Related Links

[10.2 Nested Vector Interrupt Controller](#)

### 17.5.6 Events

Not applicable.

#### Related Links

[31. EVSYS – Event System](#)

### 17.5.7 Debug Operation

When the CPU is halted in debug mode the RAMECC will correct and log ECC errors based on the table below.

**Table 17-1. ECC Debug Operation**

DBGCTRL.ECCELOG	DBGCTRL.ECCDIS	Description
0	0	ECC errors from debugger reads are corrected but not logged in INTFLAG.
1	0	ECC errors from debugger reads are corrected and logged in INTFLAG.
X	1	ECC errors from debugger reads are not corrected or logged in INTFLAG.

If the RAMECC is configured in a way that requires it to be periodically serviced by the CPU through interrupts or similar, improper operation or data loss may result during debugging.

### 17.5.8 Register Access Protection

All registers with write-access are optionally write-protected by the peripheral access controller (PAC), except the following registers:

- Interrupt Flag Status and Clear (INTFLAG) register
- Status (STATUS) register.

Write-protection is denoted by the Write-Protected property in the register description.

Write-protection does not apply to accesses through an external debugger. Refer to the Peripheral Access Controller chapter for details.

### 17.5.9 Analog Connections

Not applicable.

## 17.6 Functional Description

### 17.6.1 Principle of Operation

Error Correcting Code (ECC) is implemented to detect and correct errors that may arise in the RAM arrays. The ECC logic is capable of double error detection and single error correction per 8-bit byte.

Upon single bit error detection, the Single Bit Error interrupt flag is raised (INTFLAG.SINGLEEE). If a dual error is detected, the Dual Error interrupt flag (INTFLAG.DUALE) is raised. When the first error is detected, the ERRADDR register is frozen with the failing address and remains frozen until INTFLAG.DUALE and INTFLAG.SINGLEEE are cleared. If a dual bit error occurs while INTFLAG.SINGLEEE is set, the ERRADDR register is updated with the dual bit error information and INTFLAG.DUALE is also set.

The INTFLAG.SINGLEEE and INTFLAG.DUALE bits are both cleared on ERRADDR read.

The block diagram shows the ECC interface. When ECC is disabled (CTRLA.ECCDIS=1), the ECC field in RAM is left unchanged on writes. On reads, ECC errors are not corrected or flagged.

#### Related Links

[17.3 Block Diagram](#)

### 17.6.2 Interrupts

The RAMECC has the following interrupt sources:

- Dual Bit Error (DUALE): Indicates that a dual bit error has been detected.
- Single Bit Error (SINGLEEE): Indicates that a single bit error has been detected.

Each interrupt source has an interrupt flag associated with it. The interrupt flag in the Interrupt Flag Status and Clear (INTFLAG) register is set when the interrupt condition occurs.

Each interrupt can be individually enabled by writing a '1' to the corresponding bit in the Interrupt Enable Set (INTENSET) register, and disabled by writing a '1' to the corresponding bit in the Interrupt Enable Clear (INTENCLR) register.

# SAM D5x/E5x Family Data Sheet

## RAMECC – RAM Error Correction Code (ECC)

---

An interrupt request is generated when the interrupt flag is set and the corresponding interrupt is enabled. The interrupt request remains active until the ERRADDR register is read, the interrupt is disabled, or the RAMECC is reset.

All interrupt requests from the peripheral are ORed together on system level to generate one combined interrupt request to the NVIC. The user must read the INTFLAG register to determine which interrupt condition is present.

**Note:** Interrupts must be globally enabled for interrupt requests to be generated.

### Related Links

[10.2 Nested Vector Interrupt Controller](#)

[17.8.3 INTFLAG](#)

# SAM D5x/E5x Family Data Sheet

## RAMECC – RAM Error Correction Code (ECC)

### 17.7 Register Summary

Offset	Name	Bit Pos.									
0x00	<a href="#">INTENCLR</a>	7:0							DUALE	SINGLEE	
0x01	<a href="#">INTENSET</a>	7:0							DUALE	SINGLEE	
0x02	<a href="#">INTFLAG</a>	7:0							DUALE	SINGLEE	
0x03	<a href="#">STATUS</a>	7:0								ECCDIS	
0x04	<a href="#">ERRADDR</a>	7:0	ERRADDR[7:0]								
		15:8	ERRADDR[15:8]								
		23:16									ERRADDR[16
		31:24									:16]
0x08 ... 0x0E	Reserved										
0x0F	<a href="#">DBGCTRL</a>	7:0							ECCELOG	ECCDIS	

### 17.8 Register Description

Registers can be 8, 16, or 32 bits wide. Atomic 8-, 16- and 32-bit accesses are supported. In addition, the 8-bit quarters and 16-bit halves of a 32-bit register, and the 8-bit halves of a 16-bit register can be accessed directly.

Some registers are optionally write-protected by the Peripheral Access Controller (PAC). Optional PAC write protection is denoted by the "PAC Write-Protection" property in each individual register description. For details, refer to [17.5.8 Register Access Protection](#).

# SAM D5x/E5x Family Data Sheet

## RAMECC – RAM Error Correction Code (ECC)

### 17.8.1 Interrupt Enable Clear

**Name:** INTENCLR  
**Offset:** 0x00  
**Reset:** 0x00  
**Property:** PAC Write-Protection

This register allows the user to disable an interrupt without doing a read-modify-write operation. Changes in this register will also be reflected in the Interrupt Enable Set (INTENSET) register.

	7	6	5	4	3	2	1	0
							DUALE	SINGLEE
Access							R/W	R/W
Reset							0	0

#### Bit 1 – DUALE Dual Bit Error Interrupt Enable Clear

Writing a '0' to this bit has no effect.

Writing a '1' to this bit will clear the Dual Bit Error Interrupt Enable bit, which disables the Dual Bit Error interrupt.

Value	Description
0	The Dual Bit Error interrupt is disabled.
1	The Dual Bit Error interrupt is enabled.

#### Bit 0 – SINGLEE Single Bit Error Interrupt Enable Clear

Writing a '0' to this bit has no effect.

Writing a '1' to this bit will clear the Single Bit Error Interrupt Enable bit, which disables the Single Bit Error interrupt.

Value	Description
0	The Single Bit Error interrupt is disabled.
1	The Single Bit Error interrupt is enabled.



# SAM D5x/E5x Family Data Sheet

## RAMECC – RAM Error Correction Code (ECC)

### 17.8.2 Interrupt Enable Set

**Name:** INTENSET  
**Offset:** 0x01  
**Reset:** 0x00  
**Property:** Write-Protected

This register allows the user to enable an interrupt without doing a read-modify-write operation. Changes in this register will also be reflected in the Interrupt Enable Clear (INTENCLR) register.

	7	6	5	4	3	2	1	0
							DUALE	SINGLEE
Access							R/W	R/W
Reset							0	0

#### Bit 1 – DUALE Dual Bit Error Interrupt Enable Set

Writing a '0' to this bit has no effect.

Writing a '1' to this bit will set the Dual Bit Error Interrupt Enable bit, which enables the Dual Bit Error interrupt.

Value	Description
0	The Dual Bit Error interrupt is disabled.
1	The Dual Bit Error interrupt is enabled.

#### Bit 0 – SINGLEE Single Bit Error Interrupt Enable Set

Writing a '0' to this bit has no effect.

Writing a '1' to this bit will clear the Single Bit Error Interrupt Enable bit, which disables the Single Bit Error interrupt.

Value	Description
0	The Single Bit Error interrupt is disabled.
1	The Single Bit Error interrupt is enabled.

# SAM D5x/E5x Family Data Sheet

## RAMECC – RAM Error Correction Code (ECC)

### 17.8.3 Interrupt Flag Status and Clear

**Name:** INTFLAG  
**Offset:** 0x02  
**Reset:** 0x00

	7	6	5	4	3	2	1	0
							DUALE	SINGLEE
Access							R/W	R/W
Reset							0	0

**Bit 1 – DUALE** Dual Bit ECC Error Interrupt  
 This flag is set on the occurrence of a dual bit ECC error.  
 Writing a '0' to this bit has no effect.  
 Reading the ECCADDR register will clear the Dual Bit Error interrupt flag.

Value	Description
0	No dual bit errors have been received since the last clear.
1	At least one dual bit error has occurred since the last clear.

**Bit 0 – SINGLEE** Single Bit ECC Error Interrupt  
 This flag is set on the occurrence of a single bit ECC error.  
 Writing a '0' to this bit has no effect.  
 Reading the ECCADDR register will clear the Single Bit Error interrupt flag.

Value	Description
0	No errors have been received since the last clear.
1	At least one single bit error has occurred since the last clear.

# SAM D5x/E5x Family Data Sheet

## RAMECC – RAM Error Correction Code (ECC)

### 17.8.4 Status

**Name:** STATUS  
**Offset:** 0x03  
**Reset:** 0x00  
**Property:** Read Only, Write-Protected

Bit	7	6	5	4	3	2	1	0
								ECCDIS
Access								R
Reset								0

#### Bit 0 – ECCDIS ECC Disable

This bit is fuse updated at startup. When enabled, the calculated ECC is written to RAM along with data. ECC correction and detection is enabled for reads.

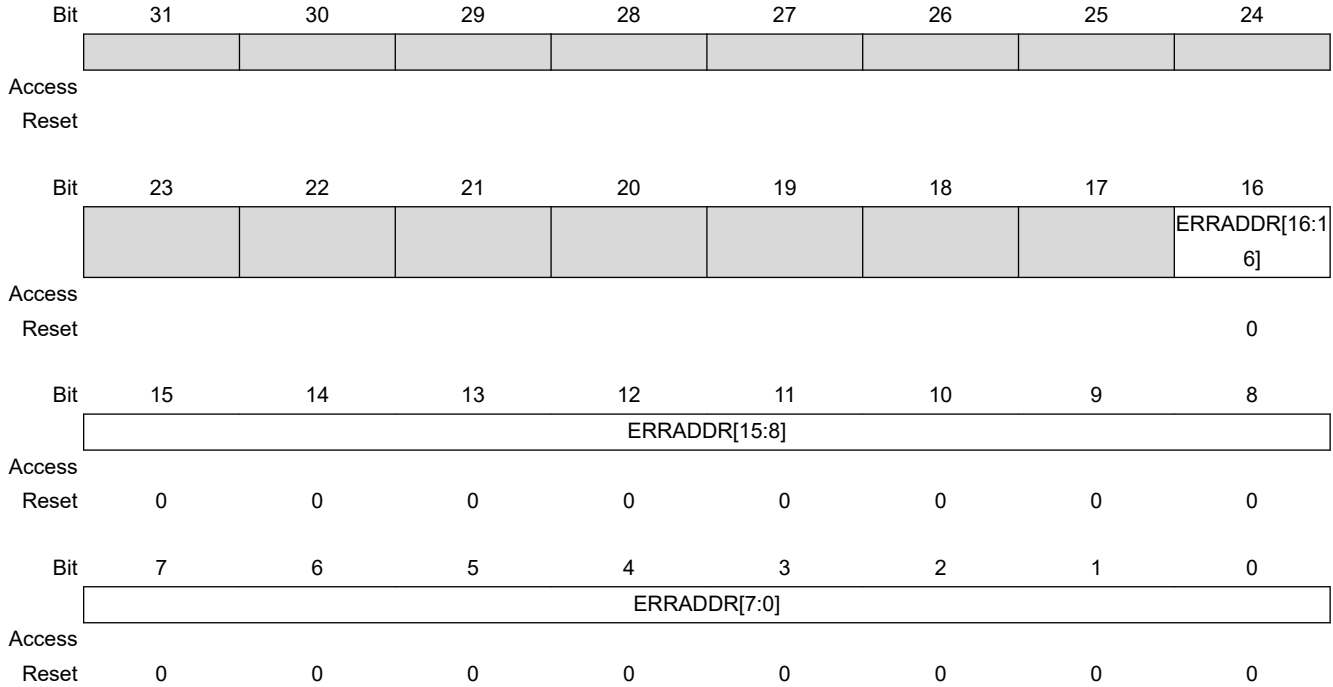
Value	Description
0	ECC detection and correction is enabled.
1	ECC detection and correction is disabled.

# SAM D5x/E5x Family Data Sheet

## RAMECC – RAM Error Correction Code (ECC)

### 17.8.5 Error Address

**Name:** ERRADDR  
**Offset:** 0x04  
**Reset:** 0x00000000  
**Property:** R



**Bits 16:0 – ERRADDR[16:0] ECC Error Address**

The RAM address offset from RAM start that caused an ECC error. If a single bit error is followed by a dual bit error, this register will be updated with the address of the dual bit error, otherwise it stalls on the first error occurrence. This register will read as zero unless INTFLAG.SINGLEEE and/or INTFLAG.DUALE are 1.

# SAM D5x/E5x Family Data Sheet

## RAMECC – RAM Error Correction Code (ECC)

### 17.8.6 Debug Control

**Name:** DBGCTRL  
**Offset:** 0x0F  
**Reset:** 0x00  
**Property:** PAC Write-Protection

	7	6	5	4	3	2	1	0
							ECCELOG	ECCDIS
Access							R/W	R/W
Reset							0	0

**Bit 1 – ECCELOG** ECC Error Log

When DBGCTRL.ECCDIS=0, This bit controls whether ECC errors are logged in the INTFLAG register. When DBGCTRL.ECCDIS=1, this bit has no meaning.

Value	Description
0	ECC errors for debugger reads are not logged.
1	ECC errors for debugger reads are logged if DBGCTRL.ECCDIS=0.

**Bit 0 – ECCDIS** ECC Disable

By default, ECC errors during debugger reads are corrected and logged based on DBGCTRL.ECCELOG. Setting this bit will disable ECC correction and logging.

Value	Description
0	ECC errors are corrected for debugger reads and logged based on DBGCTRL.ECCELOG.
1	ECC errors are masked for debugger reads.

## 18. PM – Power Manager

### Related Links

[39.6.9 Sleep Mode Operation](#)

### 18.1 Overview

The Power Manager (PM) controls the sleep modes and the power domain gating of the device.

Various sleep modes are provided in order to fit power consumption requirements. This enables the PM to stop unused modules in order to save power. In active mode, the CPU is executing application code. When the device enters a sleep mode, program execution is stopped and some modules and clock domains are automatically switched off by the PM according to the sleep mode. The application code decides which sleep mode to enter and when. Interrupts from enabled peripherals and all enabled reset sources can restore the device from a sleep mode to active mode.

The user manually controls which power domains will be turned on and off in standby, hibernate and backup sleep mode.

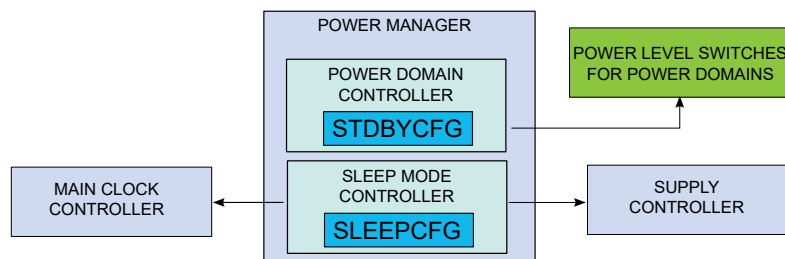
In backup and hibernate mode, the PM allows retaining the state of the I/O lines, preventing I/O lines from toggling during wake-up.

### 18.2 Features

- Power management control
  - Sleep modes: Idle, Hibernate, Standby, Backup, and Off
  - SleepWalking available in standby mode.
  - I/O lines retention in Backup mode

### 18.3 Block Diagram

Figure 18-1. PM Block Diagram



### 18.4 Signal Description

Not applicable.

### 18.5 Product Dependencies

In order to use this peripheral, other parts of the system must be configured correctly, as described below.

### 18.5.1 I/O Lines

Not applicable.

### 18.5.2 Clocks

The PM bus clock (CLK\_PM\_APB) can be enabled and disabled in the Main Clock module. If this clock is disabled, it can only be re-enabled by a system reset.

### 18.5.3 DMA

Not applicable.

### 18.5.4 Interrupts

The interrupt request line is connected to the interrupt controller. Using the PM interrupt requires the interrupt controller to be configured first.

### 18.5.5 Events

Not applicable.

### 18.5.6 Debug Operation

When the CPU is halted in debug mode, the PM continues normal operation. If standby sleep mode is requested by the system while in debug mode, the power domains are not turned off. As a consequence, power measurements while in debug mode are not relevant.

If Hibernate or Backup sleep mode is requested by the system while in debug mode, the core domains are kept on, and the debug modules are kept running to allow the debugger to access internal registers. When exiting the hibernate or backup mode upon a reset condition, the core domains are reset except the debug logic, allowing users to keep using their current debug session.

If OFF sleep mode is requested while in debug mode, the core domains are reset.

Hot plugging in standby mode is supported.

Hot plugging in Hibernate or backup mode or OFF mode is not supported as the DSU module is not powered.

Cold plugging in Hibernate or backup or OFF mode is supported if the external reset duration is superior to the corresponding sleep mode wakeup time (See Electrical characteristic chapter).

*Backup wakeup time is less than 200us in typical case. This value can be higher if voltage scaling in SUPC is enabled. Refers to SUPC for details.*

### 18.5.7 Register Access Protection

Registers with write access can be write-protected optionally by the Peripheral Access Controller (PAC).

PAC write protection is not available for the following registers:

- Interrupt Flag register (INTFLAG). Refer to [18.8.5 INTFLAG](#) for details

Optional PAC write protection is denoted by the "PAC Write-Protection" property in each individual register description.

Write-protection does not apply to accesses through an external debugger.

### 18.5.8 Analog Connections

Not applicable.

## 18.6 Functional Description

### 18.6.1 Terminology

The following is a list of terms used to describe the Power Management features of this microcontroller.

#### 18.6.1.1 Power Domains

Leaving aside the supply domains, such as VDDANA and VDDIO, the device is split into these power domains: PDCORESW, PDBACKUP, PDSYSRAM and PDBKUPRAM.

PDCORESW, PDSYSRAM and PDBKUPRAM are "switchable power domains". In Standby, Hibernate or Backup mode, these power domains can be turned OFF to save leakage consumption according to user configuration.

- PDCORESW: contains the CPU and all the peripherals, except those located in the backup power domain.
- PDBACKUP: contains the backup peripherals: OSC32KCTRL, SUPC, RSTC, RTC and the PM itself.
- PDSYSRAM: contains the system RAM. It can be partially or fully turned OFF in Standby or Hibernate mode according to user configuration.
- PDBKUPRAM: contains the backup RAM. It can be partially or fully turned OFF in Backup mode.

#### 18.6.1.2 Sleep Modes

The device can be set in a sleep mode. In sleep mode, the CPU is stopped and the peripherals are either active or idle, according to the sleep mode depth:

- Idle sleep mode: The CPU is stopped. Synchronous clocks are stopped except when requested. The logic is retained.
- Standby sleep mode: The CPU is stopped as well as the peripherals. The logic is retained, and power domain gating can be used to fully or partially turn off the PDSYSRAM power domain.
- Hibernate sleep mode: PDCORESW power domain is turned OFF. The backup power domain is kept powered to allow few features to run (RTC, 32KHz clock sources, and wake-up from external pins). The PDSYSRAM power domain can be retained according to software configuration.
- Backup sleep mode: Only the backup domain is kept powered to allow few features to run (RTC, 32KHz clock sources, and wake-up from external pins). The PDBKUPRAM power domain can be retained according to software configuration.
- Off sleep mode: The entire device is powered off.

### 18.6.2 Principle of Operation

In active mode, all clock domains and power domains are active, allowing software execution and peripheral operation. The PM Sleep Mode Controller allows to save power by choosing between different sleep modes depending on application requirements, see [18.6.3.3 Sleep Mode Controller](#).

The PM Power Domain Controller allows to reduce the power consumption in standby mode even further.

### 18.6.3 Basic Operation

#### 18.6.3.1 Initialization

After a Power-on Reset (POR), the PM is enabled, the device is in Active mode.

#### 18.6.3.2 Enabling, Disabling and Resetting

The PM is always enabled and can not be reset.



### 18.6.3.3 Sleep Mode Controller

A Sleep mode is entered by executing the Wait For Interrupt instruction (WFI). The Sleep Mode bits in the Sleep Configuration register ([18.8.2 SLEEP\\_CFG.SLEEPMODE](#)) select the level of the sleep mode.

**Note:** A small latency happens between the store instruction and actual writing of the [SLEEP\\_CFG](#) register due to bridges. Software must ensure that the [18.8.2 SLEEP\\_CFG](#) register reads the desired value before issuing a WFI instruction.

**Note:** After power-up, the MAINVREG low power mode takes some time to stabilize. Once stabilized, the INTFLAG.SLEEP\_RDY bit is set. Before entering Standby, Hibernate or Backup mode, software must ensure that the INTFLAG.SLEEP\_RDY bit is set.

**Table 18-1. Sleep Mode Entry and Exit Table**

Mode	Mode Entry	Wake-Up Sources
IDLE	SLEEP_CFG.SLEEPMODE = IDLE	Synchronous <sup>(2)</sup> (APB, AHB), asynchronous <sup>(1)</sup>
STANDBY	SLEEP_CFG.SLEEPMODE = STANDBY	Synchronous <sup>(3)</sup> , asynchronous <sup>(1)</sup>
HIBERNATE	SLEEP_CFG.SLEEPMODE = HIBERNATE	Hibernate reset detected by the RSTC
BACKUP	SLEEP_CFG.SLEEPMODE = BACKUP	Backup reset detected by the RSTC
OFF	SLEEP_CFG.SLEEPMODE = OFF	External Reset

**Note:**

1. Asynchronous: interrupt generated on generic clock, external clock, or external event.
2. Synchronous: interrupt generated on synchronous (APB or AHB) clock.
3. Synchronous interrupt only for peripherals configured to run in standby.

**Note:** The type of wake-up sources (synchronous or asynchronous) is given in each module interrupt section.

The sleep modes (idle, standby, hibernate, backup, and off) and their effect on the clocks activity, the regulator and the NVM state are described in the table and the sections below. Refer to [18.6.3.5 Power Domain Controller](#) for the power domain gating effect.

**Table 18-2. Sleep Mode Overview**

Mode	Main clock	CPU	AHBx and APBx clock	GCLK clocks	Oscillators		Regulator	NVM
					ONDEMAND = 0	ONDEMAND = 1		
Active	Run	Run	Run	Run <sup>(1)</sup>	Run	Run if requested	MAINVREG	active
IDLE	Run	Stop	Stop <sup>(2)</sup>	Run <sup>(1)</sup>	Run	Run if requested	MAINVREG	active
STANDBY	Stop	Stop	Stop <sup>(2)</sup>	Stop <sup>(2)</sup>	Run if requested or RUNSTDBY=1	Run if requested	MAINVREG in low power mode	Ultra Low power
HIBERNATE	Stop	Stop	Stop	Stop	Stop	Stop	MAINVREG in low power mode	Ultra Low power+
BACKUP	Stop	Stop	Stop	Stop	Stop	Stop	Backup regulator (LPVREG)	OFF
OFF	Stop	Stop	Stop	OFF	OFF	OFF	OFF	OFF

**Note:**

1. Running if requested by peripheral during SleepWalking
2. Running during SleepWalking

**18.6.3.3.1 IDLE Mode**

IDLE mode allows power optimization with the fastest wake-up time.

The CPU is stopped, and peripherals are still working. As in Active mode, the AHBx and APBx clocks for peripheral are still provided if requested. As the main clock source is still running, wake-up time is very fast.

- Entering Idle mode: The Idle mode is entered by executing the WFI instruction. Additionally, if the SLEEPONEXIT bit in the Cortex System Control register (SCR) is set, the Idle mode will be entered when the CPU exits the lowest priority ISR (Interrupt Service Routine, refer to the ARM Cortex documentation for details). This mechanism can be useful for applications that only require the processor to run when an interrupt occurs. Before entering the Idle mode, the user must select the Idle Sleep mode in the Sleep Configuration register (SLEEPCFG.SLEEPMODE=IDLE).
- Exiting Idle mode: The processor wakes the system up when it detects any non-masked interrupt with sufficient priority to cause exception entry. The system goes back to the Active mode. The CPU and affected modules are restarted.

GCLK clocks, regulators and RAM are not affected by the Idle Sleep mode and operate in normal mode.

**18.6.3.3.2 STANDBY Mode**

The STANDBY mode is the lowest power configuration while keeping the state of the logic and the content of the RAM.

In this mode, all clocks are stopped except those configured to be running sleepwalking tasks. The clocks can also be active on request or at all times, depending on their on-demand and run-in-standby settings. Either synchronous (CLK\_APBx or CLK\_AHBx) or generic (GCLK\_x) clocks or both can be involved in sleepwalking tasks. This is the case when for example the SERCOM RUNSTDBY bit is written to '1'.

- Entering STANDBY mode: This mode is entered by executing the WFI instruction after writing the Sleep Mode bit in the Sleep Configuration register ([18.8.2 SLEEPCFG.SLEEPMODE=STANDBY](#)). The SLEEPONEXIT feature is also available as in IDLE mode.
- Exiting STANDBY mode: Any peripheral able to generate an asynchronous interrupt can wake up the system. For example, a peripheral running on a GCLK clock can trigger an interrupt. When the enabled asynchronous wake-up event occurs and the system is woken up, the device will either execute the interrupt service routine or continue the normal program execution according to the Priority Mask Register (PRIMASK) configuration of the CPU.

Refer to the section about the Power Domain Controller for the RAM state.

The regulator operates in low-power mode by default and switches automatically to the normal mode in case of a sleepwalking task requiring more power. It returns automatically to low power mode when the sleepwalking task is completed.

**Related Links**

[18.6.3.5 Power Domain Controller](#)

**18.6.3.3.3 Hibernate and Backup Mode**

Hibernate and Backup mode allow achieving the lowest power consumption aside from OFF. The device is entirely powered off except for the backup domain. All peripherals in backup domain are allowed to run, for example, the RTC can be clocked by a 32.768 kHz oscillator. All PM registers are retained except INTENCLR, INTENSET, INTFLAG, and SLEEPCFG registers.

- Entering Hibernate or Backup mode: This mode is entered by executing the WFI instruction after selecting the Hibernate or Backup mode by writing the Sleep Mode bits in the Sleep Configuration register (18.8.2 SLEEP\_CFG.SLEEPMODE=HIBERNATE or =BACKUP).
- Exiting Hibernate or Backup mode: is triggered when a Hibernate or Backup Reset is detected by the Reset Controller (RSTC).  
**Note:** In Hibernate mode, the MAINVREG (in low-power mode) regulator is used to allow powering the PDRAM power domain which can be fully retained according to software configuration.  
**Note:** In Backup mode, the backup regulator (LPVREG) is used, unless VREG.RUNBKUP = 1. When VREG.RUNBKUP is set, the Main regulator is used in backup mode. The PDBKUPRAM power domain can be fully retained according to software configuration. Refer to the 18.6.3.5 Power Domain Controller for the RAM state.

#### 18.6.3.3.4 OFF Mode

In Off mode, the device is entirely powered-off.

- Entering Off mode: This mode is entered by selecting the Off mode in the Sleep Configuration register by writing the Sleep Mode bits (SLEEP\_CFG.SLEEPMODE=OFF), and subsequent execution of the WFI instruction.
- Exiting Off mode: This mode is left by pulling the  $\overline{\text{RESET}}$  pin low, or when a power Reset is done.

#### 18.6.3.4 I/O Lines Retention in HIBERNATE or BACKUP Mode

When entering HIBERNATE or BACKUP mode, the PORT is powered off but the pin configuration is retained. When the device exits the HIBERNATE or BACKUP mode, the I/O line configuration can either be released or stretched, based on the I/O Retention bit in the Control A register (CTRLA.IORET).

- If IORET=0 when exiting HIBERNATE or BACKUP mode, the I/O lines configuration is released and driven by the reset value of the PORT.
- If the IORET=1 when exiting HIBERNATE or BACKUP mode, the configuration of the I/O lines is retained until the IORET bit is written to 0. It allows the I/O lines to be retained until the application has programmed the PORT.

#### 18.6.3.5 Power Domain Controller

The Power Domain Controller provides several ways of how power domains are handled while the device is in standby, hibernate or backup mode:

- Standby mode:  
When entering standby mode, the PDSYSRAM power domain can be either fully or partially retained or be fully off according to STDBYCFG.RAMCFG bits. When running sleepwalking task, PDSYSRAM power domain is active whatever the STDBYCFG.RAMCFG bits are.
- Hibernate mode:  
When entering hibernate mode, the PDCORESW power domain is off. As in standby mode, the PDSYSRAM power domain can be selectively turned ON or OFF by using the HIBCFG.RAMCFG bits. PDBKUPRAM power domain can be either fully or partially retained or be fully off according to HIBCFG.BRAMCFG bits. If partial option is selected, only the lowest 4KBytes section is retained
- Backup mode:  
When entering backup mode, the PDCORESW and PDSYSRAM power domains are off. PDBKUPRAM is still active. As in hibernate mode, PDBKUPRAM power domain can be either fully or partially retained or be fully off according to BKUPCFG.BRAMCFG bits.
- OFF mode:  
When entering OFF mode, all the power domains are off.

The table below illustrates the PDRAM state:

# SAM D5x/E5x Family Data Sheet

## PM – Power Manager

**Table 18-3. Sleep Mode versus PDSYSRAM Power Domain State Overview**

Sleep Mode	STDBYCFG .RAMCFG	HIBCFG.RA MCFG	Power Domain State		
			PDCORESW	PDBACKUP	PDSYSRAM
Active	N/A	N/A	active	active	active
Idle	N/A	N/A	active	active	active
Standby with sleepwalking	N/A	N/A	active	active	active
Standby - case 1	RET	N/A	active	active	retained
Standby - case 2	PARTIAL	N/A	active	active	32K retained
Standby - case 3	OFF	N/A	active	active	off
Hibernate - case 1	N/A	RET	off	active	retained
Hibernate - case 2	N/A	PARTIAL	off	active	32K retained
Hibernate - case 3	N/A	OFF	off	active	off
Backup	N/A	N/A	off	active	off
Off	N/A	N/A	off	off	off

The table below illustrates the PDBKUPRAM state:

**Table 18-4. Sleep Mode versus PDBKUPRAM Power Domain State Overview**

Sleep Mode	HIBCFG.BR AMCFG	BKUPCFG. BRAMCFG	Power Domain State		
			PDCORESW	PDBACKUP	PDBKUPRAM
Active	N/A	N/A	active	active	active
Idle	N/A	N/A	active	active	active
Standby	N/A	N/A	active	active	retained
Hibernate - case 1	RET	N/A	off	active	retained
Hibernate - case 2	PARTIAL	N/A	off	active	4KB retained
Hibernate - case 3	OFF	N/A	off	active	off
Backup	N/A	RET	off	active	retained
Backup	N/A	PARTIAL	off	active	4KB retained
Backup	N/A	OFF	off	active	off

# SAM D5x/E5x Family Data Sheet

## PM – Power Manager

.....continued					
Sleep Mode	HIBCFG.BR AMCFG	BKUPCFG. BRAMCFG	Power Domain State		
			PDCORESW	PDBACKUP	PDBKUPRAM
Off	N/A	N/A	off	off	off

### 18.6.3.6 Regulators, RAMs, and NVM State in Sleep Mode

By default, in standby sleep mode and backup sleep mode, the RAMs, NVM, and regulators are automatically set in low-power mode in order to reduce power consumption:

- The RAM is in low-power mode if the device is in standby mode.
- Non-Volatile Memory - the NVM is automatically set in low power mode in these conditions:
  - When the device is in standby sleep mode and the NVM is not accessed. This behavior can be changed by software by configuring the SLEEPFRM bit group of the CTRLB register in the NVMCTRL peripheral.
  - When the device is in idle sleep mode and the NVM is not accessed. This behavior can be changed by software by configuring the SLEEPFRM bit group of the CTRLB register in the NVMCTRL peripheral.
- Regulators: by default, in standby sleep mode, the PM analyzes the device activity to use either the main or the low-power voltage regulator to supply the VDDCORE.

GCLK clocks, regulators and RAM are not affected in idle sleep mode and will operate as normal.

**Table 18-5. Regulators, RAMs, and NVM state in Sleep Mode**

Sleep Mode	SRAM Mode	NVM	Regulators		
			VDDCORE		VDDBU
			main	ULP	
Active	normal	normal	on	on	on
Idle	auto <sup>(1)</sup>	on	on	on	on
Standby - case 1	normal	auto <sup>(1)</sup>	auto <sup>(2)</sup>	on	on
Standby - case 2	low power	low power	auto <sup>(2)</sup>	on	on
Standby - case 3	low power	low power	auto <sup>(2)</sup>	on	on
Standby - case 4	low power	low power	off	on	on
Backup	off	off	off	off	on
OFF	off	off	off	off	off

**Note:**

1. auto: by default, NVM is in low-power mode if not accessed.
2. auto: by default, the main voltage regulator is on if GCLK, APBx, or AHBx clock is running during SleepWalking.

**Related Links**

[18.6.3.5 Power Domain Controller](#)

### 18.6.4 Advanced Features

#### 18.6.4.1 SleepWalking

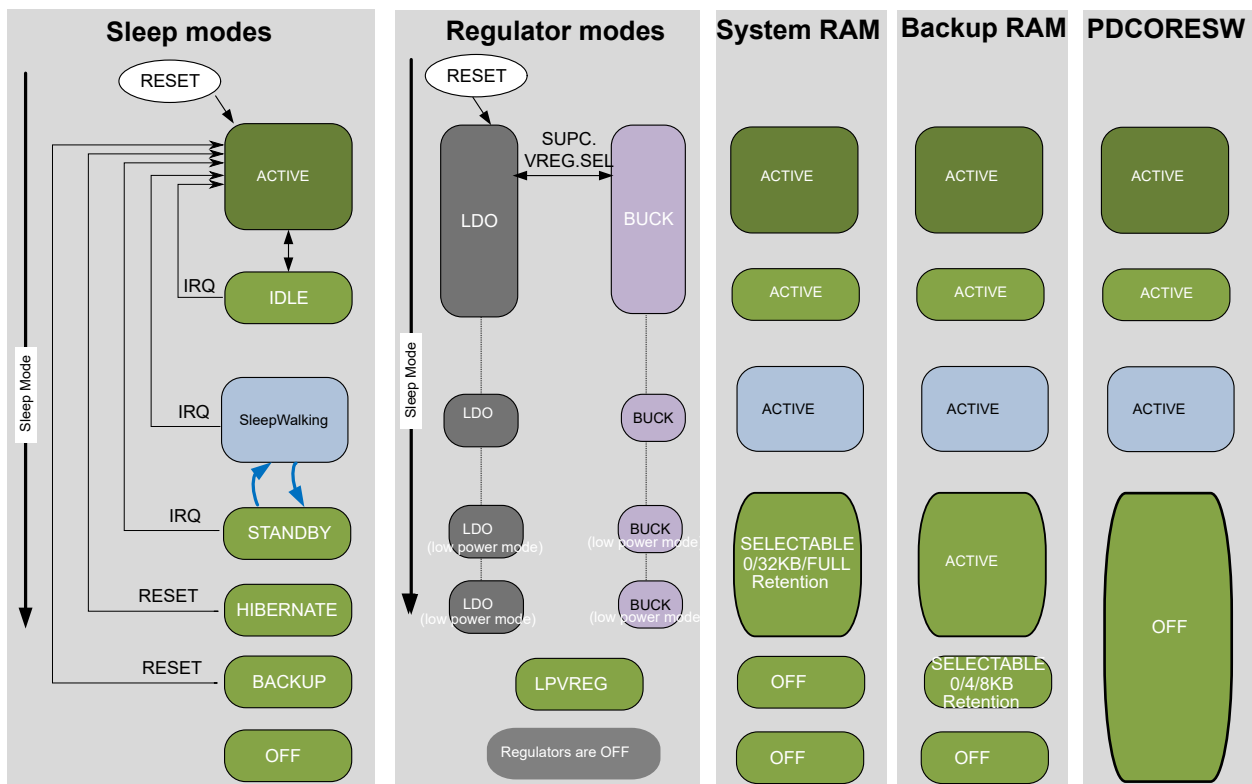
SleepWalking is the capability for a device to temporarily wake up clocks for a peripheral to perform a task without waking up the CPU from STANDBY sleep mode. At the end of the sleepwalking task, the device can either be woken up by an interrupt (from a peripheral involved in SleepWalking) or enter again into STANDBY sleep mode. In this device, SleepWalking is supported only on GCLK clocks by using the on-demand clock principle of the clock sources.

In standby, when SleepWalking is ongoing:

- All the power domains are turned ON including PDRAM power domain.
- The MAINVREG regulator used to execute the sleepwalking task is the selected regulator used in active mode (LDO or Buck converter). Low power mode of the MAINVREG is not activated during sleepwalking.

These are illustrated in the figure below.

**Figure 18-2. Operating Conditions and SleepWalking**



#### 18.6.4.2 Wake-Up Time

As shown in the figure below, total wake-up time depends on:

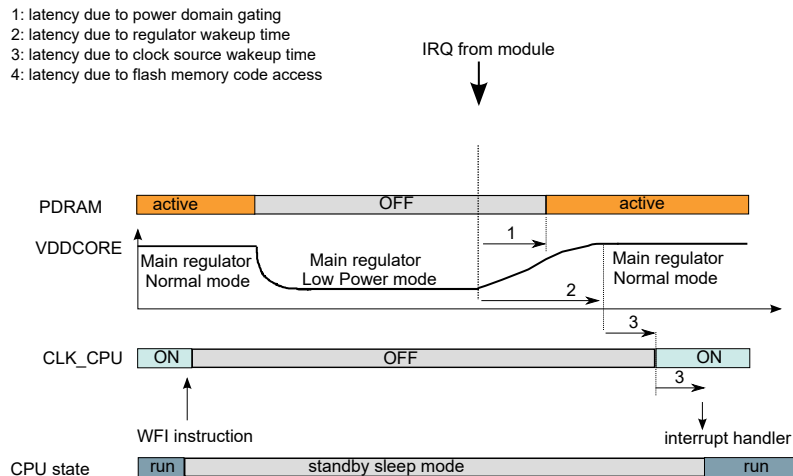
- Latency due to Power Domain Gating:  
Usually, wake-up time is measured with the assumption that the power domains are already in active state. When using Power Domain Gating, changing a power domain from OFF to active state will take a certain time, refer to Electrical Characteristics. If all power domains were already in active state in standby sleep mode, this latency is zero.
- Latency due to Regulator effect:

As example, if the device is in standby sleep mode using the main voltage regulator (MAINVREG) in low power mode, the voltage level is lower than the one used in active mode. When the device wakes up, it takes a certain amount of time for the main regulator to transition to the voltage level corresponding to active mode, causing additional wake-up time.

- Latency due to the CPU clock source wake-up time.
- Latency due to the NVM memory access.

**Note:** NVM and MAINVREG latencies can be reduced by setting the Fast Wake-Up bits in the Standby Configuration register (STDBYCFG.FASTWKUP).

**Figure 18-3. Total Wake-up Time from Standby Sleep Mode**



### Related Links

[18.6.1.1 Power Domains](#)

### 18.6.5 DMA Operation

Not applicable.

### 18.6.6 Interrupts

The peripheral has the following interrupt sources:

- Sleep Mode Entry Ready (SLEEPREDY): indicates that the device is ready to enter standby, hibernate or backup sleep mode. This interrupt is a synchronous wake-up source.

Each interrupt source has an interrupt flag associated with it. The interrupt flag in the Interrupt Flag Status and Clear (INTFLAG) register is set when the interrupt condition occurs. Each interrupt can be individually enabled by writing a '1' to the corresponding bit in the Interrupt Enable Set (INTENSET) register, and disabled by writing a '1' to the corresponding bit in the Interrupt Enable Clear (INTENCLR) register.

An interrupt request is generated when the interrupt flag is set and the corresponding interrupt is enabled. The interrupt request remains active until the interrupt flag is cleared, the interrupt is disabled or the peripheral is reset.

An interrupt flag is cleared by writing a '1' to the corresponding bit in the INTFLAG register. Each peripheral can have one interrupt request line per interrupt source or one common interrupt request line for all the interrupt sources. If the peripheral has one common interrupt request line for all the interrupt sources, the user must read the INTFLAG register to determine which interrupt condition is present.

### 18.6.7 Events

Not applicable.

### 18.6.8 Sleep Mode Operation

The Power Manager is always active.



### 18.7 Register Summary

Offset	Name	Bit Pos.							
0x00	<a href="#">CTRLA</a>	7:0						IORET	
0x01	<a href="#">SLEEPCFG</a>	7:0						SLEEPMODE[2:0]	
0x02	Reserved								
...									
0x03									
0x04	<a href="#">INTENCLR</a>	7:0							SLEEPRDY
0x05	<a href="#">INTENSET</a>	7:0							SLEEPRDY
0x06	<a href="#">INTFLAG</a>	7:0							SLEEPRDY
0x07	Reserved								
0x08	<a href="#">STDBYCFG</a>	7:0			FASTWKUP[1:0]				RAMCFG[1:0]
0x09	<a href="#">HIBCFG</a>	7:0					BRAMCFG[1:0]		RAMCFG[1:0]
0x0A	<a href="#">BKUPCFG</a>	7:0							BRAMCFG[1:0]
0x0B	Reserved								
0x0C	<a href="#">PWSAKDLY</a>	7:0	IGNACK					DLYVAL[6:0]	

### 18.8 Register Description

Registers can be 8, 16, or 32 bits wide. Atomic 8-, 16- and 32-bit accesses are supported. In addition, the 8-bit quarters and 16-bit halves of a 32-bit register, and the 8-bit halves of a 16-bit register can be accessed directly.

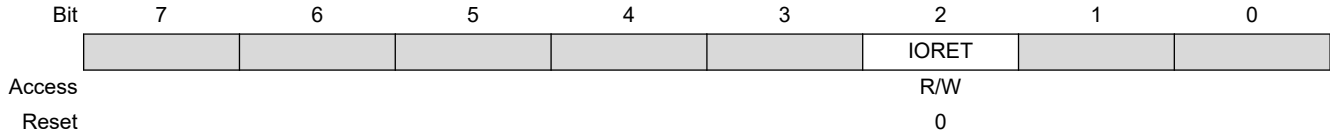
Some registers are optionally write-protected by the Peripheral Access Controller (PAC). Optional PAC write protection is denoted by the "PAC Write-Protection" property in each individual register description. For details, refer to Register Access Protection section.

#### Related Links

[18.5.7 Register Access Protection](#)

### 18.8.1 Control A

**Name:** CTRLA  
**Offset:** 0x00  
**Reset:** 0x00  
**Property:** PAC Write-Protection



#### Bit 2 – IORET I/O Retention

**Note:** This bit is not reset by a hibernate or backup reset. When the IORET feature is used, the debugger access to the chip will not be allowed until the IORET bit is cleared after waking up from hibernate or backup sleep. When the IORET is set in active mode, the PORT can still be controlled by peripherals and the PORT registers. It is only when the device wakes up from hibernate or backup sleep mode that the IORET= 1 will prevent the PORT from being controlled by the peripherals or PORT registers. POR and BOD33 resets can clear the IORET bit.

Value	Description
0	After waking up from Hibernate or Backup mode, I/O lines are not held.
1	After waking up from Hibernate or Backup mode, I/O lines are held until IORET is written to 0.

### 18.8.2 Sleep Configuration

**Name:** SLEEPCFG  
**Offset:** 0x01  
**Reset:** 0x02  
**Property:** PAC Write-Protection

	7		6		5		4		3		2		1		0
	SLEEPMODE[2:0]														
Access												R/W	R/W	R/W	
Reset												0	0	0	

#### Bits 2:0 – SLEEPMODE[2:0] Sleep Mode

**Note:** A small latency happens between the store instruction and actual writing of the SLEEPCFG register due to bridges. Software has to make sure the SLEEPCFG register reads the wanted value before issuing WFI instruction.

Value	Name	Definition
0x0	Reserved	-
0x1	Reserved	-
0x2	IDLE	CPU, AHBx, and APBx clocks are OFF
0x3	Reserved	Reserved
0x4	STANDBY	All Clocks are OFF
0x5	HIBERNATE	Backup domain is ON as well as some PDRAMs
0x6	BACKUP	Only Backup domain is powered ON
0x7	OFF	All power domains are powered OFF

### 18.8.3 Interrupt Enable Clear

**Name:** INTENCLR  
**Offset:** 0x04  
**Reset:** 0x00  
**Property:** PAC Write-Protection

This register allows the user to disable an interrupt without doing a read-modify-write operation. Changes in this register will also be reflected in the Interrupt Enable Set (INTENSET) register.

Bit	7	6	5	4	3	2	1	0
								SLEEPRDY
Access								W
Reset								0

**Bit 0 – SLEEPRDY** Sleep Mode Entry Ready Interrupt Enable

Writing a '0' to this bit has no effect.

Writing a '1' to this bit will clear the Sleep Mode Entry Ready Interrupt Enable bit and the corresponding interrupt request.

Value	Description
0	The Sleep Mode Entry Ready interrupt is disabled.
1	The Sleep Mode Entry Ready interrupt is enabled and will generate an interrupt request when the Sleep Mode Entry Ready Interrupt Flag is set.

### 18.8.4 Interrupt Enable Set

**Name:** INTENSET  
**Offset:** 0x05  
**Reset:** 0x00  
**Property:** PAC Write-Protection

This register allows the user to enable an interrupt without doing a read-modify-write operation. Changes in this register will also be reflected in the Interrupt Enable Clear (INTENCLR) register.

	7	6	5	4	3	2	1	0
								SLEEPRDY
Access								R/W
Reset								0

**Bit 0 – SLEEPRDY** Sleep Mode Entry Ready Interrupt Enable

Writing a '0' to this bit has no effect.

Writing a '1' to this bit will set the Sleep Mode Entry Ready Interrupt Enable bit and enable the Sleep Mode Entry Ready interrupt.

Value	Description
0	The Sleep Mode Entry Ready interrupt is disabled.
1	The Sleep Mode Entry Ready interrupt is enabled.

### 18.8.5 Interrupt Flag Status and Clear

**Name:** INTFLAG  
**Offset:** 0x06  
**Reset:** 0x00  
**Property:** –

Bit	7	6	5	4	3	2	1	0
								SLEEP RDY
Access								R/W
Reset								0

#### Bit 0 – SLEEP RDY Sleep Mode Entry Ready

This flag is set when the main very low power mode is ready and will generate an interrupt if [INTENCLR/SET.SLEEP RDY](#) is '1'. See [this Note](#) for details.

Writing a '1' to this bit has no effect.

Writing a '1' to this bit clears the Performance Ready interrupt flag.

### 18.8.6 Hibernate Configuration

**Name:** HIBCFG  
**Offset:** 0x09  
**Reset:** 0x00  
**Property:** PAC Write-Protection

	7	6	5	4	3	2	1	0
					BRAMCFG[1:0]		RAMCFG[1:0]	
Access					R/W	R/W	R/W	R/W
Reset					0	0	0	0

#### Bits 3:2 – BRAMCFG[1:0] Backup RAM Configuration

Value	Name	Description
0x0	RET	In hibernate mode, all the backup RAM is retained.
0x1	PARTIAL	In hibernate mode, only the first 4Kbytes of the backup RAM is retained.
0x2	OFF	In hibernate mode, all the backup RAM is turned OFF.
0x3	Reserved	Reserved.

#### Bits 1:0 – RAMCFG[1:0] RAM Configuration

Value	Name	Description
0x0	RET	In hibernate mode, all the system RAM is retained.
0x1	PARTIAL	In hibernate mode, only the first 32Kbytes of the system RAM is retained.
0x2	OFF	In hibernate mode, all the system RAM is turned OFF.
0x3	Reserved	Reserved.

### 18.8.7 Standby Configuration

**Name:** STDBYCFG  
**Offset:** 0x08  
**Reset:** 0x00  
**Property:** PAC Write-Protection

	7	6	5	4	3	2	1	0
			FASTWKUP[1:0]				RAMCFG[1:0]	
Access			R/W	R/W			R/W	R/W
Reset			0	0			0	0

#### Bits 5:4 – FASTWKUP[1:0] Fast Wakeup

Value	Name	Description
0x0	NO	Fast Wakeup is disabled.
0x1	NVM	Fast Wakeup is enabled on NVM.
0x2	MAINVREG	Fast Wakeup is enabled on the main voltage regulator (MAINVREG).
0x3	BOTH	Fast Wakeup is enabled on both NVM and MAINVREG..

#### Bits 1:0 – RAMCFG[1:0] RAM Configuration

Value	Name	Description
0x0	RET	In standby mode, all the system RAM is retained.
0x1	PARTIAL	In standby mode, only the first 32Kbytes of the system RAM is retained.
0x2	OFF	In standby mode, all the system RAM is turned OFF.
0x3	Reserved	Reserved.



# SAM D5x/E5x Family Data Sheet

## PM – Power Manager

### 18.8.8 Backup Configuration

**Name:** BKUPCFG  
**Offset:** 0x0A  
**Reset:** 0x00  
**Property:** PAC Write-Protection

Bit	7	6	5	4	3	2	1	0
							BRAMCFG[1:0]	
Access							R/W	R/W
Reset							0	0

#### Bits 1:0 – BRAMCFG[1:0] Backup RAM Configuration

Value	Name	Description
0x0	RET	In backup mode, all the backup RAM is retained.
0x1	PARTIAL	In backup mode, only the first 4Kbytes of the backup RAM is retained.
0x2	OFF	In backup mode, all the backup RAM is turned OFF.
0x3	Reserved	Reserved.

### 18.8.9 Global Status

**Name:** PWSAKDLY  
**Offset:** 0xC [ID-00000a2f]  
**Reset:** 0x00  
**Property:** –

	Bit	7	6	5	4	3	2	1	0
		IGNACK	DLYVAL[6:0]						
Access		R	R	R	R	R	R	R	R
Reset		0	0	0	0	0	0	0	0

#### Bit 7 – IGNACK Ignore Acknowledge signal

Value	Description
0	Power Switch acknowledge signal is taken into account when entering/exiting retention mode. According to the DLYVAL field, a supplementary delay is also added (from 0 to 127 digital ring oscillator period).
1	Power Switch acknowledge signal is ignored when entering/exiting retention mode, and is replaced by a overflow counter signal clocked on internal digital ring oscillator. The overflow counter is programmable by using the DLYVAL field.

#### Bits 6:0 – DLYVAL[6:0] Delay value

Value of the counter overflow. See the IGNACK bit description to get more details.

## 19. SUPC – Supply Controller

### 19.1 Overview

The Supply Controller (SUPC) manages the voltage reference, power supply and supply monitoring of the device. It is also able to control two output pins.

The SUPC controls the voltage regulators for the core (VDDCORE) and backup (VDDBU) domains. It sets the voltage regulators according to the sleep modes, or the user configuration. In active mode, the voltage regulators can be selected on the fly between LDO (low-dropout) type regulator or Buck converter.

The SUPC supports connection of a battery backup to the VBAT power pin. It includes functionality that enables automatic power switching between main power and battery backup power. This ensures power to the backup domain when the main battery or power source is unavailable.

The SUPC embeds two Brown-Out Detectors. BOD33 monitors the voltage applied to the device (VDD or VBAT) and BOD12 monitors the internal voltage to the core (VDDCORE). The BOD33 can monitor the supply voltage continuously (continuous mode) or periodically (sampling mode), in normal or low power mode.

The SUPC generates also a selectable reference voltage and a voltage dependent on the temperature which can be used by analog modules like the ADC.

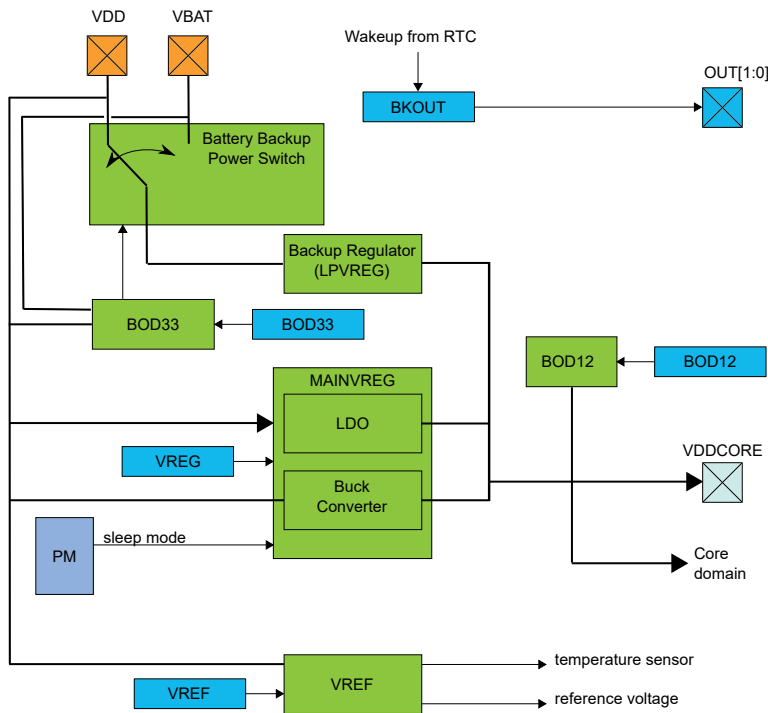
### 19.2 Features

- Voltage Regulator System
  - Main voltage regulator: LDO or Buck Converter in Active, Standby or Hibernate mode (MAINVREG)
  - Low-Power voltage regulator in Backup mode (LPVREG)
  - Controlled VDDCORE voltage slope when changing VDDCORE
- Battery Backup Power Switch
  - Automatic switching from main power to battery backup power
    - Automatic entry to backup mode when switched to battery backup power
  - Automatic switching from battery backup power to main power
    - Automatic exit from backup mode when switched back to main power
    - Stay in backup mode when switched back to main power
- Voltage Reference System
  - Reference voltage for ADC and DAC
  - Temperature sensor
- 3.3V Brown-Out Detector (BOD33)
  - Programmable threshold
  - Threshold value loaded from NVM User Row at startup
  - Triggers resets, interrupts, or Battery Backup Power Switch. Action loaded from NVM User Row
  - Operating modes:
    - Continuous mode

- Low power and sampled mode for low power applications with programmable sample frequency
  - Hysteresis value from Flash User Calibration
  - Monitor VDD or VBAT
- 1.2V Brown-Out Detector (BOD12)
- Output pins
  - Pin toggling on RTC event

### 19.3 Block Diagram

Figure 19-1. SUPC Block Diagram



### 19.4 Signal Description

Signal Name	Type	Description
OUT[1:0]	Digital Output	SUPC Outputs

One signal can be mapped on several pins.

#### Related Links

[6. I/O Multiplexing and Considerations](#)

### 19.5 Product Dependencies

In order to use this peripheral, other parts of the system must be configured correctly, as described below.

### 19.5.1 I/O Lines

I/O lines are configured by SUPC when the SUPC output (signal OUT) is enabled. The I/O lines need no user configuration.

### 19.5.2 Power Management

The SUPC can operate in all sleep modes except backup sleep mode. BOD33 and Battery backup Power Switch can operate in backup mode.

#### Related Links

[18. PM – Power Manager](#)

### 19.5.3 Clocks

The SUPC bus clock (CLK\_SUPC\_APB) can be enabled and disabled in the Main Clock module.

A 32KHz clock, asynchronous to the user interface clock (CLK\_SUPC\_APB), is required to run BOD33 and in sampled mode. Due to this asynchronicity, writing to certain registers will require synchronization between the clock domains. Refer to [19.6.7 Synchronization](#) for further details.

#### Related Links

[29. OSC32KCTRL – 32KHz Oscillators Controller](#)

[15.6.2.6 Peripheral Clock Masking](#)

### 19.5.4 DMA

Not applicable.

### 19.5.5 Interrupts

The interrupt request lines are connected to the interrupt controller. Using the SUPC interrupts requires the interrupt controller to be configured first.

#### Related Links

[10.2 Nested Vector Interrupt Controller](#)

### 19.5.6 Events

Not applicable.

### 19.5.7 Debug Operation

When the CPU is halted in debug mode, the SUPC continues normal operation. If the SUPC is configured in a way that requires it to be periodically serviced by the CPU through interrupts or similar, improper operation or data loss may result during debugging.

If a cold plug-in is detected by the system, BOD33 and BOD12 will use the factory calibration setting instead of the user calibration. In hot plug-in, the BODs resets keep running.

### 19.5.8 Register Access Protection

Registers with write access can be write-protected optionally by the Peripheral Access Controller (PAC).

**Note:** Not all registers with write access can be write-protected.

PAC write protection is not available for the following registers:

- Interrupt Flag Status and Clear register (INTFLAG)

Optional PAC write protection is denoted by the "PAC Write-Protection" property in each individual register description.

### Related Links

[27. PAC - Peripheral Access Controller](#)

### 19.5.9 Analog Connections

Not applicable.

## 19.6 Functional Description

### 19.6.1 Voltage Regulator System Operation

#### 19.6.1.1 Enabling, Disabling, and Resetting

The LDO main voltage regulator is enabled after a power-reset. The main voltage regulator output supply level is automatically defined by the sleep mode selected in the Power Manager module.

#### 19.6.1.2 Initialization

After a power-reset, the LDO voltage regulator supplying VDDCORE is enabled.

#### 19.6.1.3 Selecting a Voltage Regulator

In Active mode, the type of the main voltage regulator supplying VDDCORE can be switched on the fly. The two alternatives are a LDO regulator and a Buck converter.

The main voltage regulator switching sequences are as follows:

- The user changes the value of the Voltage Regulator Selection bit in the Voltage Regulator System Control register (VREG.SEL)
- The start of the switching sequence is indicated by clearing the Voltage Regulator Ready bit in the STATUS register (STATUS.VREGRDY=0)
- Once the switching sequence is completed, STATUS.VREGRDY will read '1'

The Voltage Regulator Ready (VREGRDY) interrupt can also be used to detect a zero-to-one transition of the STATUS.VREGRDY bit.

#### 19.6.1.4 Voltage Scaling Control

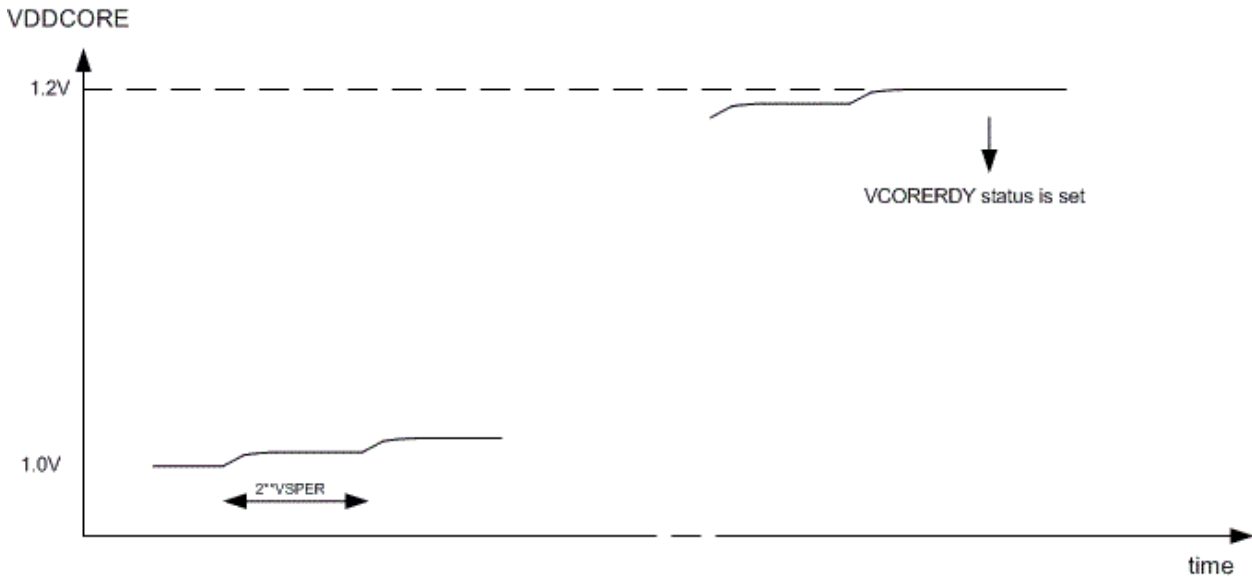
The VDDCORE supply will change under certain circumstances:

- When a Sleep mode (Standby, Hibernate, Backup) is entered or exited
- When a sleepwalking task is requested in Standby Sleep mode

To prevent high peak current on the main power supply and to have a smooth transition of VDDCORE, the Voltage Scaling Period field in VREG (VREG.VSPER) can be controlled: VDDCORE is changed by a typical 5 mV of the selected voltage scaling period ( $2^{VSPER}$ ) \* T until the target voltage is reached.

The smooth transition of VDDCORE is enabled/disabled by setting/clearing the Voltage Scaling Enable bit in VREG (VREG.VSEN).

The following waveform shows an example of exiting the Standby Sleep mode.



The STATUS.VCORERDY bit is set to '1' as soon as the VDDCORE voltage has reached the target voltage. During voltage transition, STATUS.VCORERDY will read '0'. The Voltage Ready interrupt (VCORERDY) can be used to detect a 0-to-1 transition of STATUS.VCORERDY, see also [19.5.5 Interrupts](#).

When entering the Standby, Hibernate, or Backup Sleep mode, and when no sleepwalking task is requested, the VDDCORE Voltage scaling control is not used.

### 19.6.1.5 Sleep Mode Operation

In Standby and Hibernate mode, the main voltage regulator (MAINVREG) operates in low power mode. In backup mode, the low-power voltage regulator (LPVREG) is used to supply VDDCORE.

### 19.6.2 Voltage Reference System Operation

The reference voltages are generated by a functional block DETREF inside of the SUPC. DETREF is providing a fixed-voltage source, BANDGAP=1.1V, and a variable voltage, VREF.

#### 19.6.2.1 Initialization

The voltage reference output and the temperature sensor are disabled after any Reset.

#### 19.6.2.2 Enabling, Disabling, and Resetting

The voltage reference output is enabled/disabled by setting/clearing the Voltage Reference Output Enable bit in the Voltage Reference register (VREF.VREFOE).

The temperature sensor is enabled/disabled by setting/clearing the Temperature Sensor Enable bit in the Voltage Reference register (VREF.TSEN).

**Note:** When VREF.ONDEMAND=0, it is not recommended to enable both voltage reference output and temperature sensor at the same time - only the voltage reference output will be present at both ADC inputs.

#### 19.6.2.3 Selecting a Voltage Reference

The Voltage Reference Selection bit field in the VREF register (VREF.SEL) selects the voltage of VREF to be applied to analog modules, e.g. the ADC.

### 19.6.2.4 Sleep Mode Operation

The Voltage Reference output and the Temperature Sensor output behavior during sleep mode can be configured using the Run in Standby bit and the On Demand bit in the Voltage Reference register (VREF.RUNSTDBY, VREF.ONDEMAND), see the following table:

**Table 19-1. VREF Sleep Mode Operation**

VREF.ONDEMAND	VREF.RUNSTDBY	Voltage Reference Sleep behavior
-	-	Disable
0	0	Always run in all sleep modes <i>except</i> standby sleep mode
0	1	Always run in all sleep modes <i>including</i> standby sleep mode
1	0	Only run if requested by the ADC, in all sleep modes <i>except</i> standby sleep mode
1	1	Only run if requested by the ADC, in all sleep modes <i>including</i> standby sleep mode

### 19.6.3 Battery Backup Power Switch

#### 19.6.3.1 Initialization

The Battery Backup Power Switch (BBPS) is disabled at power-up, and the backup domain is supplied by main power.

#### 19.6.3.2 Automatic Battery Backup Power Switch

The supply of the backup domain can be switched automatically to VBAT supply pin by the Battery Backup Power Switch when the BOD33 detects that the VDD supply is below the VDD threshold level (BOD33.LEVEL). It is switched back to VDD supply pin when the BOD33 detects that VDD is above the VDD threshold level (BOD33.LEVEL).

To enable this feature, the following configuration is required: BOD33.ACTION=BKUP.

#### 19.6.3.3 Sleep Mode Operation

The Battery Backup Power Switch is not stopped in any sleep mode.

##### 19.6.3.3.1 Entering Battery Backup Mode

Entering backup mode can be triggered by either:

- Wait-for-interrupt (WFI) instruction.
- BOD33 detection: When the BOD33 detects loss of Main Power, the Backup Domain will be powered by battery and the device will enter the backup mode. For this trigger, the following register configuration is required: BOD33.ACTION=BKUP.

#### Related Links

[18. PM – Power Manager](#)

##### 19.6.3.3.2 Leaving Battery Backup Mode

Leaving backup mode is triggered by the RSTC when a Backup Mode Exit condition occurs. See RSTC module for details.

- BOD33 exit condition: When the BOD33 detects Main Power is restored and BOD33.ACTION=BKUP:
  - When BBPS.WAKEEN=1, the device will leave backup mode and wake up.



- When BBPS.WAKEEN=0, the backup domain will be powered by Main Power, but the device will stay in backup mode.
- For other exit condition (RTC): The device is kept in battery-powered backup mode until Main Power is restored to supply the device. Then, the backup domain will be powered by Main Power.

### 19.6.4 Output Pins

The SUPC can drive two outputs. By writing a '1' to the corresponding Output Enable bit in the Backup Output Control register (BKOUT.EN), the OUTx pin is driven by the SUPC.

The OUT pin can be set by writing a '1' to the corresponding Set Output bit in the Backup Output Control register (BKOUT.SETx).

The OUT pin can be cleared by writing a '1' to the corresponding CLR bit (BKOUT.CLRx).

If a RTC Toggle Enable bit is written to '1' (BKOUT.RTCTGLx), the corresponding OUTx pin will toggle when an RTC event occurs.

### 19.6.5 Brown-Out Detectors

#### 19.6.5.1 Initialization

Before a Brown-Out Detector (BOD33) is enabled, it must be configured, as outlined by the following:

- Set the BOD threshold level (BOD33.LEVEL)
- Set the configuration in Active, Standby, Hibernate, and Backup modes (BOD33.ACTION, BOD33.STDBYCFG, BOD33.BKUP, BOD33.RUNHIB, and BOD33.RUNBKUP)
- Set the prescaling value if the BOD will run in sampling mode (BOD33.PSEL)
- Set the action and hysteresis (BOD33.ACTION and BOD33.HYST)

The BOD33 register is Enable-Protected, meaning that they can only be written when the BOD is disabled (BOD33.ENABLE=0 and STATUS.B33SRDY=0). As long as the Enable bit is '1', any writes to Enable-Protected registers will be discarded, and an APB error will be generated. The Enable bits are not Enable-Protected.

#### 19.6.5.2 Enabling, Disabling, and Resetting

After power or user reset, the BOD33 and BOD12 register values are loaded from the NVM User Page.

The BOD33 is enabled by writing a '1' to the Enable bit in the BOD control register (BOD33.ENABLE). The BOD33 is disabled by writing a '0' to the BOD33.ENABLE.

#### Related Links

[18. PM – Power Manager](#)

[9.4 NVM User Page Mapping](#)

#### 19.6.5.3 3.3V Brown-Out Detector (BOD33)

The 3.3V Brown-Out Detector (BOD33) is able to monitor either the VDD or the VBAT supply and compares the voltage with the brown-out threshold levels.

In all mode except battery backup mode, the BOD33 compares the VDD voltage with the brown-out threshold level. This level is set in the BOD33 Level field in the BOD33 register (BOD33.LEVEL). When VDD crosses below the brown-out threshold level, the BOD33 can generate either an interrupt, or a Reset, or an Automatic Battery Backup Power Switch, depending on the BOD33 Action bit field (BOD33.ACTION).

In battery backup mode, the BOD33 monitors both the VBAT and VDD supplies alternatively. When VBAT crosses below the backup brown-out threshold level (BOD33.VBATLEVEL), the BOD33 generates a

Power Supply Reset. When VDD crosses above the brown-out threshold level (BOD33.LEVEL), the device will leave battery backup mode and will wakeup from backup mode if the BBPS.WAKEEN bit is set.

The BOD33 detection status can be read from the BOD33 Detection bit in the Status register (STATUS.BOD33DET).

At start-up or at Power-On Reset (POR), the BOD33 register values are loaded from the NVM User Row.

### Related Links

[9.4 NVM User Page Mapping](#)

#### 19.6.5.3.1 BOD33 Sampling Mode

The Sampling Mode is a low-power mode where the BOD33 is being repeatedly enabled on a sampling clock's ticks. The BOD33 will monitor the supply voltage (VDD or VBAT) for a short period of time and then go to a low-power disabled state until the next sampling clock tick.

Sampling mode is enabled in Backup or Hibernate mode by writing to the BOD33 bits (BOD33.BKUPCFG = 1 or BOD33.HIBCFG = 1). The frequency of the clock ticks ( $F_{clk\text{sampling}}$ ) is controlled by the Prescaler Select bit groups in the BOD33 register (BOD33.PSEL).

$$F_{clk\text{sampling}} = \frac{F_{clk\text{prescaler}}}{2^{(PSEL+1)}}$$

The prescaler signal ( $F_{clk\text{prescaler}}$ ) is a 32 kHz clock, output by the 32 kHz Ultra Low-Power Oscillator OSCULP32K.

**Note:** If (BOD33.PSEL) is 0, sampling mode is disabled.

As the sampling clock is different from the APB clock domain, synchronization among the clocks is necessary. See [19.6.7 Synchronization](#) for additional information.

### Related Links

[9.4 NVM User Page Mapping](#)

#### 19.6.5.3.2 BOD33 Low Power Mode

BOD33 Low Power mode is automatically enabled in Backup or Hibernate sleep mode.

BOD33 Low Power mode can be enabled in Standby sleep mode by writing to '1' the BOD33.STDBYCFG bit.

### Related Links

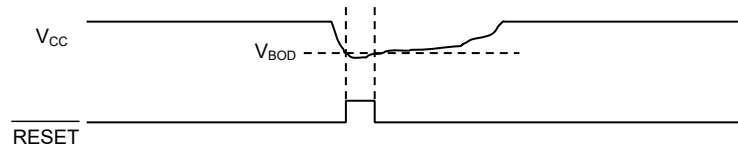
[9.4 NVM User Page Mapping](#)

#### 19.6.5.3.3 BOD33 Hysteresis

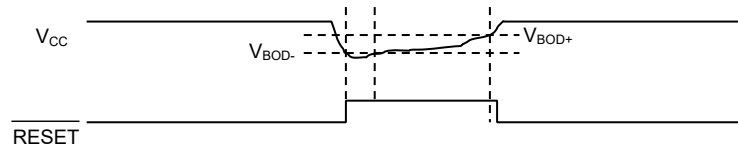
A hysteresis on the trigger threshold of a BOD will reduce the sensitivity to ripples on the monitored voltage: instead of switching  $\overline{\text{RESET}}$  at each crossing of  $V_{\text{BOD}}$ , the thresholds for switching  $\overline{\text{RESET}}$  on and off are separated ( $V_{\text{BOD-}}$  and  $V_{\text{BOD+}}$ , respectively).

### Figure 19-2. BOD Hysteresis Principle

Hysteresis OFF:



Hysteresis ON:



Enabling the BOD33 hysteresis by writing the Hysteresis bit field in the BOD33 register (BOD33.HYST) to a non-null value will add hysteresis to the BOD33 threshold level.

The hysteresis functionality can be used in Sampling Mode.

### Related Links

[9.4 NVM User Page Mapping](#)

#### 19.6.5.3.4 Standby Sleep Mode

The BOD33 can be used in standby mode if the BOD is enabled and the Run in Standby bit is written to '1' (BOD33.RUNSTDBY).

It is set in Low Power mode if the BOD33.STDBYCFG bit is written to '1'.

### Related Links

[9.4 NVM User Page Mapping](#)

#### 19.6.5.3.5 Backup and Hibernate sleep Modes

To enable the BOD33 in Backup or Hibernate sleep mode, the Run in Backup or Hibernate sleep mode bits in the BOD33 register (BOD33.RUNBKUP, BOD33.RUNHIB) must be written to '1'. The BOD33 is automatically set in BOD33 Ultra Low-Power mode. Additionally, the BOD33 will operate in Sampling mode if the BOD33.PSEL bit is non-null. In this state, the voltage monitored by BOD33 is always the supply of the backup domain, i.e. VDD or VBAT.

### Related Links

[9.4 NVM User Page Mapping](#)

#### 19.6.5.4 1.2V Brown-Out Detector (BOD12)

The BOD12 is calibrated in production and its calibration configuration is stored in the NVM User Row. This configuration must not be changed to assure the correct behavior of the BOD12. The BOD12 generates a reset when 1.2V crosses below the preset brown-out level. The BOD12 is always disabled in Standby, Hibernate, and Backup Sleep modes.

### Related Links

[9.4 NVM User Page Mapping](#)

#### 19.6.6 Interrupts

The SUPC has the following interrupt sources, which are either synchronous or asynchronous wake-up sources:

- VDDCORE Voltage Ready (VCORERDY), asynchronous

- Voltage Regulator Ready (VREGRDY) asynchronous
- BOD33 Ready (BOD33RDY), synchronous
- BOD33 Detection (BOD33DET), asynchronous
- BOD33 Synchronization Ready (B33SRDY), synchronous

Each interrupt source has an interrupt flag associated with it. The interrupt flag in the Interrupt Flag Status and Clear register (INTFLAG) is set when the interrupt condition occurs.

Each interrupt can be individually enabled by writing a '1' to the corresponding bit in the Interrupt Enable Set register (INTENSET), and disabled by writing a '1' to the corresponding bit in the Interrupt Enable Clear register (INTENCLR).

An interrupt request is generated when the interrupt flag is set and the corresponding interrupt is enabled. The interrupt request remains active until either the interrupt flag is cleared, the interrupt is disabled, or the SUPC is reset. See the INTFLAG register for details on how to clear interrupt flags. The user must read the INTFLAG register to determine which interrupt condition is present.

**Note:** Interrupts must be globally enabled for interrupt requests to be generated.

### 19.6.7 Synchronization

The prescaler counters that are used to trigger brown-out detections operate asynchronously from the peripheral bus. As a consequence, the BOD33 Enable bit (BOD33.ENABLE) need synchronization when written.

The Write-Synchronization of the Enable bit is triggered by writing a '1' to the Enable bit of the BOD33 Control register. The Synchronization Ready bit (STATUS.B33SRDY) in the STATUS register will be cleared when the Write-Synchronization starts, and set again when the Write-Synchronization is complete. Writing to the same register while the Write-Synchronization is ongoing (STATUS.B33SRDY is '0') will generate a PAC error without stalling the APB bus.

# SAM D5x/E5x Family Data Sheet

## SUPC – Supply Controller

### 19.7 Register Summary

Offset	Name	Bit Pos.									
0x00	INTENCLR	7:0						B33SRDY	BOD33DET	BOD33RDY	
		15:8						VCORERDY		VREGRDY	
		23:16									
		31:24									
0x04	INTENSET	7:0						B33SRDY	BOD33DET	BOD33RDY	
		15:8						VCORERDY		VREGRDY	
		23:16									
		31:24									
0x08	INTFLAG	7:0						B33SRDY	BOD33DET	BOD33RDY	
		15:8						VCORERDY		VREGRDY	
		23:16									
		31:24									
0x0C	STATUS	7:0						B33SRDY	BOD33DET	BOD33RDY	
		15:8						VCORERDY		VREGRDY	
		23:16									
		31:24									
0x10	BOD33	7:0	RUNBKUP	RUNHIB	RUNSTDBY	STDBYCFG	ACTION[1:0]	ENABLE			
		15:8		PSEL[2:0]			HYST[3:0]				
		23:16	LEVEL[7:0]								
		31:24	VBATLEVEL[7:0]								
0x14 ... 0x17	Reserved										
0x18	VREG	7:0	RUNBKUP					SEL	ENABLE		
		15:8									
		23:16								VSEN	
		31:24						VSPER[2:0]			
0x1C	VREF	7:0	ONDEMAND	RUNSTDBY			TSEL	VREFOE	TSEN		
		15:8									
		23:16					SEL[3:0]				
		31:24									
0x20	BBPS	7:0						WAKEEN		CONF	
		15:8									
		23:16									
		31:24									
0x24	BKOUT	7:0							EN1	EN0	
		15:8							CLR1	CLR0	
		23:16							SET1	SET0	
		31:24							RTCTGL1	RTCTGL0	
0x28	BKIN	7:0							BKIN1	BKIN0	
		15:8									
		23:16									
		31:24									

### 19.8 Register Description

Registers can be 8, 16, or 32 bits wide. Atomic 8-, 16-, and 32-bit accesses are supported. In addition, the 8-bit quarters and 16-bit halves of a 32-bit register, and the 8-bit halves of a 16-bit register can be accessed directly.

Some registers are optionally write-protected by the Peripheral Access Controller (PAC). PAC Write-protection is denoted by the "PAC Write-Protection" property in each individual register description. Refer to [19.5.8 Register Access Protection](#) for details.

Some registers require synchronization when read and/or written. Synchronization is denoted by the "Write-Synchronized" or the "Read-Synchronized" property in each individual register description. Refer to [19.6.7 Synchronization](#) for details.

### 19.8.1 Interrupt Enable Clear

**Name:** INTENCLR  
**Offset:** 0x00  
**Reset:** 0x00000000  
**Property:** PAC Write-Protection

This register allows the user to disable an interrupt without doing a read-modify-write operation. Changes in this register will also be reflected in the Interrupt Enable Set register (INTENSET).

Bit	31	30	29	28	27	26	25	24	
Access									
Reset									
Bit	23	22	21	20	19	18	17	16	
Access									
Reset									
Bit	15	14	13	12	11	10	9	8	
						VCORERDY			VREGRDY
Access						R/W			R/W
Reset						0			0
Bit	7	6	5	4	3	2	1	0	
						B33SRDY	BOD33DET	BOD33RDY	
Access						R/W	R/W	R/W	
Reset						0	0	0	

#### Bit 10 – VCORERDY VDDCORE Voltage Ready Interrupt Enable

Writing a '0' to this bit has no effect.

Writing a '1' to this bit will clear the VDDCORE Ready Interrupt Enable bit, which disables the VDDCORE Ready interrupt.

Value	Description
0	The VDDCORE Ready interrupt is disabled.
1	The VDDCORE Ready interrupt is enabled and an interrupt request will be generated when the VCORERDY Interrupt Flag is set.

#### Bit 8 – VREGRDY Voltage Regulator Ready Interrupt Enable

Writing a '0' to this bit has no effect.

Writing a '1' to this bit will clear the Voltage Regulator Ready Interrupt Enable bit, which disables the Voltage Regulator Ready interrupt.

Value	Description
0	The Voltage Regulator Ready interrupt is disabled.
1	The Voltage Regulator Ready interrupt is enabled and an interrupt request will be generated when the Voltage Regulator Ready Interrupt Flag is set.

#### Bit 2 – B33SRDY BOD33 Synchronization Ready Interrupt Enable

Writing a '0' to this bit has no effect.

# SAM D5x/E5x Family Data Sheet

## SUPC – Supply Controller

Writing a '1' to this bit will clear the BOD33 Synchronization Ready Interrupt Enable bit, which disables the BOD33 Synchronization Ready interrupt.

Value	Description
0	The BOD33 Synchronization Ready interrupt is disabled.
1	The BOD33 Synchronization Ready interrupt is enabled, and an interrupt request will be generated when the BOD33 Synchronization Ready Interrupt flag is set.

### Bit 1 – BOD33DET BOD33 Detection Interrupt Enable

Writing a '0' to this bit has no effect.

Writing a '1' to this bit will clear the BOD33 Detection Interrupt Enable bit, which disables the BOD33 Detection interrupt.

Value	Description
0	The BOD33 Detection interrupt is disabled.
1	The BOD33 Detection interrupt is enabled, and an interrupt request will be generated when the BOD33 Detection Interrupt flag is set.

### Bit 0 – BOD33RDY BOD33 Ready Interrupt Enable

Writing a '0' to this bit has no effect.

Writing a '1' to this bit will clear the BOD33 Ready Interrupt Enable bit, which disables the BOD33 Ready interrupt.

Value	Description
0	The BOD33 Ready interrupt is disabled.
1	The BOD33 Ready interrupt is enabled, and an interrupt request will be generated when the BOD33 Ready Interrupt flag is set.



### 19.8.2 Interrupt Enable Set

**Name:** INTENSET  
**Offset:** 0x04  
**Reset:** 0x00000000  
**Property:** PAC Write-Protection

This register allows the user to disable an interrupt without doing a read-modify-write operation. Changes in this register will also be reflected in the Interrupt Enable Clear register (INTENCLR).

Bit	31	30	29	28	27	26	25	24	
Access									
Reset									
Bit	23	22	21	20	19	18	17	16	
Access									
Reset									
Bit	15	14	13	12	11	10	9	8	
						VCORERDY			VREGRDY
Access						R/W			R/W
Reset						0			0
Bit	7	6	5	4	3	2	1	0	
						B33SRDY	BOD33DET	BOD33RDY	
Access						R/W	R/W	R/W	
Reset						0	0	0	

**Bit 10 – VCORERDY** VDDCORE Voltage Ready Interrupt Enable

Writing a '0' to this bit has no effect.

Writing a '1' to this bit will set the VDDCORE Ready Interrupt Enable bit, which enables the VDDCORE Ready interrupt.

Value	Description
0	The VDDCORE Ready interrupt is disabled.
1	The VDDCORE Ready interrupt is enabled and an interrupt request will be generated when the VCORERDY Interrupt Flag is set.

**Bit 8 – VREGRDY** Voltage Regulator Ready Interrupt Enable

Writing a '0' to this bit has no effect.

Writing a '1' to this bit will set the Voltage Regulator Ready Interrupt Enable bit, which enables the Voltage Regulator Ready interrupt.

Value	Description
0	The Voltage Regulator Ready interrupt is disabled.
1	The Voltage Regulator Ready interrupt is enabled and an interrupt request will be generated when the Voltage Regulator Ready Interrupt Flag is set.

**Bit 2 – B33SRDY** BOD33 Synchronization Ready Interrupt Enable

Writing a '0' to this bit has no effect.

# SAM D5x/E5x Family Data Sheet

## SUPC – Supply Controller

Writing a '1' to this bit will set the BOD33 Synchronization Ready Interrupt Enable bit, which enables the BOD33 Synchronization Ready interrupt.

Value	Description
0	The BOD33 Synchronization Ready interrupt is disabled.
1	The BOD33 Synchronization Ready interrupt is enabled, and an interrupt request will be generated when the BOD33 Synchronization Ready Interrupt flag is set.

### Bit 1 – BOD33DET BOD33 Detection Interrupt Enable

Writing a '0' to this bit has no effect.

Writing a '1' to this bit will set the BOD33 Detection Interrupt Enable bit, which enables the BOD33 Detection interrupt.

Value	Description
0	The BOD33 Detection interrupt is disabled.
1	The BOD33 Detection interrupt is enabled, and an interrupt request will be generated when the BOD33 Detection Interrupt flag is set.

### Bit 0 – BOD33RDY BOD33 Ready Interrupt Enable

Writing a '0' to this bit has no effect.

Writing a '1' to this bit will set the BOD33 Ready Interrupt Enable bit, which enables the BOD33 Ready interrupt.

Value	Description
0	The BOD33 Ready interrupt is disabled.
1	The BOD33 Ready interrupt is enabled, and an interrupt request will be generated when the BOD33 Ready Interrupt flag is set.

### 19.8.3 Interrupt Flag Status and Clear

**Name:** INTFLAG  
**Offset:** 0x08  
**Reset:** 0x0000010X  
**Property:** -

In the reset value: X= determined from NVM User Row (0xX=0bx00y)

Bit	31	30	29	28	27	26	25	24	
Access									
Reset									
Bit	23	22	21	20	19	18	17	16	
Access									
Reset									
Bit	15	14	13	12	11	10	9	8	
						VCORERDY			VREGRDY
Access						R/W			R/W
Reset						0			0
Bit	7	6	5	4	3	2	1	0	
						B33SRDY	BOD33DET	BOD33RDY	
Access						R/W	R/W	R/W	
Reset						0	0	y	

**Bit 10 – VCORERDY** VDDCORE Voltage Ready

This flag is cleared by writing a '1' to it.

This flag is set on a zero-to-one transition of the VDDCORE Ready bit in the Status register (STATUS.VCORERDY) and will generate an interrupt request if INTENSET.VCORERDY=1.

Writing a '0' to this bit has no effect.

Writing a '1' to this bit clears the VCORERDY interrupt flag.

**Bit 8 – VREGRDY** Voltage Regulator Ready

This flag is cleared by writing a '1' to it.

This flag is set on a zero-to-one transition of the Voltage Regulator Ready bit in the Status register (STATUS.VREGRDY) and will generate an interrupt request if INTENSET.VREGRDY=1.

Writing a '0' to this bit has no effect.

Writing a '1' to this bit clears the VREGRDY interrupt flag.

**Bit 2 – B33SRDY** BOD33 Synchronization Ready

This flag is cleared by writing a '1' to it.

This flag is set on a zero-to-one transition of the BOD33 Synchronization Ready bit in the Status register (STATUS.B33SRDY) and will generate an interrupt request if INTENSET.B33SRDY=1.

Writing a '0' to this bit has no effect.

Writing a '1' to this bit clears the BOD33 Synchronization Ready interrupt flag.

**Bit 1 – BOD33DET** BOD33 Detection

This flag is cleared by writing a '1' to it.

This flag is set on a zero-to-one transition of the BOD33 Detection bit in the Status register (STATUS.BOD33DET) and will generate an interrupt request if INTENSET.BOD33DET=1.

Writing a '0' to this bit has no effect.

Writing a '1' to this bit clears the BOD33 Detection interrupt flag.

**Bit 0 – BOD33RDY** BOD33 Ready

This flag is cleared by writing a '1' to it.

This flag is set on a zero-to-one transition of the BOD33 Ready bit in the Status register (STATUS.BOD33RDY) and will generate an interrupt request if INTENSET.BOD33RDY=1.

Writing a '0' to this bit has no effect.

Writing a '1' to this bit clears the BOD33 Ready interrupt flag.

The BOD33 can be enabled.

**Related Links**

[9.4 NVM User Page Mapping](#)

# SAM D5x/E5x Family Data Sheet

## SUPC – Supply Controller

### 19.8.4 Status

**Name:** STATUS  
**Offset:** 0x0C  
**Reset:** Determined from NVM User Row  
**Property:** -

	31	30	29	28	27	26	25	24
	[Bit Field Diagram]							
Access								
Reset								
	23	22	21	20	19	18	17	16
	[Bit Field Diagram]							
Access								
Reset								
	15	14	13	12	11	10	9	8
	[Bit Field Diagram]							
Access								
Reset								
	7	6	5	4	3	2	1	0
	[Bit Field Diagram]							
Access								
Reset								

#### Bit 10 – VCORERDY VDDCORE Voltage Ready

Value	Description
0	the VDDCORE voltage is not as expected.
1	the VDDCORE voltage is the target voltage.

#### Bit 8 – VREGRDY Voltage Regulator Ready

Value	Description
0	The selected voltage regulator in VREG.SEL is not ready.
1	The voltage regulator selected in VREG.SEL is ready and the core domain is supplied by this voltage regulator.

#### Bit 2 – B33SRDY BOD33 Synchronization Ready

Value	Description
0	BOD33 synchronization is ongoing.
1	BOD33 synchronization is complete.

#### Bit 1 – BOD33DET BOD33 Detection

Value	Description
0	No BOD33 detection.
1	BOD33 has detected that the I/O power supply is going below the BOD33 reference value.

# SAM D5x/E5x Family Data Sheet

## SUPC – Supply Controller

---

**Bit 0 – BOD33RDY** BOD33 Ready

The BOD33 can be enabled at start-up from NVM User Row.

Value	Description
0	BOD33 is not ready.
1	BOD33 is ready.

**Related Links**

[9.4 NVM User Page Mapping](#)

### 19.8.5 3.3V Brown-Out Detector (BOD33) Control

**Name:** BOD33  
**Offset:** 0x10  
**Reset:** Determined from NVM User Row  
**Property:** Write-Synchronized, PAC Write-Protection

	Bit	31	30	29	28	27	26	25	24
		VBATLEVEL[7:0]							
Access		R/W	R/W	R/W	R/W	R/W	R/W	R/W	R/W
Reset		0	0	0	0	0	0	0	0
	Bit	23	22	21	20	19	18	17	16
		LEVEL[7:0]							
Access		R/W	R/W	R/W	R/W	R/W	R/W	R/W	R/W
Reset		0	0	x	x	x	x	x	x
	Bit	15	14	13	12	11	10	9	8
			PSEL[2:0]				HYST[3:0]		
Access			R/W	R/W	R/W	R/W	R/W	R/W	R/W
Reset			0	0	0	x	x	x	x
	Bit	7	6	5	4	3	2	1	0
		RUNBKUP	RUNHIB	RUNSTDBY	STDBYCFG	ACTION[1:0]		ENABLE	
Access		R/W	R/W	R/W	R/W	R/W	R/W	R/W	
Reset		0	0	0	0	y	y	z	

**Bits 31:24 – VBATLEVEL[7:0]** BOD33 Threshold Level on VBAT

This field sets the triggering voltage threshold for the BOD33 when the BOD33 monitors VBAT in battery backup sleep mode.

This field is not synchronized.

**Bits 23:16 – LEVEL[7:0]** BOD33 Threshold Level on VDD

This field sets the triggering voltage threshold for the BOD33 when the BOD33 monitors VDD. If an hysteresis value is programmed (BOD33.HYST), this field corresponds to the lower threshold ( $V_{BOD-}$ ). These bits are loaded from NVM User Row at start-up.

This field is not synchronized.

The  $V_{BOD-}$  input voltage can be calculated as follows:  $V_{BOD-} = 1.5 + LEVEL[7:0] \times Level\_Step$

And the upper threshold ( $V_{BOD+}$ ) is then:  $V_{BOD+} = V_{BOD-} + N \times HYST\_STEP$ , With  $N=0$  to 15 according to  $HYST[3:0]$  value and  $HYST\_STEP = Level\_Step$ , (refer to Bits 11:8 –  $HYST[3:0]$ : BOD33 Hysteresis voltage value on VDD).

At the upper side of  $Level[7:0]$  values depending on the Hysteresis value chosen with  $HYST[3:0]$ , the  $V_{BOD+}$  level reaches an overflow, e.g., for  $HYST[3:0] = 0d2$  the hysteresis is  $2 \times Level\_Step = 12$  mV up to position 253 and position 254 to 255 above must not be used.

**Bits 14:12 – PSEL[2:0]** Prescaler Select

Selects the prescaler divide-by output for the BOD33 sampling mode available in hibernate, backup or battery backup mode. The input clock comes from the OSCULP32K 32KHz output.

# SAM D5x/E5x Family Data Sheet

## SUPC – Supply Controller

Value	Name	Description
0x0	NODIV	Not divided: Sampling mode is OFF.
0x1	DIV4	Divide clock by 4
0x2	DIV8	Divide clock by 8
0x3	DIV16	Divide clock by 16
0x4	DIV32	Divide clock by 32
0x5	DIV64	Divide clock by 64
0x6	DIV128	Divide clock by 128
0x7	DIV256	Divide clock by 256

### Bits 11:8 – HYST[3:0] BOD33 Hysteresis Voltage Value on $V_{DD}$

This field sets the hysteresis voltage value related to "BOD33 Threshold Level on VDD" field when the BOD33 monitors VDD.

These bits are loaded from NVM User Row at start-up.

This field is not synchronized.

Value	Description
0	No hysteresis.
N	Hysteresis value is set to $N \cdot \text{HYST\_STEP}$ . See the Electrical Characteristics section for the HYST_STEP voltage level.

### Bit 7 – RUNBKUP BOD33 Configuration in Backup Sleep Mode

This field is not synchronized.

Value	Description
0	In backup sleep mode, the BOD33 is disabled.
1	In backup sleep mode, the BOD33 is enabled and configured in sampling mode.

### Bit 6 – RUNHIB BOD33 Configuration in Hibernate Sleep Mode

This field is not synchronized.

Value	Description
0	In hibernate sleep mode, the BOD33 is disabled.
1	In hibernate sleep mode, the BOD33 is enabled and configured in sampling mode.

### Bit 5 – RUNSTDBY Run in Standby

This bit is not synchronized.

Value	Description
0	In standby sleep mode, the BOD33 is disabled.
1	In standby sleep mode, the BOD33 is enabled.

### Bit 4 – STDBYCFG BOD33 Configuration in Standby Sleep Mode

If the RUNSTDBY bit is set to '1', the STDBYCFG bit sets the BOD33 configuration in standby sleep mode.

This field is not synchronized.

Value	Description
0	In standby sleep mode, the BOD33 is enabled and configured in normal mode.
1	In standby sleep mode, the BOD33 is enabled and configured in low power mode.

### Bits 3:2 – ACTION[1:0] BOD33 Action

These bits are used to select the BOD33 action when the supply voltage crosses below the BOD33 threshold.



# SAM D5x/E5x Family Data Sheet

## SUPC – Supply Controller

These bits are loaded from NVM User Row at start-up.  
This field is not synchronized.

Value	Name	Description
0x0	NONE	No action
0x1	RESET	The BOD33 generates a reset
0x2	INT	The BOD33 generates an interrupt
0x3	BKUP-	The BOD33 puts the device in battery backup sleep mode.

### Bit 1 – ENABLE Enable

This bit is loaded from NVM User Row at start-up.  
This bit is not enable-protected.

Value	Description
0	BOD33 is disabled.
1	BOD33 is enabled.

### Related Links

[9.4 NVM User Page Mapping](#)

# SAM D5x/E5x Family Data Sheet

## SUPC – Supply Controller

### 19.8.6 Voltage Regulator System (VREG) Control

**Name:** VREG  
**Offset:** 0x18  
**Reset:** 0x00000002  
**Property:** PAC Write-Protection

	31	30	29	28	27	26	25	24	
							VSPER[2:0]		
Access							R/W	R/W	R/W
Reset							0	0	0
	23	22	21	20	19	18	17	16	
								VSEN	
Access								R/W	
Reset								0	
	15	14	13	12	11	10	9	8	
Access									
Reset									
	7	6	5	4	3	2	1	0	
	RUNBKUP					SEL	ENABLE		
Access	R/W					R/W	R/W		
Reset	0					0	1		

#### Bits 26:24 – VSPER[2:0] Voltage Scaling Period

This bitfield defines the time between the voltage steps when the VDDCORE voltage scaling is enabled. The time is  $(2^{VSPER}) * T$ , where T is an internal period (typ 250 ns).

#### Bit 16 – VSEN Voltage Scaling Enable

Value	Description
0	The voltage scaling is disabled.
1	The voltage scaling is enabled.

#### Bit 7 – RUNBKUP Run in Backup

This bit controls how the main voltage regulator behaves in backup sleep mode.

Value	Description
0	The main voltage regulator is halted during backup sleep mode.
1	The main voltage regulator is not stopped during backup sleep mode.

#### Bit 2 – SEL Voltage Regulator Selection

This bit is loaded from NVM User Row at start-up. Refer to *NVM User Row Mapping* section for more details.

Value	Description
0	The main voltage regulator is a LDO voltage regulator.
1	The main voltage regulator is a buck converter.

**Bit 1 – ENABLE** Must be set to 1.

### Related Links

[9.4 NVM User Page Mapping](#)

# SAM D5x/E5x Family Data Sheet

## SUPC – Supply Controller

### 19.8.7 Voltage References System (VREF) Control

**Name:** VREF  
**Offset:** 0x1C  
**Reset:** 0x00000000  
**Property:** PAC Write-Protection

	Bit	31	30	29	28	27	26	25	24
		[Greyed out bits 31-24]							
Access									
Reset									
	Bit	23	22	21	20	19	18	17	16
						SEL[3:0]			
Access						R/W	R/W	R/W	R/W
Reset						0	0	0	0
	Bit	15	14	13	12	11	10	9	8
		[Greyed out bits 15-8]							
Access									
Reset									
	Bit	7	6	5	4	3	2	1	0
		ONDEMAND	RUNSTDBY			TSEL	VREFOE	TSEN	
Access		R/W	R/W			R/W	R/W	R/W	
Reset		0	0			0	0	0	

**Bits 19:16 – SEL[3:0]** Voltage Reference Selection  
 These bits select the Voltage Reference for the ADC/DAC.

Value	Name	Description
0x0	1V0	1.0V voltage reference typical value
0x1	1V1	1.1V voltage reference typical value
0x2	1V2	1.2V voltage reference typical value
0x3	1V25	1.25V voltage reference typical value
0x4	2V0	2.0V voltage reference typical value
0x5	2V2	2.2V voltage reference typical value
0x6	2V4	2.4V voltage reference typical value
0x7	2V5	2.5V voltage reference typical value
Others		Reserved

**Bit 7 – ONDEMAND** On Demand Control  
 The On Demand operation mode allows to enable or disable the voltage reference depending on peripheral requests.

Value	Description
0	The voltage reference is always on, if enabled.
1	The voltage reference is enabled when a peripheral is requesting it. The voltage reference is disabled if no peripheral is requesting it.

# SAM D5x/E5x Family Data Sheet

## SUPC – Supply Controller

### Bit 6 – RUNSTDBY Run In Standby

The bit controls how the voltage reference behaves during standby sleep mode.

Value	Description
0	The voltage reference is halted during standby sleep mode.
1	The voltage reference is not stopped in standby sleep mode. If VREF.ONDEMAND=1, the voltage reference will be running when a peripheral is requesting it. If VREF.ONDEMAND=0, the voltage reference will always be running in standby sleep mode.

### Bit 3 – TSEL Temperature Sensor Channel Selection

Value	Description
0	The Temperature Sensor PTAT channel is selected.
1	The Temperature Sensor CTAT channel is selected.

### Bit 2 – VREFOE Voltage Reference Output Enable

Value	Description
0	The Voltage Reference output (INTREF) is not available as an ADC input channel.
1	The Voltage Reference output (INTREF) is routed to an ADC input channel.

### Bit 1 – TSEN Temperature Sensor Enable

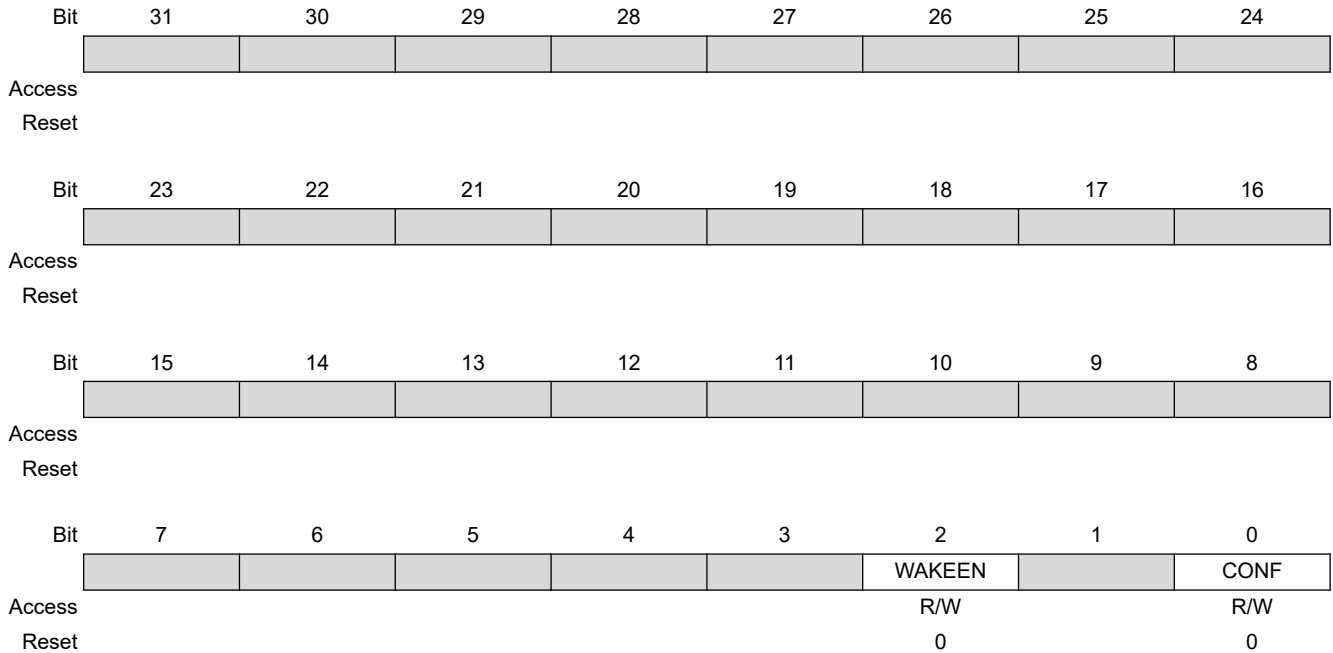
Value	Description
0	Temperature Sensor is disabled.
1	Temperature Sensor is enabled and routed to an ADC input channel.

# SAM D5x/E5x Family Data Sheet

## SUPC – Supply Controller

### 19.8.8 Battery Backup Power Switch (BBPS) Control

**Name:** BBPS  
**Offset:** 0x20  
**Reset:** 0x00000000  
**Property:** PAC Write-Protection



#### Bit 2 – WAKEEN Wake Enable

Value	Description
0	The device is not woken up when switched from battery backup power to Main Power.
1	The device is woken up when switched from battery backup power to Main Power.

#### Bit 0 – CONF Battery Backup Power Switch Configuration

Value	Name	Description
0x0	BOD33	The power switch is handled by the BOD33 according to the BOD33.ACTION bit field.
0x1	FORCED	In backup sleep mode, the backup domain is always supplied by Battery Backup Power.

### 19.8.9 Backup Output (BKOUT) Control

**Name:** BKOUT  
**Offset:** 0x24  
**Reset:** 0x00000000  
**Property:** PAC Write-Protection

	Bit	31	30	29	28	27	26		25	24
									RTCTGL1	RTCTGL0
Access									R/W	R/W
Reset									0	0
	Bit	23	22	21	20	19	18		17	16
									SET1	SET0
Access									W	W
Reset									0	0
	Bit	15	14	13	12	11	10		9	8
									CLR1	CLR0
Access									W	W
Reset									0	0
	Bit	7	6	5	4	3	2		1	0
									EN1	EN0
Access									R/W	R/W
Reset									0	0

#### Bits 24, 25 – RTCTGL RTC Toggle Output

Value	Description
0	The output will not toggle on RTC event.
1	The output will toggle on RTC event.

#### Bits 16, 17 – SET Set Output

Writing a '0' to a bit has no effect.  
 Writing a '1' to a bit will set the corresponding output.  
 Reading this bit returns '0'.

#### Bits 8, 9 – CLR Clear Output

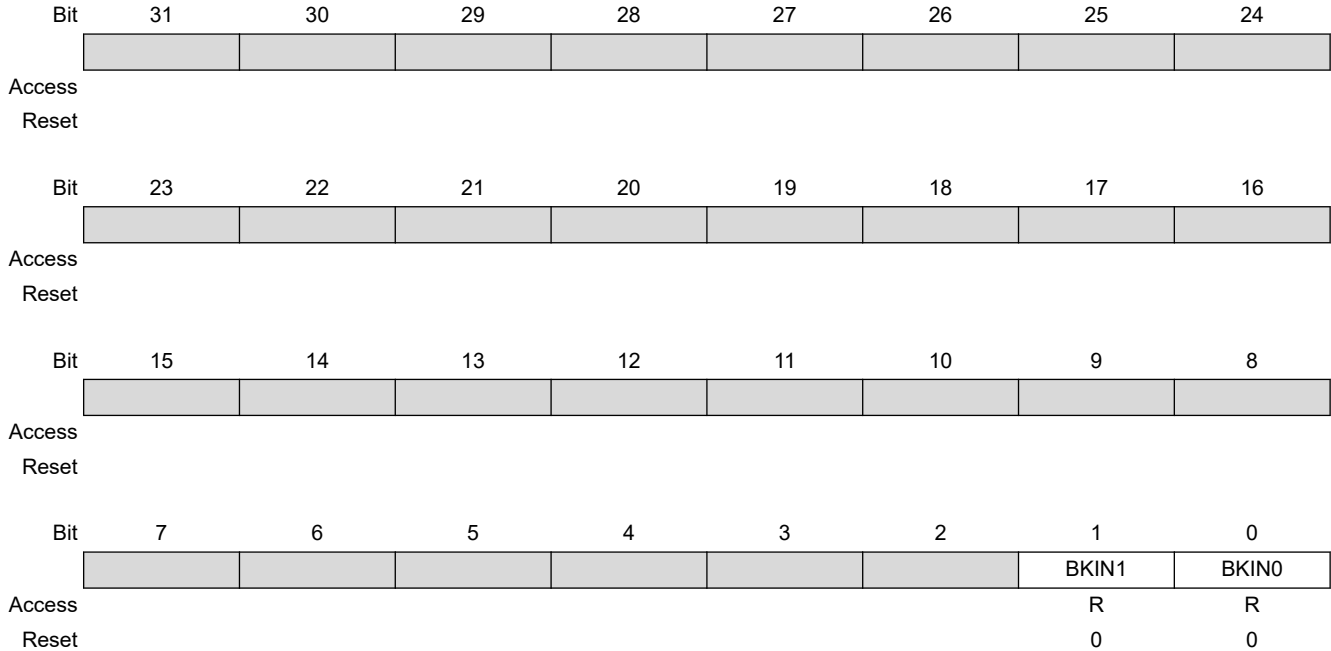
Writing a '0' to a bit has no effect.  
 Writing a '1' to a bit will clear the corresponding output.  
 Reading this bit returns '0'.

#### Bits 0, 1 – EN Enable Output

Value	Description
0	The output is not enabled.
1	The output is enabled and driven by the SUPC.

### 19.8.10 Backup Input (BKIN) Value

**Name:** BKIN  
**Offset:** 0x28  
**Reset:** 0x00000000  
**Property:** -



#### Bits 0, 1 – BKIN Backup Input Value

These bits are cleared when the corresponding backup I/O pin detects a logical low level on the input pin or when the backup I/O is not enabled.

These bits are set when the corresponding backup I/O pin detects a logical high level on the input pin when the backup I/O is enabled.

Value	Name	Description
BKIN[0]	OUT[0]	If BKOUT.EN[0]=1, BKIN[0] will give the input value of the OUT[0] pin
BKIN[1]	OUT[1]	If BKOUT.EN[1]=1, BKIN[1] will give the input value of the OUT[1] pin



## **20. WDT – Watchdog Timer**

### **20.1 Overview**

The Watchdog Timer (WDT) is a system function for monitoring correct program operation. It makes it possible to recover from error situations such as runaway or deadlocked code. The WDT is configured to a predefined time-out period, and is constantly running when enabled. If the WDT is not cleared within the time-out period, it will issue a system reset. An early-warning interrupt is available to indicate an upcoming watchdog time-out condition.

The window mode makes it possible to define a time slot (or window) inside the total time-out period during which the WDT must be cleared. If the WDT is cleared outside this window, either too early or too late, a system reset will be issued. Compared to the normal mode, this can also catch situations where a code error causes the WDT to be cleared frequently.

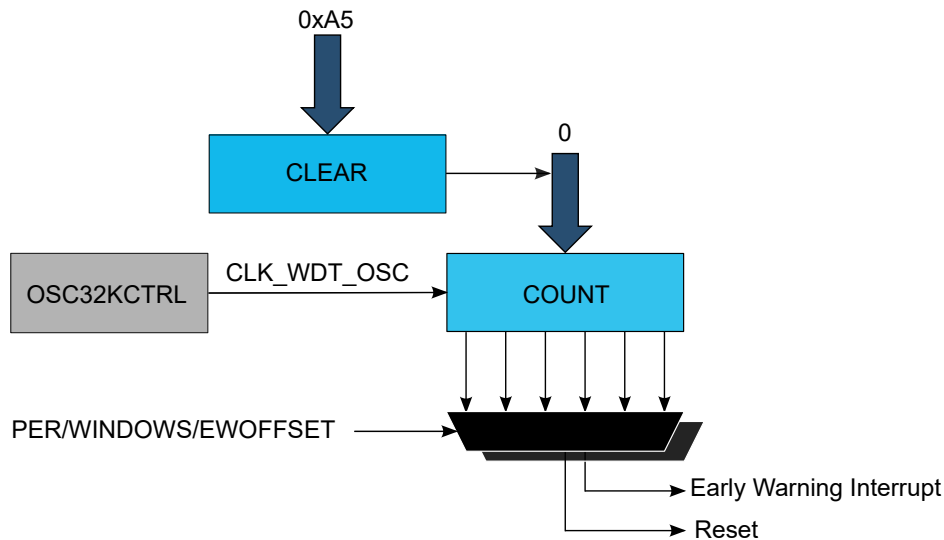
When enabled, the WDT will run in active mode and any sleep modes, except Hibernate, Backup and OFF sleep mode. It is asynchronous and runs from a CPU-independent clock source. The WDT will continue operation and issue a system reset or interrupt even if the main clocks fail.

### **20.2 Features**

- Issues a system reset if the Watchdog Timer is not cleared before its time-out period
- Early Warning interrupt generation
- Asynchronous operation from dedicated oscillator
- Two types of operation
  - Normal
  - Window mode
- Selectable time-out periods
  - From 8 cycles to 16,384 cycles in Normal mode
  - From 16 cycles to 32,768 cycles in Window mode
- Always-On capability

### 20.3 Block Diagram

Figure 20-1. WDT Block Diagram



### 20.4 Signal Description

Not applicable.

### 20.5 Product Dependencies

In order to use this peripheral, other parts of the system must be configured correctly, as described below.

#### 20.5.1 I/O Lines

Not applicable.

#### 20.5.2 Power Management

The WDT can continue to operate in any sleep modes where the selected source clock is running. The WDT interrupts can be used to wake up the device from sleep modes. The events can trigger other operations in the system without exiting sleep modes.

#### Related Links

[18. PM – Power Manager](#)

#### 20.5.3 Clocks

The WDT bus clock (CLK\_WDT\_APB) can be enabled and disabled (masked) in the Main Clock module (MCLK).

A 1.024 kHz oscillator clock (CLK\_WDT\_OSC) is required to clock the WDT internal counter.

The CLK\_WDT\_OSC CLOCK is sourced from the clock of the internal Ultra Low-Power Oscillator (OSCULP32K). Due to ultra low-power design, the oscillator is not accurate, hence the exact time-out period may vary from device-to-device. This variation must be considered when designing software that uses the WDT to ensure that the time-out periods used are valid for all devices.

The counter clock CLK\_WDT\_OSC is asynchronous to the bus clock (CLK\_WDT\_APB). Due to this asynchronicity, writing to certain registers will require synchronization between the clock domains. Refer to [20.6.7 Synchronization](#) for further details.

### Related Links

[15.6.2.6 Peripheral Clock Masking](#)

[29. OSC32KCTRL – 32KHz Oscillators Controller](#)

#### 20.5.4 DMA

Not applicable.

#### 20.5.5 Interrupts

The interrupt request line is connected to the interrupt controller. Using the WDT interrupt(s) requires the interrupt controller to be configured first.

### Related Links

[10.2 Nested Vector Interrupt Controller](#)

#### 20.5.6 Events

Not applicable.

#### 20.5.7 Debug Operation

When the CPU is halted in debug mode the WDT will halt normal operation.

#### 20.5.8 Register Access Protection

All registers with write access can be write-protected optionally by the Peripheral Access Controller (PAC), except for the following registers:

- Interrupt Flag Status and Clear (INTFLAG) register

Optional write protection by the Peripheral Access Controller (PAC) is denoted by the "PAC Write Protection" property in each individual register description.

PAC write protection does not apply to accesses through an external debugger.

#### 20.5.9 Analog Connections

Not applicable.

## 20.6 Functional Description

### 20.6.1 Principle of Operation

The Watchdog Timer (WDT) is a system for monitoring correct program operation, making it possible to recover from error situations such as runaway code, by issuing a Reset. When enabled, the WDT is a constantly running timer that is configured to a predefined time-out period. Before the end of the time-out period, the WDT should be set back, or else, a system Reset is issued.

The WDT has two modes of operation, Normal mode and Window mode. Both modes offer the option of Early Warning interrupt generation. The description for each of the basic modes is given below. The settings in the Control A register (CTRLA) and the Interrupt Enable register (handled by INTENCLR/INTENSET) determine the mode of operation:

**Table 20-1. WDT Operating Modes**

CTRLA.ENABLE	CTRLA.WEN	Interrupt Enable	Mode
0	x	x	Stopped
1	0	0	Normal mode
1	0	1	Normal mode with Early Warning interrupt
1	1	0	Window mode
1	1	1	Window mode with Early Warning interrupt

## 20.6.2 Basic Operation

### 20.6.2.1 Initialization

The following bits are enable-protected, meaning that they can only be written when the WDT is disabled (CTRLA.ENABLE=0):

- Control A register (CTRLA), except the Enable bit (CTRLA.ENABLE)
- Configuration register (CONFIG)
- Early Warning Interrupt Control register (EWCTRL)

Enable-protected bits in the CTRLA register can be written at the same time as CTRLA.ENABLE is written to '1', but not at the same time as CTRLA.ENABLE is written to '0'.

The WDT can be configured only while the WDT is disabled. The WDT is configured by defining the required Time-Out Period bits in the Configuration register (CONFIG.PER). If Window mode operation is desired, the Window Enable bit in the Control A register must be set (CTRLA.WEN=1) and the Window Period bits in the Configuration register (CONFIG.WINDOW) must be defined.

Enable-protection is denoted by the "Enable-Protected" property in the register description.

### 20.6.2.2 Configurable Reset Values

After a Power-on Reset, some registers will be loaded with initial values from the NVM User Row.

This includes the following bits and bit groups:

- Enable bit in the Control A register, CTRLA.ENABLE
- Always-On bit in the Control A register, CTRLA.ALWAYSON
- Watchdog Timer Windows Mode Enable bit in the Control A register, CTRLA.WEN
- Watchdog Timer Windows Mode Time-Out Period bits in the Configuration register, CONFIG.WINDOW
- Time-Out Period bits in the Configuration register, CONFIG.PER
- Early Warning Interrupt Time Offset bits in the Early Warning Interrupt Control register, EWCTRL.EWOFFSET

### 20.6.2.3 Enabling, Disabling, and Resetting

The WDT is enabled by writing a '1' to the Enable bit in the Control A register (CTRLA.ENABLE). The WDT is disabled by writing a '0' to CTRLA.ENABLE.

The WDT can be disabled only if the Always-On bit in the Control A register (CTRLA.ALWAYSON) is '0'.

### 20.6.2.4 Normal Mode

In Normal mode operation, the length of a time-out period is configured in CONFIG.PER. The WDT is enabled by writing a '1' to the Enable bit in the Control A register (CTRLA.ENABLE). Once enabled, the

WDT will issue a system reset if a time-out occurs. This can be prevented by clearing the WDT at any time during the time-out period.

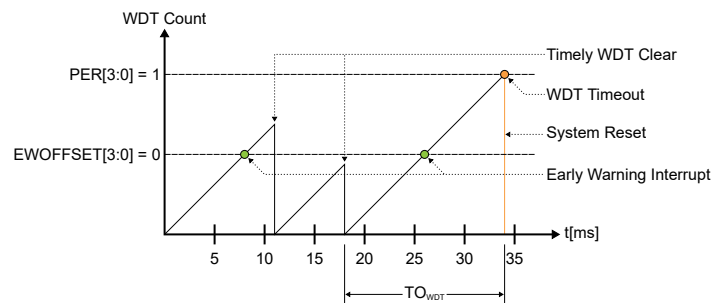
The WDT is cleared and a new WDT time-out period is started by writing 0xA5 to the Clear register (CLEAR). Writing any other value than 0xA5 to CLEAR will issue an immediate system reset.

There are 12 possible WDT time-out ( $TO_{WDT}$ ) periods, selectable from 8ms to 16s.

By default, the early warning interrupt is disabled. If it is desired, the Early Warning Interrupt Enable bit in the Interrupt Enable register (INTENSET.EW) must be written to '1'. The Early Warning Interrupt is disabled again by writing a '1' to the Early Warning Interrupt bit in the Interrupt Enable Clear register (INTENCLR.EW).

If the Early Warning Interrupt is enabled, an interrupt is generated prior to a WDT time-out condition. In Normal mode, the Early Warning Offset bits in the Early Warning Interrupt Control register, EWCTRL.EWOFFSET, define the time when the early warning interrupt occurs. The Normal mode operation is illustrated in the figure Normal-Mode Operation.

**Figure 20-2. Normal-Mode Operation**



### 20.6.2.5 Window Mode

In Window mode operation, the WDT uses two different time specifications: the WDT can only be cleared by writing 0xA5 to the CLEAR register *after* the closed window time-out period ( $TO_{WDTW}$ ), during the subsequent Normal time-out period ( $TO_{WDT}$ ). If the WDT is cleared before the time window opens (before  $TO_{WDTW}$  is over), the WDT will issue a system reset.

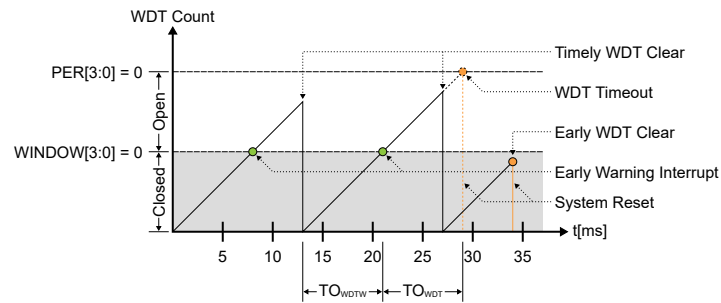
Both parameters  $TO_{WDTW}$  and  $TO_{WDT}$  are periods in a range from 8ms to 16s, so the total duration of the WDT time-out period is the sum of the two parameters.

The closed window period is defined by the Window Period bits in the Configuration register (CONFIG.WINDOW), and the open window period is defined by the Period bits in the Configuration register (CONFIG.PER).

By default, the Early Warning interrupt is disabled. If it is desired, the Early Warning Interrupt Enable bit in the Interrupt Enable register (INTENSET.EW) must be written to '1'. The Early Warning Interrupt is disabled again by writing a '1' to the Early Warning Interrupt bit in the Interrupt Enable Clear (INTENCLR.EW) register.

If the Early Warning interrupt is enabled in Window mode, the interrupt is generated at the start of the open window period, i.e. after  $TO_{WDTW}$ . The Window mode operation is illustrated in figure Window-Mode Operation.

**Figure 20-3. Window-Mode Operation**



### 20.6.3 DMA Operation

Not applicable.

### 20.6.4 Interrupts

The WDT has the following interrupt source:

- Early Warning (EW): Indicates that the counter is approaching the time-out condition.
  - This interrupt is an asynchronous wake-up source.

Each interrupt source has an interrupt flag associated with it. The interrupt flag in the Interrupt Flag Status and Clear (INTFLAG) register is set when the interrupt condition occurs.

Each interrupt can be individually enabled by writing a '1' to the corresponding bit in the Interrupt Enable Set (INTENSET) register, and disabled by writing a '1' to the corresponding bit in the Interrupt Enable Clear (INTENCLR) register.

An interrupt request is generated when the interrupt flag is set and the corresponding interrupt is enabled. The interrupt request remains active until the interrupt flag is cleared, the interrupt is disabled, or the WDT is reset. See the [20.8.6 INTFLAG](#) register description for details on how to clear interrupt flags. All interrupt requests from the peripheral are ORed together on system level to generate one combined interrupt request to the NVIC. The user must read the INTFLAG register to determine which interrupt condition is present.

**Note:** Interrupts must be globally enabled for interrupt requests to be generated.

#### Related Links

[10.2 Nested Vector Interrupt Controller](#)

[18. PM – Power Manager](#)

### 20.6.5 Events

Not applicable.

### 20.6.6 Sleep Mode Operation

The WDT will continue to operate in any sleep mode where the source clock is active except backup mode. The WDT interrupts can be used to wake up the device from a sleep mode. An interrupt request will be generated after the wake-up if the Interrupt Controller is configured accordingly. Otherwise the CPU will wake up directly, without triggering an interrupt. In this case, the CPU will continue executing from the instruction following the entry into sleep.

#### Related Links

[20.8.1 CTRLA](#)

### 20.6.7 Synchronization

Due to asynchronicity between the main clock domain and the peripheral clock domains, some registers need to be synchronized when written or read.

The following registers are synchronized when written:

- Enable bit in Control A register (CTRLA.ENABLE)
- Window Enable bit in Control A register (CTRLA.WEN)
- Always-On bit in control Control A (CTRLA.ALWAYSON)
- Watchdog Clear register (CLEAR)

Required write synchronization is denoted by the "Write-Synchronized" property in the register description.

Required read synchronization is denoted by the "Read-Synchronized" property in the register description.

### 20.6.8 Additional Features

#### 20.6.8.1 Always-On Mode

The Always-On mode is enabled by setting the Always-On bit in the Control A register (CTRLA.ALWAYSON=1). When the Always-On mode is enabled, the WDT runs continuously, regardless of the state of CTRLA.ENABLE. Once written, the Always-On bit can only be cleared by a power-on reset. The Configuration (CONFIG) and Early Warning Control (EWCTRL) registers are read-only registers while the CTRLA.ALWAYSON bit is set. Thus, the time period configuration bits (CONFIG.PER, CONFIG.WINDOW, EWCTRL.EWOFFSET) of the WDT cannot be changed.

Enabling or disabling Window mode operation by writing the Window Enable bit (CTRLA.WEN) is allowed while in Always-On mode, but note that CONFIG.PER cannot be changed.

The Interrupt Clear and Interrupt Set registers are accessible in the Always-On mode. The Early Warning interrupt can still be enabled or disabled while in the Always-On mode, but note that EWCTRL.EWOFFSET cannot be changed.

Table WDT Operating Modes With Always-On shows the operation of the WDT for CTRLA.ALWAYSON=1.

**Table 20-2. WDT Operating Modes With Always-On**

WEN	Interrupt Enable	Mode
0	0	Always-on and normal mode
0	1	Always-on and normal mode with Early Warning interrupt
1	0	Always-on and window mode
1	1	Always-on and window mode with Early Warning interrupt

#### 20.6.8.2 Early Warning

The Early Warning interrupt notifies that the WDT is approaching its time-out condition. The Early Warning interrupt behaves differently in Normal mode and in Window mode.

*In Normal mode*, the Early Warning interrupt generation is defined by the Early Warning Offset in the Early Warning Control register (EWCTRL.EWOFFSET). The Early Warning Offset bits define the number of CLK\_WDT\_OSC clocks before the interrupt is generated, relative to the start of the watchdog time-out period.

# SAM D5x/E5x Family Data Sheet

## WDT – Watchdog Timer

---

The user must take caution when programming the Early Warning Offset bits. If these bits define an Early Warning interrupt generation time greater than the watchdog time-out period, the watchdog time-out system reset is generated prior to the Early Warning interrupt. Consequently, the Early Warning interrupt will never be generated.

*In window mode*, the Early Warning interrupt is generated at the start of the open window period. In a typical application where the system is in sleep mode, the Early Warning interrupt can be used to wake up and clear the Watchdog Timer, after which the system can perform other tasks or return to sleep mode.

If the WDT is operating in Normal mode with CONFIG.PER = 0x2 and EWCTRL.EWOFFSET = 0x1, the Early Warning interrupt is generated 16 CLK\_WDT\_OSC clock cycles after the start of the time-out period. The time-out system reset is generated 32 CLK\_WDT\_OSC clock cycles after the start of the watchdog time-out period.



### 20.7 Register Summary

Offset	Name	Bit Pos.							
0x00	<a href="#">CTRLA</a>	7:0	ALWAYSON					WEN	ENABLE
0x01	<a href="#">CONFIG</a>	7:0	WINDOW[3:0]			PER[3:0]			
0x02	<a href="#">EWCTRL</a>	7:0				EWOFFSET[3:0]			
0x03	Reserved								
0x04	<a href="#">INTENCLR</a>	7:0							EW
0x05	<a href="#">INTENSET</a>	7:0							EW
0x06	<a href="#">INTFLAG</a>	7:0							EW
0x07	Reserved								
0x08	<a href="#">SYNCBUSY</a>	7:0			CLEAR	ALWAYSON	WEN	ENABLE	
		15:8							
		23:16							
		31:24							
0x0C	<a href="#">CLEAR</a>	7:0	CLEAR[7:0]						

### 20.8 Register Description

Registers can be 8, 16, or 32 bits wide. Atomic 8-, 16- and 32-bit accesses are supported. In addition, the 8-bit quarters and 16-bit halves of a 32-bit register, and the 8-bit halves of a 16-bit register can be accessed directly.

Some registers are optionally write-protected by the Peripheral Access Controller (PAC). Optional PAC write protection is denoted by the "PAC Write-Protection" property in each individual register description. For details, refer to [20.5.8 Register Access Protection](#).

Some registers are synchronized when read and/or written. Synchronization is denoted by the "Write-Synchronized" or the "Read-Synchronized" property in each individual register description. For details, refer to [20.6.7 Synchronization](#).

Some registers are enable-protected, meaning they can only be written when the peripheral is disabled. Enable-protection is denoted by the "Enable-Protected" property in each individual register description.

### 20.8.1 Control A

**Name:** CTRLA  
**Offset:** 0x00  
**Reset:** x initially determined from NVM User Row after reset  
**Property:** PAC Write-Protection, Write-Synchronized

	7	6	5	4	3	2	1	0
	ALWAYSON					WEN	ENABLE	
Access	R/W					R/W	R/W	
Reset	x					x	x	

#### Bit 7 – ALWAYSON Always-On

This bit allows the WDT to run continuously. After being set, this bit cannot be written to '0', and the WDT will remain enabled until a power-on Reset is received. When this bit is '1', the Control A register (CTRLA), the Configuration register (CONFIG) and the Early Warning Control register (EWCTRL) will be read-only, and any writes to these registers are not allowed.

Writing a '0' to this bit has no effect.

This bit is not Enable-Protected.

This bit is loaded from NVM User Row at start-up.

Value	Description
0	The WDT is enabled and disabled through the ENABLE bit.
1	The WDT is enabled and can only be disabled by a power-on reset (POR).

#### Bit 2 – WEN Watchdog Timer Window Mode Enable

This bit enables Window mode. It can only be written if the peripheral is disabled unless CTRLA.ALWAYSON=1. The initial value of this bit is loaded from Flash Calibration.

This bit is loaded from NVM User Row at startup.

Value	Description
0	Window mode is disabled (normal operation).
1	Window mode is enabled.

#### Bit 1 – ENABLE Enable

This bit enables or disables the WDT. It can only be written if CTRLA.ALWAYSON=0.

Due to synchronization, there is delay between writing CTRLA.ENABLE until the peripheral is enabled/disabled. The value written to CTRLA.ENABLE will read back immediately, and the Enable bit in the Synchronization Busy register (SYNCBUSY.ENABLE) will be set. SYNCBUSY.ENABLE will be cleared when the operation is complete.

This bit is not Enable-Protected.

This bit is loaded from NVM User Row at startup.

Value	Description
0	The WDT is disabled.
1	The WDT is enabled.

### 20.8.2 Configuration

**Name:** CONFIG  
**Offset:** 0x01  
**Reset:** x initially determined from NVM User Row after reset  
**Property:** PAC Write-Protection

	Bit	7	6	5	4	3	2	1	0
		WINDOW[3:0]				PER[3:0]			
Access		R/W	R/W	R/W	R/W	R/W	R/W	R/W	R/W
Reset		x	x	x	x	x	x	x	x

#### Bits 7:4 – WINDOW[3:0] Window Mode Time-Out Period

In Window mode, these bits determine the watchdog closed window period as a number of cycles of the 1.024kHz CLK\_WDT\_OSC clock.

These bits are loaded from NVM User Row at start-up.

Value	Name	Description
0x0	CYC8	8 clock cycles
0x1	CYC16	16 clock cycles
0x2	CYC32	32 clock cycles
0x3	CYC64	64 clock cycles
0x4	CYC128	128 clock cycles
0x5	CYC256	256 clock cycles
0x6	CYC512	512 clock cycles
0x7	CYC1024	1024 clock cycles
0x8	CYC2048	2048 clock cycles
0x9	CYC4096	4096 clock cycles
0xA	CYC8192	8192 clock cycles
0xB	CYC16384	16384 clock cycles
0xC–0xF	Reserved	Reserved

#### Bits 3:0 – PER[3:0] Time-Out Period

These bits determine the watchdog time-out period as a number of 1.024kHz CLK\_WDTOSC clock cycles. In Window mode operation, these bits define the open window period.

These bits are loaded from NVM User Row at startup.

Value	Name	Description
0x0	CYC8	8 clock cycles
0x1	CYC16	16 clock cycles
0x2	CYC32	32 clock cycles
0x3	CYC64	64 clock cycles
0x4	CYC128	128 clock cycles
0x5	CYC256	256 clock cycles
0x6	CYC512	512 clock cycles
0x7	CYC1024	1024 clock cycles
0x8	CYC2048	2048 clock cycles
0x9	CYC4096	4096 clock cycles
0xA	CYC8192	8192 clock cycles
0xB	CYC16384	16384 clock cycles

# SAM D5x/E5x Family Data Sheet

## WDT – Watchdog Timer

---

---

Value	Name	Description
0xC - 0xF	-	Reserved

# SAM D5x/E5x Family Data Sheet

## WDT – Watchdog Timer

### 20.8.3 Early Warning Control

**Name:** EWCTRL  
**Offset:** 0x02  
**Reset:** x initially determined from NVM User Row after reset  
**Property:** PAC Write-Protection

	7	6	5	4	3	2	1	0
					EWOFFSET[3:0]			
Access					R/W	R/W	R/W	R/W
Reset					x	x	x	x

**Bits 3:0 – EWOFFSET[3:0]** Early Warning Interrupt Time Offset

These bits determine the number of GCLK\_WDT clock cycles between the start of the watchdog time-out period and the generation of the Early Warning interrupt. These bits are loaded from NVM User Row at start-up.

Value	Name	Description
0x0	CYC8	8 clock cycles
0x1	CYC16	16 clock cycles
0x2	CYC32	32 clock cycles
0x3	CYC64	64 clock cycles
0x4	CYC128	128 clock cycles
0x5	CYC256	256 clock cycles
0x6	CYC512	512 clock cycles
0x7	CYC1024	1024 clock cycles
0x8	CYC2048	2048 clock cycles
0x9	CYC4096	4096 clock cycles
0xA	CYC8192	8192 clock cycles
0xB – 0xF	Reserved	Reserved

### 20.8.4 Interrupt Enable Clear

**Name:** INTENCLR  
**Offset:** 0x04  
**Reset:** 0x00  
**Property:** PAC Write-Protection

This register allows the user to disable an interrupt without doing a read-modify-write operation. Changes in this register will also be reflected in the Interrupt Enable Set (INTENSET) register.

	7	6	5	4	3	2	1	0
								EW
Access								R/W
Reset								0

**Bit 0 – EW** Early Warning Interrupt Enable

Writing a '0' to this bit has no effect.

Writing a '1' to this bit clears the Early Warning Interrupt Enable bit, which disables the Early Warning interrupt.

Value	Description
0	The Early Warning interrupt is disabled.
1	The Early Warning interrupt is enabled.

### 20.8.5 Interrupt Enable Set

**Name:** INTENSET  
**Offset:** 0x05  
**Reset:** 0x00  
**Property:** PAC Write-Protection

This register allows the user to enable an interrupt without doing a read-modify-write operation. Changes in this register will also be reflected in the Interrupt Enable Clear (INTENCLR) register.

	7	6	5	4	3	2	1	0
								EW
Access								R/W
Reset								0

**Bit 0 – EW** Early Warning Interrupt Enable

Writing a '0' to this bit has no effect.

Writing a '1' to this bit sets the Early Warning Interrupt Enable bit, which enables the Early Warning interrupt.

Value	Description
0	The Early Warning interrupt is disabled.
1	The Early Warning interrupt is enabled.

### 20.8.6 Interrupt Flag Status and Clear

**Name:** INTFLAG  
**Offset:** 0x06  
**Reset:** 0x00  
**Property:** N/A

Bit	7	6	5	4	3	2	1	0
								EW
Access								R/W
Reset								0

#### **Bit 0 – EW** Early Warning

This flag is cleared by writing a '1' to it.

This flag is set when an Early Warning interrupt occurs, as defined by the EWOFFSET bit group in EWCTRL.

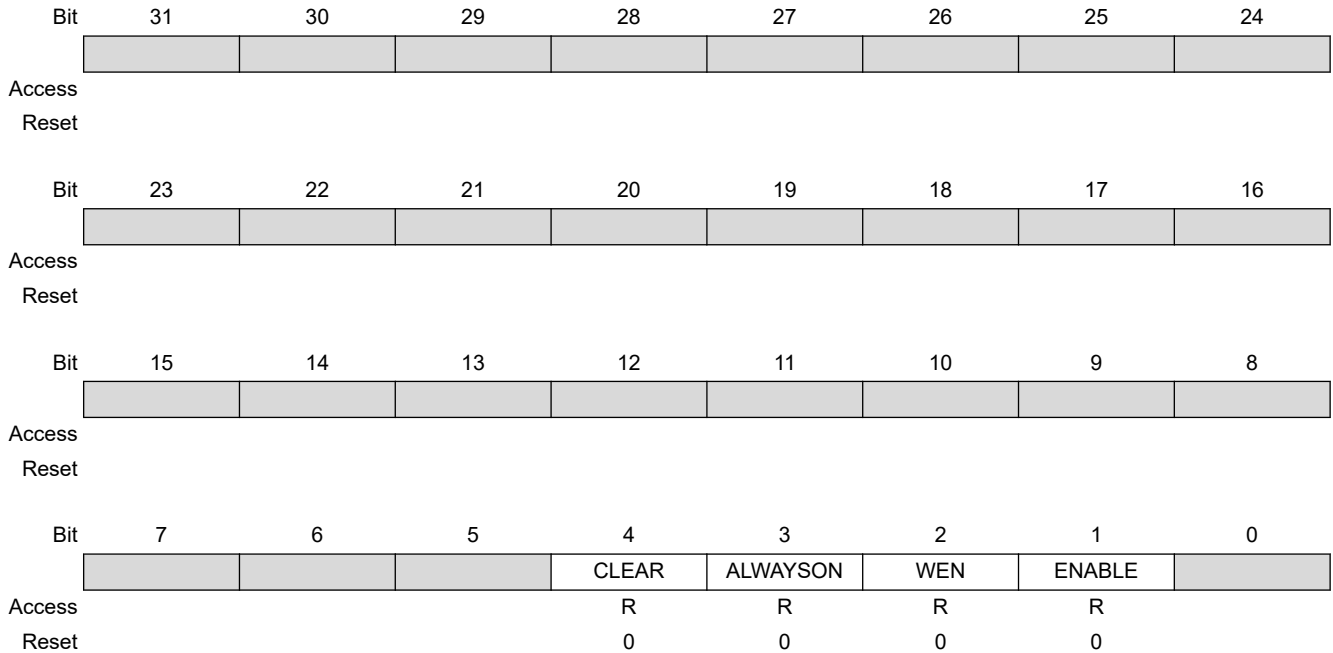
Writing a '0' to this bit has no effect.

Writing a '1' to this bit clears the Early Warning interrupt flag.



### 20.8.7 Synchronization Busy

**Name:** SYNCBUSY  
**Offset:** 0x08  
**Reset:** 0x00000000  
**Property:** -



#### Bit 4 – CLEAR Clear Synchronization Busy

Value	Description
0	Write synchronization of the CLEAR register is complete.
1	Write synchronization of the CLEAR register is ongoing.

#### Bit 3 – ALWAYSON Always-On Synchronization Busy

Value	Description
0	Write synchronization of the CTRLA.ALWAYSON bit is complete.
1	Write synchronization of the CTRLA.ALWAYSON bit is ongoing.

#### Bit 2 – WEN Window Enable Synchronization Busy

Value	Description
0	Write synchronization of the CTRLA.WEN bit is complete.
1	Write synchronization of the CTRLA.WEN bit is ongoing.

#### Bit 1 – ENABLE Enable Synchronization Busy

Value	Description
0	Write synchronization of the CTRLA.ENABLE bit is complete.
1	Write synchronization of the CTRLA.ENABLE bit is ongoing.

### 20.8.8 Clear

**Name:** CLEAR  
**Offset:** 0x0C  
**Reset:** 0x00  
**Property:** Write-Synchronized

Bit	7	6	5	4	3	2	1	0
	CLEAR[7:0]							
Access	W	W	W	W	W	W	W	W
Reset	0	0	0	0	0	0	0	0

#### Bits 7:0 – CLEAR[7:0] Watchdog Clear

In Normal mode, writing 0xA5 to this register during the watchdog time-out period will clear the Watchdog Timer and the watchdog time-out period is restarted.

In Window mode, any writing attempt to this register before the time-out period started (i.e., during  $TO_{WDTW}$ ) will issue an immediate system Reset. Writing 0xA5 during the time-out period  $TO_{WDT}$  will clear the Watchdog Timer and the complete time-out sequence (first  $TO_{WDTW}$  then  $TO_{WDT}$ ) is restarted.

In both modes, writing any other value than 0xA5 will issue an immediate system Reset.

## 21. RTC – Real-Time Counter

### 21.1 Overview

The Real-Time Counter (RTC) is a 32-bit counter with a 10-bit programmable prescaler that typically runs continuously to keep track of time. The RTC can wake up the device from sleep modes using the alarm/compare wake up, periodic wake up, or overflow wake up mechanisms, or from the wake inputs.

The RTC can generate periodic peripheral events from outputs of the prescaler, as well as alarm/compare interrupts and peripheral events, which can trigger at any counter value. Additionally, the timer can trigger an overflow interrupt and peripheral event, and can be reset on the occurrence of an alarm/compare match. This allows periodic interrupts and peripheral events at very long and accurate intervals.

The 10-bit programmable prescaler can scale down the clock source. By this, a wide range of resolutions and time-out periods can be configured. With a 32.768kHz clock source, the minimum counter tick interval is 30.5 $\mu$ s, and time-out periods can range up to 36 hours. For a counter tick interval of 1s, the maximum time-out period is more than 136 years.

### 21.2 Features

- 32-bit counter with 10-bit prescaler
- Multiple clock sources
- 32-bit or 16-bit counter mode
- Two 32-bit or four 16-bit compare values
- Clock/Calendar mode
  - Time in seconds, minutes, and hours (12/24)
  - Date in day of month, month, and year
  - Leap year correction
- Digital prescaler correction/tuning for increased accuracy
- Overflow, alarm/compare match and prescaler interrupts and events
  - Optional clear on alarm/compare match
- 8 backup registers with retention capability
- Tamper Detection
  - Timestamp on event or up to 5 inputs with debouncing
  - Active layer protection

### 21.3 Block Diagram

Figure 21-1. RTC Block Diagram (Mode 0 — 32-Bit Counter)

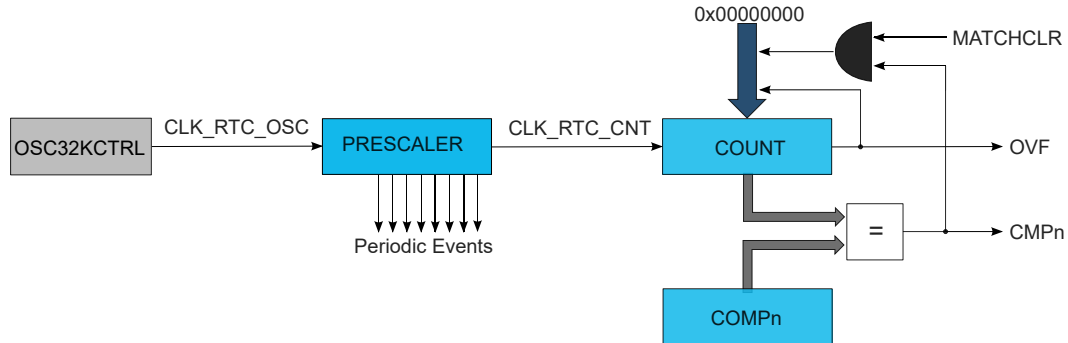


Figure 21-2. RTC Block Diagram (Mode 1 — 16-Bit Counter)

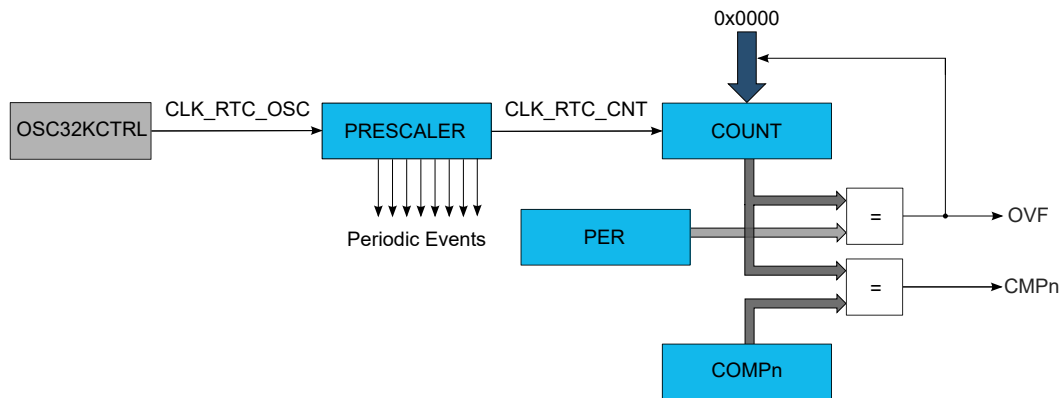
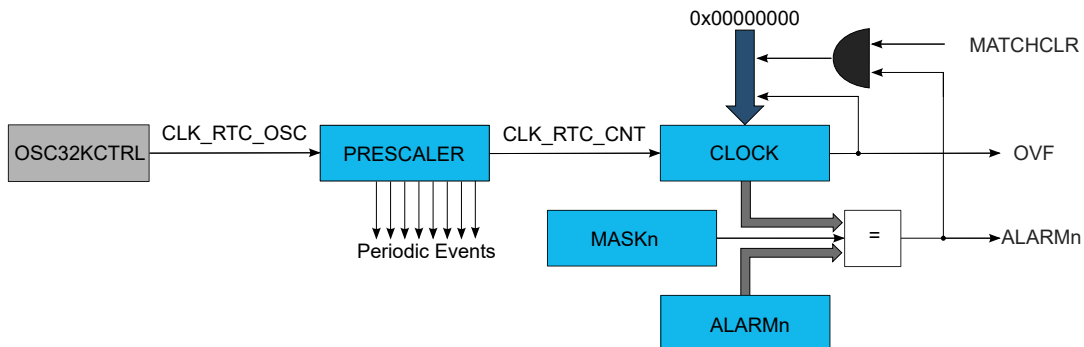


Figure 21-3. RTC Block Diagram (Mode 2 — Clock/Calendar)



#### Related Links

- [21.6.2.3 32-Bit Counter \(Mode 0\)](#)
- [21.6.2.4 16-Bit Counter \(Mode 1\)](#)
- [21.6.2.5 Clock/Calendar \(Mode 2\)](#)
- [21.6.8.5 Tamper Detection](#)

### 21.4 Signal Description

**Table 21-1. Signal Description**

Signal	Description	Type
INn [n=0..4]	Tamper Detection Input	Digital input
OUT	Tamper Detection Output	Digital output

One signal can be mapped to one of several pins.

**Related Links**

[6. I/O Multiplexing and Considerations](#)

### 21.5 Product Dependencies

In order to use this peripheral, other parts of the system must be configured correctly, as described below.

#### 21.5.1 I/O Lines

For more information on I/O configurations, refer to the "RTC Pinout" section.

**Related Links:** [I/O Multiplexing and Considerations](#)

#### 21.5.2 Power Management

The RTC will continue to operate in any sleep mode where the selected source clock is running. The RTC interrupts can be used to wake up the device from sleep modes. Events connected to the event system can trigger other operations in the system without exiting sleep modes. Refer to the *Power Manager* for details on the different sleep modes.

The RTC will be reset only at power-on (POR) or by setting the Software Reset bit in the Control A register (CTRLA.SWRST=1).

**Related Links**

[18. PM – Power Manager](#)

#### 21.5.3 Clocks

The RTC bus clock (CLK\_RTC\_APB) can be enabled and disabled in the Main Clock module MCLK, and the default state of CLK\_RTC\_APB can be found in Peripheral Clock Masking section.

A 32KHz or 1KHz oscillator clock (CLK\_RTC\_OSC) is required to clock the RTC. This clock must be configured and enabled in the 32KHz oscillator controller (OSC32CTRL) before using the RTC.

This oscillator clock is asynchronous to the bus clock (CLK\_RTC\_APB). Due to this asynchronicity, writing to certain registers will require synchronization between the clock domains. Refer to [21.6.7 Synchronization](#) for further details.

**Related Links**

[29. OSC32CTRL – 32KHz Oscillators Controller](#)

[15.6.2.6 Peripheral Clock Masking](#)

#### 21.5.4 DMA

The DMA request lines (or line if only one request) are connected to the DMA Controller (DMAC). Using the RTC DMA requests requires the DMA Controller to be configured first.

### Related Links

[22. DMAC – Direct Memory Access Controller](#)

### 21.5.5 Interrupts

The interrupt request line is connected to the Interrupt Controller. Using the RTC interrupt requires the Interrupt Controller to be configured first.

### Related Links

[10.2 Nested Vector Interrupt Controller](#)

### 21.5.6 Events

The events are connected to the *Event System*.

### Related Links

[31. EVSYS – Event System](#)

### 21.5.7 Debug Operation

When the CPU is halted in debug mode the RTC will halt normal operation. The RTC can be forced to continue operation during debugging. Refer to [21.8.7 DBGCTRL](#) for details.

### 21.5.8 Register Access Protection

All registers with write-access are optionally write-protected by the peripheral access controller (PAC), except the following registers:

- Interrupt Flag Status and Clear (INTFLAG) register

Write-protection is denoted by the "PAC Write-Protection" property in the register description.

Write-protection does not apply to accesses through an external debugger. Refer to the PAC - Peripheral Access Controller for details.

### Related Links

[27. PAC - Peripheral Access Controller](#)

### 21.5.9 Analog Connections

A 32.768kHz crystal can be connected to the XIN32 and XOUT32 pins, along with any required load capacitors. See the Electrical Characteristics Chapters for details on recommended crystal characteristics and load capacitors.

## 21.6 Functional Description

### 21.6.1 Principle of Operation

The RTC keeps track of time in the system and enables periodic events, as well as interrupts and events at a specified time. The RTC consists of a 10-bit prescaler that feeds a 32-bit counter. The actual format of the 32-bit counter depends on the RTC operating mode.

The RTC can function in one of these modes:

- Mode 0 - COUNT32: RTC serves as 32-bit counter
- Mode 1 - COUNT16: RTC serves as 16-bit counter
- Mode 2 - CLOCK: RTC serves as clock/calendar with alarm functionality

## 21.6.2 Basic Operation

### 21.6.2.1 Initialization

The following bits are enable-protected, meaning that they can only be written when the RTC is disabled (CTRLA.ENABLE=0):

- Operating Mode bits in the Control A register (CTRLA.MODE)
- Prescaler bits in the Control A register (CTRLA.PRESCALER)
- Clear on Match bit in the Control A register (CTRLA.MATCHCLR)
- Clock Representation bit in the Control A register (CTRLA.CLKREP)

The following registers are enable-protected:

- Control B register (CTRLB)
- Event Control register (EVCTRL)
- Tamper Control register (TAMPCTRL)

Enable-protected bits and registers can be changed only when the RTC is disabled (CTRLA.ENABLE=0). If the RTC is enabled (CTRLA.ENABLE=1), these operations are necessary: first write CTRLA.ENABLE=0 and check whether the write synchronization has finished, then change the desired bit field value. Enable-protected bits in CTRLA register can be written at the same time as CTRLA.ENABLE is written to '1', but not at the same time as CTRLA.ENABLE is written to '0'.

Enable-protection is denoted by the "Enable-Protected" property in the register description.

The RTC prescaler divides the source clock for the RTC counter.

**Note:** In Clock/Calendar mode, the prescaler must be configured to provide a 1Hz clock to the counter for correct operation.

The frequency of the RTC clock (CLK\_RTC\_CNT) is given by the following formula:

$$f_{\text{CLK\_RTC\_CNT}} = \frac{f_{\text{CLK\_RTC\_OSC}}}{2^{\text{PRESCALER}}}$$

The frequency of the oscillator clock, CLK\_RTC\_OSC, is given by  $f_{\text{CLK\_RTC\_OSC}}$ , and  $f_{\text{CLK\_RTC\_CNT}}$  is the frequency of the internal prescaled RTC clock, CLK\_RTC\_CNT.

### 21.6.2.2 Enabling, Disabling, and Resetting

The RTC is enabled by setting the Enable bit in the Control A register (CTRLA.ENABLE=1). The RTC is disabled by writing CTRLA.ENABLE=0.

The RTC is reset by setting the Software Reset bit in the Control A register (CTRLA.SWRST=1). All registers in the RTC, except DEBUG, will be reset to their initial state, and the RTC will be disabled. The RTC must be disabled before resetting it.

### 21.6.2.3 32-Bit Counter (Mode 0)

When the RTC Operating Mode bits in the Control A register (CTRLA.MODE) are written to 0x0, the counter operates in 32-bit Counter mode. The block diagram of this mode is shown in [Figure 21-1](#). When the RTC is enabled, the counter will increment on every 0-to-1 transition of CLK\_RTC\_CNT. The counter will increment until it reaches the top value of 0xFFFFFFFF, and then wrap to 0x00000000. This sets the Overflow Interrupt flag in the Interrupt Flag Status and Clear register (INTFLAG.OVF).

The RTC counter value can be read from or written to the Counter Value register (COUNT) in 32-bit format.

The counter value is continuously compared with the 32-bit Compare registers (COMPn, n=0–1). When a compare match occurs, the Compare n Interrupt flag in the Interrupt Flag Status and Clear register (INTFLAG.CMPn) is set on the next 0-to-1 transition of CLK\_RTC\_CNT.

If the Clear on Match bit in the Control A register (CTRLA.MATCHCLR) is '1', the counter is cleared on the next counter cycle when a compare match with COMPn occurs. This allows the RTC to generate periodic interrupts or events with longer periods than the prescaler events. Note that when CTRLA.MATCHCLR is '1', INTFLAG.CMPn and INTFLAG.OVF will both be set simultaneously on a compare match with COMPn.

### 21.6.2.4 16-Bit Counter (Mode 1)

When the RTC Operating Mode bits in the Control A register (CTRLA.MODE) are written to 0x1, the counter operates in 16-bit Counter mode as shown in [Figure 21-2](#). When the RTC is enabled, the counter will increment on every 0-to-1 transition of CLK\_RTC\_CNT. In 16-bit Counter mode, the 16-bit Period register (PER) holds the maximum value of the counter. The counter will increment until it reaches the PER value, and then wrap to 0x0000. This sets the Overflow Interrupt flag in the Interrupt Flag Status and Clear register (INTFLAG.OVF).

The RTC counter value can be read from or written to the Counter Value register (COUNT) in 16-bit format.

The counter value is continuously compared with the 16-bit Compare registers (COMPn, n=0..). When a compare match occurs, the Compare n Interrupt flag in the Interrupt Flag Status and Clear register (INTFLAG.CMPn, n=0..) is set on the next 0-to-1 transition of CLK\_RTC\_CNT.

### 21.6.2.5 Clock/Calendar (Mode 2)

When the RTC Operating Mode bits in the Control A register (CTRLA.MODE) are written to 0x2, the counter operates in Clock/Calendar mode, as shown in [Figure 21-3](#). When the RTC is enabled, the counter will increment on every 0-to-1 transition of CLK\_RTC\_CNT. The selected clock source and RTC prescaler must be configured to provide a 1Hz clock to the counter for correct operation in this mode.

The time and date can be read from or written to the Clock Value register (CLOCK) in a 32-bit time/date format. Time is represented as:

- Seconds
- Minutes
- Hours

Hours can be represented in either 12- or 24-hour format, selected by the Clock Representation bit in the Control A register (CTRLA.CLKREP). This bit can be changed only while the RTC is disabled.

The date is represented in this form:

- Day as the numeric day of the month (starting at 1)
- Month as the numeric month of the year (1 = January, 2 = February, etc.)
- Year as a value from 0x00 to 0x3F. This value must be added to a user-defined reference year. The reference year must be a leap year (2016, 2020 etc). Example: the year value 0x2D, added to a reference year 2016, represents the year 2061.

The RTC will increment until it reaches the top value of 23:59:59 December 31 of year value 0x3F, and then wrap to 00:00:00 January 1 of year value 0x00. This will set the Overflow Interrupt flag in the Interrupt Flag Status and Clear registers (INTFLAG.OVF).

The clock value is continuously compared with the 32-bit Alarm registers (ALARMn, n=0–1). When an alarm match occurs, the Alarm n Interrupt flag in the Interrupt Flag Status and Clear registers



---

(INTFLAG.ALARMn, n=0..1) is set on the next 0-to-1 transition of CLK\_RTC\_CNT. E.g. For a 1Hz clock counter, it means the Alarm 0 Interrupt flag is set with a delay of 1s after the occurrence of alarm match.

A valid alarm match depends on the setting of the Alarm Mask Selection bits in the Alarm n Mask register (MASKn.SEL). These bits determine which time/date fields of the clock and alarm values are valid for comparison and which are ignored.

If the Clear on Match bit in the Control A register (CTRLA.MATCHCLR) is set, the counter is cleared on the next counter cycle when an alarm match with ALARMn occurs. This allows the RTC to generate periodic interrupts or events with longer periods than it would be possible with the prescaler events only (see [21.6.8.1 Periodic Intervals](#)).

**Note:** When CTRLA.MATCHCLR is 1, INTFLAG.ALARM0 and INTFLAG.OVF will both be set simultaneously on an alarm match with ALARMn.

### 21.6.3 DMA Operation

The RTC generates the following DMA request:

- Tamper (TAMPER): The request is set on capture of the timestamp. The request is cleared when the Timestamp register is read.

If the CPU accesses the registers which are source for DMA request set/clear condition, the DMA request can be lost or the DMA transfer can be corrupted, if enabled.

### 21.6.4 Interrupts

The RTC has the following interrupt sources:

- Overflow (OVF): Indicates that the counter has reached its top value and wrapped to zero.
- Tamper (TAMPER): Indicates detection of valid signal on a tamper input pin or tamper event input.
- Compare (CMPn): Indicates a match between the counter value and the compare register.
- Alarm (ALARMn): Indicates a match between the clock value and the alarm register.
- Period n (PERn): The corresponding bit in the prescaler has toggled. Refer to [21.6.8.1 Periodic Intervals](#) for details.

Each interrupt source has an interrupt flag associated with it. The interrupt flag in the Interrupt Flag Status and Clear (INTFLAG) register is set when the interrupt condition occurs. Each interrupt can be individually enabled by setting the corresponding bit in the Interrupt Enable Set register (INTENSET=1), and disabled by setting the corresponding bit in the Interrupt Enable Clear register (INTENCLR=1).

An interrupt request is generated when the interrupt flag is raised and the corresponding interrupt is enabled. The interrupt request remains active until either the interrupt flag is cleared, the interrupt is disabled or the RTC is reset. See the description of the INTFLAG registers for details on how to clear interrupt flags.

All interrupt requests from the peripheral are ORed together on system level to generate one combined interrupt request to the NVIC. Refer to the Nested Vector Interrupt Controller for details. The user must read the INTFLAG register to determine which interrupt condition is present.

**Note:** Interrupts must be globally enabled for interrupt requests to be generated. Refer to the Nested Vector Interrupt Controller for details.

#### Related Links

[10.2 Nested Vector Interrupt Controller](#)

### 21.6.5 Events

The RTC can generate the following output events:

- Overflow (OVF): Generated when the counter has reached its top value and wrapped to zero.
- Tamper (TAMPER): Generated on detection of valid signal on a tamper input pin or tamper event input.
- Compare (CMPn): Indicates a match between the counter value and the compare register.
- Alarm (ALARM): Indicates a match between the clock value and the alarm register.
- Period n (PERn): The corresponding bit in the prescaler has toggled. Refer to [21.6.8.1 Periodic Intervals](#) for details.
- Periodic Daily (PERD): Generated when the COUNT/CLOCK has incremented at a fixed period of time.

Setting the Event Output bit in the Event Control Register (EVCTRL.xxxEO=1) enables the corresponding output event. Writing a zero to this bit disables the corresponding output event. Refer to the EVSYS - Event System for details on configuring the event system.

The RTC can take the following actions on an input event:

- Tamper (TAMPEVT): Capture the RTC counter to the timestamp register. See *Tamper Detection*.

Writing a one to an Event Input bit into the Event Control register (EVCTRL.xxxEI) enables the corresponding action on input event. Writing a zero to this bit disables the corresponding action on input event.

#### Related Links

[31. EVSYS – Event System](#)

### 21.6.6 Sleep Mode Operation

The RTC will continue to operate in any sleep mode where the source clock is active. The RTC *interrupts* can be used to wake up the device from a sleep mode. RTC *events* can trigger other operations in the system without exiting the sleep mode.

An interrupt request will be generated after the wake-up if the Interrupt Controller is configured accordingly. Otherwise the CPU will wake up directly, without triggering any interrupt. In this case, the CPU will continue executing right from the first instruction that followed the entry into sleep.

The periodic events can also wake up the CPU through the interrupt function of the Event System. In this case, the event must be enabled and connected to an event channel with its interrupt enabled. See *Event System* for more information.

### 21.6.7 Synchronization

Due to asynchronicity between the main clock domain and the peripheral clock domains, some registers need to be synchronized when written or read.

The following bits are synchronized when written:

- Software Reset bit in Control A register, CTRLA.SWRST
- Enable bit in Control A register, CTRLA.ENABLE
- Count Read Synchronization bit in Control A register (CTRLA.COUNTSYNC)
- Clock Read Synchronization bit in Control A register (CTRLA.COUNTSYNC)

The following registers are synchronized when written:

- Counter Value register, COUNT
- Clock Value register, CLOCK
- Counter Period register, PER
- Compare n Value registers, COMPn
- Alarm n Value registers, ALARMn
- Frequency Correction register, FREQCORR
- Alarm n Mask register, MASKn
- The General Purpose n registers (GPn)

The following registers are synchronized when read:

- The Counter Value register, COUNT, if the Counter Read Sync Enable bit in CTRLA (CTRLA.COUNTSYNC) is '1'
- The Clock Value register, CLOCK, if the Clock Read Sync Enable bit in CTRLA (CTRLA.CLOCKSYNC) is '1'
- The Timestamp Value register (TIMESTAMP)

Required write synchronization is denoted by the "Write-Synchronized" property in the register description.

Required read synchronization is denoted by the "Read-Synchronized" property in the register description.

### Related Links

[13.3 Register Synchronization](#)

## 21.6.8 Additional Features

### 21.6.8.1 Periodic Intervals

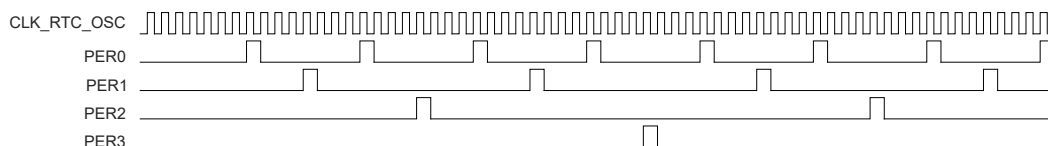
The RTC prescaler can generate interrupts and events at periodic intervals, allowing flexible system tick creation. Any of the upper eight bits of the prescaler (bits 2 to 9) can be the source of an interrupt/event. When one of the eight Periodic Event Output bits in the Event Control register (EVCTRL.PEEO[n=0..7]) is '1', an event is generated on the 0-to-1 transition of the related bit in the prescaler, resulting in a periodic event frequency of:

$$f_{\text{PERIODIC}(n)} = \frac{f_{\text{CLK\_RTC\_OSC}}}{2^{n+3}}$$

$f_{\text{CLK\_RTC\_OSC}}$  is the frequency of the internal prescaler clock CLK\_RTC\_OSC, and n is the position of the EVCTRL.PEEO[n] bit. For example, PER0 will generate an event every eight CLK\_RTC\_OSC cycles, PER1 every 16 cycles, etc. This is shown in the figure below.

Periodic events are independent of the prescaler setting used by the RTC counter, except if CTRLA.PRESCALER is zero. Then, no periodic events will be generated.

**Figure 21-4. Example Periodic Events**



### 21.6.8.2 Frequency Correction

The RTC Frequency Correction module employs periodic counter corrections to compensate for a too-slow or too-fast oscillator. Frequency correction requires that CTRLA.PRESCALER is greater than 1.

The digital correction circuit adds or subtracts cycles from the RTC prescaler to adjust the frequency in approximately 1ppm steps. Digital correction is achieved by adding or skipping a single count in the prescaler once every 8192 CLK\_RTC\_OSC cycles. The Value bit group in the Frequency Correction register (FREQCORR.VALUE) determines the number of times the adjustment is applied over 128 of these periods. The resulting correction is as follows:

$$\text{Correction in ppm} = \frac{\text{FREQCORR.VALUE}}{8192 \cdot 128} \cdot 10^6 \text{ ppm}$$

This results in a resolution of 0.95367ppm.

The Sign bit in the Frequency Correction register (FREQCORR.SIGN) determines the direction of the correction. A positive value will add counts and increase the period (reducing the frequency), and a negative value will reduce counts per period (speeding up the frequency).

Digital correction also affects the generation of the periodic events from the prescaler. When the correction is applied at the end of the correction cycle period, the interval between the previous periodic event and the next occurrence may also be shortened or lengthened depending on the correction value.

### 21.6.8.3 Backup Registers

The RTC includes eight Backup registers (BKUPn). These registers maintain their content in Backup sleep mode. They can be used to store user-defined values.

If more user-defined data must be stored than the eight Backup registers can hold, the General Purpose registers (GPn) can be used.

#### Related Links

[18. PM – Power Manager](#)

### 21.6.8.4 General Purpose Registers

The RTC includes four General Purpose registers (GPn). These registers are reset only when the RTC is reset or when tamper detection occurs while CTRLA.GPTRST=1, and remain powered while the RTC is powered. They can be used to store user-defined values while other parts of the system are powered off.

The general purpose registers 2\*n and 2\*n+1 are enabled by writing a '1' to the General Purpose Enable bit n in the Control B register (CTRLB.GPnEN).

The GP registers share internal resources with the COMPARE/ALARM features. Each COMPARE/ALARM register have a separate read buffer and write buffer. When the general purpose feature is enabled the even GP uses the read buffer while the odd GP uses the write buffer.

When the COMPARE/ALARM register is written, the write buffer hold temporarily the COMPARE/ALARM value until the synchronisation is complete (bit SYNCBUSY.COMPn going to 0). After the write is completed the write buffer can be used as a odd general purpose register without affecting the COMPARE/ALARM function.

If the COMPARE/ALARM function is not used, the read buffer can be used as an even general purpose register. In this case writing the even GP will temporarily use the write buffer until the synchronisation is complete (bit SYNCBUSY.GPn going to 0). Thus an even GP must be written before writing the odd GP. Changing or writing an even GP needs to temporarily save the value of the odd GP.

Before using an even GP, the associated COMPARE/ALARM feature must be disabled by writing a '1' to the General Purpose Enable bit in the Control B register (CTRLB.GPnEN). To re-enable the compare/

alarm, CTRLB.GPnEN must be written to zero and the associated COMPn/ALARMn must be written with the correct value.

An example procedure to write the general purpose registers GP0 and GP1 is:

1. Wait for any ongoing write to COMP0 to complete (SYNCBUSY.COMP0 = 0). If the RTC is operating in Mode 1, wait for any ongoing write to COMP1 to complete as well (SYNCBUSY.COMP1 = 0).
2. Write CTRLB.GP0EN = 1 if GP0 is needed.
3. Write GP0 if needed.
4. Wait for any ongoing write to GP0 to complete (SYNCBUSY.GP0 = 0). Note that GP1 will also show as busy when GP0 is busy.
5. Write GP1 if needed.

The following table provides the correspondence of General Purpose Registers and the COMPARE/ALARM read or write buffer in all RTC modes.

**Table 21-2. General Purpose Registers Versus Compare/Alarm Registers: n in 0, 2, 4, 6...**

Register	Mode 0	Mode 1	Mode 2	Write Before
GPn	COMPn/2 write buffer	(COMPn , COMPn +1) write buffer	ALARMn/2 write buffer	GPn+1
GPn+1	COMPn/2 read buffer	(COMPn , COMPn +1) read buffer	ALARMn/2 read buffer	-

### 21.6.8.5 Tamper Detection

The RTC provides four tamper channels that can be used for tamper detection.

The action of each tamper channel is configured using the Input n Action bits in the Tamper Control register (TAMPCTRL.INnACT):

- Off: Detection for tamper channel n is disabled.
- Wake: A transition on INn input (tamper channel n) matching TAMPCTRL.TAMPLVLn will be detected and the tamper interrupt flag (INTFLAG.TAMPER) will be set. The RTC value will not be captured in the TIMESTAMP register.
- Capture: A transition on INn input (tamper channel n) matching TAMPCTRL.TAMPLVLn will be detected and the tamper interrupt flag (INTFLAG.TAMPER) will be set. The RTC value will be captured in the TIMESTAMP register.
- Active Layer Protection: A mismatch of an internal RTC signal routed between INn and OUTn pins will be detected and the tamper interrupt flag (INTFLAG.TAMPER) will be set. The RTC value will be captured in the TIMESTAMP register.

In order to determine which tamper source caused a tamper event, the Tamper ID register (TAMPID) provides the detection status of each tamper channel. These bits remain active until cleared by software.

A single interrupt request (TAMPER) is available for all tamper channels.

The RTC also supports an input event (TAMPEVT) for generating a tamper condition within the Event System. The tamper input event is enabled by the Tamper Input Event Enable bit in the Event Control register (EVCTRL.TAMPEVEI).

Up to four polarity external inputs (INn) can be used for tamper detection. The polarity for each input is selected with the Tamper Level bits in the Tamper Control register (TAMPCTRL.TAMPLVLn).

# SAM D5x/E5x Family Data Sheet

## RTC – Real-Time Counter

Separate debouncers are embedded for each external input. The debouncer for each input is enabled/disabled with the Debounce Enable bits in the Tamper Control register (TAMPCTRL.DEBNCn). The debouncer configuration is fixed for all inputs as set by the Control B register (CTRLB). The debouncing period duration is configurable using the Debounce Frequency field in the Control B register (CTRLB.DEBF). The period is set for all debouncers (i.e., the duration cannot be adjusted separately for each debouncer).

When TAMPCTRL.DEBNCn = 0, INn is detected asynchronously. See [Figure 21-5](#) for an example.

When TAMPCTRL.DEBNCn = 1, the detection time depends on whether the debouncer operates synchronously or asynchronously, and whether majority detection is enabled or not. Refer to the table below for more details. Synchronous versus asynchronous stability debouncing is configured by the Debounce Asynchronous Enable bit in the Control B register (CTRLB.DEBASYNC):

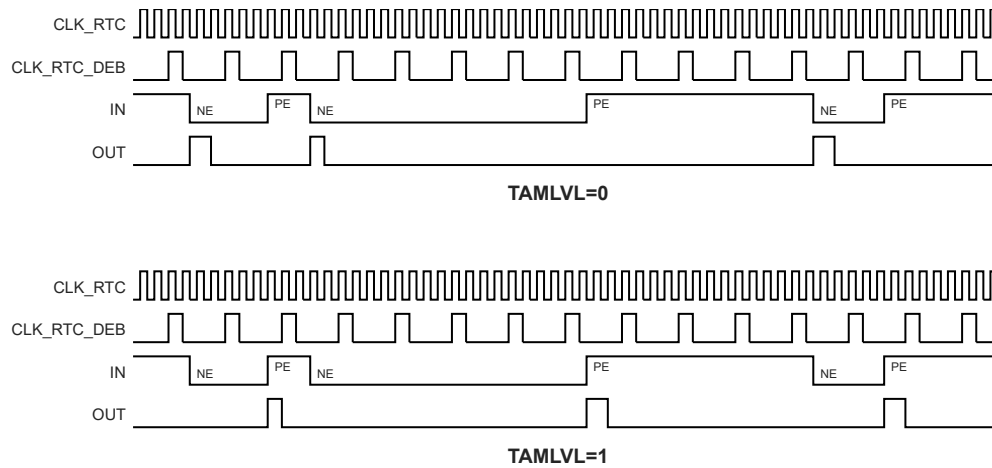
- Synchronous (CTRLB.DEBASYNC = 0): INn is synchronized in two CLK\_RTC periods and then must remain stable for four CLK\_RTC\_DEB periods before a valid detection occurs. See [Figure 21-6](#) for an example.
- Asynchronous (CTRLB.DEBASYNC = 1): The first edge on INn is detected. Further detection is blanked until INn remains stable for four CLK\_RTC\_DEB periods. See [Figure 21-7](#) for an example.

Majority debouncing is configured by the Debounce Majority Enable bit in the Control B register (CTRLB.DEBMAJ). INn must be valid for two out of three CLK\_RTC\_DEB periods. See [Figure 21-8](#) for an example.

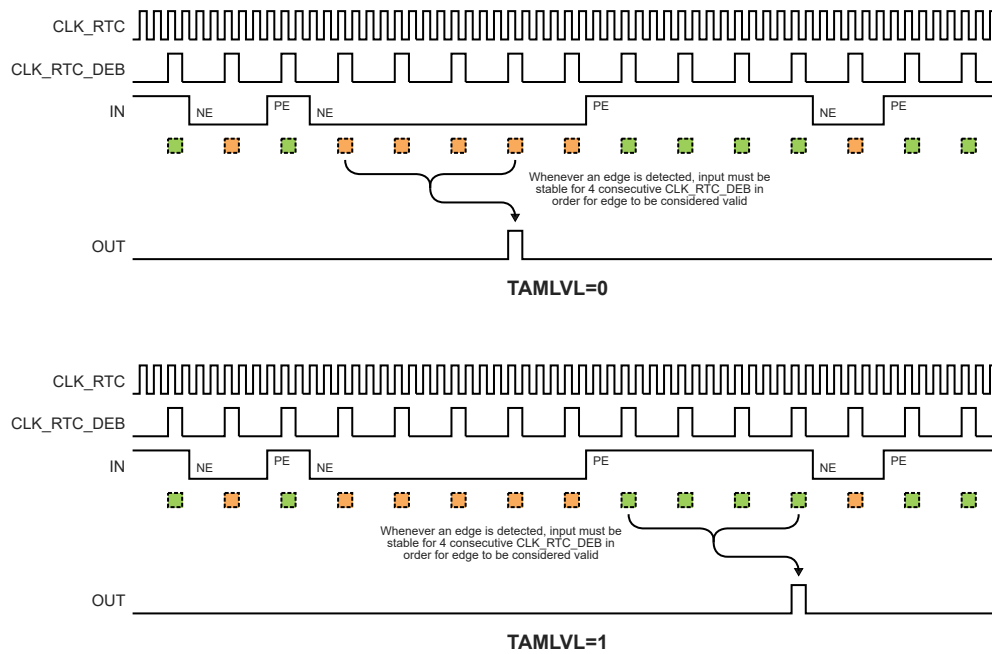
**Table 21-3. Debouncer Configuration**

TAMPCTRL.DEBNCn	CTRLB.DEBMAJ	CTRLB.DEBASYNC	Description
0	X	X	Detect edge on INn with no debouncing. Every edge detected is immediately triggered.
1	0	0	Detect edge on INn with synchronous stability debouncing. Edge detected is only triggered when INn is stable for 4 consecutive CLK_RTC_DEB periods.
1	0	1	Detect edge on INn with asynchronous stability debouncing. First detected edge is triggered immediately. All subsequent detected edges are ignored until INn is stable for 4 consecutive CLK_RTC_DEB periods.
1	1	X	Detect edge on INn with majority debouncing. Pin INn is sampled for 3 consecutive CLK_RTC_DEB periods. Signal level is determined by majority-rule (LLL, LLH, LHL, HLL = '0' and LHH, HLH, HHL, HHH = '1').

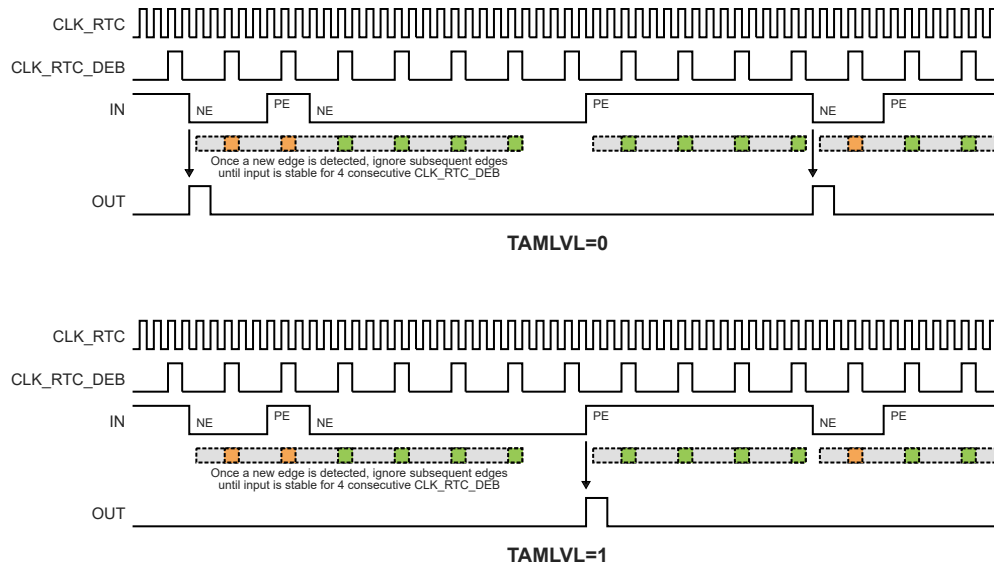
**Figure 21-5. Edge Detection with Debouncer Disabled**



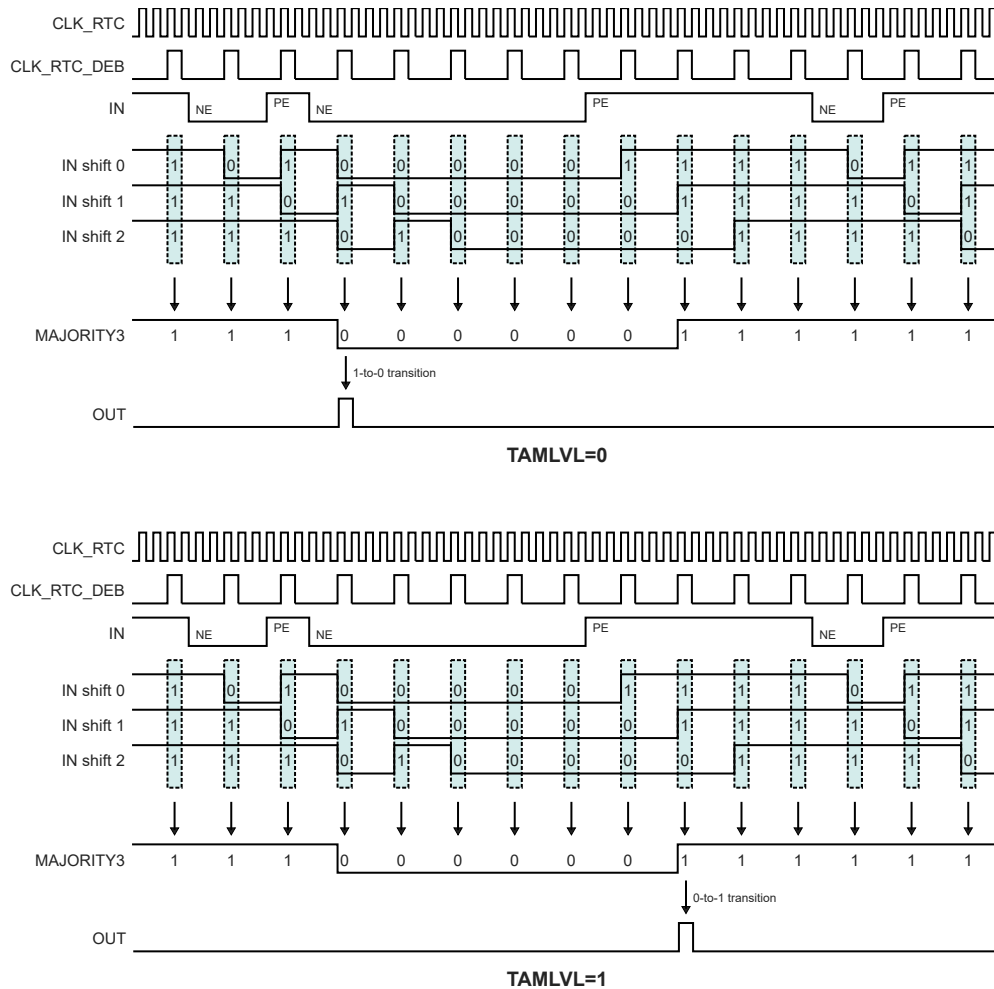
**Figure 21-6. Edge Detection with Synchronous Stability Debouncing**



**Figure 21-7. Edge Detection with Asynchronous Stability Debouncing**



**Figure 21-8. Edge Detection with Majority Debouncing**





**Related Links**[21.3 Block Diagram](#)[21.6.8.5.1 Timestamp](#)[21.6.8.5.2 Active Layer Protection](#)**21.6.8.5.1 Timestamp**

As part of tamper detection the RTC can capture the counter value (COUNT/CLOCK) into the TIMESTAMP register. Three CLK\_RTC periods are required to detect the tampering condition and capture the value. The TIMESTAMP value can be read once the Tamper flag in the Interrupt Flag register (INTFLAG.TAMPER) is set. If the DMA Enable bit in the Control B register (CTRLB.DMAEN) is '1', a DMA request will be triggered by the timestamp. In order to determine which tamper source caused a capture, the Tamper ID register (TAMPID) provides the detection status of each tamper channel and the tamper input event. A DMA transfer can then read both TIMESTAMP and TAMPID in succession.

A new timestamp value cannot be captured until the Tamper flag is cleared, either by reading the timestamp or by writing a '1' to INTFLAG.TAMPER. If several tamper conditions occur in a short window before the flag is cleared, only the first timestamp may be logged. However, the detection of each tamper will still be recorded in TAMPID.

The Tamper Input Event (TAMPEVT) will always perform a timestamp capture. To capture on the external inputs (INn), the corresponding Input Action field in the Tamper Control register (TAMPCTRL.INnACT) must be written to '1'. If an input is set for wake functionality it does not capture the timestamp; however the Tamper flag and TAMPID will still be updated.

**Related Links**[21.6.8.5 Tamper Detection](#)**21.6.8.5.2 Active Layer Protection**

The RTC provides a mean of detecting broken traces on the PCB, also known as Active layer Protection. In this mode, a generated internal RTC signal can be directly routed over critical components on the board using RTC OUT output pin to one RTC INn input pin. A tamper condition is detected if there is a mismatch on the generated RTC signal.

The Active Layer Protection mode and the generation of the RTC signal is enabled by setting the RTCOUT bit in the Control B register (CTRLB.RTCOUT).

Enabling active layer protection requires the following steps:

- Enable the RTC prescaler output by writing a one to the RTC Out bit in the Control B register (CTRLB.RTCOUT). The I/O pins must also be configured to correctly route the signal to the external pins.
- Select the frequency of the output signal by configuring the RTC Active Layer Frequency field in the Control B register (CTRLB.ACTF).

$$GCLK\_RTC\_OUT = \frac{CLK\_RTC}{2^{CTRLB.ACTF + 1}}$$

- Enable the tamper input n (INn) in active layer mode by writing 3 to the corresponding Input Action field in the Tamper Control register (TAMPCTRL.INnACT). When active layer protection is enabled and INn and OUTn pin are used, the value of INn is sampled on the falling edge of CLK\_RTC and compared to the expected value of OUTn. Therefore up to one half of a CLK\_RTC period is available for propagation delay through the trace.
- Enable Active Layer Protection by setting CTRLB.RTCOUT bit.

**Related Links**

21.6.8.5 Tamper Detection

# SAM D5x/E5x Family Data Sheet

## RTC – Real-Time Counter

### 21.7 Register Summary - Mode 0 - 32-Bit Counter

Offset	Name	Bit Pos.									
0x00	CTRLA	7:0	MATCHCLR				MODE[1:0]		ENABLE	SWRST	
		15:8	COUNTSYNC	GPTRST	BKTRST		PRESCALER[3:0]				
0x02	CTRLB	7:0	DMAEN	RTCOUT	DEBASYNC	DEBMAJ			GP2EN	GP0EN	
		15:8		ACTF[2:0]				DEBF[2:0]			
0x04	EVCTRL	7:0	PERE07	PERE06	PERE05	PERE04	PERE03	PERE02	PERE01	PERE00	
		15:8	OVFEO	TAMPEREO					CMPE01	CMPE00	
		23:16								TAMPEVEI	
		31:24									
0x08	INTENCLR	7:0	PER7	PER6	PER5	PER4	PER3	PER2	PER1	PER0	
		15:8	OVF	TAMPER					CMP1	CMP0	
0x0A	INTENSET	7:0	PER7	PER6	PER5	PER4	PER3	PER2	PER1	PER0	
		15:8	OVF	TAMPER					CMP1	CMP0	
0x0C	INTFLAG	7:0	PER7	PER6	PER5	PER4	PER3	PER2	PER1	PER0	
		15:8	OVF	TAMPER					CMP1	CMP0	
0x0E	DBGCTRL	7:0								DBGRUN	
0x0F	Reserved										
0x10	SYNCBUSY	7:0		COMP1	COMP0		COUNT	FREQCORR	ENABLE	SWRST	
		15:8	COUNTSYNC								
		23:16					GP3	GP2	GP1	GP0	
		31:24									
0x14	FREQCORR	7:0	SIGN	VALUE[6:0]							
0x15 ... 0x17	Reserved										
0x18	COUNT	7:0	COUNT[7:0]								
		15:8	COUNT[15:8]								
		23:16	COUNT[23:16]								
		31:24	COUNT[31:24]								
0x1C ... 0x1F	Reserved										
0x20	COMP0	7:0	COMP[7:0]								
		15:8	COMP[15:8]								
		23:16	COMP[23:16]								
		31:24	COMP[31:24]								
0x24	COMP1	7:0	COMP[7:0]								
		15:8	COMP[15:8]								
		23:16	COMP[23:16]								
		31:24	COMP[31:24]								
0x28 ... 0x3F	Reserved										

# SAM D5x/E5x Family Data Sheet

## RTC – Real-Time Counter

.....continued											
Offset	Name	Bit Pos.									
0x40	GP0	7:0	GP[7:0]								
		15:8	GP[15:8]								
		23:16	GP[23:16]								
		31:24	GP[31:24]								
0x44	GP1	7:0	GP[7:0]								
		15:8	GP[15:8]								
		23:16	GP[23:16]								
		31:24	GP[31:24]								
0x48	GP2	7:0	GP[7:0]								
		15:8	GP[15:8]								
		23:16	GP[23:16]								
		31:24	GP[31:24]								
0x4C	GP3	7:0	GP[7:0]								
		15:8	GP[15:8]								
		23:16	GP[23:16]								
		31:24	GP[31:24]								
0x50 ... 0x5F	Reserved										
0x60	TAMPCTRL	7:0	IN3ACT[1:0]		IN2ACT[1:0]		IN1ACT[1:0]		IN0ACT[1:0]		
		15:8								IN4ACT[1:0]	
		23:16				TAMLVL4	TAMLVL3	TAMLVL2	TAMLVL1	TAMLVL0	
		31:24				DEBNC4	DEBNC3	DEBNC2	DEBNC1	DEBNC0	
0x64	TIMESTAMP	7:0	COUNT[7:0]								
		15:8	COUNT[15:8]								
		23:16	COUNT[23:16]								
		31:24	COUNT[31:24]								
0x68	TAMPID	7:0				TAMPID4	TAMPID3	TAMPID2	TAMPID1	TAMPID0	
		15:8									
		23:16									
		31:24	TAMPEVT								
0x6C ... 0x7F	Reserved										
0x80	BKUP0	7:0	BKUP[7:0]								
		15:8	BKUP[15:8]								
		23:16	BKUP[23:16]								
		31:24	BKUP[31:24]								
0x84	BKUP1	7:0	BKUP[7:0]								
		15:8	BKUP[15:8]								
		23:16	BKUP[23:16]								
		31:24	BKUP[31:24]								

# SAM D5x/E5x Family Data Sheet

## RTC – Real-Time Counter

.....continued

Offset	Name	Bit Pos.							
0x88	BKUP2	7:0	BKUP[7:0]						
		15:8	BKUP[15:8]						
		23:16	BKUP[23:16]						
		31:24	BKUP[31:24]						
0x8C	BKUP3	7:0	BKUP[7:0]						
		15:8	BKUP[15:8]						
		23:16	BKUP[23:16]						
		31:24	BKUP[31:24]						
0x90	BKUP4	7:0	BKUP[7:0]						
		15:8	BKUP[15:8]						
		23:16	BKUP[23:16]						
		31:24	BKUP[31:24]						
0x94	BKUP5	7:0	BKUP[7:0]						
		15:8	BKUP[15:8]						
		23:16	BKUP[23:16]						
		31:24	BKUP[31:24]						
0x98	BKUP6	7:0	BKUP[7:0]						
		15:8	BKUP[15:8]						
		23:16	BKUP[23:16]						
		31:24	BKUP[31:24]						
0x9C	BKUP7	7:0	BKUP[7:0]						
		15:8	BKUP[15:8]						
		23:16	BKUP[23:16]						
		31:24	BKUP[31:24]						

### 21.8 Register Description - Mode 0 - 32-Bit Counter

This Register Description section is valid if the RTC is in COUNT32 mode (CTRLA.MODE=0).

Registers can be 8, 16, or 32 bits wide. Atomic 8-, 16-, and 32-bit accesses are supported. In addition, the 8-bit quarters and 16-bit halves of a 32-bit register, and the 8-bit halves of a 16-bit register can be accessed directly.

Some registers require synchronization when read and/or written. Synchronization is denoted by the "Read-Synchronized" and/or "Write-Synchronized" property in each individual register description.

Optional write protection by the Peripheral Access Controller (PAC) is denoted by the "PAC Write Protection" property in each individual register description.

Some registers are enable-protected, meaning they can only be written when the module is disabled. Enable protection is denoted by the "Enable-Protected" property in each individual register description.

### 21.8.1 Control A in COUNT32 mode (CTRLA.MODE=0)

**Name:** CTRLA  
**Offset:** 0x00  
**Reset:** 0x0000  
**Property:** PAC Write-Protection, Enable-Protected, Write-Synchronized

	Bit	15	14	13	12	11	10	9	8
		COUNTSYNC	GPTRST	BKTRST			PRESCALER[3:0]		
Access		R/W	R/W	R/W		R/W	R/W	R/W	R/W
Reset		0	0	0		0	0	0	0
	Bit	7	6	5	4	3	2	1	0
		MATCHCLR				MODE[1:0]		ENABLE	SWRST
Access		R/W				R/W	R/W	R/W	R/W
Reset		0				0	0	0	0

**Bit 15 – COUNTSYNC** COUNT Read Synchronization Enable

The COUNT register requires synchronization when reading. Disabling the synchronization will prevent reading valid values from the COUNT register.

This bit is not enable-protected.

Value	Description
0	COUNT read synchronization is disabled
1	COUNT read synchronization is enabled

**Bit 14 – GPTRST** GP Registers Reset On Tamper Enable

Only GP registers enabled by the CTRLB.GPnEN bits are affected. This bit can be written only when the peripheral is disabled.

This bit is not synchronized.

**Bit 13 – BKTRST** BKUP Registers Reset On Tamper Enable

All BKUPn registers are affected. This bit can be written only when the peripheral is disabled.

This bit is not synchronized.

Value	Description
0	BKUPn registers will not reset when a tamper condition occurs.
1	BKUPn registers will reset when a tamper condition occurs.

**Bits 11:8 – PRESCALER[3:0]** Prescaler

These bits define the prescaling factor for the RTC clock source (GCLK\_RTC) to generate the counter clock (CLK\_RTC\_CNT). Periodic events and interrupts are not available when the prescaler is off. These bits are not synchronized.

Value	Name	Description
0x0	OFF	CLK_RTC_CNT = GCLK_RTC/1
0x1	DIV1	CLK_RTC_CNT = GCLK_RTC/1
0x2	DIV2	CLK_RTC_CNT = GCLK_RTC/2
0x3	DIV4	CLK_RTC_CNT = GCLK_RTC/4
0x4	DIV8	CLK_RTC_CNT = GCLK_RTC/8
0x5	DIV16	CLK_RTC_CNT = GCLK_RTC/16

Value	Name	Description
0x6	DIV32	CLK_RTC_CNT = GCLK_RTC/32
0x7	DIV64	CLK_RTC_CNT = GCLK_RTC/64
0x8	DIV128	CLK_RTC_CNT = GCLK_RTC/128
0x9	DIV256	CLK_RTC_CNT = GCLK_RTC/256
0xA	DIV512	CLK_RTC_CNT = GCLK_RTC/512
0xB	DIV1024	CLK_RTC_CNT = GCLK_RTC/1024
0xC–0xF	-	Reserved

### Bit 7 – MATCHCLR Clear on Match

This bit defines if the counter is cleared or not on a match.

This bit is not synchronized.

Value	Description
0	The counter is not cleared on a Compare/Alarm 0 match
1	The counter is cleared on a Compare/Alarm 0 match

### Bits 3:2 – MODE[1:0] Operating Mode

This bit group defines the operating mode of the RTC.

This bit is not synchronized.

Value	Name	Description
0x0	COUNT32	Mode 0: 32-bit counter
0x1	COUNT16	Mode 1: 16-bit counter
0x2	CLOCK	Mode 2: Clock/calendar
0x3	-	Reserved

### Bit 1 – ENABLE Enable

Due to synchronization there is a delay between writing CTRLA.ENABLE and until the peripheral is enabled/disabled. The value written to CTRLA.ENABLE will read back immediately and the Enable bit in the Synchronization Busy register (SYNCBUSY.ENABLE) will be set. SYNCBUSY.ENABLE will be cleared when the operation is complete.

Value	Description
0	The peripheral is disabled
1	The peripheral is enabled

### Bit 0 – SWRST Software Reset

Writing a '0' to this bit has no effect.

Writing a '1' to this bit resets all registers in the RTC (except DBGCTRL) to their initial state, and the RTC will be disabled.

Writing a '1' to CTRLA.SWRST will always take precedence, meaning that all other writes in the same write-operation will be discarded.

Due to synchronization there is a delay between writing CTRLA.SWRST and until the reset is complete. CTRLA.SWRST will be cleared when the reset is complete.

Value	Description
0	There is not reset operation ongoing
1	The reset operation is ongoing

### 21.8.2 Control B in COUNT32 mode (CTRLA.MODE=0)

**Name:** CTRLB  
**Offset:** 0x02  
**Reset:** 0x0000  
**Property:** PAC Write-Protection, Enable-Protected

	Bit	15	14	13	12	11	10	9	8
		ACTF[2:0]					DEBF[2:0]		
Access		R/W	R/W	R/W		R/W	R/W	R/W	
Reset		0	0	0		0	0	0	
	Bit	7	6	5	4	3	2	1	0
		DMAEN	RTCOUT	DEBASYNC	DEBMAJ			GP2EN	GP0EN
Access		R/W	R/W	R/W	R/W			R/W	R/W
Reset		0	0	0	0			0	0

#### Bits 14:12 – ACTF[2:0] Active Layer Frequency

These bits define the prescaling factor for the RTC clock output (OUT) used during active layer protection in terms of the CLK\_RTC.

Value	Name	Description
0x0	DIV2	CLK_RTC_OUT = CLK_RTC / 2
0x1	DIV4	CLK_RTC_OUT = CLK_RTC / 4
0x2	DIV8	CLK_RTC_OUT = CLK_RTC / 8
0x3	DIV16	CLK_RTC_OUT = CLK_RTC / 16
0x4	DIV32	CLK_RTC_OUT = CLK_RTC / 32
0x5	DIV64	CLK_RTC_OUT = CLK_RTC / 64
0x6	DIV128	CLK_RTC_OUT = CLK_RTC / 128
0x7	DIV256	CLK_RTC_OUT = CLK_RTC / 256

#### Bits 10:8 – DEBF[2:0] Debounce Frequency

These bits define the prescaling factor for the input debouncers in terms of the CLK\_RTC.

Value	Name	Description
0x0	DIV2	CLK_RTC_DEB = CLK_RTC / 2
0x1	DIV4	CLK_RTC_DEB = CLK_RTC / 4
0x2	DIV8	CLK_RTC_DEB = CLK_RTC / 8
0x3	DIV16	CLK_RTC_DEB = CLK_RTC / 16
0x4	DIV32	CLK_RTC_DEB = CLK_RTC / 32
0x5	DIV64	CLK_RTC_DEB = CLK_RTC / 64
0x6	DIV128	CLK_RTC_DEB = CLK_RTC / 128
0x7	DIV256	CLK_RTC_DEB = CLK_RTC / 256

#### Bit 7 – DMAEN DMA Enable

The RTC can trigger a DMA request when the timestamp is ready in the TIMESTAMP register.

Value	Description
0	Tamper DMA request is disabled. Reading TIMESTAMP has no effect on INTFLAG.TAMPER.
1	Tamper DMA request is enabled. Reading TIMESTAMP will clear INTFLAG.TAMPER.



---



---

**Bit 6 – RTCOUT** RTC Output Enable

Value	Description
0	The RTC active layer output is disabled.
1	The RTC active layer output is enabled.

**Bit 5 – DEBASYNC** Debouncer Asynchronous Enable

Value	Description
0	The tamper input debouncers operate synchronously.
1	The tamper input debouncers operate asynchronously.

**Bit 4 – DEBMAJ** Debouncer Majority Enable

Value	Description
0	The tamper input debouncers match three equal values.
1	The tamper input debouncers match majority two of three values.

**Bit 1 – GP2EN** General Purpose 2 Enable

Value	Description
0	COMP1 compare function enabled. GP2/GP3 disabled.
1	COMP1 compare function disabled. GP2/GP3 enabled.

**Bit 0 – GP0EN** General Purpose 0 Enable

Value	Description
0	COMP0 compare function enabled. GP0/GP1 disabled.
1	COMP0 compare function disabled. GP0/GP1 enabled.

### 21.8.3 Event Control in COUNT32 mode (CTRLA.MODE=0)

**Name:** EVCTRL  
**Offset:** 0x04  
**Reset:** 0x00000000  
**Property:** PAC Write-Protection, Enable-Protected

	31	30	29	28	27	26	25	24
Access								
Reset								
	23	22	21	20	19	18	17	16
Access								TAMPEVEI
Reset								0
	15	14	13	12	11	10	9	8
Access	OVFEO	TAMPEREO					CMPEO1	CMPEO0
Reset	0	0					0	0
	7	6	5	4	3	2	1	0
Access	PEREO7	PEREO6	PEREO5	PEREO4	PEREO3	PEREO2	PEREO1	PEREO0
Reset	0	0	0	0	0	0	0	0

#### Bit 16 – TAMPEVEI Tamper Event Input Enable

Value	Description
0	Tamper event input is disabled and incoming events will be ignored.
1	Tamper event input is enabled and incoming events will capture the COUNT value.

#### Bit 15 – OVFE0 Overflow Event Output Enable

Value	Description
0	Overflow event is disabled and will not be generated.
1	Overflow event is enabled and will be generated for every overflow.

#### Bit 14 – TAMPEREO Tamper Event Output Enable

Value	Description
0	Tamper event output is disabled and will not be generated.
1	Tamper event output is enabled and will be generated for every tamper input.

#### Bits 8, 9 – CMPEOn Compare n Event Output Enable [n = 1..0]

Value	Description
0	Compare n event is disabled and will not be generated.
1	Compare n event is enabled and will be generated for every compare match.

#### Bits 0, 1, 2, 3, 4, 5, 6, 7 – PEREOn Periodic Interval n Event Output Enable [n = 7..0]

# SAM D5x/E5x Family Data Sheet

## RTC – Real-Time Counter

---

---

Value	Description
0	Periodic Interval n event is disabled and will not be generated.
1	Periodic Interval n event is enabled and will be generated.

### 21.8.4 Interrupt Enable Clear in COUNT32 mode (CTRLA.MODE=0)

**Name:** INTENCLR  
**Offset:** 0x08  
**Reset:** 0x0000  
**Property:** PAC Write-Protection

This register allows the user to disable an interrupt without doing a read-modify-write operation. Changes in this register will also be reflected in the Interrupt Enable Set (INTENSET) register.

Bit	15	14	13	12	11	10	9	8
	OVF	TAMPER					CMP1	CMP0
Access	R/W	R/W					R/W	R/W
Reset	0	0					0	0
Bit	7	6	5	4	3	2	1	0
	PER7	PER6	PER5	PER4	PER3	PER2	PER1	PER0
Access	R/W	R/W	R/W	R/W	R/W	R/W	R/W	R/W
Reset	0	0	0	0	0	0	0	0

#### Bit 15 – OVF Overflow Interrupt Enable

Writing a '0' to this bit has no effect.

Writing a '1' to this bit will clear the Overflow Interrupt Enable bit, which disables the Overflow interrupt.

Value	Description
0	The Overflow interrupt is disabled.
1	The Overflow interrupt is enabled.

#### Bit 14 – TAMPER Tamper Interrupt Enable

Writing a '0' to this bit has no effect.

Writing a '1' to this bit will clear the Tamper Interrupt Enable bit, which disables the Tamper interrupt.

Value	Description
0	The Tamper interrupt is disabled.
1	The Tamper interrupt is enabled.

#### Bits 8, 9 – CMPn Compare n Interrupt Enable [n = 1..0]

Writing a '0' to this bit has no effect.

Writing a '1' to this bit will clear the Compare n Interrupt Enable bit, which disables the Compare n interrupt.

Value	Description
0	The Compare n interrupt is disabled.
1	The Compare n interrupt is enabled.

#### Bits 0, 1, 2, 3, 4, 5, 6, 7 – PERn Periodic Interval n Interrupt Enable [n = 7..0]

Writing a '0' to this bit has no effect.

Writing a '1' to this bit will clear the Periodic Interval n Interrupt Enable bit, which disables the Periodic Interval n interrupt.

Value	Description
0	Periodic Interval n interrupt is disabled.
1	Periodic Interval n interrupt is enabled.

### 21.8.5 Interrupt Enable Set in COUNT32 mode (CTRLA.MODE=0)

**Name:** INTENSET  
**Offset:** 0x0A  
**Reset:** 0x0000  
**Property:** PAC Write-Protection

This register allows the user to enable an interrupt without doing a read-modify-write operation. Changes in this register will also be reflected in the Interrupt Enable Clear (INTENCLR) register.

Bit	15	14	13	12	11	10	9	8
	OVF	TAMPER					CMP1	CMP0
Access	R/W	R/W					R/W	R/W
Reset	0	0					0	0
Bit	7	6	5	4	3	2	1	0
	PER7	PER6	PER5	PER4	PER3	PER2	PER1	PER0
Access	R/W	R/W	R/W	R/W	R/W	R/W	R/W	R/W
Reset	0	0	0	0	0	0	0	0

#### Bit 15 – OVF Overflow Interrupt Enable

Writing a '0' to this bit has no effect.

Writing a '1' to this bit will set the Overflow Interrupt Enable bit, which enables the Overflow interrupt.

Value	Description
0	The Overflow interrupt is disabled.
1	The Overflow interrupt is enabled.

#### Bit 14 – TAMPER Tamper Interrupt Enable

Writing a '0' to this bit has no effect.

Writing a '1' to this bit will set the Tamper Interrupt Enable bit, which enables the Tamper interrupt.

Value	Description
0	The Tamper interrupt is disabled.
1	The Tamper interrupt is enabled.

#### Bits 8, 9 – CMPn Compare n Interrupt Enable [n = 1..0]

Writing a '0' to this bit has no effect.

Writing a '1' to this bit will set the Compare n Interrupt Enable bit, which and enables the Compare n interrupt.

Value	Description
0	The Compare n interrupt is disabled.
1	The Compare n interrupt is enabled.

#### Bits 0, 1, 2, 3, 4, 5, 6, 7 – PERn Periodic Interval n Interrupt Enable [n = 7..0]

Writing a '0' to this bit has no effect.

Writing a '1' to this bit will set the Periodic Interval n Interrupt Enable bit, which enables the Periodic Interval n interrupt.

Value	Description
0	Periodic Interval n interrupt is disabled.
1	Periodic Interval n interrupt is enabled.

### 21.8.6 Interrupt Flag Status and Clear in COUNT32 mode (CTRLA.MODE=0)

**Name:** INTFLAG  
**Offset:** 0x0C  
**Reset:** 0x0000  
**Property:** -

	Bit	15	14	13	12	11	10	9	8
		OVF	TAMPER					CMP1	CMP0
Access		R/W	R/W					R/W	R/W
Reset		0	0					0	0
	Bit	7	6	5	4	3	2	1	0
		PER7	PER6	PER5	PER4	PER3	PER2	PER1	PER0
Access		R/W	R/W	R/W	R/W	R/W	R/W	R/W	R/W
Reset		0	0	0	0	0	0	0	0

**Bit 15 – OVF** Overflow

This flag is cleared by writing a '1' to the flag.  
 This flag is set on the next CLK\_RTC\_CNT cycle after an overflow condition occurs, and an interrupt request will be generated if INTENCLR/SET.OVF is '1'.  
 Writing a '0' to this bit has no effect.  
 Writing a '1' to this bit clears the Overflow interrupt flag.

**Bit 14 – TAMPER** Tamper event

This flag is set after a damper condition occurs, and an interrupt request will be generated if INTENCLR.TAMPER/INTENSET.TAMPER is '1'. Writing a '0' to this bit has no effect. Writing a '1' to this bit clears the Tamper interrupt flag.

**Bits 8, 9 – CMPn** Compare n [n = 1..0]

This flag is cleared by writing a '1' to the flag.  
 This flag is set on the next CLK\_RTC\_CNT cycle after a match with the compare condition, and an interrupt request will be generated if INTENCLR/SET.COMPn is one.  
 Writing a '0' to this bit has no effect.  
 Writing a '1' to this bit clears the Compare n interrupt flag.

**Bits 0, 1, 2, 3, 4, 5, 6, 7 – PERn** Periodic Interval n [n = 7..0]

This flag is cleared by writing a '1' to the flag.  
 This flag is set on the 0-to-1 transition of prescaler bit [n+2], and an interrupt request will be generated if INTENCLR/SET.PERn is one.  
 Writing a '0' to this bit has no effect.  
 Writing a '1' to this bit clears the Periodic Interval n interrupt flag.

### 21.8.7 Debug Control

**Name:** DBGCTRL  
**Offset:** 0x0E  
**Reset:** 0x00  
**Property:** PAC Write-Protection

	7	6	5	4	3	2	1	0
								DBGRUN
Access								R/W
Reset								0

#### Bit 0 – DBGRUN Debug Run

This bit is not reset by a software reset.

This bit controls the functionality when the CPU is halted by an external debugger.

Value	Description
0	The RTC is halted when the CPU is halted by an external debugger.
1	The RTC continues normal operation when the CPU is halted by an external debugger.

### 21.8.8 Synchronization Busy in COUNT32 mode (CTRLA.MODE=0)

**Name:** SYNCBUSY  
**Offset:** 0x10  
**Reset:** 0x00000000  
**Property:** -

Bit	31	30	29	28	27	26	25	24
Access								
Reset								
Bit	23	22	21	20	19	18	17	16
					GP3	GP2	GP1	GP0
Access					R	R	R	R
Reset					0	0	0	0
Bit	15	14	13	12	11	10	9	8
	COUNTSYNC							
Access	R							
Reset	0							
Bit	7	6	5	4	3	2	1	0
		COMP1	COMP0		COUNT	FREQCORR	ENABLE	SWRST
Access		R	R		R	R	R	R
Reset		0	0		0	0	0	0

#### Bits 16, 17, 18, 19 – Gp<sub>n</sub> General Purpose n Synchronization Busy Status

Value	Description
0	Write synchronization for Gp <sub>n</sub> register is complete.
1	Write synchronization for Gp <sub>n</sub> register is ongoing.

#### Bit 15 – COUNTSYNC Count Read Sync Enable Synchronization Busy Status

Value	Description
0	Write synchronization for CTRLA.COUNTSYNC bit is complete.
1	Write synchronization for CTRLA.COUNTSYNC bit is ongoing.

#### Bits 5, 6 – COMP<sub>n</sub> Compare n Synchronization Busy Status [n = 1..0]

Value	Description
0	Write synchronization for COMP <sub>x</sub> register is complete.
1	Write synchronization for COMP <sub>x</sub> register is ongoing.

#### Bit 3 – COUNT Count Value Synchronization Busy Status

Value	Description
0	Read/write synchronization for COUNT register is complete.
1	Read/write synchronization for COUNT register is ongoing.

#### Bit 2 – FREQCORR Frequency Correction Synchronization Busy Status



---

---

Value	Description
0	Write synchronization for FREQCORR register is complete.
1	Write synchronization for FREQCORR register is ongoing.

**Bit 1 – ENABLE** Enable Synchronization Busy Status

Value	Description
0	Write synchronization for CTRLA.ENABLE bit is complete.
1	Write synchronization for CTRLA.ENABLE bit is ongoing.

**Bit 0 – SWRST** Software Reset Synchronization Busy Status

Value	Description
0	Write synchronization for CTRLA.SWRST bit is complete.
1	Write synchronization for CTRLA.SWRST bit is ongoing.

### 21.8.9 Frequency Correction

**Name:**       FREQCORR  
**Offset:**     0x14  
**Reset:**       0x00  
**Property:**   PAC Write-Protection, Write-Synchronized

	7	6	5	4	3	2	1	0
	SIGN	VALUE[6:0]						
Access	R/W	R/W	R/W	R/W	R/W	R/W	R/W	R/W
Reset	0	0	0	0	0	0	0	0

#### Bit 7 – SIGN Correction Sign

Value	Description
0	The correction value is positive, i.e., frequency will be decreased.
1	The correction value is negative, i.e., frequency will be increased.

#### Bits 6:0 – VALUE[6:0] Correction Value

These bits define the amount of correction applied to the RTC prescaler.

Value	Description
0	Correction is disabled and the RTC frequency is unchanged.
1 – 127	The RTC frequency is adjusted according to the value.

# SAM D5x/E5x Family Data Sheet

## RTC – Real-Time Counter

### 21.8.10 Counter Value in COUNT32 mode (CTRLA.MODE=0)

**Name:** COUNT  
**Offset:** 0x18  
**Reset:** 0x00000000  
**Property:** PAC Write-Protection, Write-Synchronized, Read-Synchronized

Bit	31	30	29	28	27	26	25	24
COUNT[31:24]								
Access	R/W	R/W	R/W	R/W	R/W	R/W	R/W	R/W
Reset	0	0	0	0	0	0	0	0
Bit	23	22	21	20	19	18	17	16
COUNT[23:16]								
Access	R/W	R/W	R/W	R/W	R/W	R/W	R/W	R/W
Reset	0	0	0	0	0	0	0	0
Bit	15	14	13	12	11	10	9	8
COUNT[15:8]								
Access	R/W	R/W	R/W	R/W	R/W	R/W	R/W	R/W
Reset	0	0	0	0	0	0	0	0
Bit	7	6	5	4	3	2	1	0
COUNT[7:0]								
Access	R/W	R/W	R/W	R/W	R/W	R/W	R/W	R/W
Reset	0	0	0	0	0	0	0	0

#### Bits 31:0 – COUNT[31:0] Counter Value

These bits define the value of the 32-bit RTC counter in mode 0.

# SAM D5x/E5x Family Data Sheet

## RTC – Real-Time Counter

### 21.8.11 Compare n Value in COUNT32 mode (CTRLA.MODE=0)

**Name:** COMP  
**Offset:** 0x20 + n\*0x04 [n=0..1]  
**Reset:** 0x00000000  
**Property:** PAC Write-Protection, Write-Synchronized

Bit	31	30	29	28	27	26	25	24
COMP[31:24]								
Access	R/W	R/W	R/W	R/W	R/W	R/W	R/W	R/W
Reset	0	0	0	0	0	0	0	0
Bit	23	22	21	20	19	18	17	16
COMP[23:16]								
Access	R/W	R/W	R/W	R/W	R/W	R/W	R/W	R/W
Reset	0	0	0	0	0	0	0	0
Bit	15	14	13	12	11	10	9	8
COMP[15:8]								
Access	R/W	R/W	R/W	R/W	R/W	R/W	R/W	R/W
Reset	0	0	0	0	0	0	0	0
Bit	7	6	5	4	3	2	1	0
COMP[7:0]								
Access	R/W	R/W	R/W	R/W	R/W	R/W	R/W	R/W
Reset	0	0	0	0	0	0	0	0

#### Bits 31:0 – COMP[31:0] Compare Value

The 32-bit value of COMP<sub>n</sub> is continuously compared with the 32-bit COUNT value. When a match occurs, the Compare n interrupt flag in the Interrupt Flag Status and Clear register (INTFLAG.COMP<sub>n</sub>) is set on the next counter cycle, and the counter value is cleared if CTRLA.MATCHCLR is one.

# SAM D5x/E5x Family Data Sheet

## RTC – Real-Time Counter

### 21.8.12 General Purpose n

**Name:** GPn  
**Offset:** 0x40 + n\*0x04 [n=0..3]  
**Reset:** 0x00000000  
**Property:** -

Bit	31	30	29	28	27	26	25	24
	GP[31:24]							
Access	R/W	R/W	R/W	R/W	R/W	R/W	R/W	R/W
Reset	0	0	0	0	0	0	0	0
Bit	23	22	21	20	19	18	17	16
	GP[23:16]							
Access	R/W	R/W	R/W	R/W	R/W	R/W	R/W	R/W
Reset	0	0	0	0	0	0	0	0
Bit	15	14	13	12	11	10	9	8
	GP[15:8]							
Access	R/W	R/W	R/W	R/W	R/W	R/W	R/W	R/W
Reset	0	0	0	0	0	0	0	0
Bit	7	6	5	4	3	2	1	0
	GP[7:0]							
Access	R/W	R/W	R/W	R/W	R/W	R/W	R/W	R/W
Reset	0	0	0	0	0	0	0	0

#### Bits 31:0 – GP[31:0] General Purpose

These bits are for user-defined general purpose use, see [21.6.8.4 General Purpose Registers](#).

# SAM D5x/E5x Family Data Sheet

## RTC – Real-Time Counter

### 21.8.13 Tamper Control

**Name:** TAMPCTRL  
**Offset:** 0x60  
**Reset:** 0x00000000  
**Property:** PAC Write-Protection, Enable-Protected

	Bit	31	30	29	28	27	26	25	24
					DEBNC4	DEBNC3	DEBNC2	DEBNC1	DEBNC0
Access									
Reset					0	0	0	0	0
	Bit	23	22	21	20	19	18	17	16
					TAMLVL4	TAMLVL3	TAMLVL2	TAMLVL1	TAMLVL0
Access									
Reset					0	0	0	0	0
	Bit	15	14	13	12	11	10	9	8
								IN4ACT[1:0]	
Access									
Reset								0	0
	Bit	7	6	5	4	3	2	1	0
		IN3ACT[1:0]		IN2ACT[1:0]		IN1ACT[1:0]		IN0ACT[1:0]	
Access									
Reset		0	0	0	0	0	0	0	0

**Bits 24, 25, 26, 27, 28 – DEBNC** Debounce Enable of Tamper Input INn

**Note:** Debounce feature does not apply to the Active Layer Protection mode (TAMPCTRL.INACT = ACTL).

Value	Description
0	Debouncing is disabled for Tamper input INn
1	Debouncing is enabled for Tamper input INn

**Bits 16, 17, 18, 19, 20 – TAMLVL** Tamper Level Select of Tamper Input INn

**Note:** Tamper Level feature does not apply to the Active Layer Protection mode (TAMPCTRL.INACT = ACTL).

Value	Description
0	A falling edge condition will be detected on Tamper input INn.
1	A rising edge condition will be detected on Tamper input INn.

**Bits 0:1, 2:3, 4:5, 6:7, 8:9 – INACT** Tamper Channel n Action

These bits determine the action taken by Tamper Channel n.

Value	Name	Description
0x0	OFF	Off (Disabled)
0x1	WAKE	Wake and set Tamper flag
0x2	CAPTURE	Capture timestamp and set Tamper flag

# SAM D5x/E5x Family Data Sheet

## RTC – Real-Time Counter

---

---

Value	Name	Description
0x3	ACTL	Compare RTC signal routed between INn and OUT pins . When a mismatch occurs, capture timestamp and set Tamper flag

# SAM D5x/E5x Family Data Sheet

## RTC – Real-Time Counter

### 21.8.14 Timestamp

**Name:**       TIMESTAMP  
**Offset:**     0x64  
**Reset:**       0x0  
**Property:**   Read-Only

Bit	31	30	29	28	27	26	25	24
	COUNT[31:24]							
Access	RO	RO	RO	RO	RO	RO	RO	RO
Reset	0	0	0	0	0	0	0	0
Bit	23	22	21	20	19	18	17	16
	COUNT[23:16]							
Access	RO	RO	RO	RO	RO	RO	RO	RO
Reset	0	0	0	0	0	0	0	0
Bit	15	14	13	12	11	10	9	8
	COUNT[15:8]							
Access	RO	RO	RO	RO	RO	RO	RO	RO
Reset	0	0	0	0	0	0	0	0
Bit	7	6	5	4	3	2	1	0
	COUNT[7:0]							
Access	RO	RO	RO	RO	RO	RO	RO	RO
Reset	0	0	0	0	0	0	0	0

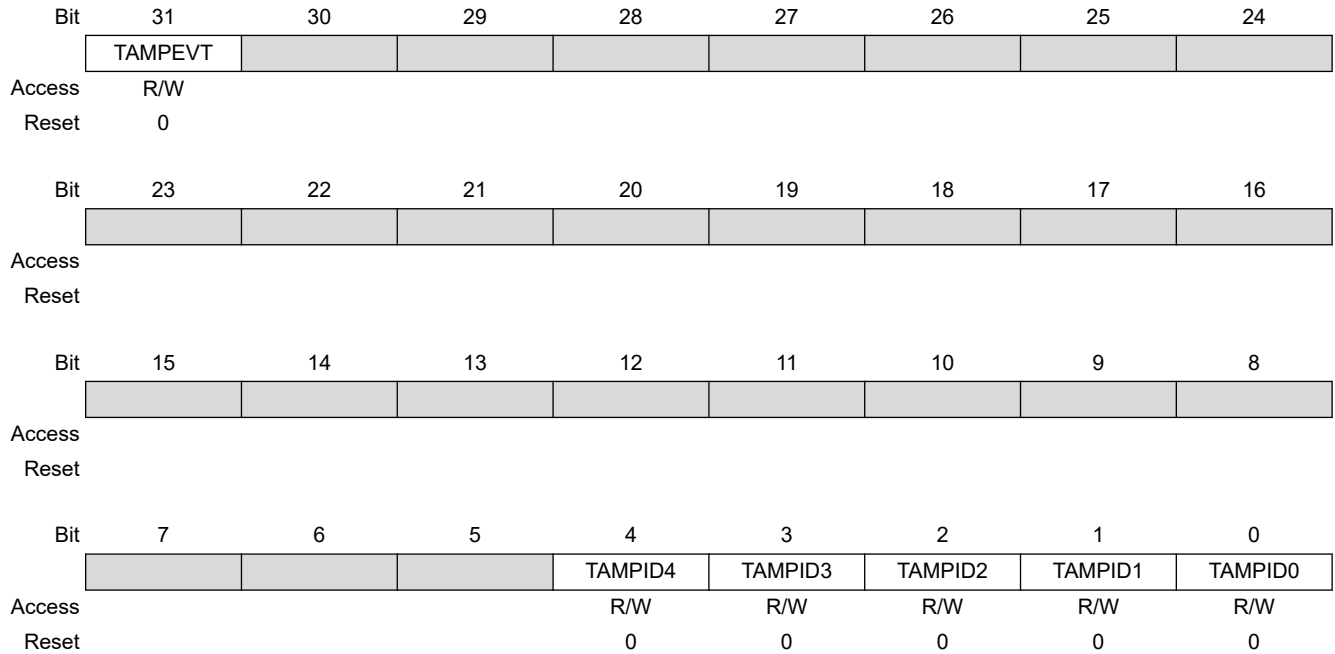
#### Bits 31:0 – COUNT[31:0] Count Timestamp Value

The 32-bit value of COUNT is captured by the TIMESTAMP when a tamper condition occurs



### 21.8.15 Tamper ID

**Name:** TAMPID  
**Offset:** 0x68  
**Reset:** 0x00000000



**Bit 31 – TAMPEVT** Tamper Event Detected

Writing a '0' to this bit has no effect. Writing a '1' to this bit clears the tamper detection bit.

Value	Description
0	A tamper input event has not been detected
1	A tamper input event has been detected

**Bits 0, 1, 2, 3, 4 – TAMPID** Tamper on Channel n Detected

Writing a '0' to this bit has no effect. Writing a '1' to this bit clears the tamper detection bit.

Value	Description
0	A tamper condition has not been detected on Channel n
1	A tamper condition has been detected on Channel n

# SAM D5x/E5x Family Data Sheet

## RTC – Real-Time Counter

### 21.8.16 Backup n

**Name:** BKUP  
**Offset:** 0x80 + n\*0x04 [n=0..7]  
**Reset:** 0x00000000  
**Property:** PAC Write-Protection

Bit	31	30	29	28	27	26	25	24
	BKUP[31:24]							
Access	R/W	R/W	R/W	R/W	R/W	R/W	R/W	R/W
Reset	0	0	0	0	0	0	0	0
Bit	23	22	21	20	19	18	17	16
	BKUP[23:16]							
Access	R/W	R/W	R/W	R/W	R/W	R/W	R/W	R/W
Reset	0	0	0	0	0	0	0	0
Bit	15	14	13	12	11	10	9	8
	BKUP[15:8]							
Access	R/W	R/W	R/W	R/W	R/W	R/W	R/W	R/W
Reset	0	0	0	0	0	0	0	0
Bit	7	6	5	4	3	2	1	0
	BKUP[7:0]							
Access	R/W	R/W	R/W	R/W	R/W	R/W	R/W	R/W
Reset	0	0	0	0	0	0	0	0

#### Bits 31:0 – BKUP[31:0] Backup

These bits are user-defined for general purpose use in the Backup domain.

# SAM D5x/E5x Family Data Sheet

## RTC – Real-Time Counter

### 21.9 Register Summary - Mode 1 - 16-Bit Counter

Offset	Name	Bit Pos.									
0x00	CTRLA	7:0					MODE[1:0]	ENABLE	SWRST		
		15:8	COUNTSYNC	GPTRST	BKTRST		PRESCALER[3:0]				
0x02	CTRLB	7:0	DMAEN	RTCOUT	DEBASYNC	DEBMAJ			GP2EN	GP0EN	
		15:8		ACTF[2:0]				DEBF[2:0]			
0x04	EVCTRL	7:0	PERE07	PERE06	PERE05	PERE04	PERE03	PERE02	PERE01	PERE00	
		15:8	OVFEO	TAMPEREO			CMPEO3	CMPEO2	CMPEO1	CMPEO0	
		23:16								TAMPEVEI	
		31:24									
0x08	INTENCLR	7:0	PER7	PER6	PER5	PER4	PER3	PER2	PER1	PER0	
		15:8	OVF	TAMPER			CMP3	CMP2	CMP1	CMP0	
0x0A	INTENSET	7:0	PER7	PER6	PER5	PER4	PER3	PER2	PER1	PER0	
		15:8	OVF	TAMPER			CMP3	CMP2	CMP1	CMP0	
0x0C	INTFLAG	7:0	PER7	PER6	PER5	PER4	PER3	PER2	PER1	PER0	
		15:8	OVF	TAMPER			CMP3	CMP2	CMP1	CMP0	
0x0E	DBGCTRL	7:0								DBGRUN	
0x0F	Reserved										
0x10	SYNCBUSY	7:0	COMP2	COMP1	COMP0	PER	COUNT	FREQCORR	ENABLE	SWRST	
		15:8	COUNTSYNC							COMP3	
		23:16					GP3	GP2	GP1	GP0	
		31:24									
0x14	FREQCORR	7:0	SIGN	VALUE[6:0]							
0x15 ... 0x17	Reserved										
0x18	COUNT	7:0	COUNT[7:0]								
		15:8	COUNT[15:8]								
0x1A ... 0x1B	Reserved										
0x1C	PER	7:0	PER[7:0]								
		15:8	PER[15:8]								
0x1E ... 0x1F	Reserved										
0x20	COMP0	7:0	COMP[7:0]								
		15:8	COMP[15:8]								
0x22	COMP1	7:0	COMP[7:0]								
		15:8	COMP[15:8]								
0x24	COMP2	7:0	COMP[7:0]								
		15:8	COMP[15:8]								
0x26	COMP3	7:0	COMP[7:0]								
		15:8	COMP[15:8]								

# SAM D5x/E5x Family Data Sheet

## RTC – Real-Time Counter

.....continued

Offset	Name	Bit Pos.								
0x28 ... 0x3F	Reserved									
0x40	GP0	7:0	GP[7:0]							
		15:8	GP[15:8]							
		23:16	GP[23:16]							
		31:24	GP[31:24]							
0x44	GP1	7:0	GP[7:0]							
		15:8	GP[15:8]							
		23:16	GP[23:16]							
		31:24	GP[31:24]							
0x48	GP2	7:0	GP[7:0]							
		15:8	GP[15:8]							
		23:16	GP[23:16]							
		31:24	GP[31:24]							
0x4C	GP3	7:0	GP[7:0]							
		15:8	GP[15:8]							
		23:16	GP[23:16]							
		31:24	GP[31:24]							
0x50 ... 0x5F	Reserved									
0x60	TAMPCTRL	7:0	IN3ACT[1:0]		IN2ACT[1:0]		IN1ACT[1:0]		IN0ACT[1:0]	
		15:8	IN4ACT[1:0]							
		23:16			TAMLVL4	TAMLVL3	TAMLVL2	TAMLVL1	TAMLVL0	
		31:24			DEBNC4	DEBNC3	DEBNC2	DEBNC1	DEBNC0	
0x64	TIMESTAMP	7:0	COUNT[7:0]							
		15:8	COUNT[15:8]							
		23:16								
		31:24								
0x68	TAMPID	7:0			TAMPID4	TAMPID3	TAMPID2	TAMPID1	TAMPID0	
		15:8								
		23:16								
		31:24	TAMPEVT							
0x6C ... 0x7F	Reserved									
0x80	BKUP0	7:0	BKUP[7:0]							
		15:8	BKUP[15:8]							
		23:16	BKUP[23:16]							
		31:24	BKUP[31:24]							
0x84	BKUP1	7:0	BKUP[7:0]							
		15:8	BKUP[15:8]							
		23:16	BKUP[23:16]							
		31:24	BKUP[31:24]							

# SAM D5x/E5x Family Data Sheet

## RTC – Real-Time Counter

.....continued			
Offset	Name	Bit Pos.	
0x88	BKUP2	7:0	BKUP[7:0]
		15:8	BKUP[15:8]
		23:16	BKUP[23:16]
		31:24	BKUP[31:24]
0x8C	BKUP3	7:0	BKUP[7:0]
		15:8	BKUP[15:8]
		23:16	BKUP[23:16]
		31:24	BKUP[31:24]
0x90	BKUP4	7:0	BKUP[7:0]
		15:8	BKUP[15:8]
		23:16	BKUP[23:16]
		31:24	BKUP[31:24]
0x94	BKUP5	7:0	BKUP[7:0]
		15:8	BKUP[15:8]
		23:16	BKUP[23:16]
		31:24	BKUP[31:24]
0x98	BKUP6	7:0	BKUP[7:0]
		15:8	BKUP[15:8]
		23:16	BKUP[23:16]
		31:24	BKUP[31:24]
0x9C	BKUP7	7:0	BKUP[7:0]
		15:8	BKUP[15:8]
		23:16	BKUP[23:16]
		31:24	BKUP[31:24]

### 21.10 Register Description - Mode 1 - 16-Bit Counter

This Register Description section is valid if the RTC is in COUNT16 mode (CTRLA.MODE=1).

Registers can be 8, 16, or 32 bits wide. Atomic 8-, 16-, and 32-bit accesses are supported. In addition, the 8-bit quarters and 16-bit halves of a 32-bit register, and the 8-bit halves of a 16-bit register can be accessed directly.

Some registers require synchronization when read and/or written. Synchronization is denoted by the "Read-Synchronized" and/or "Write-Synchronized" property in each individual register description.

Optional write protection by the Peripheral Access Controller (PAC) is denoted by the "PAC Write Protection" property in each individual register description.

Some registers are enable-protected, meaning they can only be written when the module is disabled. Enable protection is denoted by the "Enable-Protected" property in each individual register description.

### 21.10.1 Control A in COUNT16 mode (CTRLA.MODE=1)

**Name:** CTRLA  
**Offset:** 0x00  
**Reset:** 0x0000  
**Property:** PAC Write-Protection, Enable-Protected, Write-Synchronized

	Bit	15	14	13	12	11	10	9	8
		COUNTSYNC	GPTRST	BKTRST		PRESCALER[3:0]			
Access		R/W	R/W	R/W		R/W	R/W	R/W	R/W
Reset		0	0	0		0	0	0	0
	Bit	7	6	5	4	3	2	1	0
						MODE[1:0]		ENABLE	SWRST
Access						R/W	R/W	R/W	R/W
Reset						0	0	0	0

**Bit 15 – COUNTSYNC** COUNT Read Synchronization Enable

The COUNT register requires synchronization when reading. Disabling the synchronization will prevent reading valid values from the COUNT register.

This bit is not enable-protected.

Value	Description
0	COUNT read synchronization is disabled
1	COUNT read synchronization is enabled

**Bit 14 – GPTRST** GP Registers Reset On Tamper Enable

Only GP registers enabled by the CTRLB.GPnEN bits are affected. This bit can be written only when the peripheral is disabled.

This bit is not synchronized.

Value	Description
0	GPn registers will not reset when a tamper condition occurs.
1	GPn registers will reset when a tamper condition occurs.

**Bit 13 – BKTRST** BKUP Registers Reset On Tamper Enable

All BKUPn registers are affected. This bit can be written only when the peripheral is disabled.

This bit is not synchronized.

Value	Description
0	BKUPn registers will not reset when a tamper condition occurs.
1	BKUPn registers will reset when a tamper condition occurs.

**Bits 11:8 – PRESCALER[3:0]** Prescaler

These bits define the prescaler factor for the RTC clock source (GCLK\_RTC) to generate the counter clock (CLK\_RTC\_CNT). Periodic events and interrupts are not available when the prescaler is off. These bits are not synchronized.

Value	Name	Description
0x0	OFF	CLK_RTC_CNT = GCLK_RTC/1
0x1	DIV1	CLK_RTC_CNT = GCLK_RTC/1
0x2	DIV2	CLK_RTC_CNT = GCLK_RTC/2

# SAM D5x/E5x Family Data Sheet

## RTC – Real-Time Counter

Value	Name	Description
0x3	DIV4	CLK_RTC_CNT = GCLK_RTC/4
0x4	DIV8	CLK_RTC_CNT = GCLK_RTC/8
0x5	DIV16	CLK_RTC_CNT = GCLK_RTC/16
0x6	DIV32	CLK_RTC_CNT = GCLK_RTC/32
0x7	DIV64	CLK_RTC_CNT = GCLK_RTC/64
0x8	DIV128	CLK_RTC_CNT = GCLK_RTC/128
0x9	DIV256	CLK_RTC_CNT = GCLK_RTC/256
0xA	DIV512	CLK_RTC_CNT = GCLK_RTC/512
0xB	DIV1024	CLK_RTC_CNT = GCLK_RTC/1024
0xC–0xF	-	Reserved

### Bits 3:2 – MODE[1:0] Operating Mode

This field defines the operating mode of the RTC. This bit is not synchronized.

Value	Name	Description
0x0	COUNT32	Mode 0: 32-bit counter
0x1	COUNT16	Mode 1: 16-bit counter
0x2	CLOCK	Mode 2: Clock/calendar
0x3	-	Reserved

### Bit 1 – ENABLE Enable

Due to synchronization there is delay from writing CTRLA.ENABLE until the peripheral is enabled/disabled. The value written to CTRLA.ENABLE will read back immediately and the Enable bit in the Synchronization Busy register (SYNCBUSY.ENABLE) will be set. SYNCBUSY.ENABLE will be cleared when the operation is complete.

Value	Description
0	The peripheral is disabled
1	The peripheral is enabled

### Bit 0 – SWRST Software Reset

Writing a '0' to this bit has no effect.

Writing a '1' to this bit resets all registers in the RTC (except DBGCTRL) to their initial state, and the RTC will be disabled.

Writing a '1' to CTRLA.SWRST will always take precedence, meaning that all other writes in the same write-operation will be discarded.

Due to synchronization there is a delay from writing CTRLA.SWRST until the reset is complete.

CTRLA.SWRST will be cleared when the reset is complete.

Value	Description
0	There is not reset operation ongoing
1	The reset operation is ongoing

### 21.10.2 Control B in COUNT16 mode (CTRLA.MODE=1)

**Name:** CTRLB  
**Offset:** 0x02  
**Reset:** 0x0000  
**Property:** PAC Write-Protection, Enable-Protected

	Bit	15	14	13	12	11	10	9	8
		ACTF[2:0]					DEBF[2:0]		
Access		R/W	R/W	R/W		R/W	R/W	R/W	
Reset		0	0	0		0	0	0	
	Bit	7	6	5	4	3	2	1	0
		DMAEN	RTCOUT	DEBASYNC	DEBMAJ			GP2EN	GP0EN
Access		R/W	R/W	R/W	R/W			R/W	R/W
Reset		0	0	0	0			0	0

#### Bits 14:12 – ACTF[2:0] Active Layer Frequency

These bits define the prescaling factor for the RTC clock output (OUT) used during active layer protection in terms of the CLK\_RTC.

Value	Name	Description
0x0	DIV2	CLK_RTC_OUT = CLK_RTC / 2
0x1	DIV4	CLK_RTC_OUT = CLK_RTC / 4
0x2	DIV8	CLK_RTC_OUT = CLK_RTC / 8
0x3	DIV16	CLK_RTC_OUT = CLK_RTC / 16
0x4	DIV32	CLK_RTC_OUT = CLK_RTC / 32
0x5	DIV64	CLK_RTC_OUT = CLK_RTC / 64
0x6	DIV128	CLK_RTC_OUT = CLK_RTC / 128
0x7	DIV256	CLK_RTC_OUT = CLK_RTC / 256

#### Bits 10:8 – DEBF[2:0] Debounce Frequency

These bits define the prescaling factor for the input debouncers in terms of the CLK\_RTC.

Value	Name	Description
0x0	DIV2	CLK_RTC_DEB = CLK_RTC / 2
0x1	DIV4	CLK_RTC_DEB = CLK_RTC / 4
0x2	DIV8	CLK_RTC_DEB = CLK_RTC / 8
0x3	DIV16	CLK_RTC_DEB = CLK_RTC / 16
0x4	DIV32	CLK_RTC_DEB = CLK_RTC / 32
0x5	DIV64	CLK_RTC_DEB = CLK_RTC / 64
0x6	DIV128	CLK_RTC_DEB = CLK_RTC / 128
0x7	DIV256	CLK_RTC_DEB = CLK_RTC / 256

#### Bit 7 – DMAEN DMA Enable

The RTC can trigger a DMA request when the timestamp is ready in the TIMESTAMP register.

Value	Description
0	Tamper DMA request is disabled. Reading TIMESTAMP has no effect on INTFLAG.TAMPER.
1	Tamper DMA request is enabled. Reading TIMESTAMP will clear INTFLAG.TAMPER.



**Bit 6 – RTCOUT** RTC Output Enable

Value	Description
0	The RTC active layer output is disabled.
1	The RTC active layer output is enabled.

**Bit 5 – DEBASYNC** Debouncer Asynchronous Enable

Value	Description
0	The tamper input debouncers operate synchronously.
1	The tamper input debouncers operate asynchronously.

**Bit 4 – DEBMAJ** Debouncer Majority Enable

Value	Description
0	The tamper input debouncers match three equal values.
1	The tamper input debouncers match majority two of three values.

**Bit 1 – GP2EN** General Purpose 2 Enable

Value	Description
0	COMP1 compare function enabled. GP2/GP3 disabled.
1	COMP1 compare function disabled. GP2/GP3 enabled.

**Bit 0 – GP0EN** General Purpose 0 Enable

Value	Description
0	COMP0 compare function enabled. GP0/GP1 disabled.
1	COMP0 compare function disabled. GP0/GP1 enabled.

# SAM D5x/E5x Family Data Sheet

## RTC – Real-Time Counter

### 21.10.3 Event Control in COUNT16 mode (CTRLA.MODE=1)

**Name:** EVCTRL  
**Offset:** 0x04  
**Reset:** 0x00000000  
**Property:** PAC Write-Protection, Enable-Protected

Bit	31	30	29	28	27	26	25	24
Access								
Reset								
Bit	23	22	21	20	19	18	17	16
Access								TAMPEVEI
Reset								0
Bit	15	14	13	12	11	10	9	8
Access	R/W	R/W			R/W	R/W	R/W	R/W
Reset	0	0			0	0	0	0
Bit	7	6	5	4	3	2	1	0
Access	R/W	R/W	R/W	R/W	R/W	R/W	R/W	R/W
Reset	0	0	0	0	0	0	0	0

#### Bit 16 – TAMPEVEI Tamper Event Input Enable

Value	Description
0	Tamper event input is disabled, and incoming events will be ignored
1	Tamper event input is enabled, and incoming events will capture the COUNT value

#### Bit 15 – OVFE0 Overflow Event Output Enable

Value	Description
0	Overflow event is disabled and will not be generated.
1	Overflow event is enabled and will be generated for every overflow.

#### Bit 14 – TAMPEREO Tamper Event Output Enable

Value	Description
0	Tamper event output is disabled, and will not be generated.
1	Tamper event output is enabled, and will be generated for every tamper input.

#### Bits 8, 9, 10, 11 – CMPEOn Compare n Event Output Enable [n = 3..0]

Value	Description
0	Compare n event is disabled and will not be generated.
1	Compare n event is enabled and will be generated for every compare match.

#### Bits 0, 1, 2, 3, 4, 5, 6, 7 – PEREOn Periodic Interval n Event Output Enable [n = 7..0]

# SAM D5x/E5x Family Data Sheet

## RTC – Real-Time Counter

---

---

Value	Description
0	Periodic Interval n event is disabled and will not be generated.
1	Periodic Interval n event is enabled and will be generated.

### 21.10.4 Interrupt Enable Clear in COUNT16 mode (CTRLA.MODE=1)

**Name:** INTENCLR  
**Offset:** 0x08  
**Reset:** 0x0000  
**Property:** PAC Write-Protection

This register allows the user to disable an interrupt without doing a read-modify-write operation. Changes in this register will also be reflected in the Interrupt Enable Set (INTENSET) register.

Bit	15	14	13	12	11	10	9	8
	OVF	TAMPER			CMP3	CMP2	CMP1	CMP0
Access	R/W	R/W			R/W	R/W	R/W	R/W
Reset	0	0			0	0	0	0
Bit	7	6	5	4	3	2	1	0
	PER7	PER6	PER5	PER4	PER3	PER2	PER1	PER0
Access	R/W	R/W	R/W	R/W	R/W	R/W	R/W	R/W
Reset	0	0	0	0	0	0	0	0

#### Bit 15 – OVF Overflow Interrupt Enable

Writing a '0' to this bit has no effect. Writing a '1' to this bit will clear the Overflow Interrupt Enable bit, which disables the Overflow interrupt.

Value	Description
0	The Overflow interrupt is disabled.
1	The Overflow interrupt is enabled.

#### Bit 14 – TAMPER Tamper Interrupt Enable

Writing a '0' to this bit has no effect. Writing a '1' to this bit will clear the Tamper Interrupt Enable bit, which disables the Tamper interrupt.

Value	Description
0	The Tamper interrupt is disabled.
1	The Tamper interrupt is enabled.

#### Bits 8, 9, 10, 11 – CMPn Compare n Interrupt Enable [n = 3..0]

Writing a '0' to this bit has no effect. Writing a '1' to this bit will clear the Compare n Interrupt Enable bit, which disables the Compare n interrupt.

Value	Description
0	The Compare n interrupt is disabled.
1	The Compare n interrupt is enabled.

#### Bits 0, 1, 2, 3, 4, 5, 6, 7 – PERn Periodic Interval n Interrupt Enable [n = 7..0]

Writing a '0' to this bit has no effect. Writing a '1' to this bit will clear the Periodic Interval n Interrupt Enable bit, which disables the Periodic Interval n interrupt.

Value	Description
0	Periodic Interval n interrupt is disabled.
1	Periodic Interval n interrupt is enabled.

# SAM D5x/E5x Family Data Sheet

## RTC – Real-Time Counter

### 21.10.5 Interrupt Enable Set in COUNT16 mode (CTRLA.MODE=1)

**Name:** INTENSET  
**Offset:** 0x0A  
**Reset:** 0x0000  
**Property:** PAC Write-Protection

This register allows the user to enable an interrupt without doing a read-modify-write operation. Changes in this register will also be reflected in the Interrupt Enable Clear (INTENCLR) register.

Bit	15	14	13	12	11	10	9	8
	OVF	TAMPER			CMP3	CMP2	CMP1	CMP0
Access	R/W	R/W			R/W	R/W	R/W	R/W
Reset	0	0			0	0	0	0
Bit	7	6	5	4	3	2	1	0
	PER7	PER6	PER5	PER4	PER3	PER2	PER1	PER0
Access	R/W	R/W	R/W	R/W	R/W	R/W	R/W	R/W
Reset	0	0	0	0	0	0	0	0

#### Bit 15 – OVF Overflow Interrupt Enable

Writing a '0' to this bit has no effect. Writing a '1' to this bit will set the Overflow Interrupt Enable bit, which enables the Overflow interrupt.

Value	Description
0	The Overflow interrupt is disabled.
1	The Overflow interrupt is enabled.

#### Bit 14 – TAMPER Tamper Interrupt Enable

Writing a '0' to this bit has no effect. Writing a '1' to this bit will set the Tamper Interrupt Enable bit, which enables the Tamper interrupt.

Value	Description
0	The Tamper interrupt is disabled.
1	The Tamper interrupt is enabled.

#### Bits 8, 9, 10, 11 – CMPn Compare n Interrupt Enable [n = 3..0]

Writing a '0' to this bit has no effect. Writing a '1' to this bit will set the Compare n Interrupt Enable bit, which and enables the Compare n interrupt.

Value	Description
0	The Compare n interrupt is disabled.
1	The Compare n interrupt is enabled.

#### Bits 0, 1, 2, 3, 4, 5, 6, 7 – PERn Periodic Interval n Interrupt Enable [n = 7..0]

Writing a '0' to this bit has no effect. Writing a '1' to this bit will set the Periodic Interval n Interrupt Enable bit, which enables the Periodic Interval n interrupt.

Value	Description
0	Periodic Interval n interrupt is disabled.
1	Periodic Interval n interrupt is enabled.

### 21.10.6 Interrupt Flag Status and Clear in COUNT16 mode (CTRLA.MODE=1)

**Name:** INTFLAG  
**Offset:** 0x0C  
**Reset:** 0x0000  
**Property:** -

	15	14	13	12	11	10	9	8
	OVF	TAMPER			CMP3	CMP2	CMP1	CMP0
Access	R/W	R/W			R/W	R/W	R/W	R/W
Reset	0	0			0	0	0	0
	7	6	5	4	3	2	1	0
	PER7	PER6	PER5	PER4	PER3	PER2	PER1	PER0
Access	R/W	R/W	R/W	R/W	R/W	R/W	R/W	R/W
Reset	0	0	0	0	0	0	0	0

**Bit 15 – OVF** Overflow

This flag is cleared by writing a '1' to the flag.  
 This flag is set on the next CLK\_RTC\_CNT cycle after an overflow condition occurs, and an interrupt request will be generated if INTENCLR/SET.OVF is '1'.  
 Writing a '0' to this bit has no effect.  
 Writing a '1' to this bit clears the Overflow interrupt flag.

**Bit 14 – TAMPER** Tamper

This flag is set after a tamper condition occurs, and an interrupt request will be generated if INTENCLR.TAMPER/ INTENSET.TAMPER is one.  
 Writing a '0' to this bit has no effect.  
 Writing a one to this bit clears the Tamper interrupt flag.

**Bits 8, 9, 10, 11 – CMPn** Compare n [n = 3..0]

This flag is cleared by writing a '1' to the flag.  
 This flag is set on the next CLK\_RTC\_CNT cycle after a match with the compare condition, and an interrupt request will be generated if INTENCLR/SET.COMPn is one.  
 Writing a '0' to this bit has no effect.  
 Writing a '1' to this bit clears the Compare n interrupt flag.

**Bits 0, 1, 2, 3, 4, 5, 6, 7 – PERn** Periodic Interval n [n = 7..0]

This flag is cleared by writing a '1' to the flag.  
 This flag is set on the 0-to-1 transition of prescaler bit [n+2], and an interrupt request will be generated if INTENCLR/SET.PERx is one.  
 Writing a '0' to this bit has no effect.  
 Writing a '1' to this bit clears the Periodic Interval n interrupt flag.

### 21.10.7 Debug Control

**Name:** DBGCTRL  
**Offset:** 0x0E  
**Reset:** 0x00  
**Property:** PAC Write-Protection

	7	6	5	4	3	2	1	0
								DBGRUN
Access								R/W
Reset								0

#### Bit 0 – DBGRUN Debug Run

This bit is not reset by a software reset.

This bit controls the functionality when the CPU is halted by an external debugger.

Value	Description
0	The RTC is halted when the CPU is halted by an external debugger.
1	The RTC continues normal operation when the CPU is halted by an external debugger.

### 21.10.8 Synchronization Busy in COUNT16 mode (CTRLA.MODE=1)

**Name:** SYNCBUSY  
**Offset:** 0x10  
**Reset:** 0x00000000  
**Property:** -

Bit	31	30	29	28	27	26	25	24
Access								
Reset								
Bit	23	22	21	20	19	18	17	16
					GP3	GP2	GP1	GP0
Access					R	R	R	R
Reset					0	0	0	0
Bit	15	14	13	12	11	10	9	8
	COUNTSYNC							COMP3
Access	R							R
Reset	0							0
Bit	7	6	5	4	3	2	1	0
	COMP2	COMP1	COMP0	PER	COUNT	FREQCORR	ENABLE	SWRST
Access	R	R	R	R	R	R	R	R
Reset	0	0	0	0	0	0	0	0

#### Bits 16, 17, 18, 19 – GPn General Purpose n Synchronization Busy Status

Value	Description
0	Write synchronization for GPn register is complete.
1	Write synchronization for GPn register is ongoing.

#### Bit 15 – COUNTSYNC Count Read Sync Enable Synchronization Busy Status

Value	Description
0	Write synchronization for CTRLA.COUNTSYNC bit is complete.
1	Write synchronization for CTRLA.COUNTSYNC bit is ongoing.

#### Bits 5, 6, 7, 8 – COMPn Compare n Synchronization Busy Status [n = 3..0]

Value	Description
0	Write synchronization for COMPn register is complete.
1	Write synchronization for COMPn register is ongoing.

#### Bit 4 – PER Period Synchronization Busy Status

Value	Description
0	Write synchronization for PER register is complete.
1	Write synchronization for PER register is ongoing.

#### Bit 3 – COUNT Count Value Synchronization Busy Status



Value	Description
0	Read/write synchronization for COUNT register is complete.
1	Read/write synchronization for COUNT register is ongoing.

**Bit 2 – FREQCORR** Frequency Correction Synchronization Busy Status

Value	Description
0	Write synchronization for FREQCORR register is complete.
1	Write synchronization for FREQCORR register is ongoing.

**Bit 1 – ENABLE** Enable Synchronization Busy Status

Value	Description
0	Write synchronization for CTRLA.ENABLE bit is complete.
1	Write synchronization for CTRLA.ENABLE bit is ongoing.

**Bit 0 – SWRST** Software Reset Synchronization Busy Status

Value	Description
0	Write synchronization for CTRLA.SWRST bit is complete.
1	Write synchronization for CTRLA.SWRST bit is ongoing.

### 21.10.9 Frequency Correction

**Name:**       FREQCORR  
**Offset:**     0x14  
**Reset:**       0x00  
**Property:**   PAC Write-Protection, Write-Synchronized

	7	6	5	4	3	2	1	0
	SIGN	VALUE[6:0]						
Access	R/W	R/W	R/W	R/W	R/W	R/W	R/W	R/W
Reset	0	0	0	0	0	0	0	0

#### Bit 7 – SIGN Correction Sign

Value	Description
0	The correction value is positive, i.e., frequency will be decreased.
1	The correction value is negative, i.e., frequency will be increased.

#### Bits 6:0 – VALUE[6:0] Correction Value

These bits define the amount of correction applied to the RTC prescaler.

Value	Description
0	Correction is disabled and the RTC frequency is unchanged.
1 – 127	The RTC frequency is adjusted according to the value.

# SAM D5x/E5x Family Data Sheet

## RTC – Real-Time Counter

### 21.10.10 Counter Value in COUNT16 mode (CTRLA.MODE=1)

**Name:** COUNT  
**Offset:** 0x18  
**Reset:** 0x0000  
**Property:** PAC Write-Protection, Write-Synchronized, Read-Synchronized

Bit	15	14	13	12	11	10	9	8
	COUNT[15:8]							
Access	R/W	R/W	R/W	R/W	R/W	R/W	R/W	R/W
Reset	0	0	0	0	0	0	0	0
Bit	7	6	5	4	3	2	1	0
	COUNT[7:0]							
Access	R/W	R/W	R/W	R/W	R/W	R/W	R/W	R/W
Reset	0	0	0	0	0	0	0	0

#### Bits 15:0 – COUNT[15:0] Counter Value

These bits define the value of the 16-bit RTC counter in COUNT16 mode (CTRLA.MODE=1).

### 21.10.11 Counter Period in COUNT16 mode (CTRLA.MODE=1)

**Name:** PER  
**Offset:** 0x1C  
**Reset:** 0x0000  
**Property:** PAC Write-Protection, Write-Synchronized

	Bit	15	14	13	12	11	10	9	8
	PER[15:8]								
Access	R/W	R/W	R/W	R/W	R/W	R/W	R/W	R/W	R/W
Reset	0	0	0	0	0	0	0	0	0
	Bit	7	6	5	4	3	2	1	0
	PER[7:0]								
Access	R/W	R/W	R/W	R/W	R/W	R/W	R/W	R/W	R/W
Reset	0	0	0	0	0	0	0	0	0

**Bits 15:0 – PER[15:0] Counter Period**

These bits define the value of the 16-bit RTC period in COUNT16 mode (CTRLA.MODE=1).

### 21.10.12 Compare n Value in COUNT16 mode (CTRLA.MODE=1)

**Name:** COMP  
**Offset:** 0x20 + n\*0x02 [n=0..3]  
**Reset:** 0x0000  
**Property:** PAC Write-Protection, Write-Synchronized

	Bit	15	14	13	12	11	10	9	8
	COMP[15:8]								
Access	R/W	R/W	R/W	R/W	R/W	R/W	R/W	R/W	R/W
Reset	0	0	0	0	0	0	0	0	0
	Bit	7	6	5	4	3	2	1	0
	COMP[7:0]								
Access	R/W	R/W	R/W	R/W	R/W	R/W	R/W	R/W	R/W
Reset	0	0	0	0	0	0	0	0	0

**Bits 15:0 – COMP[15:0] Compare Value**

The 16-bit value of COMPn is continuously compared with the 16-bit COUNT value. When a match occurs, the Compare n interrupt flag in the Interrupt Flag Status and Clear register (INTFLAG.CMPn) is set on the next counter cycle.

# SAM D5x/E5x Family Data Sheet

## RTC – Real-Time Counter

### 21.10.13 General Purpose n

**Name:** GPn  
**Offset:** 0x40 + n\*0x04 [n=0..3]  
**Reset:** 0x00000000  
**Property:** -

Bit	31	30	29	28	27	26	25	24
	GP[31:24]							
Access	R/W	R/W	R/W	R/W	R/W	R/W	R/W	R/W
Reset	0	0	0	0	0	0	0	0
Bit	23	22	21	20	19	18	17	16
	GP[23:16]							
Access	R/W	R/W	R/W	R/W	R/W	R/W	R/W	R/W
Reset	0	0	0	0	0	0	0	0
Bit	15	14	13	12	11	10	9	8
	GP[15:8]							
Access	R/W	R/W	R/W	R/W	R/W	R/W	R/W	R/W
Reset	0	0	0	0	0	0	0	0
Bit	7	6	5	4	3	2	1	0
	GP[7:0]							
Access	R/W	R/W	R/W	R/W	R/W	R/W	R/W	R/W
Reset	0	0	0	0	0	0	0	0

#### Bits 31:0 – GP[31:0] General Purpose

These bits are for user-defined general purpose use, see [21.6.8.4 General Purpose Registers](#).

# SAM D5x/E5x Family Data Sheet

## RTC – Real-Time Counter

### 21.10.14 Tamper Control

**Name:** TAMPCTRL  
**Offset:** 0x60  
**Reset:** 0x00000000  
**Property:** PAC Write-Protection, Enable-Protected

	Bit	31	30	29	28	27	26	25	24
					DEBNC4	DEBNC3	DEBNC2	DEBNC1	DEBNC0
Access									
Reset					0	0	0	0	0
	Bit	23	22	21	20	19	18	17	16
					TAMLVL4	TAMLVL3	TAMLVL2	TAMLVL1	TAMLVL0
Access									
Reset					0	0	0	0	0
	Bit	15	14	13	12	11	10	9	8
								IN4ACT[1:0]	
Access									
Reset								0	0
	Bit	7	6	5	4	3	2	1	0
		IN3ACT[1:0]		IN2ACT[1:0]		IN1ACT[1:0]		IN0ACT[1:0]	
Access									
Reset		0	0	0	0	0	0	0	0

**Bits 24, 25, 26, 27, 28 – DEBNC** Debounce Enable of Tamper Input INn

**Note:** Debounce feature does not apply to the Active Layer Protection mode (TAMPCTRL.INACT = ACTL).

Value	Description
0	Debouncing is disabled for Tamper input INn
1	Debouncing is enabled for Tamper input INn

**Bits 16, 17, 18, 19, 20 – TAMLVL** Tamper Level Select of Tamper Input INn

**Note:** Tamper Level feature does not apply to the Active Layer Protection mode (TAMPCTRL.INACT = ACTL).

Value	Description
0	A falling edge condition will be detected on Tamper input INn.
1	A rising edge condition will be detected on Tamper input INn.

**Bits 0:1, 2:3, 4:5, 6:7, 8:9 – INACT** Tamper Channel n Action

These bits determine the action taken by Tamper Channel n.

Value	Name	Description
0x0	OFF	Off (Disabled)
0x1	WAKE	Wake and set Tamper flag
0x2	CAPTURE	Capture timestamp and set Tamper flag

# SAM D5x/E5x Family Data Sheet

## RTC – Real-Time Counter

---

---

Value	Name	Description
0x3	ACTL	Compare RTC signal routed between INn and OUT pins . When a mismatch occurs, capture timestamp and set Tamper flag



# SAM D5x/E5x Family Data Sheet

## RTC – Real-Time Counter

### 21.10.15 Timestamp

**Name:**       TIMESTAMP  
**Offset:**     0x64  
**Reset:**      0x0000  
**Property:**   Read-Only

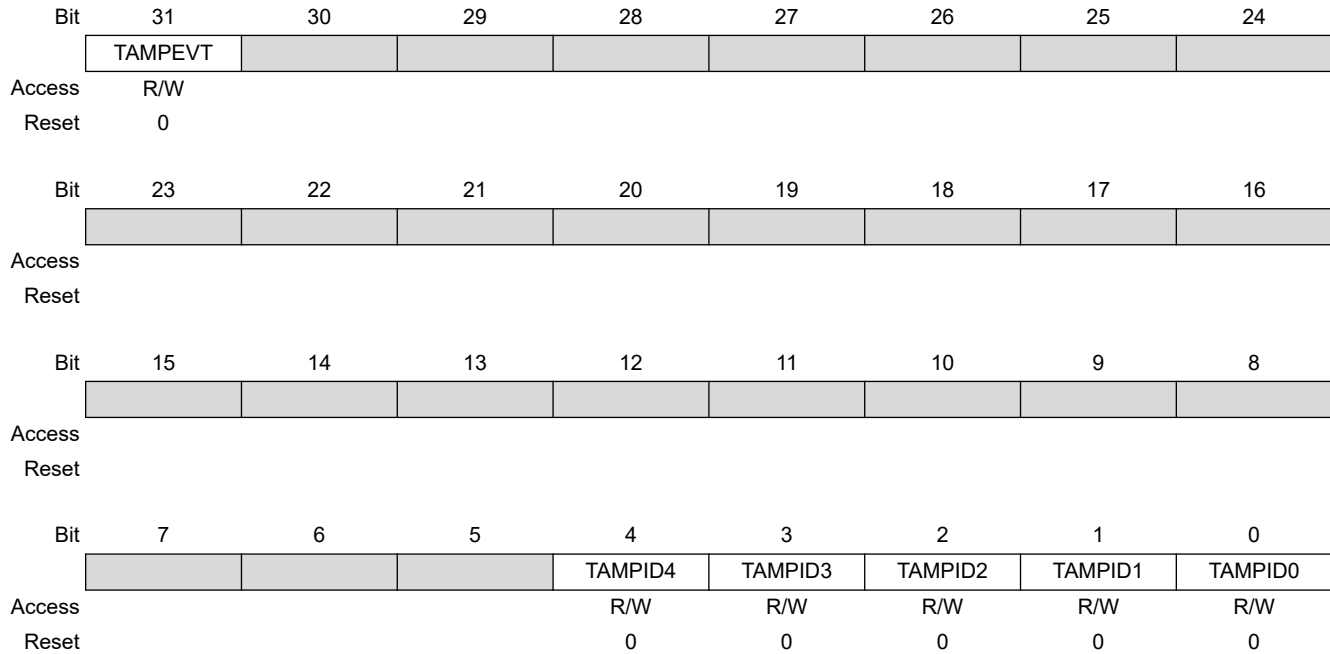
Bit	31	30	29	28	27	26	25	24
	[Greyed out register bits]							
Access								
Reset								
Bit	23	22	21	20	19	18	17	16
	[Greyed out register bits]							
Access								
Reset								
Bit	15	14	13	12	11	10	9	8
	COUNT[15:8]							
Access	R	R	R	R	R	R	R	R
Reset	0	0	0	0	0	0	0	0
Bit	7	6	5	4	3	2	1	0
	COUNT[7:0]							
Access	R	R	R	R	R	R	R	R
Reset	0	0	0	0	0	0	0	0

**Bits 15:0 – COUNT[15:0]** Count Timestamp Value

The 16-bit value of COUNT is captured by the TIMESTAMP when a tamper condition occurs.

### 21.10.16 Tamper ID

**Name:** TAMPID  
**Offset:** 0x68  
**Reset:** 0x00000000



**Bit 31 – TAMPEVT** Tamper Event Detected

Writing a '0' to this bit has no effect. Writing a '1' to this bit clears the tamper detection bit.

Value	Description
0	A tamper input event has not been detected
1	A tamper input event has been detected

**Bits 0, 1, 2, 3, 4 – TAMPID** Tamper on Channel n Detected

Writing a '0' to this bit has no effect. Writing a '1' to this bit clears the tamper detection bit.

Value	Description
0	A tamper condition has not been detected on Channel n
1	A tamper condition has been detected on Channel n

# SAM D5x/E5x Family Data Sheet

## RTC – Real-Time Counter

### 21.10.17 Backup n

**Name:** BKUP  
**Offset:** 0x80 + n\*0x04 [n=0..7]  
**Reset:** 0x00000000  
**Property:** PAC Write-Protection

Bit	31	30	29	28	27	26	25	24
BKUP[31:24]								
Access	R/W	R/W	R/W	R/W	R/W	R/W	R/W	R/W
Reset	0	0	0	0	0	0	0	0
Bit	23	22	21	20	19	18	17	16
BKUP[23:16]								
Access	R/W	R/W	R/W	R/W	R/W	R/W	R/W	R/W
Reset	0	0	0	0	0	0	0	0
Bit	15	14	13	12	11	10	9	8
BKUP[15:8]								
Access	R/W	R/W	R/W	R/W	R/W	R/W	R/W	R/W
Reset	0	0	0	0	0	0	0	0
Bit	7	6	5	4	3	2	1	0
BKUP[7:0]								
Access	R/W	R/W	R/W	R/W	R/W	R/W	R/W	R/W
Reset	0	0	0	0	0	0	0	0

#### Bits 31:0 – BKUP[31:0] Backup

These bits are user-defined for general purpose use in the Backup domain.

# SAM D5x/E5x Family Data Sheet

## RTC – Real-Time Counter

### 21.11 Register Summary - Mode 2 - Clock/Calendar

Offset	Name	Bit Pos.								
0x00	CTRLA	7:0	MATCHCLR	CLKREP			MODE[1:0]		ENABLE	SWRST
		15:8	CLOCKSYNC	GPTRST	BKTRST		PRESCALER[3:0]			
0x02	CTRLB	7:0	DMAEN	RTCOUT	DEBASync	DEBMAJ			GP2EN	GP0EN
		15:8		ACTF[2:0]				DEBF[2:0]		
0x04	EVCTRL	7:0	PERE07	PERE06	PERE05	PERE04	PERE03	PERE02	PERE01	PERE00
		15:8	OVFEO	TAMPERO					ALARMEO1	ALARMEO0
		23:16								TAMPEVEI
		31:24								
0x08	INTENCLR	7:0	PER7	PER6	PER5	PER4	PER3	PER2	PER1	PER0
		15:8	OVF	TAMPER					ALARM1	ALARM0
0x0A	INTENSET	7:0	PER7	PER6	PER5	PER4	PER3	PER2	PER1	PER0
		15:8	OVF	TAMPER					ALARM1	ALARM0
0x0C	INTFLAG	7:0	PER7	PER6	PER5	PER4	PER3	PER2	PER1	PER0
		15:8	OVF	TAMPER					ALARM1	ALARM0
0x0E	DBGCTRL	7:0								DBGRUN
0x0F	Reserved									
0x10	SYNCBUSY	7:0		ALARM1	ALARM0		CLOCK	FREQCORR	ENABLE	SWRST
		15:8	CLOCKSYNC			MASK1	MASK0			
		23:16					GP3	GP2	GP1	GP0
		31:24								
0x14	FREQCORR	7:0	SIGN	VALUE[6:0]						
0x15 ... 0x17	Reserved									
0x18	CLOCK	7:0	MINUTE[1:0]			SECOND[5:0]				
		15:8	HOUR[3:0]				MINUTE[5:2]			
		23:16	MONTH[1:0]			DAY[4:0]				HOUR[4:4]
		31:24	YEAR[5:0]						MONTH[3:2]	
0x1C ... 0x1F	Reserved									
0x20	ALARM0	7:0	MINUTE[1:0]			SECOND[5:0]				
		15:8	HOUR[3:0]				MINUTE[5:2]			
		23:16	MONTH[1:0]			DAY[4:0]				HOUR[4:4]
		31:24	YEAR[5:0]						MONTH[3:2]	
0x24	MASK0	7:0						SEL[2:0]		
0x25 ... 0x27	Reserved									
0x28	ALARM1	7:0	MINUTE[1:0]			SECOND[5:0]				
		15:8	HOUR[3:0]				MINUTE[5:2]			
		23:16	MONTH[1:0]			DAY[4:0]				HOUR[4:4]
		31:24	YEAR[5:0]						MONTH[3:2]	

# SAM D5x/E5x Family Data Sheet

## RTC – Real-Time Counter

.....continued									
Offset	Name	Bit Pos.							
0x2C	<b>MASK1</b>	7:0							SEL[2:0]
0x2D ... 0x3F	Reserved								
0x40	<b>GP0</b>	7:0	GP[7:0]						
		15:8	GP[15:8]						
		23:16	GP[23:16]						
		31:24	GP[31:24]						
0x44	<b>GP1</b>	7:0	GP[7:0]						
		15:8	GP[15:8]						
		23:16	GP[23:16]						
		31:24	GP[31:24]						
0x48	<b>GP2</b>	7:0	GP[7:0]						
		15:8	GP[15:8]						
		23:16	GP[23:16]						
		31:24	GP[31:24]						
0x4C	<b>GP3</b>	7:0	GP[7:0]						
		15:8	GP[15:8]						
		23:16	GP[23:16]						
		31:24	GP[31:24]						
0x50 ... 0x5F	Reserved								
0x60	<b>TAMPCTRL</b>	7:0	IN3ACT[1:0]	IN2ACT[1:0]	IN1ACT[1:0]	IN0ACT[1:0]			
		15:8	IN4ACT[1:0]						
		23:16		TAMLVL4	TAMLVL3	TAMLVL2	TAMLVL1	TAMLVL0	
		31:24		DEBNC4	DEBNC3	DEBNC2	DEBNC1	DEBNC0	
0x64	<b>TIMESTAMP</b>	7:0	MINUTE[1:0]	SECOND[5:0]					
		15:8	HOUR[3:0]			MINUTE[5:2]			
		23:16	MONTH[1:0]	DAY[4:0]				HOUR[4:4]	
		31:24	YEAR[5:0]					MONTH[3:2]	
0x68	<b>TAMPID</b>	7:0		TAMPID4	TAMPID3	TAMPID2	TAMPID1	TAMPID0	
		15:8							
		23:16							
		31:24	TAMPEVT						
0x6C ... 0x7F	Reserved								
0x80	<b>BKUP0</b>	7:0	BKUP[7:0]						
		15:8	BKUP[15:8]						
		23:16	BKUP[23:16]						
		31:24	BKUP[31:24]						

# SAM D5x/E5x Family Data Sheet

## RTC – Real-Time Counter

.....continued			
Offset	Name	Bit Pos.	
0x84	BKUP1	7:0	BKUP[7:0]
		15:8	BKUP[15:8]
		23:16	BKUP[23:16]
		31:24	BKUP[31:24]
0x88	BKUP2	7:0	BKUP[7:0]
		15:8	BKUP[15:8]
		23:16	BKUP[23:16]
		31:24	BKUP[31:24]
0x8C	BKUP3	7:0	BKUP[7:0]
		15:8	BKUP[15:8]
		23:16	BKUP[23:16]
		31:24	BKUP[31:24]
0x90	BKUP4	7:0	BKUP[7:0]
		15:8	BKUP[15:8]
		23:16	BKUP[23:16]
		31:24	BKUP[31:24]
0x94	BKUP5	7:0	BKUP[7:0]
		15:8	BKUP[15:8]
		23:16	BKUP[23:16]
		31:24	BKUP[31:24]
0x98	BKUP6	7:0	BKUP[7:0]
		15:8	BKUP[15:8]
		23:16	BKUP[23:16]
		31:24	BKUP[31:24]
0x9C	BKUP7	7:0	BKUP[7:0]
		15:8	BKUP[15:8]
		23:16	BKUP[23:16]
		31:24	BKUP[31:24]

### 21.12 Register Description - Mode 2 - Clock/Calendar

This Register Description section is valid if the RTC is in Clock/Calendar mode (CTRLA.MODE=2).

Registers can be 8, 16, or 32 bits wide. Atomic 8-, 16-, and 32-bit accesses are supported. In addition, the 8-bit quarters and 16-bit halves of a 32-bit register, and the 8-bit halves of a 16-bit register can be accessed directly.

Some registers require synchronization when read and/or written. Synchronization is denoted by the "Read-Synchronized" and/or "Write-Synchronized" property in each individual register description.

Optional write protection by the Peripheral Access Controller (PAC) is denoted by the "PAC Write Protection" property in each individual register description.

Some registers are enable-protected, meaning they can only be written when the module is disabled. Enable protection is denoted by the "Enable-Protected" property in each individual register description.

### 21.12.1 Control A in Clock/Calendar mode (CTRLA.MODE=2)

**Name:** CTRLA  
**Offset:** 0x00  
**Reset:** 0x0000  
**Property:** PAC Write-Protection, Enable-Protected, Write-Synchronized

Bit	15	14	13	12	11	10	9	8
	CLOCKSYNC	GPTRST	BKTRST		PRESCALER[3:0]			
Access	R/W	R/W	R/W		R/W	R/W	R/W	R/W
Reset	0	0	0		0	0	0	0
Bit	7	6	5	4	3	2	1	0
	MATCHCLR	CLKREP			MODE[1:0]		ENABLE	SWRST
Access	R/W	R/W			R/W	R/W	R/W	R/W
Reset	0	0			0	0	0	0

#### Bit 15 – CLOCKSYNC CLOCK Read Synchronization Enable

The CLOCK register requires synchronization when reading. Disabling the synchronization will prevent reading valid values from the CLOCK register.

This bit is not enable-protected.

Value	Description
0	CLOCK read synchronization is disabled
1	CLOCK read synchronization is enabled

#### Bit 14 – GPTRST GP Registers Reset On Tamper Enable

Only GP registers enabled by the CTRLB.GPnEN bits are affected. This bit can be written only when the peripheral is disabled.

This bit is not synchronized.

#### Bit 13 – BKTRST BKUP Registers Reset On Tamper Enable

All BKUPn registers are affected. This bit can be written only when the peripheral is disabled.

This bit is not synchronized.

Value	Description
0	BKUPn registers will not reset when a tamper condition occurs.
1	BKUPn registers will reset when a tamper condition occurs.

#### Bits 11:8 – PRESCALER[3:0] Prescaler

These bits define the prescaling factor for the RTC clock source (GCLK\_RTC) to generate the counter clock (CLK\_RTC\_CNT). Periodic events and interrupts are not available when the prescaler is off. These bits are not synchronized.

Value	Name	Description
0x0	OFF	CLK_RTC_CNT = GCLK_RTC/1
0x1	DIV1	CLK_RTC_CNT = GCLK_RTC/1
0x2	DIV2	CLK_RTC_CNT = GCLK_RTC/2
0x3	DIV4	CLK_RTC_CNT = GCLK_RTC/4
0x4	DIV8	CLK_RTC_CNT = GCLK_RTC/8
0x5	DIV16	CLK_RTC_CNT = GCLK_RTC/16

# SAM D5x/E5x Family Data Sheet

## RTC – Real-Time Counter

Value	Name	Description
0x6	DIV32	CLK_RTC_CNT = GCLK_RTC/32
0x7	DIV64	CLK_RTC_CNT = GCLK_RTC/64
0x8	DIV128	CLK_RTC_CNT = GCLK_RTC/128
0x9	DIV256	CLK_RTC_CNT = GCLK_RTC/256
0xA	DIV512	CLK_RTC_CNT = GCLK_RTC/512
0xB	DIV1024	CLK_RTC_CNT = GCLK_RTC/1024
0xC-0xF	-	Reserved

### Bit 7 – MATCHCLR Clear on Match

This bit is valid only in Mode 0 (COUNT32) and Mode 2 (CLOCK). This bit can be written only when the peripheral is disabled. This bit is not synchronized.

Value	Description
0	The counter is not cleared on a Compare/Alarm 0 match
1	The counter is cleared on a Compare/Alarm 0 match

### Bit 6 – CLKREP Clock Representation

This bit is valid only in Mode 2 and determines how the hours are represented in the Clock Value (CLOCK) register. This bit can be written only when the peripheral is disabled. This bit is not synchronized.

Value	Description
0	24 Hour
1	12 Hour (AM/PM)

### Bits 3:2 – MODE[1:0] Operating Mode

This field defines the operating mode of the RTC. This bit is not synchronized.

Value	Name	Description
0x0	COUNT32	Mode 0: 32-bit counter
0x1	COUNT16	Mode 1: 16-bit counter
0x2	CLOCK	Mode 2: Clock/calendar
0x3	-	Reserved

### Bit 1 – ENABLE Enable

Due to synchronization there is delay from writing CTRLA.ENABLE until the peripheral is enabled/disabled. The value written to CTRLA.ENABLE will read back immediately and the Enable bit in the Synchronization Busy register (SYNCBUSY.ENABLE) will be set. SYNCBUSY.ENABLE will be cleared when the operation is complete.

Value	Description
0	The peripheral is disabled
1	The peripheral is enabled

### Bit 0 – SWRST Software Reset

Writing a '0' to this bit has no effect.

Writing a '1' to this bit resets all registers in the RTC, except DBGCTRL, to their initial state, and the RTC will be disabled.

Writing a '1' to CTRLA.SWRST will always take precedence, meaning that all other writes in the same write-operation will be discarded.

Due to synchronization there is a delay from writing CTRLA.SWRST until the reset is complete.

CTRLA.SWRST will be cleared when the reset is complete.



# SAM D5x/E5x Family Data Sheet

## RTC – Real-Time Counter

---

---

Value	Description
0	There is not reset operation ongoing
1	The reset operation is ongoing

### 21.12.2 Control B in Clock/Calendar mode (CTRLA.MODE=2)

**Name:** CTRLB  
**Offset:** 0x2  
**Reset:** 0x0000  
**Property:** PAC Write-Protection, Enable-Protected

	Bit	15	14	13	12	11	10	9	8
		ACTF[2:0]					DEBF[2:0]		
Access		R/W	R/W	R/W		R/W	R/W	R/W	
Reset		0	0	0		0	0	0	
	Bit	7	6	5	4	3	2	1	0
		DMAEN	RTCOUT	DEBASYNC	DEBMAJ			GP2EN	GP0EN
Access		R/W	R/W	R/W	R/W			R/W	R/W
Reset		0	0	0	0			0	0

#### Bits 14:12 – ACTF[2:0] Active Layer Frequency

These bits define the prescaling factor for the RTC clock output (OUT) used during active layer protection in terms of the CLK\_RTC.

Value	Name	Description
0x0	DIV2	CLK_RTC_OUT = CLK_RTC / 2
0x1	DIV4	CLK_RTC_OUT = CLK_RTC / 4
0x2	DIV8	CLK_RTC_OUT = CLK_RTC / 8
0x3	DIV16	CLK_RTC_OUT = CLK_RTC / 16
0x4	DIV32	CLK_RTC_OUT = CLK_RTC / 32
0x5	DIV64	CLK_RTC_OUT = CLK_RTC / 64
0x6	DIV128	CLK_RTC_OUT = CLK_RTC / 128
0x7	DIV256	CLK_RTC_OUT = CLK_RTC / 256

#### Bits 10:8 – DEBF[2:0] Debounce Frequency

These bits define the prescaling factor for the input debouncers in terms of the CLK\_RTC.

Value	Name	Description
0x0	DIV2	CLK_RTC_DEB = CLK_RTC / 2
0x1	DIV4	CLK_RTC_DEB = CLK_RTC / 4
0x2	DIV8	CLK_RTC_DEB = CLK_RTC / 8
0x3	DIV16	CLK_RTC_DEB = CLK_RTC / 16
0x4	DIV32	CLK_RTC_DEB = CLK_RTC / 32
0x5	DIV64	CLK_RTC_DEB = CLK_RTC / 64
0x6	DIV128	CLK_RTC_DEB = CLK_RTC / 128
0x7	DIV256	CLK_RTC_DEB = CLK_RTC / 256

#### Bit 7 – DMAEN DMA Enable

The RTC can trigger a DMA request when the timestamp is ready in the TIMESTAMP register.

Value	Description
0	Tamper DMA request is disabled. Reading TIMESTAMP has no effect on INTFLAG.TAMPER.
1	Tamper DMA request is enabled. Reading TIMESTAMP will clear INTFLAG.TAMPER.

**Bit 6 – RTCOUT** RTC Out Enable

Value	Description
0	The RTC active layer output is disabled.
1	The RTC active layer output is enabled.

**Bit 5 – DEBASYNC** Debouncer Asynchronous Enable

Value	Description
0	The tamper input debouncers operate synchronously.
1	The tamper input debouncers operate asynchronously.

**Bit 4 – DEBMAJ** Debouncer Majority Enable

Value	Description
0	The tamper input debouncers match three equal values.
1	The tamper input debouncers match majority two of three values.

**Bit 1 – GP2EN** General Purpose 2 Enable

Value	Description
0	COMP1 compare function enabled. GP2/GP3 disabled.
1	COMP1 compare function disabled. GP2/GP3 enabled.

**Bit 0 – GP0EN** General Purpose 0 Enable

Value	Description
0	COMP0 compare function enabled. GP0 disabled.
1	COMP0 compare function disabled. GP0 enabled.

### 21.12.3 Event Control in Clock/Calendar mode (CTRLA.MODE=2)

**Name:** EVCTRL  
**Offset:** 0x04  
**Reset:** 0x00000000  
**Property:** PAC Write-Protection, Enable-Protected

	31	30	29	28	27	26	25	24	
Access									
Reset									
	23	22	21	20	19	18	17	16	
Access								TAMPEVEI	
Reset								0	
	15	14	13	12	11	10	9	8	
Access	OVFEO	TAMPEREO						ALARMEO1	ALARMEO0
Reset	0	0						0	0
	7	6	5	4	3	2	1	0	
Access	PEREO7	PEREO6	PEREO5	PEREO4	PEREO3	PEREO2	PEREO1	PEREO0	
Reset	0	0	0	0	0	0	0	0	

#### Bit 16 – TAMPEVEI Tamper Event Input Enable

Value	Description
0	Tamper event input is disabled, and incoming events will be ignored.
1	Tamper event input is enabled, and all incoming events will capture the CLOCK value.

#### Bit 15 – OVFEO Overflow Event Output Enable

Value	Description
0	Overflow event is disabled and will not be generated.
1	Overflow event is enabled and will be generated for every overflow.

#### Bit 14 – TAMPEREO Tamper Event Output Enable

Value	Description
0	Tamper event output is disabled, and will not be generated
1	Tamper event output is enabled, and will be generated for every tamper input.

#### Bits 8, 9 – ALARMEOn Alarm n Event Output Enable [n = 1..0]

Value	Description
0	Alarm n event is disabled and will not be generated.
1	Alarm n event is enabled and will be generated for every compare match.

#### Bits 0, 1, 2, 3, 4, 5, 6, 7 – PEREOn Periodic Interval n Event Output Enable [n = 7..0]

# SAM D5x/E5x Family Data Sheet

## RTC – Real-Time Counter

---

---

Value	Description
0	Periodic Interval n event is disabled and will not be generated.
1	Periodic Interval n event is enabled and will be generated.

### 21.12.4 Interrupt Enable Clear in Clock/Calendar mode (CTRLA.MODE=2)

**Name:** INTENCLR  
**Offset:** 0x08  
**Reset:** 0x0000  
**Property:** PAC Write-Protection

This register allows the user to disable an interrupt without doing a read-modify-write operation. Changes in this register will also be reflected in the Interrupt Enable Set (INTENSET) register.

Bit	15	14	13	12	11	10	9	8
	OVF	TAMPER					ALARM1	ALARM0
Access	R/W	R/W					R/W	R/W
Reset	0	0					0	0
Bit	7	6	5	4	3	2	1	0
	PER7	PER6	PER5	PER4	PER3	PER2	PER1	PER0
Access	R/W	R/W	R/W	R/W	R/W	R/W	R/W	R/W
Reset	0	0	0	0	0	0	0	0

#### Bit 15 – OVF Overflow Interrupt Enable

Writing a '0' to this bit has no effect. Writing a '1' to this bit will clear the Overflow Interrupt Enable bit, which disables the Overflow interrupt.

Value	Description
0	The Overflow interrupt is disabled.
1	The Overflow interrupt is enabled.

#### Bit 14 – TAMPER Tamper Interrupt Enable

#### Bits 8, 9 – ALARMin Alarm n Interrupt Enable [n = 1..0]

Writing a '0' to this bit has no effect. Writing a '1' to this bit will clear the Alarm n Interrupt Enable bit, which disables the Alarm n interrupt.

Value	Description
0	The Alarm n interrupt is disabled.
1	The Alarm n interrupt is enabled.

#### Bits 0, 1, 2, 3, 4, 5, 6, 7 – PERn Periodic Interval n Interrupt Enable [n = 7..0]

Writing a '0' to this bit has no effect. Writing a '1' to this bit will clear the Periodic Interval n Interrupt Enable bit, which disables the Periodic Interval n interrupt.

Value	Description
0	Periodic Interval n interrupt is disabled.
1	Periodic Interval n interrupt is enabled.

### 21.12.5 Interrupt Enable Set in Clock/Calendar mode (CTRLA.MODE=2)

**Name:** INTENSET  
**Offset:** 0x0A  
**Reset:** 0x0000  
**Property:** PAC Write-Protection

This register allows the user to enable an interrupt without doing a read-modify-write operation. Changes in this register will also be reflected in the Interrupt Enable Clear (INTENCLR) register.

Bit	15	14	13	12	11	10	9	8
	OVF	TAMPER					ALARM1	ALARM0
Access	R/W	R/W					R/W	R/W
Reset	0	0					0	0
Bit	7	6	5	4	3	2	1	0
	PER7	PER6	PER5	PER4	PER3	PER2	PER1	PER0
Access	R/W	R/W	R/W	R/W	R/W	R/W	R/W	R/W
Reset	0	0	0	0	0	0	0	0

#### Bit 15 – OVF Overflow Interrupt Enable

Writing a '0' to this bit has no effect. Writing a '1' to this bit will set the Overflow Interrupt Enable bit, which enables the Overflow interrupt.

Value	Description
0	The Overflow interrupt is disabled.
1	The Overflow interrupt is enabled.

#### Bit 14 – TAMPER Tamper Interrupt Enable

Writing a '0' to this bit has no effect. Writing a '1' to this bit will set the Tamper Interrupt Enable bit, which enables the Tamper interrupt.

Value	Description
0	The Tamper interrupt it disabled.
1	The Tamper interrupt is enabled.

#### Bits 8, 9 – ALARMn Alarm n Interrupt Enable [n = 1..0]

Writing a '0' to this bit has no effect. Writing a '1' to this bit will set the Alarm n Interrupt Enable bit, which and enables the Alarm n interrupt.

Value	Description
0	The Alarm n interrupt is disabled.
1	The Alarm n interrupt is enabled.

#### Bits 0, 1, 2, 3, 4, 5, 6, 7 – PERn Periodic Interval n Interrupt Enable [n = 7..0]

Writing a '0' to this bit has no effect. Writing a '1' to this bit will set the Periodic Interval n Interrupt Enable bit, which enables the Periodic Interval n interrupt.

Value	Description
0	Periodic Interval n interrupt is disabled.
1	Periodic Interval n interrupt is enabled.

### 21.12.6 Interrupt Flag Status and Clear in Clock/Calendar mode (CTRLA.MODE=2)

**Name:** INTFLAG  
**Offset:** 0x0C  
**Reset:** 0x0000  
**Property:** -

	15	14	13	12	11	10	9	8
	OVF	TAMPER					ALARM1	ALARM0
Access	R/W	R/W					R/W	R/W
Reset	0	0					0	0
	7	6	5	4	3	2	1	0
	PER7	PER6	PER5	PER4	PER3	PER2	PER1	PER0
Access	R/W	R/W	R/W	R/W	R/W	R/W	R/W	R/W
Reset	0	0	0	0	0	0	0	0

**Bit 15 – OVF** Overflow

This flag is cleared by writing a '1' to the flag.  
 This flag is set on the next CLK\_RTC\_CNT cycle after an overflow condition occurs, and an interrupt request will be generated if INTENCLR/SET.OVF is '1'.  
 Writing a '0' to this bit has no effect.  
 Writing a '1' to this bit clears the Overflow interrupt flag.

**Bit 14 – TAMPER** Tamper

This flag is set after a tamper condition occurs, and an interrupt request will be generated if INTENCLR.TAMPER/INTENSET.TAMPER is '1'. Writing a '0' to this bit has no effect. Writing a '1' to this bit clears the Tamper interrupt flag.

**Bits 8, 9 – ALARMn** Alarm n [n = 1..0]

This flag is cleared by writing a '1' to the flag.  
 This flag is set on the next CLK\_RTC\_CNT cycle after a match with the compare condition, and an interrupt request will be generated if INTENCLR/SET.ALARMn is one.  
 Writing a '0' to this bit has no effect.  
 Writing a '1' to this bit clears the Alarm n interrupt flag.

**Bits 0, 1, 2, 3, 4, 5, 6, 7 – PERn** Periodic Interval n [n = 7..0]

This flag is cleared by writing a '1' to the flag.  
 This flag is set on the 0-to-1 transition of prescaler bit [n+2], and an interrupt request will be generated if INTENCLR/SET.PERx is '1'.  
 Writing a '0' to this bit has no effect.  
 Writing a '1' to this bit clears the Periodic Interval n interrupt flag.



### 21.12.7 Debug Control

**Name:** DBGCTRL  
**Offset:** 0x0E  
**Reset:** 0x00  
**Property:** PAC Write-Protection

Bit	7	6	5	4	3	2	1	0
								DBGRUN
Access								R/W
Reset								0

**Bit 0 – DBGRUN** Debug Run

This bit is not reset by a software reset.

This bit controls the functionality when the CPU is halted by an external debugger.

Value	Description
0	The RTC is halted when the CPU is halted by an external debugger.
1	The RTC continues normal operation when the CPU is halted by an external debugger.

### 21.12.8 Synchronization Busy in Clock/Calendar mode (CTRLA.MODE=2)

**Name:** SYNCBUSY  
**Offset:** 0x10  
**Reset:** 0x00000000  
**Property:** -

Bit	31	30	29	28	27	26	25	24
Access								
Reset								
Bit	23	22	21	20	19	18	17	16
					GP3	GP2	GP1	GP0
Access					R	R	R	R
Reset					0	0	0	0
Bit	15	14	13	12	11	10	9	8
	CLOCKSYNC			MASK1	MASK0			
Access	R			R	R			
Reset	0			0	0			
Bit	7	6	5	4	3	2	1	0
		ALARM1	ALARM0		CLOCK	FREQCORR	ENABLE	SWRST
Access		R	R		R	R	R	R
Reset		0	0		0	0	0	0

#### Bits 16, 17, 18, 19 – Gp<sub>n</sub> General Purpose n Synchronization Busy Status

Value	Description
0	Write synchronization for GP <sub>n</sub> register is complete.
1	Write synchronization for GP <sub>n</sub> register is ongoing.

#### Bit 15 – CLOCKS<sub>SYNC</sub> Clock Read Sync Enable Synchronization Busy Status

Value	Description
0	Write synchronization for CTRLA.CLOCKS <sub>SYNC</sub> bit is complete.
1	Write synchronization for CTRLA.CLOCKS <sub>SYNC</sub> bit is ongoing.

#### Bits 11, 12 – MASK<sub>n</sub> Mask n Synchronization Busy Status [n = 1..0]

Value	Description
0	Write synchronization for MASK <sub>x</sub> register is complete.
1	Write synchronization for MASK <sub>x</sub> register is ongoing.

#### Bits 5, 6 – ALARM<sub>n</sub> Alarm n Synchronization Busy Status [n = 1..0]

Value	Description
0	Write synchronization for ALARM <sub>x</sub> register is complete.
1	Write synchronization for ALARM <sub>x</sub> register is ongoing.

#### Bit 3 – CLO<sub>CK</sub> Clock Register Synchronization Busy Status

Value	Description
0	Read/write synchronization for CLOCK register is complete.
1	Read/write synchronization for CLOCK register is ongoing.

**Bit 2 – FREQCORR** Frequency Correction Synchronization Busy Status

Value	Description
0	Write synchronization for FREQCORR register is complete.
1	Write synchronization for FREQCORR register is ongoing.

**Bit 1 – ENABLE** Enable Synchronization Busy Status

Value	Description
0	Write synchronization for CTRLA.ENABLE bit is complete.
1	Write synchronization for CTRLA.ENABLE bit is ongoing.

**Bit 0 – SWRST** Software Reset Synchronization Busy Status

Value	Description
0	Write synchronization for CTRLA.SWRST bit is complete.
1	Write synchronization for CTRLA.SWRST bit is ongoing.

### 21.12.9 Frequency Correction

**Name:**       FREQCORR  
**Offset:**     0x14  
**Reset:**       0x00  
**Property:**   PAC Write-Protection, Write-Synchronized

	7	6	5	4	3	2	1	0
	SIGN	VALUE[6:0]						
Access	R/W	R/W	R/W	R/W	R/W	R/W	R/W	R/W
Reset	0	0	0	0	0	0	0	0

#### Bit 7 – SIGN Correction Sign

Value	Description
0	The correction value is positive, i.e., frequency will be decreased.
1	The correction value is negative, i.e., frequency will be increased.

#### Bits 6:0 – VALUE[6:0] Correction Value

These bits define the amount of correction applied to the RTC prescaler.

Value	Description
0	Correction is disabled and the RTC frequency is unchanged.
1 – 127	The RTC frequency is adjusted according to the value.

# SAM D5x/E5x Family Data Sheet

## RTC – Real-Time Counter

### 21.12.10 Clock Value in Clock/Calendar mode (CTRLA.MODE=2)

**Name:** CLOCK  
**Offset:** 0x18  
**Reset:** 0x00000000  
**Property:** PAC Write-Protection, Write-Synchronized, Read-Synchronized

Bit	31	30	29	28	27	26	25	24
	YEAR[5:0]					MONTH[3:2]		
Access	R/W	R/W	R/W	R/W	R/W	R/W	R/W	R/W
Reset	0	0	0	0	0	0	0	0
Bit	23	22	21	20	19	18	17	16
	MONTH[1:0]		DAY[4:0]				HOUR[4:4]	
Access	R/W	R/W	R/W	R/W	R/W	R/W	R/W	R/W
Reset	0	0	0	0	0	0	0	0
Bit	15	14	13	12	11	10	9	8
	HOUR[3:0]				MINUTE[5:2]			
Access	R/W	R/W	R/W	R/W	R/W	R/W	R/W	R/W
Reset	0	0	0	0	0	0	0	0
Bit	7	6	5	4	3	2	1	0
	MINUTE[1:0]		SECOND[5:0]					
Access	R/W	R/W	R/W	R/W	R/W	R/W	R/W	R/W
Reset	0	0	0	0	0	0	0	0

#### Bits 31:26 – YEAR[5:0] Year

The year offset with respect to the reference year (defined in software).  
The year is considered a leap year if YEAR[1:0] is zero.

#### Bits 25:22 – MONTH[3:0] Month

1 – January  
2 – February  
...  
12 – December

#### Bits 21:17 – DAY[4:0] Day

Day starts at 1 and ends at 28, 29, 30, or 31, depending on the month and year.

#### Bits 16:12 – HOUR[4:0] Hour

When CTRLA.CLKREP=0, the Hour bit group is in 24-hour format, with values 0-23. When CTRLA.CLKREP=1, HOUR[3:0] has values 1-12, and HOUR[4] represents AM (0) or PM (1).

#### Bits 11:6 – MINUTE[5:0] Minute

0 – 59

#### Bits 5:0 – SECOND[5:0] Second

0 – 59

# SAM D5x/E5x Family Data Sheet

## RTC – Real-Time Counter

### 21.12.11 Alarm n Value in Clock/Calendar mode (CTRLA.MODE=2)

**Name:** ALARM  
**Offset:** 0x20 + n\*0x08 [n=0..1]  
**Reset:** 0x00000000  
**Property:** PAC Write-Protection, Write-Synchronized

The 32-bit value of ALARMA<sub>n</sub> is continuously compared with the 32-bit CLOCK value, based on the masking set by MASK<sub>n</sub>.SEL. When a match occurs, the Alarm n interrupt flag in the Interrupt Flag Status and Clear register (INTFLAG.ALARMA<sub>n</sub>) is set on the next counter cycle, and the counter is cleared if CTRLA.MATCHCLR is '1'.

Bit	31	30	29	28	27	26	25	24
	YEAR[5:0]					MONTH[3:2]		
Access	R/W	R/W	R/W	R/W	R/W	R/W	R/W	R/W
Reset	0	0	0	0	0	0	0	0
Bit	23	22	21	20	19	18	17	16
	MONTH[1:0]		DAY[4:0]				HOUR[4:4]	
Access	R/W	R/W	R/W	R/W	R/W	R/W	R/W	R/W
Reset	0	0	0	0	0	0	0	0
Bit	15	14	13	12	11	10	9	8
	HOUR[3:0]				MINUTE[5:2]			
Access	R/W	R/W	R/W	R/W	R/W	R/W	R/W	R/W
Reset	0	0	0	0	0	0	0	0
Bit	7	6	5	4	3	2	1	0
	MINUTE[1:0]		SECOND[5:0]					
Access	R/W	R/W	R/W	R/W	R/W	R/W	R/W	R/W
Reset	0	0	0	0	0	0	0	0

**Bits 31:26 – YEAR[5:0] Year**

The alarm year. Years are only matched if MASK<sub>n</sub>.SEL is 6

**Bits 25:22 – MONTH[3:0] Month**

The alarm month. Months are matched only if MASK<sub>n</sub>.SEL is greater than 4.

**Bits 21:17 – DAY[4:0] Day**

The alarm day. Days are matched only if MASK<sub>n</sub>.SEL is greater than 3.

**Bits 16:12 – HOUR[4:0] Hour**

The alarm hour. Hours are matched only if MASK<sub>n</sub>.SEL is greater than 2.

**Bits 11:6 – MINUTE[5:0] Minute**

The alarm minute. Minutes are matched only if MASK<sub>n</sub>.SEL is greater than 1.

**Bits 5:0 – SECOND[5:0] Second**

The alarm second. Seconds are matched only if MASK<sub>n</sub>.SEL is greater than 0.

### 21.12.12 Alarm n Mask in Clock/Calendar mode (CTRLA.MODE=2)

**Name:** MASK  
**Offset:** 0x24 + n\*0x08 [n=0..1]  
**Reset:** 0x00  
**Property:** PAC Write-Protection, Write-Synchronized

	7	6	5	4	3	2	1	0	
							SEL[2:0]		
Access							R/W	R/W	R/W
Reset							0	0	0

#### Bits 2:0 – SEL[2:0] Alarm Mask Selection

These bits define which bit groups of Alarm n are valid.

Value	Name	Description
0x0	OFF	Alarm Disabled
0x1	SS	Match seconds only
0x2	MMSS	Match seconds and minutes only
0x3	HHMMSS	Match seconds, minutes, and hours only
0x4	DDHHMMSS	Match seconds, minutes, hours, and days only
0x5	MMDDHHMMSS	Match seconds, minutes, hours, days, and months only
0x6	YYMMDDHHMMSS	Match seconds, minutes, hours, days, months, and years
0x7	-	Reserved

# SAM D5x/E5x Family Data Sheet

## RTC – Real-Time Counter

### 21.12.13 General Purpose n

**Name:** GPn  
**Offset:** 0x40 + n\*0x04 [n=0..3]  
**Reset:** 0x00000000  
**Property:** -

Bit	31	30	29	28	27	26	25	24
	GP[31:24]							
Access	R/W	R/W	R/W	R/W	R/W	R/W	R/W	R/W
Reset	0	0	0	0	0	0	0	0
Bit	23	22	21	20	19	18	17	16
	GP[23:16]							
Access	R/W	R/W	R/W	R/W	R/W	R/W	R/W	R/W
Reset	0	0	0	0	0	0	0	0
Bit	15	14	13	12	11	10	9	8
	GP[15:8]							
Access	R/W	R/W	R/W	R/W	R/W	R/W	R/W	R/W
Reset	0	0	0	0	0	0	0	0
Bit	7	6	5	4	3	2	1	0
	GP[7:0]							
Access	R/W	R/W	R/W	R/W	R/W	R/W	R/W	R/W
Reset	0	0	0	0	0	0	0	0

#### Bits 31:0 – GP[31:0] General Purpose

These bits are for user-defined general purpose use, see [21.6.8.4 General Purpose Registers](#).



# SAM D5x/E5x Family Data Sheet

## RTC – Real-Time Counter

### 21.12.14 Tamper Control

**Name:** TAMPCTRL  
**Offset:** 0x60  
**Reset:** 0x00000000  
**Property:** PAC Write-Protection, Enable-Protected

	Bit	31	30	29	28	27	26	25	24
					DEBNC4	DEBNC3	DEBNC2	DEBNC1	DEBNC0
Access									
Reset					0	0	0	0	0
	Bit	23	22	21	20	19	18	17	16
					TAMLVL4	TAMLVL3	TAMLVL2	TAMLVL1	TAMLVL0
Access									
Reset					0	0	0	0	0
	Bit	15	14	13	12	11	10	9	8
								IN4ACT[1:0]	
Access									
Reset								0	0
	Bit	7	6	5	4	3	2	1	0
		IN3ACT[1:0]		IN2ACT[1:0]		IN1ACT[1:0]		IN0ACT[1:0]	
Access									
Reset		0	0	0	0	0	0	0	0

**Bits 24, 25, 26, 27, 28 – DEBNC** Debounce Enable of Tamper Input INn

**Note:** Debounce feature does not apply to the Active Layer Protection mode (TAMPCTRL.INACT = ACTL).

Value	Description
0	Debouncing is disabled for Tamper input INn
1	Debouncing is enabled for Tamper input INn

**Bits 16, 17, 18, 19, 20 – TAMLVL** Tamper Level Select of Tamper Input INn

**Note:** Tamper Level feature does not apply to the Active Layer Protection mode (TAMPCTRL.INACT = ACTL).

Value	Description
0	A falling edge condition will be detected on Tamper input INn.
1	A rising edge condition will be detected on Tamper input INn.

**Bits 0:1, 2:3, 4:5, 6:7, 8:9 – INACT** Tamper Channel n Action

These bits determine the action taken by Tamper Channel n.

Value	Name	Description
0x0	OFF	Off (Disabled)
0x1	WAKE	Wake and set Tamper flag
0x2	CAPTURE	Capture timestamp and set Tamper flag

# SAM D5x/E5x Family Data Sheet

## RTC – Real-Time Counter

---

---

Value	Name	Description
0x3	ACTL	Compare RTC signal routed between INn and OUT pins . When a mismatch occurs, capture timestamp and set Tamper flag

# SAM D5x/E5x Family Data Sheet

## RTC – Real-Time Counter

### 21.12.15 Timestamp Value

**Name:**       TIMESTAMP  
**Offset:**     0x64  
**Reset:**       0  
**Property:**   R

Bit	31	30	29	28	27	26	25	24
	YEAR[5:0]					MONTH[3:2]		
Access	R	R	R	R	R	R	R	R
Reset	0	0	0	0	0	0	0	0
Bit	23	22	21	20	19	18	17	16
	MONTH[1:0]		DAY[4:0]				HOUR[4:4]	
Access	R	R	R	R	R	R	R	R
Reset	0	0	0	0	0	0	0	0
Bit	15	14	13	12	11	10	9	8
	HOUR[3:0]				MINUTE[5:2]			
Access	R	R	R	R	R	R	R	R
Reset	0	0	0	0	0	0	0	0
Bit	7	6	5	4	3	2	1	0
	MINUTE[1:0]		SECOND[5:0]					
Access	R	R	R	R	R	R	R	R
Reset	0	0	0	0	0	0	0	0

#### Bits 31:26 – YEAR[5:0] Year

The year value is captured by the TIMESTAMP when a tamper condition occurs.

#### Bits 25:22 – MONTH[3:0] Month

The month value is captured by the TIMESTAMP when a tamper condition occurs.

#### Bits 21:17 – DAY[4:0] Day

The day value is captured by the TIMESTAMP when a tamper condition occurs.

#### Bits 16:12 – HOUR[4:0] Hour

The hour value is captured by the TIMESTAMP when a tamper condition occurs.

#### Bits 11:6 – MINUTE[5:0] Minute

The minute value is captured by the TIMESTAMP when a tamper condition occurs.

#### Bits 5:0 – SECOND[5:0] Second

The second value is captured by the TIMESTAMP when a tamper condition occurs.

### 21.12.16 Tamper ID

**Name:** TAMPID  
**Offset:** 0x68  
**Reset:** 0x00000000

	Bit	31	30	29	28	27	26	25	24	
		TAMPEVT								
Access		R/W								
Reset		0								
	Bit	23	22	21	20	19	18	17	16	
Access										
Reset										
	Bit	15	14	13	12	11	10	9	8	
Access										
Reset										
	Bit	7	6	5	4	3	2	1	0	
						TAMPID4	TAMPID3	TAMPID2	TAMPID1	TAMPID0
Access						R/W	R/W	R/W	R/W	R/W
Reset						0	0	0	0	0

**Bit 31 – TAMPEVT** Tamper Event Detected

Writing a '0' to this bit has no effect. Writing a '1' to this bit clears the tamper detection bit.

Value	Description
0	A tamper input event has not been detected
1	A tamper input event has been detected

**Bits 0, 1, 2, 3, 4 – TAMPID** Tamper on Channel n Detected

Writing a '0' to this bit has no effect. Writing a '1' to this bit clears the tamper detection bit.

Value	Description
0	A tamper condition has not been detected on Channel n
1	A tamper condition has been detected on Channel n

# SAM D5x/E5x Family Data Sheet

## RTC – Real-Time Counter

### 21.12.17 Backup n

**Name:** BKUP  
**Offset:** 0x80 + n\*0x04 [n=0..7]  
**Reset:** 0x00000000  
**Property:** PAC Write-Protection

Bit	31	30	29	28	27	26	25	24
BKUP[31:24]								
Access	R/W	R/W	R/W	R/W	R/W	R/W	R/W	R/W
Reset	0	0	0	0	0	0	0	0
Bit	23	22	21	20	19	18	17	16
BKUP[23:16]								
Access	R/W	R/W	R/W	R/W	R/W	R/W	R/W	R/W
Reset	0	0	0	0	0	0	0	0
Bit	15	14	13	12	11	10	9	8
BKUP[15:8]								
Access	R/W	R/W	R/W	R/W	R/W	R/W	R/W	R/W
Reset	0	0	0	0	0	0	0	0
Bit	7	6	5	4	3	2	1	0
BKUP[7:0]								
Access	R/W	R/W	R/W	R/W	R/W	R/W	R/W	R/W
Reset	0	0	0	0	0	0	0	0

#### Bits 31:0 – BKUP[31:0] Backup

These bits are user-defined for general purpose use in the Backup domain.

## 22. DMAC – Direct Memory Access Controller

### 22.1 Overview

The Direct Memory Access Controller (DMAC) contains both a Direct Memory Access engine and a Cyclic Redundancy Check (CRC) engine. The DMAC can transfer data between memories and peripherals, and thus off-load these tasks from the CPU. It enables high data transfer rates with minimum CPU intervention, and frees up CPU time. With access to all peripherals, the DMAC can handle automatic transfer of data between communication modules.

The DMA part of the DMAC has several DMA channels which all can receive different types of transfer triggers to generate transfer requests from the DMA channels to the arbiter, see also the [Block Diagram](#). The arbiter will grant one DMA channel at a time to act as the active channel. When an active channel has been granted, the fetch engine of the DMAC will fetch a transfer descriptor from the SRAM and store it in the internal memory of the active channel, which will execute the data transmission.

An ongoing data transfer of an active channel can be interrupted by a higher prioritized DMA channel. The DMAC will write back the updated transfer descriptor from the internal memory of the active channel to SRAM, and grant the higher prioritized channel to start transfer as the new active channel. Once a DMA channel is done with its transfer, interrupts and events can be generated optionally.

The DMAC has four bus interfaces:

- The *data transfer bus* is used for performing the actual DMA transfer.
- The *AHB/APB Bridge bus* is used when writing and reading the I/O registers of the DMAC.
- The *descriptor fetch bus* is used by the fetch engine to fetch transfer descriptors before data transfer can be started or continued.
- The *write-back bus* is used to write the transfer descriptor back to SRAM.

All buses are AHB master interfaces but the AHB/APB Bridge bus, which is an APB slave interface.

Burst transfer options, buffered active channel to pre-fetch descriptors and advance quality of service features ensure low-latency transfers for high-speed peripherals or high-speed operations.

The CRC engine can be used by software to detect an accidental error in the transferred data and to take corrective action, such as requesting the data to be sent again or simply not using the incorrect data.

### 22.2 Features

- Data transfer from:
  - Peripheral to peripheral
  - Peripheral to memory
  - Memory to peripheral
  - Memory to memory
- Transfer trigger sources
  - Software
  - Events from Event System
  - Dedicated requests from peripherals
- SRAM based transfer descriptors

# SAM D5x/E5x Family Data Sheet

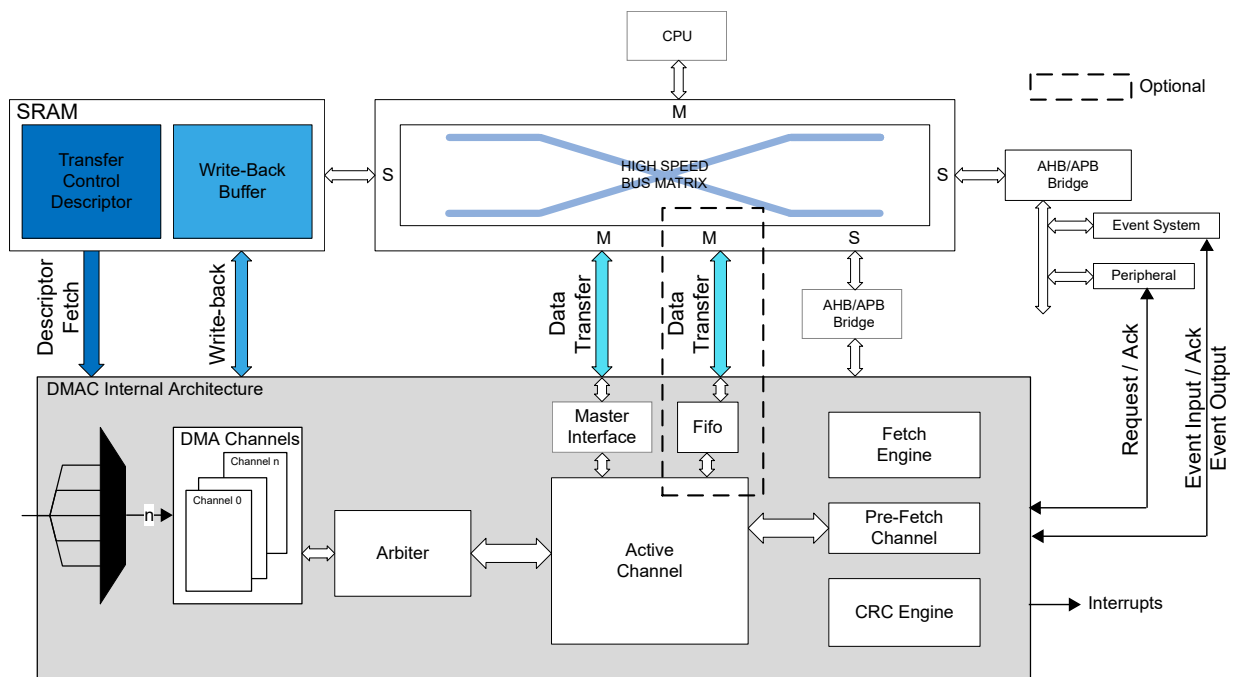
## DMAC – Direct Memory Access Controller

---

- Single transfer using one descriptor
- Multi-buffer or circular buffer modes by linking multiple descriptors
- Up to 32 channels
  - Enable 32 independent transfers
  - Automatic descriptor fetch for each channel
  - Suspend/resume operation support for each channel
- Flexible arbitration scheme
  - 4 configurable priority levels for each channel
  - Fixed or round-robin priority scheme within each priority level
- From 1 to 256KB data transfer in a single block transfer
- Multiple addressing modes
  - Static
  - Configurable increment scheme
- Optional interrupt generation
  - On block transfer complete
  - On error detection
  - On channel suspend
- 8 event inputs
  - One event input for each of the 8 least significant DMA channels
  - Can be selected to trigger normal transfers, periodic transfers or conditional transfers
  - Can be selected to suspend or resume channel operation
- 4 event outputs
  - One output event for each of the 4 least significant DMA channels
  - Selectable generation on AHB, block, or transaction transfer complete
- Error management supported by write-back function
  - Dedicated Write-Back memory section for each channel to store ongoing descriptor transfer
- CRC polynomial software selectable to
  - CRC-16 (CRC-CCITT)
  - CRC-32 (IEEE® 802.3)

### 22.3 Block Diagram

Figure 22-1. DMAC Block Diagram



### 22.4 Signal Description

Not applicable.

### 22.5 Product Dependencies

In order to use this peripheral, other parts of the system must be configured correctly, as described below.

#### 22.5.1 I/O Lines

Not applicable.

#### 22.5.2 Power Management

The DMAC will continue to operate in any Sleep mode where the selected source clock is running. The DMAC's interrupts can be used to wake-up the device from Sleep modes. Events connected to the event system can trigger other operations in the system without exiting Sleep modes. On hardware or software Reset, all registers are set to their Reset value.

#### Related Links

[18. PM – Power Manager](#)

#### 22.5.3 Clocks

An AHB clock (CLK\_DMACH\_AHB) is required to clock the DMAC. This clock can be configured in the Main Clock peripheral (MCLK) before using the DMAC, and the default state of CLK\_DMACH\_AHB can be found in the MCLK.AHBMASK register.

#### Related Links



### [15.6.2.6 Peripheral Clock Masking](#)

#### **22.5.4 DMA**

Not applicable.

#### **22.5.5 Interrupts**

The interrupt request line is connected to the interrupt controller. Using the DMAC interrupt requires the interrupt controller to be configured first.

##### **Related Links**

[10.2 Nested Vector Interrupt Controller](#)

#### **22.5.6 Events**

The events are connected to the event system.

#### **22.5.7 Debug Operation**

When the CPU is halted in Debug mode the DMAC will halt normal operation. The DMAC can be forced to continue operation during debugging. Refer to [22.8.6 DBGCTRL](#) for details.

#### **22.5.8 Register Access Protection**

All registers with write access can be write-protected optionally by the Peripheral Access Controller (PAC), except for the following registers:

- Interrupt Pending register (INTPEND)
- Channel Interrupt Flag Status and Clear register (CHINTFLAG)

Optional write protection by the Peripheral Access Controller (PAC) is denoted by the "PAC Write Protection" property in each individual register description.

PAC write protection does not apply to accesses through an external debugger.

#### **22.5.9 Analog Connections**

Not applicable.

## **22.6 Functional Description**

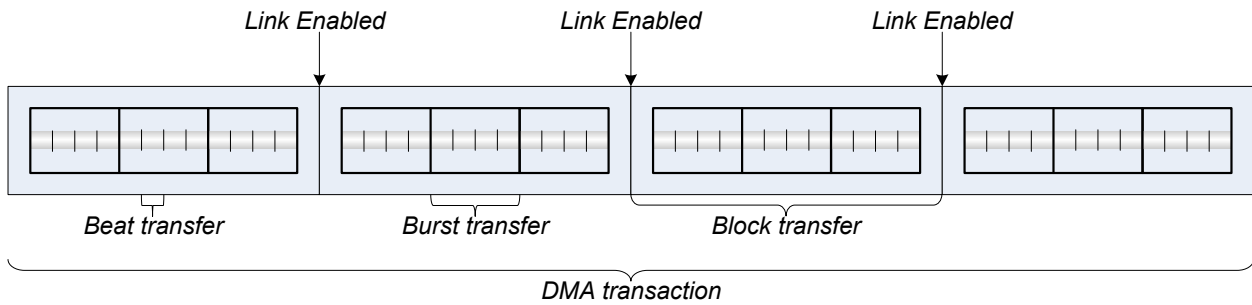
### **22.6.1 Principle of Operation**

The DMAC consists of a DMA module and a CRC module.

#### **22.6.1.1 DMA**

The DMAC can transfer data between memories and peripherals without interaction from the CPU. The data transferred by the DMAC are called transactions, and these transactions can be split into smaller data transfers. The following figure shows the relationship between the different transfer sizes:

**Figure 22-2. DMA Transfer Sizes**



- **Beat transfer:** The size of one data transfer bus access, and the size is selected by writing the Beat Size bit group in the Block Transfer Control register (BTCTRL.BEATSIZE)
- **Block transfer:** The amount of data one transfer descriptor can transfer, and the amount can range from 1 to 64k beats. A block transfer can be interrupted.
- **Transaction:** The DMAC can link several transfer descriptors by having the first descriptor pointing to the second and so forth, as shown in the figure above. A DMA transaction is the complete transfer of all blocks within a linked list.

A transfer descriptor describes how a block transfer should be carried out by the DMAC, and it must remain in SRAM. For further details on the transfer descriptor refer to [22.6.2.3 Transfer Descriptors](#).

The figure above shows several block transfers linked together, which are called linked descriptors. For further information about linked descriptors, refer to [22.6.3.1 Linked Descriptors](#).

A DMA transfer is initiated by an incoming transfer trigger on one of the DMA channels. This trigger can be configured to be either a software trigger, an event trigger, or one of the dedicated peripheral triggers. The transfer trigger will result in a DMA transfer request from the specific channel to the arbiter. If there are several DMA channels with pending transfer requests, the arbiter chooses which channel is granted access to become the active channel. The DMA channel granted access as the active channel will carry out the transaction as configured in the transfer descriptor. A current transaction can be interrupted by a higher prioritized channel, but will resume the block transfer when the according DMA channel is granted access as the active channel again.

For each beat transfer, an optional output event can be generated. For each block transfer, optional interrupts and an optional output event can be generated. When a transaction is completed, dependent of the configuration, the DMA channel will either be suspended or disabled.

### 22.6.1.2 CRC

The internal CRC engine supports two commonly used CRC polynomials: CRC-16 (CRC-CCITT) and CRC-32 (IEEE 802.3). It can be used on a selectable DMA channel, or on the I/O interface. Refer to [22.6.3.8 CRC Operation](#) for details.

## 22.6.2 Basic Operation

### 22.6.2.1 Initialization

#### DMAC Initialization

Before DMAC is enabled, it must be configured as defined below:

- The SRAM address of where the descriptor memory section is located must be written to the Description Base Address (BASEADDR) register.
- The SRAM address of where the write-back section should be located must be written to the Write-Back Memory Base Address (WRBADDR) register.

# SAM D5x/E5x Family Data Sheet

## DMAC – Direct Memory Access Controller

---

- Priority level x of the arbiter can be enabled by setting the Priority Level x Enable bit in the Control register (CTRL.LVLENx=1)

### DMA Channel Initialization

Before a DMA channel is enabled, the DMA channel and the corresponding first transfer descriptor must be configured, as defined below:

- DMA Channel Configuration:
  - The channel number of the DMA channel to configure must be written to the Channel Control A (CHCTRLA) register.
  - Trigger action must be selected by writing the Trigger Action bit field in the Channel Control A (CHCTRLA.TRIGACT) register.
  - Trigger source must be selected by writing the Trigger Source bit field in the Channel Control A (CHCTRLA.TRIGSRC) register.
- Transfer Descriptor
  - The size of each access of the data transfer bus must be selected by writing the Beat Size bit group in the Block Transfer Control (BTCTRL.BEATSIZE) register.
  - The transfer descriptor must be made valid by writing a one to the Valid bit in the Block Transfer Control (BTCTRL.VALID) register.
  - Number of beats in the block transfer must be selected by writing the Block Transfer Count (BTCNT) register.
  - Source address for the block transfer must be selected by writing the Block Transfer Source Address (SRCADDR) register.
  - Destination address for the block transfer must be selected by writing the Block Transfer Destination Address (DSTADDR) register.

### CRC Calculation

If CRC calculation is needed, the CRC engine must be configured before it is enabled, as described below:

- The CRC input source must be selected by writing the CRC Input Source bit group in the CRC Control (CRCCTRL.CRCSRC) register.
- The type of CRC calculation must be selected by writing the CRC Polynomial Type bit group in the CRC Control (CRCCTRL.CRCPOLY) register.
- If I/O is selected as input source, the beat size must be selected by writing the CRC Beat Size bit group in the CRC Control (CRCCTRL.CRCBEATSIZE) register.

### Register Properties

The following DMAC registers are enable-protected, that is, they can only be written when the DMAC is disabled (CTRL.DMAENABLE=0):

- The Descriptor Base Memory Address (BASEADDR) register
- The Write-Back Memory Base Address (WRBADDR) register

The following DMAC bit is enable-protected, that is, it can only be written when the DMAC and CRC are disabled (CTRL.DMAENABLE=0 and CRCCTRL.CRCSRC=0):

- The Software Reset bit in the Control (CTRL.SWRST) register

# SAM D5x/E5x Family Data Sheet

## DMAC – Direct Memory Access Controller

---

The following DMA channel bit is enable-protected, meaning that it can only be written when the corresponding DMA channel is disabled:

- The Channel Software Reset bit in the Channel Control A (CHCTRLA.SWRST) register

The following CRC registers are enable-protected, that is, they can only be written when the CRC is disabled (CRCCTRL.CRCSRC=0):

- The CRC Control (CRCCTRL) register
- CRC Checksum (CRCCHKSUM) register

Enable-protection is denoted by the 'Enable-Protected' property in the register description.

### 22.6.2.2 Enabling, Disabling, and Resetting

The DMAC is enabled by writing the DMA Enable bit in the Control (CTRL.DMAENABLE) register to '1'. The DMAC is disabled by writing a '0' to the CTRL.DMAENABLE register.

A DMA channel is enabled by writing the Enable bit in the Channel Control A register (CHCTRLA.ENABLE) to '1', after the corresponding channel ID to the channel is configured. A DMA channel is disabled by writing a '0' to CHCTRLAn.ENABLE.

The CRC is enabled by writing a value to the CRC Source bits in the Control register (CRCCTRL.CRCSRC). The CRC is disabled by writing a '0' to CRCCTRL.CRCSRC.

The DMAC is reset by writing a '1' to the Software Reset bit in the Control register (CTRL.SWRST) while the DMAC and CRC are disabled. All registers in the DMAC except DBGCTRL will be reset to their initial state.

A DMA channel is reset by writing a '1' to the Software Reset bit in the Channel Control A register (CHCTRLAn.SWRST), after the corresponding channel is configured. The channel registers will be reset to their initial state. The corresponding DMA channel must be disabled in order for the Reset to take effect.

### 22.6.2.3 Transfer Descriptors

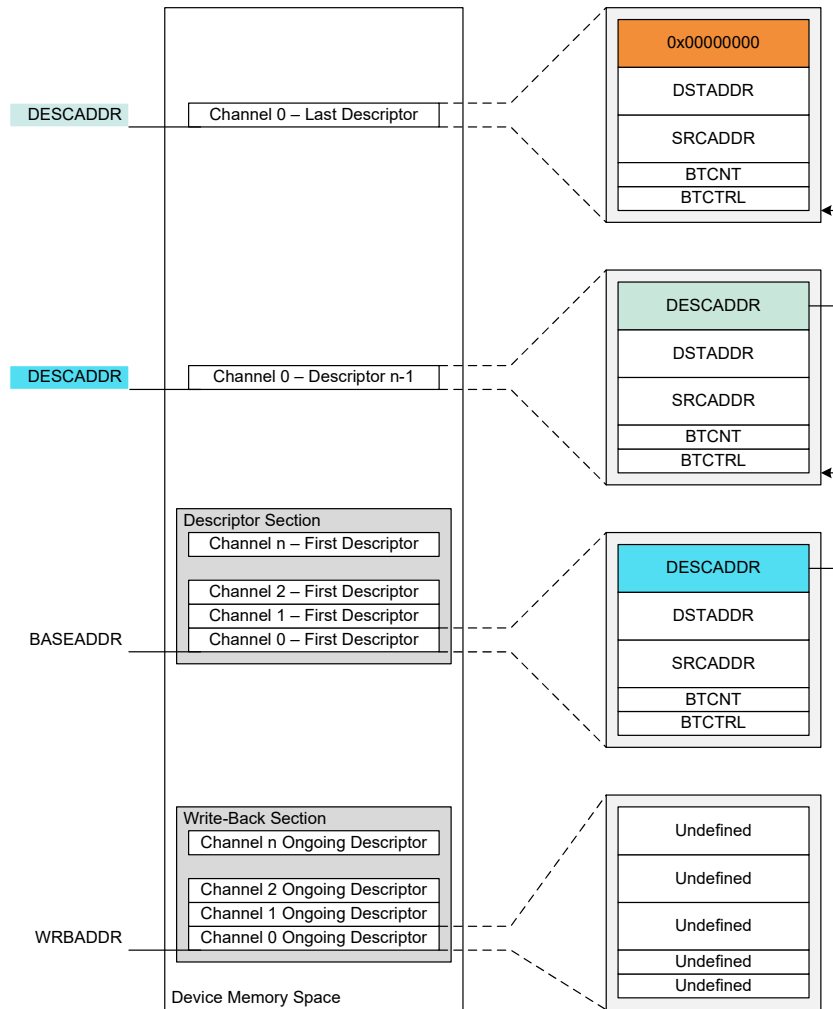
The transfer descriptors, together with the channel configurations, decide how a block transfer should be executed. Before a DMA channel is enabled (CHCTRLA.ENABLE is written to one) and receives a transfer trigger, its first transfer descriptor must be initialized and valid (BTCTRL.VALID). The first transfer descriptor describes the first block transfer of a transaction.

All transfer descriptors must reside in SRAM. The addresses stored in the Descriptor Memory Section Base Address (BASEADDR) and Write-Back Memory Section Base Address (WRBADDR) registers tell the DMAC where to find the descriptor memory section and the write-back memory section.

The descriptor memory section is where the DMAC expects to find the first transfer descriptors for all DMA channels. As BASEADDR points only to the first transfer descriptor of channel '0' (see figure below). All first transfer descriptors must be stored in a contiguous memory section, where the transfer descriptors must be ordered according to their channel number. For further details on linked descriptors, refer to [22.6.3.1 Linked Descriptors](#).

The write-back memory section is where the DMAC stores the transfer descriptors for the ongoing block transfers. WRBADDR points to the ongoing transfer descriptor of channel '0'. All ongoing transfer descriptors are stored in a contiguous memory section where the transfer descriptors are ordered according to their channel number. The figure below shows an example of linked descriptors on DMA channel '0'. For additional information on linked descriptors, refer to the [22.6.3.1 Linked Descriptors](#).

**Figure 22-3. Memory Sections**



The size of the descriptor and write-back memory sections are dependent on the number of the most significant enabled DMA channel  $m$ , as shown below:

$$Size = 128\text{bits} \cdot (m + 1)$$

For memory optimization, it is recommended to use the less significant DMA channels, if not all channels are required.

The descriptor and write-back memory sections can either be two separate memory sections, or they can share a memory section ( $\text{BASEADDR} = \text{WRBADDR}$ ). The benefit of having them in two separate sections, is that the same transaction for a channel can be repeated without having to modify the first transfer descriptor. In addition, the latency from fetching the first descriptor of a transaction to the first burst transfer is executed, is reduced.

### 22.6.2.4 Arbitration

If a DMA channel is enabled and not suspended when it receives a transfer trigger, it will send a transfer request to the arbiter. When the arbiter receives the transfer request it will include the DMA channel in the queue of channels having pending transfers, and the corresponding Pending Channel  $x$  bit in the Pending Channels registers ( $\text{PENDCH.PENDCHx}$ ) will be set. Depending on the arbitration scheme, the arbiter will choose which DMA channel will be the next active channel. The next transfer descriptor will be fetched from SRAM memory and stored internally in the Pre-Fetch Channel. The active channel is the

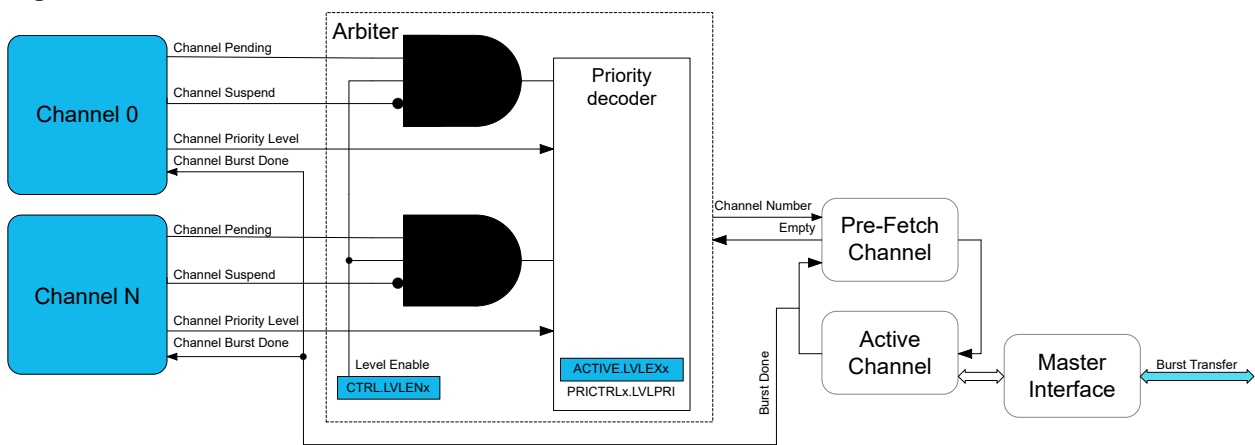
DMA channel being granted access to perform its next burst transfer. When the Active Channel has completed a burst transfer, the descriptor stored in the Pre-Fetch Channel is transferred to the Active Channel and a new burst will take place.

When the descriptor stored in the Pre-Fetch Channel is transferred to the Active Channel, the corresponding PENDCH.PENDCHx will be cleared. In the same way, depending on trigger action settings and if the upcoming burst transfer is the first for the transfer request or not, the corresponding Busy Channel x bit in the Busy Channels register (BUSYCH.BUSYCHx), will either be set or remain '1'. When the channel has performed its granted burst transfer(s) it will be either fed into the queue of channels with pending transfers, set to be waiting for a new transfer trigger, suspended, or disabled. This depends on the channel and block transfer configuration. If the DMA channel is set to wait for a new transfer trigger, suspended or disabled, the corresponding BUSYCH.BUSYCHx will be cleared.

If a DMA channel is suspended while it has a pending transfer, it will be removed from the queue of pending channels, but the corresponding PENDCH.PENDCHx will remain set. The status will also be indicated in CHINTFLAGn.SUSP. When the same DMA channel is resumed, it will be added to the queue of pending channels again.

If a DMA channel gets disabled (CHCTRLA.ENABLE=0) while it has a pending transfer, it will be removed from the queue of pending channels, and the corresponding PENDCH.PENDCHx will be cleared.

**Figure 22-4. Arbiter Overview**



### Priority Levels

When a channel level is pending or the channel is transferring data, the corresponding Level Executing bit is set in the Active Channel and Levels register (ACTIVE.LVLEXx).

Each DMA channel supports up to 4-level priority scheme. The number of supported priority levels will differ from one device family to another.

The priority level for a channel is configured by writing to the Channel Arbitration Level bit group in the Channel Priority Level register (CHPRILVL.PRILVL). As long as all priority levels are enabled, a channel with a higher priority level number will have priority over a channel with a lower priority level number. A priority level is enabled by writing the Priority Level x Enable bit in the Control register (CTRL.LVLENx) to '1', for the corresponding level.

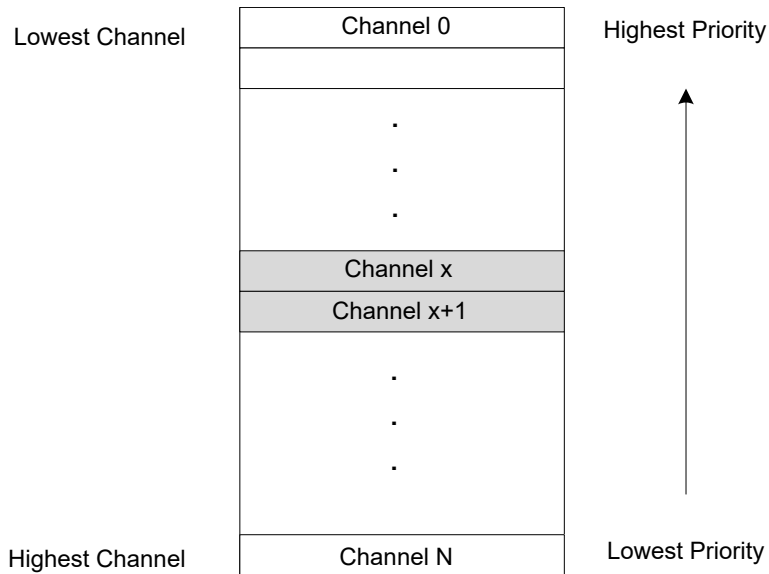
Within each priority level, the DMAC's arbiter can be configured to prioritize statically or dynamically. For the arbiter to perform static arbitration within a priority level, the Level X Round-Robin Scheduling Enable bit in the Priority Control x register (PRICTRL0.RRLVLENx) has to be written to '0'. When static arbitration is enabled (PRICTRL0.RRLVLENx is '0'), the arbiter will prioritize a low channel number over a high

# SAM D5x/E5x Family Data Sheet

## DMAC – Direct Memory Access Controller

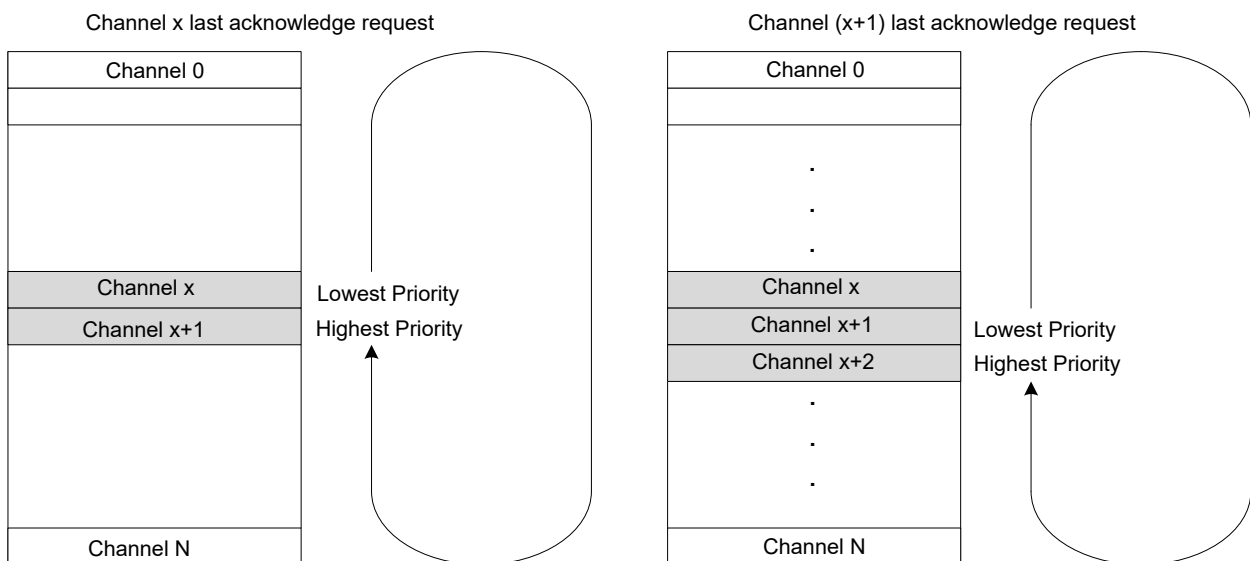
channel number as shown in [Static Priority Scheduling](#). When using the static scheme, there is a risk of high channel numbers never being granted access as the active channel. This can be avoided using a dynamic arbitration scheme.

**Figure 22-5. Static Priority Scheduling**



The dynamic arbitration scheme in the DMAC is round-robin. Round-robin arbitration is enabled by writing `PRICTRL0.RRLVLEN` to '1', for a given priority level  $x$ . With the round-robin scheme, the channel number of the last channel being granted access will have the lowest priority the next time the arbiter has to grant access to a channel within the same priority level, as shown in [Figure 22-6](#). The channel number of the last channel being granted access as the active channel is stored in the Level  $x$  Channel Priority Number bit group in the Priority Control 0 register (`PRICTRL0.LVLPRIx`) for the corresponding priority level.

**Figure 22-6. Dynamic (Round-Robin) Priority Scheduling**



### 22.6.2.5 Data Transmission

Before the DMAC can perform a data transmission, a DMA channel has to be configured and enabled, its corresponding transfer descriptor has to be initialized, and the arbiter has to grant the DMA channel access as the active channel.

Once the arbiter has granted a DMA channel access as the active channel (refer to DMA Block Diagram section) the transfer descriptor for the DMA channel will be fetched from SRAM using the fetch bus, and stored in the internal memory for the active channel. For a new block transfer, the transfer descriptor will be fetched from the descriptor memory section ([BASEADDR](#)); For an ongoing block transfer, the descriptor will be fetched from the write-back memory section ([WRBADDR](#)). By using the data transfer bus, the DMAC will read the data from the current source address and write it to the current destination address. For further details on how the current source and destination addresses are calculated, refer to the section on [Addressing](#).

The arbitration procedure is performed after each burst transfer. If the current DMA channel is granted access again, the block transfer counter ([BTCNT](#)) of the internal transfer descriptor will be decremented by the number of beats in a burst transfer, the optional output event Beat will be generated if configured and enabled, and the active channel will perform a new burst transfer. If a different DMA channel than the current active channel is granted access, the block transfer counter value will be written to the write-back section before the transfer descriptor of the newly granted DMA channel is fetched into the internal memory of the active channel.

When a block transfer has come to its end ([BTCNT](#) is zero), the Valid bit in the Block Transfer Control register will be cleared ([BTCTRL.VALID=0](#)) before the entire transfer descriptor is written to the write-back memory. The optional interrupts, Channel Transfer Complete and Channel Suspend, and the optional output event Block, will be generated if configured and enabled. After the last block transfer in a transaction, the Next Descriptor Address register ([DESCADDR](#)) will hold the value 0x00000000, and the DMA channel will either be suspended or disabled, depending on the configuration in the Block Action bit group in the Block Transfer Control register ([BTCTRL.BLOCKACT](#)). If the transaction has further block transfers pending, [DESCADDR](#) will hold the SRAM address to the next transfer descriptor to be fetched. The DMAC will fetch the next descriptor into the internal memory of the active channel and write its content to the write-back section for the channel, before the arbiter gets to choose the next active channel.

#### Related Links

[22.3 Block Diagram](#)

### 22.6.2.6 Transfer Triggers and Actions

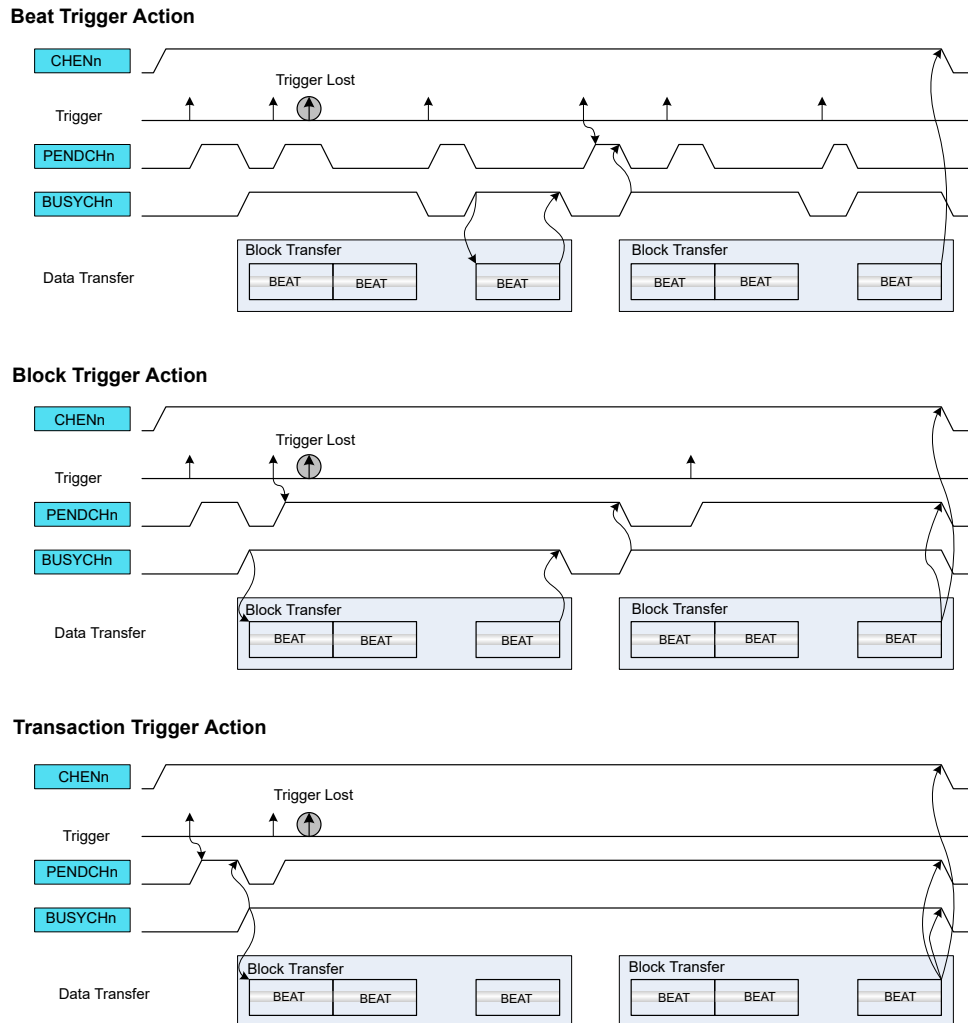
A DMA transfer through a DMA channel can be started only when a DMA transfer request is detected, and the DMA channel has been granted access to the DMA. A transfer request can be triggered from software, from a peripheral, or from an event. There are dedicated Trigger Source selections for each DMA Channel n Control A ([CHCTRLn.TRIGSRC](#)).

The trigger actions are available in the Trigger Action bit group in the Channel n Control A register ([CHCTRLn.TRIGACT](#)). By default, a trigger generates a request for a block transfer operation. If a single descriptor is defined for a channel, the channel is automatically disabled when a block transfer has been completed. If a list of linked descriptors is defined for a channel, the channel is automatically disabled when the last descriptor in the list is executed. As long as the list still has descriptors to execute, the channel will be waiting for the next block transfer trigger. When enabled again, the channel will wait for the next block transfer trigger. The trigger actions can also be configured to generate a request for a burst transfer ([CHCTRLn.TRIGACT=0x2](#)) or transaction transfer ([CHCTRLn.TRIGACT=0x3](#)) instead of a block transfer ([CHCTRLn.TRIGACT=0x0](#)).



The following figure shows an example where triggers are used with two linked block descriptors.

**Figure 22-7. Trigger Action and Transfers**



If the trigger source generates a transfer request for a channel during an ongoing transfer, the new transfer request will be kept pending (CHSTATUSn.PEND=1), and the new transfer can start after the ongoing one is done. Only one pending transfer can be kept per channel. If the trigger source generates more transfer requests while one is already pending, the additional ones will be lost. All channels pending status flags are also available in the Pending Channels register (PENDCH).

When the transfer starts, the corresponding Channel Busy status flag is set in Channel n Status register (CHSTATUSn.BUSY). When the trigger action is complete, the Channel Busy status flag is cleared. All channel busy status flags are also available in the Busy Channels register (BUSYCH) in DMAC.

### 22.6.2.7 Addressing

Each block transfer needs to have both a source address and a destination address defined. The source address is set by writing the Transfer Source Address ([SRCADDR](#)) register, the destination address is set by writing the Transfer Destination Address ([SRCADDR](#)) register.

The addressing of this DMAC module can be static or incremental, for either source or destination of a block transfer, or both.

# SAM D5x/E5x Family Data Sheet

## DMAC – Direct Memory Access Controller

Incrementation for the source address of a block transfer is enabled by writing the Source Address Incrementation Enable bit in the Block Transfer Control register (`BTCTRL.SRCINC=1`). The step size of the incrementation is configurable and can be chosen by writing the Step Selection bit in the Block Transfer Control register (`BTCTRL.STEPSEL=1`) and writing the desired step size in the Address Increment Step Size bit group in the Block Transfer Control register (`BTCTRL.STEPSIZE`). If `BTCTRL.STEPSEL=0`, the step size for the source incrementation will be the size of one beat.

When source address incrementation is configured (`BTCTRL.SRCINC=1`), `SRCADDR` is calculated as follows:

If `BTCTRL.STEPSEL=1`:

$$\text{SRCADDR} = \text{SRCADDR}_{\text{START}} + \text{BTCNT} \cdot (\text{BEATSIZE} + 1) \cdot 2^{\text{STEPSIZE}}$$

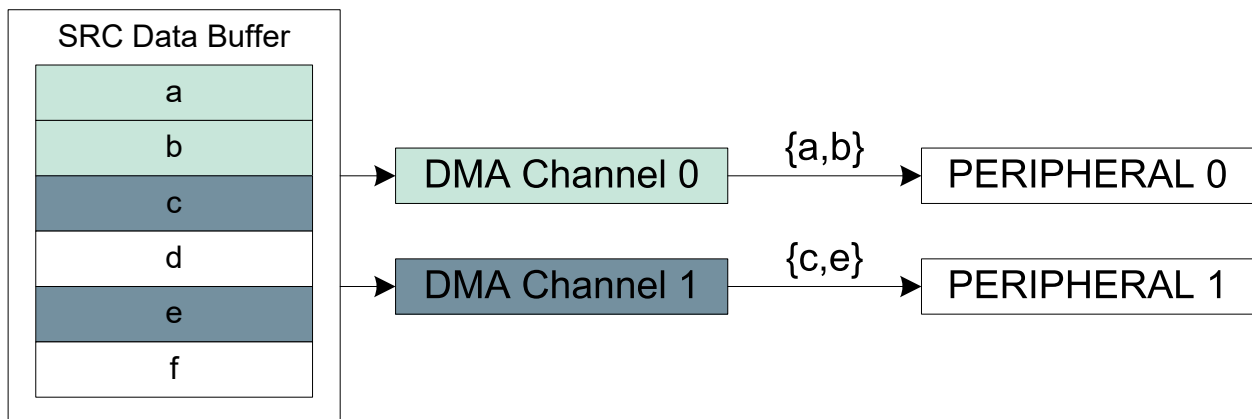
If `BTCTRL.STEPSEL=0`:

$$\text{SRCADDR} = \text{SRCADDR}_{\text{START}} + \text{BTCNT} \cdot (\text{BEATSIZE} + 1)$$

- `SRCADDRSTART` is the source address of the first beat transfer in the block transfer
- `BTCNT` is the initial number of beats remaining in the block transfer
- `BEATSIZE` is the configured number of bytes in a beat
- `STEPSIZE` is the configured number of beats for each incrementation

The following figure shows an example where DMA channel 0 is configured to increment the source address by one beat after each beat transfer (`BTCTRL.SRCINC=1`), and DMA channel 1 is configured to increment the source address by two beats (`BTCTRL.SRCINC=1`, `BTCTRL.STEPSEL=1`, and `BTCTRL.STEPSIZE=0x1`). As the destination address for both channels are peripherals, destination incrementation is disabled (`BTCTRL.DSTINC=0`).

**Figure 22-8. Source Address Increment**



Incrementation for the destination address of a block transfer is enabled by setting the Destination Address Incrementation Enable bit in the Block Transfer Control register (`BTCTRL.DSTINC=1`). The step size of the incrementation is configurable by clearing `BTCTRL.STEPSEL=0` and writing `BTCTRL.STEPSIZE` to the desired step size. If `BTCTRL.STEPSEL=1`, the step size for the destination incrementation will be the size of one beat.

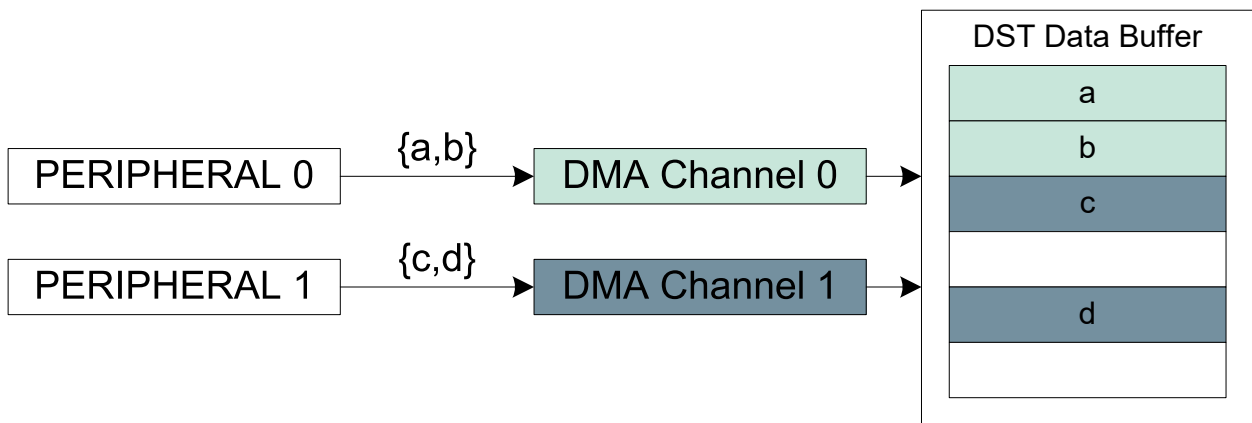
When the destination address incrementation is configured (`BTCTRL.DSTINC=1`), `DSTADDR` must be set and calculated as follows:

$DSTADDR = DSTADDR_{START} + BTCNT \cdot (BEATSIZE + 1) \cdot 2^{STEP\!SIZE}$	where <code>BTCTRL.STEPSEL</code> is zero
$DSTADDR = DSTADDR_{START} + BTCNT \cdot (BEATSIZE + 1)$	where <code>BTCTRL.STEPSEL</code> is one

- $DSTADDR_{START}$  is the destination address of the first beat transfer in the block transfer
- $BTCNT$  is the initial number of beats remaining in the block transfer
- $BEATSIZE$  is the configured number of bytes in a beat
- $STEP\!SIZE$  is the configured number of beats for each incrementation

The following figure shows an example where DMA channel 0 is configured to increment destination address by one beat (`BTCTRL.DSTINC=1`) and DMA channel 1 is configured to increment destination address by two beats (`BTCTRL.DSTINC=1`, `BTCTRL.STEPSEL=0`, and `BTCTRL.STEP\!SIZE=0x1`). As the source address for both channels are peripherals, source incrementation is disabled (`BTCTRL.SRCINC=0`).

**Figure 22-9. Destination Address Increment**



### 22.6.2.8 Internal FIFO

To improve the bandwidth, the DMAC can support FIFO operation. When single-beat burst configuration is selected (`CHCTRLx.BURSTLEN = SINGLE`), the channel waits until the FIFO can transmit or accept a single beat transfer before it requests a bus access to write to the destination address. In all other cases, the channel waits until the FIFO threshold is reached before it requests a bus access to write to the destination address. The threshold is configurable and can be set by writing the `THRESHOLD` bits in the Channel x Control A register.

If the DMAC completes the read operations before the threshold is reached, the write to the destination is automatically enabled. If the FIFO is empty and the read from source is ongoing, the DMA will wait again until the FIFO threshold is reached before it requests a bus access to write the destination.

### 22.6.2.9 Error Handling

If a bus error is received from an AHB slave during a DMA data transfer, the corresponding active channel is disabled and the corresponding Channel Transfer Error Interrupt flag in the Channel Interrupt Status and Clear register (`CHINTFLAG.TERR`) is set. If enabled, the optional transfer error interrupt is generated. The transfer counter will not be decremented and its current value is written-back in the write-back memory section before the channel is disabled.

When the DMAC fetches an invalid descriptor (`BTCTRL.VALID=0`) or when the channel is resumed and the DMA fetches the next descriptor with null address (`DESCADDR=0x00000000`), the corresponding channel operation is suspended, the Channel Suspend Interrupt Flag in the Channel Interrupt Flag Status

and Clear register (CHINTFLAG.SUSP) is set, and the Channel Fetch Error bit in the Channel Status register (CHSTATUS.FERR) is set. If enabled, the optional suspend interrupt is generated.

### 22.6.3 Additional Features

#### 22.6.3.1 Linked Descriptors

A transaction can consist of either a single block transfer or of several block transfers. When a transaction consists of several block transfers it is done with the help of linked descriptors.

Figure 22-3 illustrates how linked descriptors work. When the first block transfer is completed on DMA channel 0, the DMAC fetches the next transfer descriptor, which is pointed to by the value stored in the Next Descriptor Address (**DESCADDR**) register of the first transfer descriptor. Fetching the next transfer descriptor (**DESCADDR**) is continued until the last transfer descriptor. When the block transfer for the last transfer descriptor is executed and **DESCADDR=0x00000000**, the transaction is terminated. For further details on how the next descriptor is fetched from SRAM, refer to section 22.6.2.5 [Data Transmission](#).

##### 22.6.3.1.1 Adding Descriptor to the End of a List

To add a new descriptor at the end of the descriptor list, create the descriptor in SRAM, with **DESCADDR=0x00000000** indicating that it is the new last descriptor in the list, and modify the **DESCADDR** value of the current last descriptor to the address of the newly created descriptor.

##### 22.6.3.1.2 Modifying a Descriptor in a List

In order to add descriptors to a linked list, the following actions must be performed:

1. Enable the Suspend interrupt for the DMA channel.
2. Enable the DMA channel.
3. Reserve memory space in SRAM to configure a new descriptor.
4. Configure the new descriptor:
  - Set the next descriptor address (**DESCADDR**)
  - Set the destination address (**DSTADDR**)
  - Set the source address (**SRCADDR**)
  - Configure the block transfer control (**BTCTRL**) including
    - Optionally enable the suspend block action
    - Set the descriptor VALID bit
5. Clear the VALID bit for the existing list and for the descriptor which has to be updated.
6. Read **DESCADDR** from the write-back memory.
  - If the DMA has not already fetched the descriptor that requires changes (i.e., **DESCADDR** is wrong):
    - Update the **DESCADDR** location of the descriptor from the list
    - Optionally clear the suspend block action
    - Set the descriptor VALID bit to '1'
    - Optionally enable the Resume Software command
  - If the DMA is executing the same descriptor as the one that requires changes:
    - Set the Channel Suspend Software command and wait for the suspend interrupt
    - Update the next descriptor address (**DESCADDR**) in the write-back memory
    - Clear the interrupt sources and set the Resume Software command
    - Update the **DESCADDR** location of the descriptor from the list
    - Optionally clear the suspend block action
    - Set the descriptor VALID bit to '1'

7. Go to step 4 if needed.

### 22.6.3.1.3 Adding a Descriptor Between Existing Descriptors

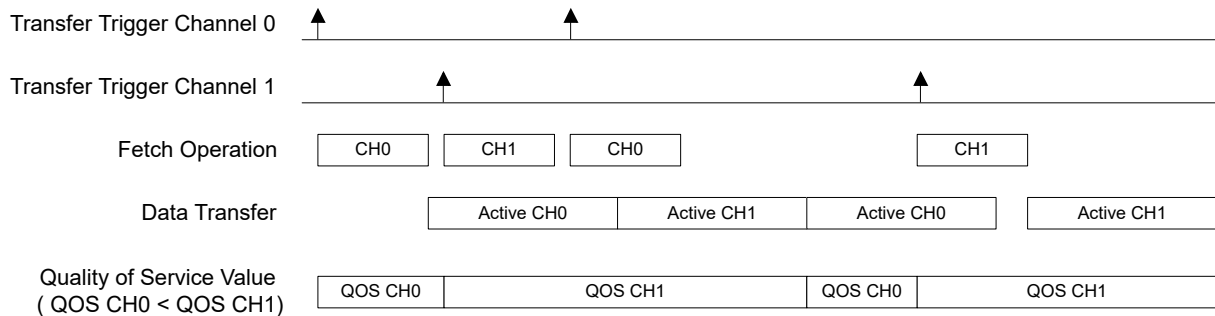
To insert a new descriptor 'C' between two existing descriptors ('A' and 'B'), the descriptor currently executed by the DMA must be identified.

1. If DMA is executing descriptor B, descriptor C cannot be inserted.
2. If DMA has not started to execute descriptor A, follow the steps:
  - 2.1. Set the descriptor A VALID bit to '0'.
  - 2.2. Set the **DESCADDR** value of descriptor A to point to descriptor C instead of descriptor B.
  - 2.3. Set the **DESCADDR** value of descriptor C to point to descriptor B.
  - 2.4. Set the descriptor A VALID bit to '1'.
3. If DMA is executing descriptor A:
  - 3.1. Apply the software suspend command to the channel and
  - 3.2. Perform steps 2.1 through 2.4.
  - 3.3. Apply the software resume command to the channel.

### 22.6.3.2 Transfer Quality of Service

Each priority level group has dedicated quality of service settings. The setting can be written in the corresponding Quality of Service bit group in the Priority Control x register (PRICTRL0.QOSn).

**Figure 22-10. Quality of Service**



When a channel is stored in the Pre-Fetch or Active Channel, the corresponding PRICTRLx.QOS bits value is stored in the respective channel. As shown in Quality of Service, the DMAC will select the highest QOS value between Active and Pre-Fetch channels. This value will apply to all DMAC buses.

### 22.6.3.3 Channel Suspend

The channel operation can be suspended at any time by software by writing a '1' to the Suspend command in the Command bit field of Channel Control B register (CHCTRLB.CMD). After the ongoing burst transfer is completed, the channel operation is suspended and the suspend command is automatically cleared.

When suspended, the Channel Suspend Interrupt flag in the Channel Interrupt Status and Clear register is set (CHINTFLAG.SUSP=1) and the optional suspend interrupt is generated.

By configuring the block action to suspend by writing Block Action bit group in the Block Transfer Control register (BTCTRL.BLOCKACT is 0x2 or 0x3), the DMA channel will be suspended after it has completed a block transfer. The DMA channel will be kept enabled and will be able to receive transfer triggers, but it will be removed from the arbitration scheme.

If an invalid transfer descriptor (BTCTRL.VALID=0) is fetched from SRAM, the DMA channel will be suspended, and the Channel Fetch Error bit in the Channel Status register(CHASTATUS.FERR) will be set.

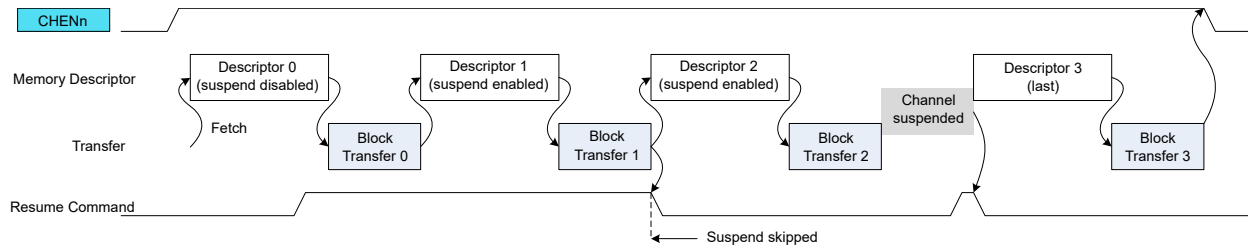
**Note:** Only enabled DMA channels can be suspended. If a channel is disabled when it is attempted to be suspended, the internal suspend command will be ignored.

For more details on transfer descriptors, refer to section [22.6.2.3 Transfer Descriptors](#).

### 22.6.3.4 Channel Resume and Next Suspend Skip

A channel operation can be resumed by software by setting the Resume command in the Command bit field of the Channel Control B register (CHCTRLB.CMD). If the channel is already suspended, the channel operation resumes from where it previously stopped when the Resume command is detected. When the Resume command is issued before the channel is suspended, the next suspend action is skipped and the channel continues the normal operation.

**Figure 22-11. Channel Suspend/Resume Operation**



### 22.6.3.5 Event Input Actions

The event input actions are available only on the least significant DMA channels. For details on channels with event input support, refer to the [Event System](#) documentation.

Before using event input actions, the event controller must be configured first according to the following table, and the Channel Event Input Enable bit in the Channel Event Control register (CHEVCTRL.EVIE) must be written to '1'. Refer also to [22.6.6 Events](#).

**Table 22-1. Event Input Action**

Action	CHEVCTRL.EVACT	CHCTRLA.TRIGSRC
None	NOACT	-
Normal Transfer	TRIG	DISABLE
Conditional Transfer on Strobe	TRIG	Any peripheral
Conditional Transfer	CTRIG	
Conditional Block Transfer	CBLOCK	
Channel Suspend	SUSPEND	
Channel Resume	RESUME	
Skip Next Block Suspend	SSKIP	
Increase priority	INCPRI	

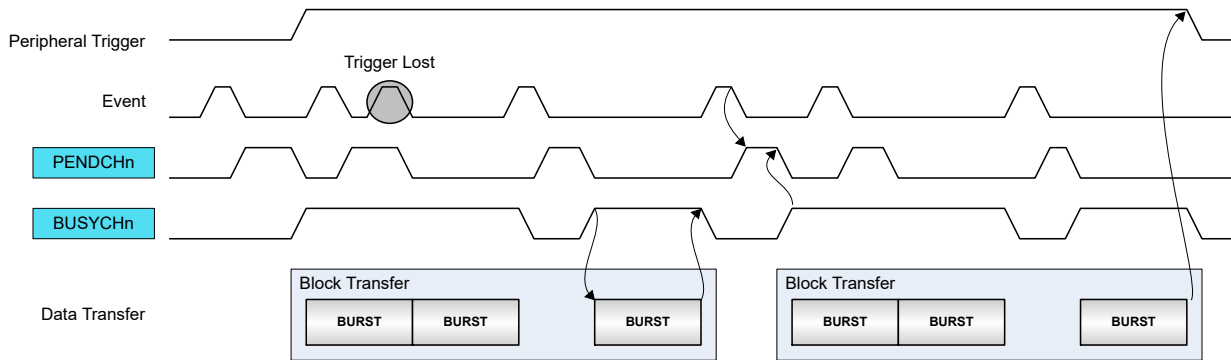
#### Normal Transfer

The event input is used to trigger a beat or burst transfer on peripherals.

The event is acknowledged as soon as the event is received. When received, both the Channel Pending status bit in the Channel Status register (CHSTATUS.PEND) and the corresponding Channel n bit in the Pending Channels register (PENDCH.PENDCHn) are set. If the event is received while the channel is pending, the event trigger is lost.

The figure below shows an example where beat transfers are enabled by internal events.

**Figure 22-12. Burst Event Trigger Action**



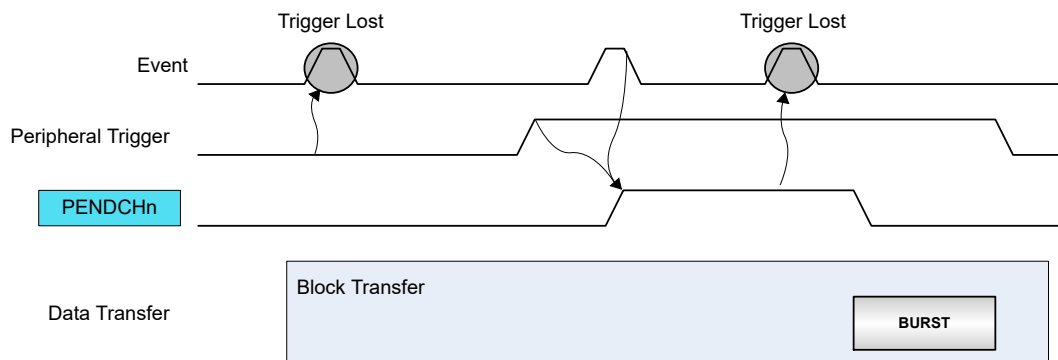
### Conditional Transfer on Strobe

The event input is used to trigger a transfer on peripherals with pending transfer requests. This event action is intended to be used with peripheral triggers, e.g., for timed communication protocols or periodic transfers between peripherals: only when the peripheral trigger coincides with the occurrence of a (possibly cyclic) event the transfer is issued.

The event is acknowledged as soon as the event is received. The peripheral trigger request is stored internally when the previous trigger action is completed (i.e., the channel is not pending) and when an active event is received. If the peripheral trigger is active, the DMA will wait for an event before the peripheral trigger is internally registered. When both event and peripheral transfer trigger are active, both CHSTATUS.PEND and PENDCH.PENDCHn are set. A software trigger will now trigger a transfer.

The figure below shows an example where the peripheral beat transfer is started by a conditional strobe event action.

**Figure 22-13. Periodic Event with Burst Peripheral Triggers**



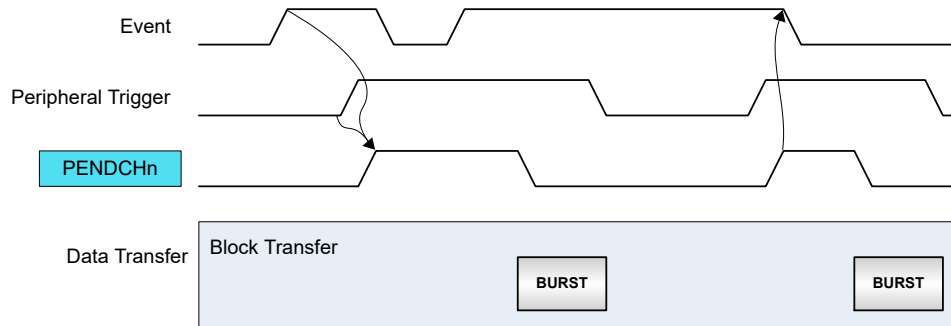
### Conditional Transfer

The event input is used to trigger a conditional transfer on peripherals with pending transfer requests. As an example, this type of event can be used for peripheral-to-peripheral transfers, where one peripheral is the source of event and the second peripheral is the source of the trigger.

Each peripheral trigger is stored internally when the event is received. When the peripheral trigger is stored internally, the Channel Pending status bit is set (CHSTATUS.PEND), the respective Pending Channel n Bit in the Pending Channels register is set (PENDCH.PENDCHn), and the event is acknowledged. A software trigger will now trigger a transfer.

The figure below shows an example where conditional event is enabled with peripheral beat trigger requests.

**Figure 22-14. Conditional Event with Burst Peripheral Triggers**



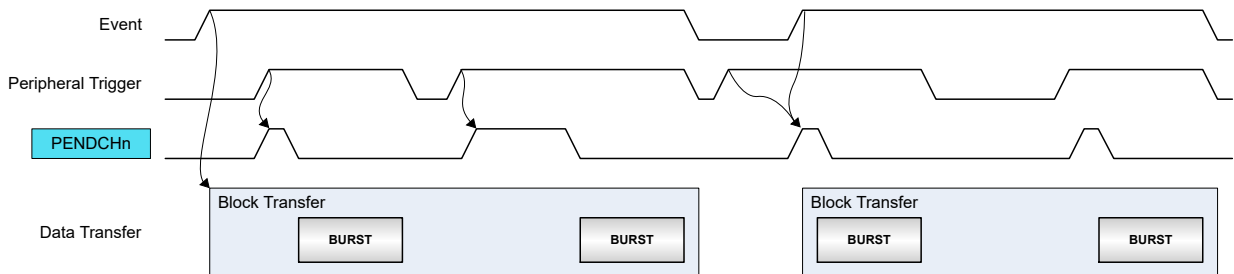
### Conditional Block Transfer

The event input is used to trigger a conditional block transfer on peripherals.

Before starting transfers within a block, an event must be received. When received, the event is acknowledged when the block transfer is completed. A software trigger will trigger a transfer.

The figure below shows an example where conditional event block transfer is started with peripheral beat trigger requests.

**Figure 22-15. Conditional Block Transfer with Burst Peripheral Triggers**



### Channel Suspend

The event input is used to suspend an ongoing channel operation. The event is acknowledged when the current AHB access is completed. For further details on Channel Suspend, refer to [22.6.3.3 Channel Suspend](#).



### Channel Resume

The event input is used to resume a suspended channel operation. The event is acknowledged as soon as the event is received and the Channel Suspend Interrupt Flag (CHINTFLAG.SUSP) is cleared. For further details refer to [22.6.3.3 Channel Suspend](#).

### Skip Next Block Suspend

This event can be used to skip the next block suspend action. If the channel is suspended before the event rises, the channel operation is resumed and the event is acknowledged. If the event rises before a suspend block action is detected, the event is kept until the next block suspend detection. When the block transfer is completed, the channel continues the operation (not suspended) and the event is acknowledged.

### Increase priority

This event can be used to increase a channel priority and to request higher quality of service (QOS), when critical transfers must be done. When the event is detected, the channel will have the highest priority and the output Quality of Service value is internally forced to the maximum value. The event is acknowledged when the trigger action execution is completed. When acknowledged, the channel will recover its initial priority level and quality of service settings.

#### 22.6.3.6 Event Output Selection

The event output selections are available only for channels supporting event outputs.

The Channel Event Output Enable can be set in the corresponding Channel n Event Control register (CHEVCTRL.EVOE). The Event Output Mode bits in Channel n Event Control register (CHEVCTRL.EVOMODE) selects the event type the channel should generate.

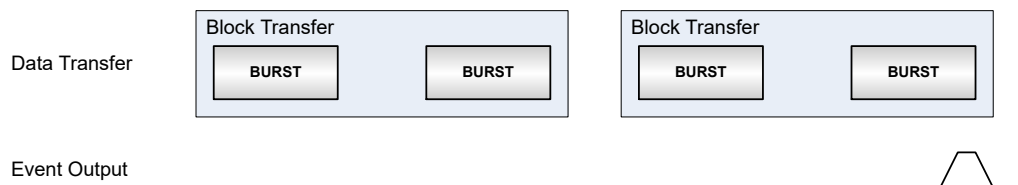
The transfer events (CHEVCTRL.EVOMODE = DEFAULT) are strobe events and their duration is one CLK\_DMACH\_AHB clock period. The transfer event type selection is available in each Descriptor Block Control location (BTCTRL.EVOSEL). Block or burst event output generation is supported.

The trigger action event (CHEVCTRL.EVOMODE = TRIGACT) is a level, active while the trigger action execution is not completed.

#### Block event output

When the block event output is selected, an event strobe is generated when the block transfer is completed. The pulse width of a block event output from a channel is one AHB clock cycle. It is also possible to use this event type to generate an event when the transaction is complete. For this type of application, the block event selection must be set in the last transfer descriptor only, as shown below.

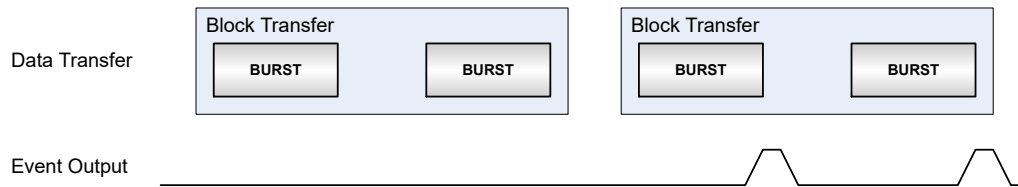
**Figure 22-16. Block Event Output Generation**



#### Burst event output

When the burst event output is selected, an event strobe is generated when each burst transfer within the corresponding block is completed. The pulse width of a burst event output from a channel is one AHB clock cycle. The figure below shows an example where the burst event output is set in the second descriptor of a linked list.

**Figure 22-17. Burst Event Output Generation**

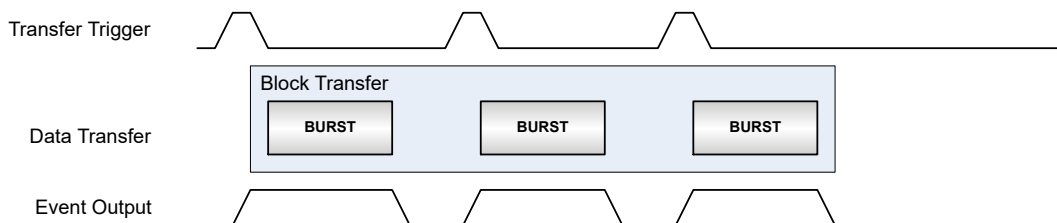


### Trigger action event output

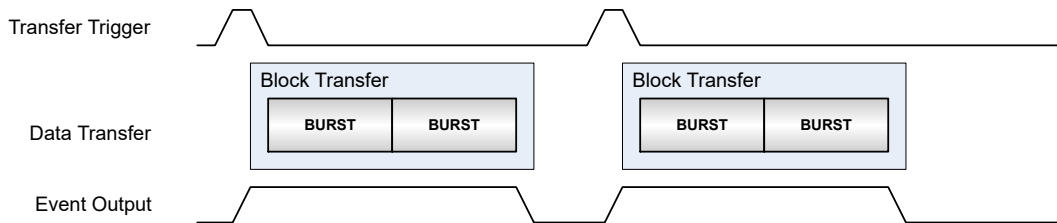
When the trigger action event output is selected, an event level is generated. Then event output is set when the transfer trigger occurred, and cleared when the corresponding trigger action is completed. The figure below shows an example for each trigger action type.

**Figure 22-18. Trigger Action Event Output Generation**

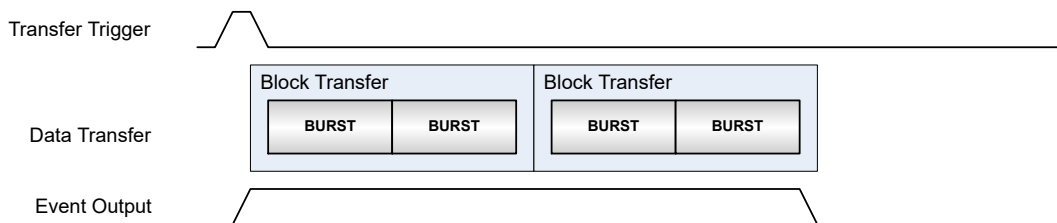
#### Burst Trigger Action Event Output



#### Block Trigger Action Event Output



#### Transaction Trigger Action Event Output



### 22.6.3.7 Aborting Transfers

Transfers on any channel can be aborted gracefully by software by disabling the corresponding DMA channel. It is also possible to abort all ongoing or pending transfers by disabling the DMAC.

When a DMA channel disable request or DMAC disable request is detected:

- Ongoing transfers of the active channel will be disabled when the ongoing beat transfer is completed and the write-back memory section is updated. This prevents transfer corruption before the channel is disabled.
- All other enabled channels will be disabled in the next clock cycle.

The corresponding Channel Enable bit in the Channel Control A register is cleared (CHCTRLA.ENABLE=0) when the channel is disabled.

The corresponding DMAC Enable bit in the Control register is cleared (CTRL.DMAENABLE=0) when the entire DMAC module is disabled.

### 22.6.3.8 CRC Operation

A Cyclic Redundancy Check (CRC) is an error detection technique used to find errors in data. It is commonly used to determine whether the data during a transmission, or data present in data and program memories has been corrupted or not. A CRC takes a data stream or a block of data as input and generates a 16- or 32-bit output that can be appended to the data and used as a checksum.

When the data is received, the device or application repeats the calculation: If the new CRC result does not match the one calculated earlier, the block contains a data error. The application will then detect this and may take a corrective action, such as requesting the data to be sent again or simply not using the incorrect data.

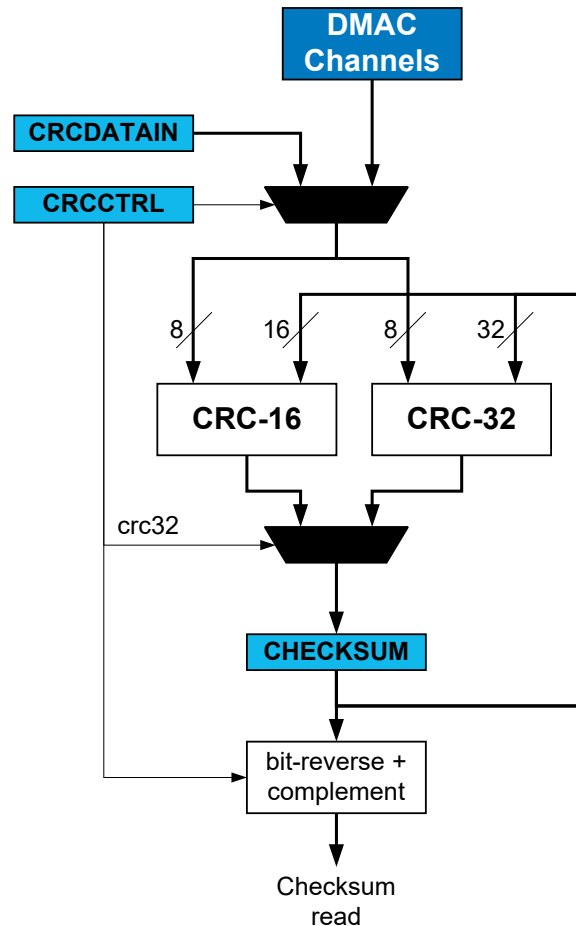
The CRC engine in DMAC supports two commonly used CRC polynomials: CRC-16 (CRC-CCITT) and CRC-32 (IEEE 802.3). Typically, applying CRC-n (CRC-16 or CRC-32) to a data block of arbitrary length will detect any single alteration that is  $\leq n$  bits in length, and will detect the fraction  $1-2^{-n}$  of all longer error bursts.

- CRC-16:
  - Polynomial:  $x^{16} + x^{12} + x^5 + 1$
  - Hex value: 0x1021
- CRC-32:
  - Polynomial:  $x^{32} + x^{26} + x^{23} + x^{22} + x^{16} + x^{12} + x^{11} + x^{10} + x^8 + x^7 + x^5 + x^4 + x^2 + x + 1$
  - Hex value: 0x04C11DB7

The data source for the CRC engine can either be one of the DMA channels or the APB bus interface, and must be selected by writing to the CRC Input Source bits in the CRC Control register (CRCCTRL.CRCSRC). The CRC engine then takes data input from the selected source and generates a checksum based on these data. The checksum is available in the CRC Checksum register (CRCCHKSUM). When CRC-32 polynomial is used, the final checksum read is bit reversed and complemented, as shown in [Figure 22-19](#).

The CRC polynomial is selected by writing to the CRC Polynomial Type bit in the CRC Control register (CRCCTRL.CRCPOLY), the default is CRC-16. The CRC engine operates on byte only. When the DMA is used as data source for the CRC engine, the DMA channel beat size setting will be used. When used with APB bus interface, the application must select the CRC Beat Size bit field of CRC Control register (CRCCTRL.CRCBEATSIZE). 8-, 16-, or 32-bit bus transfer access type is supported. The corresponding number of bytes will be written in the [CRCDATAIN](#) register and the CRC engine will operate on the input data in a byte by byte manner.

Figure 22-19. CRC Generator Block Diagram



**CRC on DMA data** CRC-16 or CRC-32 calculations can be performed on data passing through any DMA channel. Once a DMA channel is selected as the source, the CRC engine will continuously generate the CRC on the data passing through the DMA channel. The checksum is available for readout once the DMA transaction is completed or aborted. A CRC can also be generated on SRAM, Flash, or I/O memory by passing these data through a DMA channel. If the latter is done, the destination register for the DMA data can be the data input ([CRCDATAIN](#)) register in the CRC engine.

**CRC using the I/O interface** Before using the CRC engine with the I/O interface, the application must set the CRC Beat Size bits in the CRC Control register ([CRCCTRL.CRCBEATSIZE](#)). 8/16/32-bit bus transfer type can be selected.

CRC can be performed on any data by loading them into the CRC engine using the CPU and writing the data to the [CRCDATAIN](#) register. Using this method, an arbitrary number of bytes can be written to the register by the CPU, and CRC is done continuously for each byte. This means if a 32-bit data is written to the [CRCDATAIN](#) register the CRC engine takes four cycles to calculate the CRC. The CRC complete is signaled by a set [CRCBUSY](#) bit in the [CRCSTATUS](#) register. New data can be written only when [CRCBUSY](#) flag is not set.

### 22.6.3.9 Memory CRC Generation

When enabled, it is possible to automatically calculate a memory block checksum. When the channel is enabled and the descriptor is fetched, the CRC Checksum register ([CRCCHKSUM](#)) is reloaded with the

# SAM D5x/E5x Family Data Sheet

## DMAC – Direct Memory Access Controller

initial checksum value (CHKINIT) stored in the Block Transfer Destination Address register (DSTADDR). The DMA read and calculate the checksum over the data from the source address. When the checksum calculation is completed, the CRC value is stored in the CRC Checksum register (CRCCHKSUM), the Transfer Complete interrupt flag is set (CHINTFLAGn.TC MPL) and optional interrupt is generated.

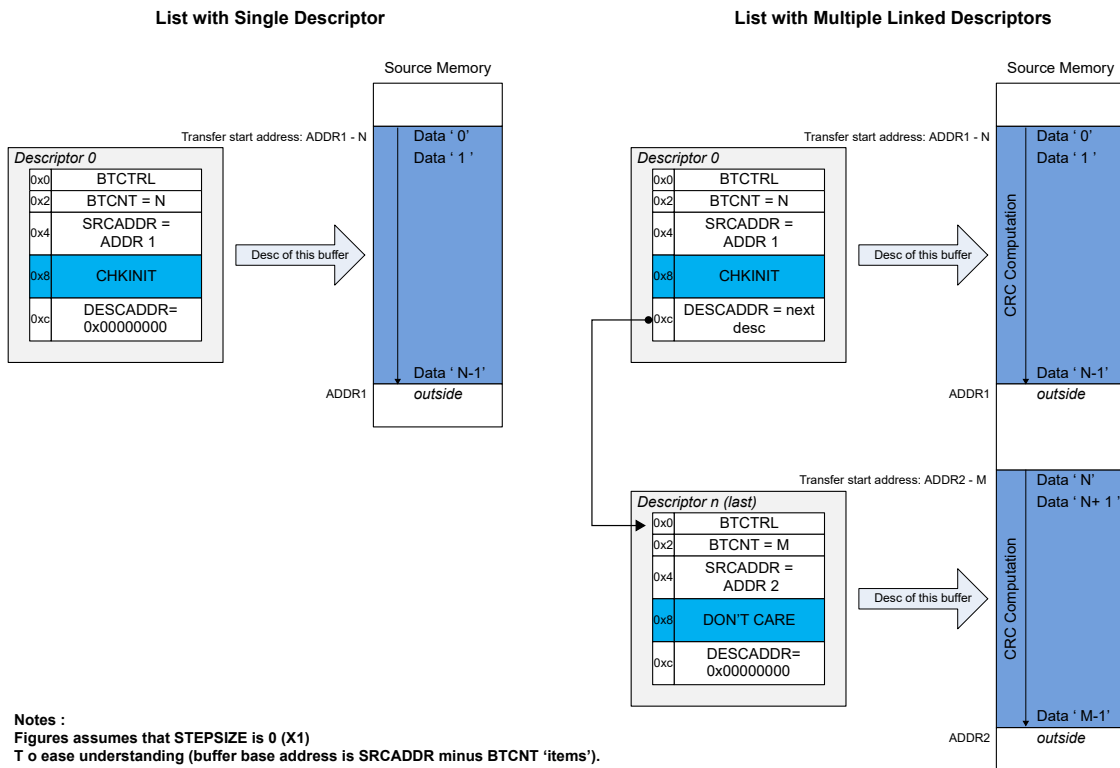
If linked descriptor is in the list (DESCADDR !=0), the DMA will fetch the next descriptor and CRC calculation continues as described above. When the last list descriptor is executed, the channel is automatically disabled.

In order to enable the memory CRC generation, the following actions must be performed:

1. The CRC module must be set to be used with a DMA channel (CRCCTRL.CRCSRC)
2. Reserve memory space addresses to configure a descriptor or a list of descriptors
3. Configure each descriptor:
  - Set the next descriptor address (DESCADDR)
  - Set the destination address with the initial checksum value (DSTADDR = CHKINIT) in the first descriptor in a list
  - Set the transfer source address (SRCADDR)
  - Set the block transfer count (BTCNT)
  - Set the memory CRC generation operation mode (CRCCTRL.CRCMODE = CR CGEN)
  - Enable optional interrupts
4. Enable the corresponding DMA channel (CHCTRLAn.ENABLE)

The figure below shows the CRC computation slots and descriptor configuration when single or linked-descriptors transfers are enabled.

**Figure 22-20. CRC Computation with Single Linked Transfers**



# SAM D5x/E5x Family Data Sheet

## DMAC – Direct Memory Access Controller

### 22.6.3.10 Memory CRC Monitor

When enabled, it is possible to continuously check a a memory block data integrity by calculating and checking the CRC checksum. The expected CRC checksum value must be located in the last memory block location, as shown in the table below:

CRCCTRL.CRCPOLY	CRCCTRL.CRCBEATSIZE	Last Memory Block Byte Locations Value (MSB Byte First)	CHECKSUM Result
CRC-16	Byte	Expected CRC[7:0]	0x00000000
	Half-word	Expected CRC[15:8]	
	Word	0x00 0x00 Expected CRC[7:0] Expected CRC[15:8]	
CRC-32	Byte	Expected CRC[31:24]	CRC Magic Number (0x2144DF1C)
	Half-word	Expected CRC[23:16]	
	Word	Expected CRC[15:8] Expected CRC[7:0]	

When the channel is enabled and the descriptor is fetched, the CRC Checksum register (CRCCHKSUM) is reloaded with the initial checksum value (CHKINIT), stored in the DSTADDR location of the first descriptor. The DMA read and calculate the checksum over the entire data from the source address. When the checksum calculation is completed the DMA read the last beat from the memory, the calculated CRC value from the CRC Checksum register is compared to zero or CRC magic number, depending on CRC polynomial selection.

If the CHECKSUM does not match the comparison value the DMA channel is disabled, and both the CRC Error bit in the Channel n Status register (CHSTATUSn.CRCERR) and Transfer Error interrupt flag (CHINTFLAGn.TERR) are set. If enabled, the Transfer Error interrupt is generated.

If the calculated checksum value matches the compare value, the Transfer Complete interrupt flag (CHINTFLAGn.TCMPL) is set, optional interrupt is generated and the DMA will perform the following actions, depending on the descriptor list settings:

- If the list has only one descriptor, the DMA will re-fetch the descriptor
- If the current descriptor is the last descriptor from the list, the DMA will fetch the first descriptor from the list

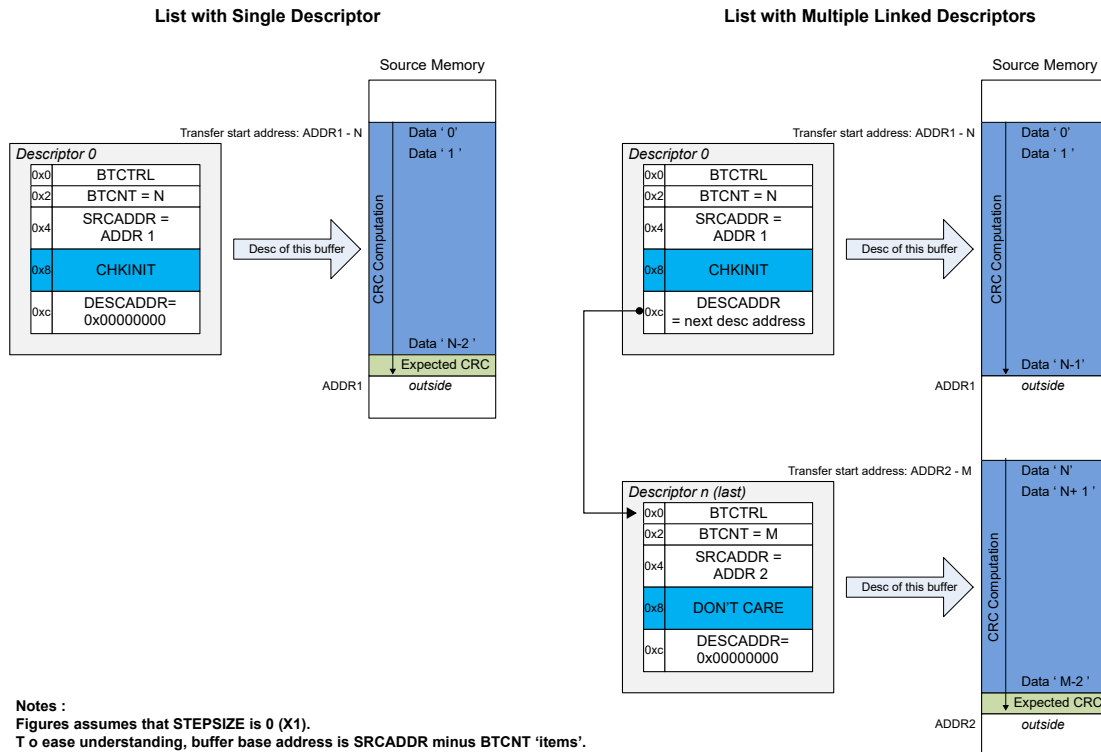
When the fetch is completed, the DMA restarts the operations described above when new triggers are detected.

In order to enable the memory CRC monitor, the following actions must be performed:

1. The CRC module must be set to be used with a DMA channel (CRCCTRL.CRCSRC)
2. Reserve memory space addresses to configure a descriptor or a list of descriptors
3. Configure each descriptor
  - Set the next descriptor address (DESCADDR)

- In the first list descriptor, set the destination address with the initial checksum value (DSTADDR = CHKINIT)
  - Set the transfer source address (SRCADDR)
  - Set the block transfer count (BTCNT)
  - Set the memory CRC monitor operation mode (CRCCTRL.CRCMODE = CRCMON)
  - Enable optional interrupts
4. Enable the corresponding DMA channel (CHCTRLAn.ENABLE)

**Figure 22-21. CRC Computation and Check with Single or Linked Transfers**



### 22.6.4 DMA Operation

Not applicable.

### 22.6.5 Interrupts

The DMAC channels have the following interrupt sources:

- Transfer Complete (TCMPL): Indicates that a block transfer is completed on the corresponding channel. Refer to [22.6.2.5 Data Transmission](#) for details.
- Transfer Error (TERR): Indicates that a bus error has occurred during a burst transfer, or that an invalid descriptor has been fetched. Refer to [22.6.2.9 Error Handling](#) for details.
- Channel Suspend (SUSP): Indicates that the corresponding channel has been suspended. Refer to [22.6.3.3 Channel Suspend](#) and [22.6.2.5 Data Transmission](#) for details.

Each interrupt source has an Interrupt flag associated with it. The Interrupt flag in the Channel Interrupt Flag Status and Clear (CHINTFLAG) register is set when the Interrupt condition occurs. Each interrupt can be individually enabled by setting the corresponding bit in the Channel Interrupt Enable Set register (CHINTENSET=1), and disabled by setting the corresponding bit in the Channel Interrupt Enable Clear register (CHINTENCLR=1).

An interrupt request is generated when the Interrupt flag is set and the corresponding interrupt is enabled. The interrupt request remains active until the Interrupt flag is cleared, the interrupt is disabled, the DMAC is reset or the corresponding DMA channel is reset. See CHINTFLAG for details on how to clear Interrupt flags. All interrupt requests are ORed together on system level to generate one combined interrupt request to the NVIC.

The user must read the Channel Interrupt Status (INTSTATUS) register to identify the channels with pending interrupts and must read the Channel Interrupt Flag Status and Clear (CHINTFLAG) register to determine which Interrupt condition is present for the corresponding channel. It is also possible to read the Interrupt Pending register (INTPEND), which provides the lowest channel number with pending interrupt and the respective Interrupt flags.

**Note:** Interrupts must be globally enabled for interrupt requests to be generated.

### 22.6.6 Events

The DMAC can generate the following output events:

- Channel (CH): Generated when a block transfer for a given channel has been completed, or when a beat transfer within a block transfer for a given channel has been completed. Refer to *Event Output Selection* for details.

Setting the Channel Event Output Enable bit (CHEVCTRLx.EVOE = 1) enables the corresponding output event configured in the Event Output Selection bit group in the Block Transfer Control register (BTCTRL.EVOSEL). Clearing CHEVCTRLx.EVOE = 0 disables the corresponding output event.

The DMAC can take the following actions on an input event:

- Transfer and Periodic Transfer Trigger (TRIG): normal transfer or periodic transfers on peripherals are enabled
- Conditional Transfer Trigger (CTRIG): conditional transfers on peripherals are enabled
- Conditional Block Transfer Trigger (CBLOCK): conditional block transfers on peripherals are enabled
- Channel Suspend Operation (SUSPEND): suspend a channel operation
- Channel Resume Operation (RESUME): resume a suspended channel operation
- Skip Next Block Suspend Action (SSKIP): skip the next block suspend transfer condition
- Increase Priority (INCPRI): increase channel priority

Setting the Channel Event Input Enable bit (CHEVCTRLx.EVIE = 1) enables the corresponding action on input event. Clearing this bit disables the corresponding action on input event. Note that several actions can be enabled for incoming events. If several events are connected to the peripheral, any enabled action will be taken for any of the incoming events. For further details on event input actions, refer to *Event Input Actions*.

**Note:** Event input and outputs are not available for every channel. Refer to the Features section for more information.

#### Related Links

[31. EVSYS – Event System](#)

[22.6.3.6 Event Output Selection](#)

[22.6.3.5 Event Input Actions](#)

### 22.6.7 Sleep Mode Operation



**22.6.8 Synchronization**  
Not applicable.

# SAM D5x/E5x Family Data Sheet

## DMAC – Direct Memory Access Controller

### 22.7 Register Summary

Offset	Name	Bit Pos.								
0x00	CTRL	7:0							DMAENABLE	SWRST
		15:8					LVLEN3	LVLEN2	LVLEN1	LVLEN0
0x02	CRCCTRL	7:0					CRCPOLY[1:0]		CRCBEATSIZE[1:0]	
		15:8	CRCMODE[1:0]			CRCSRC[5:0]				
0x04	CRCDATAIN	7:0	CRCDATAIN[7:0]							
		15:8	CRCDATAIN[15:8]							
		23:16	CRCDATAIN[23:16]							
		31:24	CRCDATAIN[31:24]							
0x08	CRCCHKSUM	7:0	CRCCHKSUM[7:0]							
		15:8	CRCCHKSUM[15:8]							
		23:16	CRCCHKSUM[23:16]							
		31:24	CRCCHKSUM[31:24]							
0x0C	CRCSTATUS	7:0						CRCERR	CRCZERO	CRCBUSY
0x0D	DBGCTRL	7:0								DBGRUN
0x0E	Reserved									
...										
0x0F										
0x10	SWTRIGCTRL	7:0	SWTRIG[7:0]							
		15:8	SWTRIG[15:8]							
		23:16	SWTRIG[23:16]							
		31:24	SWTRIG[31:24]							
0x14	PRICTRL0	7:0	RRLVLEN0	QOS00[1:0]					LVLPRIO[4:0]	
		15:8	RRLVLEN1	QOS01[1:0]					LVLPRIO[4:0]	
		23:16	RRLVLEN2	QOS02[1:0]					LVLPRIO[4:0]	
		31:24	RRLVLEN3	QOS03[1:0]					LVLPRIO[4:0]	
0x18	Reserved									
...										
0x1F										
0x20	INTPEND	7:0					ID[4:0]			
		15:8	PEND	BUSY	FERR	CRCERR		SUSP	TCMPL	TERR
0x22	Reserved									
...										
0x23										
0x24	INTSTATUS	7:0	CHINT[7:0]							
		15:8	CHINT[15:8]							
		23:16	CHINT[23:16]							
		31:24	CHINT[31:24]							
0x28	BUSYCH	7:0	BUSYCH[7:0]							
		15:8	BUSYCH[15:8]							
		23:16	BUSYCH[23:16]							
		31:24	BUSYCH[31:24]							

# SAM D5x/E5x Family Data Sheet

## DMAC – Direct Memory Access Controller

.....continued

Offset	Name	Bit Pos.									
0x2C	PENDCH	7:0	PENDCH7	PENDCH6	PENDCH5	PENDCH4	PENDCH3	PENDCH2	PENDCH1	PENDCH0	
		15:8	PENDCH15	PENDCH14	PENDCH13	PENDCH12	PENDCH11	PENDCH10	PENDCH9	PENDCH8	
		23:16	PENDCH23	PENDCH22	PENDCH21	PENDCH20	PENDCH19	PENDCH18	PENDCH17	PENDCH16	
		31:24	PENDCH31	PENDCH30	PENDCH29	PENDCH28	PENDCH27	PENDCH26	PENDCH25	PENDCH24	
0x30	ACTIVE	7:0					LVLEX3	LVLEX2	LVLEX1	LVLEX0	
		15:8	ABUSY				ID[4:0]				
		23:16	BTCNT[7:0]								
		31:24	BTCNT[15:8]								
0x34	BASEADDR	7:0	BASEADDR[7:0]								
		15:8	BASEADDR[15:8]								
		23:16	BASEADDR[23:16]								
		31:24	BASEADDR[31:24]								
0x38	WRBADDR	7:0	WRBADDR[7:0]								
		15:8	WRBADDR[15:8]								
		23:16	WRBADDR[23:16]								
		31:24	WRBADDR[31:24]								
0x3C ... 0x3F	Reserved										
0x40	CHCTRLA0	7:0		RUNSTDBY					ENABLE	SWRST	
		15:8	TRIGSRC[7:0]								
		23:16			TRIGACT[1:0]						
		31:24			THRESHOLD[1:0]	BURSTLEN[3:0]					
0x44	CHCTRLB0	7:0						CMD[1:0]			
0x45	CHPRILVL0	7:0						PRILVL[1:0]			
0x46	CHEVCTRL0	7:0	EVOE	EVIE	EVOMODE[1:0]			EVACT[2:0]			
0x47 ... 0x4B	Reserved										
0x4C	CHINTENCLR0	7:0					SUSP	TCMPL	TERR		
0x4D	CHINTENSET0	7:0					SUSP	TCMPL	TERR		
0x4E	CHINTFLAG0	7:0					SUSP	TCMPL	TERR		
0x4F	CHSTATUS0	7:0					CRCERR	FERR	BUSY	PEND	
0x50	CHCTRLA1	7:0		RUNSTDBY					ENABLE	SWRST	
		15:8	TRIGSRC[7:0]								
		23:16			TRIGACT[1:0]						
		31:24			THRESHOLD[1:0]	BURSTLEN[3:0]					
0x54	CHCTRLB1	7:0						CMD[1:0]			
0x55	CHPRILVL1	7:0						PRILVL[1:0]			
0x56	CHEVCTRL1	7:0	EVOE	EVIE	EVOMODE[1:0]			EVACT[2:0]			
0x57 ... 0x5B	Reserved										
0x5C	CHINTENCLR1	7:0					SUSP	TCMPL	TERR		
0x5D	CHINTENSET1	7:0					SUSP	TCMPL	TERR		

# SAM D5x/E5x Family Data Sheet

## DMAC – Direct Memory Access Controller

.....continued										
Offset	Name	Bit Pos.								
0x5E	CHINTFLAG1	7:0						SUSP	TCMPL	TERR
0x5F	CHSTATUS1	7:0					CRCERR	FERR	BUSY	PEND
0x60	CHCTRLA2	7:0		RUNSTDBY					ENABLE	SWRST
		15:8	TRIGSRC[7:0]							
		23:16			TRIGACT[1:0]					
		31:24			THRESHOLD[1:0]		BURSTLEN[3:0]			
0x64	CHCTRLB2	7:0						CMD[1:0]		
0x65	CHPRILVL2	7:0						PRILVL[1:0]		
0x66	CHEVCTRL2	7:0	EVOE	EVIE	EVOMODE[1:0]			EVACTION[2:0]		
0x67 ... 0x6B	Reserved									
0x6C	CHINTENCLR2	7:0						SUSP	TCMPL	TERR
0x6D	CHINTENSET2	7:0						SUSP	TCMPL	TERR
0x6E	CHINTFLAG2	7:0						SUSP	TCMPL	TERR
0x6F	CHSTATUS2	7:0					CRCERR	FERR	BUSY	PEND
0x70	CHCTRLA3	7:0		RUNSTDBY					ENABLE	SWRST
		15:8	TRIGSRC[7:0]							
		23:16			TRIGACT[1:0]					
		31:24			THRESHOLD[1:0]		BURSTLEN[3:0]			
0x74	CHCTRLB3	7:0						CMD[1:0]		
0x75	CHPRILVL3	7:0						PRILVL[1:0]		
0x76	CHEVCTRL3	7:0	EVOE	EVIE	EVOMODE[1:0]			EVACTION[2:0]		
0x77 ... 0x7B	Reserved									
0x7C	CHINTENCLR3	7:0						SUSP	TCMPL	TERR
0x7D	CHINTENSET3	7:0						SUSP	TCMPL	TERR
0x7E	CHINTFLAG3	7:0						SUSP	TCMPL	TERR
0x7F	CHSTATUS3	7:0					CRCERR	FERR	BUSY	PEND
0x80	CHCTRLA4	7:0		RUNSTDBY					ENABLE	SWRST
		15:8	TRIGSRC[7:0]							
		23:16			TRIGACT[1:0]					
		31:24			THRESHOLD[1:0]		BURSTLEN[3:0]			
0x84	CHCTRLB4	7:0						CMD[1:0]		
0x85	CHPRILVL4	7:0						PRILVL[1:0]		
0x86	CHEVCTRL4	7:0	EVOE	EVIE	EVOMODE[1:0]			EVACTION[2:0]		
0x87 ... 0x8B	Reserved									
0x8C	CHINTENCLR4	7:0						SUSP	TCMPL	TERR
0x8D	CHINTENSET4	7:0						SUSP	TCMPL	TERR
0x8E	CHINTFLAG4	7:0						SUSP	TCMPL	TERR
0x8F	CHSTATUS4	7:0					CRCERR	FERR	BUSY	PEND

# SAM D5x/E5x Family Data Sheet

## DMAC – Direct Memory Access Controller

.....continued

Offset	Name	Bit Pos.								
0x90	CHCTRLA5	7:0		RUNSTDBY					ENABLE	SWRST
		15:8	TRIGSRC[7:0]							
		23:16			TRIGACT[1:0]					
		31:24			THRESHOLD[1:0]	BURSTLEN[3:0]				
0x94	CHCTRLB5	7:0							CMD[1:0]	
0x95	CHPRILVL5	7:0							PRILVL[1:0]	
0x96	CHEVCTRL5	7:0	EVOE	EVIE	EVOMODE[1:0]				EVACTION[2:0]	
0x97 ... 0x9B	Reserved									
0x9C	CHINTENCLR5	7:0						SUSP	TCMPL	TERR
0x9D	CHINTENSET5	7:0						SUSP	TCMPL	TERR
0x9E	CHINTFLAG5	7:0						SUSP	TCMPL	TERR
0x9F	CHSTATUS5	7:0					CRCERR	FERR	BUSY	PEND
0xA0	CHCTRLA6	7:0		RUNSTDBY					ENABLE	SWRST
		15:8	TRIGSRC[7:0]							
		23:16			TRIGACT[1:0]					
		31:24			THRESHOLD[1:0]	BURSTLEN[3:0]				
0xA4	CHCTRLB6	7:0							CMD[1:0]	
0xA5	CHPRILVL6	7:0							PRILVL[1:0]	
0xA6	CHEVCTRL6	7:0	EVOE	EVIE	EVOMODE[1:0]				EVACTION[2:0]	
0xA7 ... 0xAB	Reserved									
0xAC	CHINTENCLR6	7:0						SUSP	TCMPL	TERR
0xAD	CHINTENSET6	7:0						SUSP	TCMPL	TERR
0xAE	CHINTFLAG6	7:0						SUSP	TCMPL	TERR
0xAF	CHSTATUS6	7:0					CRCERR	FERR	BUSY	PEND
0xB0	CHCTRLA7	7:0		RUNSTDBY					ENABLE	SWRST
		15:8	TRIGSRC[7:0]							
		23:16			TRIGACT[1:0]					
		31:24			THRESHOLD[1:0]	BURSTLEN[3:0]				
0xB4	CHCTRLB7	7:0							CMD[1:0]	
0xB5	CHPRILVL7	7:0							PRILVL[1:0]	
0xB6	CHEVCTRL7	7:0	EVOE	EVIE	EVOMODE[1:0]				EVACTION[2:0]	
0xB7 ... 0xBB	Reserved									
0xBC	CHINTENCLR7	7:0						SUSP	TCMPL	TERR
0xBD	CHINTENSET7	7:0						SUSP	TCMPL	TERR
0xBE	CHINTFLAG7	7:0						SUSP	TCMPL	TERR
0xBF	CHSTATUS7	7:0					CRCERR	FERR	BUSY	PEND

# SAM D5x/E5x Family Data Sheet

## DMAC – Direct Memory Access Controller

.....continued

Offset	Name	Bit Pos.								
0xC0	CHCTRLA8	7:0		RUNSTDBY					ENABLE	SWRST
		15:8	TRIGSRC[7:0]							
		23:16			TRIGACT[1:0]					
		31:24			THRESHOLD[1:0]	BURSTLEN[3:0]				
0xC4	CHCTRLB8	7:0							CMD[1:0]	
0xC5	CHPRILVL8	7:0							PRILVL[1:0]	
0xC6	CHEVCTRL8	7:0	EVOE	EVIE	EVOMODE[1:0]				EVACT[2:0]	
0xC7	Reserved									
0xCB										
0xCC	CHINTENCLR8	7:0					SUSP	TCMPL	TERR	
0xCD	CHINTENSET8	7:0					SUSP	TCMPL	TERR	
0xCE	CHINTFLAG8	7:0					SUSP	TCMPL	TERR	
0xCF	CHSTATUS8	7:0					CRCERR	FERR	BUSY	PEND
0xD0	CHCTRLA9	7:0		RUNSTDBY					ENABLE	SWRST
		15:8	TRIGSRC[7:0]							
		23:16			TRIGACT[1:0]					
		31:24			THRESHOLD[1:0]	BURSTLEN[3:0]				
0xD4	CHCTRLB9	7:0							CMD[1:0]	
0xD5	CHPRILVL9	7:0							PRILVL[1:0]	
0xD6	CHEVCTRL9	7:0	EVOE	EVIE	EVOMODE[1:0]				EVACT[2:0]	
0xD7	Reserved									
0xDB										
0xDC	CHINTENCLR9	7:0					SUSP	TCMPL	TERR	
0xDD	CHINTENSET9	7:0					SUSP	TCMPL	TERR	
0xDE	CHINTFLAG9	7:0					SUSP	TCMPL	TERR	
0xDF	CHSTATUS9	7:0					CRCERR	FERR	BUSY	PEND
0xE0	CHCTRLA10	7:0		RUNSTDBY					ENABLE	SWRST
		15:8	TRIGSRC[7:0]							
		23:16			TRIGACT[1:0]					
		31:24			THRESHOLD[1:0]	BURSTLEN[3:0]				
0xE4	CHCTRLB10	7:0							CMD[1:0]	
0xE5	CHPRILVL10	7:0							PRILVL[1:0]	
0xE6	CHEVCTRL10	7:0	EVOE	EVIE	EVOMODE[1:0]				EVACT[2:0]	
0xE7	Reserved									
0xEB										
0xEC	CHINTENCLR10	7:0					SUSP	TCMPL	TERR	
0xED	CHINTENSET10	7:0					SUSP	TCMPL	TERR	
0xEE	CHINTFLAG10	7:0					SUSP	TCMPL	TERR	
0xEF	CHSTATUS10	7:0					CRCERR	FERR	BUSY	PEND

# SAM D5x/E5x Family Data Sheet

## DMAC – Direct Memory Access Controller

.....continued										
Offset	Name	Bit Pos.								
0xF0	CHCTRLA11	7:0		RUNSTDBY				ENABLE	SWRST	
		15:8	TRIGSRC[7:0]							
		23:16			TRIGACT[1:0]					
		31:24			THRESHOLD[1:0]	BURSTLEN[3:0]				
0xF4	CHCTRLB11	7:0						CMD[1:0]		
0xF5	CHPRILVL11	7:0						PRILVL[1:0]		
0xF6	CHEVCTRL11	7:0	EVOE	EVIE	EVOMODE[1:0]			EVACT[2:0]		
0xF7 ... 0xFB	Reserved									
0xFC	CHINTENCLR11	7:0					SUSP	TCMPL	TERR	
0xFD	CHINTENSET11	7:0					SUSP	TCMPL	TERR	
0xFE	CHINTFLAG11	7:0					SUSP	TCMPL	TERR	
0xFF	CHSTATUS11	7:0					CRCERR	FERR	BUSY	PEND
0x0100	CHCTRLA12	7:0		RUNSTDBY				ENABLE	SWRST	
		15:8	TRIGSRC[7:0]							
		23:16			TRIGACT[1:0]					
		31:24			THRESHOLD[1:0]	BURSTLEN[3:0]				
0x0104	CHCTRLB12	7:0						CMD[1:0]		
0x0105	CHPRILVL12	7:0						PRILVL[1:0]		
0x0106	CHEVCTRL12	7:0	EVOE	EVIE	EVOMODE[1:0]			EVACT[2:0]		
0x0107 ... 0x010B	Reserved									
0x010C	CHINTENCLR12	7:0					SUSP	TCMPL	TERR	
0x010D	CHINTENSET12	7:0					SUSP	TCMPL	TERR	
0x010E	CHINTFLAG12	7:0					SUSP	TCMPL	TERR	
0x010F	CHSTATUS12	7:0					CRCERR	FERR	BUSY	PEND
0x0110	CHCTRLA13	7:0		RUNSTDBY				ENABLE	SWRST	
		15:8	TRIGSRC[7:0]							
		23:16			TRIGACT[1:0]					
		31:24			THRESHOLD[1:0]	BURSTLEN[3:0]				
0x0114	CHCTRLB13	7:0						CMD[1:0]		
0x0115	CHPRILVL13	7:0						PRILVL[1:0]		
0x0116	CHEVCTRL13	7:0	EVOE	EVIE	EVOMODE[1:0]			EVACT[2:0]		
0x0117 ... 0x011B	Reserved									
0x011C	CHINTENCLR13	7:0					SUSP	TCMPL	TERR	
0x011D	CHINTENSET13	7:0					SUSP	TCMPL	TERR	
0x011E	CHINTFLAG13	7:0					SUSP	TCMPL	TERR	
0x011F	CHSTATUS13	7:0					CRCERR	FERR	BUSY	PEND

# SAM D5x/E5x Family Data Sheet

## DMAC – Direct Memory Access Controller

.....continued										
Offset	Name	Bit Pos.								
0x0120	CHCTRLA14	7:0		RUNSTDBY				ENABLE	SWRST	
		15:8	TRIGSRC[7:0]							
		23:16			TRIGACT[1:0]					
		31:24			THRESHOLD[1:0]	BURSTLEN[3:0]				
0x0124	CHCTRLB14	7:0						CMD[1:0]		
0x0125	CHPRILVL14	7:0						PRILVL[1:0]		
0x0126	CHEVCTRL14	7:0	EVOE	EVIE	EVOMODE[1:0]			EVACT[2:0]		
0x0127 ... 0x012B	Reserved									
0x012C	CHINTENCLR14	7:0					SUSP	TCMPL	TERR	
0x012D	CHINTENSET14	7:0					SUSP	TCMPL	TERR	
0x012E	CHINTFLAG14	7:0					SUSP	TCMPL	TERR	
0x012F	CHSTATUS14	7:0				CRCERR	FERR	BUSY	PEND	
0x0130	CHCTRLA15	7:0		RUNSTDBY				ENABLE	SWRST	
		15:8	TRIGSRC[7:0]							
		23:16			TRIGACT[1:0]					
		31:24			THRESHOLD[1:0]	BURSTLEN[3:0]				
0x0134	CHCTRLB15	7:0						CMD[1:0]		
0x0135	CHPRILVL15	7:0						PRILVL[1:0]		
0x0136	CHEVCTRL15	7:0	EVOE	EVIE	EVOMODE[1:0]			EVACT[2:0]		
0x0137 ... 0x013B	Reserved									
0x013C	CHINTENCLR15	7:0					SUSP	TCMPL	TERR	
0x013D	CHINTENSET15	7:0					SUSP	TCMPL	TERR	
0x013E	CHINTFLAG15	7:0					SUSP	TCMPL	TERR	
0x013F	CHSTATUS15	7:0				CRCERR	FERR	BUSY	PEND	
0x0140	CHCTRLA16	7:0		RUNSTDBY				ENABLE	SWRST	
		15:8	TRIGSRC[7:0]							
		23:16			TRIGACT[1:0]					
		31:24			THRESHOLD[1:0]	BURSTLEN[3:0]				
0x0144	CHCTRLB16	7:0						CMD[1:0]		
0x0145	CHPRILVL16	7:0						PRILVL[1:0]		
0x0146	CHEVCTRL16	7:0	EVOE	EVIE	EVOMODE[1:0]			EVACT[2:0]		
0x0147 ... 0x014B	Reserved									
0x014C	CHINTENCLR16	7:0					SUSP	TCMPL	TERR	
0x014D	CHINTENSET16	7:0					SUSP	TCMPL	TERR	
0x014E	CHINTFLAG16	7:0					SUSP	TCMPL	TERR	
0x014F	CHSTATUS16	7:0				CRCERR	FERR	BUSY	PEND	



# SAM D5x/E5x Family Data Sheet

## DMAC – Direct Memory Access Controller

.....continued

Offset	Name	Bit Pos.								
0x0150	CHCTRLA17	7:0		RUNSTDBY					ENABLE	SWRST
		15:8	TRIGSRC[7:0]							
		23:16			TRIGACT[1:0]					
		31:24			THRESHOLD[1:0]	BURSTLEN[3:0]				
0x0154	CHCTRLB17	7:0							CMD[1:0]	
0x0155	CHPRILVL17	7:0							PRILVL[1:0]	
0x0156	CHEVCTRL17	7:0	EVOE	EVIE	EVOMODE[1:0]				EVACTION[2:0]	
0x0157	Reserved									
0x015B										
0x015C	CHINTENCLR17	7:0						SUSP	TCMPL	TERR
0x015D	CHINTENSET17	7:0						SUSP	TCMPL	TERR
0x015E	CHINTFLAG17	7:0						SUSP	TCMPL	TERR
0x015F	CHSTATUS17	7:0					CRCERR	FERR	BUSY	PEND
0x0160	CHCTRLA18	7:0		RUNSTDBY					ENABLE	SWRST
		15:8	TRIGSRC[7:0]							
		23:16			TRIGACT[1:0]					
		31:24			THRESHOLD[1:0]	BURSTLEN[3:0]				
0x0164	CHCTRLB18	7:0							CMD[1:0]	
0x0165	CHPRILVL18	7:0							PRILVL[1:0]	
0x0166	CHEVCTRL18	7:0	EVOE	EVIE	EVOMODE[1:0]				EVACTION[2:0]	
0x0167	Reserved									
0x016B										
0x016C	CHINTENCLR18	7:0						SUSP	TCMPL	TERR
0x016D	CHINTENSET18	7:0						SUSP	TCMPL	TERR
0x016E	CHINTFLAG18	7:0						SUSP	TCMPL	TERR
0x016F	CHSTATUS18	7:0					CRCERR	FERR	BUSY	PEND
0x0170	CHCTRLA19	7:0		RUNSTDBY					ENABLE	SWRST
		15:8	TRIGSRC[7:0]							
		23:16			TRIGACT[1:0]					
		31:24			THRESHOLD[1:0]	BURSTLEN[3:0]				
0x0174	CHCTRLB19	7:0							CMD[1:0]	
0x0175	CHPRILVL19	7:0							PRILVL[1:0]	
0x0176	CHEVCTRL19	7:0	EVOE	EVIE	EVOMODE[1:0]				EVACTION[2:0]	
0x0177	Reserved									
0x017B										
0x017C	CHINTENCLR19	7:0						SUSP	TCMPL	TERR
0x017D	CHINTENSET19	7:0						SUSP	TCMPL	TERR
0x017E	CHINTFLAG19	7:0						SUSP	TCMPL	TERR
0x017F	CHSTATUS19	7:0					CRCERR	FERR	BUSY	PEND

# SAM D5x/E5x Family Data Sheet

## DMAC – Direct Memory Access Controller

.....continued

Offset	Name	Bit Pos.								
0x0180	CHCTRLA20	7:0		RUNSTDBY					ENABLE	SWRST
		15:8	TRIGSRC[7:0]							
		23:16			TRIGACT[1:0]					
		31:24			THRESHOLD[1:0]	BURSTLEN[3:0]				
0x0184	CHCTRLB20	7:0							CMD[1:0]	
0x0185	CHPRILVL20	7:0							PRILVL[1:0]	
0x0186	CHEVCTRL20	7:0	EVOE	EVIE	EVOMODE[1:0]				EVACTION[2:0]	
0x0187	Reserved									
0x018B										
0x018C	CHINTENCLR20	7:0						SUSP	TCMPL	TERR
0x018D	CHINTENSET20	7:0						SUSP	TCMPL	TERR
0x018E	CHINTFLAG20	7:0						SUSP	TCMPL	TERR
0x018F	CHSTATUS20	7:0					CRCERR	FERR	BUSY	PEND
0x0190	CHCTRLA21	7:0		RUNSTDBY					ENABLE	SWRST
		15:8	TRIGSRC[7:0]							
		23:16			TRIGACT[1:0]					
		31:24			THRESHOLD[1:0]	BURSTLEN[3:0]				
0x0194	CHCTRLB21	7:0							CMD[1:0]	
0x0195	CHPRILVL21	7:0							PRILVL[1:0]	
0x0196	CHEVCTRL21	7:0	EVOE	EVIE	EVOMODE[1:0]				EVACTION[2:0]	
0x0197	Reserved									
0x019B										
0x019C	CHINTENCLR21	7:0						SUSP	TCMPL	TERR
0x019D	CHINTENSET21	7:0						SUSP	TCMPL	TERR
0x019E	CHINTFLAG21	7:0						SUSP	TCMPL	TERR
0x019F	CHSTATUS21	7:0					CRCERR	FERR	BUSY	PEND
0x01A0	CHCTRLA22	7:0		RUNSTDBY					ENABLE	SWRST
		15:8	TRIGSRC[7:0]							
		23:16			TRIGACT[1:0]					
		31:24			THRESHOLD[1:0]	BURSTLEN[3:0]				
0x01A4	CHCTRLB22	7:0							CMD[1:0]	
0x01A5	CHPRILVL22	7:0							PRILVL[1:0]	
0x01A6	CHEVCTRL22	7:0	EVOE	EVIE	EVOMODE[1:0]				EVACTION[2:0]	
0x01A7	Reserved									
0x01AB										
0x01AC	CHINTENCLR22	7:0						SUSP	TCMPL	TERR
0x01AD	CHINTENSET22	7:0						SUSP	TCMPL	TERR
0x01AE	CHINTFLAG22	7:0						SUSP	TCMPL	TERR
0x01AF	CHSTATUS22	7:0					CRCERR	FERR	BUSY	PEND

# SAM D5x/E5x Family Data Sheet

## DMAC – Direct Memory Access Controller

.....continued

Offset	Name	Bit Pos.								
0x01B0	CHCTRLA23	7:0		RUNSTDBY					ENABLE	SWRST
		15:8	TRIGSRC[7:0]							
		23:16			TRIGACT[1:0]					
		31:24			THRESHOLD[1:0]	BURSTLEN[3:0]				
0x01B4	CHCTRLB23	7:0							CMD[1:0]	
0x01B5	CHPRILVL23	7:0							PRILVL[1:0]	
0x01B6	CHEVCTRL23	7:0	EVOE	EVIE	EVOMODE[1:0]				EVACTION[2:0]	
0x01B7	Reserved									
0x01BB										
0x01BC	CHINTENCLR23	7:0						SUSP	TCMPL	TERR
0x01BD	CHINTENSET23	7:0						SUSP	TCMPL	TERR
0x01BE	CHINTFLAG23	7:0						SUSP	TCMPL	TERR
0x01BF	CHSTATUS23	7:0					CRCERR	FERR	BUSY	PEND
0x01C0	CHCTRLA24	7:0		RUNSTDBY					ENABLE	SWRST
		15:8	TRIGSRC[7:0]							
		23:16			TRIGACT[1:0]					
		31:24			THRESHOLD[1:0]	BURSTLEN[3:0]				
0x01C4	CHCTRLB24	7:0							CMD[1:0]	
0x01C5	CHPRILVL24	7:0							PRILVL[1:0]	
0x01C6	CHEVCTRL24	7:0	EVOE	EVIE	EVOMODE[1:0]				EVACTION[2:0]	
0x01C7	Reserved									
0x01CB										
0x01CC	CHINTENCLR24	7:0						SUSP	TCMPL	TERR
0x01CD	CHINTENSET24	7:0						SUSP	TCMPL	TERR
0x01CE	CHINTFLAG24	7:0						SUSP	TCMPL	TERR
0x01CF	CHSTATUS24	7:0					CRCERR	FERR	BUSY	PEND
0x01D0	CHCTRLA25	7:0		RUNSTDBY					ENABLE	SWRST
		15:8	TRIGSRC[7:0]							
		23:16			TRIGACT[1:0]					
		31:24			THRESHOLD[1:0]	BURSTLEN[3:0]				
0x01D4	CHCTRLB25	7:0							CMD[1:0]	
0x01D5	CHPRILVL25	7:0							PRILVL[1:0]	
0x01D6	CHEVCTRL25	7:0	EVOE	EVIE	EVOMODE[1:0]				EVACTION[2:0]	
0x01D7	Reserved									
0x01DB										
0x01DC	CHINTENCLR25	7:0						SUSP	TCMPL	TERR
0x01DD	CHINTENSET25	7:0						SUSP	TCMPL	TERR
0x01DE	CHINTFLAG25	7:0						SUSP	TCMPL	TERR
0x01DF	CHSTATUS25	7:0					CRCERR	FERR	BUSY	PEND

# SAM D5x/E5x Family Data Sheet

## DMAC – Direct Memory Access Controller

.....continued

Offset	Name	Bit Pos.								
0x01E0	CHCTRLA26	7:0		RUNSTDBY					ENABLE	SWRST
		15:8	TRIGSRC[7:0]							
		23:16			TRIGACT[1:0]					
		31:24			THRESHOLD[1:0]	BURSTLEN[3:0]				
0x01E4	CHCTRLB26	7:0							CMD[1:0]	
0x01E5	CHPRILVL26	7:0							PRILVL[1:0]	
0x01E6	CHEVCTRL26	7:0	EVOE	EVIE	EVOMODE[1:0]				EVACTION[2:0]	
0x01E7	...									
0x01EB	Reserved									
0x01EC	CHINTENCLR26	7:0						SUSP	TCMPL	TERR
0x01ED	CHINTENSET26	7:0						SUSP	TCMPL	TERR
0x01EE	CHINTFLAG26	7:0						SUSP	TCMPL	TERR
0x01EF	CHSTATUS26	7:0					CRCERR	FERR	BUSY	PEND
0x01F0	CHCTRLA27	7:0		RUNSTDBY					ENABLE	SWRST
		15:8	TRIGSRC[7:0]							
		23:16			TRIGACT[1:0]					
		31:24			THRESHOLD[1:0]	BURSTLEN[3:0]				
0x01F4	CHCTRLB27	7:0							CMD[1:0]	
0x01F5	CHPRILVL27	7:0							PRILVL[1:0]	
0x01F6	CHEVCTRL27	7:0	EVOE	EVIE	EVOMODE[1:0]				EVACTION[2:0]	
0x01F7	...									
0x01FB	Reserved									
0x01FC	CHINTENCLR27	7:0						SUSP	TCMPL	TERR
0x01FD	CHINTENSET27	7:0						SUSP	TCMPL	TERR
0x01FE	CHINTFLAG27	7:0						SUSP	TCMPL	TERR
0x01FF	CHSTATUS27	7:0					CRCERR	FERR	BUSY	PEND
0x0200	CHCTRLA28	7:0		RUNSTDBY					ENABLE	SWRST
		15:8	TRIGSRC[7:0]							
		23:16			TRIGACT[1:0]					
		31:24			THRESHOLD[1:0]	BURSTLEN[3:0]				
0x0204	CHCTRLB28	7:0							CMD[1:0]	
0x0205	CHPRILVL28	7:0							PRILVL[1:0]	
0x0206	CHEVCTRL28	7:0	EVOE	EVIE	EVOMODE[1:0]				EVACTION[2:0]	
0x0207	...									
0x020B	Reserved									
0x020C	CHINTENCLR28	7:0						SUSP	TCMPL	TERR
0x020D	CHINTENSET28	7:0						SUSP	TCMPL	TERR
0x020E	CHINTFLAG28	7:0						SUSP	TCMPL	TERR
0x020F	CHSTATUS28	7:0					CRCERR	FERR	BUSY	PEND

# SAM D5x/E5x Family Data Sheet

## DMAC – Direct Memory Access Controller

.....continued

Offset	Name	Bit Pos.								
0x0210	CHCTRLA29	7:0		RUNSTDBY					ENABLE	SWRST
		15:8	TRIGSRC[7:0]							
		23:16			TRIGACT[1:0]					
		31:24			THRESHOLD[1:0]	BURSTLEN[3:0]				
0x0214	CHCTRLB29	7:0							CMD[1:0]	
0x0215	CHPRILVL29	7:0							PRILVL[1:0]	
0x0216	CHEVCTRL29	7:0	EVOE	EVIE	EVOMODE[1:0]				EVACTION[2:0]	
0x0217	...									
0x021B	Reserved									
0x021C	CHINTENCLR29	7:0						SUSP	TCMPL	TERR
0x021D	CHINTENSET29	7:0						SUSP	TCMPL	TERR
0x021E	CHINTFLAG29	7:0						SUSP	TCMPL	TERR
0x021F	CHSTATUS29	7:0					CRCERR	FERR	BUSY	PEND
0x0220	CHCTRLA30	7:0		RUNSTDBY					ENABLE	SWRST
		15:8	TRIGSRC[7:0]							
		23:16			TRIGACT[1:0]					
		31:24			THRESHOLD[1:0]	BURSTLEN[3:0]				
0x0224	CHCTRLB30	7:0							CMD[1:0]	
0x0225	CHPRILVL30	7:0							PRILVL[1:0]	
0x0226	CHEVCTRL30	7:0	EVOE	EVIE	EVOMODE[1:0]				EVACTION[2:0]	
0x0227	...									
0x022B	Reserved									
0x022C	CHINTENCLR30	7:0						SUSP	TCMPL	TERR
0x022D	CHINTENSET30	7:0						SUSP	TCMPL	TERR
0x022E	CHINTFLAG30	7:0						SUSP	TCMPL	TERR
0x022F	CHSTATUS30	7:0					CRCERR	FERR	BUSY	PEND
0x0230	CHCTRLA31	7:0		RUNSTDBY					ENABLE	SWRST
		15:8	TRIGSRC[7:0]							
		23:16			TRIGACT[1:0]					
		31:24			THRESHOLD[1:0]	BURSTLEN[3:0]				
0x0234	CHCTRLB31	7:0							CMD[1:0]	
0x0235	CHPRILVL31	7:0							PRILVL[1:0]	
0x0236	CHEVCTRL31	7:0	EVOE	EVIE	EVOMODE[1:0]				EVACTION[2:0]	
0x0237	...									
0x023B	Reserved									
0x023C	CHINTENCLR31	7:0						SUSP	TCMPL	TERR
0x023D	CHINTENSET31	7:0						SUSP	TCMPL	TERR
0x023E	CHINTFLAG31	7:0						SUSP	TCMPL	TERR
0x023F	CHSTATUS31	7:0					CRCERR	FERR	BUSY	PEND

### 22.8 Register Description

Registers can be 8, 16, or 32 bits wide. Atomic 8-, 16- and 32-bit accesses are supported. In addition, the 8-bit quarters and 16-bit halves of a 32-bit register, and the 8-bit halves of a 16-bit register can be accessed directly.

Some registers are optionally write-protected by the Peripheral Access Controller (PAC). Optional PAC write protection is denoted by the "PAC Write-Protection" property in each individual register description. For details, refer to [22.5.8 Register Access Protection](#).

Some registers are enable-protected, meaning they can only be written when the peripheral is disabled. Enable-protection is denoted by the "Enable-Protected" property in each individual register description.

# SAM D5x/E5x Family Data Sheet

## DMAC – Direct Memory Access Controller

### 22.8.1 Control

**Name:** CTRL  
**Offset:** 0x00  
**Reset:** 0x0000  
**Property:** PAC Write-Protection, Enable-Protected

	Bit	15	14	13	12	11	10	9	8
						LVLEN3	LVLEN2	LVLEN1	LVLEN0
Access						R/W	R/W	R/W	R/W
Reset						0	0	0	0
	Bit	7	6	5	4	3	2	1	0
								DMAENABLE	SWRST
Access								R/W	R/W
Reset								0	0

**Bits 8, 9, 10, 11 – LVLENx** Priority Level x Enable

When this bit is set, all requests with the corresponding level will be fed into the arbiter block. When cleared, all requests with the corresponding level will be ignored.

For details on arbitration schemes, refer to the [Arbitration](#) section.

These bits are not enable-protected.

Value	Description
0	Transfer requests for Priority level x will not be handled.
1	Transfer requests for Priority level x will be handled.

**Bit 1 – DMAENABLE** DMA Enable

Setting this bit will enable the DMA module.

Writing a '0' to this bit will disable the DMA module. When writing a '0' during an ongoing transfer, the bit will not be cleared until the internal data transfer buffer is empty and the DMA transfer is aborted. The internal data transfer buffer will be empty once the ongoing burst transfer is completed.

This bit is not enable-protected.

Value	Description
0	The peripheral is disabled.
1	The peripheral is enabled.

**Bit 0 – SWRST** Software Reset

Writing a '0' to this bit has no effect.

Writing a '1' to this bit when both the DMAC and the CRC module are disabled (DMAENABLE and CRCENABLE are '0') resets all registers in the DMAC (except DBGCTRL) to their initial state. If either the DMAC or CRC module is enabled, the Reset request will be ignored and the DMAC will return an access error.

Value	Description
0	There is no Reset operation ongoing.
1	A Reset operation is ongoing.

# SAM D5x/E5x Family Data Sheet

## DMAC – Direct Memory Access Controller

### 22.8.2 CRC Control

**Name:** CRCCTRL  
**Offset:** 0x02  
**Reset:** 0x0000  
**Property:** PAC Write-Protection, Enable-Protected

	Bit	15	14	13	12	11	10	9	8
		CRCMODE[1:0]			CRCSRC[5:0]				
Access		R/W	R/W	R/W	R/W	R/W	R/W	R/W	R/W
Reset		0	0	0	0	0	0	0	0
	Bit	7	6	5	4	3	2	1	0
						CRCPOLY[1:0]		CRCBEATSIZE[1:0]	
Access						R/W	R/W	R/W	R/W
Reset						0	0	0	0

#### Bits 15:14 – CRCMODE[1:0] CRC Operating Mode

These bits define the block transfer mode.

Value	Name	Description
0x0	DEFAULT	Default operating mode
0x1		Reserved
0x2	CRCMON	Memory CRC monitor operating mode
0x3	CRCGEN	Memory CRC generation operating mode

#### Bits 13:8 – CRCSRC[5:0] CRC Input Source

These bits select the input source for generating the CRC. The selected source is locked until either the CRC generation is completed or the CRC module is disabled. This means the CRCSRC cannot be modified when the CRC operation is ongoing. The lock is signaled by the CRCBUSY status bit. CRC generation complete is generated and signaled from the selected source when used with the DMA channel.

Value	Name	Description
0x00	NOACT	No action
0x01	IO	I/O interface
0x02 – 0x1F		Reserved
0x20	CH0	DMA channel 0
0x21	CH1	DMA channel 1
0x22	CH2	DMA channel 2
0x23	CH3	DMA channel 3
0x24	CH4	DMA channel 4
0x25	CH5	DMA channel 5
0x26	CH6	DMA channel 6
0x27	CH7	DMA channel 7
0x28	CH8	DMA channel 8
0x29	CH9	DMA channel 9
0x2A	CH10	DMA channel 10
0x2B	CH11	DMA channel 11



# SAM D5x/E5x Family Data Sheet

## DMAC – Direct Memory Access Controller

Value	Name	Description
0x2C	CH12	DMA channel 12
0x2D	CH13	DMA channel 13
0x2E	CH14	DMA channel 14
0x2F	CH15	DMA channel 15
0x30	CH16	DMA channel 16
0x31	CH17	DMA channel 17
0x32	CH18	DMA channel 18
0x33	CH19	DMA channel 19
0x34	CH20	DMA channel 20
0x35	CH21	DMA channel 21
0x36	CH22	DMA channel 22
0x37	CH23	DMA channel 23
0x38	CH24	DMA channel 24
0x39	CH25	DMA channel 25
0x3A	CH26	DMA channel 26
0x3B	CH27	DMA channel 27
0x3C	CH28	DMA channel 28
0x3D	CH29	DMA channel 29
0x3E	CH30	DMA channel 30
0x3F	CH31	DMA channel 31

### Bits 3:2 – CRCPOLY[1:0] CRC Polynomial Type

These bits select the CRC polynomial type.

Value	Name	Description
0x0	CRC16	CRC-16 (CRC-CCITT)
0x1	CRC32	CRC32 (IEEE 802.3)
0x2–0x3		Reserved

### Bits 1:0 – CRCBEATSIZE[1:0] CRC Beat Size

These bits define the size of the data transfer for each bus access when the CRC is used with I/O interface.

Value	Name	Description
0x0	BYTE	8-bit bus transfer
0x1	WORD	16-bit bus transfer
0x2	WORD	32-bit bus transfer
0x3		Reserved

# SAM D5x/E5x Family Data Sheet

## DMAC – Direct Memory Access Controller

### 22.8.3 CRC Data Input

**Name:** CRCDATAIN  
**Offset:** 0x04  
**Reset:** 0x00000000  
**Property:** PAC Write Protection

	Bit	31	30	29	28	27	26	25	24
		CRCDATAIN[31:24]							
Access		R/W	R/W	R/W	R/W	R/W	R/W	R/W	R/W
Reset		0	0	0	0	0	0	0	0
	Bit	23	22	21	20	19	18	17	16
		CRCDATAIN[23:16]							
Access		R/W	R/W	R/W	R/W	R/W	R/W	R/W	R/W
Reset		0	0	0	0	0	0	0	0
	Bit	15	14	13	12	11	10	9	8
		CRCDATAIN[15:8]							
Access		R/W	R/W	R/W	R/W	R/W	R/W	R/W	R/W
Reset		0	0	0	0	0	0	0	0
	Bit	7	6	5	4	3	2	1	0
		CRCDATAIN[7:0]							
Access		R/W	R/W	R/W	R/W	R/W	R/W	R/W	R/W
Reset		0	0	0	0	0	0	0	0

**Bits 31:0 – CRCDATAIN[31:0] CRC Data Input**

These bits store the data for which the CRC checksum is computed. A new CRC checksum is ready (CRCBEAT+ 1) clock cycles after the CRCDATAIN register is written.

# SAM D5x/E5x Family Data Sheet

## DMAC – Direct Memory Access Controller

### 22.8.4 CRC Checksum

**Name:** CRCCHKSUM  
**Offset:** 0x08  
**Reset:** 0x00000000  
**Property:** PAC Write Protection, Enable-Protected

The CRCCHKSUM represents the 16- or 32-bit checksum value and the generated CRC. The register is reset to zero by default, but it is possible to reset all bits to one by writing the CRCCHKSUM register directly. It is possible to write this register only when the CRC module is disabled. If CRC-32 is selected and the CRC Status Busy flag is cleared (i.e., CRC generation is completed or aborted), the bit reversed (bit 31 is swapped with bit 0, bit 30 with bit 1, etc.) and complemented result will be read from CRCCHKSUM. If CRC-16 is selected or the CRC Status Busy flag is set (i.e., CRC generation is ongoing), CRCCHKSUM will contain the actual content.

	Bit	31	30	29	28	27	26	25	24
		CRCCHKSUM[31:24]							
Access		R/W	R/W	R/W	R/W	R/W	R/W	R/W	R/W
Reset		0	0	0	0	0	0	0	0
	Bit	23	22	21	20	19	18	17	16
		CRCCHKSUM[23:16]							
Access		R/W	R/W	R/W	R/W	R/W	R/W	R/W	R/W
Reset		0	0	0	0	0	0	0	0
	Bit	15	14	13	12	11	10	9	8
		CRCCHKSUM[15:8]							
Access		R/W	R/W	R/W	R/W	R/W	R/W	R/W	R/W
Reset		0	0	0	0	0	0	0	0
	Bit	7	6	5	4	3	2	1	0
		CRCCHKSUM[7:0]							
Access		R/W	R/W	R/W	R/W	R/W	R/W	R/W	R/W
Reset		0	0	0	0	0	0	0	0

**Bits 31:0 – CRCCHKSUM[31:0] CRC Checksum**

These bits store the generated CRC result. The 16 MSB bits are always read zero when CRC-16 is enabled.

# SAM D5x/E5x Family Data Sheet

## DMAC – Direct Memory Access Controller

### 22.8.5 CRC Status

**Name:** CRCSTATUS  
**Offset:** 0x0C  
**Reset:** 0x00  
**Property:** PAC Write-Protection

	7	6	5	4	3	2	1	0
Bit						CRCERR	CRCZERO	CRCBUSY
Access						R	R	R/W
Reset						0	0	0

**Bit 2 – CRCERR** CRC Error

This bit is read '1' when the memory CRC monitor detects data corruption.

**Bit 1 – CRCZERO** CRC Zero

This bit is cleared when a new CRC source is selected.

This bit is set when the CRC generation is complete and the CRC Checksum is zero.

**Bit 0 – CRCBUSY** CRC Module Busy

When used with an I/O interface ([CRCCTRL.CRCSRC=0x1](#)):

- This bit is cleared by writing a '1' to it
- This bit is set when the CRC Data Input (CRCDATAIN) register is written
- Writing a '1' to this bit will clear the CRC Module Busy bit
- Writing a '0' to this bit has no effect

When used with a DMA channel ([CRCCTRL.CRCSRC=0x20...0x3F](#)):

- This bit is cleared when the corresponding DMA channel is disabled
- This bit is set when the corresponding DMA channel is enabled
- Writing a '1' to this bit has no effect
- Writing a '0' to this bit has no effect

# SAM D5x/E5x Family Data Sheet

## DMAC – Direct Memory Access Controller

### 22.8.6 Debug Control

**Name:** DBGCTRL  
**Offset:** 0x0D  
**Reset:** 0x00  
**Property:** PAC Write Protection

Bit	7	6	5	4	3	2	1	0
								DBGRUN
Access								R/W
Reset								0

#### Bit 0 – DBGRUN Debug Run

This bit is not reset by a Software Reset.

This bit controls the functionality when the CPU is halted by an external debugger.

Value	Description
0	The DMAC is halted when the CPU is halted by an external debugger.
1	The DMAC continues normal operation when the CPU is halted by an external debugger.

# SAM D5x/E5x Family Data Sheet

## DMAC – Direct Memory Access Controller

### 22.8.7 Software Trigger Control

**Name:** SWTRIGCTRL  
**Offset:** 0x10  
**Reset:** 0x00000000  
**Property:** PAC Write-Protection

	Bit	31	30	29	28	27	26	25	24
		SWTRIG[31:24]							
Access		R/W	R/W	R/W	R/W	R/W	R/W	R/W	R/W
Reset		0	0	0	0	0	0	0	0
	Bit	23	22	21	20	19	18	17	16
		SWTRIG[23:16]							
Access		R/W	R/W	R/W	R/W	R/W	R/W	R/W	R/W
Reset		0	0	0	0	0	0	0	0
	Bit	15	14	13	12	11	10	9	8
		SWTRIG[15:8]							
Access		R/W	R/W	R/W	R/W	R/W	R/W	R/W	R/W
Reset		0	0	0	0	0	0	0	0
	Bit	7	6	5	4	3	2	1	0
		SWTRIG[7:0]							
Access		R/W	R/W	R/W	R/W	R/W	R/W	R/W	R/W
Reset		0	0	0	0	0	0	0	0

**Bits 31:0 – SWTRIG[31:0]** Channel n Software Trigger [n = 31..0]

This bit is cleared when the Channel Pending bit in the Channel Status register ([CHSTATUS.PEND](#)) for the corresponding channel is either set, or by writing a '1' to it.

This bit is set if [CHSTATUS.PEND](#) is already '1' when writing a '1' to that bit.

Writing a '0' to this bit will clear the bit.

Writing a '1' to this bit will generate a DMA software trigger on channel x, if [CHSTATUS.PEND](#)=0 for channel x. [CHSTATUS.PEND](#) will be set and SWTRIGn will remain cleared.

# SAM D5x/E5x Family Data Sheet

## DMAC – Direct Memory Access Controller

### 22.8.8 Priority Control 0

**Name:** PRICTRL0  
**Offset:** 0x14  
**Reset:** 0x40404040  
**Property:** PAC Write-Protection

	Bit	31	30	29	28	27	26	25	24
		RRLVLEN3		QOS03[1:0]		LVLPRI3[4:0]			
Access		R/W	R/W	R/W	R/W	R/W	R/W	R/W	R/W
Reset		0	1	0	0	0	0	0	0
	Bit	23	22	21	20	19	18	17	16
		RRLVLEN2		QOS02[1:0]		LVLPRI2[4:0]			
Access		R/W	R/W	R/W	R/W	R/W	R/W	R/W	R/W
Reset		0	1	0	0	0	0	0	0
	Bit	15	14	13	12	11	10	9	8
		RRLVLEN1		QOS01[1:0]		LVLPRI1[4:0]			
Access		R/W	R/W	R/W	R/W	R/W	R/W	R/W	R/W
Reset		0	1	0	0	0	0	0	0
	Bit	7	6	5	4	3	2	1	0
		RRLVLEN0		QOS00[1:0]		LVLPRI0[4:0]			
Access		R/W	R/W	R/W	R/W	R/W	R/W	R/W	R/W
Reset		0	1	0	0	0	0	0	0

**Bits 7, 15, 23, 31 – RRLVLEN** Level Round-Robin Scheduling Enable

For details on arbitration schemes, refer to [22.6.2.4 Arbitration](#).

Value	Description
0	Static arbitration scheme for channels with level 0 priority.
1	Round-robin arbitration scheme for channels with level 0 priority.

**Bits 5:6, 13:14, 21:22, 29:30 – QOS** Level Quality of Service QoS Name Description  
 0x0 DISABLE Background (no sensitive operation)  
 0x1 LOW Sensitive to bandwidth  
 0x2 MEDIUM Sensitive to latency  
 0x3 Critical Latency Critical Latency

**Bits 0:4, 8:12, 16:20, 24:28 – LVLPRI** Level Channel Priority Number

When round-robin arbitration is enabled (PRICTRL0.RRLVLEN0=1) for priority level 0, this register holds the channel number of the last DMA channel being granted access as the active channel with priority level 0.

When static arbitration is enabled (PRICTRL0.RRLVLEN0=0) for priority level 0, and the value of this bit group is non-zero, it will not affect the static priority scheme.

This bit group is not reset when round-robin arbitration gets disabled (PRICTRL0.RRLVLEN0 written to '0').

# SAM D5x/E5x Family Data Sheet

## DMAC – Direct Memory Access Controller

### 22.8.9 Interrupt Pending

**Name:** INTPEND  
**Offset:** 0x20  
**Reset:** 0x0000  
**Property:** -

This register allows the user to identify the lowest DMA channel with pending interrupt. An interrupt that handles several channels should consult the INTPEND register to find out which channel number has priority (ignoring/filtering each channel that has its own interrupt line). An interrupt dedicated to only one channel must not use the INTPEND register.

Bit	15	14	13	12	11	10	9	8
	PEND	BUSY	FERR	CRCERR		SUSP	TCMPL	TERR
Access	R	R	R	R/W		R/W	R/W	R/W
Reset	0	0	0	0		0	0	0
Bit	7	6	5	4	3	2	1	0
				ID[4:0]				
Access				R/W	R/W	R/W	R/W	R/W
Reset				0	0	0	0	0

**Bit 15 – PEND** Pending

This bit will read '1' when the channel selected by Channel ID field (ID) is pending.

**Bit 14 – BUSY** Busy

This bit will read '1' when the channel selected by Channel ID field (ID) is busy.

**Bit 13 – FERR** Fetch Error

This bit will read '1' when the channel selected by Channel ID field (ID) fetched an invalid descriptor.

**Bit 12 – CRCERR** CRC Error

This bit will read '1' when the channel selected by Channel ID field (ID) has a CRC Error Status Flag bit set, and is set when the CRC monitor detects data corruption.

Writing a '0' to this bit has no effect.

Writing a '1' to this bit will clear it. It will also clear the corresponding flag in the Channel n Interrupt Flag Status and Clear register (CHINTFLAGn), where n is determined by the Channel ID bit field (ID).

**Bit 10 – SUSP** Channel Suspend

This bit will read '1' when the channel selected by Channel ID field (ID) has pending Suspend interrupt.

Writing a '0' to this bit has no effect.

Writing a '1' to this bit will clear it. It will also clear the corresponding flag in the Channel n Interrupt Flag Status and Clear register (CHINTFLAGn), where n is determined by the Channel ID bit field (ID).

**Bit 9 – TCMPL** Transfer Complete

This bit will read '1' when the channel selected by Channel ID field (ID) has pending Transfer Complete interrupt.

Writing a '0' to this bit has no effect.

Writing a '1' to this bit will clear it. It will also clear the corresponding flag in the Channel n Interrupt Flag Status and Clear register (CHINTFLAGn), where n is determined by the Channel ID bit field (ID).



# SAM D5x/E5x Family Data Sheet

## DMAC – Direct Memory Access Controller

---

### **Bit 8 – TERR** Transfer Error

This bit will read '1' when the channel selected by Channel ID field (ID) has pending Transfer Error interrupt.

Writing a '0' to this bit has no effect.

Writing a '1' to this bit will clear it. It will also clear the corresponding flag in the Channel n Interrupt Flag Status and Clear register (CHINTFLAGn), where n is determined by the Channel ID bit field (ID).

### **Bits 4:0 – ID[4:0]** Channel ID

These bits store the lowest channel number with pending interrupts. The number is valid if Suspend (SUSP), Transfer Complete (TCMPL) or Transfer Error (TERR) bits are set. The Channel ID field is refreshed when a new channel (with channel number less than the current one) with pending interrupts is detected, or when the application clears the corresponding channel interrupt sources. When no pending channels interrupts are available, these bits will always return zero value when read.

When the bits are written, indirect access to the corresponding Channel Interrupt Flag register is enabled.

# SAM D5x/E5x Family Data Sheet

## DMAC – Direct Memory Access Controller

### 22.8.10 Interrupt Status

**Name:** INTSTATUS  
**Offset:** 0x24  
**Reset:** 0x00000000  
**Property:** -

	31	30	29	28	27	26	25	24
	CHINT[31:24]							
Access	R	R	R	R	R	R	R	R
Reset	0	0	0	0	0	0	0	0
	23	22	21	20	19	18	17	16
	CHINT[23:16]							
Access	R	R	R	R	R	R	R	R
Reset	0	0	0	0	0	0	0	0
	15	14	13	12	11	10	9	8
	CHINT[15:8]							
Access	R	R	R	R	R	R	R	R
Reset	0	0	0	0	0	0	0	0
	7	6	5	4	3	2	1	0
	CHINT[7:0]							
Access	R	R	R	R	R	R	R	R
Reset	0	0	0	0	0	0	0	0

**Bits 31:0 – CHINT[31:0]** Channel n Pending Interrupt [n=31..0]

This bit is set when Channel n has a pending interrupt/the interrupt request is received.

This bit is cleared when the corresponding Channel n interrupts are disabled or the interrupts sources are cleared.

# SAM D5x/E5x Family Data Sheet

## DMAC – Direct Memory Access Controller

### 22.8.11 Busy Channels

**Name:** BUSYCH  
**Offset:** 0x28  
**Reset:** 0x00000000  
**Property:** -

Bit	31	30	29	28	27	26	25	24
BUSYCH[31:24]								
Access	R	R	R	R	R	R	R	R
Reset	0	0	0	0	0	0	0	0
Bit	23	22	21	20	19	18	17	16
BUSYCH[23:16]								
Access	R	R	R	R	R	R	R	R
Reset	0	0	0	0	0	0	0	0
Bit	15	14	13	12	11	10	9	8
BUSYCH[15:8]								
Access	R	R	R	R	R	R	R	R
Reset	0	0	0	0	0	0	0	0
Bit	7	6	5	4	3	2	1	0
BUSYCH[7:0]								
Access	R	R	R	R	R	R	R	R
Reset	0	0	0	0	0	0	0	0

**Bits 31:0 – BUSYCH[31:0]** Busy Channel n [x=31..0]

This bit is cleared when the channel trigger action for DMA channel n is complete, when a bus error for DMA channel n is detected, or when DMA channel n is disabled.

This bit is set when DMA channel n starts a DMA transfer.

# SAM D5x/E5x Family Data Sheet

## DMAC – Direct Memory Access Controller

### 22.8.12 Pending Channels

**Name:** PENDING  
**Offset:** 0x2C  
**Reset:** 0x00000000  
**Property:** -

Bit	31	30	29	28	27	26	25	24
	PENDCH31	PENDCH30	PENDCH29	PENDCH28	PENDCH27	PENDCH26	PENDCH25	PENDCH24
Access	R	R	R	R	R	R	R	R
Reset	0	0	0	0	0	0	0	0
Bit	23	22	21	20	19	18	17	16
	PENDCH23	PENDCH22	PENDCH21	PENDCH20	PENDCH19	PENDCH18	PENDCH17	PENDCH16
Access	R	R	R	R	R	R	R	R
Reset	0	0	0	0	0	0	0	0
Bit	15	14	13	12	11	10	9	8
	PENDCH15	PENDCH14	PENDCH13	PENDCH12	PENDCH11	PENDCH10	PENDCH9	PENDCH8
Access	R	R	R	R	R	R	R	R
Reset	0	0	0	0	0	0	0	0
Bit	7	6	5	4	3	2	1	0
	PENDCH7	PENDCH6	PENDCH5	PENDCH4	PENDCH3	PENDCH2	PENDCH1	PENDCH0
Access	R	R	R	R	R	R	R	R
Reset	0	0	0	0	0	0	0	0

**Bits 0, 1, 2, 3, 4, 5, 6, 7, 8, 9, 10, 11, 12, 13, 14, 15, 16, 17, 18, 19, 20, 21, 22, 23, 24, 25, 26, 27, 28, 29, 30, 31 – PENDCH** Pending Channel n [n=31..0]

This bit is cleared when trigger execution defined by channel trigger action settings for DMA channel n is started, when a bus error for DMA channel n is detected or when DMA channel n is disabled. For details on trigger action settings, refer to CHCTRLB.TRIGACT.

This bit is set when a transfer is pending on DMA channel n.

# SAM D5x/E5x Family Data Sheet

## DMAC – Direct Memory Access Controller

### 22.8.13 Active Channel and Levels

**Name:** ACTIVE  
**Offset:** 0x30  
**Reset:** 0x00000000  
**Property:** -

	Bit	31	30	29	28	27	26	25	24
		BTCNT[15:8]							
Access		R	R	R	R	R	R	R	R
Reset		0	0	0	0	0	0	0	0
	Bit	23	22	21	20	19	18	17	16
		BTCNT[7:0]							
Access		R	R	R	R	R	R	R	R
Reset		0	0	0	0	0	0	0	0
	Bit	15	14	13	12	11	10	9	8
		ABUSY			ID[4:0]				
Access		R			R	R	R	R	R
Reset		0			0	0	0	0	0
	Bit	7	6	5	4	3	2	1	0
						LVLEX3	LVLEX2	LVLEX1	LVLEX0
Access						R	R	R	R
Reset						0	0	0	0

**Bits 31:16 – BTCNT[15:0]** Active Channel Block Transfer Count

These bits hold the 16-bit block transfer count of the ongoing transfer. This value is stored in the active channel and written back in the corresponding Write-Back channel memory location when the arbiter grants a new channel access. The value is valid only when the active channel Active Busy flag (ABUSY) is set.

**Bit 15 – ABUSY** Active Channel Busy

This bit is cleared when the active transfer count is written back in the write-back memory section. This bit is set when the next descriptor transfer count is read from the write-back memory section.

**Bits 12:8 – ID[4:0]** Active Channel ID

These bits hold the channel index currently stored in the active channel registers. The value is updated each time the arbiter grants a new channel transfer access request.

**Bits 0, 1, 2, 3 – LVLEXx** Level x Channel Trigger Request Executing [x=3..0]

This bit is set when a level-x channel trigger request is executing or pending. This bit is cleared when no request is pending or being executed.

# SAM D5x/E5x Family Data Sheet

## DMAC – Direct Memory Access Controller

### 22.8.14 Descriptor Memory Section Base Address

**Name:** BASEADDR  
**Offset:** 0x34  
**Reset:** 0x00000000  
**Property:** PAC Write Protection, Enable-Protected

	Bit	31	30	29	28	27	26	25	24
		BASEADDR[31:24]							
Access		R/W	R/W	R/W	R/W	R/W	R/W	R/W	R/W
Reset		0	0	0	0	0	0	0	0
	Bit	23	22	21	20	19	18	17	16
		BASEADDR[23:16]							
Access		R/W	R/W	R/W	R/W	R/W	R/W	R/W	R/W
Reset		0	0	0	0	0	0	0	0
	Bit	15	14	13	12	11	10	9	8
		BASEADDR[15:8]							
Access		R/W	R/W	R/W	R/W	R/W	R/W	R/W	R/W
Reset		0	0	0	0	0	0	0	0
	Bit	7	6	5	4	3	2	1	0
		BASEADDR[7:0]							
Access		R/W	R/W	R/W	R/W	R/W	R/W	R/W	R/W
Reset		0	0	0	0	0	0	0	0

**Bits 31:0 – BASEADDR[31:0] Descriptor Memory Base Address**

These bits store the Descriptor memory section base address. The value must be 128-bit aligned.

# SAM D5x/E5x Family Data Sheet

## DMAC – Direct Memory Access Controller

### 22.8.15 Write-Back Memory Section Base Address

**Name:** WRBADDR  
**Offset:** 0x38  
**Reset:** 0x00000000  
**Property:** PAC Write Protection, Enable-Protected

	Bit	31	30	29	28	27	26	25	24
		WRBADDR[31:24]							
Access		R/W	R/W	R/W	R/W	R/W	R/W	R/W	R/W
Reset		0	0	0	0	0	0	0	0
	Bit	23	22	21	20	19	18	17	16
		WRBADDR[23:16]							
Access		R/W	R/W	R/W	R/W	R/W	R/W	R/W	R/W
Reset		0	0	0	0	0	0	0	0
	Bit	15	14	13	12	11	10	9	8
		WRBADDR[15:8]							
Access		R/W	R/W	R/W	R/W	R/W	R/W	R/W	R/W
Reset		0	0	0	0	0	0	0	0
	Bit	7	6	5	4	3	2	1	0
		WRBADDR[7:0]							
Access		R/W	R/W	R/W	R/W	R/W	R/W	R/W	R/W
Reset		0	0	0	0	0	0	0	0

**Bits 31:0 – WRBADDR[31:0] Write-Back Memory Base Address**

These bits store the Write-Back memory base address. The value must be 128-bit aligned.

# SAM D5x/E5x Family Data Sheet

## DMAC – Direct Memory Access Controller

### 22.8.16 Channel Control A

**Name:** CHCTRLA  
**Offset:** 0x40 + n\*0x10 [n=0..31]  
**Reset:** 0x00000000  
**Property:** PAC Write-Protection, Enable-Protected

	Bit	31	30	29	28	27	26	25	24
				THRESHOLD[1:0]		BURSTLEN[3:0]			
Access				R/W	R/W	R/W	R/W	R/W	R/W
Reset				0	0	0	0	0	0
	Bit	23	22	21	20	19	18	17	16
				TRIGACT[1:0]					
Access				R/W	R/W				
Reset				0	0				
	Bit	15	14	13	12	11	10	9	8
		TRIGSRC[7:0]							
Access		R/W	R/W	R/W	R/W	R/W	R/W	R/W	R/W
Reset		0	0	0	0	0	0	0	0
	Bit	7	6	5	4	3	2	1	0
			RUNSTDBY					ENABLE	SWRST
Access			R/W					R/W	R/W
Reset			0					0	0

#### Bits 29:28 – THRESHOLD[1:0] FIFO Threshold

These bits define the threshold from which the DMA starts to write to the destination. These bits have no effect in the case of single beat transfers.

These bits are not enable-protected.

Value	Name	Description
0x0	1BEAT	Destination write starts after each beat source address read
0x1	2BEATS	Destination write starts after 2-beats source address read
0x2	4BEATS	Destination write starts after 4-beats source address read
0x3	8BEATS	Destination write starts after 8-beats source address read

#### Bits 27:24 – BURSTLEN[3:0] Burst Length

These bits define the burst mode.

These bits are not enable-protected.

Value	Name	Description
0x0	SINGLE	Single-beat burst
0x1	2BEAT	2-beats burst length
0x2	3BEAT	3-beats burst length
0x3	4BEAT	4-beats burst length
0x4	5BEAT	5-beats burst length
0x5	6BEAT	6-beats burst length
0x6	7BEAT	7-beats burst length



# SAM D5x/E5x Family Data Sheet

## DMAC – Direct Memory Access Controller

Value	Name	Description
0x7	8BEAT	8-beats burst length
0x8	9BEAT	9-beats burst length
0x9	10BEAT	10-beats burst length
0xA	11BEAT	11-beats burst length
0xB	12BEAT	12-beats burst length
0xC	13BEAT	13-beats burst length
0xD	14BEAT	14-beats burst length
0xE	15BEAT	15-beats burst length
0xF	16BEAT	16-beats burst length

### Bits 21:20 – TRIGACT[1:0] Trigger Action

These bits define the trigger action used for a transfer.

These bits are not enable-protected.

Value	Name	Description
0x0	BLOCK	One trigger required for each block transfer
0x1		Reserved
0x2	BURST	One trigger required for each burst transfer
0x3	TRANSACTION	One trigger required for each transaction

### Bits 15:8 – TRIGSRC[7:0] Trigger Source

These bits define the peripheral that will be the source of a trigger.

Index	Instance	Channel	Presentation
0x00	DISABLE		Only software/event triggers
0x01	RTC	TIMESTAMP	DMA RTC timestamp trigger
0x02	DSU	DCC0	DMAC ID for DCC0 register
0x03	DSU	DCC1	DMAC ID for DCC1 register
0x04	SERCOM0	RX	Index of DMA RX trigger
0x05	SERCOM0	TX	Index of DMA TX trigger
0x06	SERCOM1	RX	Index of DMA RX trigger
0x07	SERCOM1	TX	Index of DMA TX trigger
0x08	SERCOM2	RX	Index of DMA RX trigger
0x09	SERCOM2	TX	Index of DMA TX trigger
0x0A	SERCOM3	RX	Index of DMA RX trigger
0x0B	SERCOM3	TX	Index of DMA TX trigger
0x0C	SERCOM4	RX	Index of DMA RX trigger
0x0D	SERCOM4	TX	Index of DMA TX trigger
0x0E	SERCOM5	RX	Index of DMA RX trigger
0x0F	SERCOM5	TX	Index of DMA TX trigger
0x10	SERCOM6	RX	Index of DMA RX trigger

# SAM D5x/E5x Family Data Sheet

## DMAC – Direct Memory Access Controller

.....continued

Index	Instance	Channel	Presentation
0x11	SERCOM6	TX	Index of DMA TX trigger
0x12	SERCOM7	RX	Index of DMA RX trigger
0x13	SERCOM7	TX	Index of DMA TX trigger
0x14	CAN0	DEBUG	DMA CAN Debug Req
0x15	CAN1	DEBUG	DMA CAN Debug Req
0x16	TCC0	OVF	DMA overflow/underflow/retrigger trigger
0x1C - 0x17	TCC0	MC	Indexes of DMA Match/Compare triggers
0x1D	TCC1	OVF	DMA overflow/underflow/retrigger trigger
0x21- 0x1E	TCC1	MC	Indexes of DMA Match/Compare triggers
0x22	TCC2	OVF	DMA overflow/underflow/retrigger trigger
0x25 - 0x23	TCC2	MC	Indexes of DMA Match/Compare triggers
0x26	TCC3	OVF	DMA overflow/underflow/retrigger trigger
0x28 - 0x27	TCC3	MC	Indexes of DMA Match/Compare triggers
0x29	TCC4	OVF	DMA overflow/underflow/retrigger trigger
0x2B - 0x2A	TCC4	MC	Indexes of DMA Match/Compare triggers
0x2C	TC0	OVF	Indexes of DMA Overflow trigger
0x2E - 0x2D	TC0	MC	Indexes of DMA Match/Compare triggers
0x2F	TC1	OVF	Indexes of DMA Overflow trigger
0x31 - 0x30	TC1	MC	Indexes of DMA Match/Compare triggers
0x32	TC2	OVF	Indexes of DMA Overflow trigger
0x34 - 0x33	TC2	MC	Indexes of DMA Match/Compare triggers
0x35	TC3	OVF	Indexes of DMA Overflow trigger
0x37 - 0x36	TC3	MC	Indexes of DMA Match/Compare triggers
0x38	TC4	OVF	Indexes of DMA Overflow trigger
0x3A - 0x39	TC4	MC	Indexes of DMA Match/Compare triggers
0x3B	TC5	OVF	Indexes of DMA Overflow trigger
0x3D:0x3C	TC5	MC	Indexes of DMA Match/Compare triggers
0x3E	TC6	OVF	Indexes of DMA Overflow trigger
0x40 - 0x3F	TC6	MC	Indexes of DMA Match/Compare triggers
0x41	TC7	OVF	Indexes of DMA Overflow trigger
0x43 - 0x41	TC7	MC	Indexes of DMA Match/Compare triggers

# SAM D5x/E5x Family Data Sheet

## DMAC – Direct Memory Access Controller

.....continued

Index	Instance	Channel	Presentation
0x44	ADC0	RESRDY	index of DMA RESRDY trigger
0x45	ADC0	SEQ	Index of DMA SEQ trigger
0x46	ADC1	RESRDY	Index of DMA RESRDY trigger
0x47	ADC1	SEQ	Index of DMA SEQ trigger
0x49 - 0x48	DAC	EMPTY	DMA DAC Empty Req
0x4B - 0x4A	DAC	RESRDY	DMA DAC Result Ready Req
0x4D - 0x4C	I2S	RX	Indexes of DMA RX triggers
0x4F - 0x4E	I2S	TX	Indexes of DMA TX triggers
0x50	PCC	RX	Indexes of PCC RX trigger
0x51	AES	WR	DMA DATA Write trigger
0x52	AES	RD	DMA DATA Read trigger
0x53	QSPI	RX	Indexes of QSPI RX trigger
0x54	QSPI	TX	Indexes of QSPI TX trigger

### Bit 6 – RUNSTDBY Channel run in standby

This bit is used to keep the DMAC channel running in standby mode.

This bit is not enable-protected.

Value	Description
0	The DMAC channel is halted in standby.
1	The DMAC channel continues to run in standby.

### Bit 1 – ENABLE Channel Enable

Writing a '0' to this bit during an ongoing transfer, the bit will not be cleared until the internal data transfer buffer is empty and the DMA transfer is aborted. The internal data transfer buffer will be empty once the ongoing burst transfer is completed.

Writing a '1' to this bit will enable the DMA channel.

This bit is not enable-protected.

Value	Description
0	DMA channel is disabled.
1	DMA channel is enabled.

### Bit 0 – SWRST Channel Software Reset

Writing a '0' to this bit has no effect.

Writing a '1' to this bit resets the channel registers to their initial state. The bit can be set when the channel is disabled (ENABLE=0). Writing a '1' to this bit will be ignored as long as ENABLE=1. This bit is automatically cleared when the reset is completed.

Value	Description
0	There is no reset operation ongoing.
1	The reset operation is ongoing.

# SAM D5x/E5x Family Data Sheet

## DMAC – Direct Memory Access Controller

### 22.8.17 Channel Control B

**Name:** CHCTRLB  
**Offset:** 0x44 + n\*0x10 [n=0..31]  
**Reset:** 0x00  
**Property:** PAC Write-Protection

	7	6	5	4	3	2	1	0
							CMD[1:0]	
Access							R/W	R/W
Reset							0	0

#### Bits 1:0 – CMD[1:0] Software Command

These bits define the software commands. Refer to [22.6.3.3 Channel Suspend](#) and [22.6.3.4 Channel Resume and Next Suspend Skip](#).

These bits are not enable-protected.

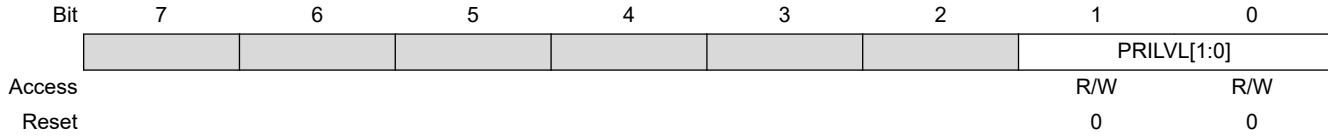
CMD[1:0]	Name	Description
0x0	NOACT	No action
0x1	SUSPEND	Channel suspend operation
0x2	RESUME	Channel resume operation
0x3	-	Reserved

# SAM D5x/E5x Family Data Sheet

## DMAC – Direct Memory Access Controller

### 22.8.18 Channel Priority Level

**Name:** CHPRILVL  
**Offset:** 0x45 + n\*0x10 [n=0..31]  
**Reset:** 0x00  
**Property:** PAC Write-Protection



#### Bits 1:0 – PRILVL[1:0] Channel Priority Level

These bits define the priority level used for the DMA channel. The available levels are shown below, where a high level has priority over a low level. These bits are not enable-protected.

Value	Name	Description
0x0	LVL0	Channel Priority Level 0 (Lowest Level)
0x1	LVL1	Channel Priority Level 1
0x2	LVL2	Channel Priority Level 2
0x3	LVL3	Channel Priority Level 3 (Highest Level)

# SAM D5x/E5x Family Data Sheet

## DMAC – Direct Memory Access Controller

### 22.8.19 Channel Event Control

**Name:** CHEVCTRL  
**Offset:** 0x46 + n\*0x10 [n=0..31]  
**Reset:** 0x00  
**Property:** PAC Write-Protection, Enable-Protected

	7	6	5	4	3	2	1	0
	EVOE	EVIE	EVOMODE[1:0]			EVACT[2:0]		
Access	R/W	R/W	R/W	R/W		R/W	R/W	R/W
Reset	0	0	0	0		0	0	0

#### Bit 7 – EVOE Channel Event Output Enable

This bit indicates if the Channel event generation is enabled. The event will be generated for every condition defined in the Channel Event Output Selection bits (CHEVCTRL.EVOMODE).

Value	Description
0	Channel event generation is disabled.
1	Channel event generation is enabled.

#### Bit 6 – EVIE Channel Event Input Enable

Value	Description
0	Channel event action will not be executed on any incoming event.
1	Channel event action will be executed on any incoming event.

#### Bits 5:4 – EVOMODE[1:0] Channel Event Output Mode

These bits define the channel event output selection. For details on event output generation, refer to [22.6.3.6 Event Output Selection](#).

Value	Name	Description
0x0	DEFAULT	Block event output selection. Refer to <a href="#">BTCTRL.EVOSEL</a> for available selections.
0x1	TRIGACT	Ongoing trigger action
0x2–0x3		Reserved

#### Bits 2:0 – EVACT[2:0] Channel Event Input Action

These bits define the event input action. The action is executed only if the corresponding EVIE bit in the CHEVCTRL register of the channel is set. For details on event actions, refer to [22.6.3.5 Event Input Actions](#). These bits are available only for channels with event input support.

Value	Name	Description
0x0	NOACT	No action
0x1	TRIG	Transfer and periodic transfer trigger
0x2	CTRIG	Conditional transfer trigger
0x3	CBLOCK	Conditional block transfer
0x4	SUSPEND	Channel suspend operation
0x5	RESUME	Channel resume operation
0x6	SSKIP	Skip next block suspend action
0x7	INCPRI	Increase priority

# SAM D5x/E5x Family Data Sheet

## DMAC – Direct Memory Access Controller

### 22.8.20 Channel Interrupt Enable Clear

**Name:** CHINTENCLR  
**Offset:** 0x4C + n\*0x10 [n=0..31]  
**Reset:** 0x00  
**Property:** PAC Write-Protection

This register allows the user to disable an interrupt without doing a read-modify-write operation. Changes in this register will also be reflected in the Channel Interrupt Enable Set (CHINTENSET) register.

	Bit	7	6	5	4	3	2	1	0
							SUSP	TCMPL	TERR
Access							R/W	R/W	R/W
Reset							0	0	0

#### Bit 2 – SUSP Channel Suspend Interrupt Enable

Writing a '0' to this bit has no effect.

Writing a '1' to this bit will clear the Channel Suspend Interrupt Enable bit, which disables the Channel Suspend interrupt.

Value	Description
0	The Channel Suspend interrupt is disabled.
1	The Channel Suspend interrupt is enabled.

#### Bit 1 – TCMPL Channel Transfer Complete Interrupt Enable

Writing a '0' to this bit has no effect.

Writing a '1' to this bit will clear the Channel Transfer Complete Interrupt Enable bit, which disables the Channel Transfer Complete interrupt.

Value	Description
0	The Channel Transfer Complete interrupt is disabled. When block action is set to none, the TCMPL flag will not be set when a block transfer is completed.
1	The Channel Transfer Complete interrupt is enabled.

#### Bit 0 – TERR Channel Transfer Error Interrupt Enable

Writing a '0' to this bit has no effect.

Writing a '1' to this bit will clear the Channel Transfer Error Interrupt Enable bit, which disables the Channel Transfer Error interrupt.

Value	Description
0	The Channel Transfer Error interrupt is disabled.
1	The Channel Transfer Error interrupt is enabled.

### 22.8.21 Channel Interrupt Enable Set

**Name:** CHINTENSET  
**Offset:** 0x4D + n\*0x10 [n=0..31]  
**Reset:** 0x00  
**Property:** PAC Write-Protection

This register allows the user to enable an interrupt without doing a read-modify-write operation. Changes in this register will also be reflected in the Channel Interrupt Enable Clear (CHINTENCLR) register.

	7	6	5	4	3	2	1	0
						SUSP	TCMPL	TERR
Access						R/W	R/W	R/W
Reset						0	0	0

#### Bit 2 – SUSP Channel Suspend Interrupt Enable

Writing a '0' to this bit has no effect.

Writing a '1' to this bit will set the Channel Suspend Interrupt Enable bit, which enables the Channel Suspend interrupt.

Value	Description
0	The Channel Suspend interrupt is disabled.
1	The Channel Suspend interrupt is enabled.

#### Bit 1 – TCMPL Channel Transfer Complete Interrupt Enable

Writing a '0' to this bit has no effect.

Writing a '1' to this bit will set the Channel Transfer Complete Interrupt Enable bit, which enables the Channel Transfer Complete interrupt.

Value	Description
0	The Channel Transfer Complete interrupt is disabled.
1	The Channel Transfer Complete interrupt is enabled.

#### Bit 0 – TERR Channel Transfer Error Interrupt Enable

Writing a '0' to this bit has no effect.

Writing a '1' to this bit will set the Channel Transfer Error Interrupt Enable bit, which enables the Channel Transfer Error interrupt.

Value	Description
0	The Channel Transfer Error interrupt is disabled.
1	The Channel Transfer Error interrupt is enabled.



### 22.8.22 Channel Interrupt Flag Status and Clear

**Name:** CHINTFLAG  
**Offset:** 0x4E + n\*0x10 [n=0..31]  
**Reset:** 0x00  
**Property:** -

	7	6	5	4	3	2	1	0
Bit						SUSP	TCMPL	TERR
Access						R/W	R/W	R/W
Reset						0	0	0

#### Bit 2 – SUSP Channel Suspend

This flag is cleared by writing a '1' to it.

This flag is set when a block transfer with suspend block action is completed, when a software suspend command is executed, when a suspend event is received or when an invalid descriptor is fetched by the DMA.

Writing a '0' to this bit has no effect.

Writing a '1' to this bit will clear the Channel Suspend interrupt flag for the corresponding channel.

For details on available software commands, refer to [CHCTRLB.CMD](#).

For details on available event input actions, refer to [CHCTRLB.EVACT](#).

For details on available block actions, refer to [BTCTRL.BLOCKACT](#).

#### Bit 1 – TCMPL Channel Transfer Complete

This flag is cleared by writing a '1' to it.

This flag is set when a block transfer is completed and the corresponding interrupt block action is enabled.

Writing a '0' to this bit has no effect.

Writing a '1' to this bit will clear the Transfer Complete interrupt flag for the corresponding channel.

#### Bit 0 – TERR Channel Transfer Error

This flag is cleared by writing a '1' to it.

This flag is set when a bus error is detected during a beat transfer or when the DMAC fetches an invalid descriptor.

Writing a '0' to this bit has no effect.

Writing a '1' to this bit will clear the Transfer Error interrupt flag for the corresponding channel.

# SAM D5x/E5x Family Data Sheet

## DMAC – Direct Memory Access Controller

### 22.8.23 Channel Status

**Name:** CHSTATUS  
**Offset:** 0x4F + n\*0x10 [n=0..31]  
**Reset:** 0x00  
**Property:** -

	7	6	5	4	3	2	1	0
					CRCERR	FERR	BUSY	PEND
Access					R/W	R	R	R
Reset					0	0	0	0

**Bit 3 – CRCERR** Channel CRC Error

This bit is set when the CRC monitor detects data corruption. This bit is cleared by writing '1' to it, or by clearing the CRC Error bit in the INTPEND register ([INTPEND.CRCERR](#)).

**Bit 2 – FERR** Channel Fetch Error

This bit is cleared when a software resume command is executed.  
 This bit is set when an invalid descriptor is fetched.

**Bit 1 – BUSY** Channel Busy

This bit is cleared when the channel trigger action is completed, when a bus error is detected or when the channel is disabled.  
 This bit is set when the DMA channel starts a DMA transfer.

**Bit 0 – PEND** Channel Pending

This bit is cleared when the channel trigger action is started, when a bus error is detected or when the channel is disabled. For details on trigger action settings, refer to [CHCTRLB.TRIGACT](#).  
 This bit is set when a transfer is pending on the DMA channel, as soon as the transfer request is received.

# SAM D5x/E5x Family Data Sheet

## DMAC – Direct Memory Access Controller

### 22.9 Register Summary - SRAM

Offset	Name	Bit Pos.								
0x00	BTCTRL	7:0				BLOCKACT[1:0]		EVOSEL[1:0]		VALID
		15:8	STEPSIZE[2:0]			STEPSEL	DSTINC	SRCINC	BEATSIZE[1:0]	
0x02	BTCNT	7:0	BTCNT[7:0]							
		15:8	BTCNT[15:8]							
0x04	SRCADDR	7:0	SRCADDR[7:0]							
		15:8	SRCADDR[15:8]							
		23:16	SRCADDR[23:16]							
		31:24	SRCADDR[31:24]							
0x08	DSTADDR	7:0	DSTADDR[7:0]							
		15:8	DSTADDR[15:8]							
		23:16	DSTADDR[23:16]							
		31:24	DSTADDR[31:24]							
0x0C	DESCADDR	7:0	DESCADDR[7:0]							
		15:8	DESCADDR[15:8]							
		23:16	DESCADDR[23:16]							
		31:24	DESCADDR[31:24]							

### 22.10 Register Description - SRAM

Registers can be 8, 16, or 32 bits wide. Atomic 8-, 16- and 32-bit accesses are supported. In addition, the 8-bit quarters and 16-bit halves of a 32-bit register, and the 8-bit halves of a 16-bit register can be accessed directly.

Some registers are optionally write-protected by the Peripheral Access Controller (PAC). Optional PAC write protection is denoted by the "PAC Write-Protection" property in each individual register description. For details, refer to [22.5.8 Register Access Protection](#).

Some registers are enable-protected, meaning they can only be written when the peripheral is disabled. Enable-protection is denoted by the "Enable-Protected" property in each individual register description.

# SAM D5x/E5x Family Data Sheet

## DMAC – Direct Memory Access Controller

### 22.10.1 Block Transfer Control

**Name:** BTCTRL  
**Offset:** 0x00  
**Property:** -

The BTCTRL register offset is relative to (BASEADDR or WRBADDR) + Channel Number \* 0x10

	15	14	13	12	11	10	9	8
	STEPSIZE[2:0]			STEPSEL	DSTINC	SRCINC	BEATSIZE[1:0]	
Access								
Reset								
	7	6	5	4	3	2	1	0
				BLOCKACT[1:0]		EVOSEL[1:0]		VALID
Access								
Reset								

#### Bits 15:13 – STEPSIZE[2:0] Address Increment Step Size

These bits select the address increment step size. The setting apply to source or destination address, depending on STEPSEL setting.

Value	Name	Description
0x0	X1	Next ADDR = ADDR + (Beat size in byte) * 1
0x1	X2	Next ADDR = ADDR + (Beat size in byte) * 2
0x2	X4	Next ADDR = ADDR + (Beat size in byte) * 4
0x3	X8	Next ADDR = ADDR + (Beat size in byte) * 8
0x4	X16	Next ADDR = ADDR + (Beat size in byte) * 16
0x5	X32	Next ADDR = ADDR + (Beat size in byte) * 32
0x6	X64	Next ADDR = ADDR + (Beat size in byte) * 64
0x7	X128	Next ADDR = ADDR + (Beat size in byte) * 128

#### Bit 12 – STEPSEL Step Selection

This bit selects if source or destination addresses are using the step size settings.

Value	Name	Description
0x0	DST	Step size settings apply to the destination address
0x1	SRC	Step size settings apply to the source address

#### Bit 11 – DSTINC Destination Address Increment Enable

Writing a '0' to this bit will disable the destination address incrementation. The address will be kept fixed during the data transfer.

Writing a '1' to this bit will enable the destination address incrementation. By default, the destination address is incremented by 1. If the STEPSEL bit is cleared, flexible step-size settings are available in the STEPSIZE register.

Value	Description
0	The Destination Address Increment is disabled
1	The Destination Address Increment is enabled

# SAM D5x/E5x Family Data Sheet

## DMAC – Direct Memory Access Controller

### Bit 10 – SRCINC Source Address Increment Enable

Writing a '0' to this bit will disable the source address incrementation. The address will be kept fixed during the data transfer.

Writing a '1' to this bit will enable the source address incrementation. By default, the source address is incremented by 1. If the STEPSEL bit is set, flexible step-size settings are available in the STEPSIZE register.

Value	Description
0	The Source Address Increment is disabled
1	The Source Address Increment is enabled

### Bits 9:8 – BEATSIZE[1:0] Beat Size

These bits define the size of one beat. A beat is the size of one data transfer bus access, and the setting apply to both read and write accesses.

Value	Name	Description
0x0	BYTE	8-bit bus transfer
0x1	HWORDB	16-bit bus transfer
0x2	WORD	32-bit bus transfer
other		Reserved

### Bits 4:3 – BLOCKACT[1:0] Block Action

These bits define what actions the DMAC should take after a block transfer has completed.

BLOCKACT[1:0]	Name	Description
0x0	NOACT	Channel will be disabled if it is the last block transfer in the transaction
0x1	INT	Channel will be disabled if it is the last block transfer in the transaction and block interrupt
0x2	SUSPEND	Channel suspend operation is completed
0x3	BOTH	Both channel suspend operation and block interrupt

### Bits 2:1 – EVOSEL[1:0] Event Output Selection

These bits define the event output selection.

EVOSEL[1:0]	Name	Description
0x0	DISABLE	Event generation disabled
0x1	BLOCK	Event strobe when block transfer complete
0x2		Reserved
0x3	BEAT	Event strobe when beat transfer complete

### Bit 0 – VALID Descriptor Valid

Writing a '0' to this bit in the Descriptor or Write-Back memory will suspend the DMA channel operation when fetching the corresponding descriptor.

The bit is automatically cleared in the Write-Back memory section when channel is aborted, when an error is detected during the block transfer, or when the block transfer is completed.

Value	Description
0	The descriptor is not valid

# SAM D5x/E5x Family Data Sheet

## DMAC – Direct Memory Access Controller

---

---

Value	Description
1	The descriptor is valid

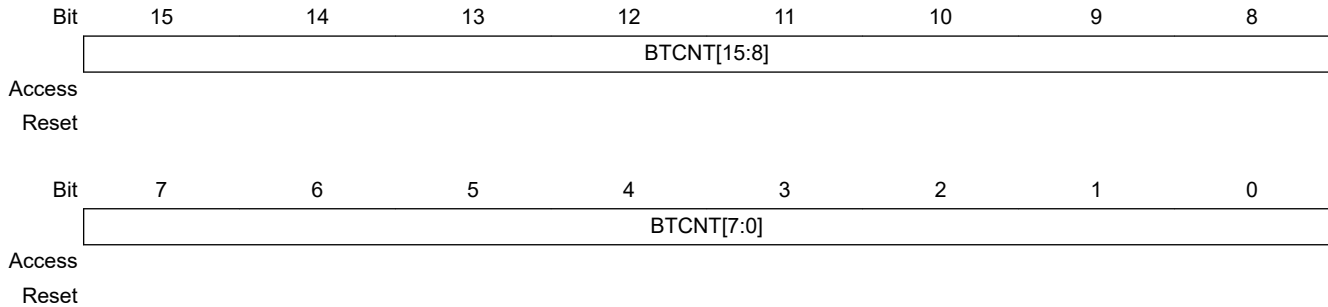
# SAM D5x/E5x Family Data Sheet

## DMAC – Direct Memory Access Controller

### 22.10.2 Block Transfer Count

**Name:** BTCNT  
**Offset:** 0x02  
**Property:** -

The BTCNT register offset is relative to (BASEADDR or WRBADDR) + Channel Number \* 0x10



#### Bits 15:0 – BTCNT[15:0] Block Transfer Count

This bit group holds the 16-bit block transfer count.

During a transfer, the internal counter value is decremented by one after each beat transfer. The internal counter is written to the corresponding write-back memory section for the DMA channel when the DMA channel loses priority, is suspended or gets disabled. The DMA channel can be disabled by a complete transfer, a transfer error or by software.

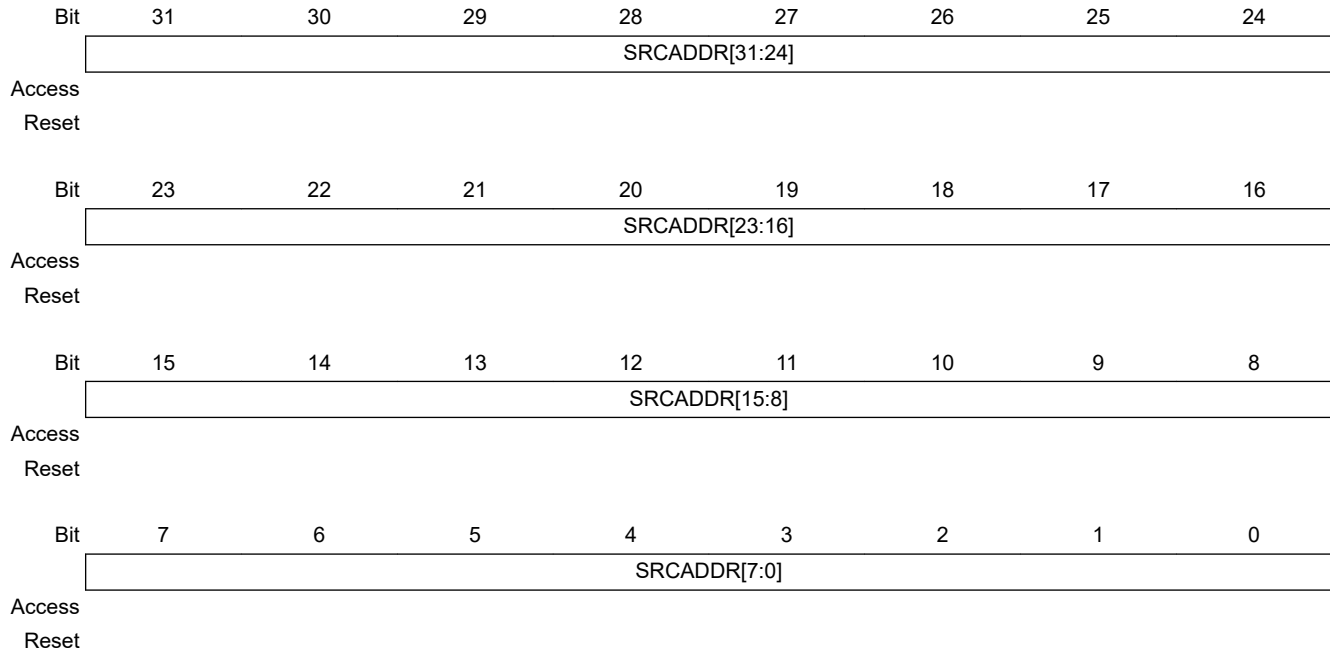
# SAM D5x/E5x Family Data Sheet

## DMAC – Direct Memory Access Controller

### 22.10.3 Block Transfer Source Address

**Name:** SRCADDR  
**Offset:** 0x04  
**Property:** -

The SRCADDR register offset is relative to (BASEADDR or WRBADDR) + Channel Number \* 0x10



#### **Bits 31:0 – SRCADDR[31:0]** Transfer Source Address

This bit group holds the source address corresponding to the last beat transfer address in the block transfer.



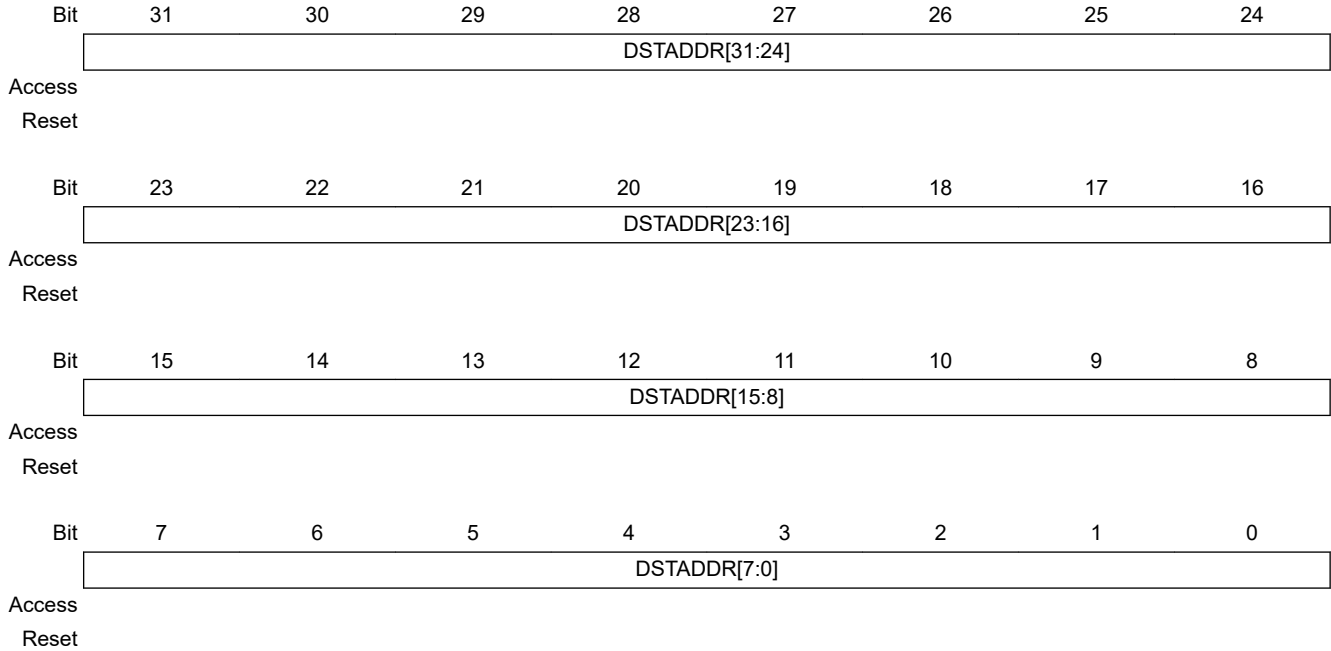
# SAM D5x/E5x Family Data Sheet

## DMAC – Direct Memory Access Controller

### 22.10.4 Block Transfer Destination Address

**Name:** DSTADDR  
**Offset:** 0x08  
**Property:** -

The DSTADDR register offset is relative to (BASEADDR or WRBADDR) + Channel Number \* 0x10



#### Bits 31:0 – DSTADDR[31:0] Transfer Destination Address

This bit group holds the destination address corresponding to the last beat transfer address in the block transfer.

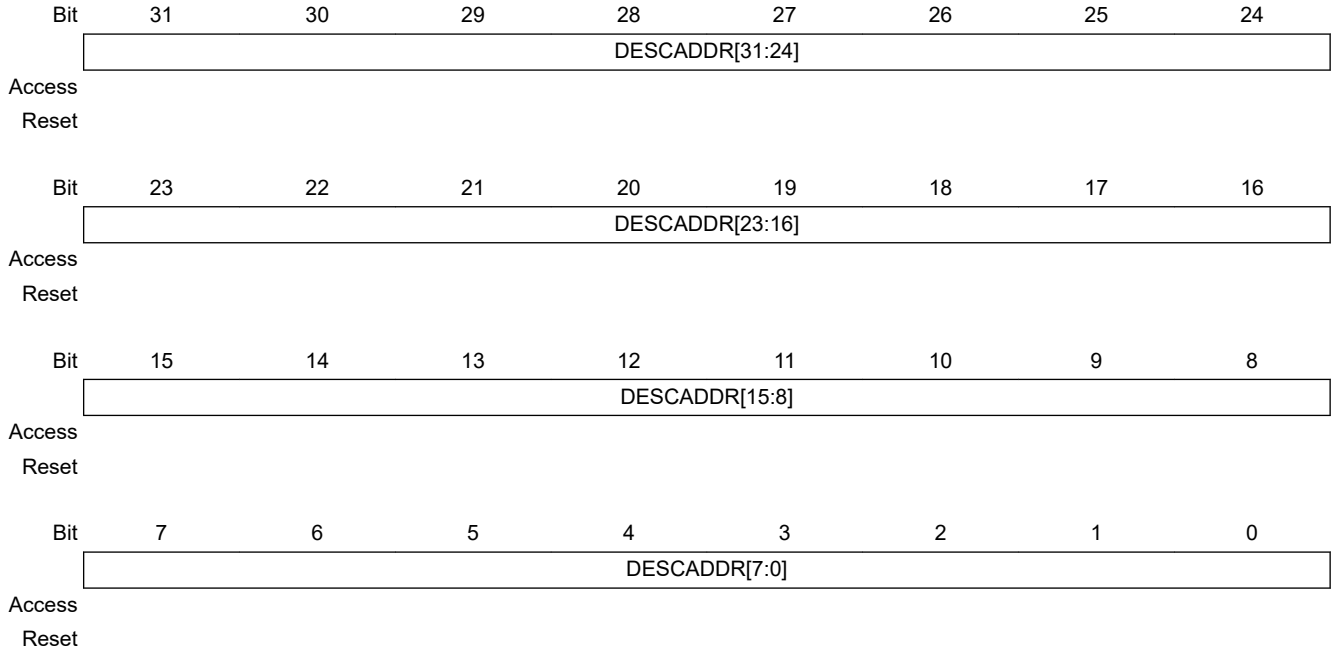
# SAM D5x/E5x Family Data Sheet

## DMAC – Direct Memory Access Controller

### 22.10.5 Next Descriptor Address

**Name:** DESCADDR  
**Offset:** 0x0C  
**Property:** -

The DESCADDR register offset is relative to (BASEADDR or WRBADDR) + Channel Number \* 0x10



#### Bits 31:0 – DESCADDR[31:0] Next Descriptor Address

This bit group holds the SRAM address of the next descriptor. The value must be 128-bit aligned. If the value of this SRAM register is 0x00000000, the transaction will be terminated when the DMAC tries to load the next transfer descriptor.

## 23. EIC – External Interrupt Controller

### 23.1 Overview

The External Interrupt Controller (EIC) allows external pins to be configured as interrupt lines. Each interrupt line can be individually masked and can generate an interrupt on rising, falling, both edges, or on high or low levels. Each external pin has a configurable filter to remove spikes. Also, each external pin can be configured to be asynchronous in order to wake-up the device from Sleep modes where all clocks have been disabled. External pins can generate an event.

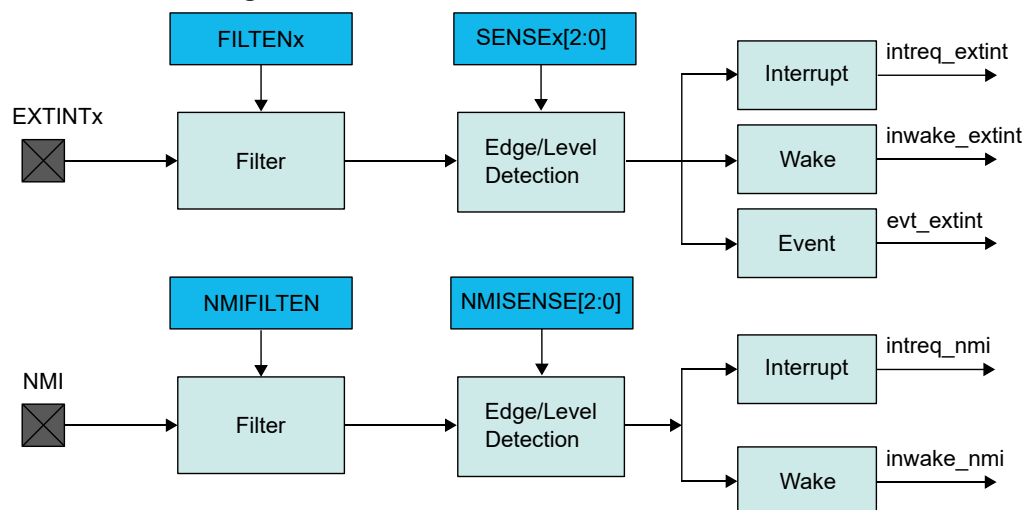
A separate Non-Maskable Interrupt (NMI) is supported. It has properties similar to the other external interrupts, but is connected to the NMI request of the CPU, enabling it to interrupt any other Interrupt mode.

### 23.2 Features

- Up to 16 external pins (EXTINTx), plus one non-maskable pin (NMI)
- Dedicated, Individually Maskable Interrupt for Each Pin
- Interrupt on Rising, Falling, or Both Edges
- Synchronous or Asynchronous Edge Detection mode
- Interrupt pin Debouncing
- Interrupt on High or Low Levels
- Asynchronous Interrupts for Sleep Modes Without Clock
- Filtering of External Pins
- Event Generation from EXTINTx

### 23.3 Block Diagram

Figure 23-1. EIC Block Diagram



### 23.4 Signal Description

Signal Name	Type	Description
EXTINT[15..0]	Digital Input	External interrupt pin
NMI	Digital Input	Non-maskable interrupt pin

One signal may be available on several pins.

### 23.5 Product Dependencies

In order to use this peripheral, other parts of the system must be configured correctly, as described below.

#### 23.5.1 I/O Lines

Using the EIC's I/O lines requires the I/O pins to be configured.

##### Related Links

[32. PORT - I/O Pin Controller](#)

#### 23.5.2 Power Management

All interrupts are available down to STANDBY Sleep mode, but the EIC can be configured to automatically mask some interrupts in order to prevent device wake-up.

The EIC will continue to operate in any Sleep mode where the selected source clock is running. The EIC's interrupts can be used to wake up the device from Sleep modes. Events connected to the Event System can trigger other operations in the system without exiting Sleep modes.

##### Related Links

[18. PM – Power Manager](#)

#### 23.5.3 Clocks

The EIC bus clock (CLK\_EIC\_APB) can be enabled and disabled by the Main Clock Controller, the default state of CLK\_EIC\_APB can be found in the Peripheral Clock Masking section.

Some optional functions need a peripheral clock, which can either be a generic clock (GCLK\_EIC, for wider frequency selection) or a Ultra Low-Power 32 KHz clock (CLK\_ULP32K, for highest power efficiency). One of the clock sources must be configured and enabled before using the peripheral:

GCLK\_EIC is configured and enabled in the Generic Clock Controller.

CLK\_ULP32K is provided by the internal Ultra Low-Power (OSCULP32K) Oscillator in the OSC32KCTRL module.

Both GCLK\_EIC and CLK\_ULP32K are asynchronous to the user interface clock (CLK\_EIC\_APB). Due to this asynchronicity, writes to certain registers will require synchronization between the clock domains. Refer to [Synchronization](#) for further details.

##### Related Links

[15. MCLK – Main Clock](#)

[15.6.2.6 Peripheral Clock Masking](#)

[14. GCLK - Generic Clock Controller](#)

[29. OSC32KCTRL – 32KHz Oscillators Controller](#)

### 23.5.4 DMA

Not applicable.

### 23.5.5 Interrupts

There are several interrupt request lines, at least one for the external interrupts (EXTINT) and one for Non-Maskable Interrupt (NMI).

The EXTINT interrupt request line is connected to the interrupt controller. Using the EIC interrupt requires the interrupt controller to be configured first.

The NMI interrupt request line is connected to the interrupt controller, but does not require the interrupt to be configured.

#### Related Links

[10.2 Nested Vector Interrupt Controller](#)

### 23.5.6 Events

The events are connected to the Event System. Using the events requires the Event System to be configured first.

#### Related Links

[31. EVSYS – Event System](#)

### 23.5.7 Debug Operation

When the CPU is halted in Debug mode, the EIC continues normal operation. If the EIC is configured in a way that requires it to be periodically serviced by the CPU through interrupts or similar, improper operation or data loss may result during debugging.

### 23.5.8 Register Access Protection

All registers with write access can be write-protected optionally by the Peripheral Access Controller (PAC), except for the following registers:

- Interrupt Flag Status and Clear register (INTFLAG)
- Non-Maskable Interrupt Flag Status and Clear register (NMIFLAG)

Optional write protection by the Peripheral Access Controller (PAC) is denoted by the "PAC Write Protection" property in each individual register description.

PAC write protection does not apply to accesses through an external debugger.

#### Related Links

[27. PAC - Peripheral Access Controller](#)

### 23.5.9 Analog Connections

Not applicable.

## 23.6 Functional Description

### 23.6.1 Principle of Operation

The EIC detects edge or level condition to generate interrupts to the CPU interrupt controller or events to the Event System. Each external interrupt pin (EXTINT) can be filtered using majority vote filtering, clocked by GCLK\_EIC or by CLK\_ULP32K.

---

### Related Links

[23.6.3 External Pin Processing](#)

## 23.6.2 Basic Operation

### 23.6.2.1 Initialization

The EIC must be initialized in the following order:

1. Enable CLK\_EIC\_APB
2. If required, configure the NMI by writing the Non-Maskable Interrupt Control register (NMICTRL)
3. Enable GCLK\_EIC or CLK\_ULP32K when one of the following configuration is selected:
  - the NMI uses edge detection or filtering.
  - one EXTINT uses filtering.
  - one EXTINT uses synchronous edge detection.
  - one EXTINT uses debouncing.

GCLK\_EIC is used when a frequency higher than 32KHz is required for filtering.

CLK\_ULP32K is recommended when power consumption is the priority. For CLK\_ULP32K write a '1' to the Clock Selection bit in the Control A register (CTRLA.CKSEL).

4. Configure the EIC input sense and filtering by writing the Configuration n register (CONFIG).
5. Optionally, enable the asynchronous mode.
6. Optionally, enable the debouncer mode.
7. Enable the EIC by writing a '1' to CTRLA.ENABLE.

The following bits are enable-protected, meaning that it can only be written when the EIC is disabled (CTRLA.ENABLE=0):

- Clock Selection bit in Control A register ([CTRLA.CKSEL](#))

The following registers are enable-protected:

- Event Control register (EVCTRL)
- Configuration n register (CONFIG).
- External Interrupt Asynchronous Mode register ([23.8.9 ASYNCH](#))
- Debouncer Enable register ([23.8.11 DEBOUNCEN](#))
- Debounce Prescaler register ([23.8.12 DPRESCALER](#))

Enable-protected bits in the [CTRLA](#) register can be written at the same time when setting [CTRLA.ENABLE](#) to '1', but not at the same time as [CTRLA.ENABLE](#) is being cleared.

Enable-protection is denoted by the "Enable-Protected" property in the register description.

### Related Links

[23.8.10 CONFIG](#)

### 23.6.2.2 Enabling, Disabling, and Resetting

The EIC is enabled by writing a '1' the Enable bit in the Control A register ([CTRLA.ENABLE](#)). The EIC is disabled by writing [CTRLA.ENABLE](#) to '0'.

The EIC is reset by setting the Software Reset bit in the Control register ([CTRLA.SWRST](#)). All registers in the EIC will be reset to their initial state, and the EIC will be disabled.

Refer to the [CTRLA](#) register description for details.

### 23.6.3 External Pin Processing

Each external pin can be configured to generate an interrupt/event on edge detection (rising, falling or both edges) or level detection (high or low). The sense of external interrupt pins is configured by writing the Input Sense x bits in the Configuration n register (CONFIG.SENSEx). The corresponding interrupt flag (INTFLAG.EXTINT[x]) in the Interrupt Flag Status and Clear register ([23.8.8 INTFLAG](#)) is set when the interrupt condition is met.

When the interrupt flag has been cleared in edge-sensitive mode, INTFLAG.EXTINT[x] will only be set if a new interrupt condition is met.

In level-sensitive mode, when interrupt has been cleared, INTFLAG.EXTINT[x] will be set immediately if the EXTINTx pin still matches the interrupt condition.

Each external pin can be filtered by a majority vote filtering, clocked by GCLK\_EIC or CLK\_ULP32K. Filtering is enabled if bit Filter Enable x in the Configuration n register (CONFIG.FILTENx) is written to '1'. The majority vote filter samples the external pin three times with GCLK\_EIC or CLK\_ULP32K and outputs the value when two or more samples are equal.

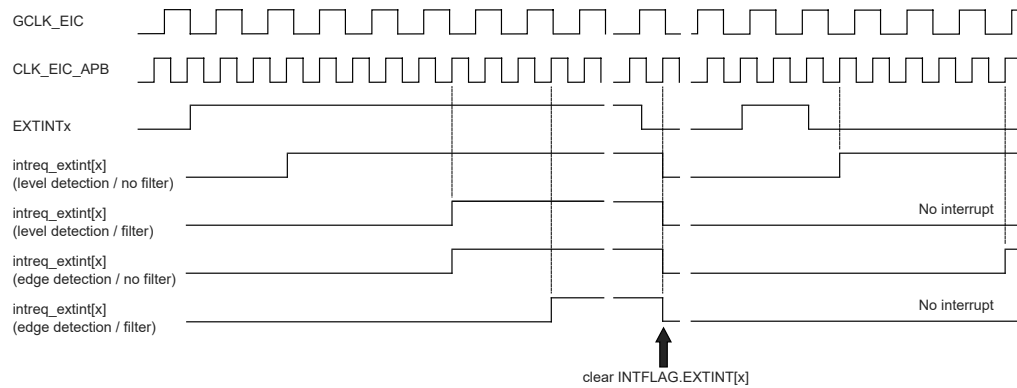
**Table 23-1. Majority Vote Filter**

Samples [0, 1, 2]	Filter Output
[0,0,0]	0
[0,0,1]	0
[0,1,0]	0
[0,1,1]	1
[1,0,0]	0
[1,0,1]	1
[1,1,0]	1
[1,1,1]	1

When an external interrupt is configured for level detection and when filtering is disabled, detection is done asynchronously. Level detection and asynchronous edge detection does not require GCLK\_EIC or CLK\_ULP32K, but interrupt and events can still be generated.

If filtering or synchronous edge detection or debouncing is enabled, the EIC automatically requests GCLK\_EIC or CLK\_ULP32K to operate. The selection between these two clocks is done by writing the Clock Selection bits in the Control A register ([CTRLA.CKSEL](#)). GCLK\_EIC must be enabled in the GCLK module. In these modes the external pin is sampled at the EIC clock rate, thus pulses with duration lower than two EIC clock periods may not be properly detected.

**Figure 23-2. Interrupt Detection Latency by modes (Rising Edge)**



The detection latency depends on the detection mode.

**Table 23-2. Detection Latency**

Detection mode	Latency (worst case)
Level without filter	Five CLK_EIC_APB periods
Level with filter	Four GCLK_EIC/CLK_ULP32K periods + five CLK_EIC_APB periods
Edge without filter	Four GCLK_EIC/CLK_ULP32K periods + five CLK_EIC_APB periods
Edge with filter	Six GCLK_EIC/CLK_ULP32K periods + five CLK_EIC_APB periods

### Related Links

[14. GCLK - Generic Clock Controller](#)

[23.8.10 CONFIG](#)

### 23.6.4 Additional Features

#### 23.6.4.1 Non-Maskable Interrupt (NMI)

The non-maskable interrupt pin can also generate an interrupt on edge or level detection, but it is configured with the dedicated NMI Control register (NMICTRL). To select the sense for NMI, write to the NMISENSE bit group in the NMI Control register (NMICTRL.NMISENSE). NMI filtering is enabled by writing a '1' to the NMI Filter Enable bit (NMICTRL.NMIFILTEN).

If edge detection or filtering is required, enable GCLK\_EIC or CLK\_ULP32K.

NMI detection is enabled only by the NMICTRL.NMISENSE value, and the EIC is not required to be enabled.

When an NMI is detected, the Non-maskable Interrupt flag in the NMI Flag Status and Clear register is set (NMIFLAG.NMI). NMI interrupt generation is always enabled, and NMIFLAG.NMI generates an interrupt request when set.

#### 23.6.4.2 Asynchronous Edge Detection Mode (No Debouncing)

The EXTINT edge detection can be operated synchronously or asynchronously, selected by the Asynchronous Control Mode bit for external pin x in the External Interrupt Asynchronous Mode register (ASYNCH.ASYNCH[x]). The EIC edge detection is operated synchronously when the Asynchronous Control Mode bit (ASYNCH.ASYNCH[x]) is '0' (default value). It is operated asynchronously when ASYNCH.ASYNCH[x] is written to '1'.



In *Synchronous Edge Detection Mode*, the external interrupt (EXTINT) or the non-maskable interrupt (NMI) pins are sampled using the EIC clock as defined by the Clock Selection bit in the Control A register (CTRLA.CKSEL). The External Interrupt flag (INTFLAG.EXTINT[x]) or Non-Maskable Interrupt flag (NMIFLAG.NMI) is set when the last sampled state of the pin differs from the previously sampled state. In this mode, the EIC clock is required.

The Synchronous Edge Detection Mode can be used in Idle and Standby sleep modes.

In *Asynchronous Edge Detection Mode*, the external interrupt (EXTINT) pins or the non-maskable interrupt (NMI) pins set the External Interrupt flag or Non-Maskable Interrupt flag (INTFLAG.EXTINT[x] or NMIFLAG) directly. In this mode, the EIC clock is not requested.

The asynchronous edge detection mode can be used in Idle and Standby sleep modes.

### 23.6.4.3 Interrupt Pin Debouncing

The external interrupt pin (EXTINT) edge detection can use a debouncer to improve input noise immunity. When selected, the debouncer can work in the synchronous mode or the asynchronous mode, depending on the configuration of the ASYNCH.ASYNCH[x] bit for the pin. The debouncer uses the EIC clock as defined by the bit CTRLA.CKSEL to clock the debouncing circuitry. The debouncing time frame is set with the debouncer prescaler DPRESALER.DPRESALERN, which provides the *low frequency clock* tick that is used to reject higher frequency signals.

The debouncing mode for pin EXTINT x can be selected only if the Sense bits in the Configuration y register (CONFIGy.SENSEx) are set to RISE, FALL or BOTH. If the debouncing mode for pin EXTINT x is selected, the filter mode for that pin (CONFIGy.FILTENx) can not be selected.

The debouncer manages an internal “valid pin state” that depends on the external interrupt (EXTINT) pin transitions, the debouncing mode and the debouncer prescaler frequency. The valid pin state reflects the pin value after debouncing. The external interrupt pin (EXTINT) is sampled continuously on EIC clock. The sampled value is evaluated on each *low frequency clock* tick to detect a transitional edge when the sampled value is different of the current valid pin state. The sampled value is evaluated on each EIC clock when DPRESALER.TICKON=0 or on each *low frequency clock* tick when DPRESALER.TICKON=1, to detect a bounce when the sampled value is equal to the current valid pin state. Transitional edge detection increments the transition counter of the EXTINT pin, while bounce detection resets the transition counter. The transition counter must exceed the transition count threshold as defined by the DPRESALER.STATESn bitfield. In the synchronous mode the threshold is 4 when DPRESALER.STATESn=0 or 8 when DPRESALER.STATESn=1. In the asynchronous mode the threshold is 4.

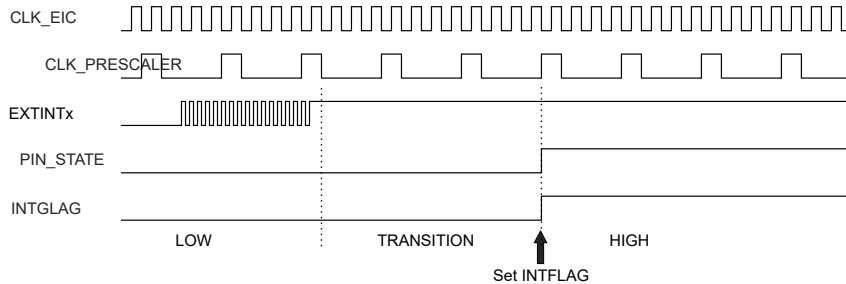
The valid pin state for the pins can be accessed by reading the register PINSTATE for both synchronous or asynchronous debouncing mode.

**Synchronous edge detection** In this mode the external interrupt (EXTINT) pin is sampled continuously on EIC clock.

1. A pin edge transition will be validated when the sampled value is consistently different of the current valid pin state for 4 (or 8 depending on bit DPRESALER.STATESn) consecutive ticks of the low frequency clock.
2. Any pin sample, at the *low frequency clock* tick rate, with a value opposite to the current valid pin state will increment the transition counter.
3. Any pin sample, at EIC clock rate (when DPRESALER.TICKON=0) or the *low frequency clock* tick (when DPRESALER.TICKON=1), with a value identical to the current valid pin state will return the transition counter to zero.

4. When the transition counter meets the count threshold, the pin edge transition is validated and the pin state `PINSTATE.PINSTATE[x]` is changed to the detected level.
5. The external interrupt flag (`INTFLAG.EXTINT[x]`) is set when the pin state `PINSTATE.PINSTATE[x]` is changed.

**Figure 23-3. EXTINT Pin Synchronous Debouncing (Rising Edge)**

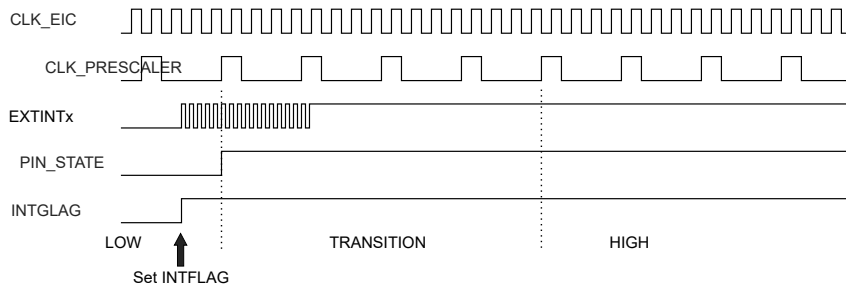


In the synchronous edge detection mode, the EIC clock is required. The synchronous edge detection mode can be used in Idle and Standby sleep modes.

**Asynchronous edge detection** In this mode, the external interrupt (EXTINT) pin directly drives an asynchronous edges detector which triggers any rising or falling edge on the pin:

1. Any edge detected that indicates a transition from the current valid pin state will immediately set the valid pin state `PINSTATE.PINSTATE[x]` to the detected level.
2. The external interrupt flag (`INTFLAG.EXTINT[x]`) is immediately changed.
3. The edge detector will then be idle until no other rising or falling edge transition is detected during 4 consecutive ticks of the low frequency clock.
4. Any rising or falling edge transition detected during the idle state will return the transition counter to 0.
5. After 4 consecutive ticks of the low frequency clock without bounce detected, the edge detector is ready for a new detection.

**Figure 23-4. EXTINT Pin Asynchronous Debouncing (Rising Edge)**



In this mode, the EIC clock is requested. The asynchronous edge detection mode can be used in Idle and Standby sleep modes.

### 23.6.5 DMA Operation

Not applicable.

### 23.6.6 Interrupts

The EIC has the following interrupt sources:

- External interrupt pins (`EXTINTx`). See [23.6.2 Basic Operation](#).
- Non-maskable interrupt pin (NMI). See [23.6.4 Additional Features](#).

Each interrupt source has an associated Interrupt flag. The interrupt flag in the Interrupt Flag Status and Clear register (INTFLAG) is set when an Interrupt condition occurs (NMIFLAG for NMI). Each interrupt, except NMI, can be individually enabled by setting the corresponding bit in the Interrupt Enable Set register (INTENSET=1), and disabled by setting the corresponding bit in the Interrupt Enable Clear register (INTENCLR=1).

An interrupt request is generated when the interrupt flag is set and the corresponding interrupt is enabled. The interrupt request remains active until the interrupt flag is cleared, the interrupt is disabled, or the EIC is reset. See the INTFLAG register for details on how to clear Interrupt flags. The EIC has one interrupt request line for each external interrupt (EXTINTx) and one line for NMI. The user must read the INTFLAG (or NMIFLAG) register to determine which Interrupt condition is present.

**Note:**

1. Interrupts must be globally enabled for interrupt requests to be generated.
2. If an external interrupts (EXTINT) is common on two or more I/O pins, only one will be active (the first one programmed).

**Related Links**

[10. Processor and Architecture](#)

### 23.6.7 Events

The EIC can generate the following output events:

- External event from pin (EXTINTx).

Setting an Event Output Control register (EVCTRL.EXTINTEO) enables the corresponding output event. Clearing this bit disables the corresponding output event. Refer to *Event System* for details on configuring the Event System.

When the condition on pin EXTINTx matches the configuration in the CONFIGn register, the corresponding event is generated, if enabled.

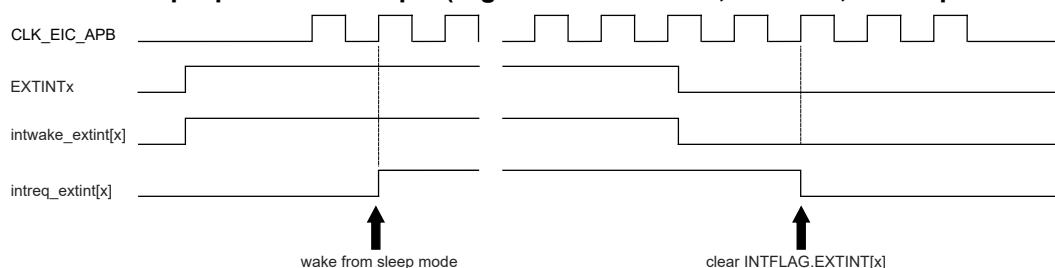
**Related Links**

[31. EVSYS – Event System](#)

### 23.6.8 Sleep Mode Operation

In sleep modes, an EXTINTx pin can wake up the device if the corresponding condition matches the configuration in the CONFIG register, and the corresponding bit in the Interrupt Enable Set register ([23.8.7 INTENSET](#)) is written to '1'.

**Figure 23-5. Wake-up Operation Example (High-Level Detection, No Filter, Interrupt Enable Set)**



**Related Links**

[23.8.10 CONFIG](#)

### 23.6.9 Synchronization

Due to asynchronicity between the main clock domain and the peripheral clock domains, some registers need to be synchronized when written or read.

The following bits are synchronized when written:

- Software Reset bit in control register ([CTRLA.SWRST](#))
- Enable bit in control register ([CTRLA.ENABLE](#))

Required write synchronization is denoted by the "Write-Synchronized" property in the register description.

# SAM D5x/E5x Family Data Sheet

## EIC – External Interrupt Controller

### 23.7 Register Summary

Offset	Name	Bit Pos.								
0x00	CTRLA	7:0				CKSEL			ENABLE	SWRST
0x01	NMICTRL	7:0				NMIASYNCH	NMIFILTEN	NMISENSE[2:0]		
0x02	NMIFLAG	7:0								NMI
		15:8								
0x04	SYNCBUSY	7:0							ENABLE	SWRST
		15:8								
		23:16								
		31:24								
0x08	EVCTRL	7:0	EXTINTEO[7:0]							
		15:8	EXTINTEO[15:8]							
		23:16								
		31:24								
0x0C	INTENCLR	7:0	EXTINT[7:0]							
		15:8	EXTINT[15:8]							
		23:16								
		31:24								
0x10	INTENSET	7:0	EXTINT[7:0]							
		15:8	EXTINT[15:8]							
		23:16								
		31:24								
0x14	INTFLAG	7:0	EXTINT[7:0]							
		15:8	EXTINT[15:8]							
		23:16								
		31:24								
0x18	ASYNCH	7:0	ASYNCH[7:0]							
		15:8	ASYNCH[15:8]							
		23:16								
		31:24								
0x1C	CONFIG0	7:0	FILTEN1	SENSE1[2:0]		FILTEN0	SENSE0[2:0]			
		15:8	FILTEN3	SENSE3[2:0]		FILTEN2	SENSE2[2:0]			
		23:16	FILTEN5	SENSE5[2:0]		FILTEN4	SENSE4[2:0]			
		31:24	FILTEN7	SENSE7[2:0]		FILTEN6	SENSE6[2:0]			
0x20	CONFIG1	7:0	FILTEN1	SENSE1[2:0]		FILTEN0	SENSE0[2:0]			
		15:8	FILTEN3	SENSE3[2:0]		FILTEN2	SENSE2[2:0]			
		23:16	FILTEN5	SENSE5[2:0]		FILTEN4	SENSE4[2:0]			
		31:24	FILTEN7	SENSE7[2:0]		FILTEN6	SENSE6[2:0]			
0x24 ... 0x2F	Reserved									
0x30	DEBOUNCEN	7:0	DEBOUNCEN[7:0]							
		15:8	DEBOUNCEN[15:8]							
		23:16								
		31:24								

# SAM D5x/E5x Family Data Sheet

## EIC – External Interrupt Controller

.....continued

Offset	Name	Bit Pos.							
0x34	DPRESCALER	7:0	STATES1	PRESCALER1[2:0]		STATES0	PRESCALER0[2:0]		
		15:8							
		23:16							TICKON
		31:24							
0x38	PINSTATE	7:0	PINSTATE[7:0]						
		15:8	PINSTATE[15:8]						
		23:16							
		31:24							

### 23.8 Register Description

Registers can be 8, 16, or 32 bits wide. Atomic 8-, 16-, and 32-bit accesses are supported. In addition, the 8-bit quarters and 16-bit halves of a 32-bit register, and the 8-bit halves of a 16-bit register can be accessed directly.

Some registers require synchronization when read and/or written. Synchronization is denoted by the "Read-Synchronized" and/or "Write-Synchronized" property in each individual register description.

Some registers are enable-protected, meaning they can only be written when the module is disabled. Enable protection is denoted by the "Enable-Protected" property in each individual register description.

### 23.8.1 Control A

**Name:** CTRLA  
**Offset:** 0x00  
**Reset:** 0x00  
**Property:** PAC Write-Protection, Write-Synchronized

	7	6	5	4	3	2	1	0
				CKSEL			ENABLE	SWRST
Access				RW			RW	W
Reset				0			0	0

#### Bit 4 – CKSEL Clock Selection

The EIC can be clocked either by GCLK\_EIC (when a frequency higher than 32KHz is required for filtering) or by CLK\_ULP32K (when power consumption is the priority).

This bit is not Write-Synchronized.

Value	Description
0	The EIC is clocked by GCLK_EIC.
1	The EIC is clocked by CLK_ULP32K.

#### Bit 1 – ENABLE Enable

Due to synchronization there is a delay between writing to CTRLA.ENABLE until the peripheral is enabled/disabled. The value written to CTRLA.ENABLE will read back immediately and the Enable bit in the Synchronization Busy register will be set (SYNCBUSY.ENABLE=1). SYNCBUSY.ENABLE will be cleared when the operation is complete.

This bit is not Enable-Protected.

This bit is Write-Synchronized.

Value	Description
0	The EIC is disabled.
1	The EIC is enabled.

#### Bit 0 – SWRST Software Reset

Writing a '0' to this bit has no effect.

Writing a '1' to this bit resets all registers in the EIC to their initial state, and the EIC will be disabled.

Writing a '1' to CTRLA.SWRST will always take precedence, meaning that all other writes in the same write operation will be discarded.

Due to synchronization there is a delay from writing CTRLA.SWRST until the Reset is complete.

CTRLA.SWRST and SYNCBUSY.SWRST will both be cleared when the Reset is complete.

This bit is not Enable-Protected.

This bit is Write-Synchronized.

Value	Description
0	There is no ongoing reset operation.
1	The reset operation is ongoing.

### 23.8.2 Non-Maskable Interrupt Control

**Name:** NMICTRL  
**Offset:** 0x01  
**Reset:** 0x00  
**Property:** PAC Write-Protection

	7	6	5	4	3	2	1	0
				NMIASYNCH	NMIFILTEN	NMISENSE[2:0]		
Access				R/W	R/W	R/W	R/W	R/W
Reset				0	0	0	0	0

#### Bit 4 – NMIASYNCH Asynchronous Edge Detection Mode

The NMI edge detection can be operated synchronously or asynchronously to the EIC clock.

Value	Description
0	The NMI edge detection is synchronously operated.
1	The NMI edge detection is asynchronously operated.

#### Bit 3 – NMIFILTEN Non-Maskable Interrupt Filter Enable

Value	Description
0	NMI filter is disabled.
1	NMI filter is enabled.

#### Bits 2:0 – NMISENSE[2:0] Non-Maskable Interrupt Sense Configuration

These bits define on which edge or level the NMI triggers.

Value	Name	Description
0x0	NONE	No detection
0x1	RISE	Rising-edge detection
0x2	FALL	Falling-edge detection
0x3	BOTH	Both-edge detection
0x4	HIGH	High-level detection
0x5	LOW	Low-level detection
0x6 – 0x7	-	Reserved

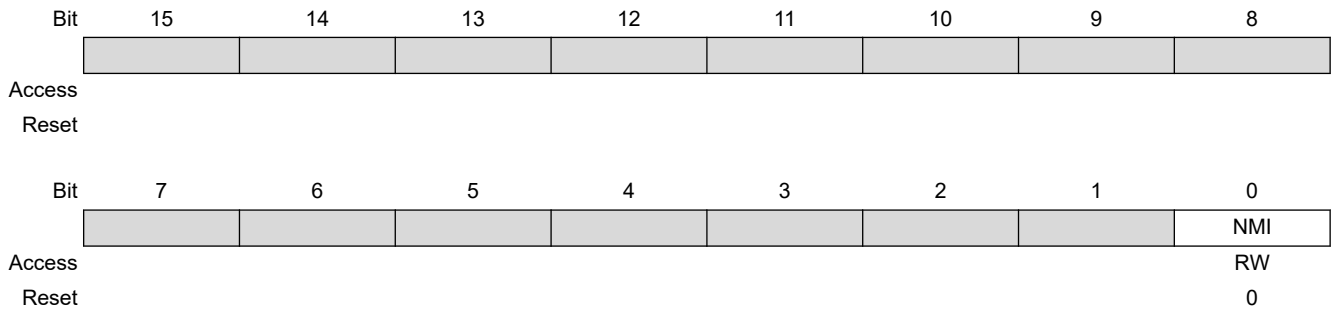


# SAM D5x/E5x Family Data Sheet

## EIC – External Interrupt Controller

### 23.8.3 Non-Maskable Interrupt Flag Status and Clear

**Name:** NMIFLAG  
**Offset:** 0x02  
**Reset:** 0x0000



#### Bit 0 – NMI Non-Maskable Interrupt

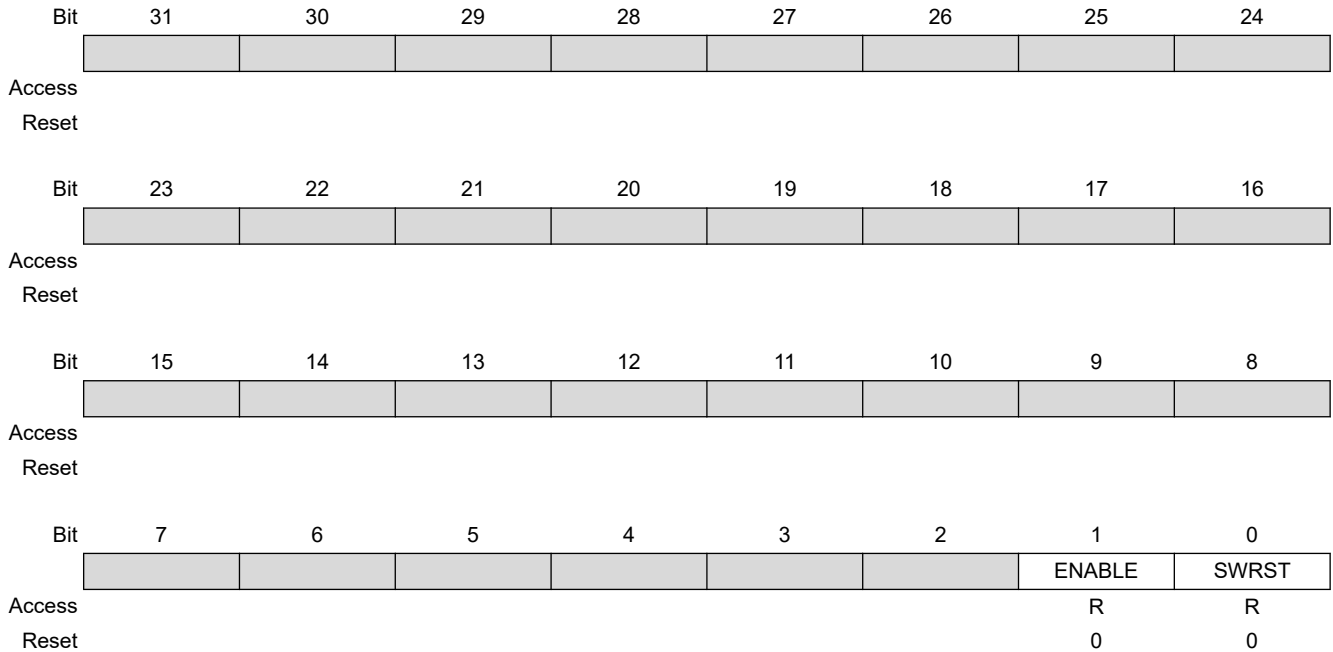
This flag is cleared by writing a '1' to it.

This flag is set when the NMI pin matches the NMI sense configuration, and will generate an interrupt request.

Writing a '0' to this bit has no effect.

### 23.8.4 Synchronization Busy

**Name:** SYNCBUSY  
**Offset:** 0x04  
**Reset:** 0x00000000



**Bit 1 – ENABLE** Enable Synchronization Busy Status

Value	Description
0	Write synchronization for <a href="#">CTRLA.ENABLE</a> bit is complete.
1	Write synchronization for <a href="#">CTRLA.ENABLE</a> bit is ongoing.

**Bit 0 – SWRST** Software Reset Synchronization Busy Status

Value	Description
0	Write synchronization for <a href="#">CTRLA.SWRST</a> bit is complete.
1	Write synchronization for <a href="#">CTRLA.SWRST</a> bit is ongoing.

# SAM D5x/E5x Family Data Sheet

## EIC – External Interrupt Controller

### 23.8.5 Event Control

**Name:** EVCTRL  
**Offset:** 0x08  
**Reset:** 0x00000000  
**Property:** PAC Write-Protection, Enable-Protected

Bit	31	30	29	28	27	26	25	24
Access								
Reset								
Bit	23	22	21	20	19	18	17	16
Access								
Reset								
Bit	15	14	13	12	11	10	9	8
Access	EXTINTEO[15:8]							
Reset	0	0	0	0	0	0	0	0
Bit	7	6	5	4	3	2	1	0
Access	EXTINTEO[7:0]							
Reset	0	0	0	0	0	0	0	0

#### Bits 15:0 – EXTINTEO[15:0] External Interrupt Event Output Enable

The bit x of EXTINTEO enables the event associated with the EXTINTx pin.

Value	Description
0	Event from pin EXTINTx is disabled.
1	Event from pin EXTINTx is enabled and will be generated when EXTINTx pin matches the external interrupt sensing configuration.

### 23.8.6 Interrupt Enable Clear

**Name:** INTENCLR  
**Offset:** 0x0C  
**Reset:** 0x00000000  
**Property:** PAC Write-Protection

This register allows the user to disable an interrupt without doing a read-modify-write operation. Changes in this register will also be reflected in the Interrupt Enable Set register (INTENSET).

Bit	31	30	29	28	27	26	25	24
Access								
Reset								
Bit	23	22	21	20	19	18	17	16
Access								
Reset								
Bit	15	14	13	12	11	10	9	8
	EXTINT[15:8]							
Access	R/W	R/W	R/W	R/W	R/W	R/W	R/W	R/W
Reset	0	0	0	0	0	0	0	0
Bit	7	6	5	4	3	2	1	0
	EXTINT[7:0]							
Access	R/W	R/W	R/W	R/W	R/W	R/W	R/W	R/W
Reset	0	0	0	0	0	0	0	0

#### Bits 15:0 – EXTINT[15:0] External Interrupt Enable

The bit x of EXTINT disables the interrupt associated with the EXTINTx pin.

Writing a '0' to bit x has no effect.

Writing a '1' to bit x will clear the External Interrupt Enable bit x, which disables the external interrupt EXTINTx.

Value	Description
0	The external interrupt x is disabled.
1	The external interrupt x is enabled.

### 23.8.7 Interrupt Enable Set

**Name:** INTENSET  
**Offset:** 0x10  
**Reset:** 0x00000000  
**Property:** PAC Write-Protection

This register allows the user to enable an interrupt without doing a read-modify-write operation. Changes in this register will also be reflected in the Interrupt Enable Clear (INTENCLR) register.

	Bit	31	30	29	28	27	26	25	24
Access									
Reset									
	Bit	23	22	21	20	19	18	17	16
Access									
Reset									
	Bit	15	14	13	12	11	10	9	8
		EXTINT[15:8]							
Access		R/W	R/W	R/W	R/W	R/W	R/W	R/W	R/W
Reset		0	0	0	0	0	0	0	0
	Bit	7	6	5	4	3	2	1	0
		EXTINT[7:0]							
Access		R/W	R/W	R/W	R/W	R/W	R/W	R/W	R/W
Reset		0	0	0	0	0	0	0	0

#### Bits 15:0 – EXTINT[15:0] External Interrupt Enable

The bit x of EXTINT enables the interrupt associated with the EXTINTx pin.

Writing a '0' to bit x has no effect.

Writing a '1' to bit x will set the External Interrupt Enable bit x, which enables the external interrupt EXTINTx.

Value	Description
0	The external interrupt x is disabled.
1	The external interrupt x is enabled.

### 23.8.8 Interrupt Flag Status and Clear

**Name:** INTFLAG  
**Offset:** 0x14  
**Reset:** 0x00000000  
**Property:** -

	31	30	29	28	27	26	25	24
Access								
Reset								
	23	22	21	20	19	18	17	16
Access								
Reset								
	15	14	13	12	11	10	9	8
	EXTINT[15:8]							
Access	R/W	R/W	R/W	R/W	R/W	R/W	R/W	R/W
Reset	0	0	0	0	0	0	0	0
	7	6	5	4	3	2	1	0
	EXTINT[7:0]							
Access	R/W	R/W	R/W	R/W	R/W	R/W	R/W	R/W
Reset	0	0	0	0	0	0	0	0

**Bits 15:0 – EXTINT[15:0] External Interrupt**

The flag bit x is cleared by writing a '1' to it.

This flag is set when EXTINTx pin matches the external interrupt sense configuration and will generate an interrupt request if [INTENCLR/SET](#).EXTINT[x] is '1'.

Writing a '0' to this bit has no effect.

Writing a '1' to this bit clears the External Interrupt x flag.

# SAM D5x/E5x Family Data Sheet

## EIC – External Interrupt Controller

### 23.8.9 External Interrupt Asynchronous Mode

**Name:** ASYNCH  
**Offset:** 0x18  
**Reset:** 0x00000000  
**Property:** PAC Write-Protection, Enable-Protected

	Bit	31	30	29	28	27	26	25	24										
		<table border="1" style="width: 100%; height: 15px; border-collapse: collapse;"> <tr> <td style="width: 12.5%;"></td> <td style="width: 12.5%;"></td> <td style="width: 12.5%;"></td> <td style="width: 12.5%;"></td> <td style="width: 12.5%;"></td> <td style="width: 12.5%;"></td> <td style="width: 12.5%;"></td> <td style="width: 12.5%;"></td> <td style="width: 12.5%;"></td> <td style="width: 12.5%;"></td> </tr> </table>																	
Access																			
Reset																			
	Bit	23	22	21	20	19	18	17	16										
		<table border="1" style="width: 100%; height: 15px; border-collapse: collapse;"> <tr> <td style="width: 12.5%;"></td> <td style="width: 12.5%;"></td> <td style="width: 12.5%;"></td> <td style="width: 12.5%;"></td> <td style="width: 12.5%;"></td> <td style="width: 12.5%;"></td> <td style="width: 12.5%;"></td> <td style="width: 12.5%;"></td> <td style="width: 12.5%;"></td> <td style="width: 12.5%;"></td> </tr> </table>																	
Access																			
Reset																			
	Bit	15	14	13	12	11	10	9	8										
		<table border="1" style="width: 100%; border-collapse: collapse;"> <tr> <td colspan="9" style="text-align: center;">ASYNCH[15:8]</td> </tr> </table>								ASYNCH[15:8]									
ASYNCH[15:8]																			
Access	RW	RW	RW	RW	RW	RW	RW	RW	RW										
Reset	0	0	0	0	0	0	0	0	0										
	Bit	7	6	5	4	3	2	1	0										
		<table border="1" style="width: 100%; border-collapse: collapse;"> <tr> <td colspan="9" style="text-align: center;">ASYNCH[7:0]</td> </tr> </table>								ASYNCH[7:0]									
ASYNCH[7:0]																			
Access	RW	RW	RW	RW	RW	RW	RW	RW	RW										
Reset	0	0	0	0	0	0	0	0	0										

**Bits 15:0 – ASYNCH[15:0] Asynchronous Edge Detection Mode**

The bit x of ASYNCH set the Asynchronous Edge Detection Mode for the interrupt associated with the EXTINTx pin.

Value	Description
0	The EXTINT x edge detection is synchronously operated.
1	The EXTINT x edge detection is asynchronously operated.

# SAM D5x/E5x Family Data Sheet

## EIC – External Interrupt Controller

### 23.8.10 External Interrupt Sense Configuration n

**Name:** CONFIG  
**Offset:** 0x1C + n\*0x04 [n=0..1]  
**Reset:** 0x00000000  
**Property:** PAC Write-Protection, Enable-Protected

Bit	31	30	29	28	27	26	25	24	
	FILTEN7		SENSE7[2:0]			FILTEN6		SENSE6[2:0]	
Access	RW	RW	RW	RW	RW	RW	RW	RW	
Reset	0	0	0	0	0	0	0	0	
Bit	23	22	21	20	19	18	17	16	
	FILTEN5		SENSE5[2:0]			FILTEN4		SENSE4[2:0]	
Access	RW	RW	RW	RW	RW	RW	RW	RW	
Reset	0	0	0	0	0	0	0	0	
Bit	15	14	13	12	11	10	9	8	
	FILTEN3		SENSE3[2:0]			FILTEN2		SENSE2[2:0]	
Access	RW	RW	RW	RW	RW	RW	RW	RW	
Reset	0	0	0	0	0	0	0	0	
Bit	7	6	5	4	3	2	1	0	
	FILTEN1		SENSE1[2:0]			FILTEN0		SENSE0[2:0]	
Access	RW	RW	RW	RW	RW	RW	RW	RW	
Reset	0	0	0	0	0	0	0	0	

**Bits 3, 7, 11, 15, 19, 23, 27, 31 – FILTENx** Filter Enable x [x=7..0]

**Note:** The filter must be disabled if the asynchronous detection is enabled.

Value	Description
0	Filter is disabled for EXTINT[n*8+x] input.
1	Filter is enabled for EXTINT[n*8+x] input.

**Bits 0:2, 4:6, 8:10, 12:14, 16:18, 20:22, 24:26, 28:30 – SENSEx** Input Sense Configuration x [x=7..0]

These bits define on which edge or level the interrupt or event for EXTINT[n\*8+x] will be generated.

Value	Name	Description
0x0	NONE	No detection
0x1	RISE	Rising-edge detection
0x2	FALL	Falling-edge detection
0x3	BOTH	Both-edge detection
0x4	HIGH	High-level detection
0x5	LOW	Low-level detection
0x6 – 0x7	-	Reserved



# SAM D5x/E5x Family Data Sheet

## EIC – External Interrupt Controller

### 23.8.11 Debouncer Enable

**Name:** DEBOUNCEN  
**Offset:** 0x30  
**Reset:** 0x00000000  
**Property:** PAC Write-Protection, Enable-Protected

Bit	31	30	29	28	27	26	25	24
Access								
Reset								
Bit	23	22	21	20	19	18	17	16
Access								
Reset								
Bit	15	14	13	12	11	10	9	8
Access	DEBOUNCEN[15:8]							
Reset	0	0	0	0	0	0	0	0
Bit	7	6	5	4	3	2	1	0
Access	DEBOUNCEN[7:0]							
Reset	0	0	0	0	0	0	0	0

#### Bits 15:0 – DEBOUNCEN[15:0] Debouncer Enable

The bit x of DEBOUNCEN set the Debounce mode for the interrupt associated with the EXTINTx pin.

Value	Description
0	The EXTINT x edge input is not debounced.
1	The EXTINT x edge input is debounced.

# SAM D5x/E5x Family Data Sheet

## EIC – External Interrupt Controller

### 23.8.12 Debouncer Prescaler

**Name:** DPRESCALER  
**Offset:** 0x34  
**Reset:** 0x00000000  
**Property:** PAC Write-Protection, Enable-Protected

Bit	31	30	29	28	27	26	25	24
Access								
Reset								
Bit	23	22	21	20	19	18	17	16
Access								TICKON
Reset								0
Bit	15	14	13	12	11	10	9	8
Access								
Reset								
Bit	7	6	5	4	3	2	1	0
Access	RW	RW	RW	RW	RW	RW	RW	RW
Reset	0	0	0	0	0	0	0	0

#### Bit 16 – TICKON Pin Sampler frequency selection

This bit selects the clock used for the sampling of bounce during transition detection.

Value	Description
0	The bounce sampler is using GCLK_EIC.
1	The bounce sampler is using the low frequency clock.

#### Bits 3, 7 – STATESx Debouncer number of states x

This bit selects the number of samples by the debouncer low frequency clock needed to validate a transition from current pin state to next pin state in synchronous debouncing mode for pins EXTINT[7+(8x):8x].

Value	Description
0	The number of low frequency samples is 3.
1	The number of low frequency samples is 7.

#### Bits 0:2, 4:6 – PRESCALERx Debouncer Prescaler x

These bits select the debouncer low frequency clock for pins EXTINT[7+(8x):8x].

Value	Name	Description
0x0	F/2	EIC clock divided by 2
0x1	F/4	EIC clock divided by 4
0x2	F/8	EIC clock divided by 8
0x3	F/16	EIC clock divided by 16

# SAM D5x/E5x Family Data Sheet

## EIC – External Interrupt Controller

Value	Name	Description
0x4	F/32	EIC clock divided by 32
0x5	F/64	EIC clock divided by 64
0x6	F/128	EIC clock divided by 128
0x7	F/256	EIC clock divided by 256

# SAM D5x/E5x Family Data Sheet

## EIC – External Interrupt Controller

### 23.8.13 Pin State

**Name:** PINSTATE  
**Offset:** 0x38  
**Reset:** 0x00000000

	Bit	31	30	29	28	27	26	25	24
		[Greyed out register]							
Access									
Reset									
	Bit	23	22	21	20	19	18	17	16
		[Greyed out register]							
Access									
Reset									
	Bit	15	14	13	12	11	10	9	8
		PINSTATE[15:8]							
Access		R	R	R	R	R	R	R	R
Reset		0	0	0	0	0	0	0	0
	Bit	7	6	5	4	3	2	1	0
		PINSTATE[7:0]							
Access		R	R	R	R	R	R	R	R
Reset		0	0	0	0	0	0	0	0

**Bits 15:0 – PINSTATE[15:0] Pin State**

These bits return the valid pin state of the debounced external interrupt pin EXTINTx.

## 24. GMAC - Ethernet MAC

The description and registers of this peripheral are using the 'GMAC' designation although the device does not support Gigabit Ethernet functionality.

### 24.1 Description

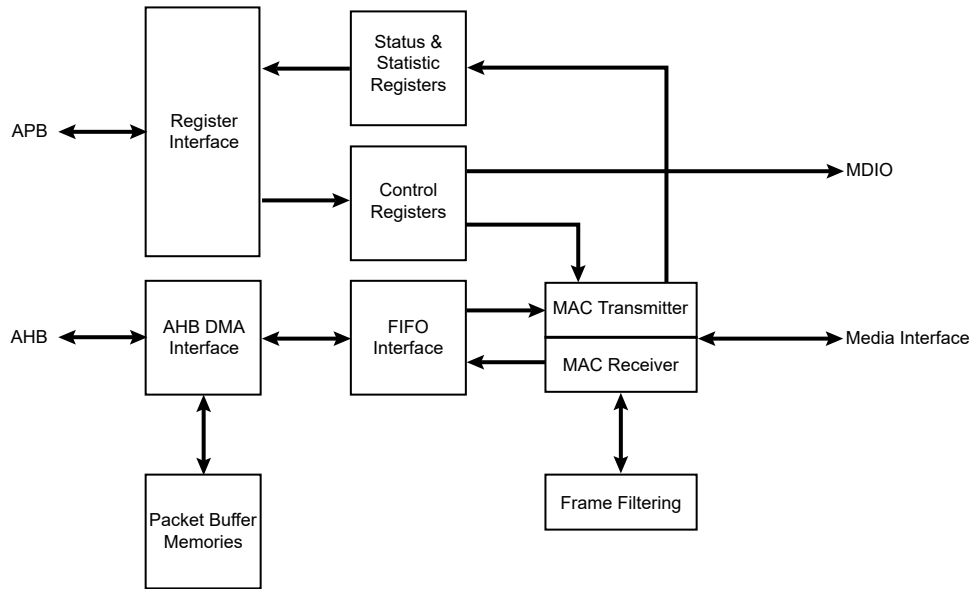
The Ethernet Media Access Controller (GMAC) module implements a 10/100 Mbps Ethernet MAC, compatible with the IEEE 802.3 standard. The GMAC can operate in either half or full duplex mode at all supported speeds.

### 24.2 Features

- Compatible with IEEE Standard 802.3
- 10, 100 Mbps operation
- Full and half duplex operation at all supported speeds of operation
- Statistics Counter Registers for RMON/MIB
- MII/RMII interface to the physical layer
- Integrated physical coding
- Direct memory access (DMA) interface to external memory
- Programmable burst length and endianism for DMA
- Interrupt generation to signal receive and transmit completion, errors or other events
- Automatic pad and cyclic redundancy check (CRC) generation on transmitted frames
- Automatic discard of frames received with errors
- Receive and transmit IP, TCP and UDP checksum offload. Both IPv4 and IPv6 packet types supported
- Address checking logic for four specific 48-bit addresses, four type IDs, promiscuous mode, hash matching of unicast and multicast destination addresses and Wake-on-LAN
- Management Data Input/Output (MDIO) interface for physical layer management
- Support for jumbo frames up to 10240 Bytes
- Full duplex flow control with recognition of incoming pause frames and hardware generation of transmitted pause frames
- Half duplex flow control by forcing collisions on incoming frames
- Support for 802.1Q VLAN tagging with recognition of incoming VLAN and priority tagged frames
- Programmable Inter Packet Gap (IPG) Stretch
- Recognition of IEEE 1588 PTP frames
- IEEE 1588 time stamp unit (TSU) and TSU event generation
- Support for 802.1AS timing and synchronization
- Supports 802.1Qav traffic shaping on two highest priority queues
- Support for 802.3az Energy Efficient Ethernet

### 24.3 Block Diagram

Figure 24-1. Block Diagram



### 24.4 Signal Description

The GMAC includes the following signal interfaces:

- MII, RMI to an external PHY
- MDIO interface for external PHY management
- Slave APB interface for accessing GMAC registers
- Master AHB interface for memory access
- GTSUCOMP signal for TSU timer count value comparison

Table 24-1. GMAC Connections in Different Modes

Signal Name	Function	MII	RMI
GTXCK	Transmit Clock or Reference Clock	TXCK	REFCK
GTXEN	Transmit Enable	TXEN	TXEN
GTX[3..0]	Transmit Data	TXD[3:0]	TXD[1:0]
GTXER	Transmit Coding Error	TXER	Not Used
GRXCK	Receive Clock	RXCK	Not Used
GRXDV	Receive Data Valid	RXDV	CRSDV
GRX[3..0]	Receive Data	RXD[3:0]	RXD[1:0]
GRXER	Receive Error	RXER	RXER
GCRS	Carrier Sense and Data Valid	CRS	Not Used
GCOL	Collision Detect	COL	Not Used

.....continued			
Signal Name	Function	MII	RMII
GMDC	Management Data Clock	MDC	MDC
GMDIO	Management Data Input/Output	MDIO	MDIO

•

## 24.5 Product Dependencies

### 24.5.1 I/O Lines

Using the GMAC I/O lines requires the I/O pins to be configured using the port configuration (PORT).

#### Related Links

- [6. I/O Multiplexing and Considerations](#)
- [32. PORT - I/O Pin Controller](#)

### 24.5.2 Power Management

The GMAC continues to operate in IDLE and Standby sleep modes if REF\_CLK or GRXCK is running.

All GMAC interrupts can be used to wake up the device from IDLE sleep mode.

In Standby sleep mode, only the WOL interrupt can wake up the CPU, and the corresponding ISR flags will not be set.

#### Related Links

- [18. PM – Power Manager](#)

### 24.5.3 Clocks

The GMAC peripheral relies on a system clock from the Main Clock Controller (MCLK) for register access and GMAC MCK.

In MII mode, the actual Transmit or Reference Clock (GTXCK) and Receive Clock (GRXCK) are external signals.

In RMII mode, the actual Reference Clock (REF\_CLK) are external signals.

The respective pins are configured in the PORT peripheral.

#### Related Links

- [6. I/O Multiplexing and Considerations](#)
- [32. PORT - I/O Pin Controller](#)

### 24.5.4 Interrupt Sources

The GMAC interrupt line is connected to the interrupt controller. Using the GMAC interrupt requires to configure the interrupt controller first.

#### Related Links

- [10.2 Nested Vector Interrupt Controller](#)

### 24.5.5 Events

The event GMAC Timestamp Comparison is connected to the Event System.

#### Related Links

### 31. EVSYS – Event System

## 24.6 Functional Description

### 24.6.1 Media Access Controller

The Transmit Block of the Media Access Controller (MAC) takes data from FIFO, adds preamble, checks and adds padding and frame check sequence (FCS). Both half duplex and full duplex Ethernet modes of operation are supported.

When operating in half duplex mode, the MAC Transmit Block generates data according to the Carrier Sense Multiple Access with Collision Detect (CSMA/CD) protocol. The start of transmission is deferred if Carrier Sense (CRS) is active. If Collision (COL) is detected during transmission, a jam sequence is asserted and the transmission is retried after a random back off. The CRS and COL signals have no effect in full duplex mode.

The Receive Block of the MAC checks for valid preamble, FCS, alignment and length, and presents received frames to the MAC address checking block and FIFO. Software can configure the GMAC to receive jumbo frames of up to 10240 Bytes. It can optionally strip CRC (Cyclic Redundancy Check) from the received frame before transferring it to FIFO.

The Address Checker recognizes four specific 48-bit addresses, can recognize four different types of ID values, and contains a 64-bit Hash register for matching multicast and unicast addresses as required. It can recognize the broadcast address *all-'1'* (0xFFFFFFFFFFFF) and copy all frames. The MAC can also reject all frames that are not VLAN tagged, and recognize Wake on LAN events.

The MAC Receive Block supports offloading of IP, TCP and UDP checksum calculations (both IPv4 and IPv6 packet types supported), and can automatically discard bad checksum frames.

### 24.6.2 IEEE 1588 Time Stamp Unit

The IEEE 1588 time stamp unit (TSU) is implemented as a 94-bit timer.

- The 48 upper bits [93:46] of the timer count seconds and are accessible in the GMAC 1588 Timer Seconds High Register” (TSH) and GMAC 1588 Timer Seconds Low Register (TSL).
- The 30 lower bits [45:16] of the timer count nanoseconds and are accessible in the GMAC 1588 Timer Nanoseconds Register (TN).
- The lowest 16 bits [15:0] of the timer count sub-nanoseconds.

The 46 lower bits roll over when they have counted to 1s. The timer increments by a programmable period (to approximately 15.2fs resolution) with each MCK period and can also be adjusted in 1ns resolution (incremented or decremented) through APB register accesses.

### 24.6.3 AHB Direct Memory Access Interface

The GMAC DMA controller is connected to the MAC FIFO interface and provides a scatter-gather type capability for packet data storage.

The DMA implements packet buffering where dual-port memories are used to buffer multiple frames.

#### 24.6.3.1 Packet Buffer DMA

- Easier to guarantee maximum line rate due to the ability to store multiple frames in the packet buffer, where the number of frames is limited by the amount of packet buffer memory and Ethernet frame size
- Full store and forward, or partial store and forward programmable options (partial store will cater for shorter latency requirements)



- Support for Transmit TCP/IP checksum offload
- Support for priority queuing
- When a collision on the line occurs during transmission, the packet will be automatically replayed directly from the packet buffer memory rather than having to re-fetch through the AHB (full store and forward ONLY)
- Received erroneous packets are automatically dropped before any of the packet is presented to the AHB (full store and forward ONLY), thus reducing AHB activity
- Supports manual RX packet flush capabilities
- Optional RX packet flush when there is lack of AHB resource

### 24.6.3.2 Partial Store and Forward Using Packet Buffer DMA

The DMA uses SRAM-based packet buffers, and can be programmed into a low latency mode, known as Partial Store and Forward. This mode allows for a reduced latency as the full packet is not buffered before forwarding.

**Note:** This option is only available when the device is configured for full duplex operation.

This feature is enabled via the programmable TX and RX Partial Store and Forward registers (TPSF and RPSF). When the transmit Partial Store and Forward mode is activated, the transmitter will only begin to forward the packet to the MAC when there is enough packet data stored in the packet buffer. Likewise, when the receive Partial Store and Forward mode is activated, the receiver will only begin to forward the packet to the AHB when enough packet data is stored in the packet buffer. The amount of packet data required to activate the forwarding process is programmable via watermark registers. These registers are located at the same address as the partial store and forward enable bits.

**Note:** The minimum operational value for the TX partial store and forward watermark is 20. There is no operational limit for the RX partial store and forward watermark.

Enabling Partial Store and Forward is a useful means to reduce latency, but there are performance implications. The GMAC DMA uses separate transmit and receive lists of buffer descriptors, with each descriptor describing a buffer area in memory. This allows Ethernet packets to be broken up and scattered around the AHB memory space.

### 24.6.3.3 Receive AHB Buffers

Received frames, optionally including FCS, are written to receive AHB buffers stored in memory. The receive buffer depth is programmable in the range of 64 Bytes to 16 KBytes through the DMA Configuration register (DCFGR), with the default being 128 Bytes.

The start location for each receive AHB buffer is stored in memory in a list of receive buffer descriptors at an address location pointed to by the receive buffer queue pointer. The base address for the receive buffer queue pointer is configured in software using the Receive Buffer Queue Base Address register (RBQB).

Each list entry consists of two words. The first is the address of the receive AHB buffer and the second the receive status.

If the length of a receive frame exceeds the AHB buffer length, the status word for the used buffer is written with zeroes except for the "Start of Frame" bit, which is always set for the first buffer in a frame.

Bit zero of the address field is written to 1 to show that the buffer has been used. The receive buffer manager then reads the location of the next receive AHB buffer and fills that with the next part of the received frame data. AHB buffers are filled until the frame is complete and the final buffer descriptor status word contains the complete frame status. See the following table for details of the receive buffer descriptor list.

**Table 24-2. Receive Buffer Descriptor Entry**

Bit	Function
Word 0	
31:2	Address of beginning of buffer
1	Wrap—marks last descriptor in receive buffer descriptor list.
0	Ownership—needs to be zero for the GMAC to write data to the receive buffer. The GMAC sets this to one once it has successfully written a frame to memory. Software has to clear this bit before the buffer can be used again.
Word 1	
31	Global all ones broadcast address detected
30	Multicast hash match
29	Unicast hash match
28	–
27	Specific Address Register match found, bit 25 and bit 26 indicate which Specific Address Register causes the match.
26:25	Specific Address Register match. Encoded as follows: 00: Specific Address Register 1 match 01: Specific Address Register 2 match 10: Specific Address Register 3 match 11: Specific Address Register 4 match If more than one specific address is matched only one is indicated with priority 4 down to 1.
24	This bit has a different meaning depending on whether RX checksum offloading is enabled. With RX checksum offloading disabled: (bit 24 clear in Network Configuration Register) Type ID register match found, bit 22 and bit 23 indicate which type ID register causes the match. With RX checksum offloading enabled: (bit 24 set in Network Configuration Register) 0: The frame was not SNAP encoded and/or had a VLAN tag with the Canonical Format Indicator (CFI) bit set. 1: The frame was SNAP encoded and had either no VLAN tag or a VLAN tag with the CFI bit not set.

# SAM D5x/E5x Family Data Sheet

## GMAC - Ethernet MAC

.....continued

Bit	Function
23:22	<p>This bit has a different meaning depending on whether RX checksum offloading is enabled.</p> <p>With RX checksum offloading disabled: (bit 24 clear in Network Configuration)</p> <p>Type ID register match. Encoded as follows:</p> <p>00: Type ID register 1 match</p> <p>01: Type ID register 2 match</p> <p>10: Type ID register 3 match</p> <p>11: Type ID register 4 match</p> <p>If more than one Type ID is matched only one is indicated with priority 4 down to 1.</p> <p>With RX checksum offloading enabled: (bit 24 set in Network Configuration Register)</p> <p>00: Neither the IP header checksum nor the TCP/UDP checksum was checked.</p> <p>01: The IP header checksum was checked and was correct. Neither the TCP nor UDP checksum was checked.</p> <p>10: Both the IP header and TCP checksum were checked and were correct.</p> <p>11: Both the IP header and UDP checksum were checked and were correct.</p>
21	VLAN tag detected—type ID of 0x8100. For packets incorporating the stacked VLAN processing feature, this bit will be set if the second VLAN tag has a type ID of 0x8100
20	Priority tag detected—type ID of 0x8100 and null VLAN identifier. For packets incorporating the stacked VLAN processing feature, this bit will be set if the second VLAN tag has a type ID of 0x8100 and a null VLAN identifier.
19:17	VLAN priority—only valid if bit 21 is set.
16	Canonical format indicator (CFI) bit (only valid if bit 21 is set).
15	End of frame—when set the buffer contains the end of a frame. If end of frame is not set, then the only valid status bit is start of frame (bit 14).
14	Start of frame—when set the buffer contains the start of a frame. If both bits 15 and 14 are set, the buffer contains a whole frame.
13	<p>This bit has a different meaning depending on whether jumbo frames and ignore FCS modes are enabled. If neither mode is enabled this bit will be zero.</p> <p>With jumbo frame mode enabled: (bit 3 set in Network Configuration Register) Additional bit for length of frame (bit[13]), that is concatenated with bits[12:0]</p> <p>With ignore FCS mode enabled and jumbo frames disabled: (bit 26 set in Network Configuration Register and bit 3 clear in Network Configuration Register) This indicates per frame FCS status as follows:</p> <p>0: Frame had good FCS</p> <p>1: Frame had bad FCS, but was copied to memory as ignore FCS enabled.</p>

.....continued

Bit	Function
12:0	<p>These bits represent the length of the received frame which may or may not include FCS depending on whether FCS discard mode is enabled.</p> <p>With FCS discard mode disabled: (bit 17 clear in Network Configuration Register)</p> <p>Least significant 12 bits for length of frame including FCS. If jumbo frames are enabled, these 12 bits are concatenated with bit[13] of the descriptor above.</p> <p>With FCS discard mode enabled: (bit 17 set in Network Configuration Register)</p> <p>Least significant 12 bits for length of frame excluding FCS. If jumbo frames are enabled, these 12 bits are concatenated with bit[13] of the descriptor above.</p>

Each receive AHB buffer start location is a word address. The start of the first AHB buffer in a frame can be offset by up to three Bytes, depending on the value written to bits 14 and 15 of the Network Configuration register (NCFGR). If the start location of the AHB buffer is offset, the available length of the first AHB buffer is reduced by the corresponding number of Bytes.

To receive frames, the AHB buffer descriptors must be initialized by writing an appropriate address to bits 31:2 in the first word of each list entry. Bit 0 must be written with zero. Bit 1 is the wrap bit and indicates the last entry in the buffer descriptor list.

The start location of the receive buffer descriptor list must be written with the receive buffer queue base address before reception is enabled (receive enable in the Network Control register NCR). Once reception is enabled, any writes to the Receive Buffer Queue Base Address register (RBQB) are ignored. When read, it will return the current pointer position in the descriptor list, though this is only valid and stable when receive is disabled.

If the filter block indicates that a frame should be copied to memory, the receive data DMA operation starts writing data into the receive buffer. If an error occurs, the buffer is recovered.

An internal counter within the GMAC represents the receive buffer queue pointer and it is not visible through the CPU interface. The receive buffer queue pointer increments by two words after each buffer has been used. It re-initializes to the receive buffer queue base address if any descriptor has its wrap bit set.

As receive AHB buffers are used, the receive AHB buffer manager sets bit zero of the first word of the descriptor to logic one indicating the AHB buffer has been used.

Software should search through the “used” bits in the AHB buffer descriptors to find out how many frames have been received, checking the start of frame and end of frame bits.

When the DMA is configured in the packet buffer Partial Store And Forward mode, received frames are written out to the AHB buffers as soon as enough frame data exists in the packet buffer. For both cases, this may mean several full AHB buffers are used before some error conditions can be detected. If a receive error is detected the receive buffer currently being written will be recovered. Previous buffers will not be recovered. As an example, when receiving frames with cyclic redundancy check (CRC) errors or excessive length, it is possible that a frame fragment might be stored in a sequence of AHB receive buffers. Software can detect this by looking for start of frame bit set in a buffer following a buffer with no end of frame bit set.

To function properly, a 10/100 Ethernet system should have no excessive length frames or frames greater than 128 Bytes with CRC errors. Collision fragments will be less than 128 Bytes long, therefore it will be a

rare occurrence to find a frame fragment in a receive AHB buffer, when using the default value of 128 Bytes for the receive buffers size.

When in packet buffer full store and forward mode, only good received frames are written out of the DMA, so no fragments will exist in the AHB buffers due to MAC receiver errors. There is still the possibility of fragments due to DMA errors, for example used bit read on the second buffer of a multi-buffer frame.

If bit zero of the receive buffer descriptor is already set when the receive buffer manager reads the location of the receive AHB buffer, the buffer has been already used and cannot be used again until software has processed the frame and cleared bit zero. In this case, the “buffer not available” bit in the receive status register is set and an interrupt triggered. The receive resource error statistics register is also incremented.

When the DMA is configured in the packet buffer full store and forward mode, the user can optionally select whether received frames should be automatically discarded when no AHB buffer resource is available. This feature is selected via the DMA Discard Receive Packets bit in the DMA Configuration register (DCFGR.DDRP). By default, the received frames are not automatically discarded. If this feature is off, then received packets will remain to be stored in the SRAM-based packet buffer until AHB buffer resource next becomes available. This may lead to an eventual packet buffer overflow if packets continue to be received when bit zero (used bit) of the receive buffer descriptor remains set.

**Note:** After a used bit has been read, the receive buffer manager will re-read the location of the receive buffer descriptor every time a new packet is received. When the DMA is not configured in the packet buffer full store and forward mode and a used bit is read, the frame currently being received will be automatically discarded.

When the DMA is configured in the packet buffer full store and forward mode, a receive overrun condition occurs when the receive SRAM-based packet buffer is full, or because HRESP was not OK. In all other modes, a receive overrun condition occurs when either the AHB bus was not granted quickly enough, or because HRESP was not OK, or because a new frame has been detected by the receive block, but the status update or write back for the previous frame has not yet finished. For a receive overrun condition, the receive overrun interrupt is asserted and the buffer currently being written is recovered. The next frame that is received whose address is recognized reuses the buffer.

In any packet buffer mode, writing a '1' to the Flush Next Package bit in the NCR register (NCR.FNP) will force a packet from the external SRAM-based receive packet buffer to be flushed. This feature is only acted upon when the RX DMA is not currently writing packet data out to AHB, i.e., it is in an IDLE state. If the RX DMA is active, NCR.FNP=1 is ignored.

#### 24.6.3.4 Transmit AHB Buffers

Frames to transmit are stored in one or more transmit AHB buffers. Transmit frames can be between 1 and 16384 Bytes long, so it is possible to transmit frames longer than the maximum length specified in the IEEE 802.3 standard. It should be noted that zero length AHB buffers are allowed and that the maximum number of buffers permitted for each transmit frame is 128.

The start location for each transmit AHB buffer is stored in memory in a list of transmit buffer descriptors at a location pointed to by the transmit buffer queue pointer. The base address for this queue pointer is set in software using the Transmit Buffer Queue Base Address register. Each list entry consists of two words. The first is the Byte address of the transmit buffer and the second containing the transmit control and status. For the packet buffer DMA, the start location for each AHB buffer is a Byte address, the bottom bits of the address being used to offset the start of the data from the data-word boundary (i.e., bits 2,1 and 0 are used to offset the address for 64-bit data paths).

Frames can be transmitted with or without automatic Cyclic Redundancy Checksum (CRC) generation. If CRC is automatically generated, pad will also be automatically generated to take frames to a minimum

# SAM D5x/E5x Family Data Sheet

## GMAC - Ethernet MAC

length of 64 Bytes. When CRC is not automatically generated (as defined in word 1 of the transmit buffer descriptor), the frame is assumed to be at least 64 Bytes long and pad is not generated.

An entry in the transmit buffer descriptor list is described in this table:

**Table 24-3. Transmit Buffer Descriptor Entry**

Bit	Function
Word 0	
31:0	Byte address of buffer
Word 1	
31	Used—must be zero for the GMAC to read data to the transmit buffer. The GMAC sets this to one for the first buffer of a frame once it has been successfully transmitted. Software must clear this bit before the buffer can be used again.
30	Wrap—marks last descriptor in transmit buffer descriptor list. This can be set for any buffer within the frame.
29	Retry limit exceeded, transmit error detected
28	Reserved.
27	Transmit frame corruption due to AHB error—set if an error occurs while midway through reading transmit frame from the AHB, including HRESP errors and buffers exhausted mid frame (if the buffers run out during transmission of a frame then transmission stops, FCS shall be bad and GTXER asserted). Also set if single frame is too large for configured packet buffer memory size.
26	Late collision, transmit error detected.
25:23	Reserved
22:20	Transmit IP/TCP/UDP checksum generation offload errors: 000: No Error.  001: The Packet was identified as a VLAN type, but the header was not fully complete, or had an error in it.  010: The Packet was identified as a SNAP type, but the header was not fully complete, or had an error in it.  011: The Packet was not of an IP type, or the IP packet was invalidly short, or the IP was not of type IPv4/IPv6.  100: The Packet was not identified as VLAN, SNAP or IP.  101: Non supported packet fragmentation occurred. For IPv4 packets, the IP checksum was generated and inserted.  110: Packet type detected was not TCP or UDP. TCP/UDP checksum was therefore not generated. For IPv4 packets, the IP checksum was generated and inserted.  111: A premature end of packet was detected and the TCP/UDP checksum could not be generated.
19:17	Reserved

# SAM D5x/E5x Family Data Sheet

## GMAC - Ethernet MAC

.....continued	
Bit	Function
16	<p>No CRC to be appended by MAC. When set, this implies that the data in the buffers already contains a valid CRC, hence no CRC or padding is to be appended to the current frame by the MAC.</p> <p>This control bit must be set for the first buffer in a frame and will be ignored for the subsequent buffers of a frame.</p> <p>Note that this bit must be clear when using the transmit IP/TCP/UDP checksum generation offload, otherwise checksum generation and substitution will not occur.</p>
15	Last buffer, when set this bit will indicate the last buffer in the current frame has been reached.
14	Reserved
13:0	Length of buffer

To transmit frames, the buffer descriptors must be initialized by writing an appropriate Byte address to bits [31:0] of the first word of each descriptor list entry.

The second word of the transmit buffer descriptor is initialized with control information that indicates the length of the frame, whether or not the MAC is to append CRC and whether the buffer is the last buffer in the frame.

After transmission the status bits are written back to the second word of the first buffer along with the used bit. Bit 31 is the used bit which must be zero when the control word is read if transmission is to take place. It is written to '1' once the frame has been transmitted. Bits[29:20] indicate various transmit error conditions. Bit 30 is the wrap bit which can be set for any buffer within a frame. If no wrap bit is encountered the queue pointer continues to increment.

The Transmit Buffer Queue Base Address register can only be updated while transmission is disabled or halted; otherwise any attempted write will be ignored. When transmission is halted the transmit buffer queue pointer will maintain its value. Therefore when transmission is restarted the next descriptor read from the queue will be from immediately after the last successfully transmitted frame. As long as transmit is disabled by writing a '0' to the Transmit Enable bit in the Network Control register (NCR.TXEN), the transmit buffer queue pointer resets to point to the address indicated by the Transmit Buffer Queue Base Address register (TBQB).

**Note:** Disabling receive does not have the same effect on the receive buffer queue pointer.

Once the transmit queue is initialized, transmit is activated by writing a '1' to the Start Transmission bit of the Network Control register (NCR.TSTART). Transmit is halted when a buffer descriptor with its used bit set is read, a transmit error occurs, or by writing to the Transmit Halt bit of the Network Control register (NCR.THALT). Transmission is suspended if a pause frame is received while the Transmit Pause Frame bit is '1' in the Network Configuration register (NCR.TXPF). Rewriting the Start bit (NCR.TSTART) while transmission is active is allowed. This is implemented by the Transmit Go variable which is readable in the Transmit Status register (TSR.TXGO). The TXGO variable is reset when:

- Transmit is disabled.
- A buffer descriptor with its ownership bit set is read.
- Bit 10, THALT, of the Network Control register is written.
- There is a transmit error such as too many retries or a transmit underrun.

To set TXGO, write a '1' to NCR.TSTART. Transmit halt does not take effect until any ongoing transmit finishes.

If the DMA is configured for packet buffer Partial Store and Forward mode and a collision occurs during transmission of a multi-buffer frame, transmission will automatically restart from the first buffer of the frame. For packet buffer mode, the entire contents of the frame are read into the transmit packet buffer memory, so the retry attempt will be replayed directly from the packet buffer memory rather than having to re-fetch through the AHB.

If a used bit is read midway through transmission of a multi-buffer frame, this is treated as a transmit error. Transmission stops, GTXER is asserted and the FCS will be bad.

If transmission stops due to a transmit error or a used bit being read, transmission restarts from the first buffer descriptor of the frame being transmitted when the transmit start bit is rewritten.

### 24.6.3.5 DMA Bursting on the AHB

The DMA will always use SINGLE, or INCR type AHB accesses for buffer management operations. When performing data transfers, the AHB burst length is selected by the Fixed Burst Length for DMA Data Operations bit field in the DMA Configuration register (DCFGR.FBLDO) so that either SINGLE or fixed length incrementing bursts (INCR4, INCR8 or INCR16) are used where possible:

When there is enough space and enough data to be transferred, the programmed fixed length bursts will be used. If there is not enough data or space available, for example when at the beginning or the end of a buffer, SINGLE type accesses are used. Also SINGLE type accesses are used at 1024 Byte boundaries, so that the 1 KByte boundaries are not burst over as per AHB requirements.

The DMA will not terminate a fixed length burst early, unless an error condition occurs on the AHB or if receive or transmit are disabled in the Network Control register (NCR).

### 24.6.3.6 DMA Packet Buffer

The DMA uses packet buffers for both transmit and receive paths. This mode allows multiple packets to be buffered in both transmit and receive directions. This allows the DMA to withstand far greater access latencies on the AHB and make more efficient use of the AHB bandwidth. There are two modes of operation—Full Store and Forward and Partial Store and Forward.

As described above, the DMA can be programmed into a low latency mode, known as Partial Store and Forward. For further details of this mode, see the related Links.

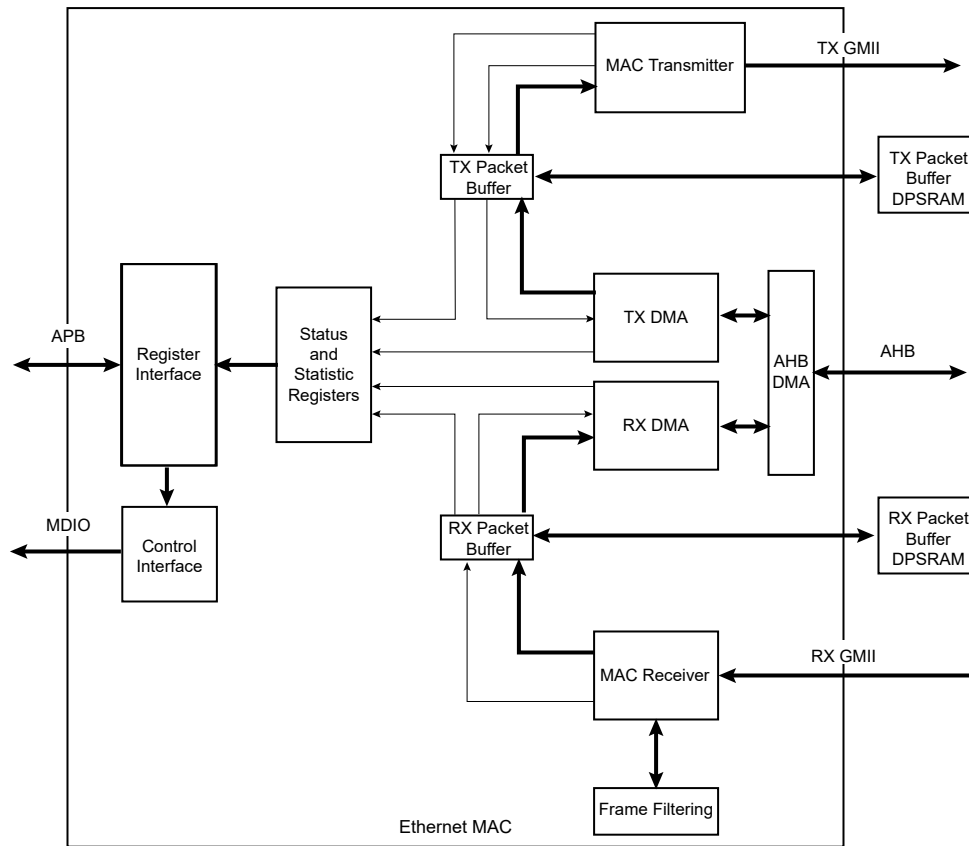
When the DMA is in full store and forward mode, full packets are buffered which provides the possibility to:

- Discard packets with error on the receive path before they are partially written out of the DMA, thus saving AHB bus bandwidth and driver processing overhead,
- Retry collided transmit frames from the buffer, thus saving AHB bus bandwidth,
- Implement transmit IP/TCP/UDP checksum generation offload.

With the packet buffers included, the structure of the GMAC data paths is shown in this image:



**Figure 24-2. Data Paths with Packet Buffers Included**



### 24.6.3.7 Transmit Packet Buffer

The transmitter packet buffer will continue attempting to fetch frame data from the AHB system memory until the packet buffer itself is full, at which point it will attempt to maintain its full level.

To accommodate the status and statistics associated with each frame, three words per packet (or two if the GMAC is configured in 64-bit data path mode) are reserved at the end of the packet data. If the packet is bad and requires to be dropped, the status and statistics are the only information held on that packet. Storing the status in the DPRAM is required in order to decouple the DMA interface of the buffer from the MAC interface, to update the MAC status/statistics and to generate interrupts in the order in which the packets that they represent were fetched from the AHB memory.

If any errors occur on the AHB while reading the transmit frame, the fetching of packet data from AHB memory is halted. The MAC transmitter will continue to fetch packet data, thereby emptying the packet buffer and allowing any good (non-erroneous) frames to be transmitted successfully. Once these have been fully transmitted, the status/statistics for the erroneous frame will be updated and software will be informed via an interrupt that an AHB error occurred. This way, the error is reported in the correct packet order.

The transmit packet buffer will only attempt to read more frame data from the AHB when space is available in the packet buffer memory. If space is not available it must wait until the a packet fetched by the MAC completes transmission and is subsequently removed from the packet buffer memory.

**Note:** If full store and forward mode is active and if a single frame is fetched that is too large for the packet buffer memory, the frame is flushed and the DMA halted with an error status. This is because a complete frame must be written into the packet buffer before transmission can begin, and therefore the minimum packet buffer memory size should be chosen to satisfy the maximum frame to be transmitted in the application.

In full store and forward mode, once the complete transmit frame is written into the packet buffer memory, a trigger is sent across to the MAC transmitter, which will then begin reading the frame from the packet buffer memory. Since the whole frame is present and stable in the packet buffer memory an underflow of the transmitter is not possible. The frame is kept in the packet buffer until notification is received from the MAC that the frame data has either been successfully transmitted or can no longer be retransmitted (too many retries in half duplex mode). When this notification is received the frame is flushed from memory to make room for a new frame to be fetched from AHB system memory.

In Partial Store and Forward mode, a trigger is sent across to the MAC transmitter as soon as sufficient packet data is available, which will then begin fetching the frame from the packet buffer memory. If, after this point, the MAC transmitter is able to fetch data from the packet buffer faster than the AHB DMA can fill it, an underflow of the transmitter is possible. In this case, the transmission is terminated early, and the packet buffer is completely flushed. Transmission can only be restarted by writing a '1' to the Transmit Start bit in the Network Control register (NCR.TSTART).

In half duplex mode, the frame is kept in the packet buffer until notification is received from the MAC that the frame data has either been successfully transmitted or can no longer be retransmitted (too many retries in half duplex mode). When this notification is received the frame is flushed from memory to make room for a new frame to be fetched from AHB system memory.

In full duplex mode, the frame is removed from the packet buffer on the fly.

Other than underflow, the only MAC related errors that can occur are due to collisions during half duplex transmissions. When a collision occurs the frame still exists in the packet buffer memory so can be retried directly from there. After sixteen failed transmit attempts, the frame will be flushed from the packet buffer.

### 24.6.3.8 Receive Packet Buffer

The receive packet buffer stores frames from the MAC receiver along with their status and statistics. Frames with errors are flushed from the packet buffer memory, while good frames are pushed onto the DMA AHB interface.

The receiver packet buffer monitors the FIFO write interface from the MAC receiver and translates the FIFO pushes into packet buffer writes. At the end of the received frame the status and statistics are buffered so that the information can be used when the frame is read out. When programmed in full store and forward mode and the frame has an error, the frame data is immediately flushed from the packet buffer memory allowing subsequent frames to utilize the freed up space. The status and statistics for bad frames are still used to update the GMAC registers.

To accommodate the status and statistics associated with each frame, three words per packet (or two if configured in 64-bit datapath mode) are reserved at the end of the packet data. If the packet is bad and requires to be dropped, the status and statistics are the only information held on that packet.

The receiver packet buffer will also detect a full condition so that an overflow condition can be detected. If this occurs, subsequent packets are dropped and an RX overflow interrupt is raised.

For full store and forward, the DMA only begins packet fetches once the status and statistics for a frame are available. If the frame has a bad status due to a frame error, the status and statistics are passed on to the GMAC registers. If the frame has a good status, the information is used to read the frame from the packet buffer memory and burst onto the AHB using the DMA buffer management protocol. Once the last

frame data has been transferred to the packet buffer, the status and statistics are updated to the GMAC registers.

If Partial Store and Forward mode is active, the DMA will begin fetching the packet data before the status is available. As soon as the status becomes available, the DMA will fetch this information as soon as possible before continuing to fetch the remainder of the frame. Once the last frame data has been transferred to the packet buffer, the status and statistics are updated to the GMAC registers.

#### 24.6.4 MAC Transmit Block

The MAC transmitter can operate in either half duplex or full duplex mode and transmits frames in accordance with the Ethernet IEEE 802.3 standard. In half duplex mode, the CSMA/CD protocol of the IEEE 802.3 specification is followed.

A small input buffer receives data through the FIFO interface which will extract data in 32-bit form. All subsequent processing prior to the final output is performed in bytes.

Transmit data can be output using the MII interface.

Frame assembly starts by adding preamble and the start frame delimiter. Data is taken from the transmit FIFO interface a word at a time.

If necessary, padding is added to take the frame length to 60 bytes. CRC is calculated using an order 32-bit polynomial. This is inverted and appended to the end of the frame taking the frame length to a minimum of 64 bytes. If the no CRC bit is set in the second word of the last buffer descriptor of a transmit frame, neither pad nor CRC are appended. The no CRC bit can also be set through the FIFO interface.

In full duplex mode (at all data rates), frames are transmitted immediately. Back to back frames are transmitted at least 96 bit times apart to guarantee the interframe gap.

In half duplex mode, the transmitter checks carrier sense. If asserted, the transmitter waits for the signal to become inactive, and then starts transmission after the interframe gap of 96 bit times. If the collision signal is asserted during transmission, the transmitter will transmit a jam sequence of 32 bits taken from the data register and then retry transmission after the back off time has elapsed. If the collision occurs during either the preamble or Start Frame Delimiter (SFD), then these fields will be completed prior to generation of the jam sequence.

The back off time is based on an XOR of the 10 least significant bits of the data coming from the transmit FIFO interface and a 10-bit pseudo random number generator. The number of bits used depends on the number of collisions seen. After the first collision 1 bit is used, then the second 2 bits and so on up to the maximum of 10 bits. All 10 bits are used above ten collisions. An error will be indicated and no further attempts will be made if 16 consecutive attempts cause collision. This operation is compliant with the description in Clause 4.2.3.2.5 of the IEEE 802.3 standard which refers to the truncated binary exponential back off algorithm.

In 10/100 mode, both collisions and late collisions are treated identically, and back off and retry will be performed up to 16 times. This condition is reported in the transmit buffer descriptor word 1 (late collision, bit 26) and also in the Transmit Status register (late collision, bit 7). An interrupt can also be generated (if enabled) when this exception occurs, and bit 5 in the Interrupt Status register will be set.

In all modes of operation, if the transmit DMA underruns, a bad CRC is automatically appended using the same mechanism as jam insertion and the GTXER signal is asserted. For a properly configured system this should never happen and also it is impossible if configured to use the DMA with packet buffers, as the complete frame is buffered in local packet buffer memory.

By setting when bit 28 is set in the Network Configuration register, the Inter Packet Gap (IPG) may be stretched beyond 96 bits depending on the length of the previously transmitted frame and the value written to the IPG Stretch register (IPGS). The least significant 8 bits of the IPG Stretch register multiply the previous frame length (including preamble). The next significant 8 bits (+1 so as not to get a divide by zero) divide the frame length to generate the IPG. IPG stretch only works in full duplex mode and when bit 28 is set in the Network Configuration register. The IPG Stretch register cannot be used to shrink the IPG below 96 bits.

If the back pressure bit is set in the Network Control register, or if the HDFC configuration bit is set in the UR register (10M or 100M half duplex mode), the transmit block transmits 64 bits of data, which can consist of 16 nibbles of 1011 or in bit rate mode 64 1s, whenever it sees an incoming frame to force a collision. This provides a way of implementing flow control in half duplex mode.

### 24.6.5 MAC Receive Block

All processing within the MAC receive block is implemented using a 16-bit data path. The MAC receive block checks for valid preamble, FCS, alignment and length, presents received frames to the FIFO interface and stores the frame destination address for use by the address checking block.

If, during the frame reception, the frame is found to be too long, a bad frame indication is sent to the FIFO interface. The receiver logic ceases to send data to memory as soon as this condition occurs.

At end of frame reception the receive block indicates to the DMA block whether the frame is good or bad. The DMA block will recover the current receive buffer if the frame was bad.

Ethernet frames are normally stored in DMA memory complete with the FCS. Setting the FCS remove bit in the network configuration (bit 17) causes frames to be stored without their corresponding FCS. The reported frame length field is reduced by four bytes to reflect this operation.

The receive block signals to the register block to increment the alignment, CRC (FCS), short frame, long frame, jabber or receive symbol errors when any of these exception conditions occur.

If bit 26 is set in the network configuration, CRC errors will be ignored and CRC errored frames will not be discarded, though the Frame Check Sequence Errors statistic register will still be incremented.

Additionally, if not enabled for jumbo frames mode, then bit[13] of the receiver descriptor word 1 will be updated to indicate the FCS validity for the particular frame. This is useful for applications such as EtherCAT whereby individual frames with FCS errors must be identified.

Received frames can be checked for length field error by setting the length field error frame discard bit of the Network Configuration register (bit-16). When this bit is set, the receiver compares a frame's measured length with the length field (bytes 13 and 14) extracted from the frame. The frame is discarded if the measured length is shorter. This checking procedure is for received frames between 64 bytes and 1518 bytes in length.

Each discarded frame is counted in the 10-bit length field error statistics register. Frames where the length field is greater than or equal to 0x0600 hex will not be checked.

### 24.6.6 Checksum Offload for IP, TCP and UDP

The GMAC can be programmed to perform IP, TCP and UDP checksum offloading in both receive and transmit directions, which is enabled by setting bit 24 in the Network Configuration register for receive and bit 11 in the DMA Configuration register for transmit.

IPv4 packets contain a 16-bit checksum field, which is the 16-bit 1's complement of the 1's complement sum of all 16-bit words in the header. TCP and UDP packets contain a 16-bit checksum field, which is the 16-bit 1's complement of the 1's complement sum of all 16-bit words in the header, the data and a conceptual IP pseudo header.

To calculate these checksums in software requires each byte of the packet to be processed. For TCP and UDP this can use a large amount of processing power. Offloading the checksum calculation to hardware can result in significant performance improvements.

For IP, TCP or UDP checksum offload to be useful, the operating system containing the protocol stack must be aware that this offload is available so that it can make use of the fact that the hardware can either generate or verify the checksum.

### 24.6.6.1 Receiver Checksum Offload

When receive checksum offloading is enabled in the GMAC Network Configuration Register (NCFGR.RXCOEN), the IPv4 header checksum is checked as per RFC 791, where the packet meets the following criteria:

- If present, the VLAN header must be four octets long and the CFI bit must not be set.
- Encapsulation must be RFC 894 Ethernet Type Encoding or RFC 1042 SNAP Encoding.
- IPv4 packet
- IP header is of a valid length

The GMAC also checks the TCP checksum as per RFC 793, or the UDP checksum as per RFC 768, if the following criteria are met:

- IPv4 or IPv6 packet
- Good IP header checksum (if IPv4)
- No IP fragmentation
- TCP or UDP packet

When an IP, TCP or UDP frame is received, the receive buffer descriptor gives an indication if the GMAC was able to verify the checksums. There is also an indication if the frame had SNAP encapsulation. These indication bits will replace the type ID match indication bits when the receive checksum offload is enabled. For details of these indication bits refer to [“Receive Buffer Descriptor Entry”](#).

If any of the checksums are verified as incorrect by the GMAC, the packet is discarded and the appropriate statistics counter incremented.

### 24.6.6.2 Transmitter Checksum Offload

The transmitter checksum offload is only available if the full store and forward mode is enabled. This is because the complete frame to be transmitted must be read into the packet buffer memory before the checksum can be calculated and written back into the headers at the beginning of the frame.

Transmitter checksum offload is enabled by setting bit [11] in the DMA Configuration register. When enabled, it will monitor the frame as it is written into the transmitter packet buffer memory to automatically detect the protocol of the frame. Protocol support is identical to the receiver checksum offload.

For transmit checksum generation and substitution to occur, the protocol of the frame must be recognized and the frame must be provided without the FCS field, by making sure that bit [16] of the transmit descriptor word 1 is clear. If the frame data already had the FCS field, this would be corrupted by the substitution of the new checksum fields.

If these conditions are met, the transmit checksum offload engine will calculate the IP, TCP and UDP checksums as appropriate. Once the full packet is completely written into packet buffer memory, the checksums will be valid and the relevant DPRAM locations will be updated for the new checksum fields as per standard IP/TCP and UDP packet structures.

If the transmitter checksum engine is prevented from generating the relevant checksums, bits [22:20] of the transmitter DMA writeback status will be updated to identify the reason for the error. Note that the

frame will still be transmitted but without the checksum substitution, as typically the reason that the substitution did not occur was that the protocol was not recognized.

### 24.6.7 MAC Filtering Block

The filter block determines which frames should be written to the FIFO interface and on to the DMA.

Whether a frame is passed depends on what is enabled in the Network Configuration register, the state of the external matching pins, the contents of the specific address, type and Hash registers and the frame's destination address and type field.

If bit 25 of the Network Configuration register is not set, a frame will not be copied to memory if the GMAC is transmitting in half duplex mode at the time a destination address is received.

Ethernet frames are transmitted a byte at a time, least significant bit first. The first six bytes (48 bits) of an Ethernet frame make up the destination address. The first bit of the destination address, which is the LSB of the first byte of the frame, is the group or individual bit. This is one for multicast addresses and zero for unicast. The all ones address is the broadcast address and a special case of multicast.

The GMAC supports recognition of four specific addresses. Each specific address requires two registers, Specific Address register Bottom and Specific Address register Top. Specific Address register Bottom stores the first four bytes of the destination address and Specific Address register Top contains the last two bytes. The addresses stored can be specific, group, local or universal.

The destination address of received frames is compared against the data stored in the Specific Address registers once they have been activated. The addresses are deactivated at reset or when their corresponding Specific Address register Bottom is written. They are activated when Specific Address register Top is written. If a receive frame address matches an active address, the frame is written to the FIFO interface and on to DMA memory.

Frames may be filtered using the type ID field for matching. Four type ID registers exist in the register address space and each can be enabled for matching by writing a one to the MSB (bit 31) of the respective register. When a frame is received, the matching is implemented as an OR function of the various types of match.

The contents of each type ID register (when enabled) are compared against the length/type ID of the frame being received (e.g., bytes 13 and 14 in non-VLAN and non-SNAP encapsulated frames) and copied to memory if a match is found. The encoded type ID match bits (Word 0, Bit 22 and Bit 23) in the receive buffer descriptor status are set indicating which type ID register generated the match, if the receive checksum offload is disabled.

The reset state of the type ID registers is zero, hence each is initially disabled.

The following example illustrates the use of the address and type ID match registers for a MAC address of 21:43:65:87:A9:CB:

Preamble	55
SFD	D5
DA (Octet 0 - LSB)	21
DA (Octet 1)	43
DA (Octet 2)	65
DA (Octet 3)	87

# SAM D5x/E5x Family Data Sheet

## GMAC - Ethernet MAC

DA (Octet 4)	A9
DA (Octet 5 - MSB)	CB
SA (LSB)	00 (see <b>Note</b> )
SA	00(see <b>Note</b> )
SA	00(see <b>Note</b> )
SA	00(see <b>Note</b> )
SA	00(see <b>Note</b> )
SA (MSB)	00(see <b>Note</b> )
Type ID (MSB)	43
Type ID (LSB)	21

**Note:** Contains the address of the transmitting device.

The previous sequence shows the beginning of an Ethernet frame. Byte order of transmission is from top to bottom, as shown. For a successful match to specific address 1, the following address matching registers must be set up:

Specific Address 1 Bottom register (SAB1) (Address 0x088) 0x87654321

Specific Address 1 Top register (SAT1) (Address 0x08C) 0x0000CBA9

For a successful match to the type ID, the following Type ID Match 1 register must be set up:

Type ID Match 1 register (TIDM1) (Address 0x0A8) 0x80004321

### 24.6.8 Broadcast Address

Frames with the broadcast address of 0xFFFFFFFF are stored to memory only if the 'no broadcast' bit in the Network Configuration register is set to zero.

### 24.6.9 Hash Addressing

The hash address register is 64 bits long and takes up two locations in the memory map. The least significant bits are stored in Hash Register Bottom and the most significant bits in Hash Register Top.

The unicast hash enable and the multicast hash enable bits in the Network Configuration register enable the reception of hash matched frames. The destination address is reduced to a 6-bit index into the 64-bit Hash register using the following hash function: The hash function is an XOR of every sixth bit of the destination address.

$$\text{hash\_index}[05] = \text{da}[05] \wedge \text{da}[11] \wedge \text{da}[17] \wedge \text{da}[23] \wedge \text{da}[29] \wedge \text{da}[35] \wedge \text{da}[41] \wedge \text{da}[47]$$

$$\text{hash\_index}[04] = \text{da}[04] \wedge \text{da}[10] \wedge \text{da}[16] \wedge \text{da}[22] \wedge \text{da}[28] \wedge \text{da}[34] \wedge \text{da}[40] \wedge \text{da}[46]$$

$$\text{hash\_index}[03] = \text{da}[03] \wedge \text{da}[09] \wedge \text{da}[15] \wedge \text{da}[21] \wedge \text{da}[27] \wedge \text{da}[33] \wedge \text{da}[39] \wedge \text{da}[45]$$

$$\text{hash\_index}[02] = \text{da}[02] \wedge \text{da}[08] \wedge \text{da}[14] \wedge \text{da}[20] \wedge \text{da}[26] \wedge \text{da}[32] \wedge \text{da}[38] \wedge \text{da}[44]$$

$$\text{hash\_index}[01] = \text{da}[01] \wedge \text{da}[07] \wedge \text{da}[13] \wedge \text{da}[19] \wedge \text{da}[25] \wedge \text{da}[31] \wedge \text{da}[37] \wedge \text{da}[43]$$

$$\text{hash\_index}[00] = \text{da}[00] \wedge \text{da}[06] \wedge \text{da}[12] \wedge \text{da}[18] \wedge \text{da}[24] \wedge \text{da}[30] \wedge \text{da}[36] \wedge \text{da}[42]$$

da[0] represents the least significant bit of the first byte received, that is, the multicast/unicast indicator, and da[47] represents the most significant bit of the last byte received.

If the hash index points to a bit that is set in the Hash register then the frame will be matched according to whether the frame is multicast or unicast.

A multicast match will be signaled if the multicast hash enable bit is set, da[0] is logic 1 and the hash index points to a bit set in the Hash register.

A unicast match will be signaled if the unicast hash enable bit is set, da[0] is logic 0 and the hash index points to a bit set in the Hash register.

To receive all multicast frames, the Hash register should be set with all ones and the multicast hash enable bit should be set in the Network Configuration register.

### 24.6.10 Copy all Frames (Promiscuous Mode)

If the Copy All Frames bit is set in the Network Configuration register then all frames (except those that are too long, too short, have FCS errors or have GRXER asserted during reception) will be copied to memory. Frames with FCS errors will be copied if bit 26 is set in the Network Configuration register.

### 24.6.11 Disable Copy of Pause Frames

Pause frames can be prevented from being written to memory by setting the disable copying of pause frames control bit 23 in the Network Configuration register. When set, pause frames are not copied to memory regardless of the Copy All Frames bit, whether a hash match is found, a type ID match is identified or if a destination address match is found.

### 24.6.12 VLAN Support

The following table describes an Ethernet encoded 802.1Q VLAN tag.

**Table 24-4. 802.1Q VLAN Tag**

TPID (Tag Protocol Identifier) 16 bits	TCI (Tag Control Information) 16 bits
0x8100	First 3 bits priority, then CFI bit, last 12 bits VID

The VLAN tag is inserted at the 13th byte of the frame adding an extra four bytes to the frame. To support these extra four bytes, the GMAC can accept frame lengths up to 1536 bytes by setting bit 8 in the Network Configuration register.

If the VID (VLAN identifier) is null (0x000) this indicates a priority-tagged frame.

The following bits in the receive buffer descriptor status word give information about VLAN tagged frames:-

- Bit 21 set if receive frame is VLAN tagged (i.e., type ID of 0x8100).
- Bit 20 set if receive frame is priority tagged (i.e., type ID of 0x8100 and null VID). (If bit 20 is set, bit 21 will be set also.)
- Bit 19, 18 and 17 set to priority if bit 21 is set.
- Bit 16 set to CFI if bit 21 is set.

The GMAC can be configured to reject all frames except VLAN tagged frames by setting the discard non-VLAN frames bit in the Network Configuration register.

### 24.6.13 Wake on LAN Support

The receive block supports Wake on LAN by detecting the following events on incoming receive frames:

- Magic packet
- Address Resolution Protocol (ARP) request to the device IP address



- Specific address 1 filter match
- Multicast hash filter match

These events can be individually enabled through bits [19:16] of the Wake on LAN register. Also, for Wake on LAN detection to occur, receive enable must be set in the Network Control register, however a receive buffer does not have to be available.

In case of an ARP request, specific address 1 or multicast filter events will occur even if the frame is errored. For magic packet events, the frame must be correctly formed and error free.

A magic packet event is detected if all of the following are true:

- Magic packet events are enabled through bit 16 of the Wake on LAN register
- The frame's destination address matches specific address 1
- The frame is correctly formed with no errors
- The frame contains at least 6 bytes of 0xFF for synchronization
- There are 16 repetitions of the contents of Specific Address 1 register immediately following the synchronization

An ARP request event is detected if all of the following are true:

- ARP request events are enabled through bit 17 of the Wake on LAN register
- Broadcasts are allowed by bit 5 in the Network Configuration register
- The frame has a broadcast destination address (bytes 1 to 6)
- The frame has a type ID field of 0x0806 (bytes 13 and 14)
- The frame has an ARP operation field of 0x0001 (bytes 21 and 22)
- The least significant 16 bits of the frame's ARP target protocol address (bytes 41 and 42) match the value programmed in bits[15:0] of the Wake on LAN register

The decoding of the ARP fields adjusts automatically if a VLAN tag is detected within the frame. The reserved value of 0x0000 for the Wake on LAN target address value will not cause an ARP request event, even if matched by the frame.

A specific address 1 filter match event will occur if all of the following are true:

- Specific address 1 events are enabled through bit 18 of the Wake on LAN register
- The frame's destination address matches the value programmed in the Specific Address 1 registers

A multicast filter match event will occur if all of the following are true:

- Multicast hash events are enabled through bit 19 of the Wake on LAN register
- Multicast hash filtering is enabled through bit 6 of the Network Configuration register
- The frame destination address matches against the multicast hash filter
- The frame destination address is not a broadcast

### 24.6.14 IEEE 1588 Support

IEEE 1588 is a standard for precision time synchronization in local area networks. It works with the exchange of special Precision Time Protocol (PTP) frames. The PTP messages can be transported over IEEE 802.3/Ethernet, over Internet Protocol Version 4 or over Internet Protocol Version 6 as described in the annex of IEEE P1588.D2.1.

GMAC output pins indicate the message time-stamp point (asserted on the start packet delimiter and de-asserted at end of frame) for all frames and the passage of PTP event frames (asserted when a PTP event frame is detected and de-asserted at end of frame).

# SAM D5x/E5x Family Data Sheet

## GMAC - Ethernet MAC

IEEE 802.1AS is a subset of IEEE 1588. One difference is that IEEE 802.1AS uses the Ethernet multicast address 0180C200000E for sync frame recognition whereas IEEE 1588 does not. GMAC is designed to recognize sync frames with both IEEE 802.1AS and IEEE 1588 addresses and so can support both 1588 and 802.1AS frame recognition simultaneously.

Synchronization between master and slave clocks is a two stage process.

First, the offset between the master and slave clocks is corrected by the master sending a sync frame to the slave with a follow up frame containing the exact time the sync frame was sent. Hardware assist modules at the master and slave side detect exactly when the sync frame was sent by the master and received by the slave. The slave then corrects its clock to match the master clock.

Second, the transmission delay between the master and slave is corrected. The slave sends a delay request frame to the master which sends a delay response frame in reply. Hardware assist modules at the master and slave side detect exactly when the delay request frame was sent by the slave and received by the master. The slave will now have enough information to adjust its clock to account for delay. For example, if the slave was assuming zero delay, the actual delay will be half the difference between the transmit and receive time of the delay request frame (assuming equal transmit and receive times) because the slave clock will be lagging the master clock by the delay time already.

The time-stamp is taken when the message time-stamp point passes the clock time-stamp point. This can generate an interrupt if enabled (IER). However, MAC Filtering configuration is needed to actually 'copy' the message to memory. For Ethernet, the message time-stamp point is the SFD and the clock time-stamp point is the MII interface. (The IEEE 1588 specification refers to sync and delay\_req messages as event messages as these require time-stamping. These events are captured in the registers TSSx, EFTx and EFRx, respectively. Follow up, delay response and management messages do not require time-stamping and are referred to as general messages.)

1588 version 2 defines two additional PTP event messages. These are the peer delay request (Pdelay\_Req) and peer delay response (Pdelay\_Resp) messages. These events are captured in the registers PEFTx and PEFRx, respectively. These messages are used to calculate the delay on a link. Nodes at both ends of a link send both types of frames (regardless of whether they contain a master or slave clock). The Pdelay\_Resp message contains the time at which a Pdelay\_Req was received and is itself an event message. The time at which a Pdelay\_Resp message is received is returned in a Pdelay\_Resp\_Follow\_Up message.

1588 version 2 introduces transparent clocks of which there are two kinds, peer-to-peer (P2P) and end-to-end (E2E). Transparent clocks measure the transit time of event messages through a bridge and amend a correction field within the message to allow for the transit time. P2P transparent clocks additionally correct for the delay in the receive path of the link using the information gathered from the peer delay frames. With P2P transparent clocks delay\_req messages are not used to measure link delay. This simplifies the protocol and makes larger systems more stable.

The GMAC recognizes four different encapsulations for PTP event messages:

1. 1588 version 1 (UDP/IPv4 multicast)
2. 1588 version 2 (UDP/IPv4 multicast)
3. 1588 version 2 (UDP/IPv6 multicast)
4. 1588 version 2 (Ethernet multicast)

**Table 24-5. Example of Sync Frame in 1588 Version 1 Format**

Frame Segment	Value
Preamble/SFD	55555555555555D5

# SAM D5x/E5x Family Data Sheet

## GMAC - Ethernet MAC

.....continued	
Frame Segment	Value
DA (Octets 0–5)	—
SA (Octets 6–11)	—
Type (Octets 12–13)	0800
IP stuff (Octets 14–22)	—
UDP (Octet 23)	11
IP stuff (Octets 24–29)	—
IP DA (Octets 30–32)	E00001
IP DA (Octet 33)	81 or 82 or 83 or 84
Source IP port (Octets 34–35)	—
Dest IP port (Octets 36–37)	013F
Other stuff (Octets 38–42)	—
Version PTP (Octet 43)	01
Other stuff (Octets 44–73)	—
Control (Octet 74)	00
Other stuff (Octets 75–168)	—

**Table 24-6. Example of Delay Request Frame in 1588 Version 1 Format**

Frame Segment	Value
Preamble/SFD	55555555555555D5
DA (Octets 0–5)	—
SA (Octets 6–11)	—
Type (Octets 12–13)	0800
IP stuff (Octets 14–22)	—
UDP (Octet 23)	11
IP stuff (Octets 24–29)	—
IP DA (Octets 30–32)	E00001
IP DA (Octet 33)	81 or 82 or 83 or 84
Source IP port (Octets 34–35)	—
Dest IP port (Octets 36–37)	013F
Other stuff (Octets 38–42)	—
Version PTP (Octet 43)	01
Other stuff (Octets 44–73)	—

# SAM D5x/E5x Family Data Sheet

## GMAC - Ethernet MAC

.....continued	
Frame Segment	Value
Control (Octet 74)	01
Other stuff (Octets 75–168)	—

For 1588 version 1 messages, sync and delay request frames are indicated by the GMAC if the frame type field indicates TCP/IP, UDP protocol is indicated, the destination IP address is 224.0.1.129/130/131 or 132, the destination UDP port is 319 and the control field is correct.

The control field is 0x00 for sync frames and 0x01 for delay request frames.

For 1588 version 2 messages, the type of frame is determined by looking at the message type field in the first byte of the PTP frame. Whether a frame is version 1 or version 2 can be determined by looking at the version PTP field in the second byte of both version 1 and version 2 PTP frames.

In version 2 messages sync frames have a message type value of 0x0, delay\_req have 0x1, Pdelay\_Req have 0x2 and Pdelay\_Resp have 0x3.

**Table 24-7. Example of Sync Frame in 1588 Version 2 (UDP/IPv4) Format**

Frame Segment	Value
Preamble/SFD	55555555555555D5
DA (Octets 0–5)	—
SA (Octets 6–11)	—
Type (Octets 12–13)	0800
IP stuff (Octets 14–22)	—
UDP (Octet 23)	11
IP stuff (Octets 24–29)	—
IP DA (Octets 30–33)	E0000181
Source IP port (Octets 34–35)	—
Dest IP port (Octets 36–37)	013F
Other stuff (Octets 38–41)	—
Message type (Octet 42)	00
Version PTP (Octet 43)	02

**Table 24-8. Example of Pdelay\_Req Frame in 1588 Version 2 (UDP/IPv4) Format**

Frame Segment	Value
Preamble/SFD	55555555555555D5
DA (Octets 0–5)	—
SA (Octets 6–11)	—
Type (Octets 12–13)	0800

# SAM D5x/E5x Family Data Sheet

## GMAC - Ethernet MAC

.....continued	
Frame Segment	Value
IP stuff (Octets 14–22)	—
UDP (Octet 23)	11
IP stuff (Octets 24–29)	—
IP DA (Octets 30–33)	E000006B
Source IP port (Octets 34–35)	—
Dest IP port (Octets 36–37)	013F
Other stuff (Octets 38–41)	—
Message type (Octet 42)	02
Version PTP (Octet 43)	02

**Table 24-9. Example of Sync Frame in 1588 Version 2 (UDP/IPv6) Format**

Frame Segment	Value
Preamble/SFD	55555555555555D5
DA (Octets 0–5)	—
SA (Octets 6–11)	—
Type (Octets 12–13)	86dd
IP stuff (Octets 14–19)	—
UDP (Octet 20)	11
IP stuff (Octets 21–37)	—
IP DA (Octets 38–53)	FF0X00000000018
Source IP port (Octets 54–55)	—
Dest IP port (Octets 56–57)	013F
Other stuff (Octets 58–61)	—
Message type (Octet 62)	00
Other stuff (Octets 63–93)	—
Version PTP (Octet 94)	02

**Table 24-10. Example of Pdelay\_Resp Frame in 1588 Version 2 (UDP/IPv6) Format**

Frame Segment	Value
Preamble/SFD	55555555555555D5
DA (Octets 0–5)	—
SA (Octets 6–11)	—

# SAM D5x/E5x Family Data Sheet

## GMAC - Ethernet MAC

.....continued	
Frame Segment	Value
Type (Octets 12–13)	86dd
IP stuff (Octets 14–19)	—
UDP (Octet 20)	11
IP stuff (Octets 21–37)	—
IP DA (Octets 38–53)	FF0200000000006B
Source IP port (Octets 54–55)	—
Dest IP port (Octets 56–57)	013F
Other stuff (Octets 58–61)	—
Message type (Octet 62)	03
Other stuff (Octets 63–93)	—
Version PTP (Octet 94)	02

For the multicast address 011B19000000 sync and delay request frames are recognized depending on the message type field, 00 for sync and 01 for delay request.

**Table 24-11. Example of Sync Frame in 1588 Version 2 (Ethernet Multicast) Format**

Frame Segment	Value
Preamble/SFD	55555555555555D5
DA (Octets 0–5)	011B19000000
SA (Octets 6–11)	—
Type (Octets 12–13)	88F7
Message type (Octet 14)	00
Version PTP (Octet 15)	02

Pdelay request frames need a special multicast address so they can pass through ports blocked by the spanning tree protocol. For the multicast address 0180C200000E sync, Pdelay\_Req and Pdelay\_Resp frames are recognized depending on the message type field, 00 for sync, 02 for pdelay request and 03 for pdelay response.

**Table 24-12. Example of Pdelay\_Req Frame in 1588 Version 2 (Ethernet Multicast) Format**

Frame Segment	Value
Preamble/SFD	55555555555555D5
DA (Octets 0–5)	0180C200000E
SA (Octets 6–11)	—
Type (Octets 12–13)	88F7
Message type (Octet 14)	00

.....continued	
Frame Segment	Value
Version PTP (Octet 15)	02

### 24.6.15 Time Stamp Unit

#### Overview

The TSU consists of a timer and registers to capture the time at which PTP event frames cross the message timestamp point. An interrupt is issued when a capture register is updated.

The 1588 time stamp unit (TSU) is implemented as a 94-bit timer.

- The 48 upper bits [93:46] of the timer count seconds and are accessible in the GMAC 1588 Timer Seconds High Register (TSH) and GMAC 1588 Timer Seconds Low Register (TSL).
- The 30 lower bits [45:16] of the timer count nanoseconds and are accessible in the GMAC 1588 Timer Nanoseconds Register (TN).
- The lowest 16 bits [15:0] of the timer count sub-nanoseconds.

The 46 lower bits roll over when they have counted to 1s. An interrupt is generated when the seconds increment. The timer increments by a programmable period (to approximately 15.2fs resolution) with each MCK period. The timer value can be read, written and adjusted with 1ns resolution (incremented or decremented) through the APB interface.

#### Timer Adjustment

The amount by which the timer increments each clock cycle is controlled by the Timer Increment register (TI). Bits [7:0] are the default increment value in nanoseconds. Additional 16 bits of sub-nanosecond resolution are available using the Timer Increment Sub-Nanoseconds register (TISUBN). If the rest of the register is written with zero, the timer increments by the value in [7:0], plus the value of the TISUBN for each clock cycle.

The TISUBN allows a resolution of approximately 15fs.

Bits [15:8] of the increment register are the alternative increment value in nanoseconds, and bits [23:16] are the number of increments after which the alternative increment value is used. If [23:16] are zero the alternative increment value will never be used.

Taking the example of 10.2MHz, there are 102 cycles every 10µs or 51 cycles every 5µs. So a timer with a 10.2MHz clock source is constructed by incrementing by 98ns for fifty cycles and then incrementing by 100ns (98ns × 50 + 100ns = 5000ns). This is programmed by writing the value 0x00326462 to the Timer Increment register (TI).

In a second example, a 49.8 MHz clock source requires 20ns for 248 cycles, followed by an increment of 40ns (20ns × 248 + 40ns = 5000ns). This is programmed by writing the value 0x00F82814 to the TI register.

The Number of Increments bit field in the TI register is 8 bit in size, so frequencies up to 50MHz are supported with 200kHz resolution.

Without the alternative increment field the period of the clock would be limited to an integer number of nanoseconds, resulting in supported clock frequencies of 8, 10, 20, 25, 40, 50, 100, 125, 200 and 250 MHz.

There are eight additional 80-bit registers that capture the time at which PTP event frames are transmitted and received. An interrupt is issued when these registers are updated. The TSU timer count value can be compared to a programmable comparison value. For the comparison, the 48 bits of the seconds value and the upper 22 bits of the nanoseconds value are used. A signal (GTSUCOMP) is output from the core to indicate when the TSU timer count value is equal to the comparison value stored in the TSU timer comparison value registers (GMAC.NSC, GMAC.SCL, and GMAC.SCH). An interrupt can also be generated (if enabled) when the TSU timer count value and comparison value are equal, mapped to bit 29 of the interrupt status register.

### 24.6.16 MAC 802.3 Pause Frame Support

**Note:** Refer to the Clause 31, and Annex 31A and 31B of the IEEE standard 802.3 for a full description of MAC 802.3 pause operation.

The following table shows the start of a MAC 802.3 pause frame.

**Table 24-13. Start of an 802.3 Pause Frame**

Address		Type (MAC Control Frame)	Pause	
Destination	Source		Opcode	Time
0x0180C2000001	6 bytes	0x8808	0x0001	2 bytes

The GMAC supports both hardware controlled pause of the transmitter, upon reception of a pause frame, and hardware generated pause frame transmission.

#### 24.6.16.1 802.3 Pause Frame Reception

The bit 13 of the Network Configuration register is the pause enable control for reception. If this bit is set, transmission will pause if a non zero pause quantum frame is received.

If a valid pause frame is received, then the Pause Time register is updated with the new frame's pause time, regardless of whether a previous pause frame is active or not. An interrupt (either bit 12 or bit 13 of the Interrupt Status register) is triggered when a pause frame is received, but only if the interrupt has been enabled (bit 12 and bit 13 of the Interrupt Mask register). Pause frames received with non zero quantum are indicated through the interrupt bit 12 of the Interrupt Status register. Pause frames received with zero quantum are indicated on bit 13 of the Interrupt Status register.

Once the Pause Time register is loaded and the frame currently being transmitted has been sent, no new frames are transmitted until the pause time reaches zero. The loading of a new pause time, and hence the pausing of transmission, only occurs when the GMAC is configured for full duplex operation. If the GMAC is configured for half duplex there will be no transmission pause, but the pause frame received interrupt will still be triggered. A valid pause frame is defined as having a destination address that matches either the address stored in Specific Address register '1' or if it matches the reserved address of 0x0180C2000001. It must also have the MAC control frame type ID of 0x8808 and have the pause opcode of 0x0001.

Pause frames that have frame check sequence (FCS) or other errors will be treated as invalid and will be discarded. Valid pause frames received will increment the pause frames received statistic register.

The pause time register decrements every 512 bit times once the transmission has stopped. For test purposes, the retry test bit can be set (bit 12 in the Network Configuration register) which causes the Pause Time register to decrement every GTXCK cycle once transmission has stopped.



The interrupt (bit 13 in the Interrupt Status register) is asserted whenever the Pause Time register decrements to zero (assuming it has been enabled by bit 13 in the Interrupt Mask register). This interrupt is also set when a zero quantum pause frame is received.

### 24.6.16.2 802.3 Pause Frame Transmission

Automatic transmission of pause frames is supported through the transmit pause frame bits of the Network Control register. If either bit 11 or bit 12 of the Network Control register is written with logic 1, an 802.3 pause frame will be transmitted, providing full duplex is selected in the Network Configuration register and the transmit block is enabled in the Network Control register.

Pause frame transmission will happen immediately if transmit is inactive or if transmit is active between the current frame and the next frame due to be transmitted.

Transmitted pause frames comprise the following:

- A destination address of 01-80-C2-00-00-01
- A source address taken from Specific Address register 1
- A type ID of 88-08 (MAC control frame)
- A pause opcode of 00-01
- A pause quantum register
- Fill of 00 to take the frame to minimum frame length
- Valid FCS

The pause quantum used in the generated frame will depend on the trigger source for the frame as follows:

- If bit 11 is written with a '1', the pause quantum will be taken from the Transmit Pause Quantum register. The Transmit Pause Quantum register resets to a value of 0xFFFF giving maximum pause quantum as default.
- If bit 12 is written with a '1', the pause quantum will be zero.

After transmission, a pause frame transmitted interrupt will be generated (bit 14 of the Interrupt Status register) and the only statistics register that will be incremented will be the Pause Frames Transmitted register.

Pause frames can also be transmitted by the MAC using normal frame transmission methods.

### 24.6.17 Energy Efficient Ethernet Support

#### Features

- Energy Efficient Ethernet according to IEEE 802.3az
- A system's transmit path can enter a low power mode if there is nothing to transmit.
- A PHY can detect whether its link partner's transmit path is in low power mode, and configure its own receive path to enter low power mode.
- Link remains up during lower power mode and no frames are dropped.
- Asymmetric, one direction can be in low power mode while the other is transmitting normally.
- LPI (Low Power Idle) signaling is used to control entry and exit to and from low power modes.  
**Note:** LPI signaling can only take place if both sides have indicated support for it through auto-negotiation.

#### Operation

- Low power control is done at the MII (reconciliation sublayer).

- As an architectural convenience in writing the 802.3az it is assumed that transmission is deferred by asserting carrier sense - in practice it will not be done this way. This system will know when it has nothing to transmit and only enter low power mode when it is not transmitting.
- LPI should not be requested unless the link has been up for at least one second.
- LPI is signaled on the MII transmit path by asserting 0x01 on txd with tx\_en low and tx\_er high.
- A PHY on seeing LPI requested on the MII will send the sleep signal before going quiet. After going quiet it will periodically emit refresh signals.
- The sleep, quiet and refresh periods are defined in 802.3az, Table 78-2.
- LPI mode ends by transmitting normal idle for the wake time. There is a default time for this but it can be adjusted in software using the Link Layer Discovery Protocol (LLDP) described in 802.3az, Clause 79.
- LPI is indicated at the receive side when sleep and refresh signaling has been detected.

### 24.6.18 802.1Qav Support - Credit-based Shaping

A credit-based shaping algorithm is available on the two highest priority queues and is defined in the standard 802.1Qav: Forwarding and Queuing Enhancements for Time-Sensitive Streams. This allows traffic on these queues to be limited and to allow other queues to transmit.

Traffic shaping is enabled via the CBS (Credit Based Shaping) Control register. This enables a counter which stores the amount of transmit 'credit', measured in bytes that a particular queue has. A queue may only transmit if it has non-negative credit. If a queue has data to send, but is held off from doing as another queue is transmitting, then credit will accumulate in the credit counter at the rate defined in the IdleSlope register (CBSISQx) for that queue.

**portTransmitRate** is the transmission rate, in bits per second, that the underlying MAC service that supports transmission through the Port provides. The value of this parameter is determined by the operation of the MAC. IdleSlope is the rate of change of increasing credit when waiting to transmit and must be less than the value of the portTransmitRate.

**IdleSlope** is the rate of change of credit when waiting to transmit and must be less than the value of the portTransmitRate.

The max value of IdleSlope (or sendSlope) is  $(\text{portTransmitRate} / \text{bits\_per\_MII\_Clock})$ .

In case of 100 Mbps, maximum IdleSlope =  $(100 \text{ Mbps} / 4) = 0x17D7840$ .

When this queue is transmitting the credit counter is decremented at the rate of sendSlope which is defined as  $(\text{portTransmitRate} - \text{IdleSlope})$ . A queue can accumulate negative credit when transmitting which will hold off any other transfers from that queue until credit returns to a non-negative value. No transfers are halted when a queue's credit becomes negative; it will accumulate negative credit until the transfer completes.

The highest priority queue always has priority regardless of which queue has the most credit.

### 24.6.19 PHY Interface

Different PHY interfaces are supported by the Ethernet MAC:

- MII
- RMII

The MII interface is provided for 10/100 operation and uses txd[3:0] and rxd[3:0]. The RMII interface is provided for 10/100 operation and uses txd[1:0] and rxd[1:0].

### 24.6.20 10/100 Operation

The 10/100 Mbps speed bit in the Network Configuration register is used to select between 10 Mbps and 100 Mbps.

### 24.6.21 Jumbo Frames

The jumbo frames enable bit in the Network Configuration register allows the GMAC, in its default configuration, to receive jumbo frames up to 10240 bytes in size. This operation does not form part of the IEEE 802.3 specification and is normally disabled. When jumbo frames are enabled, frames received with a frame size greater than 10240 bytes are discarded.

## 24.7 Programming Interface

### 24.7.1 Initialization

#### 24.7.1.1 Configuration

Initialization of the GMAC configuration (e.g., loop back mode, frequency ratios) must be done while the transmit and receive circuits are disabled. See the description of the Network Control register and Network Configuration register earlier in this document.

To change loop back mode, the following sequence of operations must be followed:

1. Write to Network Control register to disable transmit and receive circuits.
2. Write to Network Control register to change loop back mode.
3. Write to Network Control register to re-enable transmit or receive circuits.

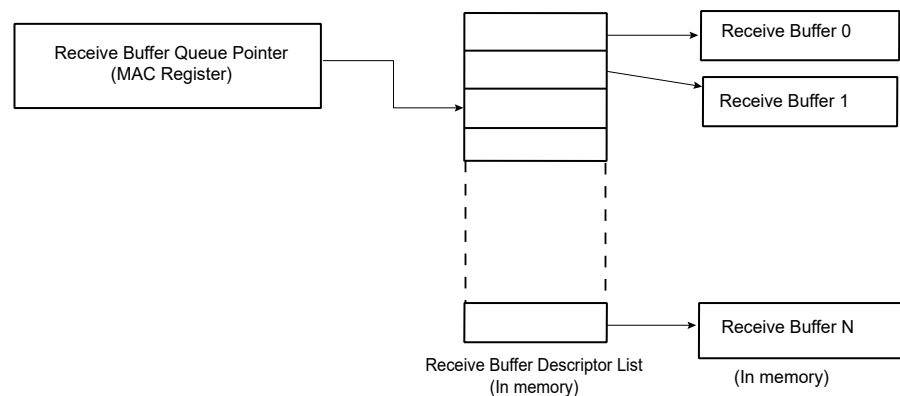
Note: These writes to the Network Control register cannot be combined in any way.

#### 24.7.1.2 Receive Buffer List

Receive data is written to areas of data (i.e., buffers) in system memory. These buffers are listed in another data structure that also resides in main memory. This data structure (receive buffer queue) is a sequence of descriptor entries as defined in [Table 1-6 "Receive Buffer Descriptor Entry"](#).

The Receive Buffer Queue Pointer register points to this data structure.

**Figure 24-3. Receive Buffer List**



To create the list of buffers:

1. Allocate a number (N) of buffers of X bytes in system memory, where X is the DMA buffer length programmed in the DMA Configuration register.
2. Allocate an area 8N bytes for the receive buffer descriptor list in system memory and create N entries in this list. Mark all entries in this list as owned by GMAC, i.e., bit 0 of word 0 set to 0.

3. Mark the last descriptor in the queue with the wrap bit (bit 1 in word 0 set to 1).
4. Write address of receive buffer descriptor list and control information to GMAC register receive buffer queue pointer
5. The receive circuits can then be enabled by writing to the address recognition registers and the Network Control register.

### 24.7.1.3 Transmit Buffer List

Transmit data is read from areas of data (the buffers) in system memory. These buffers are listed in another data structure that also resides in main memory. This data structure (Transmit Buffer Queue) is a sequence of descriptor entries as defined in [Table 1-7 “Transmit Buffer Descriptor Entry”](#).

The Transmit Buffer Queue Pointer register points to this data structure.

To create this list of buffers:

1. Allocate a number (N) of buffers of between 1 and 2047 bytes of data to be transmitted in system memory. Up to 128 buffers per frame are allowed.
2. Allocate an area 8N bytes for the transmit buffer descriptor list in system memory and create N entries in this list. Mark all entries in this list as owned by GMAC, i.e., bit 31 of word 1 set to 0.
3. Mark the last descriptor in the queue with the wrap bit (bit 30 in word 1 set to 1).
4. Write address of transmit buffer descriptor list and control information to GMAC register transmit buffer queue pointer.
5. The transmit circuits can then be enabled by writing to the Network Control register.

### 24.7.1.4 Address Matching

The GMAC register pair hash address and the four Specific Address register pairs must be written with the required values. Each register pair comprises of a bottom register and top register, with the bottom register being written first. The address matching is disabled for a particular register pair after the bottom register has been written and re-enabled when the top register is written. Each register pair may be written at any time, regardless of whether the receive circuits are enabled or disabled.

As an example, to set Specific Address register 1 to recognize destination address 21:43:65:87:A9:CB, the following values are written to Specific Address register 1 bottom and Specific Address register 1 top:

- Specific Address register 1 bottom bits 31:0 (0x98): 0x8765\_4321.
- Specific Address register 1 top bits 31:0 (0x9C): 0x0000\_CBA9.

### 24.7.1.5 PHY Maintenance

The PHY Maintenance register is implemented as a shift register. Writing to the register starts a shift operation which is signalled as complete when bit two is set in the Network Status register (about 2000 MCK cycles later when bits 18:16 are set to 010 in the Network Configuration register). An interrupt is generated as this bit is set.

During this time, the MSB of the register is output on the MDIO pin and the LSB updated from the MDIO pin with each Management Data Clock (MDC) cycle. This causes the transmission of a PHY management frame on MDIO. See section 22.2.4.5 of the IEEE 802.3 standard.

Reading during the shift operation will return the current contents of the shift register. At the end of the management operation the bits will have shifted back to their original locations. For a read operation the data bits are updated with data read from the PHY. It is important to write the correct values to the register to ensure a valid PHY management frame is produced.

The Management Data Clock (MDC) should not toggle faster than 2.5 MHz (minimum period of 400 ns), as defined by the IEEE 802.3 standard. MDC is generated by dividing down MCK. Three bits in the Network Configuration register determine by how much MCK should be divided to produce MDC.

### 24.7.1.6 Interrupts

There are 18 interrupt conditions that are detected within the GMAC. The conditions are ORed to make a single interrupt. Depending on the overall system design this may be passed through a further level of interrupt collection (interrupt controller). On receipt of the interrupt signal, the CPU enters the interrupt handler. Refer to the device interrupt controller documentation to identify that it is the GMAC that is generating the interrupt. To ascertain which interrupt, read the Interrupt Status register. Note that in the default configuration this register will clear itself after being read, though this may be configured to be write-one-to-clear if desired.

At reset all interrupts are disabled. To enable an interrupt, write to Interrupt Enable register with the pertinent interrupt bit set to 1. To disable an interrupt, write to Interrupt Disable register with the pertinent interrupt bit set to 1. To check whether an interrupt is enabled or disabled, read Interrupt Mask register. If the bit is set to 1, the interrupt is disabled.

### 24.7.1.7 Transmitting Frames

The procedure to set up a frame for transmission is the following:

1. Enable transmit in the Network Control register.
2. Allocate an area of system memory for transmit data. This does not have to be contiguous, varying byte lengths can be used if they conclude on byte borders.
3. Set-up the transmit buffer list by writing buffer addresses to word zero of the transmit buffer descriptor entries and control and length to word one.
4. Write data for transmission into the buffers pointed to by the descriptors.
5. Write the address of the first buffer descriptor to transmit buffer descriptor queue pointer.
6. Enable appropriate interrupts.
7. Write to the transmit start bit (TSTART) in the Network Control register.

### 24.7.1.8 Receiving Frames

When a frame is received and the receive circuits are enabled, the GMAC checks the address and, in the following cases, the frame is written to system memory:

- If it matches one of the four Specific Address registers.
- If it matches one of the four type ID registers.
- If it matches the hash address function.
- If it is a broadcast address (0xFFFFFFFF) and broadcasts are allowed.
- If the GMAC is configured to “copy all frames”.

The register receive buffer queue pointer points to the next entry in the receive buffer descriptor list and the GMAC uses this as the address in system memory to write the frame to.

Once the frame has been completely and successfully received and written to system memory, the GMAC then updates the receive buffer descriptor entry (see [Table 1-6 “Receive Buffer Descriptor Entry”](#)) with the reason for the address match and marks the area as being owned by software. Once this is complete, a receive complete interrupt is set. Software is then responsible for copying the data to the application area and releasing the buffer (by writing the ownership bit back to 0).

If the GMAC is unable to write the data at a rate to match the incoming frame, then a receive overrun interrupt is set. If there is no receive buffer available, i.e., the next buffer is still owned by software, a

# SAM D5x/E5x Family Data Sheet

## GMAC - Ethernet MAC

receive buffer not available interrupt is set. If the frame is not successfully received, a statistics register is incremented and the frame is discarded without informing software.

### 24.7.2 Statistics Registers

Statistics registers are described in the User Interface beginning with [Section 1.8.48 "GMAC Octets Transmitted Low Register"](#) and ending with [Section 1.8.92 "GMAC UDP Checksum Errors Register"](#).

The statistics register block begins at 0x100 and runs to 0x1B0, and comprises the registers listed below.

Octets Transmitted Low Register	Broadcast Frames Received Register
Octets Transmitted High Register	Multicast Frames Received Register
Frames Transmitted Register	Pause Frames Received Register
Broadcast Frames Transmitted Register	64 Byte Frames Received Register
Multicast Frames Transmitted Register	65 to 127 Byte Frames Received Register
Pause Frames Transmitted Register	128 to 255 Byte Frames Received Register
64 Byte Frames Transmitted Register	256 to 511 Byte Frames Received Register
65 to 127 Byte Frames Transmitted Register	512 to 1023 Byte Frames Received Register
128 to 255 Byte Frames Transmitted Register	1024 to 1518 Byte Frames Received Register
256 to 511 Byte Frames Transmitted Register	1519 to Maximum Byte Frames Received Register
512 to 1023 Byte Frames Transmitted Register	Undersize Frames Received Register
1024 to 1518 Byte Frames Transmitted Register	Oversize Frames Received Register
Greater Than 1518 Byte Frames Transmitted Register	Jabbers Received Register
Transmit Underruns Register	Frame Check Sequence Errors Register
Single Collision Frames Register	Length Field Frame Errors Register
Multiple Collision Frames Register	Receive Symbol Errors Register
Excessive Collisions Register	Alignment Errors Register
Late Collisions Register	Receive Resource Errors Register
Deferred Transmission Frames Register	Receive Overrun Register
Carrier Sense Errors Register	IP Header Checksum Errors Register
Octets Received Low Register	TCP Checksum Errors Register
Octets Received High Register	UDP Checksum Errors Register
Frames Received Register	

These registers reset to zero on a read and stick at all ones when they count to their maximum value. They should be read frequently enough to prevent loss of data.

The receive statistics registers are only incremented when the receive enable bit (RXEN) is set in the Network Control register.

# SAM D5x/E5x Family Data Sheet

## GMAC - Ethernet MAC

---

---

Once a statistics register has been read, it is automatically cleared. When reading the Octets Transmitted and Octets Received registers, bits 31:0 should be read prior to bits 47:32 to ensure reliable operation.

# SAM D5x/E5x Family Data Sheet

## GMAC - Ethernet MAC

### 24.8 Register Summary

Offset	Name	Bit Pos.									
0x00	NCR	7:0	WESTAT	INCSTAT	CLRSTAT	MPE	TXEN	RXEN	LBL		
		15:8	SRTSM			TXZQPF	TXPF	THALT	TSTART	BP	
		23:16					LPI	FNP	TXPBPF	ENPBPR	
		31:24									
0x04	NCFGR	7:0	UNIHEN	MTIHEN	NBC	CAF	JFRAME	DNVLAN	FD	SPD	
		15:8	RXBUFO[1:0]		PEN	RTY				MAXFS	
		23:16	DCPF	DBW[1:0]		CLK[2:0]			RFCS	LFERD	
		31:24		IRXER	RXBP	IPGSEN		IRXFCS	EFRHD	RXCOEN	
0x08	NSR	7:0						IDLE	MDIO		
		15:8									
		23:16									
		31:24									
0x0C	UR	7:0								MII	
		15:8									
		23:16									
		31:24									
0x10	DCFGR	7:0	ESPA	ESMA		FBLDO[4:0]					
		15:8				TXCOEN	TXPBMS	RXBMS[1:0]			
		23:16	DRBS[7:0]								
		31:24								DDRP	
0x14	TSR	7:0		UND	TXCOMP	TFC	TXGO	RLE	COL	UBR	
		15:8								HRESP	
		23:16									
		31:24									
0x18	RBQB	7:0	ADDR[5:0]								
		15:8	ADDR[13:6]								
		23:16	ADDR[21:14]								
		31:24	ADDR[29:22]								
0x1C	TBQB	7:0	ADDR[5:0]								
		15:8	ADDR[13:6]								
		23:16	ADDR[21:14]								
		31:24	ADDR[29:22]								
0x20	RSR	7:0					HNO	RXOVR	REC	BNA	
		15:8									
		23:16									
		31:24									
0x24	ISR	7:0	TCOMP	TFC	RLEX	TUR	TXUBR	RXUBR	RCOMP	MFS	
		15:8		PFTR	PTZ	PFNZ	HRESP	ROVR			
		23:16	PDRSFR	PDRQFR	SFT	DRQFT	SFR	DRQFR			
		31:24			TSUCMP	WOL		SRI	PDRSFT	PDRQFT	



# SAM D5x/E5x Family Data Sheet

## GMAC - Ethernet MAC

.....continued

Offset	Name	Bit Pos.								
0x28	IER	7:0	TCOMP	TFC	RLEX	TUR	TXUBR	RXUBR	RCOMP	MFS
		15:8	EXINT	PFTR	PTZ	PFNZ	HRESP	ROVR		
		23:16	PDRSFR	PDRQFR	SFT	DRQFT	SFR	DRQFR		
		31:24			TSUCMP	WOL		SRI	PDRSFT	PDRQFT
0x2C	IDR	7:0	TCOMP	TFC	RLEX	TUR	TXUBR	RXUBR	RCOMP	MFS
		15:8	EXINT	PFTR	PTZ	PFNZ	HRESP	ROVR		
		23:16	PDRSFR	PDRQFR	SFT	DRQFT	SFR	DRQFR		
		31:24			TSUCMP	WOL	RXLPIBSC	SRI	PDRSFT	PDRQFT
0x30	IMR	7:0	TCOMP	TFC	RLEX	TUR	TXUBR	RXUBR	RCOMP	MFS
		15:8	EXINT	PFTR	PTZ	PFNZ	HRESP	ROVR		
		23:16	PDRSFR	PDRQFR	SFT	DRQFT	SFR	DRQFR		
		31:24			TSUCMP	WOL		SRI	PDRSFT	PDRQFT
0x34	MAN	7:0	DATA[7:0]							
		15:8	DATA[15:8]							
		23:16	PHYA[0:0]	REGA[4:0]					WTN[1:0]	
		31:24	WZO	CLTTO	OP[1:0]		PHYA[4:1]			
0x38	RPQ	7:0	RPQ[7:0]							
		15:8	RPQ[15:8]							
		23:16								
		31:24								
0x3C	TPQ	7:0	TPQ[7:0]							
		15:8	TPQ[15:8]							
		23:16								
		31:24								
0x40	TPSF	7:0	TPB1ADR[7:0]							
		15:8					TPB1ADR[11:8]			
		23:16								
		31:24	ENTXP							
0x44	RPSF	7:0	RPB1ADR[7:0]							
		15:8					RPB1ADR[11:8]			
		23:16								
		31:24	ENRXP							
0x48	RJFML	7:0	FML[7:0]							
		15:8			FML[13:8]					
		23:16								
		31:24								
0x4C ... 0x7F	Reserved									
0x80	HRB	7:0	ADDR[7:0]							
		15:8	ADDR[15:8]							
		23:16	ADDR[23:16]							
		31:24	ADDR[31:24]							

# SAM D5x/E5x Family Data Sheet

## GMAC - Ethernet MAC

.....continued

Offset	Name	Bit Pos.									
0x84	HRT	7:0	ADDR[7:0]								
		15:8	ADDR[15:8]								
		23:16	ADDR[23:16]								
		31:24	ADDR[31:24]								
0x88	SAB0	7:0	ADDR[7:0]								
		15:8	ADDR[15:8]								
		23:16	ADDR[23:16]								
		31:24	ADDR[31:24]								
0x8C	SAT0	7:0	ADDR[7:0]								
		15:8	ADDR[15:8]								
		23:16									
		31:24									
0x90	SAB1	7:0	ADDR[7:0]								
		15:8	ADDR[15:8]								
		23:16	ADDR[23:16]								
		31:24	ADDR[31:24]								
0x94	SAT1	7:0	ADDR[7:0]								
		15:8	ADDR[15:8]								
		23:16									
		31:24									
0x98	SAB2	7:0	ADDR[7:0]								
		15:8	ADDR[15:8]								
		23:16	ADDR[23:16]								
		31:24	ADDR[31:24]								
0x9C	SAT2	7:0	ADDR[7:0]								
		15:8	ADDR[15:8]								
		23:16									
		31:24									
0xA0	SAB3	7:0	ADDR[7:0]								
		15:8	ADDR[15:8]								
		23:16	ADDR[23:16]								
		31:24	ADDR[31:24]								
0xA4	SAT3	7:0	ADDR[7:0]								
		15:8	ADDR[15:8]								
		23:16									
		31:24									
0xA8	TIDM0	7:0	TID[7:0]								
		15:8	TID[15:8]								
		23:16									
		31:24	ENIDn								
0xAC	TIDM1	7:0	TID[7:0]								
		15:8	TID[15:8]								
		23:16									
		31:24	ENIDn								

# SAM D5x/E5x Family Data Sheet

## GMAC - Ethernet MAC

.....continued											
Offset	Name	Bit Pos.									
0xB0	TIDM2	7:0	TID[7:0]								
		15:8	TID[15:8]								
		23:16									
		31:24	ENIDn								
0xB4	TIDM3	7:0	TID[7:0]								
		15:8	TID[15:8]								
		23:16									
		31:24	ENIDn								
0xB8	WOL	7:0	IP[7:0]								
		15:8	IP[15:8]								
		23:16					MTI	SA1	ARP	MAG	
		31:24									
0xBC	IPGS	7:0	FL[7:0]								
		15:8	FL[15:8]								
		23:16									
		31:24									
0xC0	SVLAN	7:0	VLAN_TYPE[7:0]								
		15:8	VLAN_TYPE[15:8]								
		23:16									
		31:24	ESVLAN								
0xC4 ... 0xC7	Reserved										
0xC8	SAMB1	7:0	ADDR[7:0]								
		15:8	ADDR[15:8]								
		23:16	ADDR[23:16]								
		31:24	ADDR[31:24]								
0xCC	SAMT1	7:0	ADDR[7:0]								
		15:8	ADDR[15:8]								
		23:16									
		31:24									
0xD0 ... 0xDB	Reserved										
0xDC	NSC	7:0	NANOSEC[7:0]								
		15:8	NANOSEC[15:8]								
		23:16					NANOSEC[20:16]				
		31:24									
0xE0	SCL	7:0	SEC[7:0]								
		15:8	SEC[15:8]								
		23:16	SEC[23:16]								
		31:24	SEC[31:24]								

# SAM D5x/E5x Family Data Sheet

## GMAC - Ethernet MAC

.....continued

Offset	Name	Bit Pos.									
0xE4	SCH	7:0	SEC[7:0]								
		15:8	SEC[15:8]								
		23:16									
		31:24									
0xE8	EFTSH	7:0	RUD[7:0]								
		15:8	RUD[15:8]								
		23:16									
		31:24									
0xEC	EFRSH	7:0	RUD[7:0]								
		15:8	RUD[15:8]								
		23:16									
		31:24									
0xF0	PEFTSH	7:0	RUD[7:0]								
		15:8	RUD[15:8]								
		23:16									
		31:24									
0xF4	PEFRSH	7:0	RUD[7:0]								
		15:8	RUD[15:8]								
		23:16									
		31:24									
0xF8 ... 0xFF	Reserved										
0x0100	OTLO	7:0	TXO[7:0]								
		15:8	TXO[15:8]								
		23:16	TXO[23:16]								
		31:24	TXO[31:24]								
0x0104	OTHI	7:0	TXO[7:0]								
		15:8	TXO[15:8]								
		23:16									
		31:24									
0x0108	FT	7:0	FTX[7:0]								
		15:8	FTX[15:8]								
		23:16	FTX[23:16]								
		31:24	FTX[31:24]								
0x010C	BCFT	7:0	BFTX[7:0]								
		15:8	BFTX[15:8]								
		23:16	BFTX[23:16]								
		31:24	BFTX[31:24]								
0x0110	MFT	7:0	MFTX[7:0]								
		15:8	MFTX[15:8]								
		23:16	MFTX[23:16]								
		31:24	MFTX[31:24]								

# SAM D5x/E5x Family Data Sheet

## GMAC - Ethernet MAC

.....continued

Offset	Name	Bit Pos.							
0x0114	PFT	7:0	PFTX[7:0]						
		15:8	PFTX[15:8]						
		23:16							
		31:24							
0x0118	BFT64	7:0	NFTX[7:0]						
		15:8	NFTX[15:8]						
		23:16	NFTX[23:16]						
		31:24	NFTX[31:24]						
0x011C	TBFT127	7:0	NFTX[7:0]						
		15:8	NFTX[15:8]						
		23:16	NFTX[23:16]						
		31:24	NFTX[31:24]						
0x0120	TBFT255	7:0	NFTX[7:0]						
		15:8	NFTX[15:8]						
		23:16	NFTX[23:16]						
		31:24	NFTX[31:24]						
0x0124	TBFT511	7:0	NFTX[7:0]						
		15:8	NFTX[15:8]						
		23:16	NFTX[23:16]						
		31:24	NFTX[31:24]						
0x0128	TBFT1023	7:0	NFTX[7:0]						
		15:8	NFTX[15:8]						
		23:16	NFTX[23:16]						
		31:24	NFTX[31:24]						
0x012C	TBFT1518	7:0	NFTX[7:0]						
		15:8	NFTX[15:8]						
		23:16	NFTX[23:16]						
		31:24	NFTX[31:24]						
0x0130	GTBFT1518	7:0	NFTX[7:0]						
		15:8	NFTX[15:8]						
		23:16	NFTX[23:16]						
		31:24	NFTX[31:24]						
0x0134	TUR	7:0	TXUNR[7:0]						
		15:8							TXUNR[9:8]
		23:16							
		31:24							
0x0138	SCF	7:0	SCOL[7:0]						
		15:8	SCOL[15:8]						
		23:16							SCOL[17:16]
		31:24							
0x013C	MCF	7:0	MCOL[7:0]						
		15:8	MCOL[15:8]						
		23:16							MCOL[17:16]
		31:24							

# SAM D5x/E5x Family Data Sheet

## GMAC - Ethernet MAC

.....continued

Offset	Name	Bit Pos.								
0x0140	EC	7:0	XCOL[7:0]							
		15:8								XCOL[9:8]
		23:16								
		31:24								
0x0144	LC	7:0	LCOL[7:0]							
		15:8								LCOL[9:8]
		23:16								
		31:24								
0x0148	DTF	7:0	DEFT[7:0]							
		15:8	DEFT[15:8]							
		23:16								DEFT[17:16]
		31:24								
0x014C	CSE	7:0	CSR[7:0]							
		15:8								CSR[9:8]
		23:16								
		31:24								
0x0150	ORLO	7:0	RXO[7:0]							
		15:8	RXO[15:8]							
		23:16	RXO[23:16]							
		31:24	RXO[31:24]							
0x0154	ORHI	7:0	RXO[7:0]							
		15:8	RXO[15:8]							
		23:16								
		31:24								
0x0158	FR	7:0	FRX[7:0]							
		15:8	FRX[15:8]							
		23:16	FRX[23:16]							
		31:24	FRX[31:24]							
0x015C	BCFR	7:0	BFRX[7:0]							
		15:8	BFRX[15:8]							
		23:16	BFRX[23:16]							
		31:24	BFRX[31:24]							
0x0160	MFR	7:0	MFRX[7:0]							
		15:8	MFRX[15:8]							
		23:16	MFRX[23:16]							
		31:24	MFRX[31:24]							
0x0164	PFR	7:0	PFRX[7:0]							
		15:8	PFRX[15:8]							
		23:16								
		31:24								
0x0168	BFR64	7:0	NFRX[7:0]							
		15:8	NFRX[15:8]							
		23:16	NFRX[23:16]							
		31:24	NFRX[31:24]							

# SAM D5x/E5x Family Data Sheet

## GMAC - Ethernet MAC

.....continued

Offset	Name	Bit Pos.								
0x016C	TBFR127	7:0	NFRX[7:0]							
		15:8	NFRX[15:8]							
		23:16	NFRX[23:16]							
		31:24	NFRX[31:24]							
0x0170	TBFR255	7:0	NFRX[7:0]							
		15:8	NFRX[15:8]							
		23:16	NFRX[23:16]							
		31:24	NFRX[31:24]							
0x0174	TBFR511	7:0	NFRX[7:0]							
		15:8	NFRX[15:8]							
		23:16	NFRX[23:16]							
		31:24	NFRX[31:24]							
0x0178	TBFR1023	7:0	NFRX[7:0]							
		15:8	NFRX[15:8]							
		23:16	NFRX[23:16]							
		31:24	NFRX[31:24]							
0x017C	TBFR1518	7:0	NFRX[7:0]							
		15:8	NFRX[15:8]							
		23:16	NFRX[23:16]							
		31:24	NFRX[31:24]							
0x0180	TMXBFR	7:0	NFRX[7:0]							
		15:8	NFRX[15:8]							
		23:16	NFRX[23:16]							
		31:24	NFRX[31:24]							
0x0184	UFR	7:0	UFRX[7:0]							
		15:8							UFRX[9:8]	
		23:16								
		31:24								
0x0188	OFR	7:0	OFRX[7:0]							
		15:8							OFRX[9:8]	
		23:16								
		31:24								
0x018C	JR	7:0	JRX[7:0]							
		15:8							JRX[9:8]	
		23:16								
		31:24								
0x0190	FCSE	7:0	FCKR[7:0]							
		15:8							FCKR[9:8]	
		23:16								
		31:24								
0x0194	LFFE	7:0	LFRX[7:0]							
		15:8							LFRX[9:8]	
		23:16								
		31:24								

# SAM D5x/E5x Family Data Sheet

## GMAC - Ethernet MAC

.....continued

Offset	Name	Bit Pos.								
0x0198	RSE	7:0	RXSE[7:0]							
		15:8								RXSE[9:8]
		23:16								
		31:24								
0x019C	AE	7:0	AER[7:0]							
		15:8								AER[9:8]
		23:16								
		31:24								
0x01A0	RRE	7:0	RXRER[7:0]							
		15:8	RXRER[15:8]							
		23:16								RXRER[17:16]
		31:24								
0x01A4	ROE	7:0	RXOVR[7:0]							
		15:8								RXOVR[9:8]
		23:16								
		31:24								
0x01A8	IHCE	7:0	HCKER[7:0]							
		15:8								
		23:16								
		31:24								
0x01AC	TCE	7:0	TCKER[7:0]							
		15:8								
		23:16								
		31:24								
0x01B0	UCE	7:0	UCKER[7:0]							
		15:8								
		23:16								
		31:24								
0x01B4 ... 0x01BB	Reserved									
0x01BC	TISUBN	7:0	LSBTIR[7:0]							
		15:8	LSBTIR[15:8]							
		23:16								
		31:24								
0x01C0	TSH	7:0	TCS[7:0]							
		15:8	TCS[15:8]							
		23:16								
		31:24								
0x01C4 ... 0x01C7	Reserved									



# SAM D5x/E5x Family Data Sheet

## GMAC - Ethernet MAC

.....continued									
Offset	Name	Bit Pos.							
0x01C8	TSSL	7:0	VTS[7:0]						
		15:8	VTS[15:8]						
		23:16	VTS[23:16]						
		31:24	VTS[31:24]						
0x01CC	TSSN	7:0	VTN[7:0]						
		15:8	VTN[15:8]						
		23:16	VTN[23:16]						
		31:24			VTN[29:24]				
0x01D0	TSL	7:0	TCS[7:0]						
		15:8	TCS[15:8]						
		23:16	TCS[23:16]						
		31:24	TCS[31:24]						
0x01D4	TN	7:0	TNS[7:0]						
		15:8	TNS[15:8]						
		23:16	TNS[23:16]						
		31:24			TNS[29:24]				
0x01D8	TA	7:0	ITDT[7:0]						
		15:8	ITDT[15:8]						
		23:16	ITDT[23:16]						
		31:24	ADJ		ITDT[29:24]				
0x01DC	TI	7:0	CNS[7:0]						
		15:8	ACNS[7:0]						
		23:16	NIT[7:0]						
		31:24							
0x01E0	EFTSL	7:0	RUD[7:0]						
		15:8	RUD[15:8]						
		23:16	RUD[23:16]						
		31:24	RUD[31:24]						
0x01E4	EFTN	7:0	RUD[7:0]						
		15:8	RUD[15:8]						
		23:16	RUD[23:16]						
		31:24			RUD[29:24]				
0x01E8	EFRSL	7:0	RUD[7:0]						
		15:8	RUD[15:8]						
		23:16	RUD[23:16]						
		31:24	RUD[31:24]						
0x01EC	EFRN	7:0	RUD[7:0]						
		15:8	RUD[15:8]						
		23:16	RUD[23:16]						
		31:24			RUD[29:24]				
0x01F0	PEFTSL	7:0	RUD[7:0]						
		15:8	RUD[15:8]						
		23:16	RUD[23:16]						
		31:24	RUD[31:24]						

# SAM D5x/E5x Family Data Sheet

## GMAC - Ethernet MAC

.....continued											
Offset	Name	Bit Pos.									
0x01F4	PEFTN	7:0	RUD[7:0]								
		15:8	RUD[15:8]								
		23:16	RUD[23:16]								
		31:24								RUD[29:24]	
0x01F8	PEFRSL	7:0	RUD[7:0]								
		15:8	RUD[15:8]								
		23:16	RUD[23:16]								
		31:24	RUD[31:24]								
0x01FC	PEFRN	7:0	RUD[7:0]								
		15:8	RUD[15:8]								
		23:16	RUD[23:16]								
		31:24								RUD[29:24]	
0x0200 ... 0x026F	Reserved										
0x0270	RLPITR	7:0	RLPITR[7:0]								
		15:8	RLPITR[15:8]								
		23:16									
		31:24									
0x0274	RLPITI	7:0	RLPITI[7:0]								
		15:8	RLPITI[15:8]								
		23:16	RLPITI[23:16]								
		31:24									
0x0278	TLPITR	7:0	TLPITR[7:0]								
		15:8	TLPITR[15:8]								
		23:16									
		31:24									
0x027C	TLPITI	7:0	RLPITI[7:0]								
		15:8	RLPITI[15:8]								
		23:16	RLPITI[23:16]								
		31:24									

## 24.9 Register Description

### 24.9.1 GMAC Network Control Register

**Name:** NCR  
**Offset:** 0x000  
**Reset:** 0x00000000  
**Property:** -

	31	30	29	28	27	26	25	24			
Access											
Reset											
	23	22	21	20	19	18	17	16			
								LPI	FNP	TXPBPF	ENPBPR
Access					R/W	R/W	R/W	R/W			
Reset					0	0	0	0			
	15	14	13	12	11	10	9	8			
	SRTSM			TXZQPF	TXPF	THALT	TSTART	BP			
Access	R/W			R/W	R/W	R/W	R/W	R/W			
Reset	0			0	0	0	0	0			
	7	6	5	4	3	2	1	0			
	WESTAT	INCSTAT	CLRSTAT	MPE	TXEN	RXEN	LBL				
Access	R/W	R/W	R/W	R/W	R/W	R/W	R/W				
Reset	0	0	0	0	0	0	0				

**Bit 19 – LPI** Low Power Idle Enable

Writing a '1' to this bit will enable low power idle (LPI) transmission, immediately transmitted on txd and tx\_er.

**Bit 18 – FNP** Flush Next Packet

Writing a '1' to this bit will flush the next packet from the external RX DPRAM. Flushing the next packet will only take effect if the DMA is not currently writing a packet already stored in the DPRAM to memory.

**Bit 17 – TXPBPF** Transmit PFC Priority-based Pause Frame

Takes the values stored in the Transmit PFC Pause Register.

**Bit 16 – ENPBPR** Enable PFC Priority-based Pause Reception

Writing a '1' to this bit enables PFC Priority Based Pause Reception capabilities, enabling PFC negotiation and recognition of priority-based pause frames.

Value	Description
0	Normal operation
1	PFC Priority-based Pause frames are recognized

**Bit 15 – SRTSM** Store Receive Time Stamp to Memory

Writing a '1' to this bit causes the CRC of every received frame to be replaced with the value of the nanoseconds field of the 1588 timer that was captured as the receive frame passed the message time stamp point.

Value	Description
0	Normal operation
1	All received frames' CRC is replaced with a time stamp

**Bit 12 – TXZQPF** Transmit Zero Quantum Pause Frame

Writing a '1' to this bit causes a pause frame with zero quantum to be transmitted.

Writing a '0' to this bit has no effect.

**Bit 11 – TXPF** Transmit Pause Frame

Writing one to this bit causes a pause frame to be transmitted.

Writing a '0' to this bit has no effect.

**Bit 10 – THALT** Transmit Halt

Writing a '1' to this bit halts transmission as soon as any ongoing frame transmission ends.

Writing a '0' to this bit has no effect.

**Bit 9 – TSTART** Start Transmission

Writing a '1' to this bit starts transmission.

Writing a '0' to this bit has no effect.

**Bit 8 – BP** Back Pressure

In 10M or 100M half duplex mode, writing a '1' to this bit forces collisions on all received frames. Ignored in gigabit half duplex mode.

Value	Description
0	Frame collisions are not forced
1	Frame collisions are forced in 10M and 100M half duplex mode

**Bit 7 – WESTAT** Write Enable for Statistics Registers

Writing a '1' to this bit makes the statistics registers writable for functional test purposes.

Value	Description
0	Statistics Registers are write-protected
1	Statistics Registers are write-enabled

**Bit 6 – INCSTAT** Increment Statistics Registers

Writing a '1' to this bit increments all Statistics Registers by one for test purposes.

Writing a '0' to this bit has no effect.

This bit will always read '0'.

**Bit 5 – CLRSTAT** Clear Statistics Registers

Writing a '1' to this bit clears the Statistics Registers.

Writing a '0' to this bit has no effect.

This bit will always read '0'.

**Bit 4 – MPE** Management Port Enable

Writing a '1' to this bit enables the Management Port.

Writing a '0' to this bit disables the Management Port, and forces MDIO to high impedance state and MDC to low impedance.

Value	Description
0	Management Port is disabled
1	Management Port is enabled

**Bit 3 – TXEN** Transmit Enable

Writing a '1' to this bit enables the GMAC transmitter to send data.

Writing a '0' to this bit stops transmission immediately, the transmit pipeline and control registers is cleared, and the Transmit Queue Pointer Register will be set to point to the start of the transmit descriptor list.

Value	Description
0	Transmit is disabled
1	Transmit is enabled

**Bit 2 – RXEN** Receive Enable

Writing a '1' to this bit enables the GMAC to receive data.

Writing a '0' to this bit stops frame reception immediately, and the receive pipeline is cleared. The Receive Queue Pointer Register is not affected.

Value	Description
0	Receive is disabled
1	Receive is enabled

**Bit 1 – LBL** Loop Back Local

Writing '1' to this bit connects GTX to GRX, GTXEN to GRXDV, and forces full duplex mode.

GRXCK and GTXCK may malfunction as the GMAC is switched into and out of internal loop back. It is important that receive and transmit circuits have already been disabled when making the switch into and out of internal loop back.

Value	Description
0	Loop back local is disabled
1	Loop back local is enabled

### 24.9.2 GMAC Network Configuration Register

**Name:** NCFGR  
**Offset:** 0x004  
**Reset:** 0x00080000  
**Property:** R/W

	Bit	31	30	29	28	27	26	25	24
			IRXER	RXBP	IPGSEN		IRXFCS	EFRHD	RXCOEN
Access			R/W	R/W	R/W		R/W	R/W	R/W
Reset			0	0	0		0	0	0
	Bit	23	22	21	20	19	18	17	16
		DCPF	DBW[1:0]		CLK[2:0]			RFCS	LFERD
Access		R/W	R/W	R/W	R/W	R/W	R/W	R/W	R/W
Reset		0	0	0	0	1	0	0	0
	Bit	15	14	13	12	11	10	9	8
		RXBUFO[1:0]		PEN	RTY				MAXFS
Access		R/W	R/W	R/W	R/W				R/W
Reset		0	0	0	0				0
	Bit	7	6	5	4	3	2	1	0
		UNIHEN	MTIHEN	NBC	CAF	JFRAME	DNVLAN	FD	SPD
Access		R/W	R/W	R/W	R/W	R/W	R/W	R/W	R/W
Reset		0	0	0	0	0	0	0	0

**Bit 30 – IRXER** Ignore IPG GRXER

When this bit is written to '1', the Receive Error signal (GRXER) has no effect on the GMAC operation when Receive Data Valid signal (GRXDV) is low.

**Bit 29 – RXBP** Receive Bad Preamble

When written to '1', frames with non-standard preamble are not rejected.

**Bit 28 – IPGSEN** IP Stretch Enable

Writing a '1' to this bit allows the transmit IPG to increase above 96 bit times, depending on the previous frame length using the IPG Stretch Register.

**Bit 26 – IRXFCS** Ignore RX FCS

For normal operation this bit must be written to zero.

When this bit is written to '1', frames with FCS/CRC errors will not be rejected. FCS error statistics will still be collected for frames with bad FCS, and FCS status will be recorded in the DMA descriptor of the frame.

**Bit 25 – EFRHD** Enable Frames Received in half-duplex

Writing a '1' to this bit enables frames to be received in half-duplex mode while transmitting.

**Bit 24 – RXCOEN** Receive Checksum Offload Enable

Writing a '1' to this bit enables the receive checksum engine, and frames with bad IP, TCP or UDP checksums are discarded.

**Bit 23 – DCPF** Disable Copy of Pause Frames

Writing a '1' to this bit prevents valid pause frames from being copied to memory. Pause frames are not copied regardless of the state of the Copy All Frames (CAF) bit, whether a hash match is found or whether a type ID match is identified.

If a destination address match is found, the pause frame will be copied to memory. Note that valid pause frames received will still increment pause statistics and pause the transmission of frames, as required.

**Bits 22:21 – DBW[1:0]** Data Bus Width

The default value for this register is 64 bits.

Value	Name	Description
0	DBW32	32-bit data bus width
1	DBW64	64-bit data bus width

**Bits 20:18 – CLK[2:0]** MDC Clock Division

These bits must be set according to MCK speed, and determine the number MCK will be divided by to generate Management Data Clock (MDC). For conformance with the 802.3 specification, MDC must not exceed 2.5MHz.

**Note:** MDC is only active during MDIO read and write operations.

Value	Name	Description
0	MCK_8	MCK divided by 8 (MCK up to 20MHz)
1	MCK_16	MCK divided by 16 (MCK up to 40MHz)
2	MCK_32	MCK divided by 32 (MCK up to 80MHz)
3	MCK_48	MCK divided by 48 (MCK up to 120MHz)
4	MCK_64	MCK divided by 64 (MCK up to 160MHz)
5	MCK_96	MCK divided by 96 (MCK up to 240MHz)

**Bit 17 – RFCS** Remove FCS

Writing this bit to '1' will cause received frames to be written to memory without their frame check sequence (last 4 bytes). The indicated frame length will be reduced by four bytes in this mode.

**Bit 16 – LFERD** Length Field Error Frame Discard

Writing a '1' to this bit discards frames with a measured length shorter than the extracted length field (as indicated by bytes 13 and 14 in a non-VLAN tagged frame). This only applies to frames with a length field less than 0x0600.

**Bits 15:14 – RXBUFO[1:0]** Receive Buffer Offset

These bits determine the number of bytes by which the received data is offset from the start of the receive buffer.

**Bit 13 – PEN** Pause Enable

When written to '1', transmission will pause if a non-zero 802.3 classic pause frame is received and PFC has not been negotiated.

**Bit 12 – RTY** Retry Test

This bit must be written to '0' for normal operation.

When writing a '1' to this bit, the back-off between collisions will always be one slot time. This setting helps testing the too many retries condition. This setting is also useful for pause frame tests by reducing the pause counter's decrement time from "512 bit times" to "every GRXCK cycle".

**Bit 8 – MAXFS** 1536 Maximum Frame Size

Writing a '1' to this bit increases the maximum accepted frame size to 1536 bytes in length. When written to '0', any frame above 1518 bytes in length is rejected.

**Bit 7 – UNIHEN** Unicast Hash Enable

When writing a '1' to this bit, unicast frames will be accepted when the 6-bit hash function of the destination address points to a bit that is set in the Hash Register.

Writing a '0' to this bit disables unicast hashing.

**Bit 6 – MTIHEN** Multicast Hash Enable

When writing a '1' to this bit, multicast frames will be accepted when the 6-bit hash function of the destination address points to a bit that is set in the Hash Register.

Writing a '0' to this bit disables multicast hashing.

**Bit 5 – NBC** No Broadcast

Writing a '1' to this bit will reject frames addressed to the broadcast address 0xFFFFFFFF (all '1').

Writing a '0' to this bit allows broadcasting to 0xFFFFFFFF.

**Bit 4 – CAF** Copy All Frames

When writing a '1' to this bit, all valid frames will be accepted.

**Bit 3 – JFRAME** Jumbo Frame Size

Writing a '1' to this bit enables jumbo frames of up to 10240 bytes to be accepted. The default length is 10240 bytes.

**Bit 2 – DNVLAN** Discard Non-VLAN Frames

Writing a '1' to this bit allows only VLAN-tagged frames to pass to the address matching logic.

Writing a '0' to this bit allows both VLAN\_tagged and untagged frames to pass to the address matching logic.

**Bit 1 – FD** Full Duplex

Writing a '1' enables full duplex operation, so the transmit block ignores the state of collision and carrier sense and allows receive while transmitting.

Writing a '0' disables full duplex operation.

**Bit 0 – SPD** Speed

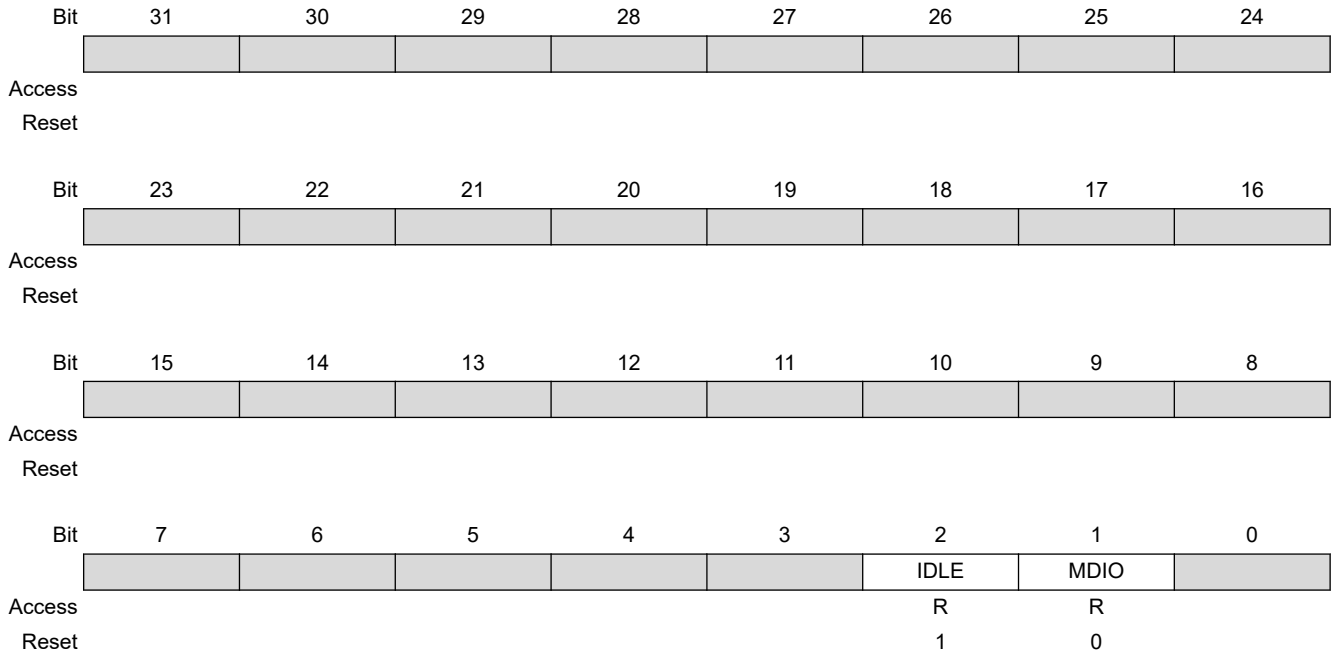
Writing a '1' selects 100Mbps operation.

Writing a '0' to this bit selects 10Mbps operation.



### 24.9.3 GMAC Network Status Register

**Name:** NSR  
**Offset:** 0x008  
**Reset:** 0x00000004  
**Property:** -

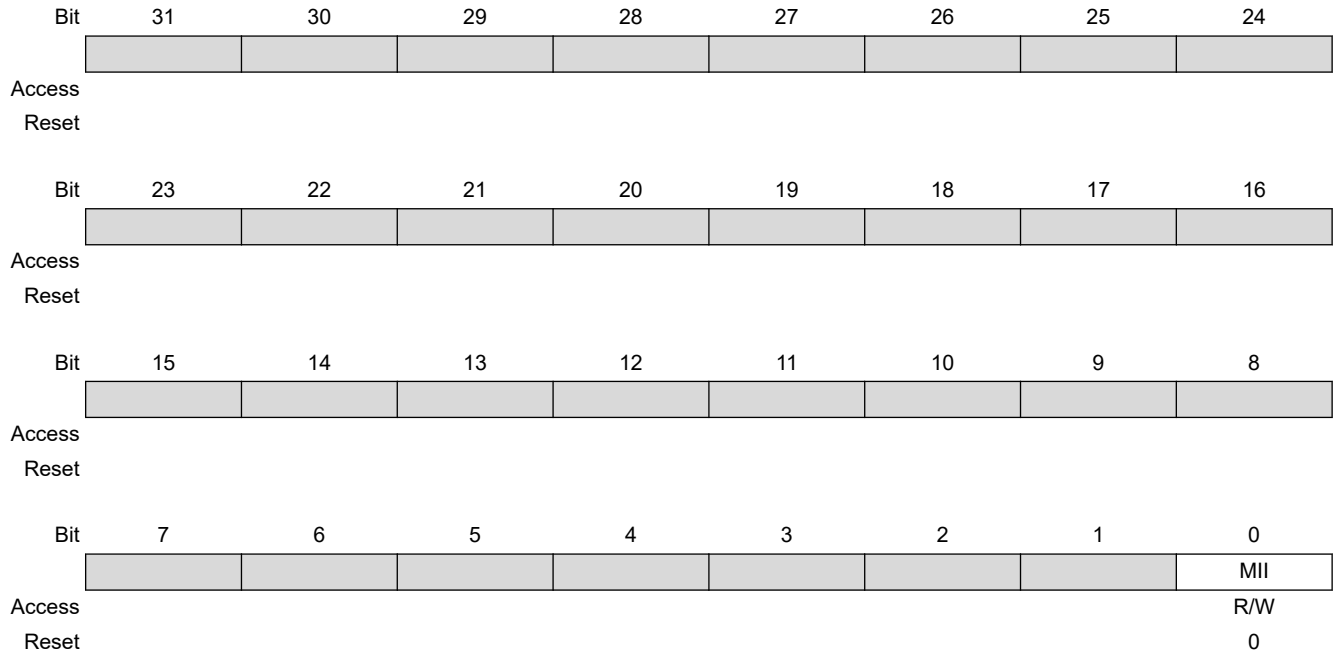


**Bit 2 – IDLE** PHY Management Logic Idle  
 The PHY management logic is idle (i.e., has completed).

**Bit 1 – MDIO** MDIO Input Status  
 Returns status of the MDIO pin.

### 24.9.4 GMAC User Register

**Name:** UR  
**Offset:** 0x00C  
**Reset:** 0x00000000  
**Property:** -



#### Bit 0 – MII Reduced MII Mode

Value	Description
0	RMII mode is selected
1	MII mode is selected

### 24.9.5 GMAC DMA Configuration Register

**Name:** DCFGR  
**Offset:** 0x010  
**Reset:** 0x00020004  
**Property:** Read/Write

	Bit	31	30	29	28	27	26	25	24	
									DDRP	
Access										
Reset									0	
	Bit	23	22	21	20	19	18	17	16	
		DRBS[7:0]								
Access										
Reset		0	0	0	0	0	0	1	0	
	Bit	15	14	13	12	11	10	9	8	
							TXCOEN	TXPBMS	RXBMS[1:0]	
Access										
Reset						0	0	0	0	
	Bit	7	6	5	4	3	2	1	0	
		ESPA	ESMA			FBLDO[4:0]				
Access										
Reset		0	0			0	0	1	0	

#### Bit 24 – DDRP DMA Discard Receive Packets

A write to this bit is ignored if the DMA is not configured in the packet buffer full store and forward mode.

Value	Description
0	Received packets are stored in the SRAM based packet buffer until next AHB buffer resource becomes available.
1	Receive packets from the receiver packet buffer memory are automatically discarded when no AHB resource is available.

#### Bits 23:16 – DRBS[7:0] DMA Receive Buffer Size

These bits defined by these bits determines the size of buffer to use in main AHB system memory when writing received data.

The value is defined in multiples of 64 bytes. For example:

- 0x02: 128 bytes
- 0x18: 1536 bytes (1 × max length frame/buffer)
- 0xA0: 10240 bytes (1 × 10K jumbo frame/buffer)

**⚠ WARNING** Do not write 0x00 to this bit field.

# SAM D5x/E5x Family Data Sheet

## GMAC - Ethernet MAC

Value	Description
0x00	Reserved
0x01-0xFF	1..255 x 64 byte buffer

**Bit 11 – TXCOEN** Transmitter Checksum Generation Offload Enable  
Transmitter IP, TCP and UDP checksum generation offload enable.

Value	Description
0	Frame data is unaffected.
1	The transmitter checksum generation engine calculates and substitutes checksums for transmit frames.

**Bit 10 – TXPBMS** Transmitter Packet Buffer Memory Size Select

When written to zero, the amount of memory used for the transmit packet buffer is reduced by 50%. This reduces the amount of memory used by the GMAC.

It is important to write this bit to '1' if the full configured physical memory is available. The value in parentheses represents the size that would result for the default maximum configured memory size of 4KBytes.

Value	Description
0	Top address bits not used. (2KByte used.)
1	Full configured addressable space (4KBytes) used.

**Bits 9:8 – RXBMS[1:0]** Receiver Packet Buffer Memory Size Select

The default receive packet buffer size is FULL=RECEIVE\_BUFFER\_SIZE Kbytes. The table below shows how to configure this memory to FULL, HALF, QUARTER or EIGHTH of the default size.

Value	Name	Description
0	EIGHTH	RECEIVE_BUFFER_SIZE/8 Kbyte Memory Size
1	QUARTER	RECEIVE_BUFFER_SIZE/4 Kbytes Memory Size
2	HALF	RECEIVE_BUFFER_SIZE/2 Kbytes Memory Size
3	FULL	RECEIVE_BUFFER_SIZE Kbytes Memory Size

**Bit 7 – ESPA** Endian Swap Mode Enable for Packet Data Accesses

Value	Description
0	Little endian mode for AHB transfers selected.
1	Big endian mode for AHB transfers selected.

**Bit 6 – ESMA** Endian Swap Mode Enable for Management Descriptor Accesses

Value	Description
0	Little endian mode for AHB transfers selected.
1	Big endian mode for AHB transfers selected.

**Bits 4:0 – FBLDO[4:0]** Fixed Burst Length for DMA Data Operations

Selects the burst length to attempt to use on the AHB when transferring frame data. Not used for DMA management operations and only used where space and data size allow. Otherwise SINGLE type AHB transfers are used.

One-hot priority encoding enforced automatically on register writes as follows. 'x' represents don't care.

Value	Name	Description
0	-	Reserved
1	SINGLE	00001: Always use SINGLE AHB bursts

# SAM D5x/E5x Family Data Sheet

## GMAC - Ethernet MAC

Value	Name	Description
2	-	Reserved
4	INCR4	001xx: Attempt to use INCR4 AHB bursts (Default)
8	INCR8	01xxx: Attempt to use INCR8 AHB bursts
16	INCR16	1xxxx: Attempt to use INCR16 AHB bursts

### 24.9.6 GMAC Transmit Status Register

**Name:** TSR  
**Offset:** 0x014  
**Reset:** 0x00000000  
**Property:** -

	Bit	31	30	29	28	27	26	25	24
Access									
Reset									
	Bit	23	22	21	20	19	18	17	16
Access									
Reset									
	Bit	15	14	13	12	11	10	9	8
									HRESP
Access									R/W
Reset									0
	Bit	7	6	5	4	3	2	1	0
			UND	TXCOMP	TFC	TXGO	RLE	COL	UBR
Access			R/W	R/W	R/W	R/W	R/W	R/W	R/W
Reset			0	0	0	0	0	0	0

**Bit 8 – HRESP** HRESP Not OK  
 Set when the DMA block sees HRESP not OK.  
 This bit is cleared by writing a '1' to it.

**Bit 6 – UND** Transmit Underrun  
 This bit is set if the transmitter was forced to terminate the transmission of a frame due to further data being unavailable.  
 This bit is also set if a transmitter status write back has not completed when another status write back is attempted.  
 When using the DMA interface configured for internal FIFO mode, this bit is also set when the transmit DMA has written the SOP data into the FIFO and either the AHB bus was not granted in time for further data, or an AHB not OK response was returned, or a used bit was read.  
 This bit is cleared by writing a '1' to it.

**Bit 5 – TXCOMP** Transmit Complete  
 Set when a frame has been transmitted.  
 This bit is cleared by writing a '1' to it.

**Bit 4 – TFC** Transmit Frame Corruption Due to AHB Error  
 This bit is set when an error occurs during reading transmit frame from the AHB. Error causes include HRESP errors and buffers exhausted mid frame. (If the buffers run out during transmission of a frame then transmission stops, FCS shall be bad and GTXER asserted).

In DMA packet buffer mode, this bit is also set if a single frame is too large for the configured packet buffer memory size.

This bit is cleared by writing a '1' to it.

**Bit 3 – TXGO** Transmit Go

This bit is '1' when transmit is active. When using the DMA interface this bit represents the TXGO variable as specified in the transmit buffer description.

**Bit 2 – RLE** Retry Limit Exceeded

This bit is cleared by writing a '1' to it.

**Bit 1 – COL** Collision Occurred

When operating in 10/100Mbps mode, this bit is set by the assertion of either a collision or a late collision. This bit is cleared by writing a '1' to it.

**Bit 0 – UBR** Used Bit Read

This bit is set when a transmit buffer descriptor is read with its used bit set.

This bit is cleared by writing a '1' to it.

### 24.9.7 GMAC Receive Buffer Queue Base Address Register

**Name:** RBQB  
**Offset:** 0x018  
**Reset:** 0x00000000  
**Property:** Read/Write

This register holds the start address of the receive buffer queue (receive buffers descriptor list). The receive buffer queue base address must be initialized before receive is enabled through bit 2 of the Network Control Register. Once reception is enabled, any write to the Receive Buffer Queue Base Address Register is ignored. Reading this register returns the location of the descriptor currently being accessed. This value increments as buffers are used. Software should not use this register for determining where to remove received frames from the queue as it constantly changes as new frames are received. Software should instead work its way through the buffer descriptor queue checking the “used” bits.

In terms of AMBA AHB operation, the descriptors are read from memory using a single 32-bit AHB access. The descriptors should be aligned at 32-bit boundaries and the descriptors are written to using two individual non sequential accesses.

Bit	31	30	29	28	27	26	25	24	
	ADDR[29:22]								
Access	R/W	R/W	R/W	R/W	R/W	R/W	R/W	R/W	
Reset	0	0	0	0	0	0	0	0	
Bit	23	22	21	20	19	18	17	16	
	ADDR[21:14]								
Access	R/W	R/W	R/W	R/W	R/W	R/W	R/W	R/W	
Reset	0	0	0	0	0	0	0	0	
Bit	15	14	13	12	11	10	9	8	
	ADDR[13:6]								
Access	R/W	R/W	R/W	R/W	R/W	R/W	R/W	R/W	
Reset	0	0	0	0	0	0	0	0	
Bit	7	6	5	4	3	2	1	0	
	ADDR[5:0]								
Access	R/W	R/W	R/W	R/W	R/W	R/W			
Reset	0	0	0	0	0	0			

**Bits 31:2 – ADDR[29:0]** Receive Buffer Queue Base Address  
 Written with the address of the start of the receive queue.



# SAM D5x/E5x Family Data Sheet

## GMAC - Ethernet MAC

### 24.9.8 GMAC Transmit Buffer Queue Base Address Register

**Name:** TBQB  
**Offset:** 0x01C  
**Reset:** 0x00000000  
**Property:** -

This register holds the start address of the transmit buffer queue (transmit buffers descriptor list). The Transmit Buffer Queue Base Address Register must be initialized before transmit is started through bit 9 of the Network Control Register. Once transmission has started, any write to the Transmit Buffer Queue Base Address Register is illegal and therefore ignored.

Note that due to clock boundary synchronization, it takes a maximum of four MCK cycles from the writing of the transmit start bit before the transmitter is active. Writing to the Transmit Buffer Queue Base Address Register during this time may produce unpredictable results.

Reading this register returns the location of the descriptor currently being accessed. Since the DMA handles two frames at once, this may not necessarily be pointing to the current frame being transmitted.

In terms of AMBA AHB operation, the descriptors are written to memory using a single 32-bit AHB access. The descriptors should be aligned at 32-bit boundaries and the descriptors are read from memory using two individual non sequential accesses.

Bit	31	30	29	28	27	26	25	24	
	ADDR[29:22]								
Access	R/W	R/W	R/W	R/W	R/W	R/W	R/W	R/W	
Reset	0	0	0	0	0	0	0	0	
Bit	23	22	21	20	19	18	17	16	
	ADDR[21:14]								
Access	R/W	R/W	R/W	R/W	R/W	R/W	R/W	R/W	
Reset	0	0	0	0	0	0	0	0	
Bit	15	14	13	12	11	10	9	8	
	ADDR[13:6]								
Access	R/W	R/W	R/W	R/W	R/W	R/W	R/W	R/W	
Reset	0	0	0	0	0	0	0	0	
Bit	7	6	5	4	3	2	1	0	
	ADDR[5:0]								
Access	R/W	R/W	R/W	R/W	R/W	R/W			
Reset	0	0	0	0	0	0			

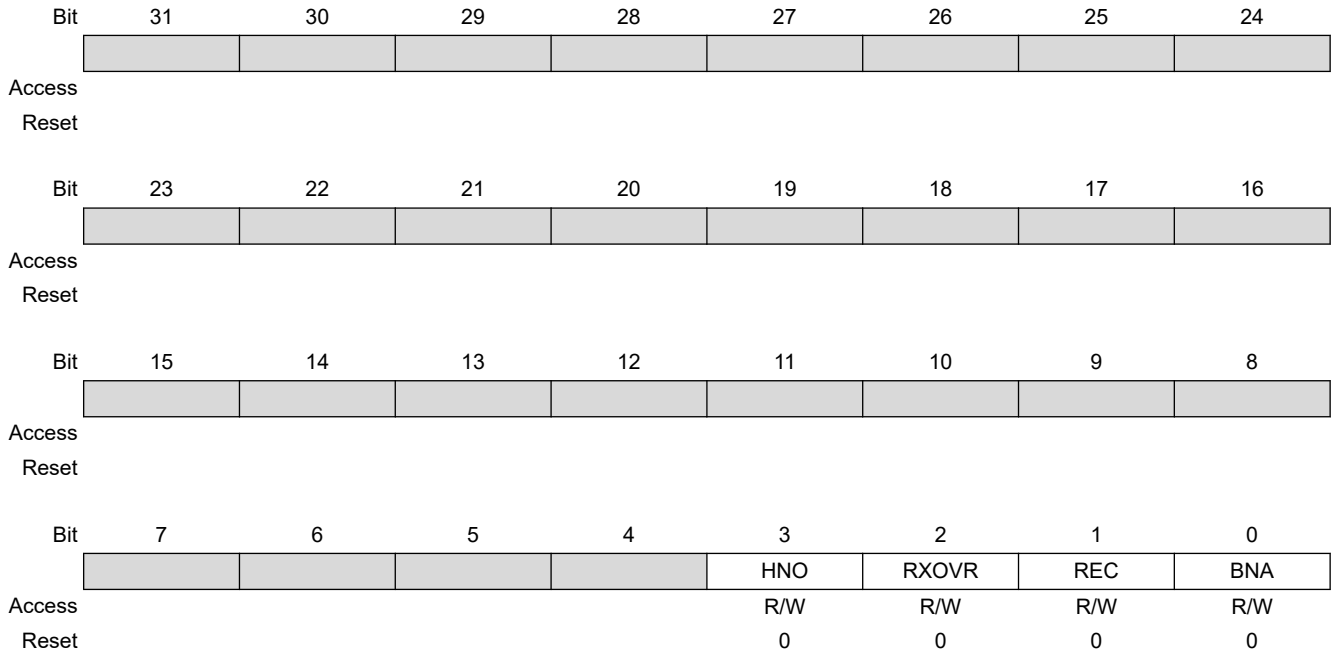
**Bits 31:2 – ADDR[29:0]** Transmit Buffer Queue Base Address

Written with the address of the start of the transmit queue.

### 24.9.9 GMAC Receive Status Register

**Name:** RSR  
**Offset:** 0x020  
**Reset:** 0x00000000  
**Property:** -

This register, when read, provides receive status details. Once read, individual bits may be cleared by writing a '1' to them. It is not possible to set a bit to '1' by writing to this register.



**Bit 3 – HNO** HRESP Not OK

This bit is set when the DMA block sees HRESP not OK.  
 This bit is cleared by writing a '1' to it.

**Bit 2 – RXOVR** Receive Overrun

This bit is set if the receive status was not taken at the end of the frame. The buffer will be recovered if an overrun occurs.  
 This bit is cleared by writing a '1' to it.

**Bit 1 – REC** Frame Received

This bit is set to when one or more frames have been received and placed in memory.  
 This bit is cleared by writing a '1' to it.

**Bit 0 – BNA** Buffer Not Available

When this bit is set, an attempt was made to get a new buffer and the pointer indicated that it was owned by the processor. The DMA will re-read the pointer each time an end of frame is received until a valid pointer is found. This bit is set following each descriptor read attempt that fails, even if consecutive pointers are unsuccessful and software has in the mean time cleared the status flag.  
 This bit is cleared by writing a '1' to it.

### 24.9.10 GMAC Interrupt Status Register

**Name:** ISR  
**Offset:** 0x024  
**Reset:** 0x00000000  
**Property:** -

This register indicates the source of the interrupt. An interrupt source must be enabled in the mask register first so the corresponding bits of this register will be set and the GMAC interrupt signal will be asserted in the system.

Bit	31	30	29	28	27	26	25	24
			TSUCMP	WOL		SRI	PDRSFT	PDRQFT
Access			W	R		R	R	R
Reset			0	0		0	0	0
Bit	23	22	21	20	19	18	17	16
	PDRSFR	PDRQFR	SFT	DRQFT	SFR	DRQFR		
Access	R	R	R	R	R	R		
Reset	0	0	0	0	0	0		
Bit	15	14	13	12	11	10	9	8
		PFTR	PTZ	PFNZ	HRESP	ROVR		
Access		R	R	R	R	R		
Reset		0	0	0	0	0		
Bit	7	6	5	4	3	2	1	0
	TCOMP	TFC	RLEX	TUR	TXUBR	RXUBR	RCOMP	MFS
Access	R	R	R	R	R	R	R	R
Reset	0	0	0	0	0	0	0	0

**Bit 29 – TSUCMP** TSU Timer Comparison  
 Indicates TSU times count and comparison value are equal.

**Bit 28 – WOL** Wake On LAN  
 WOL interrupt. Indicates a WOL message has been received.

**Bit 26 – SRI** TSU Seconds Register Increment  
 Indicates the register has incremented.  
 Cleared on read.

**Bit 25 – PDRSFT** PDelay Response Frame Transmitted  
 Indicates a PTP pdelay\_resp frame has been transmitted.  
 Cleared on read.

**Bit 24 – PDRQFT** PDelay Request Frame Transmitted  
 Indicates a PTP pdelay\_req frame has been transmitted.  
 Cleared on read.

**Bit 23 – PDRSFR** PDelay Response Frame Received  
Indicates a PTP pdelay\_resp frame has been received.  
Cleared on read.

**Bit 22 – PDRQFR** PDelay Request Frame Received  
Indicates a PTP pdelay\_req frame has been received.  
Cleared on read.

**Bit 21 – SFT** PTP Sync Frame Transmitted  
Indicates a PTP sync frame has been transmitted.  
Cleared on read.

**Bit 20 – DRQFT** PTP Delay Request Frame Transmitted  
Indicates a PTP delay\_req frame has been transmitted.  
Cleared on read.

**Bit 19 – SFR** PTP Sync Frame Received  
Indicates a PTP sync frame has been received.  
Cleared on read.

**Bit 18 – DRQFR** PTP Delay Request Frame Received  
Indicates a PTP delay\_req frame has been received.  
Cleared on read.

**Bit 14 – PFTR** Pause Frame Transmitted  
Indicates a pause frame has been successfully transmitted after being initiated from the Network Control Register.  
Cleared on read.

**Bit 13 – PTZ** Pause Time Zero  
Set when either the Pause Time Register at address 0x38 decrements to zero, or when a valid pause frame is received with a zero pause quantum field.  
Cleared on read.

**Bit 12 – PFNZ** Pause Frame with Non-zero Pause Quantum Received  
Indicates a valid pause has been received that has a non-zero pause quantum field.  
Cleared on read.

**Bit 11 – HRESP** HRESP Not OK  
Set when the DMA block sees HRESP not OK.  
Cleared on read.

**Bit 10 – ROVR** Receive Overrun  
Set when the receive overrun status bit is set.  
Cleared on read.

**Bit 7 – TCOMP** Transmit Complete  
Set when a frame has been transmitted.  
Cleared on read.

**Bit 6 – TFC** Transmit Frame Corruption Due to AHB Error

Transmit frame corruption due to AHB error. Set if an error occurs during reading a transmit frame from the AHB, including HRESP errors and buffers exhausted mid frame.

**Bit 5 – RLEX** Retry Limit Exceeded

Retry Limit Exceeded Transmit error.

Cleared on read.

**Bit 4 – TUR** Transmit Underrun

This interrupt is set if the transmitter was forced to terminate an ongoing frame transmission due to further data being unavailable.

This interrupt is also set if a transmitter status write back has not completed when another status write back is attempted.

This interrupt is also set when the transmit DMA has written the SOP data into the FIFO and either the AHB bus was not granted in time for further data, or because an AHB not OK response was returned, or because the used bit was read.

**Bit 3 – TXUBR** TX Used Bit Read

Set when a transmit buffer descriptor is read with its used bit set.

Cleared on read.

**Bit 2 – RXUBR** RX Used Bit Read

Set when a receive buffer descriptor is read with its used bit set.

Cleared on read.

**Bit 1 – RCOMP** Receive Complete

A frame has been stored in memory.

Cleared on read.

**Bit 0 – MFS** Management Frame Sent

The PHY Maintenance Register has completed its operation.

Cleared on read.

### 24.9.11 GMAC Interrupt Enable Register

**Name:** IER  
**Offset:** 0x028  
**Reset:** –  
**Property:** Write-only

This register is write-only and will always return zero.

The following values are valid for all listed bit names of this register:

0: No effect.

1: Enables the corresponding interrupt.

	Bit	31	30	29	28	27	26	25	24
				TSUCMP	WOL		SRI	PDRSFT	PDRQFT
Access				W	W		W	W	W
Reset				–	–		–	–	–
	Bit	23	22	21	20	19	18	17	16
		PDRSFR	PDRQFR	SFT	DRQFT	SFR	DRQFR		
Access		W	W	W	W	W	W		
Reset		–	–	–	–	–	–		
	Bit	15	14	13	12	11	10	9	8
		EXINT	PFTR	PTZ	PFNZ	HRESP	ROVR		
Access		W	W	W	W	W	W		
Reset		–	–	–	–	–	–		
	Bit	7	6	5	4	3	2	1	0
		TCOMP	TFC	RLEX	TUR	TXUBR	RXUBR	RCOMP	MFS
Access		W	W	W	W	W	W	W	W
Reset		–	–	–	–	–	–	–	–

**Bit 29 – TSUCMP** TSU Timer Comparison

**Bit 28 – WOL** Wake On LAN

**Bit 26 – SRI** TSU Seconds Register Increment

**Bit 25 – PDRSFT** PDelay Response Frame Transmitted

**Bit 24 – PDRQFT** PDelay Request Frame Transmitted

**Bit 23 – PDRSFR** PDelay Response Frame Received

**Bit 22 – PDRQFR** PDelay Request Frame Received

**Bit 21 – SFT** PTP Sync Frame Transmitted

**Bit 20 – DRQFT** PTP Delay Request Frame Transmitted

**Bit 19 – SFR** PTP Sync Frame Received

**Bit 18 – DRQFR** PTP Delay Request Frame Received

**Bit 15 – EXINT** External Interrupt

**Bit 14 – PFTR** Pause Frame Transmitted

**Bit 13 – PTZ** Pause Time Zero

**Bit 12 – PFNZ** Pause Frame with Non-zero Pause Quantum Received

**Bit 11 – HRESP** HRESP Not OK

**Bit 10 – ROVR** Receive Overrun

**Bit 7 – TCOMP** Transmit Complete

**Bit 6 – TFC** Transmit Frame Corruption Due to AHB Error

**Bit 5 – RLEX** Retry Limit Exceeded or Late Collision

**Bit 4 – TUR** Transmit Underrun

**Bit 3 – TXUBR** TX Used Bit Read

**Bit 2 – RXUBR** RX Used Bit Read

**Bit 1 – RCOMP** Receive Complete

**Bit 0 – MFS** Management Frame Sent

.  
Cleared on read.

### 24.9.12 GMAC Interrupt Disable Register

**Name:** IDR  
**Offset:** 0x02C  
**Reset:** –  
**Property:** Write-only

This register is write-only and will always return zero.

The following values are valid for all listed bit names of this register:

0: No effect.

1: Disables the corresponding interrupt.

	Bit	31	30	29	28	27	26	25	24
				TSUCMP	WOL	RXLPISBC	SRI	PDRSFT	PDRQFT
Access				W	W	R	W	W	W
Reset				–	–	–	–	–	–
	Bit	23	22	21	20	19	18	17	16
		PDRSFR	PDRQFR	SFT	DRQFT	SFR	DRQFR		
Access		W	W	W	W	W	W		
Reset		–	–	–	–	–	–		
	Bit	15	14	13	12	11	10	9	8
		EXINT	PFTR	PTZ	PFNZ	HRESP	ROVR		
Access		W	W	W	W	W	W		
Reset		–	–	–	–	–	–		
	Bit	7	6	5	4	3	2	1	0
		TCOMP	TFC	RLEX	TUR	TXUBR	RXUBR	RCOMP	MFS
Access		W	W	W	W	W	W	W	W
Reset		–	–	–	–	–	–	–	–

**Bit 29 – TSUCMP** TSU Timer Comparison

**Bit 28 – WOL** Wake On LAN

**Bit 27 – RXLPISBC** Receive LPI indication Status Bit Change  
 Receive LPI indication status bit change.  
 Cleared on read.

**Bit 26 – SRI** TSU Seconds Register Increment

**Bit 25 – PDRSFT** PDelay Response Frame Transmitted

**Bit 24 – PDRQFT** PDelay Request Frame Transmitted

**Bit 23 – PDRSFR** PDelay Response Frame Received

**Bit 22 – PDRQFR** PDelay Request Frame Received



- Bit 21 – SFT** PTP Sync Frame Transmitted
- Bit 20 – DRQFT** PTP Delay Request Frame Transmitted
- Bit 19 – SFR** PTP Sync Frame Received
- Bit 18 – DRQFR** PTP Delay Request Frame Received
- Bit 15 – EXINT** External Interrupt
- Bit 14 – PFTR** Pause Frame Transmitted
- Bit 13 – PTZ** Pause Time Zero
- Bit 12 – PFNZ** Pause Frame with Non-zero Pause Quantum Received
- Bit 11 – HRESP** HRESP Not OK
- Bit 10 – ROVR** Receive Overrun
- Bit 7 – TCOMP** Transmit Complete
- Bit 6 – TFC** Transmit Frame Corruption Due to AHB Error
- Bit 5 – RLEX** Retry Limit Exceeded or Late Collision
- Bit 4 – TUR** Transmit Underrun
- Bit 3 – TXUBR** TX Used Bit Read
- Bit 2 – RXUBR** RX Used Bit Read
- Bit 1 – RCOMP** Receive Complete
- Bit 0 – MFS** Management Frame Sent

### 24.9.13 GMAC Interrupt Mask Register

**Name:** IMR  
**Offset:** 0x030  
**Reset:** 0x07FFFFFFF  
**Property:** -

This register is a read-only register indicating which interrupts are masked. All bits are set at Reset and can be reset individually by writing to the Interrupt Enable Register (IER), or set individually by writing to the Interrupt Disable Register (IDR).

For test purposes there is a write-only function to this register that allows the bits in the Interrupt Status Register to be set or cleared, regardless of the state of the mask register. A write to this register directly affects the state of the corresponding bit in the Interrupt Status Register, causing an interrupt to be generated if a 1 is written.

The following values are valid for all listed bit names of this register when read:

0: The corresponding interrupt is enabled.

1: The corresponding interrupt is not enabled.

Bit	31	30	29	28	27	26	25	24
			TSUCMP	WOL		SRI	PDRSFT	PDRQFT
Access			W	R		R	R	R
Reset			0	0		1	1	1
Bit	23	22	21	20	19	18	17	16
	PDRSFR	PDRQFR	SFT	DRQFT	SFR	DRQFR		
Access	R	R	R	R	R	R		
Reset	1	1	1	1	1	1		
Bit	15	14	13	12	11	10	9	8
	EXINT	PFTR	PTZ	PFNZ	HRESP	ROVR		
Access	R	R	R	R	R	R		
Reset	1	1	1	1	1	1		
Bit	7	6	5	4	3	2	1	0
	TCOMP	TFC	RLEX	TUR	TXUBR	RXUBR	RCOMP	MFS
Access	R	R	R	R	R	R	R	R
Reset	1	1	1	1	1	1	1	1

**Bit 29 – TSUCMP** TSU Timer Comparison  
Indicates TSU times count and comparison value are equal.

**Bit 28 – WOL** Wake On LAN  
WOL interrupt. Indicates a WOL message has been received.

**Bit 26 – SRI** TSU Seconds Register Increment  
Indicates the register has incremented.  
Cleared on read.

- Bit 25 – PDRSFT** PDelay Response Frame Transmitted
- Bit 24 – PDRQFT** PDelay Request Frame Transmitted
- Bit 23 – PDRSFR** PDelay Response Frame Received
- Bit 22 – PDRQFR** PDelay Request Frame Received
- Bit 21 – SFT** PTP Sync Frame Transmitted
- Bit 20 – DRQFT** PTP Delay Request Frame Transmitted
- Bit 19 – SFR** PTP Sync Frame Received
- Bit 18 – DRQFR** PTP Delay Request Frame Received
- Bit 15 – EXINT** External Interrupt
- Bit 14 – PFTR** Pause Frame Transmitted
- Bit 13 – PTZ** Pause Time Zero
- Bit 12 – PFNZ** Pause Frame with Non-zero Pause Quantum Received
- Bit 11 – HRESP** HRESP Not OK
- Bit 10 – ROVR** Receive Overrun
- Bit 7 – TCOMP** Transmit Complete
- Bit 6 – TFC** Transmit Frame Corruption Due to AHB Error
- Bit 5 – RLEX** Retry Limit Exceeded
- Bit 4 – TUR** Transmit Underrun
- Bit 3 – TXUBR** TX Used Bit Read
- Bit 2 – RXUBR** RX Used Bit Read
- Bit 1 – RCOMP** Receive Complete
- Bit 0 – MFS** Management Frame Sent

### 24.9.14 GMAC PHY Maintenance Register

**Name:** MAN  
**Offset:** 0x034  
**Reset:** 0x00000000  
**Property:** Read/Write

This register is a shift register. Writing to it starts a shift operation which is signaled completed when bit 2 is set in the Network Status Register (NSR). It takes about 2000 MCK cycles to complete, when MDC is set for MCK divide by 32 in the Network Configuration Register. An interrupt is generated upon completion.

During this time, the MSB of the register is output on the MDIO pin and the LSB updated from the MDIO pin with each MDC cycle. This causes transmission of a PHY management frame on MDIO. Refer also to section 22.2.4.5 of the IEEE 802.3 standard.

Reading during the shift operation returns the current contents of the shift register. At the end of management operation, the bits will have shifted back to their original locations. For a read operation, the data bits are updated with data read from the PHY. It is important to write the correct values to the register to ensure a valid PHY management frame is produced.

The MDIO interface can read IEEE 802.3 clause 45 PHYs, as well as clause 22 PHYs. To read clause 45 PHYs, bit 30 should be written with a '0' rather than a '1'. To write clause 45 PHYs, bits 31:28 should be written as 0x1:

PHY	Access	Bit Value			
		WZO	CLTTO	OP[1]	OP[0]
Clause 22	Read	0	1	1	0
	Write	0	1	0	1
Clause 45	Read	0	0	1	1
	Write	0	0	0	1
	Read + Address	0	0	1	0

For a description of MDC generation, see also the 'GMAC Network Configuration Register' (NCR) description.

# SAM D5x/E5x Family Data Sheet

## GMAC - Ethernet MAC

Bit	31	30	29	28	27	26	25	24
	WZO	CLTTO	OP[1:0]		PHYA[4:1]			
Access	R/W	R/W	R/W	R/W	R/W	R/W	R/W	R/W
Reset	0	0	0	0	0	0	0	0
Bit	23	22	21	20	19	18	17	16
	PHYA[0:0]		REGA[4:0]				WTN[1:0]	
Access	R/W	R/W	R/W	R/W	R/W	R/W	R/W	R/W
Reset	0	0	0	0	0	0	0	0
Bit	15	14	13	12	11	10	9	8
	DATA[15:8]							
Access	R/W	R/W	R/W	R/W	R/W	R/W	R/W	R/W
Reset	0	0	0	0	0	0	0	0
Bit	7	6	5	4	3	2	1	0
	DATA[7:0]							
Access	R/W	R/W	R/W	R/W	R/W	R/W	R/W	R/W
Reset	0	0	0	0	0	0	0	0

**Bit 31 – WZO** Write ZERO

Must be written to '0'.

Value	Description
0	Mandatory
1	Reserved

**Bit 30 – CLTTO** Clause 22 Operation

Value	Description
0	Clause 45 operation
1	Clause 22 operation

**Bits 29:28 – OP[1:0]** Operation

Value	Description
01	Write
10	Read
Other	Reserved

**Bits 27:23 – PHYA[4:0]** PHY Address

**Bits 22:18 – REGA[4:0]** Register Address

Specifies the register in the PHY to access.

**Bits 17:16 – WTN[1:0]** Write Ten

Must be written to '10'.

Value	Description
10	Mandatory
Other	Reserved

**Bits 15:0 – DATA[15:0]** PHY Data

For a write operation, this field is written with the data to be written to the PHY.

After a read operation, this field contains the data read from the PHY.

### 24.9.15 GMAC Receive Pause Quantum Register

**Name:** RPQ  
**Offset:** 0x038  
**Reset:** 0x00000000  
**Property:** -

	Bit	31	30	29	28	27	26	25	24
		[Bit Field 24:31]							
Access									
Reset									
	Bit	23	22	21	20	19	18	17	16
		[Bit Field 16:23]							
Access									
Reset									
	Bit	15	14	13	12	11	10	9	8
		RPQ[15:8]							
Access		R	R	R	R	R	R	R	R
Reset		0	0	0	0	0	0	0	0
	Bit	7	6	5	4	3	2	1	0
		RPQ[7:0]							
Access		R	R	R	R	R	R	R	R
Reset		0	0	0	0	0	0	0	0

**Bits 15:0 – RPQ[15:0]** Received Pause Quantum

Stores the current value of the Receive Pause Quantum Register which is decremented every 512 bit times.

### 24.9.16 GMAC Transmit Pause Quantum Register

**Name:** TPQ  
**Offset:** 0x03C  
**Reset:** 0x0000FFFF  
**Property:** -

	31	30	29	28	27	26	25	24
Access								
Reset								
	23	22	21	20	19	18	17	16
Access								
Reset								
	15	14	13	12	11	10	9	8
	TPQ[15:8]							
Access	R/W	R/W	R/W	R/W	R/W	R/W	R/W	R/W
Reset	1	1	1	1	1	1	1	1
	7	6	5	4	3	2	1	0
	TPQ[7:0]							
Access	R/W	R/W	R/W	R/W	R/W	R/W	R/W	R/W
Reset	1	1	1	1	1	1	1	1

**Bits 15:0 – TPQ[15:0]** Transmit Pause Quantum  
 Written with the pause quantum value for pause frame transmission.



# SAM D5x/E5x Family Data Sheet

## GMAC - Ethernet MAC

### 24.9.17 GMAC TX Partial Store and Forward Register

**Name:** TPSF  
**Offset:** 0x040  
**Reset:** 0x00000FFF  
**Property:** -

Bit	31	30	29	28	27	26	25	24
	ENTXP							
Access	R/W							
Reset	0							
Bit	23	22	21	20	19	18	17	16
Access								
Reset								
Bit	15	14	13	12	11	10	9	8
					TPB1ADR[11:8]			
Access					R/W	R/W	R/W	R/W
Reset					1	1	1	1
Bit	7	6	5	4	3	2	1	0
	TPB1ADR[7:0]							
Access	R/W	R/W	R/W	R/W	R/W	R/W	R/W	R/W
Reset	1	1	1	1	1	1	1	1

**Bit 31 – ENTXP** Enable TX Partial Store and Forward Operation

**Bits 11:0 – TPB1ADR[11:0]** Transmit Partial Store and Forward Address Watermark value.

# SAM D5x/E5x Family Data Sheet

## GMAC - Ethernet MAC

### 24.9.18 GMAC RX Partial Store and Forward Register

**Name:** RPSF  
**Offset:** 0x044  
**Reset:** 0x00000FFF  
**Property:** -

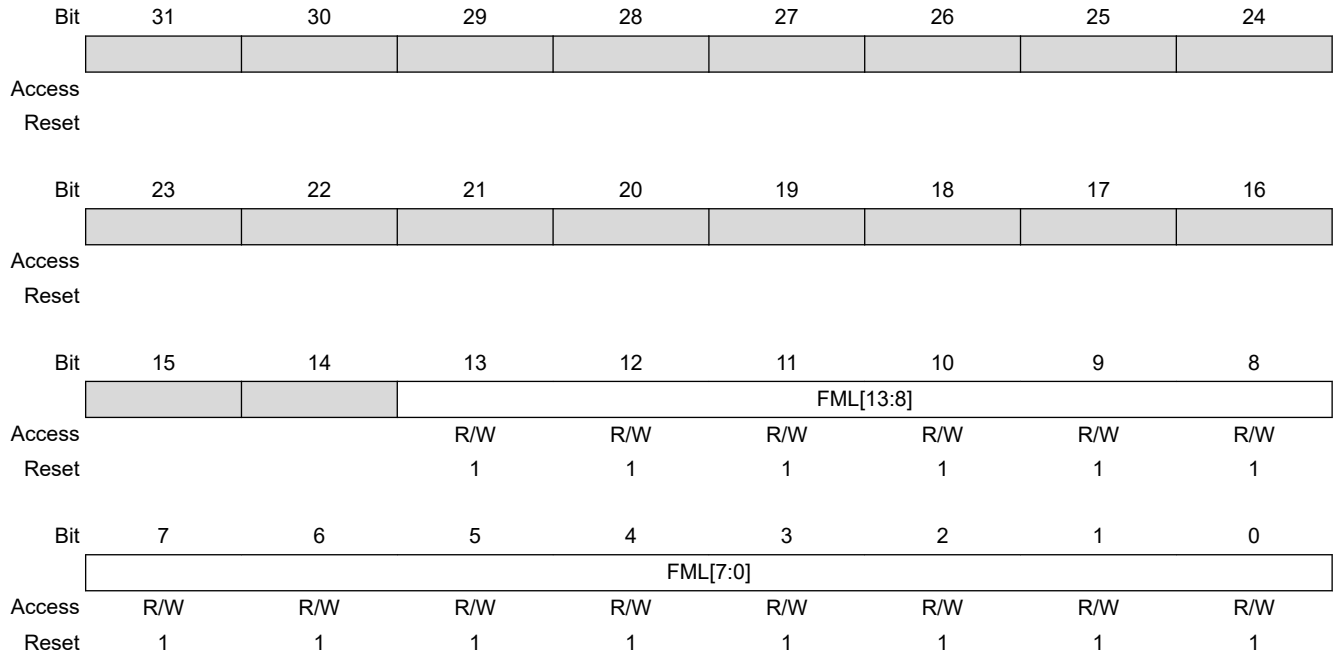
	31	30	29	28	27	26	25	24
	ENRXP							
Access	R							
Reset	0							
	23	22	21	20	19	18	17	16
Access								
Reset								
	15	14	13	12	11	10	9	8
					RPB1ADR[11:8]			
Access					R/W	R/W	R/W	R/W
Reset					1	1	1	1
	7	6	5	4	3	2	1	0
	RPB1ADR[7:0]							
Access	R/W	R/W	R/W	R/W	R/W	R/W	R/W	R/W
Reset	1	1	1	1	1	1	1	1

**Bit 31 – ENRXP** Enable RX Partial Store and Forward Operation

**Bits 11:0 – RPB1ADR[11:0]** Receive Partial Store and Forward Address Watermark value. Reset = 1.

### 24.9.19 GMAC RX Jumbo Frame Max Length Register

**Name:** RJFML  
**Offset:** 0x048  
**Reset:** 0x00003FFF  
**Property:** -



**Bits 13:0 – FML[13:0]** Frame Max Length  
 Rx jumbo frame maximum length.

# SAM D5x/E5x Family Data Sheet

## GMAC - Ethernet MAC

### 24.9.20 GMAC Hash Register Bottom

**Name:** HRB  
**Offset:** 0x080  
**Reset:** 0x00000000  
**Property:** Read/Write

The unicast hash enable (UNIHEN) and the multicast hash enable (MITIHEN) bits in the Network Configuration Register (NCFGR) enable the reception of hash matched frames.

Bit	31	30	29	28	27	26	25	24
ADDR[31:24]								
Access	R/W	R/W	R/W	R/W	R/W	R/W	R/W	R/W
Reset	0	0	0	0	0	0	0	0
Bit	23	22	21	20	19	18	17	16
ADDR[23:16]								
Access	R/W	R/W	R/W	R/W	R/W	R/W	R/W	R/W
Reset	0	0	0	0	0	0	0	0
Bit	15	14	13	12	11	10	9	8
ADDR[15:8]								
Access	R/W	R/W	R/W	R/W	R/W	R/W	R/W	R/W
Reset	0	0	0	0	0	0	0	0
Bit	7	6	5	4	3	2	1	0
ADDR[7:0]								
Access	R/W	R/W	R/W	R/W	R/W	R/W	R/W	R/W
Reset	0	0	0	0	0	0	0	0

**Bits 31:0 – ADDR[31:0]** Hash Address  
 The first 32 bits of the Hash Address Register.

# SAM D5x/E5x Family Data Sheet

## GMAC - Ethernet MAC

### 24.9.21 GMAC Hash Register Top

**Name:** HRT  
**Offset:** 0x084  
**Reset:** 0x00000000  
**Property:** Read/Write

The Unicast Hash Enable (UNIHEN) and the Multicast Hash Enable (MITIHEN) bits in the Network Configuration Register (NCFGR) enable the reception of hash matched frames.

Bit	31	30	29	28	27	26	25	24
ADDR[31:24]								
Access	R/W	R/W	R/W	R/W	R/W	R/W	R/W	R/W
Reset	0	0	0	0	0	0	0	0
Bit	23	22	21	20	19	18	17	16
ADDR[23:16]								
Access	R/W	R/W	R/W	R/W	R/W	R/W	R/W	R/W
Reset	0	0	0	0	0	0	0	0
Bit	15	14	13	12	11	10	9	8
ADDR[15:8]								
Access	R/W	R/W	R/W	R/W	R/W	R/W	R/W	R/W
Reset	0	0	0	0	0	0	0	0
Bit	7	6	5	4	3	2	1	0
ADDR[7:0]								
Access	R/W	R/W	R/W	R/W	R/W	R/W	R/W	R/W
Reset	0	0	0	0	0	0	0	0

**Bits 31:0 – ADDR[31:0]** Hash Address  
 Bits 63 to 32 of the Hash Address Register.

# SAM D5x/E5x Family Data Sheet

## GMAC - Ethernet MAC

### 24.9.22 GMAC Specific Address n Bottom Register

**Name:** SAB  
**Offset:** 0x88 + n\*0x08 [n=0..3]  
**Reset:** 0x00000000  
**Property:** -

The addresses stored in the Specific Address Registers are deactivated at reset or when their corresponding Specific Address Register Bottom is written. They are activated when Specific Address Register Top is written.

Bit	31	30	29	28	27	26	25	24
	ADDR[31:24]							
Access	R/W	R/W	R/W	R/W	R/W	R/W	R/W	R/W
Reset	0	0	0	0	0	0	0	0
Bit	23	22	21	20	19	18	17	16
	ADDR[23:16]							
Access	R/W	R/W	R/W	R/W	R/W	R/W	R/W	R/W
Reset	0	0	0	0	0	0	0	0
Bit	15	14	13	12	11	10	9	8
	ADDR[15:8]							
Access	R/W	R/W	R/W	R/W	R/W	R/W	R/W	R/W
Reset	0	0	0	0	0	0	0	0
Bit	7	6	5	4	3	2	1	0
	ADDR[7:0]							
Access	R/W	R/W	R/W	R/W	R/W	R/W	R/W	R/W
Reset	0	0	0	0	0	0	0	0

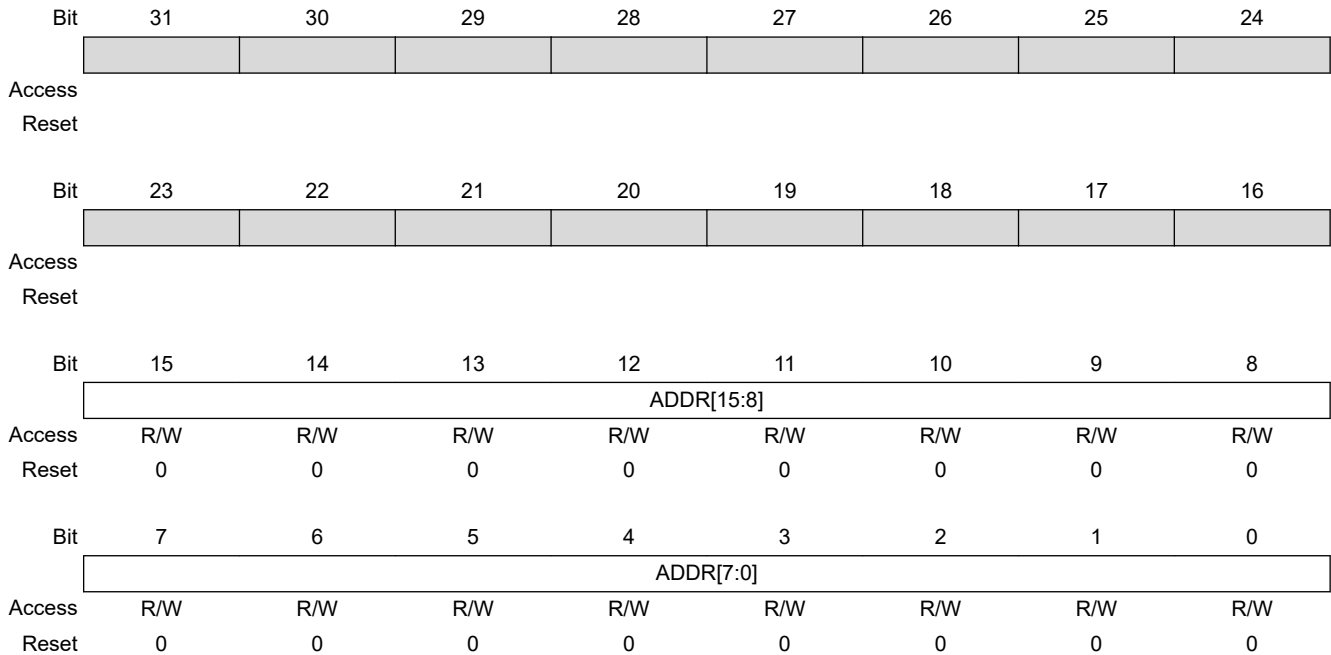
#### Bits 31:0 – ADDR[31:0] Specific Address n

Least significant 32 bits of the destination address, that is, bits 31:0. Bit zero indicates whether the address is multicast or unicast and corresponds to the least significant bit of the first byte received.

### 24.9.23 GMAC Specific Address n Top Register

**Name:** SAT  
**Offset:** 0x8C + n\*0x08 [n=0..3]  
**Reset:** 0x00000000  
**Property:** -

The addresses stored in the Specific Address Registers are deactivated at reset or when their corresponding Specific Address Register Bottom is written. They are activated when Specific Address Register Top is written.

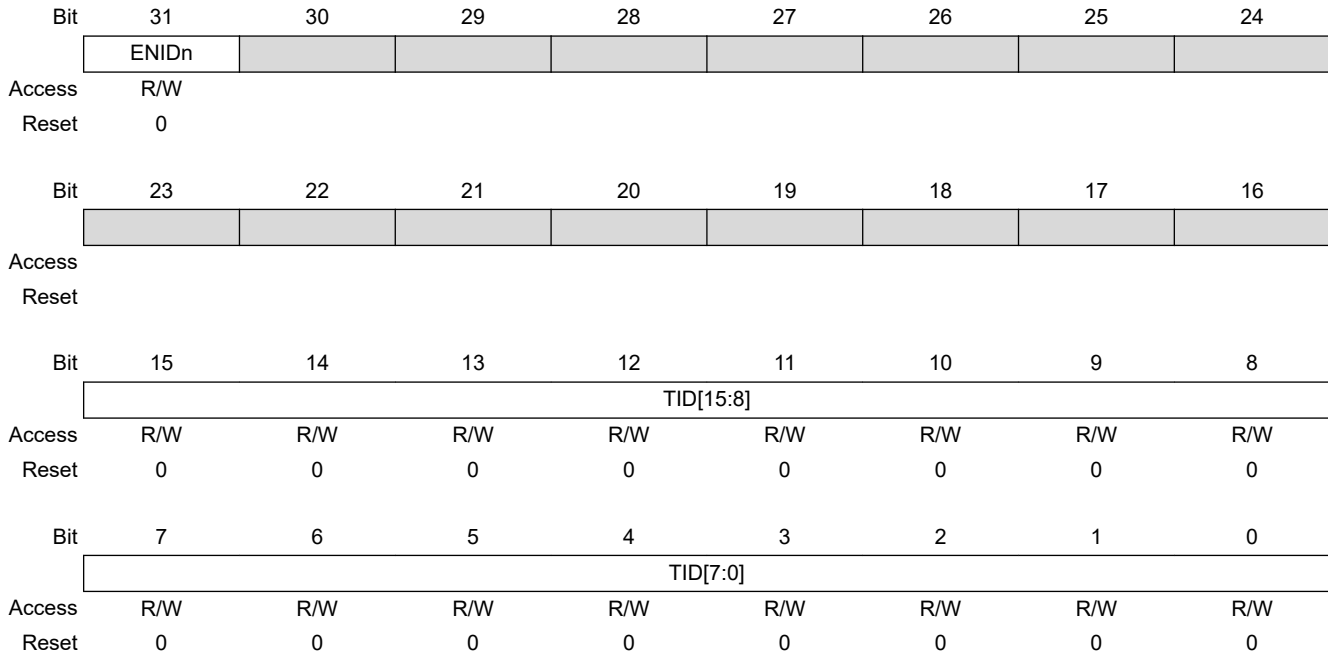


**Bits 15:0 – ADDR[15:0]** Specific Address n

The most significant bits of the destination address, that is, bits 47:32.

### 24.9.24 GMAC Type ID Match n Register

**Name:** TIDM  
**Offset:** 0xA8 + n\*0x04 [n=0..3]  
**Reset:** 0x00000000  
**Property:** -



**Bit 31 – ENIDn** Enable Copying of TID Matched Frames

Value	Description
0	TID n is not part of the comparison match.
1	TID n is processed for the comparison match.

**Bits 15:0 – TID[15:0]** Type ID Match n

For use in comparisons with received frames type ID/length frames.



# SAM D5x/E5x Family Data Sheet

## GMAC - Ethernet MAC

### 24.9.25 GMAC Wake on LAN Register

**Name:** WOL  
**Offset:** 0x0B8  
**Reset:** 0x00000000  
**Property:** -

	31	30	29	28	27	26	25	24
	[Register Bits 31:24]							
Access								
Reset								
	23	22	21	20	19	18	17	16
					MTI	SA1	ARP	MAG
Access					R/W	R/W	R/W	R/W
Reset					0	0	0	0
	15	14	13	12	11	10	9	8
	IP[15:8]							
Access	R/W	R/W	R/W	R/W	R/W	R/W	R/W	R/W
Reset	0	0	0	0	0	0	0	0
	7	6	5	4	3	2	1	0
	IP[7:0]							
Access	R/W	R/W	R/W	R/W	R/W	R/W	R/W	R/W
Reset	0	0	0	0	0	0	0	0

#### Bit 19 – MTI Multicast Hash Event Enable

Value	Description
0	Wake on LAN multicast hash Event disabled
1	Wake on LAN multicast hash Event enabled

#### Bit 18 – SA1 Specific Address Register 1 Event Enable

Value	Description
0	Wake on Specific Address Register 1 Event disabled
1	Wake on Specific Address Register 1 Event enabled

#### Bit 17 – ARP ARP Request Event Enable

Value	Description
0	Wake on LAN ARP request Event disabled
1	Wake on LAN ARP request Event enabled

#### Bit 16 – MAG Magic Packet Event Enable

Value	Description
0	Wake on LAN magic packet Event disabled
1	Wake on LAN magic packet Event enabled

---

**Bits 15:0 – IP[15:0] ARP Request IP Address**

Wake on LAN ARP request IP address. Written to define the 16 least significant bits of the target IP address that is matched to generate a Wake on LAN event.

Value	Description
0x0000	No Event generated, even if matched by the received frame.
0x0001– 0xFFFF	Wake on LAN Event generated for matching LSB of the target IP address.

# SAM D5x/E5x Family Data Sheet

## GMAC - Ethernet MAC

### 24.9.26 GMAC IPG Stretch Register

**Name:** IPGS  
**Offset:** 0x0BC  
**Reset:** 0x00000000  
**Property:** -

Bit	31	30	29	28	27	26	25	24
Access								
Reset								
Bit	23	22	21	20	19	18	17	16
Access								
Reset								
Bit	15	14	13	12	11	10	9	8
	FL[15:8]							
Access	R/W	R/W	R/W	R/W	R/W	R/W	R/W	R/W
Reset	0	0	0	0	0	0	0	0
Bit	7	6	5	4	3	2	1	0
	FL[7:0]							
Access	R/W	R/W	R/W	R/W	R/W	R/W	R/W	R/W
Reset	0	0	0	0	0	0	0	0

**Bits 15:0 – FL[15:0] Frame Length**

Bits FL[7:0] are multiplied with the previously transmitted frame length (including preamble), and divided by FL[15:8]+1 (adding 1 to prevent division by zero).  $RESULT = \frac{FL[7:0]}{F[15+8]+1}$

If RESULT > 96 and the IP Stretch Enable bit in the Network Configuration Register (NCFGR.IPGSEN) is written to '1', RESULT is used for the transmit inter-packet-gap.

### 24.9.27 GMAC Stacked VLAN Register

**Name:** SVLAN  
**Offset:** 0x0C0  
**Reset:** 0x00000000  
**Property:** -

	31	30	29	28	27	26	25	24
	ESVLAN							
Access								
Reset	0							
	23	22	21	20	19	18	17	16
Access								
Reset								
	15	14	13	12	11	10	9	8
	VLAN_TYPE[15:8]							
Access	R/W	R/W	R/W	R/W	R/W	R/W	R/W	R/W
Reset	0	0	0	0	0	0	0	0
	7	6	5	4	3	2	1	0
	VLAN_TYPE[7:0]							
Access	R/W	R/W	R/W	R/W	R/W	R/W	R/W	R/W
Reset	0	0	0	0	0	0	0	0

**Bit 31 – ESVLAN** Enable Stacked VLAN Processing Mode

0: Disable the stacked VLAN processing mode

1: Enable the stacked VLAN processing mode

Value	Description
0	Stacked VLAN Processing disabled
1	Stacked VLAN Processing enabled

**Bits 15:0 – VLAN\_TYPE[15:0]** User Defined VLAN\_TYPE Field

When Stacked VLAN is enabled (ESVLAN=1), the first VLAN tag in a received frame will only be accepted if the VLAN type field is equal to this user defined VLAN\_TYPE, OR equal to the standard VLAN type (0x8100).

**Note:** The second VLAN tag of a Stacked VLAN packet will only be matched correctly if its VLAN\_TYPE field equals 0x8100.

# SAM D5x/E5x Family Data Sheet

## GMAC - Ethernet MAC

### 24.9.28 GMAC Specific Address 1 Mask Bottom

**Name:** SAMB1  
**Offset:** 0x0C8  
**Reset:** 0x00000000  
**Property:** -

	Bit	31	30	29	28	27	26	25	24
		ADDR[31:24]							
Access		R/W	R/W	R/W	R/W	R/W	R/W	R/W	R/W
Reset		0	0	0	0	0	0	0	0
	Bit	23	22	21	20	19	18	17	16
		ADDR[23:16]							
Access		R/W	R/W	R/W	R/W	R/W	R/W	R/W	R/W
Reset		0	0	0	0	0	0	0	0
	Bit	15	14	13	12	11	10	9	8
		ADDR[15:8]							
Access		R/W	R/W	R/W	R/W	R/W	R/W	R/W	R/W
Reset		0	0	0	0	0	0	0	0
	Bit	7	6	5	4	3	2	1	0
		ADDR[7:0]							
Access		R/W	R/W	R/W	R/W	R/W	R/W	R/W	R/W
Reset		0	0	0	0	0	0	0	0

**Bits 31:0 – ADDR[31:0]** Specific Address 1 Mask  
 Setting a bit to '1' masks the corresponding bit in the Specific Address 1 Bottom register (SAB1).

### 24.9.29 GMAC Specific Address Mask 1 Top

**Name:** SAMT1  
**Offset:** 0x0CC  
**Reset:** 0x00000000  
**Property:** -

	Bit	31	30	29	28	27	26	25	24
		[Greyed out bits 31:24]							
Access									
Reset									
	Bit	23	22	21	20	19	18	17	16
		[Greyed out bits 23:16]							
Access									
Reset									
	Bit	15	14	13	12	11	10	9	8
		ADDR[15:8]							
Access		R/W	R/W	R/W	R/W	R/W	R/W	R/W	R/W
Reset		0	0	0	0	0	0	0	0
	Bit	7	6	5	4	3	2	1	0
		ADDR[7:0]							
Access		R/W	R/W	R/W	R/W	R/W	R/W	R/W	R/W
Reset		0	0	0	0	0	0	0	0

**Bits 15:0 – ADDR[15:0]** Specific Address 1 Mask  
 Setting a bit to '1' masks the corresponding bit in the Specific Address 1 register SAT1.

# SAM D5x/E5x Family Data Sheet

## GMAC - Ethernet MAC

### 24.9.30 GMAC 1588 Timer Nanosecond Comparison Register

**Name:** NSC  
**Offset:** 0x0DC  
**Reset:** 0x00000000  
**Property:** -

	31	30	29	28	27	26	25	24
Access								
Reset								
	23	22	21	20	19	18	17	16
				NANOSEC[20:16]				
Access				R/W	R/W	R/W	R/W	R/W
Reset				0	0	0	0	0
	15	14	13	12	11	10	9	8
	NANOSEC[15:8]							
Access	R/W	R/W	R/W	R/W	R/W	R/W	R/W	R/W
Reset	0	0	0	0	0	0	0	0
	7	6	5	4	3	2	1	0
	NANOSEC[7:0]							
Access	R/W	R/W	R/W	R/W	R/W	R/W	R/W	R/W
Reset	0	0	0	0	0	0	0	0

**Bits 20:0 – NANOSEC[20:0]** 1588 Timer Nanosecond Comparison Value  
 Value is compared to the bits [45:24] of the TSU timer count value (upper 21 bits of nanosecond value).

# SAM D5x/E5x Family Data Sheet

## GMAC - Ethernet MAC

### 24.9.31 GMAC 1588 Timer Second Comparison Low Register

**Name:** SCL  
**Offset:** 0x0E0  
**Reset:** 0x00000000  
**Property:** -

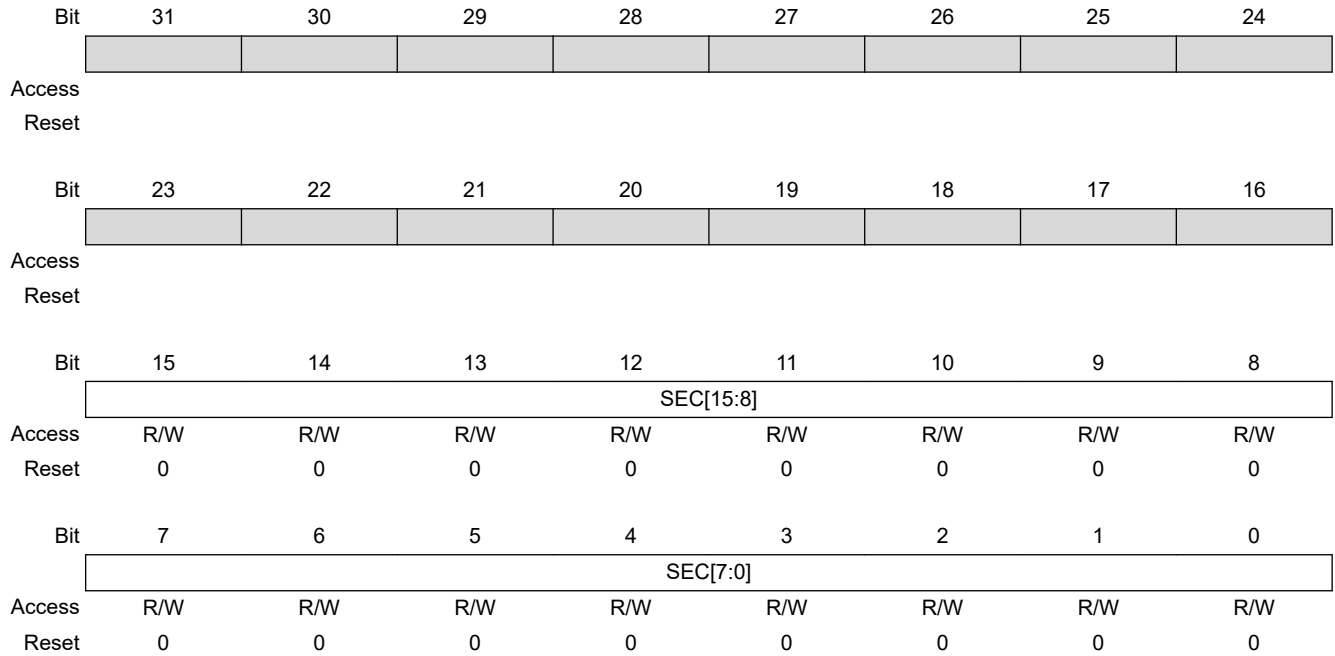
	Bit	31	30	29	28	27	26	25	24
		SEC[31:24]							
Access		R/W	R/W	R/W	R/W	R/W	R/W	R/W	R/W
Reset		0	0	0	0	0	0	0	0
	Bit	23	22	21	20	19	18	17	16
		SEC[23:16]							
Access		R/W	R/W	R/W	R/W	R/W	R/W	R/W	R/W
Reset		0	0	0	0	0	0	0	0
	Bit	15	14	13	12	11	10	9	8
		SEC[15:8]							
Access		R/W	R/W	R/W	R/W	R/W	R/W	R/W	R/W
Reset		0	0	0	0	0	0	0	0
	Bit	7	6	5	4	3	2	1	0
		SEC[7:0]							
Access		R/W	R/W	R/W	R/W	R/W	R/W	R/W	R/W
Reset		0	0	0	0	0	0	0	0

**Bits 31:0 – SEC[31:0]** 1588 Timer Second Comparison Value  
 Value is compared to seconds value bits [31:0] of the TSU timer count value.



### 24.9.32 GMAC 1588 Timer Second Comparison High Register

**Name:** SCH  
**Offset:** 0x0E4  
**Reset:** 0x00000000  
**Property:** -



**Bits 15:0 – SEC[15:0]** 1588 Timer Second Comparison Value

Value is compared to the top 16 bits (most significant 16 bits [47:32] of seconds value) of the TSU timer count value.

# SAM D5x/E5x Family Data Sheet

## GMAC - Ethernet MAC

### 24.9.33 GMAC PTP Event Frame Transmitted Seconds High Register

**Name:** EFTSH  
**Offset:** 0x0E8  
**Reset:** 0x00000000  
**Property:** Read-only

	Bit	31	30	29	28	27	26	25	24
Access									
Reset									
	Bit	23	22	21	20	19	18	17	16
Access									
Reset									
	Bit	15	14	13	12	11	10	9	8
		RUD[15:8]							
Access		R	R	R	R	R	R	R	R
Reset		0	0	0	0	0	0	0	0
	Bit	7	6	5	4	3	2	1	0
		RUD[7:0]							
Access		R	R	R	R	R	R	R	R
Reset		0	0	0	0	0	0	0	0

**Bits 15:0 – RUD[15:0] Register Update**

The register is updated with the value that the IEEE 1588 timer seconds register held when the SFD of a PTP transmit primary event crosses the MII interface. An interrupt is issued when the register is updated.

# SAM D5x/E5x Family Data Sheet

## GMAC - Ethernet MAC

### 24.9.34 GMAC PTP Event Frame Received Seconds High Register

**Name:** EFRSH  
**Offset:** 0x0EC  
**Reset:** 0x00000000  
**Property:** Read-only

	Bit	31	30	29	28	27	26	25	24
		[Register Bits 24-31]							
Access									
Reset									
	Bit	23	22	21	20	19	18	17	16
		[Register Bits 16-23]							
Access									
Reset									
	Bit	15	14	13	12	11	10	9	8
		RUD[15:8]							
Access		R	R	R	R	R	R	R	R
Reset		0	0	0	0	0	0	0	0
	Bit	7	6	5	4	3	2	1	0
		RUD[7:0]							
Access		R	R	R	R	R	R	R	R
Reset		0	0	0	0	0	0	0	0

**Bits 15:0 – RUD[15:0] Register Update**

The register is updated with the value that the IEEE 1588 timer seconds register held when the SFD of a PTP transmit primary event crosses the MII interface. An interrupt is issued when the register is updated.

# SAM D5x/E5x Family Data Sheet

## GMAC - Ethernet MAC

### 24.9.35 GMAC PTP Peer Event Frame Transmitted Seconds High Register

**Name:** PEFTSH  
**Offset:** 0x0F0  
**Reset:** 0x00000000  
**Property:** Read-Only

	Bit	31	30	29	28	27	26	25	24
		[Register Bits 24-31]							
Access									
Reset									
	Bit	23	22	21	20	19	18	17	16
		[Register Bits 16-23]							
Access									
Reset									
	Bit	15	14	13	12	11	10	9	8
		RUD[15:8]							
Access		R	R	R	R	R	R	R	R
Reset		0	0	0	0	0	0	0	0
	Bit	7	6	5	4	3	2	1	0
		RUD[7:0]							
Access		R	R	R	R	R	R	R	R
Reset		0	0	0	0	0	0	0	0

**Bits 15:0 – RUD[15:0] Register Update**

The register is updated with the value that the IEEE 1588 timer seconds register held when the SFD of a PTP transmit peer event crosses the MII interface. An interrupt is issued when the register is updated.

# SAM D5x/E5x Family Data Sheet

## GMAC - Ethernet MAC

### 24.9.36 GMAC PTP Peer Event Frame Received Seconds High Register

**Name:** PEFRSH  
**Offset:** 0x0F4  
**Reset:** 0x00000000  
**Property:** Read-Only

	31	30	29	28	27	26	25	24
Access								
Reset								
	23	22	21	20	19	18	17	16
Access								
Reset								
	15	14	13	12	11	10	9	8
	RUD[15:8]							
Access	R	R	R	R	R	R	R	R
Reset	0	0	0	0	0	0	0	0
	7	6	5	4	3	2	1	0
	RUD[7:0]							
Access	R	R	R	R	R	R	R	R
Reset	0	0	0	0	0	0	0	0

**Bits 15:0 – RUD[15:0] Register Update**

The register is updated with the value that the 1588 timer seconds register held when the SFD of a PTP transmit peer event crosses the MII interface. An interrupt is issued when the register is updated.

# SAM D5x/E5x Family Data Sheet

## GMAC - Ethernet MAC

### 24.9.37 GMAC Octets Transmitted Low Register

**Name:** OTLO  
**Offset:** 0x100  
**Reset:** 0x00000000  
**Property:** Read-Only

When reading the Octets Transmitted and Octets Received Registers, bits [31:0] should be read prior to bits [47:32] to ensure reliable operation.

Bit	31	30	29	28	27	26	25	24
	TXO[31:24]							
Access	R	R	R	R	R	R	R	R
Reset	0	0	0	0	0	0	0	0
Bit	23	22	21	20	19	18	17	16
	TXO[23:16]							
Access	R	R	R	R	R	R	R	R
Reset	0	0	0	0	0	0	0	0
Bit	15	14	13	12	11	10	9	8
	TXO[15:8]							
Access	R	R	R	R	R	R	R	R
Reset	0	0	0	0	0	0	0	0
Bit	7	6	5	4	3	2	1	0
	TXO[7:0]							
Access	R	R	R	R	R	R	R	R
Reset	0	0	0	0	0	0	0	0

#### Bits 31:0 – TXO[31:0] Transmitted Octets

Transmitted octets in valid frames of any type without errors, bits [31:0]. This counter is 48-bits, and is read through two registers. This count does not include octets from automatically generated pause frames.

### 24.9.38 GMAC Octets Transmitted High Register

**Name:** OTHI  
**Offset:** 0x104  
**Reset:** 0x00000000  
**Property:** Read-Only

When reading the Octets Transmitted and Octets Received Registers, bits [31:0] should be read prior to bits [47:32] to ensure reliable operation.

	Bit	31	30	29	28	27	26	25	24
Access									
Reset									
	Bit	23	22	21	20	19	18	17	16
Access									
Reset									
	Bit	15	14	13	12	11	10	9	8
		TXO[15:8]							
Access		R	R	R	R	R	R	R	R
Reset		0	0	0	0	0	0	0	0
	Bit	7	6	5	4	3	2	1	0
		TXO[7:0]							
Access		R	R	R	R	R	R	R	R
Reset		0	0	0	0	0	0	0	0

#### Bits 15:0 – TXO[15:0] Transmitted Octets

Transmitted octets in valid frames of any type without errors, bits [47:32]. This counter is 48-bits, and is read through two registers. This count does not include octets from automatically generated pause frames.

### 24.9.39 GMAC Frames Transmitted

**Name:** FT  
**Offset:** 0x108  
**Reset:** 0x00000000  
**Property:** Read-only

	Bit	31	30	29	28	27	26	25	24
		FTX[31:24]							
Access		R	R	R	R	R	R	R	R
Reset		0	0	0	0	0	0	0	0
	Bit	23	22	21	20	19	18	17	16
		FTX[23:16]							
Access		R	R	R	R	R	R	R	R
Reset		0	0	0	0	0	0	0	0
	Bit	15	14	13	12	11	10	9	8
		FTX[15:8]							
Access		R	R	R	R	R	R	R	R
Reset		0	0	0	0	0	0	0	0
	Bit	7	6	5	4	3	2	1	0
		FTX[7:0]							
Access		R	R	R	R	R	R	R	R
Reset		0	0	0	0	0	0	0	0

**Bits 31:0 – FTX[31:0] Frames Transmitted without Error**

Frames transmitted without error. This register counts the number of frames successfully transmitted, i.e., no underrun and not too many retries. Excludes pause frames.



# SAM D5x/E5x Family Data Sheet

## GMAC - Ethernet MAC

### 24.9.40 GMAC Broadcast Frames Transmitted Register

**Name:** BCFT  
**Offset:** 0x10C  
**Reset:** 0x00000000  
**Property:** Read-only

	Bit	31	30	29	28	27	26	25	24
		BFTX[31:24]							
Access		R	R	R	R	R	R	R	R
Reset		0	0	0	0	0	0	0	0
	Bit	23	22	21	20	19	18	17	16
		BFTX[23:16]							
Access		R	R	R	R	R	R	R	R
Reset		0	0	0	0	0	0	0	0
	Bit	15	14	13	12	11	10	9	8
		BFTX[15:8]							
Access		R	R	R	R	R	R	R	R
Reset		0	0	0	0	0	0	0	0
	Bit	7	6	5	4	3	2	1	0
		BFTX[7:0]							
Access		R	R	R	R	R	R	R	R
Reset		0	0	0	0	0	0	0	0

**Bits 31:0 – BFTX[31:0] Broadcast Frames Transmitted without Error**

This register counts the number of broadcast frames successfully transmitted without error, i.e., no underrun and not too many retries. Excludes pause frames.

# SAM D5x/E5x Family Data Sheet

## GMAC - Ethernet MAC

### 24.9.41 GMAC Multicast Frames Transmitted Register

**Name:** MFT  
**Offset:** 0x110  
**Reset:** 0x00000000  
**Property:** Read-Only

	Bit	31	30	29	28	27	26	25	24
		MFTX[31:24]							
Access		R	R	R	R	R	R	R	R
Reset		0	0	0	0	0	0	0	0
	Bit	23	22	21	20	19	18	17	16
		MFTX[23:16]							
Access		R	R	R	R	R	R	R	R
Reset		0	0	0	0	0	0	0	0
	Bit	15	14	13	12	11	10	9	8
		MFTX[15:8]							
Access		R	R	R	R	R	R	R	R
Reset		0	0	0	0	0	0	0	0
	Bit	7	6	5	4	3	2	1	0
		MFTX[7:0]							
Access		R	R	R	R	R	R	R	R
Reset		0	0	0	0	0	0	0	0

**Bits 31:0 – MFTX[31:0] Multicast Frames Transmitted without Error**

This register counts the number of multicast frames successfully transmitted without error, i.e., no underrun and not too many retries. Excludes pause frames.

### 24.9.42 GMAC Pause Frames Transmitted Register

**Name:** PFT  
**Offset:** 0x114  
**Reset:** 0x00000000  
**Property:** Read-Only

	Bit	31	30	29	28	27	26	25	24
Access									
Reset									
	Bit	23	22	21	20	19	18	17	16
Access									
Reset									
	Bit	15	14	13	12	11	10	9	8
		PFTX[15:8]							
Access		R	R	R	R	R	R	R	R
Reset		0	0	0	0	0	0	0	0
	Bit	7	6	5	4	3	2	1	0
		PFTX[7:0]							
Access		R	R	R	R	R	R	R	R
Reset		0	0	0	0	0	0	0	0

**Bits 15:0 – PFTX[15:0] Pause Frames Transmitted Register**

This register counts the number of pause frames transmitted. Only pause frames triggered by the register interface or through the external pause pins are counted as pause frames. Pause frames received through the FIFO interface are counted in the frames transmitted counter.

# SAM D5x/E5x Family Data Sheet

## GMAC - Ethernet MAC

### 24.9.43 GMAC 64 Byte Frames Transmitted Register

**Name:** BFT64  
**Offset:** 0x118  
**Reset:** 0x00000000  
**Property:** Read-only

	Bit	31	30	29	28	27	26	25	24
		NFTX[31:24]							
Access		R	R	R	R	R	R	R	R
Reset		0	0	0	0	0	0	0	0
	Bit	23	22	21	20	19	18	17	16
		NFTX[23:16]							
Access		R	R	R	R	R	R	R	R
Reset		0	0	0	0	0	0	0	0
	Bit	15	14	13	12	11	10	9	8
		NFTX[15:8]							
Access		R	R	R	R	R	R	R	R
Reset		0	0	0	0	0	0	0	0
	Bit	7	6	5	4	3	2	1	0
		NFTX[7:0]							
Access		R	R	R	R	R	R	R	R
Reset		0	0	0	0	0	0	0	0

**Bits 31:0 – NFTX[31:0]** 64 Byte Frames Transmitted without Error

This register counts the number of 64 byte frames successfully transmitted without error, i.e., no underrun and not too many retries. Excludes pause frames.

# SAM D5x/E5x Family Data Sheet

## GMAC - Ethernet MAC

### 24.9.44 GMAC 65 to 127 Byte Frames Transmitted Register

**Name:** TBFT127  
**Offset:** 0x11C  
**Reset:** 0x00000000  
**Property:** Read-Only

	Bit	31	30	29	28	27	26	25	24
		NFTX[31:24]							
Access		R	R	R	R	R	R	R	R
Reset		0	0	0	0	0	0	0	0
	Bit	23	22	21	20	19	18	17	16
		NFTX[23:16]							
Access		R	R	R	R	R	R	R	R
Reset		0	0	0	0	0	0	0	0
	Bit	15	14	13	12	11	10	9	8
		NFTX[15:8]							
Access		R	R	R	R	R	R	R	R
Reset		0	0	0	0	0	0	0	0
	Bit	7	6	5	4	3	2	1	0
		NFTX[7:0]							
Access		R	R	R	R	R	R	R	R
Reset		0	0	0	0	0	0	0	0

**Bits 31:0 – NFTX[31:0]** 65 to 127 Byte Frames Transmitted without Error

This register counts the number of 65 to 127 byte frames successfully transmitted without error, i.e., no underrun and not too many retries. Excludes pause frames.

# SAM D5x/E5x Family Data Sheet

## GMAC - Ethernet MAC

### 24.9.45 GMAC 128 to 255 Byte Frames Transmitted Register

**Name:** TBFT255  
**Offset:** 0x120  
**Reset:** 0x00000000  
**Property:** Read-Only

	Bit	31	30	29	28	27	26	25	24
		NFTX[31:24]							
Access		R	R	R	R	R	R	R	R
Reset		0	0	0	0	0	0	0	0
	Bit	23	22	21	20	19	18	17	16
		NFTX[23:16]							
Access		R	R	R	R	R	R	R	R
Reset		0	0	0	0	0	0	0	0
	Bit	15	14	13	12	11	10	9	8
		NFTX[15:8]							
Access		R	R	R	R	R	R	R	R
Reset		0	0	0	0	0	0	0	0
	Bit	7	6	5	4	3	2	1	0
		NFTX[7:0]							
Access		R	R	R	R	R	R	R	R
Reset		0	0	0	0	0	0	0	0

**Bits 31:0 – NFTX[31:0]** 128 to 255 Byte Frames Transmitted without Error

This register counts the number of 128 to 255 byte frames successfully transmitted without error, i.e., no underrun and not too many retries.

# SAM D5x/E5x Family Data Sheet

## GMAC - Ethernet MAC

### 24.9.46 GMAC 256 to 511 Byte Frames Transmitted Register

**Name:** TBFT511  
**Offset:** 0x124  
**Reset:** 0x00000000  
**Property:** Read-Only

	Bit	31	30	29	28	27	26	25	24
		NFTX[31:24]							
Access		R	R	R	R	R	R	R	R
Reset		0	0	0	0	0	0	0	0
	Bit	23	22	21	20	19	18	17	16
		NFTX[23:16]							
Access		R	R	R	R	R	R	R	R
Reset		0	0	0	0	0	0	0	0
	Bit	15	14	13	12	11	10	9	8
		NFTX[15:8]							
Access		R	R	R	R	R	R	R	R
Reset		0	0	0	0	0	0	0	0
	Bit	7	6	5	4	3	2	1	0
		NFTX[7:0]							
Access		R	R	R	R	R	R	R	R
Reset		0	0	0	0	0	0	0	0

**Bits 31:0 – NFTX[31:0]** 256 to 511 Byte Frames Transmitted without Error

This register counts the number of 256 to 511 byte frames successfully transmitted without error, i.e., no underrun and not too many retries.

# SAM D5x/E5x Family Data Sheet

## GMAC - Ethernet MAC

### 24.9.47 GMAC 512 to 1023 Byte Frames Transmitted Register

**Name:** TBFT1023  
**Offset:** 0x128  
**Reset:** 0x00000000  
**Property:** Read-Only

	Bit	31	30	29	28	27	26	25	24
		NFTX[31:24]							
Access		R	R	R	R	R	R	R	R
Reset		0	0	0	0	0	0	0	0
	Bit	23	22	21	20	19	18	17	16
		NFTX[23:16]							
Access		R	R	R	R	R	R	R	R
Reset		0	0	0	0	0	0	0	0
	Bit	15	14	13	12	11	10	9	8
		NFTX[15:8]							
Access		R	R	R	R	R	R	R	R
Reset		0	0	0	0	0	0	0	0
	Bit	7	6	5	4	3	2	1	0
		NFTX[7:0]							
Access		R	R	R	R	R	R	R	R
Reset		0	0	0	0	0	0	0	0

**Bits 31:0 – NFTX[31:0]** 512 to 1023 Byte Frames Transmitted without Error

This register counts the number of 512 to 1023 byte frames successfully transmitted without error, i.e., no underrun and not too many retries.



# SAM D5x/E5x Family Data Sheet

## GMAC - Ethernet MAC

### 24.9.48 GMAC 1024 to 1518 Byte Frames Transmitted Register

**Name:** TBFT1518  
**Offset:** 0x12C  
**Reset:** 0x00000000  
**Property:** Read-Only

	Bit	31	30	29	28	27	26	25	24
		NFTX[31:24]							
Access		R	R	R	R	R	R	R	R
Reset		0	0	0	0	0	0	0	0
	Bit	23	22	21	20	19	18	17	16
		NFTX[23:16]							
Access		R	R	R	R	R	R	R	R
Reset		0	0	0	0	0	0	0	0
	Bit	15	14	13	12	11	10	9	8
		NFTX[15:8]							
Access		R	R	R	R	R	R	R	R
Reset		0	0	0	0	0	0	0	0
	Bit	7	6	5	4	3	2	1	0
		NFTX[7:0]							
Access		R	R	R	R	R	R	R	R
Reset		0	0	0	0	0	0	0	0

**Bits 31:0 – NFTX[31:0]** 1024 to 1518 Byte Frames Transmitted without Error

This register counts the number of 1024 to 1518 byte frames successfully transmitted without error, i.e., no underrun and not too many retries.

### 24.9.49 GMAC Greater Than 1518 Byte Frames Transmitted Register

**Name:** GTBFT1518  
**Offset:** 0x130  
**Reset:** 0x00000000  
**Property:** Read-only

	Bit	31	30	29	28	27	26	25	24
		NFTX[31:24]							
Access		R	R	R	R	R	R	R	R
Reset		0	0	0	0	0	0	0	0
	Bit	23	22	21	20	19	18	17	16
		NFTX[23:16]							
Access		R	R	R	R	R	R	R	R
Reset		0	0	0	0	0	0	0	0
	Bit	15	14	13	12	11	10	9	8
		NFTX[15:8]							
Access		R	R	R	R	R	R	R	R
Reset		0	0	0	0	0	0	0	0
	Bit	7	6	5	4	3	2	1	0
		NFTX[7:0]							
Access		R	R	R	R	R	R	R	R
Reset		0	0	0	0	0	0	0	0

**Bits 31:0 – NFTX[31:0]** Greater than 1518 Byte Frames Transmitted without Error

This register counts the number of 1518 or above byte frames successfully transmitted without error i.e., no underrun and not too many retries.

# SAM D5x/E5x Family Data Sheet

## GMAC - Ethernet MAC

### 24.9.50 GMAC Transmit Underruns Register

**Name:** TUR  
**Offset:** 0x134  
**Reset:** 0x00000000  
**Property:** Read-Only

	31	30	29	28	27	26	25	24
Access								
Reset								
	23	22	21	20	19	18	17	16
Access								
Reset								
	15	14	13	12	11	10	9	8
							TXUNR[9:8]	
Access							R	R
Reset							0	0
	7	6	5	4	3	2	1	0
	TXUNR[7:0]							
Access	R	R	R	R	R	R	R	R
Reset	0	0	0	0	0	0	0	0

**Bits 9:0 – TXUNR[9:0]** Transmit Underruns

This register counts the number of frames not transmitted due to a transmit underrun. If this register is incremented then no other statistics register is incremented.

### 24.9.51 GMAC Single Collision Frames Register

**Name:** SCF  
**Offset:** 0x138  
**Reset:** 0x00000000  
**Property:** -

	31	30	29	28	27	26	25	24
Access								
Reset								
	23	22	21	20	19	18	17	16
							SCOL[17:16]	
Access							R	R
Reset							0	0
	15	14	13	12	11	10	9	8
	SCOL[15:8]							
Access	R	R	R	R	R	R	R	R
Reset	0	0	0	0	0	0	0	0
	7	6	5	4	3	2	1	0
	SCOL[7:0]							
Access	R	R	R	R	R	R	R	R
Reset	0	0	0	0	0	0	0	0

**Bits 17:0 – SCOL[17:0] Single Collision**

This register counts the number of frames experiencing a single collision before being successfully transmitted i.e., no underrun.

# SAM D5x/E5x Family Data Sheet

## GMAC - Ethernet MAC

### 24.9.52 GMAC Multiple Collision Frames Register

**Name:** MCF  
**Offset:** 0x13C  
**Reset:** 0x00000000  
**Property:** Read-Only

	31	30	29	28	27	26	25	24
Access								
Reset								
	23	22	21	20	19	18	17	16
							MCOL[17:16]	
Access							R	R
Reset							0	0
	15	14	13	12	11	10	9	8
	MCOL[15:8]							
Access	R	R	R	R	R	R	R	R
Reset	0	0	0	0	0	0	0	0
	7	6	5	4	3	2	1	0
	MCOL[7:0]							
Access	R	R	R	R	R	R	R	R
Reset	0	0	0	0	0	0	0	0

**Bits 17:0 – MCOL[17:0] Multiple Collision**

This register counts the number of frames experiencing between two and fifteen collisions prior to being successfully transmitted, i.e., no underrun and not too many retries.

# SAM D5x/E5x Family Data Sheet

## GMAC - Ethernet MAC

### 24.9.53 GMAC Excessive Collisions Register

**Name:** EC  
**Offset:** 0x140  
**Reset:** 0x00000000  
**Property:** Read-only

	Bit	31	30	29	28	27	26	25	24
Access									
Reset									
	Bit	23	22	21	20	19	18	17	16
Access									
Reset									
	Bit	15	14	13	12	11	10	9	8
								XCOL[9:8]	
Access								R	R
Reset								0	0
	Bit	7	6	5	4	3	2	1	0
Access		R	R	R	R	R	R	R	R
Reset		0	0	0	0	0	0	0	0

**Bits 9:0 – XCOL[9:0] Excessive Collisions**

This register counts the number of frames that failed to be transmitted because they experienced 16 collisions.

# SAM D5x/E5x Family Data Sheet

## GMAC - Ethernet MAC

### 24.9.54 GMAC Late Collisions Register

**Name:** LC  
**Offset:** 0x144  
**Reset:** 0x00000000  
**Property:** Read-Only

	Bit	31	30	29	28	27	26	25	24
Access									
Reset									
	Bit	23	22	21	20	19	18	17	16
Access									
Reset									
	Bit	15	14	13	12	11	10	9	8
								LCOL[9:8]	
Access								R	R
Reset								0	0
	Bit	7	6	5	4	3	2	1	0
		LCOL[7:0]							
Access		R	R	R	R	R	R	R	R
Reset		0	0	0	0	0	0	0	0

**Bits 9:0 – LCOL[9:0] Late Collisions**

This register counts the number of late collisions occurring after the slot time (512 bits) has expired. In 10/100 mode, late collisions are counted twice i.e., both as a collision and a late collision.

### 24.9.55 GMAC Deferred Transmission Frames Register

**Name:** DTF  
**Offset:** 0x148  
**Reset:** 0x00000000  
**Property:** Read-only

	31	30	29	28	27	26	25	24
Access								
Reset								
	23	22	21	20	19	18	17	16
							DEFT[17:16]	
Access							R	R
Reset							0	0
	15	14	13	12	11	10	9	8
	DEFT[15:8]							
Access	R	R	R	R	R	R	R	R
Reset	0	0	0	0	0	0	0	0
	7	6	5	4	3	2	1	0
	DEFT[7:0]							
Access	R	R	R	R	R	R	R	R
Reset	0	0	0	0	0	0	0	0

**Bits 17:0 – DEFT[17:0] Deferred Transmission**

This register counts the number of frames experiencing deferral due to carrier sense being active on their first attempt at transmission. Frames involved in any collision are not counted nor are frames that experienced a transmit underrun.



### 24.9.56 GMAC Carrier Sense Errors Register

**Name:** CSE  
**Offset:** 0x14C  
**Reset:** 0x00000000  
**Property:** Read-only

	31	30	29	28	27	26	25	24
Access								
Reset								
	23	22	21	20	19	18	17	16
Access								
Reset								
	15	14	13	12	11	10	9	8
							CSR[9:8]	
Access							R	R
Reset							0	0
	7	6	5	4	3	2	1	0
	CSR[7:0]							
Access	R	R	R	R	R	R	R	R
Reset	0	0	0	0	0	0	0	0

**Bits 9:0 – CSR[9:0] Carrier Sense Error**

This register counts the number of frames transmitted with carrier sense was not seen during transmission or where carrier sense was de-asserted after being asserted in a transmit frame without collision (no underrun). Only incremented in half duplex mode. The only effect of a carrier sense error is to increment this register. The behavior of the other statistics registers is unaffected by the detection of a carrier sense error.

### 24.9.57 GMAC Octets Received Low Register

**Name:** ORLO  
**Offset:** 0x150  
**Reset:** 0x00000000  
**Property:** Read-Only

When reading the Octets Transmitted and Octets Received Registers, bits [31:0] should be read prior to bits [47:32] to ensure reliable operation.

Bit	31	30	29	28	27	26	25	24
	RXO[31:24]							
Access	R	R	R	R	R	R	R	R
Reset	0	0	0	0	0	0	0	0
Bit	23	22	21	20	19	18	17	16
	RXO[23:16]							
Access	R	R	R	R	R	R	R	R
Reset	0	0	0	0	0	0	0	0
Bit	15	14	13	12	11	10	9	8
	RXO[15:8]							
Access	R	R	R	R	R	R	R	R
Reset	0	0	0	0	0	0	0	0
Bit	7	6	5	4	3	2	1	0
	RXO[7:0]							
Access	R	R	R	R	R	R	R	R
Reset	0	0	0	0	0	0	0	0

**Bits 31:0 – RXO[31:0]** Received Octets

Received octets in frame without errors [31:0]. The number of octets received in valid frames of any type. This counter is 48-bits and is read through two registers. This count does not include octets from pause frames, and is only incremented if the frame is successfully filtered and copied to memory.

### 24.9.58 GMAC Octets Received High Register

**Name:** ORHI  
**Offset:** 0x154  
**Reset:** 0x00000000  
**Property:** Read-only

When reading the Octets Transmitted and Octets Received Registers, bits 31:0 should be read prior to bits 47:32 to ensure reliable operation.

	Bit	31	30	29	28	27	26	25	24
Access									
Reset									
	Bit	23	22	21	20	19	18	17	16
Access									
Reset									
	Bit	15	14	13	12	11	10	9	8
		RXO[15:8]							
Access		R	R	R	R	R	R	R	R
Reset		0	0	0	0	0	0	0	0
	Bit	7	6	5	4	3	2	1	0
		RXO[7:0]							
Access		R	R	R	R	R	R	R	R
Reset		0	0	0	0	0	0	0	0

**Bits 15:0 – RXO[15:0] Received Octets**

Received octets in frame without errors [47:32]. The number of octets received in valid frames of any type. This counter is 48-bits and is read through two registers. This count does not include octets from pause frames, and is only incremented if the frame is successfully filtered and copied to memory.

# SAM D5x/E5x Family Data Sheet

## GMAC - Ethernet MAC

### 24.9.59 GMAC Frames Received Register

**Name:** FR  
**Offset:** 0x158  
**Reset:** 0x00000000  
**Property:** Read-only

	31	30	29	28	27	26	25	24
	FRX[31:24]							
Access	R	R	R	R	R	R	R	R
Reset	0	0	0	0	0	0	0	0
	FRX[23:16]							
	23	22	21	20	19	18	17	16
Access	R	R	R	R	R	R	R	R
Reset	0	0	0	0	0	0	0	0
	FRX[15:8]							
	15	14	13	12	11	10	9	8
Access	R	R	R	R	R	R	R	R
Reset	0	0	0	0	0	0	0	0
	FRX[7:0]							
	7	6	5	4	3	2	1	0
Access	R	R	R	R	R	R	R	R
Reset	0	0	0	0	0	0	0	0

**Bits 31:0 – FRX[31:0] Frames Received without Error**

This bit field counts the number of frames successfully received, excluding pause frames. It is only incremented if the frame is successfully filtered and copied to memory.

# SAM D5x/E5x Family Data Sheet

## GMAC - Ethernet MAC

### 24.9.60 GMAC Broadcast Frames Received Register

**Name:** BCFR  
**Offset:** 0x15C  
**Reset:** 0x00000000  
**Property:** Read-only

Bit	31	30	29	28	27	26	25	24
	BFRX[31:24]							
Access	R	R	R	R	R	R	R	R
Reset	0	0	0	0	0	0	0	0
Bit	23	22	21	20	19	18	17	16
	BFRX[23:16]							
Access	R	R	R	R	R	R	R	R
Reset	0	0	0	0	0	0	0	0
Bit	15	14	13	12	11	10	9	8
	BFRX[15:8]							
Access	R	R	R	R	R	R	R	R
Reset	0	0	0	0	0	0	0	0
Bit	7	6	5	4	3	2	1	0
	BFRX[7:0]							
Access	R	R	R	R	R	R	R	R
Reset	0	0	0	0	0	0	0	0

**Bits 31:0 – BFRX[31:0]** Broadcast Frames Received without Error

Broadcast frames received without error. This bit field counts the number of broadcast frames successfully received. This excludes pause frames, and is only incremented if the frame is successfully filtered and copied to memory.

# SAM D5x/E5x Family Data Sheet

## GMAC - Ethernet MAC

### 24.9.61 GMAC Multicast Frames Received Register

**Name:** MFR  
**Offset:** 0x160  
**Reset:** 0x00000000  
**Property:** Read-only

Bit	31	30	29	28	27	26	25	24
MFRX[31:24]								
Access	R	R	R	R	R	R	R	R
Reset	0	0	0	0	0	0	0	0
Bit	23	22	21	20	19	18	17	16
MFRX[23:16]								
Access	R	R	R	R	R	R	R	R
Reset	0	0	0	0	0	0	0	0
Bit	15	14	13	12	11	10	9	8
MFRX[15:8]								
Access	R	R	R	R	R	R	R	R
Reset	0	0	0	0	0	0	0	0
Bit	7	6	5	4	3	2	1	0
MFRX[7:0]								
Access	R	R	R	R	R	R	R	R
Reset	0	0	0	0	0	0	0	0

**Bits 31:0 – MFRX[31:0]** Multicast Frames Received without Error

This register counts the number of multicast frames successfully received without error, excluding pause frames, and is only incremented if the frame is successfully filtered and copied to memory.

### 24.9.62 GMAC Pause Frames Received Register

**Name:** PFR  
**Offset:** 0x164  
**Reset:** 0x00000000  
**Property:** Read-Only

	Bit	31	30	29	28	27	26	25	24
Access									
Reset									
	Bit	23	22	21	20	19	18	17	16
Access									
Reset									
	Bit	15	14	13	12	11	10	9	8
		PFRX[15:8]							
Access		R	R	R	R	R	R	R	R
Reset		0	0	0	0	0	0	0	0
	Bit	7	6	5	4	3	2	1	0
		PFRX[7:0]							
Access		R	R	R	R	R	R	R	R
Reset		0	0	0	0	0	0	0	0

**Bits 15:0 – PFRX[15:0]** Pause Frames Received Register  
 This register counts the number of pause frames received without error.

# SAM D5x/E5x Family Data Sheet

## GMAC - Ethernet MAC

### 24.9.63 GMAC 64 Byte Frames Received Register

**Name:** BFR64  
**Offset:** 0x168  
**Reset:** 0x00000000  
**Property:** Read-only

	Bit	31	30	29	28	27	26	25	24
		NFRX[31:24]							
Access		R	R	R	R	R	R	R	R
Reset		0	0	0	0	0	0	0	0
	Bit	23	22	21	20	19	18	17	16
		NFRX[23:16]							
Access		R	R	R	R	R	R	R	R
Reset		0	0	0	0	0	0	0	0
	Bit	15	14	13	12	11	10	9	8
		NFRX[15:8]							
Access		R	R	R	R	R	R	R	R
Reset		0	0	0	0	0	0	0	0
	Bit	7	6	5	4	3	2	1	0
		NFRX[7:0]							
Access		R	R	R	R	R	R	R	R
Reset		0	0	0	0	0	0	0	0

**Bits 31:0 – NFRX[31:0]** 64 Byte Frames Received without Error

This bit field counts the number of 64 byte frames successfully received without error. Excludes pause frames, and is only incremented if the frame is successfully filtered and copied to memory.



# SAM D5x/E5x Family Data Sheet

## GMAC - Ethernet MAC

### 24.9.64 GMAC 65 to 127 Byte Frames Received Register

**Name:** TBFR127  
**Offset:** 0x16C  
**Reset:** 0x00000000  
**Property:** Read-Only

	Bit	31	30	29	28	27	26	25	24
		NFRX[31:24]							
Access		R	R	R	R	R	R	R	R
Reset		0	0	0	0	0	0	0	0
	Bit	23	22	21	20	19	18	17	16
		NFRX[23:16]							
Access		R	R	R	R	R	R	R	R
Reset		0	0	0	0	0	0	0	0
	Bit	15	14	13	12	11	10	9	8
		NFRX[15:8]							
Access		R	R	R	R	R	R	R	R
Reset		0	0	0	0	0	0	0	0
	Bit	7	6	5	4	3	2	1	0
		NFRX[7:0]							
Access		R	R	R	R	R	R	R	R
Reset		0	0	0	0	0	0	0	0

**Bits 31:0 – NFRX[31:0]** 65 to 127 Byte Frames Received without Error

This bit field counts the number of 65 to 127 byte frames successfully received without error. Excludes pause frames, and is only incremented if the frame is successfully filtered and copied to memory.

# SAM D5x/E5x Family Data Sheet

## GMAC - Ethernet MAC

### 24.9.65 GMAC 128 to 255 Byte Frames Received Register

**Name:** TBFR255  
**Offset:** 0x170  
**Reset:** 0x00000000  
**Property:** Read-Only

	Bit	31	30	29	28	27	26	25	24
		NFRX[31:24]							
Access		R	R	R	R	R	R	R	R
Reset		0	0	0	0	0	0	0	0
	Bit	23	22	21	20	19	18	17	16
		NFRX[23:16]							
Access		R	R	R	R	R	R	R	R
Reset		0	0	0	0	0	0	0	0
	Bit	15	14	13	12	11	10	9	8
		NFRX[15:8]							
Access		R	R	R	R	R	R	R	R
Reset		0	0	0	0	0	0	0	0
	Bit	7	6	5	4	3	2	1	0
		NFRX[7:0]							
Access		R	R	R	R	R	R	R	R
Reset		0	0	0	0	0	0	0	0

**Bits 31:0 – NFRX[31:0]** 128 to 255 Byte Frames Received without Error

This bit field counts the number of 128 to 255 byte frames successfully received without error. Excludes pause frames, and is only incremented if the frame is successfully filtered and copied to memory.

# SAM D5x/E5x Family Data Sheet

## GMAC - Ethernet MAC

### 24.9.66 GMAC 256 to 511 Byte Frames Received Register

**Name:** TBFR511  
**Offset:** 0x174  
**Reset:** 0x00000000  
**Property:** Read-Only

Bit	31	30	29	28	27	26	25	24
	NFRX[31:24]							
Access	R	R	R	R	R	R	R	R
Reset	0	0	0	0	0	0	0	0
Bit	23	22	21	20	19	18	17	16
	NFRX[23:16]							
Access	R	R	R	R	R	R	R	R
Reset	0	0	0	0	0	0	0	0
Bit	15	14	13	12	11	10	9	8
	NFRX[15:8]							
Access	R	R	R	R	R	R	R	R
Reset	0	0	0	0	0	0	0	0
Bit	7	6	5	4	3	2	1	0
	NFRX[7:0]							
Access	R	R	R	R	R	R	R	R
Reset	0	0	0	0	0	0	0	0

**Bits 31:0 – NFRX[31:0]** 256 to 511 Byte Frames Received without Error

This bit fields counts the number of 256 to 511 byte frames successfully received without error. Excludes pause frames, and is only incremented if the frame is successfully filtered and copied to memory.

# SAM D5x/E5x Family Data Sheet

## GMAC - Ethernet MAC

### 24.9.67 GMAC 512 to 1023 Byte Frames Received Register

**Name:** TBFR1023  
**Offset:** 0x178  
**Reset:** 0x00000000  
**Property:** Read-Only

	Bit	31	30	29	28	27	26	25	24
		NFRX[31:24]							
Access		R	R	R	R	R	R	R	R
Reset		0	0	0	0	0	0	0	0
	Bit	23	22	21	20	19	18	17	16
		NFRX[23:16]							
Access		R	R	R	R	R	R	R	R
Reset		0	0	0	0	0	0	0	0
	Bit	15	14	13	12	11	10	9	8
		NFRX[15:8]							
Access		R	R	R	R	R	R	R	R
Reset		0	0	0	0	0	0	0	0
	Bit	7	6	5	4	3	2	1	0
		NFRX[7:0]							
Access		R	R	R	R	R	R	R	R
Reset		0	0	0	0	0	0	0	0

**Bits 31:0 – NFRX[31:0]** 512 to 1023 Byte Frames Received without Error

This bit field counts the number of 512 to 1023 byte frames successfully received without error. Excludes pause frames, and is only incremented if the frame is successfully filtered and copied to memory.

# SAM D5x/E5x Family Data Sheet

## GMAC - Ethernet MAC

### 24.9.68 GMAC 1024 to 1518 Byte Frames Received Register

**Name:** TBFR1518  
**Offset:** 0x17C  
**Reset:** 0x00000000  
**Property:** Read-Only

	Bit	31	30	29	28	27	26	25	24
		NFRX[31:24]							
Access		R	R	R	R	R	R	R	R
Reset		0	0	0	0	0	0	0	0
	Bit	23	22	21	20	19	18	17	16
		NFRX[23:16]							
Access		R	R	R	R	R	R	R	R
Reset		0	0	0	0	0	0	0	0
	Bit	15	14	13	12	11	10	9	8
		NFRX[15:8]							
Access		R	R	R	R	R	R	R	R
Reset		0	0	0	0	0	0	0	0
	Bit	7	6	5	4	3	2	1	0
		NFRX[7:0]							
Access		R	R	R	R	R	R	R	R
Reset		0	0	0	0	0	0	0	0

**Bits 31:0 – NFRX[31:0]** 1024 to 1518 Byte Frames Received without Error

This bit field counts the number of 1024 to 1518 byte frames successfully received without error, i.e., no underrun and not too many retries.

# SAM D5x/E5x Family Data Sheet

## GMAC - Ethernet MAC

### 24.9.69 GMAC 1519 to Maximum Byte Frames Received Register

**Name:** TMXBFR  
**Offset:** 0x180  
**Reset:** 0x00000000  
**Property:** Read-Only

Bit	31	30	29	28	27	26	25	24
NFRX[31:24]								
Access	R	R	R	R	R	R	R	R
Reset	0	0	0	0	0	0	0	0
Bit	23	22	21	20	19	18	17	16
NFRX[23:16]								
Access	R	R	R	R	R	R	R	R
Reset	0	0	0	0	0	0	0	0
Bit	15	14	13	12	11	10	9	8
NFRX[15:8]								
Access	R	R	R	R	R	R	R	R
Reset	0	0	0	0	0	0	0	0
Bit	7	6	5	4	3	2	1	0
NFRX[7:0]								
Access	R	R	R	R	R	R	R	R
Reset	0	0	0	0	0	0	0	0

**Bits 31:0 – NFRX[31:0]** 1519 to Maximum Byte Frames Received without Error

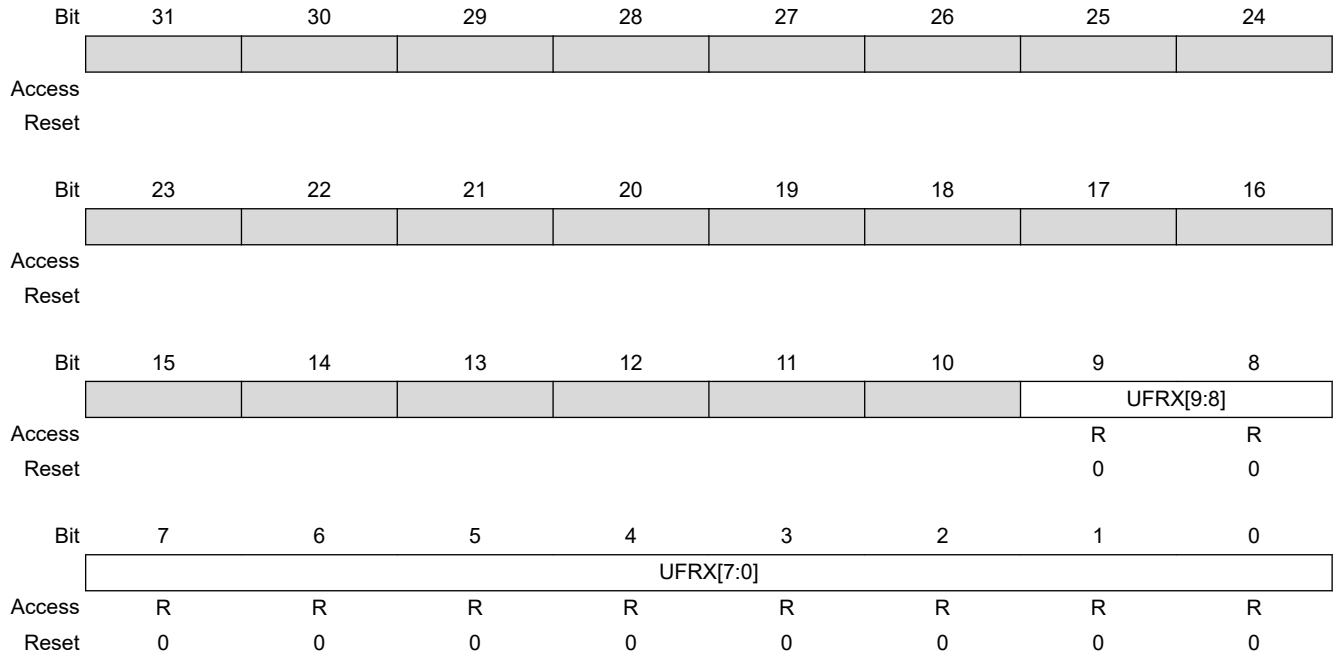
This bit field counts the number of 1519 Byte or above frames successfully received without error. Maximum frame size is determined by the Maximum Frame Size bit (MAXFS, 1536 Bytes) or Jumbo Frame Size bit (JFRAME, 10240 Bytes) in the Network Configuration Register (NCFGFR). Excludes pause frames, and is only incremented if the frame is successfully filtered and copied to memory.

# SAM D5x/E5x Family Data Sheet

## GMAC - Ethernet MAC

### 24.9.70 GMAC Undersized Frames Received Register

**Name:** UFR  
**Offset:** 0x184  
**Reset:** 0x00000000  
**Property:** Read-Only



**Bits 9:0 – UFRX[9:0] Undersize Frames Received**

This bit field counts the number of frames received less than 64 bytes in length (10/100 mode, full duplex) that do not have either a CRC error or an alignment error.

# SAM D5x/E5x Family Data Sheet

## GMAC - Ethernet MAC

### 24.9.71 GMAC Oversized Frames Received Register

**Name:** OFR  
**Offset:** 0x188  
**Reset:** 0x00000000  
**Property:** Read-Only

	Bit	31	30	29	28	27	26	25	24
Access									
Reset									
	Bit	23	22	21	20	19	18	17	16
Access									
Reset									
	Bit	15	14	13	12	11	10	9	8
								OFRX[9:8]	
Access								R	R
Reset								0	0
	Bit	7	6	5	4	3	2	1	0
Access		R	R	R	R	R	R	R	R
Reset		0	0	0	0	0	0	0	0

**Bits 9:0 – OFRX[9:0]** Oversized Frames Received

This bit field counts the number of frames received exceeding 1518 Bytes in length (1536 Bytes if NCFGGR.MAXFSS is written to '1') but do not have either a CRC error, an alignment error, nor a receive symbol error.



### 24.9.72 GMAC Jabbers Received Register

**Name:** JR  
**Offset:** 0x18C  
**Reset:** 0x00000000  
**Property:** Read-Only

	31	30	29	28	27	26	25	24
Access								
Reset								
	23	22	21	20	19	18	17	16
Access								
Reset								
	15	14	13	12	11	10	9	8
							JR[X[9:8]	
Access							R	R
Reset							0	0
	7	6	5	4	3	2	1	0
	JR[X[7:0]							
Access	R	R	R	R	R	R	R	R
Reset	0	0	0	0	0	0	0	0

**Bits 9:0 – JR[X[9:0]** Jabbers Received

This bit field counts the number of frames received exceeding 1518 Bytes in length (1536 Bytes if NCFGGR.MAXFS is written to '1') and have either a CRC error, an alignment error or a receive symbol error.

### 24.9.73 GMAC Frame Check Sequence Errors Register

**Name:** FCSE  
**Offset:** 0x190  
**Reset:** 0x00000000  
**Property:** Read-only

Bit	31	30	29	28	27	26	25	24
Access								
Reset								
Bit	23	22	21	20	19	18	17	16
Access								
Reset								
Bit	15	14	13	12	11	10	9	8
							FCKR[9:8]	
Access							R	R
Reset							0	0
Bit	7	6	5	4	3	2	1	0
	FCKR[7:0]							
Access	R	R	R	R	R	R	R	R
Reset	0	0	0	0	0	0	0	0

**Bits 9:0 – FCKR[9:0]** Frame Check Sequence Errors

The register counts frames that are an integral number of bytes, have bad CRC and are between 64 and 1518 bytes in length (1536 Bytes if NCFGR.MAXFS is written to '1'). This register is also incremented if a symbol error is detected and the frame is of valid length and has an integral number of bytes.

This register is incremented for a frame with bad FCS, regardless of whether it is copied to memory due to ignore FCS mode (enabled by writing NCFGR.IRXFCS=1).

### 24.9.74 GMAC Length Field Frame Errors Register

**Name:** LFFE  
**Offset:** 0x194  
**Reset:** 0x00000000  
**Property:** Read-Only

	31	30	29	28	27	26	25	24
Access								
Reset								
	23	22	21	20	19	18	17	16
Access								
Reset								
	15	14	13	12	11	10	9	8
							LFFER[9:8]	
Access							R	R
Reset							0	0
	7	6	5	4	3	2	1	0
	LFFER[7:0]							
Access	R	R	R	R	R	R	R	R
Reset	0	0	0	0	0	0	0	0

**Bits 9:0 – LFFER[9:0] Length Field Frame Errors**

This bit field counts the number of frames received that have a measured length shorter than that extracted from the length field (Bytes 13 and 14). This condition is only counted if the value of the length field is less than 0x0600, the frame is not of excessive length and checking is enabled by writing a '1' to the Length Field Error Frame Discard bit in the Network Configuration Register (GMAC\_NCFGR.LFFERD).

### 24.9.75 GMAC Receive Symbol Errors Register

**Name:** RSE  
**Offset:** 0x198  
**Reset:** 0x00000000  
**Property:** Read-only

	31	30	29	28	27	26	25	24
Access								
Reset								
	23	22	21	20	19	18	17	16
Access								
Reset								
	15	14	13	12	11	10	9	8
							RXSE[9:8]	
Access							R	R
Reset							0	0
	7	6	5	4	3	2	1	0
	RXSE[7:0]							
Access	R	R	R	R	R	R	R	R
Reset	0	0	0	0	0	0	0	0

**Bits 9:0 – RXSE[9:0]** Receive Symbol Errors

This bit field counts the number of frames that had GRXER asserted during reception. For 10/100 mode symbol errors are counted regardless of frame length checks. Receive symbol errors will also be counted as an FCS or alignment error if the frame is between 64 and 1518 Bytes (1536 Bytes if NCFGR.MAXFS=1). If the frame is larger it will be recorded as a jabber error.

### 24.9.76 GMAC Alignment Errors Register

**Name:** AE  
**Offset:** 0x19C  
**Reset:** 0x00000000  
**Property:** Read-only

	Bit	31	30	29	28	27	26	25	24
Access									
Reset									
	Bit	23	22	21	20	19	18	17	16
Access									
Reset									
	Bit	15	14	13	12	11	10	9	8
								AER[9:8]	
Access								R	R
Reset								0	0
	Bit	7	6	5	4	3	2	1	0
		AER[7:0]							
Access		R	R	R	R	R	R	R	R
Reset		0	0	0	0	0	0	0	0

**Bits 9:0 – AER[9:0] Alignment Errors**

This bit field counts the frames that are not an integral number of bytes long and have bad CRC when their length is truncated to an integral number of Bytes and are between 64 and 1518 Bytes in length (1536 if NCFGR.MAXFS=1). This register is also incremented if a symbol error is detected and the frame is of valid length and does not have an integral number of bytes.

# SAM D5x/E5x Family Data Sheet

## GMAC - Ethernet MAC

### 24.9.77 GMAC Receive Resource Errors Register

**Name:** RRE  
**Offset:** 0x1A0  
**Reset:** 0x00000000  
**Property:** Read-Only

	31	30	29	28	27	26	25	24
	[Greyed out bits 31:24]							
Access								
Reset								
	23	22	21	20	19	18	17	16
	[Greyed out bits 23:18]						RXRER[17:16]	
Access							R	R
Reset							0	0
	15	14	13	12	11	10	9	8
	RXRER[15:8]							
Access	R	R	R	R	R	R	R	R
Reset	0	0	0	0	0	0	0	0
	7	6	5	4	3	2	1	0
	RXRER[7:0]							
Access	R	R	R	R	R	R	R	R
Reset	0	0	0	0	0	0	0	0

**Bits 17:0 – RXRER[17:0] Receive Resource Errors**

This bit field counts frames that are not an integral number of bytes long and have bad CRC when their length is truncated to an integral number of Bytes and are between 64 and 1518 Bytes in length (1536 if NCFGR.MAXFS=1). This bit field is also incremented if a symbol error is detected and the frame is of valid length and does not have an integral number of Bytes.

# SAM D5x/E5x Family Data Sheet

## GMAC - Ethernet MAC

### 24.9.78 GMAC Receive Overruns Register

**Name:** ROE  
**Offset:** 0x1A4  
**Reset:** 0x00000000  
**Property:** Read-Only

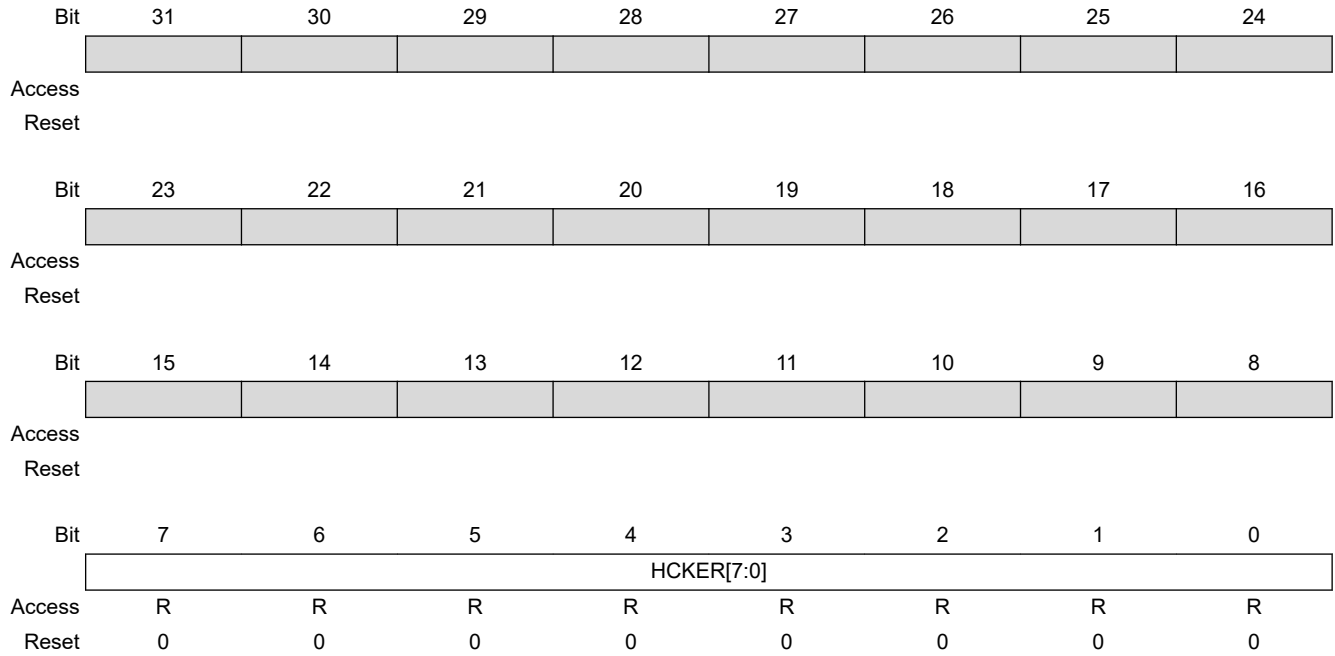
	Bit	31	30	29	28	27	26	25	24
Access									
Reset									
	Bit	23	22	21	20	19	18	17	16
Access									
Reset									
	Bit	15	14	13	12	11	10	9	8
								RXOVR[9:8]	
Access								R	R
Reset								0	0
	Bit	7	6	5	4	3	2	1	0
		RXOVR[7:0]							
Access		R	R	R	R	R	R	R	R
Reset		0	0	0	0	0	0	0	0

**Bits 9:0 – RXOVR[9:0] Receive Overruns**

This bit field counts the number of frames that are address recognized but were not copied to memory due to a receive overrun.

### 24.9.79 GMAC IP Header Checksum Errors Register

**Name:** IHCE  
**Offset:** 0x1A8  
**Reset:** 0x00000000  
**Property:** Read-only



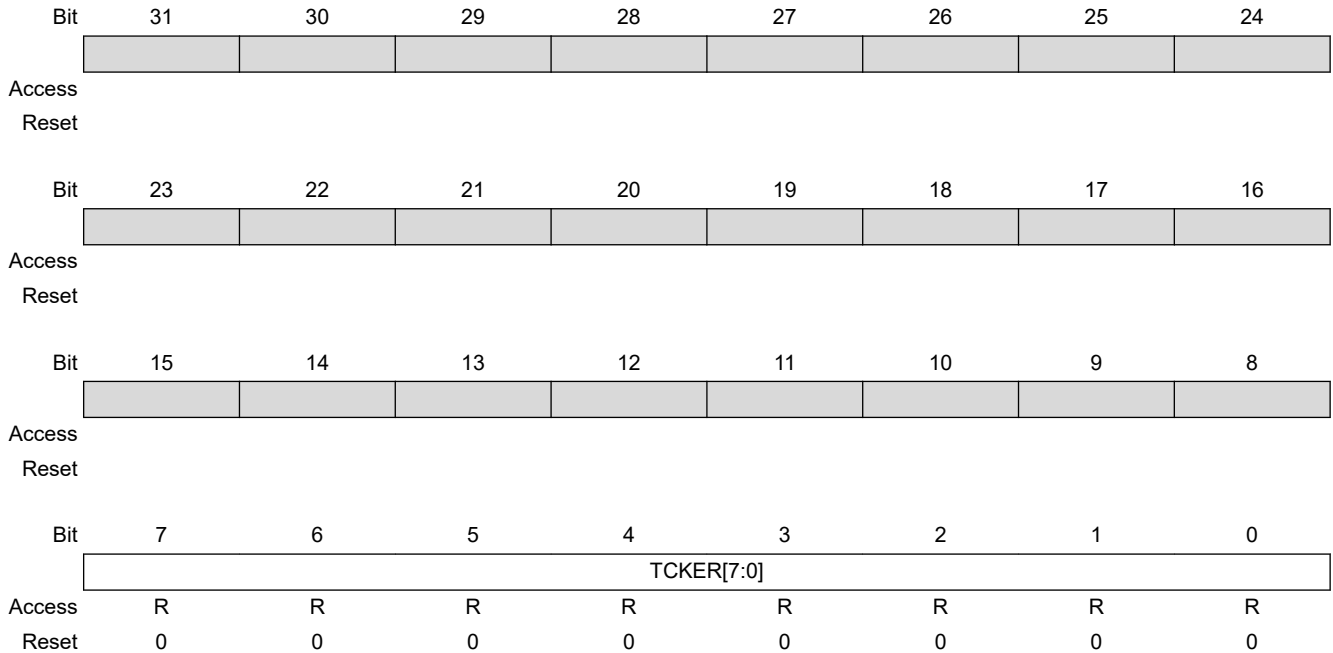
**Bits 7:0 – HCKER[7:0] IP Header Checksum Errors**

This register counts the number of frames discarded due to an incorrect IP header checksum, but are between 64 and 1518 Bytes (1536 Bytes if GMAC\_NCFGR.MAXFS=1) and do not have a CRC error, an alignment error, nor a symbol error.



### 24.9.80 GMAC TCP Checksum Errors Register

**Name:** TCE  
**Offset:** 0x1AC  
**Reset:** 0x00000000  
**Property:** Read-Only

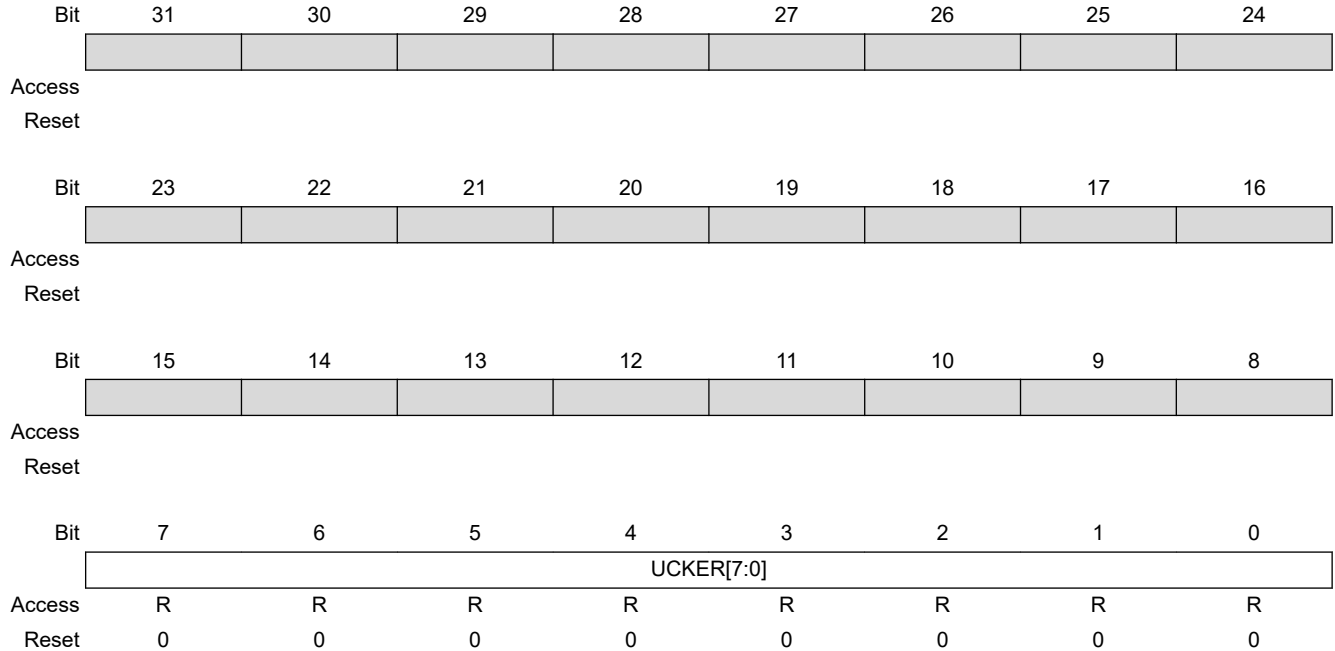


**Bits 7:0 – TCKER[7:0]** TCP Checksum Errors

This register counts the number of frames discarded due to an incorrect TCP checksum, but are between 64 and 1518 Bytes (1536 Bytes if NCFGR.MAXFS=1) and do not have a CRC error, an alignment error, nor a symbol error.

### 24.9.81 GMAC UDP Checksum Errors Register

**Name:** UCE  
**Offset:** 0x1B0  
**Reset:** 0x00000000  
**Property:** Read-Only



**Bits 7:0 – UCKER[7:0]** UDP Checksum Errors

This register counts the number of frames discarded due to an incorrect UDP checksum, but are between 64 and 1518 Bytes (1536 Bytes if NCFGR.MAXFS=1) and do not have a CRC error, an alignment error, nor a symbol error.

# SAM D5x/E5x Family Data Sheet

## GMAC - Ethernet MAC

### 24.9.82 GMAC 1588 Timer Increment Sub-nanoseconds Register

**Name:** TISUBN  
**Offset:** 0x1BC  
**Reset:** 0x00000000  
**Property:** Read/Write

	31	30	29	28	27	26	25	24
Access								
Reset								
	23	22	21	20	19	18	17	16
Access								
Reset								
	15	14	13	12	11	10	9	8
	LSBTIR[15:8]							
Access	R/W	R/W	R/W	R/W	R/W	R/W	R/W	R/W
Reset	0	0	0	0	0	0	0	0
	7	6	5	4	3	2	1	0
	LSBTIR[7:0]							
Access	R/W	R/W	R/W	R/W	R/W	R/W	R/W	R/W
Reset	0	0	0	0	0	0	0	0

**Bits 15:0 – LSBTIR[15:0]** Lower Significant Bits of Timer Increment Register

Lower significant bits of Timer Increment Register [15:0], giving a 24-bit timer\_increment counter. These bits are the sub-ns value which the 1588 timer will be incremented each clock cycle. Bit n = 2<sup>(n-16)</sup> ns giving a resolution of approximately 15.2E<sup>-15</sup> sec.

# SAM D5x/E5x Family Data Sheet

## GMAC - Ethernet MAC

### 24.9.83 GMAC 1588 Timer Seconds High Register

**Name:** TSH  
**Offset:** 0x1C0  
**Reset:** 0x00000000  
**Property:** Read/Write

	Bit	31	30	29	28	27	26	25	24
		[Register Bits 24-31]							
Access									
Reset									
	Bit	23	22	21	20	19	18	17	16
		[Register Bits 16-23]							
Access									
Reset									
	Bit	15	14	13	12	11	10	9	8
		TCS[15:8]							
Access		R/W	R/W	R/W	R/W	R/W	R/W	R/W	R/W
Reset		0	0	0	0	0	0	0	0
	Bit	7	6	5	4	3	2	1	0
		TCS[7:0]							
Access		R/W	R/W	R/W	R/W	R/W	R/W	R/W	R/W
Reset		0	0	0	0	0	0	0	0

**Bits 15:0 – TCS[15:0]** Timer Count in Seconds

This register is writable. It increments by 1 when the IEEE 1588 nanoseconds counter counts to one second. It may also be incremented when the Timer Adjust Register is written.

# SAM D5x/E5x Family Data Sheet

## GMAC - Ethernet MAC

### 24.9.84 GMAC 1588 Timer Seconds Low Register

**Name:** TSL  
**Offset:** 0x1D0  
**Reset:** 0x00000000  
**Property:** Read/Write

	Bit	31	30	29	28	27	26	25	24
		TCS[31:24]							
Access		R/W	R/W	R/W	R/W	R/W	R/W	R/W	R/W
Reset		0	0	0	0	0	0	0	0
	Bit	23	22	21	20	19	18	17	16
		TCS[23:16]							
Access		R/W	R/W	R/W	R/W	R/W	R/W	R/W	R/W
Reset		0	0	0	0	0	0	0	0
	Bit	15	14	13	12	11	10	9	8
		TCS[15:8]							
Access		R/W	R/W	R/W	R/W	R/W	R/W	R/W	R/W
Reset		0	0	0	0	0	0	0	0
	Bit	7	6	5	4	3	2	1	0
		TCS[7:0]							
Access		R/W	R/W	R/W	R/W	R/W	R/W	R/W	R/W
Reset		0	0	0	0	0	0	0	0

**Bits 31:0 – TCS[31:0]** Timer Count in Seconds

This register is writable. It increments by 1 when the IEEE 1588 nanoseconds counter counts to one second. It may also be incremented when the Timer Adjust Register is written.

# SAM D5x/E5x Family Data Sheet

## GMAC - Ethernet MAC

### 24.9.85 1588 Timer Sync Strobe Seconds [31:0] Register

**Name:** TSSSL  
**Offset:** 0x1C8  
**Reset:** 0x00000000  
**Property:** Read/Write

	Bit	31	30	29	28	27	26	25	24
		VTS[31:24]							
Access		R/W	R/W	R/W	R/W	R/W	R/W	R/W	R/W
Reset		0	0	0	0	0	0	0	0
	Bit	23	22	21	20	19	18	17	16
		VTS[23:16]							
Access		R/W	R/W	R/W	R/W	R/W	R/W	R/W	R/W
Reset		0	0	0	0	0	0	0	0
	Bit	15	14	13	12	11	10	9	8
		VTS[15:8]							
Access		R/W	R/W	R/W	R/W	R/W	R/W	R/W	R/W
Reset		0	0	0	0	0	0	0	0
	Bit	7	6	5	4	3	2	1	0
		VTS[7:0]							
Access		R/W	R/W	R/W	R/W	R/W	R/W	R/W	R/W
Reset		0	0	0	0	0	0	0	0

**Bits 31:0 – VTS[31:0]** Value of Timer Seconds Register Capture

This register is writable. It increments by 1 when the IEEE 1588 nanoseconds counter counts to one second. It may also be incremented when the Timer Adjust Register is written.

# SAM D5x/E5x Family Data Sheet

## GMAC - Ethernet MAC

### 24.9.86 GMAC 1588 Timer Sync Strobe Nanoseconds Register

**Name:** TSSN  
**Offset:** 0x1CC  
**Reset:** 0x00000000  
**Property:** Read/Write

	Bit	31	30	29	28	27	26	25	24
		VTN[29:24]							
Access				R/W	R/W	R/W	R/W	R/W	R/W
Reset				0	0	0	0	0	0
	Bit	23	22	21	20	19	18	17	16
		VTN[23:16]							
Access		R/W	R/W	R/W	R/W	R/W	R/W	R/W	R/W
Reset		0	0	0	0	0	0	0	0
	Bit	15	14	13	12	11	10	9	8
		VTN[15:8]							
Access		R/W	R/W	R/W	R/W	R/W	R/W	R/W	R/W
Reset		0	0	0	0	0	0	0	0
	Bit	7	6	5	4	3	2	1	0
		VTN[7:0]							
Access		R/W	R/W	R/W	R/W	R/W	R/W	R/W	R/W
Reset		0	0	0	0	0	0	0	0

**Bits 29:0 – VTN[29:0]** Value Timer Nanoseconds Register Capture

This register is writable. It increments by 1 when the IEEE 1588 nanoseconds counter counts to one second. It may also be incremented when the Timer Adjust Register is written.

# SAM D5x/E5x Family Data Sheet

## GMAC - Ethernet MAC

### 24.9.87 GMAC 1588 Timer Nanoseconds Register

**Name:** TN  
**Offset:** 0x1D4  
**Reset:** 0x00000000  
**Property:** Read/Write

	Bit	31	30	29	28	27	26	25	24
				TNS[29:24]					
Access				R/W	R/W	R/W	R/W	R/W	R/W
Reset				0	0	0	0	0	0
	Bit	23	22	21	20	19	18	17	16
		TNS[23:16]							
Access		R/W	R/W	R/W	R/W	R/W	R/W	R/W	R/W
Reset		0	0	0	0	0	0	0	0
	Bit	15	14	13	12	11	10	9	8
		TNS[15:8]							
Access		R/W	R/W	R/W	R/W	R/W	R/W	R/W	R/W
Reset		0	0	0	0	0	0	0	0
	Bit	7	6	5	4	3	2	1	0
		TNS[7:0]							
Access		R/W	R/W	R/W	R/W	R/W	R/W	R/W	R/W
Reset		0	0	0	0	0	0	0	0

**Bits 29:0 – TNS[29:0]** Timer Count in Nanoseconds

This register is writable. It can also be adjusted by writes to the IEEE 1588 Timer Adjust Register. It increments by the value of the IEEE 1588 Timer Increment Register each clock cycle.



# SAM D5x/E5x Family Data Sheet

## GMAC - Ethernet MAC

### 24.9.88 GMAC 1588 Timer Adjust Register

**Name:** TA  
**Offset:** 0x1D8  
**Reset:** 0x00000000  
**Property:** Write-Only

	Bit	31	30	29	28	27	26	25	24
		ADJ		ITDT[29:24]					
Access		W		W	W	W	W	W	W
Reset		0		0	0	0	0	0	0
	Bit	23	22	21	20	19	18	17	16
		ITDT[23:16]							
Access		W	W	W	W	W	W	W	W
Reset		0	0	0	0	0	0	0	0
	Bit	15	14	13	12	11	10	9	8
		ITDT[15:8]							
Access		W	W	W	W	W	W	W	W
Reset		0	0	0	0	0	0	0	0
	Bit	7	6	5	4	3	2	1	0
		ITDT[7:0]							
Access		W	W	W	W	W	W	W	W
Reset		0	0	0	0	0	0	0	0

**Bit 31 – ADJ** Adjust 1588 Timer

Write as '1' to subtract from the 1588 timer. Write as '0' to add to it.

**Bits 29:0 – ITDT[29:0]** Increment/Decrement

The number of nanoseconds to increment or decrement the IEEE 1588 Timer Nanoseconds Register. If necessary, the IEEE 1588 Seconds Register will be incremented or decremented.

# SAM D5x/E5x Family Data Sheet

## GMAC - Ethernet MAC

### 24.9.89 GMAC IEEE 1588 Timer Increment Register

**Name:** TI  
**Offset:** 0x1DC  
**Reset:** 0x00000000  
**Property:** Read/Write

	31	30	29	28	27	26	25	24
	[Greyed out register bits 31:24]							
Access								
Reset								
	23	22	21	20	19	18	17	16
	NIT[7:0]							
Access	R/W	R/W	R/W	R/W	R/W	R/W	R/W	R/W
Reset	0	0	0	0	0	0	0	0
	15	14	13	12	11	10	9	8
	ACNS[7:0]							
Access	R/W	R/W	R/W	R/W	R/W	R/W	R/W	R/W
Reset	0	0	0	0	0	0	0	0
	7	6	5	4	3	2	1	0
	CNS[7:0]							
Access	R/W	R/W	R/W	R/W	R/W	R/W	R/W	R/W
Reset	0	0	0	0	0	0	0	0

**Bits 23:16 – NIT[7:0]** Number of Increments  
 The number of increments after which the alternative increment is used.

**Bits 15:8 – ACNS[7:0]** Alternative Count Nanoseconds  
 Alternative count of nanoseconds by which the 1588 Timer Nanoseconds Register will be incremented each clock cycle.

**Bits 7:0 – CNS[7:0]** Count Nanoseconds  
 A count of nanoseconds by which the IEEE 1588 Timer Nanoseconds Register will be incremented each clock cycle.

# SAM D5x/E5x Family Data Sheet

## GMAC - Ethernet MAC

### 24.9.90 GMAC PTP Event Frame Transmitted Seconds Low Register

**Name:** EFTSL  
**Offset:** 0x1E0  
**Reset:** 0x00000000  
**Property:** Read-only

	Bit	31	30	29	28	27	26	25	24
		RUD[31:24]							
Access		R	R	R	R	R	R	R	R
Reset		0	0	0	0	0	0	0	0
	Bit	23	22	21	20	19	18	17	16
		RUD[23:16]							
Access		R	R	R	R	R	R	R	R
Reset		0	0	0	0	0	0	0	0
	Bit	15	14	13	12	11	10	9	8
		RUD[15:8]							
Access		R	R	R	R	R	R	R	R
Reset		0	0	0	0	0	0	0	0
	Bit	7	6	5	4	3	2	1	0
		RUD[7:0]							
Access		R	R	R	R	R	R	R	R
Reset		0	0	0	0	0	0	0	0

**Bits 31:0 – RUD[31:0] Register Update**

The register is updated with the value that the IEEE 1588 Timer Seconds Register holds when the SFD of a PTP transmit primary event crosses the MII interface. An interrupt is issued when the register is updated.

# SAM D5x/E5x Family Data Sheet

## GMAC - Ethernet MAC

### 24.9.91 GMAC PTP Event Frame Transmitted Nanoseconds Register

**Name:** EFTN  
**Offset:** 0x1E4  
**Reset:** 0x00000000  
**Property:** Read-only

	Bit	31	30	29	28	27	26	25	24
				RUD[29:24]					
Access				R	R	R	R	R	R
Reset				0	0	0	0	0	0
	Bit	23	22	21	20	19	18	17	16
		RUD[23:16]							
Access		R	R	R	R	R	R	R	R
Reset		0	0	0	0	0	0	0	0
	Bit	15	14	13	12	11	10	9	8
		RUD[15:8]							
Access		R	R	R	R	R	R	R	R
Reset		0	0	0	0	0	0	0	0
	Bit	7	6	5	4	3	2	1	0
		RUD[7:0]							
Access		R	R	R	R	R	R	R	R
Reset		0	0	0	0	0	0	0	0

**Bits 29:0 – RUD[29:0] Register Update**

The register is updated with the value that the IEEE 1588 Timer Nanoseconds Register holds when the SFD of a PTP transmit primary event crosses the MII interface. An interrupt is issued when the bit field is updated.

# SAM D5x/E5x Family Data Sheet

## GMAC - Ethernet MAC

### 24.9.92 GMAC PTP Event Frame Received Seconds Low Register

**Name:** EFRSL  
**Offset:** 0x1E8  
**Reset:** 0x00000000  
**Property:** Read-only

	Bit	31	30	29	28	27	26	25	24
		RUD[31:24]							
Access		R	R	R	R	R	R	R	R
Reset		0	0	0	0	0	0	0	0
	Bit	23	22	21	20	19	18	17	16
		RUD[23:16]							
Access		R	R	R	R	R	R	R	R
Reset		0	0	0	0	0	0	0	0
	Bit	15	14	13	12	11	10	9	8
		RUD[15:8]							
Access		R	R	R	R	R	R	R	R
Reset		0	0	0	0	0	0	0	0
	Bit	7	6	5	4	3	2	1	0
		RUD[7:0]							
Access		R	R	R	R	R	R	R	R
Reset		0	0	0	0	0	0	0	0

#### Bits 31:0 – RUD[31:0] Register Update

The register is updated with the value that the IEEE 1588 Timer Seconds Register holds when the SFD of a PTP receive primary event crosses the MII interface. An interrupt is issued when the register is updated.

# SAM D5x/E5x Family Data Sheet

## GMAC - Ethernet MAC

### 24.9.93 GMAC PTP Event Frame Received Nanoseconds Register

**Name:** EFRN  
**Offset:** 0x1EC  
**Reset:** 0x00000000  
**Property:** Read-only

	31	30	29	28	27	26	25	24
			RUD[29:24]					
Access			R	R	R	R	R	R
Reset			0	0	0	0	0	0
	23	22	21	20	19	18	17	16
	RUD[23:16]							
Access	R	R	R	R	R	R	R	R
Reset	0	0	0	0	0	0	0	0
	15	14	13	12	11	10	9	8
	RUD[15:8]							
Access	R	R	R	R	R	R	R	R
Reset	0	0	0	0	0	0	0	0
	7	6	5	4	3	2	1	0
	RUD[7:0]							
Access	R	R	R	R	R	R	R	R
Reset	0	0	0	0	0	0	0	0

**Bits 29:0 – RUD[29:0] Register Update**

The register is updated with the value that the IEEE 1588 Timer Nanoseconds Register holds when the SFD of a PTP receive primary event crosses the MII interface. An interrupt is issued when the register is updated.

# SAM D5x/E5x Family Data Sheet

## GMAC - Ethernet MAC

### 24.9.94 GMAC PTP Peer Event Frame Transmitted Seconds Low Register

**Name:** PEFTSL  
**Offset:** 0x1F0  
**Reset:** 0x00000000  
**Property:** Read-Only

	Bit	31	30	29	28	27	26	25	24
		RUD[31:24]							
Access		R	R	R	R	R	R	R	R
Reset		0	0	0	0	0	0	0	0
	Bit	23	22	21	20	19	18	17	16
		RUD[23:16]							
Access		R	R	R	R	R	R	R	R
Reset		0	0	0	0	0	0	0	0
	Bit	15	14	13	12	11	10	9	8
		RUD[15:8]							
Access		R	R	R	R	R	R	R	R
Reset		0	0	0	0	0	0	0	0
	Bit	7	6	5	4	3	2	1	0
		RUD[7:0]							
Access		R	R	R	R	R	R	R	R
Reset		0	0	0	0	0	0	0	0

#### Bits 31:0 – RUD[31:0] Register Update

The register is updated with the value that the IEEE 1588 Timer Seconds Register holds when the SFD of a PTP transmit peer event crosses the MII interface. An interrupt is issued when the register is updated.

# SAM D5x/E5x Family Data Sheet

## GMAC - Ethernet MAC

### 24.9.95 GMAC PTP Peer Event Frame Transmitted Nanoseconds Register

**Name:** PEFTN  
**Offset:** 0x1F4  
**Reset:** 0x00000000  
**Property:** Read-Only

	31	30	29	28	27	26	25	24
			RUD[29:24]					
Access			R	R	R	R	R	R
Reset			0	0	0	0	0	0
	23	22	21	20	19	18	17	16
	RUD[23:16]							
Access	R	R	R	R	R	R	R	R
Reset	0	0	0	0	0	0	0	0
	15	14	13	12	11	10	9	8
	RUD[15:8]							
Access	R	R	R	R	R	R	R	R
Reset	0	0	0	0	0	0	0	0
	7	6	5	4	3	2	1	0
	RUD[7:0]							
Access	R	R	R	R	R	R	R	R
Reset	0	0	0	0	0	0	0	0

**Bits 29:0 – RUD[29:0] Register Update**

The register is updated with the value that the 1588 Timer Nanoseconds Register holds when the SFD of a PTP transmit peer event crosses the MII interface. An interrupt is issued when the register is updated.



# SAM D5x/E5x Family Data Sheet

## GMAC - Ethernet MAC

### 24.9.96 GMAC PTP Peer Event Frame Received Seconds Low Register

**Name:** PEFRSL  
**Offset:** 0x1F8  
**Reset:** 0x00000000  
**Property:** Read-Only

	Bit	31	30	29	28	27	26	25	24
		RUD[31:24]							
Access		R	R	R	R	R	R	R	R
Reset		0	0	0	0	0	0	0	0
	Bit	23	22	21	20	19	18	17	16
		RUD[23:16]							
Access		R	R	R	R	R	R	R	R
Reset		0	0	0	0	0	0	0	0
	Bit	15	14	13	12	11	10	9	8
		RUD[15:8]							
Access		R	R	R	R	R	R	R	R
Reset		0	0	0	0	0	0	0	0
	Bit	7	6	5	4	3	2	1	0
		RUD[7:0]							
Access		R	R	R	R	R	R	R	R
Reset		0	0	0	0	0	0	0	0

#### Bits 31:0 – RUD[31:0] Register Update

The register is updated with the value that the IEEE 1588 Timer Seconds Register holds when the SFD of a PTP receive primary event crosses the MII interface. An interrupt is issued when the register is updated.

# SAM D5x/E5x Family Data Sheet

## GMAC - Ethernet MAC

### 24.9.97 GMAC PTP Peer Event Frame Received Nanoseconds Register

**Name:** PEFRN  
**Offset:** 0x1FC  
**Reset:** 0x00000000  
**Property:** Read-Only

	31	30	29	28	27	26	25	24
			RUD[29:24]					
Access			R	R	R	R	R	R
Reset			0	0	0	0	0	0
	23	22	21	20	19	18	17	16
	RUD[23:16]							
Access	R	R	R	R	R	R	R	R
Reset	0	0	0	0	0	0	0	0
	15	14	13	12	11	10	9	8
	RUD[15:8]							
Access	R	R	R	R	R	R	R	R
Reset	0	0	0	0	0	0	0	0
	7	6	5	4	3	2	1	0
	RUD[7:0]							
Access	R	R	R	R	R	R	R	R
Reset	0	0	0	0	0	0	0	0

**Bits 29:0 – RUD[29:0] Register Update**

The register is updated with the value that the IEEE 1588 Timer Nanoseconds Register holds when the SFD of a PTP receive primary event crosses the MII interface. An interrupt is issued when the register is updated.

# SAM D5x/E5x Family Data Sheet

## GMAC - Ethernet MAC

### 24.9.98 Received LPI Transitions

**Name:** RLPITR  
**Offset:** 0x270  
**Reset:** 0x00000000  
**Property:** Read-Only

	Bit	31	30	29	28	27	26	25	24
		[Bit Field Diagram: 8 boxes from bit 31 to 24]							
Access									
Reset									
	Bit	23	22	21	20	19	18	17	16
		[Bit Field Diagram: 8 boxes from bit 23 to 16]							
Access									
Reset									
	Bit	15	14	13	12	11	10	9	8
		RLPITR[15:8]							
Access		R	R	R	R	R	R	R	R
Reset		0	0	0	0	0	0	0	0
	Bit	7	6	5	4	3	2	1	0
		RLPITR[7:0]							
Access		R	R	R	R	R	R	R	R
Reset		0	0	0	0	0	0	0	0

**Bits 15:0 – RLPITR[15:0]** Received LPI Transitions

The value of this bit field is a counter of transitions from receiving normal idle to receiving low power idle. Cleared on read.

# SAM D5x/E5x Family Data Sheet

## GMAC - Ethernet MAC

### 24.9.99 Received LPI Time

**Name:** RLPITI  
**Offset:** 0x274  
**Reset:** 0x00000000  
**Property:** Read-Only

	Bit	31	30	29	28	27	26	25	24
Access									
Reset									
	Bit	23	22	21	20	19	18	17	16
		RLPITI[23:16]							
Access		R	R	R	R	R	R	R	R
Reset		0	0	0	0	0	0	0	0
	Bit	15	14	13	12	11	10	9	8
		RLPITI[15:8]							
Access		R	R	R	R	R	R	R	R
Reset		0	0	0	0	0	0	0	0
	Bit	7	6	5	4	3	2	1	0
		RLPITI[7:0]							
Access		R	R	R	R	R	R	R	R
Reset		0	0	0	0	0	0	0	0

**Bits 23:0 – RLPITI[23:0] Received LPI Time**

The value of this bit field increments once every 16 AHB clock cycles when the Low Power Idle Enable bit in the Network Configuration Register (NCR.LPI) is written to '1'. Cleared on read.

### 24.9.100 Transmit LPI Transitions

**Name:** TLPITR  
**Offset:** 0x278  
**Reset:** 0x00000000  
**Property:** Read-Only

	Bit	31	30	29	28	27	26	25	24
		[Bit Fields 24-31]							
Access									
Reset									
	Bit	23	22	21	20	19	18	17	16
		[Bit Fields 16-23]							
Access									
Reset									
	Bit	15	14	13	12	11	10	9	8
		TLPITR[15:8]							
Access		R	R	R	R	R	R	R	R
Reset		0	0	0	0	0	0	0	0
	Bit	7	6	5	4	3	2	1	0
		TLPITR[7:0]							
Access		R	R	R	R	R	R	R	R
Reset		0	0	0	0	0	0	0	0

**Bits 15:0 – TLPITR[15:0]** Transmit LPI Transitions

A count of the number of times the Low Power Idle Enable bit in the Network Configuration Register (NCR.LPI) goes from '0' to '1'.

# SAM D5x/E5x Family Data Sheet

## GMAC - Ethernet MAC

### 24.9.101 Transmit LPI Time

**Name:** TLPITI  
**Offset:** 0x27C  
**Reset:** 0x00000000  
**Property:** Read-Only

	Bit	31	30	29	28	27	26	25	24
Access									
Reset									
	Bit	23	22	21	20	19	18	17	16
		RLPITI[23:16]							
Access		R	R	R	R	R	R	R	R
Reset		0	0	0	0	0	0	0	0
	Bit	15	14	13	12	11	10	9	8
		RLPITI[15:8]							
Access		R	R	R	R	R	R	R	R
Reset		0	0	0	0	0	0	0	0
	Bit	7	6	5	4	3	2	1	0
		RLPITI[7:0]							
Access		R	R	R	R	R	R	R	R
Reset		0	0	0	0	0	0	0	0

**Bits 23:0 – RLPITI[23:0] Transmit LPI Time**

The value of this bit field increments once every 16 AHB clock cycles when the Low Power Idle Enable bit in the Network Configuration Register (NCR.LPI) is written to '1'. Cleared on read.

## 25. NVMCTRL – Nonvolatile Memory Controller

### 25.1 Overview

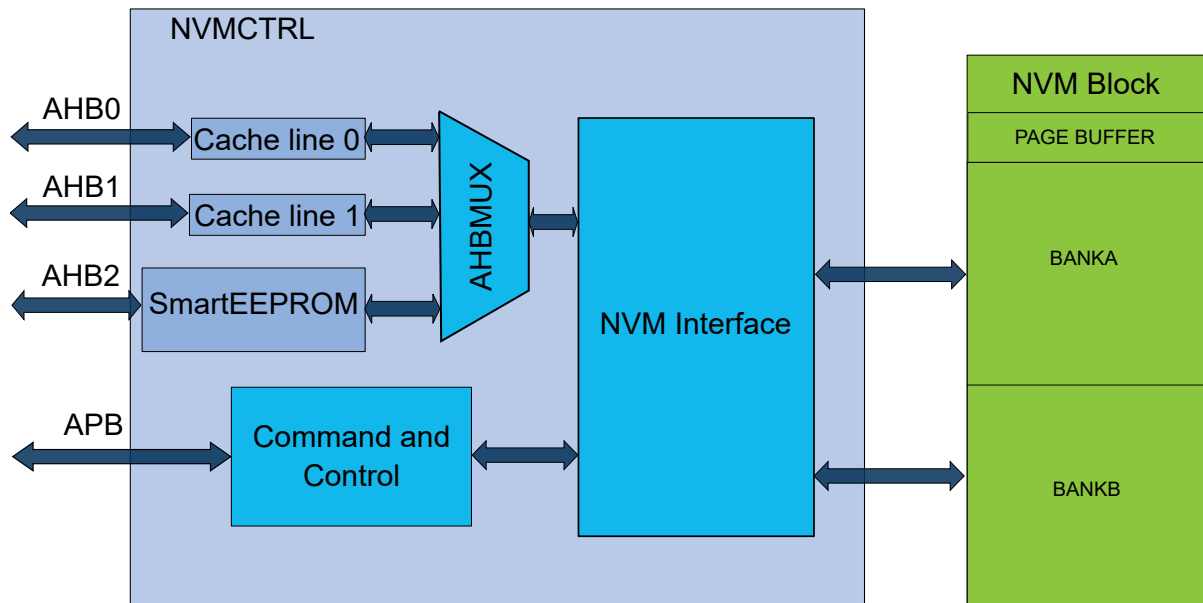
Non-volatile memory (NVM) is a reprogrammable flash memory that retains program and data storage, even when powered off. The NVM Controller (NVMCTRL) embeds two banks; one bank can be read while the other is programmed (RWW). It is connected to the AHB and APB bus interfaces for system access to the NVM block. The AHB interfaces are used for reads and writes to the NVM block, while the APB interface is used for commands and configuration.

### 25.2 Features

- Two 32-bit AHB interfaces for reads and writes in the NVM main address space
- SmartEEPROM (integrated EEPROM emulation algorithm)
- Read while write (Any bank can be read while programming the other one)
- All NVM sections are memory mapped to the AHB, including calibration and system configuration
- 32-bit APB interface for commands and control
- Programmable wait states for read optimization
- 32 regions can be individually protected or unprotected
- Additional protection for boot loader
- Supports device protection through a security bit
- Interface to Power Manager to power-down flash blocks while in sleep modes
- Can optionally wake up on exit from sleep or on first access
- Single line cache per AHB interface
- Dual bank for safer application upgrade
- Error Correction Code (ECC)

### 25.3 Block Diagram

Figure 25-1. Block Diagram



### 25.4 Signal Description

Not applicable.

### 25.5 Product Dependencies

In order to use this peripheral, other parts of the system must be configured correctly, as described in the following sections.

#### 25.5.1 Power Management

The NVMCTRL will continue to operate in any sleep mode where the selected source clock is running. The NVMCTRL interrupts can be used to wake up the device from sleep modes.

The NVM block can be put into a low-power mode either automatically when the Power Manager enters standby mode, or when the SPRM command is issued. The NVMCTRL can wake-up when the Power Manager leaves sleep mode or on AHB access or when a command requires the NVM to be active. This is based on the Control A register (CTRLA) PRM bit setting. Read the CTRLA register description for more details.

NVM wake-up time can be traded with static power consumption depending on the PM STDBYCFG.FASTWKUP setting.

#### Related Links

[18. PM – Power Manager](#)

#### 25.5.2 Clocks

Two synchronous clocks are used by the NVMCTRL. One is provided by the AHB bus (CLK\_NVMCTRL\_AHB) and the other is provided by the APB bus (CLK\_NVMCTRL\_APB). When changing the AHB bus frequency, the user must ensure that the NVM Controller is configured with the



# SAM D5x/E5x Family Data Sheet

## NVMCTRL – Nonvolatile Memory Controller

proper number of wait states. Refer to the Electrical Characteristics for the exact number of wait states to be used for a particular frequency range. Automatic wait state generation can be used by setting the Auto Wait State bit in the Control A register (NVMCTRL.CTRLA.AUTOWS). Alternatively a custom programmable number of wait states can be set by writing the NVM Read Wait State bits (NVMCTRL.CTRLA.RWS) to optimize performance.

### Related Links

[25.8.1 CTRLA](#)

### 25.5.3 DMA

The NVMCTRL supports AHB burst transfers. It is possible to write the page buffer in sequence without AHB re arbitration in case of concurrent AHB writes to the page buffer to guarantee data integrity.

### 25.5.4 Interrupts

The NVM Controller interrupt request line is connected to the interrupt controller. Using the NVMCTRL interrupt requires the interrupt controller to be programmed first.

### 25.5.5 Debug Operation

When the CPU is halted in debug mode, the ECC feature of the NVMCTRL will correct and log ECC errors based on the table below.

**Table 25-1. ECC Debug Operation**

DBGCTRL.ECCELOG	DBGCTRL.ECCDIS	DBGCTRL.ECCDIS
0	0	ECC errors from debugger reads are corrected, but not logged in INTFLAG.
1	0	ECC errors from debugger reads are corrected and logged in INTFLAG.
X	1	ECC errors from debugger reads are neither corrected nor logged in INTFLAG.

Reading the SmartEEPROM configured in buffered mode with a debugger is intrusive, since the pagebuffer must be flushed when the read is performed in a page under modification.

Access to the NVM block can be protected by the security bit. In this case, the NVM block will not be accessible. See the section on the NVMCTRL [25.6.10 Security Bit](#) for details.

### 25.5.6 Register Access Protection

All registers with write-access are optionally write-protected by the Peripheral Access Controller (PAC), except the Interrupt Flag Status and Clear register (INTFLAG).

Optional write protection by the Peripheral Access Controller (PAC) is denoted by the "PAC Write Protection" property in each individual register description.

### Related Links

[27. PAC - Peripheral Access Controller](#)

### 25.5.7 Analog Connections

Not applicable.

## 25.6 Functional Description

### 25.6.1 Principle of Operation

The NVM Controller is a slave on the AHB (AHB0, AHB1 and AHB2) and APB buses. It responds to commands, read requests and write requests, based on user configuration. AHB0 and AHB1 allow access to the NVM main address space, the auxiliary space and the page buffer. AHB2 provides access to the SmartEEPROM interface that indirectly accesses the reserved area in the NVM for EEPROM emulation.

#### 25.6.1.1 Initialization

After power-up, the NVM Controller goes through a power-up sequence. During this time, access to the NVM Controller from the AHB bus is halted. Upon power-up completion, the NVM Controller is operational without any need for user configuration.

#### 25.6.1.2 Software Reset

Software reset is triggered by the SWRST command, and does the following:

- NVM (physical memory) reset
- Device power-up sequence (redo the device calibration)
- Reset all APB configuration registers (and status)

**Note:**

STATUS.READY goes low when the SWRST command starts to execute.

STATUS.READY goes high when the SWRST command has completed.

Any AHB0/1/2 access is stalled until the command has completed.

### 25.6.2 Memory Organization

Memory space is divided in two:

- The main address space where 2 physical NVM banks (BANKA and BANKB) are mapped.
- The auxiliary space which contains:
  - The User page (USER)
  - The calibration page (CB)
  - Factory and signature pages (FS)

BANKA and BANKB can be swapped in the address space. For more information, see Memory Bank Swapping.

Refer to the Physical Memory Map for memory sizes and addresses for each device.

BANKA, BANKB and AUX pages have different erase and write granularities, see the table below.

**Table 25-2. Erase and Write granularity**

	Erase Granularity	Write Granularity
<b>BANKA</b>	Block	Quad-Word or Page
<b>BANKB</b>	Block	Quad-Word or Page
<b>AUX</b>	Page	Quad-Word

The NVM is organized into two banks, each bank is organized into blocks, where each block contains sixteen pages.

# SAM D5x/E5x Family Data Sheet

## NVMCTRL – Nonvolatile Memory Controller

---

The lower blocks in the NVM main address space can be allocated as a boot loader section by using the BOOTPROT fuses, and the upper rows can be allocated to EEPROM.

The NVM memory is separated into six parts:

1. CB space  
Contains factory calibration and system configuration information.
  - Address; 0x00800000
  - Size: 1 page
  - Property: Read-Only
2. FS space  
Contains the factory signature information.
  - Address; 0x00806000
  - Size: 4 pages
  - Property: Read-Only.
3. USER space  
Contains user defined startup configuration. The first word is reserved, and used during the NVMCTRL start-up to automatically configure the device.
  - Address: 0x00804000
  - Size: 1 page
  - Property: Read-Write
4. Main address space  
The main address space is divided into 32 equally sized regions. Each region can be protected against write or erase operation. The 32-bit RUNLOCK register reflects the protection of each region. This register is automatically updated after power-up with the region lock user fuse data; To lock or unlock a region, the LR or UR commands can be issued.
  - Address: 0x00000000
  - Size: PARAM.NVMP pages.
  - Property: Read-Write
5. Bootloader space  
The bootloader section starts at the beginning of the main address space; Its size is defined by the BOOTPROT[3:0] fuse. It is protected against write or erase operations, except if STATUS.BPDIS is set. Issuing a write or erase command at an address inside the BOOTPROT section sets STATUS.PROGE and STATUS.LOCKE. STATUS.BPDIS can be set by issuing the Set BOOTPROT Disable command (SBPDIS). It is cleared by issuing the Clear BOOTPROT Disable command (CBPDIS). This allows to program a new bootloader without changing the user page and issuing a new NVMCTRL startup sequence to reload the user configuration. The BOOTPROT section is not erased during a Chip-Erase operation even if STATUS.BPDIS is high.
  - Address: 0x00000000
  - Size:  $(15 - \text{STATUS.BOOTPROT}) \times 8192$
  - Property: Read-Only.
6. SmartEEPROM raw data space  
The SmartEEPROM algorithm emulates an EEPROM with a portion of the NVM main. SmartEEPROM raw data is mapped at the end of the main address space. SmartEEPROM allocated space in the main address space is not accessible from AHB0/1. Any AHB access throws a

# SAM D5x/E5x Family Data Sheet

## NVMCTRL – Nonvolatile Memory Controller

hardfault exception. Any command issued with ADDR pointing in the SmartEEPROM space is discarded, INTFLAG.DONE and INTFLAG.ADDRE are set in this case.

- Address: PARAM.NVMP\*512-2\*SEESTAT.SBLK\*8192
- Size: 2\*SEESTAT.SBLK\*8192
- Property: Not readable, not writeable

Each section has different protection status, refer to the table below.

**Table 25-3. Protection status**

Section/Operation	Write protection	Erase protection	Chip-Erase protection
Bootloader	Yes	Yes	Yes
SmartEEPROM	Configurable	Configurable	No
Main Array	Configurable	Configurable	No

### Related Links

[9.2 Physical Memory Map](#)

[12. DSU - Device Service Unit](#)

### 25.6.3 Memory Bank Swapping

The two physical banks BANKA and BANKB are mapped in the NVM main address space and can be swapped. If STATUS.AFIRST contains '1', then BANKA is mapped to the NVM main address space Base Address, otherwise it is BANKB.

The start address of BANKA & BANKB depends on STATUS.AFIRST and on the size of the Flash. Refer to the Physical Memory Map for memory sizes and addresses for each device.

### Related Links

[9.2 Physical Memory Map](#)

### 25.6.4 AHBMUX Arbitration

The AHBMUX arbitrates concurrent AHB0, AHB1 and SmartEEPROM accesses using a fixed priority scheme:

- AHB0 has the highest priority
- AHB1 has priority over SmartEEPROM
- AHB2 has the lowest priority

However, once a transfer has been accepted the AHB data phase must complete, meaning that a transaction can be stalled by a previously granted access with a lower priority. This can occur in Automatic Wait State mode or in Fixed Wait State mode when the Wait state is greater than zero.

AHBMUX doesn't rearbitrate AHB burst transactions. This is useful in case of concurrent write transfers to the page buffer. If used in conjunction with the automatic write features (ADW, AQW, APW) and if the burst transfer size is a multiple of the automatic write size, several masters can write the NVM without implementing any software semaphore checks.

It is possible to force the rearbitration in case of burst transfers, as follows:

- on AHB0: by writing a '1' to CTRLA.AHBNS0
- on AHB1: by writing a '1' to CTRLA.AHBNS1

### Related Links

[10.3 High-Speed Bus System](#)

#### 25.6.5 Region Lock Bits

The NVM main address space is accessible through the AHB0 or AHB1 interfaces, and grouped into 32 equally sized regions regardless of BOOTPROT or SmartEEPROM settings. The region size is dependent on the flash memory size, and is given in the table below. Each region has a dedicated lock bit preventing writing and erasing pages in the region. After production, all regions will be unlocked.

**Table 25-4. Region Size**

Memory Size [KB]	Region Size [KB]
1024	32
512	16
256	8

To lock or unlock a region, the Lock Region and Unlock Region commands are provided. Writing one of these commands will temporarily lock/unlock the region containing the address loaded in the ADDR register. ADDR can be written by software, or the automatically loaded value from a AHB write operation can be used. The new setting will stay in effect until the next reset, or the setting can be changed again using the lock and unlock commands. The current status of the lock can be determined by reading the RUNLOCK register.

To change the default lock/unlock setting for a region, the user page must be written. Writing to the auxiliary space will take effect after the next reset. Therefore, a boot of the device is needed for changes in the lock/unlock setting to take effect. Refer to the Physical Memory Map for calibration and auxiliary space address mapping.

### Related Links

[9.2 Physical Memory Map](#)

#### 25.6.6 Command and Data Interface

The NVM Controller is addressable from the APB bus, while the NVM main address space is addressable from the AHB bus. Read and automatic page write operations are performed by addressing the NVM main address space directly, while other operations such as manual page writes and block erase must be performed by issuing commands through the NVM Controller.

To issue a command, the CTRLB.CMD bits must be written along with the CTRLB.CMDEX value. STATUS.READY is cleared when a command is issued and set when it has completed. Any command written while STATUS.READY is low will be ignored causing INTFLAG.PROGE to rise. Refer to CTRLB register description for more details.

Invalid commands are discarded and will set INTFLAG.PROGE and INTFLAG.DONE when issued.

The CTRLA register must be used to control the power reduction mode, read wait states and the write mode.

Commands that require an address use the ADDR register as an argument. ADDR APB write access is locked by the NVMCTRL while being used internally. For instance if a write operation is started by the NVMCTRL, an APB write is discarded so that the write operation is performed at the correct address. The discarded APB write is signaled by rising INTFLAG.ADDRE. Commands that needs an address will fail if issued while INTFLAG.ADDRE is set, such failure is signaled by rising INTFLAG.PROGE.

# SAM D5x/E5x Family Data Sheet

## NVMCTRL – Nonvolatile Memory Controller

The APB ADDR register is updated upon:

- APB writes to the ADDR register address
- AHB writes to the page buffer

ADDR APB writes are discarded and report an INTFLAG.ADDRE error in the following cases:

- When written from APB while a command is reading it.
- ADDR APB write access while writing the page buffer (AHB write): ADDR is written upon AHB writes and must stay valid until the page buffer has been written and also until automatic write command has been issued to the command interface when in automatic write mode (WMODE configured as ADW or AQW or AP).
- ADDR APB write access while the command interface reads it.
- A command is executed at an illegal address

All commands that require an address are discarded when INTFLAG.ADDRE is set. INTFLAG.PROGE is set in this case. INTFLAG.ADDRE must be cleared before issuing such commands.

### 25.6.6.1 NVM Read

Reading from the NVM main address space is performed via the AHB bus by addressing the NVM main address space or auxiliary address space directly. Read data is available after the number of read wait states has passed as configured in NVMCTRL.CTRLA.RWS.

The number of cycles data are delayed to the AHB bus is determined by the read wait states.

It is not possible to read two banks at the same time. In case of simultaneous read operations, transactions are arbitrated by the internal matrix. Arbitration scheme is fixed priority, AHB0 has the highest priority, AHB1 has priority over AHB2. In case of conflict, AHB interfaces with lower priority are stalled.

Reading in a bank stalls the bus when it is being programmed or erased except when the suspend feature is used.

Reading in a bank does not stall the bus when the other bank is being programmed or erased.

#### Related Links

[25.6.6.4 Suspend/Resume](#)

### 25.6.6.2 NVM Write

The entire NVM main address space except the BOOTPROT section can be erased by a debugger Chip Erase command. Alternatively, blocks or pages can be individually erased using the Erase Page (EP) or Erase Block (EB) depending on the targeted address space. The NVM can be programmed using the Write Page (WP) or Write Quad Word (WQW) commands depending on the targeted address space. AHB writes automatically update the ADDR register. ADDR is write locked by the NVMCTRL until the pagebuffer write completes or until the appropriate write command has been passed to the command interface when in automatic write mode. Write commands are not supported in all address spaces, see the table below. These commands are detailed further in this section.

**Table 25-5. Supported commands per address space**

	WP	WQW	EP	EB
Main Address Space	X	X		X

# SAM D5x/E5x Family Data Sheet

## NVMCTRL – Nonvolatile Memory Controller

.....continued				
	WP	WQW	EP	EB
User Page Address Space		X	X	

Issuing an unsupported command on an address space sets the PROGE interrupt flag.

After programming the NVM main array, the region that the page resides in can be locked to prevent spurious write or erase sequences. Locking is performed on a per-region basis, and so locking a region locks all pages inside the region.

Data to be written to the NVM block is written through AHB and stored in an internal buffer called the page buffer. If the NVMCTRL is busy processing a write command (STATUS.READY=0) then the AHB bus is stalled upon an AHB write until the ongoing command completes. Writing the page buffer is allowed during a block erase operation. The page buffer contains the same number of bytes as an NVM page. Writes to the page buffer must be 32 bits. 16-bit or 8-bit writes to the page buffer is not allowed, and will cause a PAC error. Internally, writes to the page buffer are on a 64-bit basis through the page buffer load data registers (PBLDATA[1] and PBLDATA[0]). The PBLDATA register is a holding register for writes to the same 64-bit page buffer section. Data within a 64-bit section can be written in any order. Crossing a 64-bit boundary will reset the PBLDATA register to all ones. The following example assumes startup from reset where the current address is 0 and PBLDATA is all ones. Only 64 bits of the page buffer are written at a time, but 128 bits are shown for reference.

### Sequential 32-bit write example:

- 32-bit 0x1 written to address 0
  - Page buffer[127:0] = {0xFFFFFFFF\_FFFFFFFF, PBLDATA[63:32], 0x00000001}
  - PBLDATA[63:0] = {PBLDATA[63:32], 0x00000001}
- 32-bit 0x2 written to address 1
  - Page buffer[127:0] = {0xFFFFFFFF\_FFFFFFFF, 0x00000002, PBLDATA[31:0]}
  - PBLDATA[63:0] = {0x00000002, PBLDATA[31:0]}
- 32-bit 0x3 written to address 2 (crosses 64-bit boundary)
  - Page buffer[127:0] = 0xFFFFFFFF\_00000003\_00000002\_00000001
  - PBLDATA[63:0] = 0xFFFFFFFF\_00000003

Random access writes to 32-bit words within the page buffer will overwrite the opposite word within the same 64-bit section with ones. In the following example, notice that 0x00000001 is overwritten with 0xFFFFFFFF from the third write due to the 64-bit boundary crossing. Only 64 bits of the page buffer are written at a time, but 128 bits are shown for reference.

### Random access 32-bit AHB write example:

- 32-bit 0x1 written to address 2
  - Page buffer[127:0] = 0xFFFFFFFF\_00000001\_FFFFFFFF\_FFFFFFFF
  - PBLDATA[63:0] = 0xFFFFFFFF\_00000001
- 32-bit 0x2 written to address 1
  - Page buffer[127:0] = 0xFFFFFFFF\_00000001\_00000002\_FFFFFFFF
  - PBLDATA[63:0] = 0x00000002\_FFFFFFFF
- 32-bit 0x3 written to address 3
  - Page buffer[127:0] = 0x00000003\_FFFFFFFF\_00000002\_FFFFFFFF

# SAM D5x/E5x Family Data Sheet

## NVMCTRL – Nonvolatile Memory Controller

---

- PBLDATA[63:0] = 0x00000003\_0xFFFFFFFF

BANKA and BANKB share the same page buffer. Writing to the NVM block via the AHB bus is buffered in the page buffer. For each AHB bus write, the address is stored in the ADDR register. After the page buffer has been loaded with the required number of bytes, the page can be written to the addressed location by setting CMD to Write Page to write the NVM main array and setting the key value to CMDEX. The LOAD bit in the STATUS register indicates whether the page buffer has been loaded or not. Before writing the page to memory, the accessed block must be erased.

Several write modes are supported and configured through CTRLA.WMODE.

- Manual (MAN):

This is the default configuration. Because the address is automatically stored in ADDR during AHB write operations, the last given address will be present in the ADDR register. There is no need to load the ADDR register manually, unless a different page in memory is to be written. A write should be issued before writing to a different page.

- Automatic Write With Double Word Granularity (ADW):

Automatically writes data with double-word granularity. In this case the WQW command is triggered at the quad-word addressed by ADDR when the last word in a double-word aligned block is written. The other double-word inside the page buffer must be all one. STATUS.READY goes low during the NVM write operation. INTFLAG.DONE flag is set upon completion.

- Automatic Write With Quad Word Granularity (AQW):

Automatically writes data with quad-word granularity. In this case the WQW command is triggered at the quad-word addressed by ADDR when the last word in a quad-word aligned block is written. STATUS.READY goes low during the NVM write operation. INTFLAG.DONE flag is set upon completion.

- Automatic Write With Page Granularity (AP)

Automatically writes data with page granularity. In this case the WP command is triggered at the page addressed by ADDR when the last word in a page aligned block is written. STATUS.READY goes low during the NVM write operation. INTFLAG.DONE flag is set upon completion.

These write modes are supported for writes in the main address space and in the USER page. The USER page doesn't support write page, if the AP mode is selected writes in the USER page will be done in AQW mode. This avoids to change WMODE by software while mixing writes in the main address space and in the USER page.

### Procedure for Manual Page Writes (WMODE=MAN)

The block to be written must be erased before the write command is given.

- Write to the page buffer by addressing the NVM main address space directly
- Write the page buffer to memory:
  - CMD=WP (and CMDEX) to write the full content of the page buffer into the NVM at the page pointed by ADDR
  - CMD=WQW (and CMDEX) to write into the NVM the page buffer quad word pointed by ADDR
- The READY bit in the STATUS register will be low while programming is in progress, and access through the AHB in the same bank will be stalled.

### Procedure for Automatic Writes (WMODE=ADW or AQW or APW)



# SAM D5x/E5x Family Data Sheet

## NVMCTRL – Nonvolatile Memory Controller

---

The block to be written must be erased before the last write to the page buffer is performed. The internal write operation will begin when the second word is written for WMODE = ADW, when the fourth word is written for WMODE = AQW, and when the last word of the page is written for WMODE = APW.

Note that partially written pages must be written with a manual write.

If the command interface is already processing a command, the AHB is stalled until the automatic write command is taken. Therefore it is possible to chain write commands without polling STATUS.READY. For applications that must not stall the AHB bus the automatic write must be used carefully: STATUS.READY must be checked after each double-word or quad-word or page buffer write depending on WMODE before chaining with a new write to avoid stalling the bus.

- Write to the page buffer by addressing the NVM main address space directly.
  - When the word location in the page buffer is written, the double word or quad word or page is automatically written to NVM main address space.
- STATUS.READY will be zero while programming is in progress and access through the AHB will be stalled.

### NVM Write Example (Manual Write mode)

1. Configure manual write for the NVM using WMODE (NVMCTRL.CTRLA).
2. Make sure the NVM is ready to accept a new command (NVMCTRL.STATUS).
3. Clear page buffer ( NVMCTRL.CTRLB).
4. Make sure NVM is ready to accept a new command (NVMCTRL.STATUS).
5. Clear the DONE Flag (NVMCTRL.INTFLAG).
6. Write data to page buffer with 32-bit accesses at the needed address.
7. Perform page write (NVMCTRL.CTRLB).
8. Make sure NVM is ready to accept a new command (NVMCTRL.STATUS).
9. Clear the DONE Flag (NVMCTRL.INTFLAG).

### 25.6.6.3 Read While Write (RWW)

This feature makes it possible to program and read the NVM simultaneously without stalling the AHB bus independently from any cache consideration. The basic principle is that NVM is made of two banks, one can be read while the other is programmed.

Limitations:

- It is not possible to read both banks simultaneously, reads will be prioritized and issued in series.
- It is not possible to program or erase both banks simultaneously, a new command will be accepted only after the completion of the previous one, otherwise the new command is ignored and INTFLAG.PROGE is set.
- RWW is not possible when reading or programming auxilliary pages, any read will result in an AHB stall and the command interface doesn't accept any command until completion of the previous one.

### 25.6.6.4 Suspend/Resume

This feature can be enabled by writing a '1' to CTRLA.SUSPEN. Any modify operation, such as write or erase can be suspended even those triggered by the SmartEEPROM.

When enabled, the following commands are suspended by a NVM read request:

- EB
- WP

# SAM D5x/E5x Family Data Sheet

## NVMCTRL – Nonvolatile Memory Controller

---

If a read occurs while executing one of the command listed above, the NVMCTRL will follow the following steps:

1. Send a suspend command to the NVM.
2. Wait for the NVM to be ready.
3. Read the NVM. The NVMCTRL will persist in this step when a new read request occurs, or else proceed.
4. Resume the suspended operation.

A suspend operation will set INTFLAG.SUSP. To clear it write a '1' to INTFLAG.SUSP.

The NVM suspended state is reflected in STATUS.SUSP.

Limitations:

- Suspend is not possible for a read in the page being programmed.
- Suspend is not possible for a read in a sector (128KB) containing a block under erase.
- It is not possible to enter power reduction mode when a command is suspended.

### 25.6.6.5 Page Buffer

The page buffer is automatically cleared to *all-ones* after any page write operation (WP or WQW command). If a partial page has been written and it is desired to clear the contents of the page buffer, the Page Buffer Clear (PBC) command can be used. The status of the page buffer is given by STATUS.LOAD. This bit indicates that the NVM page buffer has been loaded with one or more words. Immediately after an NVM load has been performed, this flag is set, and it remains set until a WP or WQW or a PBC command is given.

The Page Buffer cannot be written while a write command is executing in the NVM. Trying to do so stalls the AHB bus. To avoid stalling the AHB bus, STATUS.READY can be polled prior to issue a write command.

Clearing the page buffer also clears to all ones the PBLDATA0 and PBLDATA1.

### 25.6.6.6 Erase

Before a page can be written, it must be erased. The erase granularity depend on the address space (block or page). The Erase Block/Page command can be used to erase the desired block or page in the NVM main address space. Erasing the block/page sets all bits to '1'. If the block/page resides in a region that is locked, the erase will not be performed and the Lock Error bit in the INTFLAG register (INTFLAG.LOCKE) will be set. INTFLAG.PROGE will also be set since the command didn't complete. The Erase Page command can be issued on the USER page in the auxiliary space.

The procedure for an Erase Block/Page command is as follows:

- Write the address of the block/page to erase to ADDR. Any address within the block/page can be used.
- Issue an Erase Block/Page command.

The page buffer can be written while an erase page or erase block is being performed.

### 25.6.6.7 Lock and Unlock Region

The commands LR and UR are used to lock and unlock regions. These commands only update the RUNLOCK register but not the corresponding field in the user page.

#### Related Links

[25.6.5 Region Lock Bits](#)

[25.8.2 CTRLB](#)

### 25.6.6.8 Power Reduction Mode

The NVM implements a power reduction mode which cuts its static power consumption. If a command or a AHB access is issued the NVM is woken-up. The AHB access or the command are processed after the NVM wake-up time. The wake-up time can be reduced by enabling the PM fast wake-up feature, this is configured through the PM STDBYCFG register.

The NVM Power Reduction Mode is entered depending on the CTRLA.PRM mode:

- MANUAL:
  - Power Reduction Mode entering conditions:
    - SPRM command
  - Power Reduction Mode leaving conditions:
    - AHB access (read or write)
    - CPRM or any other command
- SEMIAUTO:
  - Power Reduction Mode entering conditions:
    - SPRM command
    - System enters standby mode
    - AHB access completes while in standby mode
    - Any command completes while in standby mode
  - Power Reduction Mode leaving conditions:
    - AHB access (read or write)
    - CPRM or any other command
- FULLAUTO:
  - Power Reduction Mode entering conditions:
    - SPRM command
    - System enters standby mode
    - AHB access completes while in standby mode
    - Any command completes while in standby mode
  - Power Reduction Mode leaving conditions:
    - AHB access (read or write)
    - CPRM or any other command
    - When the system leaves the standby mode

STATUS.READY is high when the NVM is in Power Reduction Mode indicating that the module can accept a command.

STATUS.PRM is high when the NVM is in Power Reduction Mode.

**Note:** It is not possible to enter power reduction mode when a command is suspended. Automatic power reduction entry is postponed until the command resumes and completes. The SPRM command is discarded when STATUS.SUSP is high and INTFLAG.PROGE is set.

#### Related Links

[18. PM – Power Manager](#)

[18.8.7 STDBYCFG](#)

### 25.6.7 Safe Flash Update Using Dual Banks

This feature enables a firmware to execute from the NVM and at the same time program the Flash with a new version of itself.

The new firmware has to be programmed in BANKB if STATUS.AFIRST=1, or BANKA otherwise.

After programming is completed one can issue the BKSWRST command to swap the banks and to reset the device. The information of which BANK is mapped to the NVM main address space base address is self contained in the NVM using a special fuse that can be programmed or erased individually. This fuse is managed by the BKSWRST command. STATUS.AFIRST reflects the status of this fuse after Reset. The BKSWRST command is atomic meaning that no fetch in the NVM can occur while executing this command. This command executes with the following steps:

1. Stall AHB interfaces.
2. If PARAM.SEE is '1' and  $0 < \text{SEESTAT.SBLK} < 11$ , the NVMCTRL starts to reallocate the SmartEEPROM data to the first bank. Active SEES remains the same at the end of the reallocation.
3. Is STATUS.AFIRST=1: program the AFIRST fuse (new value=0) otherwise erase it (new value=1)
4. Resets the device, After reset, RSTC RCAUSE indicates that the reset was triggered by the NVMCTRL.

After Reset the new firmware is executed from the last programmed bank.

If the SmartEEPROM is configured, the size of the the reserved space in flash must not exceed the bank size. In other words  $2 * \text{SEESTAT.SBLK} * 8192$  must be lower than half the NVM size in Bytes. In situations where both the banks contain separate applications (or an application in one bank and a bootloader in the other bank), both the banks must have Flash area reserved for SmartEEPROM. This means that the usable area for code in each bank is "Size of the Bank", that is, the size of the Flash configured for the SmartEEPROM using SBLK Fuse.

### 25.6.8 SmartEEPROM

#### 25.6.8.1 Principle of Operation

The SmartEEPROM feature is provided through the AHB2 interface and makes a portion of the NVM appear like a RAM. 8-bit, 16-bit, 32-bit access is supported.

The SmartEEPROM concept relies on the following NVM physical property: It is always possible to write a '0' in a NVM word, even if this word has been previously programmed - but it is not possible to write a '1' to a bit already programmed (holding a '0').

The algorithm consists of virtually mapping physical portions of the NVM to logical addresses with an indirection mechanism. A physical page is assigned to a virtual page address and is kept as long as no bit has to be flipped from '0' to '1', as this operation requires a full block erase. In case such a transition is required, a new physical page is assigned to the modified virtual page (placed in the Flash area reserved for the SmartEEPROM). Writing the virtual page affects the cycling endurance of the SmartEEPROM.

A region can overlap the SmartEEPROM region (depending on the allocated space for the SmartEEPROM), but SmartEEPROM is independent of the Region Lock Bits.

If NVMCTRL.STATUS.AFIRST contains '1', BANKA is mapped to the NVM main address space base address (0x0000). In this case, SmartEEPROM will be in BANKB. Conversely, when BANKB is mapped to the NVM main address space base address, SmartEEPROM will be in BANKA. Thus, the CPU is not halted when accessing the SmartEEPROM.

#### 25.6.8.2 Address Spaces

The SmartEEPROM address space is divided in two distinct areas:

- DATA
  - Starts at offset 0x0
  - Size is 512B, 1KB, 2KB, 4KB, 8KB, 16KB, 32KB, 64KB depending on SEESTAT.PSZ and SEESTAT.SBLK (refer to “SmartEEPROM virtual size”)
  - This area is write protected if SEESTAT.LOCK is set. SEESTAT.LOCK is non volatile.
  - Commands LSEE and USEE respectively lock and unlock the SmartEEPROM.
- REGISTER:
  - Starts at offset 0x10000
  - Size is 20B
  - This area is write protected if either
    - SEESTAT.LOCK is set (non-volatile)
    - SEESTAT.RLOCK is set (volatile).

Commands LSEER and USEER respectively lock and unlock the SmartEEPROM register address space.

As a consequence both SEESTAT.LOCK and SEESTAT.RLOCK must be low to write the SmartEEPROM register address space.

### Related Links

[25.6.8.4 SmartEEPROM Virtual Size](#)

#### 25.6.8.3 Data Structures

The SmartEEPROM algorithm relies on two virtual sectors (SEES) physically located in the last blocks of:

- BANKB if STATUS.AFIRST=1
- BANKA if STATUS.AFIRST=0

Only one SEES is active at a time, the other must be erased, ready for data reallocation.

The current active SEES is indicated in SEESTAT.ASEES:

- 0: SEES0 is active
- 1: SEES1 is active

SEESTAT.ASEES is loaded after Reset from a special fuse in the NVM which can be programmed or erased individually. This fuse can be set by issuing the ASEES1 command or cleared by issuing the ASEES0 command. SEESTAT.ASEES reflects this change immediately.

The maximum number of virtual pages is limited to 128.

A page allocation consists of assigning a SEEP to a virtual page for the first time. A page reallocation consists of assigning a new SEEP to an already existing virtual page. In both cases the selected virtual page index and the next available page are written.

The SEEP size (PSZ) is configurable. The number of blocks allocated per SEES is configurable.

#### 25.6.8.4 SmartEEPROM Virtual Size

The SmartEEPROM interface virtual size is the maximum amount of data that can be stored in it. This defines the maximum size of this interface. Trying to read or write outside the boundaries throws an hardfault exception.

The SBLK bits indicate the number of blocks allocated per SmartEEPROM virtual sector. The SmartEEPROM raw data resides in the upper blocks of the NVM main address space but is not accessible through AHB0 nor AHB1. The SmartEEPROM interface maximum size depends on SEESTAT.PSZ and SEESTAT.SBLK:

# SAM D5x/E5x Family Data Sheet

## NVMCTRL – Nonvolatile Memory Controller

**Table 25-6. SmartEEPROM Virtual Size in Bytes**

SEESTAT.PSZ: SEESTAT.SBLK	4	8	16	32	64	128	256	512
0	0	0	0	0	0	0	0	0
1	<b>512</b>	<b>1024</b>	<b>2048</b>	<b>4096</b>	4096	4096	4096	4096
2	<i>512</i>	<i>1024</i>	<i>2048</i>	<i>4096</i>	<b>8192</b>	8192	8192	8192
3	<i>512</i>	<i>1024</i>	<i>2048</i>	<i>4096</i>	<i>8192</i>	<b>16384</b>	16384	16384
4	<i>512</i>	<i>1024</i>	<i>2048</i>	<i>4096</i>	<i>8192</i>	<i>16384</i>	16384	16384
5	<i>512</i>	<i>1024</i>	<i>2048</i>	<i>4096</i>	<i>8192</i>	<i>16384</i>	<b>32768</b>	32768
6	<i>512</i>	<i>1024</i>	<i>2048</i>	<i>4096</i>	<i>8192</i>	<i>16384</i>	<i>32768</i>	32768
7	<i>512</i>	<i>1024</i>	<i>2048</i>	<i>4096</i>	<i>8192</i>	<i>16384</i>	<i>32768</i>	32768
8	<i>512</i>	<i>1024</i>	<i>2048</i>	<i>4096</i>	<i>8192</i>	<i>16384</i>	<i>32768</i>	32768
9	<i>512</i>	<i>1024</i>	<i>2048</i>	<i>4096</i>	<i>8192</i>	<i>16384</i>	<i>32768</i>	65536
10	<i>512</i>	<i>1024</i>	<i>2048</i>	<i>4096</i>	<i>8192</i>	<i>16384</i>	<i>32768</i>	<b>65536</b>

- The *italic* cells indicate sub-optimal configurations, unnecessary blocks are allocated.
- The **bold** cells indicate optimal valid configurations with the maximum number of SEEP depending on SEESTAT.PSZ and SEESTAT.SBLK (see the table below).
- Other cells indicate valid configurations with the maximum number of SEEP depending on SEESTAT.PSZ and SEESTAT.SBLK.

**Table 25-7. Maximum Number of SEEP depending on SEESTAT.PSZ and SEESTAT.SBLK**

SEESTAT.PSZ: SEESTAT.SBLK	4	8	16	32	64	128	256	512
0	N/A	N/A	N/A	N/A	N/A	N/A	N/A	N/A
1	144	144	144	144	<b>95</b>	<b>47</b>	<b>23</b>	<b>11</b>
2	144	144	144	144	144	<b>111</b>	<b>55</b>	<b>27</b>
3	144	144	144	144	144	144	<b>87</b>	<b>43</b>
4	144	144	144	144	144	144	<b>119</b>	<b>59</b>
5	144	144	144	144	144	144	144	<b>75</b>
6	144	144	144	144	144	144	144	<b>91</b>
7	144	144	144	144	144	144	144	<b>107</b>
8	144	144	144	144	144	144	144	<b>123</b>
9	144	144	144	144	144	144	144	<b>139</b>
10	144	144	144	144	144	144	144	144

### 25.6.8.5 SmartEEPROM wear leveling

The wear leveling factor is the minimum ratio per which the access frequency to a physical flash cell is divided when the maximum number of SEEP in a SEES is reached. This maximum number is depends

# SAM D5x/E5x Family Data Sheet

## NVMCTRL – Nonvolatile Memory Controller

on the SEESTAT.PSZ and SEESTAT.SBLK user configuration. As there are two SEES the wear leveling is two times the maximum SEEP number.

**Table 25-8. Wear leveling depending on SEESTAT.PSZ and SEESTAT.SBLK**

SEESTAT .PSZ: SEESTAT .SBLK	4	8	16	32	64	128	256	512
0	N/A	N/A	N/A	N/A	N/A	N/A	N/A	N/A
1	288	288	288	288	<b>190</b>	<b>94</b>	<b>46</b>	<b>22</b>
2	288	288	288	288	288	<b>222</b>	<b>110</b>	<b>54</b>
3	288	288	288	288	288	288	<b>174</b>	<b>86</b>
4	288	288	288	288	288	288	<b>238</b>	<b>118</b>
5	288	288	288	288	288	288	238	<b>150</b>
6	288	288	288	288	288	288	238	<b>182</b>
7	288	288	288	288	288	288	238	<b>214</b>
8	288	288	288	288	288	288	238	<b>246</b>
9	288	288	288	288	288	288	238	<b>278</b>
10	288	288	288	288	288	288	238	288

### 25.6.8.6 Writing and Reading the SmartEEPROM

SEESTAT.LOCK must be '0'; otherwise, writes are discarded and a hardfault exception is thrown. SmartEEPROM write access can be locked with the LSEE command and unlocked with the USEE command.

1. Configure SBLK and PSZ fuses to define the SmartEEPROM total size and size of each page.
2. Define a pointer to the SmartEEPROM area. It can be used for 8-, 16- or 32-bit access.

```
volatile uint8_t *SmartEEPROM8 = (uint8_t *) SEEPROM_ADDR; volatile uint16_t
*SmartEEPROM16 = (uint16_t *) SEEPROM_ADDR; volatile uint32_t *SmartEEPROM32 = (uint32_t
*) SEEPROM_ADDR;
```

3. Wait until SmartEEPROM is busy.

```
while (NVMCTRL->SEESTAT.bit.BUSY);
```

4. Write to the EEPROM like writing a RAM location. Perform an 8-, 16- or 32-bit write.
5. If automatic reallocation is disabled with SEECFG.APRDIS, check the SEESFULL interrupt flag to ensure that the active SmartEEPROM sector is not full.
6. To read back the content, read the location using the defined pointer.

```
uint8_t eep_data_8 = 0; while (NVMCTRL->SEESTAT.bit.BUSY); eep_data_8 = SmartEEPROM8[0];
```

There are two NVM pagebuffer management modes available, selected by writing the SEECFG.WMODE bit field:

- UNBUFFERED (default): WP command triggered after any pagebuffer update

# SAM D5x/E5x Family Data Sheet

## NVMCTRL – Nonvolatile Memory Controller

- **BUFFERED:** WP command triggered only in case of NVM page crossing. This mode increases the NVM wear-leveling but is more sensitive to power loss. SEESTAT.LOAD is high when the pagebuffer contains unwritten data.

When SEECFG.WMODE selects the buffered mode, the page buffer can contain unwritten SmartEEPROM data. This is reflected by SEESTAT.LOAD. To flush the SmartEEPROM data inside the page buffer, issue the SEEFLUSH command.

INTFLAG.SEEWRC indicates when a AHB write to the SmartEEPROM has completed:

1. Unbuffered mode: AHB write has completed, NVM is programmed with correct values except if INTFLAG.SEESOVF was thrown.
2. Buffered mode: AHB write has completed,
  - if SEESTAT.LOAD = 0: NVM is programmed with correct values, except if INTFLAG.SEESOVF was thrown.
  - otherwise; new data is in the page buffer, but is not yet programmed in the NVM.

### 25.6.8.7 SmartEEPROM Sector Reallocation

The SEES reallocation is performed by default in hardware when the the next available page in the master index reaches the maximum SEEP number. Automatic reallocation can be disabled by writing a one in SEECFG.APRDIS. The sector reallocation can also be triggered manually by issuing the SEERALOC command. The SEES reallocation process consists of:

- Erase the non active sector.
- Copying the active sector valid data to the other sector, old data is filtered.
- Swap ASEES either by issuing the ASEES1 command if SEESTAT.ASEES is reading '0' or by issuing the ASEES0 command if SEESTAT.ASEES is read as '1'.

This process is by default automatically handled by hardware, and indicated by the SEESTAT.BUSY flag. If in buffered mode, the page buffer must be flushed before triggering a reallocation; otherwise, the content of the pagebuffer would be lost.

**Note:** The BKSWRST command triggers automatically the reallocation algorithm which operates as described above except copy is done in the same active sector but in the first bank. This operation is atomic, meaning that no modify operation can be issued in the mean time.

As the total size of the whole SEEP exceeds the SmartEEPROM virtual size for a given configuration there is always free SEEP to replace existing data. In the case all addresses have been written, after sector reallocation the number of free SEEP is given in the following table.

**Table 25-9. Minimum number of free SEEP after sector reallocation**

SEESTAT .PSZ: SEESTAT .SBLK	4	8	16	32	64	128	256	512
0	N/A	N/A	N/A	N/A	N/A	N/A	N/A	N/A
1	16	16	16	16	31	15	7	3
2	16	16	16	16	16	47	23	11
3	16	16	16	16	16	16	23	11
4	16	16	16	16	16	16	55	27



# SAM D5x/E5x Family Data Sheet

## NVMCTRL – Nonvolatile Memory Controller

.....continued

SEESTAT .PSZ: SEESTAT .SBLK	4	8	16	32	64	128	256	512
5	16	16	16	16	16	16	16	11
6	16	16	16	16	16	16	16	27
7	16	16	16	16	16	16	16	43
8	16	16	16	16	16	16	16	59
9	16	16	16	16	16	16	16	11
10	16	16	16	16	16	16	16	16

### 25.6.9 NVM User Configuration

The NVM user configuration resides in the auxiliary space. Refer to the Physical Memory Map and Product Mapping of the device for calibration and auxiliary space address mapping.

The NVM user configuration is:

- The boot loader size. The bootloader resides in the main array starting at offset zero. The allocated boot loader section is protected against erase or write operations including the chip erase operation.
- The SmartEEPROM number of blocks per SEES (SBLK bits). This configuration is loaded after a reset into SEESTAT.SBLK bits.
- The SmartEEPROM virtual page size (PSZ bits). This configuration is loaded after a reset into SEESTAT.PSZ bits.
- The region lock bits (reflected in the RUNLOCK register)
- The SmartEEPROM RUNLOCK bit (reflected in SEESTAT.LOCK)

**Table 25-10. Boot Loader Size**

BOOTPROT [3:0]	Rows Protected by BOOTPROT	Boot Loader Size in KBytes
15	None	0
14	1	8
13	2	16
12	3	24
11	4	32
10	5	40
9	6	48
8	7	56
7	8	64
6	9	72
5	10	80

# SAM D5x/E5x Family Data Sheet

## NVMCTRL – Nonvolatile Memory Controller

.....continued

BOOTPROT [3:0]	Rows Protected by BOOTPROT	Boot Loader Size in KBytes
4	11	88
3	12	96
2	13	104
1	14	112
0	15	120

**Table 25-11. SmartEEPROM Allocated Space**

SBLK[4:0]	Total Blocks	Bytes
10	20	163840
9	18	147456
8	16	131072
7	14	114688
6	12	98304
5	10	81920
4	8	65536
3	6	49152
2	4	32768
1	2	16384
0	0	0

**Table 25-12. SmartEEPROM Virtual Page Size**

PSZ[2:0]	Page Size
7	512
6	256
5	128
4	64
3	32
2	16
1	8
0	4

### Related Links

[9.2 Physical Memory Map](#)

[8. Product Memory Mapping Overview](#)

### 25.6.10 Security Bit

The security bit allows the entire chip to be locked from external access for code security.

#### Related Links

[12. DSU - Device Service Unit](#)

#### 25.6.10.1 Security Bit Set Procedure

1. Issue the Set Security Bit command (SSB)  
This command changes the NVM security bits. The device shadow registers are not changed at that point. If a debugger was connected, it will still have access to the device after issuing this command (DSU.STATUSB.PROT will still read '0').
2. Check NVMNCTRL.INTFLAG.PROGE and NVMNCTRL.INTFLAG.DONE.
3. Reset the NVMCTRL peripheral or the device.

To reflect the NVM security bits' state correctly, the NVMCTRL needs to replay the start-up procedure. This is done by issuing a SWRST command or by resetting the device.

#### Related Links

[12. DSU - Device Service Unit](#)

#### 25.6.10.2 Security Bit Clear Procedure

The only way to clear the security bit is through a debugger Chip Erase command. The NVM security bit is cleared after all internal volatile and NVM have been cleared. The device protection status is updated at the end of the command meaning that no reset is necessary.

#### Related Links

[12. DSU - Device Service Unit](#)

### 25.6.11 Line Cache

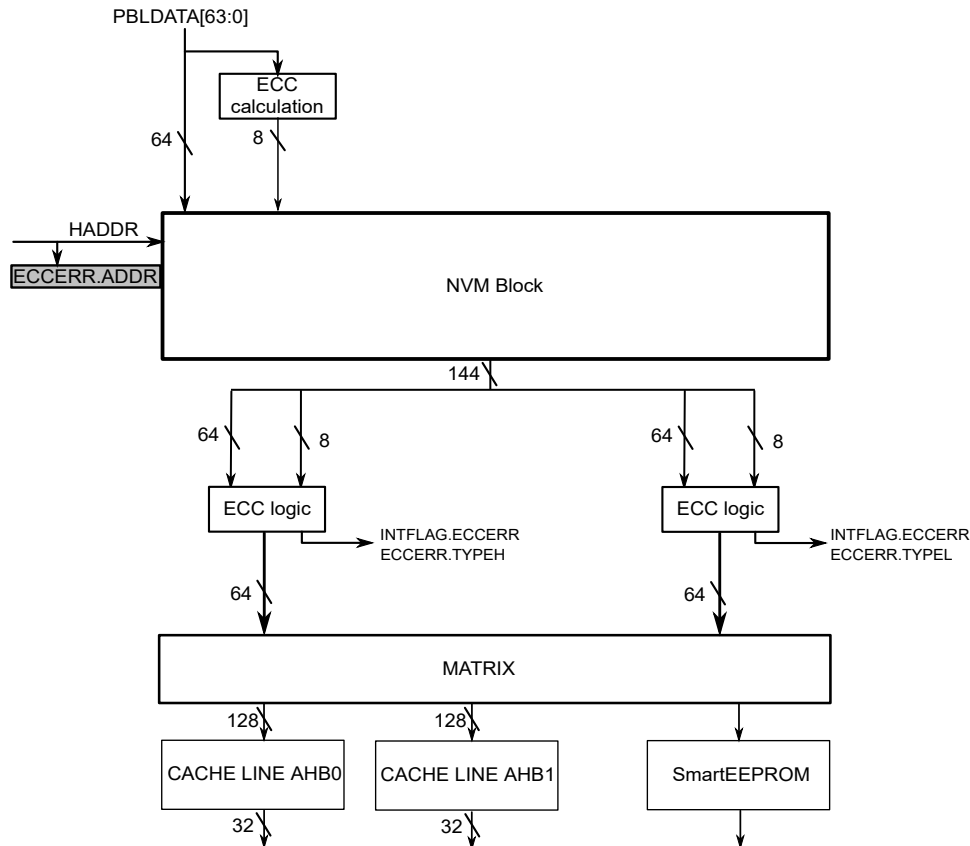
NVM reads 128-bit at a time. AHB0 and AHB1 interfaces implement each a 128-bit cache line. This reduces the device power consumption when reading continuous data and improves system performance when wait states are required. Line cache are enabled by default and can be individually disabled per AHB interface by writing a one in the CACHEDIS[0] or CACHEDIS[1] bit in the CTRLA register (CTRLA.CACHEDIS[1:0]). Refer to CTRLA register description for more details. Commands affecting NVM content automatically invalidate cache lines.

### 25.6.12 Error Correction Code (ECC)

Error Correcting Code (ECC) is implemented to detect and correct errors that may arise in the NVM array. ECC is by default enabled and cannot be disabled by the user.

### 25.6.12.1 Block Diagram

**Figure 25-2. ECC Diagram**



Note that the ECC correction is disabled when access is performed by the SmartEEPROM interface.

### 25.6.12.2 ECC Error Detection

The NVM physical block fetches 128-bit quad-word and ECC checking is performed on a 64-bit basis independently on the low and high double-words. Therefore two ECC decoders operate in parallel. An ECC failure may be present in any of the four words from the NVM, not necessarily the word that is addressed on the bus. Any ECC error in a double-word will be reported the first time the quad-word access. The ECC logic in the read data path is capable of double error detection and single error correction on the fly per 64-bit double-word.

Upon detection:

- INTFLAG ECC error flags are updated:
  - The ECC single error interrupt flag is raised (**INTFLAG.ECCSE**) in case of single error
  - The ECC dual error interrupt flag is raised (**INTFLAG.ECCDE**) in case of dual error
- **ECCERR.ADDR** is updated with the faulty quad-word byte address in the main address space.
- **ECCERR.TYPEL** is updated with the error type (**NONE**, **SINGLE**, **DUAL**) detected on the low 64-bit double word.
- **ECCERR.TYPEH** is updated with the error type (**NONE**, **SINGLE**, **DUAL**) detected on the high 64-bit double word.

**INTFLAG.ECCSE** and **INTFLAG.ECCDE** are automatically cleared when **ECCERR** is read.

# SAM D5x/E5x Family Data Sheet

## NVMCTRL – Nonvolatile Memory Controller

---

ECCERR.TYPEL and ECCERR.TYPEH are reset to the NONE value when ECCERR is read. If an error occurs while reading ECCERR, the previous error information is sent to the APB and ECCERR is updated with the next error information.

If a single-error has been detected and INTFLAG.ECCSE or INTFLAG.ECCDE is not clear:

- Any incoming single-errors is ignored
- First incoming dual-error overrides ECCERR.ADDR, ECCERR.TYPEL and ECCERR.TYPEH

If a dual-error has been detected and INTFLAG.ECCDE is not clear:

- incoming single-errors are ignored
- incoming dual-errors are ignored

ECCERR.ADDR is always quad-word aligned. If jumping to a word that is not quad-word aligned, e.g. jumping to address 0x100C, INTFLAG.ECCDE and INTFLAG.ECCSE are updated according to the types of detected errors, and ECCERR.ADDR will read 0x1000, irrespective of whether the ECC error was in address 0x1000, 0x1004, 0x1008, or 0x100C.

### 25.6.13 Reset During Operation

Program or erase operations must not be interrupted. The content of a block or a page is unpredictable in case of reset during either an erase or a write operation. To reduce the risk of having a BOD reset due to a power loss one can monitor the external voltage before issuing any program or erase operation. The user can also prefer the WQW command instead of the WP command as a short command is more likely to complete successfully than a long one with a given external decoupling capacitor. In case of reset during a write or erase operation the impacted block must be erased before being read or programmed as its content is unknown.

### 25.6.14 Chip Erase

The Chip Erase operation is system-wide, and issued through the DSU.

Chip-Erase procedure:

1. Volatile memories are cleared and NVM array is erased simultaneously (except the BOOTPROT section)
2. Special individual fuses are set as follow:
  - If no BOOTPROT section is defined then NVMCTRL.STATUS.AFIRST=1 otherwise it is left unchanged
  - NVMCTRL.SEESTAT.ASEES=1
  - NVMCTRL.SEESTAT.LOCK=0
  - DSU.STATUSB.CELCK=0
3. Security bit is cleared provided no internal error has been detected in the previous steps
  - If all internal NVM verify operations succeeded: goto 4
  - otherwise set DSU.STATUSA.DONE and DSU.STATUSA.FAIL and exit.
4. DSU.STATUSB.PROT is cleared, system is no more protected

**Note:** CB, FS, USER pages (in the auxiliary address space) and the section allocated as a boot loader using BOOTPROT are not affected by the Chip-Erase operation.

# SAM D5x/E5x Family Data Sheet

## NVMCTRL – Nonvolatile Memory Controller

### 25.7 Register Summary

Offset	Name	Bit Pos.								
0x00	CTRLA	7:0	PRM[1:0]		WMODE[1:0]		SUSPEN	AUTOWS		
		15:8	CACHEDIS1	CACHEDIS0	AHBNS1	AHBNS0	RWS[3:0]			
0x02 ... 0x03	Reserved									
0x04	CTRLB	7:0	CMD[6:0]							
		15:8	CMDEX[7:0]							
0x06 ... 0x07	Reserved									
0x08	PARAM	7:0	NVMP[7:0]							
		15:8	NVMP[15:8]							
		23:16	PSZ[2:0]							
		31:24	SEE							
0x0C	INTENCLR	7:0	SUSP	NVME	ECCDE	ECCSE	LOCKE	PROGE	ADDRE	DONE
		15:8						SEEWRC	SEESOVF	SEESFULL
0x0E	INTENSET	7:0	SUSP	NVME	ECCDE	ECCSE	LOCKE	PROGE	ADDRE	DONE
		15:8						SEEWRC	SEESOVF	SEESFULL
0x10	INTFLAG	7:0	SUSP	NVME	ECCDE	ECCSE	LOCKE	PROGE	ADDRE	DONE
		15:8						SEEWRC	SEESOVF	SEESFULL
0x12	STATUS	7:0			BPDIS	AFIRST	SUSP	LOAD	PRM	READY
		15:8						BOOTPROT[3:0]		
0x14	ADDR	7:0	ADDR[7:0]							
		15:8	ADDR[15:8]							
		23:16	ADDR[23:16]							
		31:24								
0x18	RUNLOCK	7:0	RUNLOCK[7:0]							
		15:8	RUNLOCK[15:8]							
		23:16	RUNLOCK[23:16]							
		31:24	RUNLOCK[31:24]							
0x1C	PBLDATA <sub>n0</sub>	7:0	DATA[7:0]							
		15:8	DATA[15:8]							
		23:16	DATA[23:16]							
		31:24	DATA[31:24]							
0x20	PBLDATA <sub>n1</sub>	7:0	DATA[7:0]							
		15:8	DATA[15:8]							
		23:16	DATA[23:16]							
		31:24	DATA[31:24]							
0x24	ECCERR	7:0	ADDR[7:0]							
		15:8	ADDR[15:8]							
		23:16	ADDR[23:16]							
		31:24	TYPEH[1:0]		TYPEL[1:0]					
0x28	DBGCTRL	7:0						ECCELOG	ECCDIS	

# SAM D5x/E5x Family Data Sheet

## NVMCTRL – Nonvolatile Memory Controller

.....continued

Offset	Name	Bit Pos.								
0x29	Reserved									
0x2A	SEECFG	7:0							APRDIS	WMODE
0x2B	Reserved									
0x2C	SEESTAT	7:0				RLOCK	LOCK	BUSY	LOAD	ASEES
		15:8				SBLK[3:0]				
		23:16				PSZ[2:0]				
		31:24								

### 25.8 Register Description

Registers can be 8, 16, or 32 bits wide. Atomic 8-, 16-, and 32-bit accesses are supported. In addition, the 8-bit quarters and 16-bit halves of a 32-bit register, and the 8-bit halves of a 16-bit register can be accessed directly.

Some registers require synchronization when read and/or written. Synchronization is denoted by the "Read-Synchronized" and/or "Write-Synchronized" property in each individual register description.

Some registers are enable-protected, meaning they can only be written when the module is disabled. Enable protection is denoted by the "Enable-Protected" property in each individual register description.

# SAM D5x/E5x Family Data Sheet

## NVMCTRL – Nonvolatile Memory Controller

### 25.8.1 Control A

**Name:** CTRLA  
**Offset:** 0x0  
**Reset:** 0x0004  
**Property:** PAC Write-Protection

Bit	15	14	13	12	11	10	9	8
	CACHEDIS1	CACHEDIS0	AHBNS1	AHBNS0	RWS[3:0]			
Access	R/W	R/W	R/W	R/W	R/W	R/W	R/W	R/W
Reset	0	0	0	0	0	0	0	0
Bit	7	6	5	4	3	2	1	0
	PRM[1:0]		WMODE[1:0]		SUSPEN	AUTOWS		
Access	R/W	R/W	R/W	R/W	R/W	R/W		
Reset	0	0	0	0	0	1		

**Bit 15 – CACHEDIS1** AHB1 Cache Disable

AHB1 interface cache disable.

0: cache line is enabled

1: cache line is disabled

Cache lines are automatically invalidated when a write or erase operation is started in the NVM.

**Bit 14 – CACHEDIS0** AHB0 Cache Disable

AHB0 interface cache disable.

0: cache line is enabled

1: cache line is disabled

Cache lines are automatically invalidated when a write or erase operation is started in the NVM.

**Bit 13 – AHBNS1** Force AHB1 access to Non-Sequential

This bit forces AHB1 communication to be non-sequential.

Value	Description
0	AHB sequential accesses remain sequential.
1	AHB sequential accesses are forced to non-sequential, therefore forcing re arbitration for each access.

**Bit 12 – AHBNS0** Force AHB0 access to Non-Sequential

This bit forces AHB0 communication to be non-sequential.

Value	Description
0	AHB sequential accesses remain sequential.
1	AHB sequential accesses are forced to non-sequential, therefore forcing re arbitration for each access.

**Bits 11:8 – RWS[3:0]** NVM Read Wait States

These bits give the number of wait states for a read operation when AUTOWS=0. Zero indicates zero wait states, one indicates one wait state, etc., up to 15 wait states.

This register is initialized to 0 wait states. Software can change this value based on the NVM access time and system frequency.



# SAM D5x/E5x Family Data Sheet

## NVMCTRL – Nonvolatile Memory Controller

### Bits 7:6 – PRM[1:0] Power Reduction Mode during Sleep

Indicates the power reduction mode during sleep.

Value	Name	Description
0x0	SEMIAUTO	NVM block enters low-power mode when entering standby mode. NVM block enters low-power mode when SPRM command is issued. NVM block exits low-power mode upon first access.
0x1	FULLAUTO	NVM block enters low-power mode when entering standby mode. NVM block enters low-power mode when SPRM command is issued. NVM block exits low-power mode when system is not in standby mode.
0x2		Reserved
0x3	MANUAL	NVM block does not enter low-power mode when entering standby mode. NVM block enters low-power mode when SPRM command is issued. NVM block exits low-power mode upon first access.

### Bits 5:4 – WMODE[1:0] Write Mode

Write commands can be generated automatically when crossing address boundaries while writing to the NVM. Boundaries depend on the settings below.

Value	Name	Description
0x0	MAN	Manual Write
0x1	ADW	Automatic Double Word Write
0x2	AQW	Automatic Quad Word
0x3	AP	Automatic Page Write

### Bit 3 – SUSPEN Suspend Enable

0: The write and erase suspend resume feature is disabled.

1: A write or erase operation can be suspended in case of a read in the same bank.

### Bit 2 – AUTOWS Auto Wait State Enable

0: Automatic wait state generation is disabled. The number of wait states used is given by RWS.

1: Automatic wait state generation is enabled. The number of wait states used is automatically detected therefore the module can operate at any frequency up to the device maximum frequency. A minimum of one cycle latency is induced.

# SAM D5x/E5x Family Data Sheet

## NVMCTRL – Nonvolatile Memory Controller

### 25.8.2 Control B

**Name:** CTRLB  
**Offset:** 0x04  
**Reset:** 0x0000  
**Property:** PAC Write-Protection

	Bit	15	14	13	12	11	10	9	8
		CMDEX[7:0]							
Access		PAC Write- Protection	PAC Write- Protection	PAC Write- Protection	PAC Write- Protection	PAC Write- Protection	PAC Write- Protection	PAC Write- Protection	PAC Write- Protection
Reset		0	0	0	0	0	0	0	0
Bit		7	6	5	4	3	2	1	0
		CMD[6:0]							
Access			W	W	W	W	W	W	W
Reset			0	0	0	0	0	0	0

#### Bits 15:8 – CMDEX[7:0] Command Execution

This bit group should be written with the key value 0xA5 to enable the command written to CMD to be executed. If the bit group is written with a different key value, the write is not performed and INTFLAG.PROGE is set. PROGE is also set if the a previously written command is not complete.

The key value must be written at the same time as CMD. If a command is issued through the APB bus on the same cycle as an AHB bus access, the AHB bus access will be given priority. The command will then be executed when the NVM block and the AHB bus are idle.

STATUS.READY must be one when the command is issued.

INTFLAG.DONE is set when the command completes.

Value	Name	Description
0xA5	KEY	Execution Key
Other	-	Reserved

#### Bits 6:0 – CMD[6:0] Command

These bits define the command to be executed when the CMDEX key is written.

Value	Name	Description
0x0	EP	Erase Page - Only supported in the User page in the auxiliary space.
0x1	EB	Erase Block - Erases the block addressed by the ADDR register, not supported in the user page
0x2		Reserved
0x3	WP	Write Page - Writes the contents of the page buffer to the page addressed by the ADDR register, not supported in the user page
0x4	WQW	Write Quad Word - Writes a 128-bit word at the location addressed by the ADDR register.
0x5-0xF		Reserved
0x10	SWRST	Software Reset - Power-Cycle the NVM memory and replay the device automatic calibration procedure and resets the module configuration registers
0x11	LR	Lock Region - Locks the region containing the address location in the ADDR register until next reset.

# SAM D5x/E5x Family Data Sheet

## NVMCTRL – Nonvolatile Memory Controller

Value	Name	Description
0x12	UR	Unlock Region - Unlocks the region containing the address location in the ADDR register until next reset.
0x13	SPRM	Sets the power reduction mode.
0x14	CPRM	Clears the power reduction mode.
0x15	PBC	Page Buffer Clear - Clears the page buffer.
0x16	SSB	Set Security Bit
0x17	BKSWRST	Bank swap and system reset, if SmartEEPROM is used also reallocate its data into the opposite BANK
0x18	CELCK	Chip Erase Lock - DSU.CTRL.CE command is not available
0x19	CEULCK	Chip Erase Unlock - DSU.CTRL.CE command is available
0x1A	SBPDIS	Sets STATUS.BPDIS, Boot loader protection is discarded until CBPDIS is issued or next start-up sequence
0x1B	CBPDIS	Clears STATUS.BPDIS, Boot loader protection is not discarded
0x1C-0x2F		Reserved
0x30	ASEES0	Configure SmartEEPROM to use Sector 0
0x31	ASEES1	Configure SmartEEPROM to use Sector 1
0x32	SEERALOC	Starts SmartEEPROM sector reallocation algorithm
0x33	SEEFLUSH	Flush SmartEEPROM data when in buffered mode
0x34	LSEE	Lock access to SmartEEPROM data from any means
0x35	USEE	Unlock access to SmartEEPROM data
0x36	LSEER	Lock access to the SmartEEPROM Register Address Space (above 64KB)
0x37	USEER	Unock access to the SmartEEPROM Register Address Space (above 64KB)
0x38-0x7F		Reserved

# SAM D5x/E5x Family Data Sheet

## NVMCTRL – Nonvolatile Memory Controller

### 25.8.3 NVM Parameter

**Name:** PARAM  
**Offset:** 0x08  
**Property:** -

Bit	31	30	29	28	27	26	25	24	
	SEE								
Access	R								
Reset									
Bit	23	22	21	20	19	18	17	16	
							PSZ[2:0]		
Access							R	R	R
Reset									
Bit	15	14	13	12	11	10	9	8	
	NVMP[15:8]								
Access	R	R	R	R	R	R	R	R	
Reset									
Bit	7	6	5	4	3	2	1	0	
	NVMP[7:0]								
Access	R	R	R	R	R	R	R	R	
Reset									

**Bit 31 – SEE** SmartEEPROM Supported  
0: No SmartEEPROM support  
1: SmartEEPROM is supported.

**Bits 18:16 – PSZ[2:0]** Page Size

Indicates the page size. Not all device families will provide all the page sizes indicated in the table.

Value	Name	Description
0x0	8	8 bytes
0x1	16	16 bytes
0x2	32	32 bytes
0x3	64	64 bytes
0x4	128	128 bytes
0x5	256	256 bytes
0x6	512	512 bytes
0x7	1024	1024 bytes

**Bits 15:0 – NVMP[15:0]** NVM Pages

Indicates the number of pages in the NVM main address space

# SAM D5x/E5x Family Data Sheet

## NVMCTRL – Nonvolatile Memory Controller

### 25.8.4 Interrupt Enable Clear

**Name:** INTENCLR  
**Offset:** 0x0C  
**Reset:** 0x0000  
**Property:** PAC Write-Protection

	15	14	13	12	11	10	9	8
						SEEWRC	SEESOVF	SEESFULL
Access						R/W	R/W	R/W
Reset						0	0	0
	7	6	5	4	3	2	1	0
	SUSP	NVME	ECCDE	ECCSE	LOCKE	PROGE	ADDRE	DONE
Access	R/W	R/W	R/W	R/W	R/W	R/W	R/W	R/W
Reset	0	0	0	0	0	0	0	0

**Bit 10 – SEEWRC** SEE Write Completed Interrupt Clear  
 Writing a zero to this bit has no effect.  
 Writing a '1' to this bit clears the SEEWRC interrupt enable.  
 This bit will read as the current value of the SEEWRC interrupt enable.

**Bit 9 – SEESOVF** Active SEES Overflow Interrupt Clear  
 Writing a zero to this bit has no effect.  
 Writing a '1' to this bit clears the SEESOVF interrupt enable.  
 This bit will read as the current value of the SEESOVF interrupt enable.

**Bit 8 – SEESFULL** Active SEES Full Interrupt Clear  
 Writing a zero to this bit has no effect.  
 Writing a '1' to this bit clears the SEESFULL interrupt enable.  
 This bit will read as the current value of the SEESFULL interrupt enable.

**Bit 7 – SUSP** Suspended Write Or Erase Interrupt Clear  
 Writing a zero to this bit has no effect.  
 Writing a '1' to this bit clears the SUSP interrupt enable.  
 This bit will read as the current value of the SUSP interrupt enable.

**Bit 6 – NVME** NVM Error Interrupt Clear  
 Writing a zero to this bit has no effect.  
 Writing a '1' to this bit clears the NVME interrupt enable.  
 This bit will read as the current value of the NVME interrupt enable.

**Bit 5 – ECCDE** ECC Dual Error Interrupt Clear  
 Writing a zero to this bit has no effect.  
 Writing a '1' to this bit clears the ECCDE interrupt enable.  
 This bit will read as the current value of the ECCDE interrupt enable.

**Bit 4 – ECCSE** ECC Single Error Interrupt Clear  
 Writing a zero to this bit has no effect.

# SAM D5x/E5x Family Data Sheet

## NVMCTRL – Nonvolatile Memory Controller

---

Writing a '1' to this bit clears the ECCSE interrupt enable.  
This bit will read as the current value of the ECCSE interrupt enable.

### **Bit 3 – LOCKE** Lock Error Interrupt Clear

Writing a zero to this bit has no effect.  
Writing a '1' to this bit clears the LOCKE interrupt enable.  
This bit will read as the current value of the LOCKE interrupt enable.

### **Bit 2 – PROGE** Programming Error Interrupt Clear

Writing a zero to this bit has no effect.  
Writing a '1' to this bit clears the PROGE interrupt enable.  
This bit will read as the current value of the PROGE interrupt enable.

### **Bit 1 – ADDRE** Address Error Interrupt Clear

Writing a zero to this bit has no effect.  
Writing a '1' to this bit clears the ADDRE interrupt enable.  
This bit will read as the current value of the ADDRE interrupt enable.

### **Bit 0 – DONE** Command Done Interrupt Clear

Writing a zero to this bit has no effect.  
Writing a '1' to this bit clears the DONE interrupt enable.  
This bit will read as the current value of the DONE interrupt enable.

# SAM D5x/E5x Family Data Sheet

## NVMCTRL – Nonvolatile Memory Controller

### 25.8.5 Interrupt Enable Set

**Name:** INTENSET  
**Offset:** 0x0E  
**Reset:** 0x0000  
**Property:** PAC Write-Protection

	15	14	13	12	11	10	9	8
						SEEWRC	SEESOVF	SEESFULL
Access						R/W	R/W	R/W
Reset						0	0	0
	7	6	5	4	3	2	1	0
	SUSP	NVME	ECCDE	ECCSE	LOCKE	PROGE	ADDRE	DONE
Access	R/W	R/W	R/W	R/W	R/W	R/W	R/W	R/W
Reset	0	0	0	0	0	0	0	0

**Bit 10 – SEEWRC** SEE Write Completed Interrupt Enable  
 Writing a zero to this bit has no effect.  
 Writing a one to this bit sets the SEEWRC interrupt enable.  
 This bit will read as the current value of the SEEWRC interrupt enable.

**Bit 9 – SEESOVF** Active SEES Overflow Interrupt Enable  
 Writing a zero to this bit has no effect.  
 Writing a one to this bit sets the SEESOVF interrupt enable.  
 This bit will read as the current value of the SEESOVF interrupt enable.

**Bit 8 – SEESFULL** Active SEES Full Interrupt Enable  
 Writing a zero to this bit has no effect.  
 Writing a one to this bit sets the SEESFULL interrupt enable.  
 This bit will read as the current value of the SEESFULL interrupt enable.

**Bit 7 – SUSP** Suspended Write Or Erase Interrupt Enable  
 Writing a zero to this bit has no effect.  
 Writing a one to this bit sets the SUSP interrupt enable.  
 This bit will read as the current value of the SUSP interrupt enable.

**Bit 6 – NVME** NVM Error Interrupt Enable  
 Writing a zero to this bit has no effect.  
 Writing a one to this bit sets the NVME interrupt enable.  
 This bit will read as the current value of the NVME interrupt enable.

**Bit 5 – ECCDE** ECC Dual Error Interrupt Enable  
 Writing a zero to this bit has no effect.  
 Writing a one to this bit sets the ECCDE interrupt enable.  
 This bit will read as the current value of the ECCDE interrupt enable.

**Bit 4 – ECCSE** ECC Single Error Interrupt Enable  
 Writing a zero to this bit has no effect.

# SAM D5x/E5x Family Data Sheet

## NVMCTRL – Nonvolatile Memory Controller

---

Writing a one to this bit sets the ECCSE interrupt enable.  
This bit will read as the current value of the ECCSE interrupt enable.

### **Bit 3 – LOCKE** Lock Error Interrupt Enable

Writing a zero to this bit has no effect.  
Writing a one to this bit sets the LOCKE interrupt enable.  
This bit will read as the current value of the LOCKE interrupt enable.

### **Bit 2 – PROGE** Programming Error Interrupt Enable

Writing a zero to this bit has no effect.  
Writing a one to this bit sets the PROGE interrupt enable.  
This bit will read as the current value of the PROGE interrupt enable.

### **Bit 1 – ADDRE** Address Error Interrupt Enable

Writing a zero to this bit has no effect.  
Writing a one to this bit sets the ADDRE interrupt enable.  
This bit will read as the current value of the ADDRE interrupt enable.

### **Bit 0 – DONE** Command Done Interrupt Enable

Writing a zero to this bit has no effect.  
Writing a one to this bit sets the DONE interrupt enable.  
This bit will read as the current value of the DONE interrupt enable.



# SAM D5x/E5x Family Data Sheet

## NVMCTRL – Nonvolatile Memory Controller

### 25.8.6 Interrupt Flag Status and Clear

**Name:** INTFLAG  
**Offset:** 0x10  
**Reset:** 0x0000  
**Property:** -

	15	14	13	12	11	10	9	8
						SEEWRC	SEESOVF	SEESFULL
Access						R/W	R/W	R/W
Reset						0	0	0
	7	6	5	4	3	2	1	0
	SUSP	NVME	ECCDE	ECCSE	LOCKE	PROGE	ADDRE	DONE
Access	R/W	R/W	R	R	R/W	R/W	R/W	R/W
Reset	0	0	0	0	0	0	0	0

#### Bit 10 – SEEWRC SEE Write Completed

- Unbuffered mode:
    - 0: AHB write is pending.
    - 1: AHB write has completed, and NVM is programmed with correct values.
  - Buffered mode:
    - 0: AHB write is pending.
    - 1: AHB write has completed.
- If SEESTAT.LOAD=0, then the NVM is programmed with correct values.  
 If SEESTAT.LOAD=1, then data is still pending in the Page Buffer.

#### Bit 9 – SEESOVF Active SEES Overflow

0: No SEES overflow have been detected since the last clear.  
 1: At least SEES overflow has been detected since the last clear.  
 This bit can be cleared by writing a one to its bit location.

#### Bit 8 – SEESFULL Active SEES Full

0: The active SEES is not full  
 1: The active SEES is Full, meaning that the next write will fail if the active sector is not reallocated.  
 This bit can be cleared by writing a one to its bit location.

#### Bit 7 – SUSP Suspended Write Or Erase Operation

0: No write/suspend has occurred since the last clear.  
 1: A write or erase operation has been suspended since the last clear.  
 This bit can be cleared by writing a one to its bit location.

#### Bit 6 – NVME NVM Error

0: No NVM errors have been received since the last clear.  
 1: At least one NVM error has occurred since the last clear.  
 This bit can be cleared by writing a one to its bit location.

# SAM D5x/E5x Family Data Sheet

## NVMCTRL – Nonvolatile Memory Controller

---

### **Bit 5 – ECCDE** ECC Dual Error

0: No ECC dual errors have been received since the last ECCERR register read.

1: At least one ECC error has occurred since the last ECCERR register read.

This bit is cleared when the ECCERR register is read.

### **Bit 4 – ECCSE** ECC Single Error

0: No ECC single errors have been received since the last ECCERR register read.

1: At least one ECC error has occurred since the last ECCERR register read.

This bit is cleared when the ECCERR register is read.

### **Bit 3 – LOCKE** Lock Error

0: No LOCK errors have been received since the last clear.

1: At least one LOCK error has occurred since the last clear.

This bit can be cleared by writing a one to its bit location.

### **Bit 2 – PROGE** Programming Error

0: No PROG errors have been received since the last clear.

1: At least one PROG error has occurred since the last clear.

This bit can be cleared by writing a one to its bit location.

### **Bit 1 – ADDRE** Address Error

0: No ADDRE error has been detected since the last clear.

1: At least one ADDRE error has been detected since the last clear.

This bit can be cleared by writing a one to its bit location.

### **Bit 0 – DONE** Command Done

0: The NVM controller has not completed any command since the last clear.

1: At least one command has completed since the last clear.

This bit can be cleared by writing a one to its bit location.

# SAM D5x/E5x Family Data Sheet

## NVMCTRL – Nonvolatile Memory Controller

### 25.8.7 Status

**Name:** STATUS  
**Offset:** 0x12  
**Reset:** 0x0000  
**Property:** Read-Only

	Bit	15	14	13	12	11	10	9	8
		BOOTPROT[3:0]							
Access						R	R	R	R
Reset						0	0	0	x
	Bit	7	6	5	4	3	2	1	0
				BPDIS	AFIRST	SUSP	LOAD	PRM	READY
Access				R	R	R	R	R	R
Reset				0	0	0	0	0	0

**Bits 11:8 – BOOTPROT[3:0]** Boot Loader Protection Size

This bitfield is loaded from the USER page during the device startup. Defines the size of the BOOTPROT region which is protected against write or erase or Chip-Erase operations. This size is given by the following formula (15-BOOTPROT)\*8KB.

**Bit 5 – BPDIS** Boot Loader Protection Disable

0: Boot loader protection is not discarded.  
 1: Boot loader protection against modify operations is discarded until CBPDIS is issued or next start-up sequence except for Chip-Erase.

**Bit 4 – AFIRST** BANKA First

0: Start address of bank B is mapped at 0x0000\_0000.  
 1: Start address of bank A is mapped at 0x0000\_0000.

**Bit 3 – SUSP** NVM Write Or Erase Operation Is Suspended

0: The NVM controller is not in suspended state.  
 1: The NVM controller is in suspended state.

**Bit 2 – LOAD** NVM Page Buffer Active Loading

This bit indicates that the NVM page buffer has been loaded with one or more words. Immediately after an NVM load has been performed, this flag is set, and it remains set until a Write Page (WP), Write Quad Word (WQW) or a page buffer clear (PBCLR) command is given.

**Bit 1 – PRM** Power Reduction Mode

This bit indicates the current NVM power reduction state. The NVM block can be set in power reduction mode in two ways: through the command interface or automatically when entering sleep with CTRLA.PRM set accordingly. PRM can be cleared in three ways: through AHB access to the NVM block, through the command interface (SPRM and CPRM) or when exiting sleep with CTRLA.PRM set accordingly.

0: NVM is not in power reduction mode  
 1: NVM is in power reduction mode.

# SAM D5x/E5x Family Data Sheet

## NVMCTRL – Nonvolatile Memory Controller

---

**Bit 0 – READY** Ready to accept a command

0: The NVM controller is busy programming or erasing.

1: The NVM controller is ready to accept a new command.

# SAM D5x/E5x Family Data Sheet

## NVMCTRL – Nonvolatile Memory Controller

### 25.8.8 Address

**Name:** ADDR  
**Offset:** 0x14  
**Reset:** 0x00000000  
**Property:** PAC Write-Protection

Bit	31	30	29	28	27	26	25	24
Access								
Reset								
Bit	23	22	21	20	19	18	17	16
	ADDR[23:16]							
Access	R/W	R/W	R/W	R/W	R/W	R/W	R/W	R/W
Reset	0	0	0	0	0	0	0	0
Bit	15	14	13	12	11	10	9	8
	ADDR[15:8]							
Access	R/W	R/W	R/W	R/W	R/W	R/W	R/W	R/W
Reset	0	0	0	0	0	0	0	0
Bit	7	6	5	4	3	2	1	0
	ADDR[7:0]							
Access	R/W	R/W	R/W	R/W	R/W	R/W	R/W	R/W
Reset	0	0	0	0	0	0	0	0

**Bits 23:0 – ADDR[23:0] NVM Address**

ADDR drives the hardware address to the NVM when a command is executed using CMDEX. It is a Byte address. This register is also automatically updated when writing to the page buffer or when writing the SmartEEPROM.

# SAM D5x/E5x Family Data Sheet

## NVMCTRL – Nonvolatile Memory Controller

### 25.8.9 Lock Section

**Name:** RUNLOCK  
**Offset:** 0x18  
**Reset:** 0xFFFFFFFF  
**Property:** -

	31	30	29	28	27	26	25	24
	RUNLOCK[31:24]							
Access	R	R	R	R	R	R	R	R
Reset	x	x	x	x	x	x	x	x
	23	22	21	20	19	18	17	16
	RUNLOCK[23:16]							
Access	R	R	R	R	R	R	R	R
Reset	x	x	x	x	x	x	x	x
	15	14	13	12	11	10	9	8
	RUNLOCK[15:8]							
Access	R	R	R	R	R	R	R	R
Reset	x	x	x	x	x	x	x	x
	7	6	5	4	3	2	1	0
	RUNLOCK[7:0]							
Access	R	R	R	R	R	R	R	R
Reset	x	x	x	x	x	x	x	x

**Bits 31:0 – RUNLOCK[31:0] Region Un-Lock Bits**

In order to set or clear these bits, the CMD register must be used.

0: The corresponding region is locked.

1: The corresponding region is not locked.

# SAM D5x/E5x Family Data Sheet

## NVMCTRL – Nonvolatile Memory Controller

### 25.8.10 Page Buffer Load Data x

**Name:** PBLDATAn  
**Offset:** 0x1C + n\*0x04 [n=0..1]  
**Reset:** 0xFFFFFFFF  
**Property:** -

	Bit	31	30	29	28	27	26	25	24
		DATA[31:24]							
Access		R	R	R	R	R	R	R	R
Reset		0	0	0	0	0	0	0	0
	Bit	23	22	21	20	19	18	17	16
		DATA[23:16]							
Access		R	R	R	R	R	R	R	R
Reset		0	0	0	0	0	0	0	0
	Bit	15	14	13	12	11	10	9	8
		DATA[15:8]							
Access		R	R	R	R	R	R	R	R
Reset		0	0	0	0	0	0	0	0
	Bit	7	6	5	4	3	2	1	0
		DATA[7:0]							
Access		R	R	R	R	R	R	R	R
Reset		0	0	0	0	0	0	0	1

**Bits 31:0 – DATA[31:0] Page Buffer Data**

# SAM D5x/E5x Family Data Sheet

## NVMCTRL – Nonvolatile Memory Controller

### 25.8.11 ECC Error Status

**Name:** ECCERR  
**Offset:** 0x24  
**Reset:** 0x00000000  
**Property:** -

This register tracks errors on the NVM read path.

ECC error tracking is active until an error is detected. It is still active in case of single error but no dual error. In this case only a dual error can override this register status as a dual error is more critical than a single error. Error tracking resumes as soon as this register is read.

Bit	31	30	29	28	27	26	25	24
	TYPEH[1:0]		TYPEL[1:0]					
Access	R	R	R	R				
Reset	0	0	0	0				
Bit	23	22	21	20	19	18	17	16
	ADDR[23:16]							
Access	R	R	R	R	R	R	R	R
Reset	0	0	0	0	0	0	0	0
Bit	15	14	13	12	11	10	9	8
	ADDR[15:8]							
Access	R	R	R	R	R	R	R	R
Reset	0	0	0	0	0	0	0	0
Bit	7	6	5	4	3	2	1	0
	ADDR[7:0]							
Access	R	R	R	R	R	R	R	R
Reset	0	0	0	0	0	0	0	0

**Bits 31:30 – TYPEH[1:0]** High Double-Word Error Type

Indicates the type of error detected on the NVM 64-bit most significant read word. It is reset to None when this register is read except if an error occurs in the same cycle.

Value	Name	Description
0x0	None	No Error Detected Since Last Read
0x1	Single	At Least One Single Error Detected Since last Read
0x2	Dual	At Least One Dual Error Detected Since Last Read
0x3		Reserved

**Bits 29:28 – TYPEL[1:0]** Low Double-Word Error Type

Indicates the type of error detected on the NVM 64-bit less significant read word. It is reset to None when this register is read except if an error occurs in the same cycle.

Value	Name	Description
0x0	None	No Error Detected Since Last Read
0x1	Single	At Least One Single Error Detected Since last Read
0x2	Dual	At Least One Dual Error Detected Since Last Read
0x3		Reserved



# SAM D5x/E5x Family Data Sheet

## NVMCTRL – Nonvolatile Memory Controller

---

---

**Bits 23:0 – ADDR[23:0]** Error Address

Indicates the Byte address of the last detected error.

# SAM D5x/E5x Family Data Sheet

## NVMCTRL – Nonvolatile Memory Controller

### 25.8.12 Debug Control

**Name:** DBGCTRL  
**Offset:** 0x28  
**Reset:** 0x00  
**Property:** PAC Write-Protection

Bit	7	6	5	4	3	2	1	0
							ECCELOG	ECCDIS
Access							R/W	R/W
Reset							0	0

**Bit 1 – ECCELOG** Debugger ECC Error Tracking Mode

0: ECC errors detected during a read initiated by a debugger are not logged.

1: ECC errors detected during a read initiated by a debugger are logged.

**Bit 0 – ECCDIS** Debugger ECC Read Disable

Value	Description
0	ECC errors for debugger reads are corrected and logged in INTFLAG
1	ECC errors for debugger reads are not corrected or logged in INTFLAG

# SAM D5x/E5x Family Data Sheet

## NVMCTRL – Nonvolatile Memory Controller

### 25.8.13 SmartEEPROM Configuration

**Name:** SEECFG  
**Offset:** 0x2A  
**Reset:** 0x00  
**Property:** PAC Write-Protection

	Bit	7	6	5	4	3	2	1	0
								APRDIS	WMODE
Access								R/W	R/W
Reset								0	0

**Bit 1 – APRDIS** Automatic Page Reallocation Disable

0: enables the Automatic page Reallocation.

1: disables the Automatic page Reallocation.

**Bit 0 – WMODE** Write Mode

Indicates the type of bufferization used.

Value	Name	Description
0x0	UNBUFFERED	A NVM write command is issued after each write in the pagebuffer
0x1	BUFFERED	A NVM write command is issued when a write to a new page is requested

# SAM D5x/E5x Family Data Sheet

## NVMCTRL – Nonvolatile Memory Controller

### 25.8.14 SmartEEPROM Status

**Name:** SEESTAT  
**Offset:** 0x2C  
**Reset:** 0x00000000  
**Property:** Read-Only

	Bit	31	30	29	28	27	26	25	24	
Access										
Reset										
	Bit	23	22	21	20	19	18	17	16	
							PSZ[2:0]			
Access							R	R	R	
Reset							0	0	x	
	Bit	15	14	13	12	11	10	9	8	
						SBLK[3:0]				
Access						R	R	R	R	
Reset						0	0	0	x	
	Bit	7	6	5	4	3	2	1	0	
					RLOCK	LOCK	BUSY	LOAD	ASEES	
Access					R	R	R	R	R	
Reset					0	x	0	0	x	

**Bits 18:16 – PSZ[2:0]** SmartEEPROM Page Size

This bit field is automatically loaded from the user page during startup. Indicates the page size. Not all device families will provide all the page sizes indicated in the table.

**Bits 11:8 – SBLK[3:0]** Blocks Number In a Sector

This bit field is automatically loaded from the user page during startup. Indicates the number of blocks allocated to a SEES.

**Bit 4 – RLOCK** RLOCK

SmartEEPROM Write Access To Register Address Space Is Locked

**Bit 3 – LOCK** SmartEEPROM Section Locked

This bit field is automatically loaded from the user page during startup. Access to the SmartEEPROM data is locked. Writes to AHB2 throws hardfault exceptions.

- 0: SmartEEPROM access is not locked
- 1: SmartEEPROM access is locked

**Bit 2 – BUSY** Busy

- 0: SmartEEPROM is ready.
- 1: SmartEEPROM is busy processing a read or a write operation.

# SAM D5x/E5x Family Data Sheet

## NVMCTRL – Nonvolatile Memory Controller

---

### **Bit 1 – LOAD** Page Buffer Loaded

0: SmartEEPROM has not left unwritten data in the page buffer.

1: SmartEEPROM has left unwritten data in the page buffer.

### **Bit 0 – ASEES** Active SmartEEPROM Sector

This bit field is automatically loaded during startup from a special fuse in the NVM.

Indicates the active SEES

0: SEES0 is active

1: SEES1 is active

## **26. ICM - Integrity Check Monitor**

### **26.1 Overview**

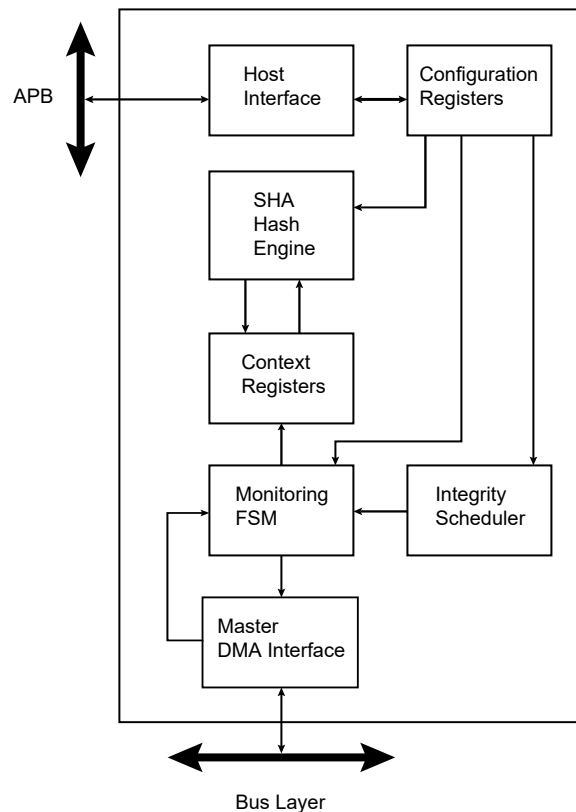
The Integrity Check Monitor (ICM) is a DMA controller that performs hash calculation over multiple memory regions through the use of transfer descriptors located in memory (ICM Descriptor Area). The Hash function is based on the Secure Hash Algorithm (SHA). The ICM controller integrates two modes of operation. The first one is used to hash a list of memory regions and save the digests to memory (ICM Hash Area). The second operation mode is an active monitoring of the memory. In that mode, the hash function is evaluated and compared to the digest located at a predefined memory address (ICM Hash Area). If a mismatch occurs, an interrupt is raised.

### **26.2 Features**

- DMA AHB master interface
- Supports monitoring of up to four non-contiguous memory regions
- Supports block gathering through the use of linked list
- Supports Secure Hash Algorithm (SHA1, SHA224, SHA256)
- Compliant with FIPS Publication 180-2
- Configurable processing period:
  - When SHA1 algorithm is processed, the run-time period is either 85 or 209 clock cycles.
  - When SHA256 or SHA224 algorithm is processed, the run-time period is either 72 or 194 clock cycles.
- Programmable bus burden

### 26.3 Block Diagram

Figure 26-1. Integrity Check Monitor Block Diagram



### 26.4 Signal Description

Not applicable.

### 26.5 Product Dependencies

In order to use this peripheral, other parts of the system must be configured correctly, as described below.

#### 26.5.1 Power Management

The ICM will run only when the source clocks are running, i.e. when the CPU is in Active mode.

#### 26.5.2 Clocks

The ICM bus clocks (CLK\_ICM\_AHB and CLK\_ICM\_APB) can be enabled and disabled in the Main Clock module (MCLK) by writing the respective bit in the mask registers (MCLK.AHBMASK.ICM and MCLK.APBCMASK.ICM).

The default states of CLK\_ICM\_AHB and CLK\_ICM\_APB are given by the reset values of the respective mask registers.

#### Related Links

[15.7 Register Summary](#)

### 26.5.3 DMA

Not applicable.

### 26.5.4 Interrupts

The ICM has an interrupt line connected to the Interrupt Controller. Handling the ICM interrupt requires programming the interrupt controller before configuring the ICM.

#### Related Links

[10.2 Nested Vector Interrupt Controller](#)

### 26.5.5 Events

Not applicable.

### 26.5.6 Debug Operation

Not applicable.

## 26.6 Functional Description

### 26.6.1 Overview

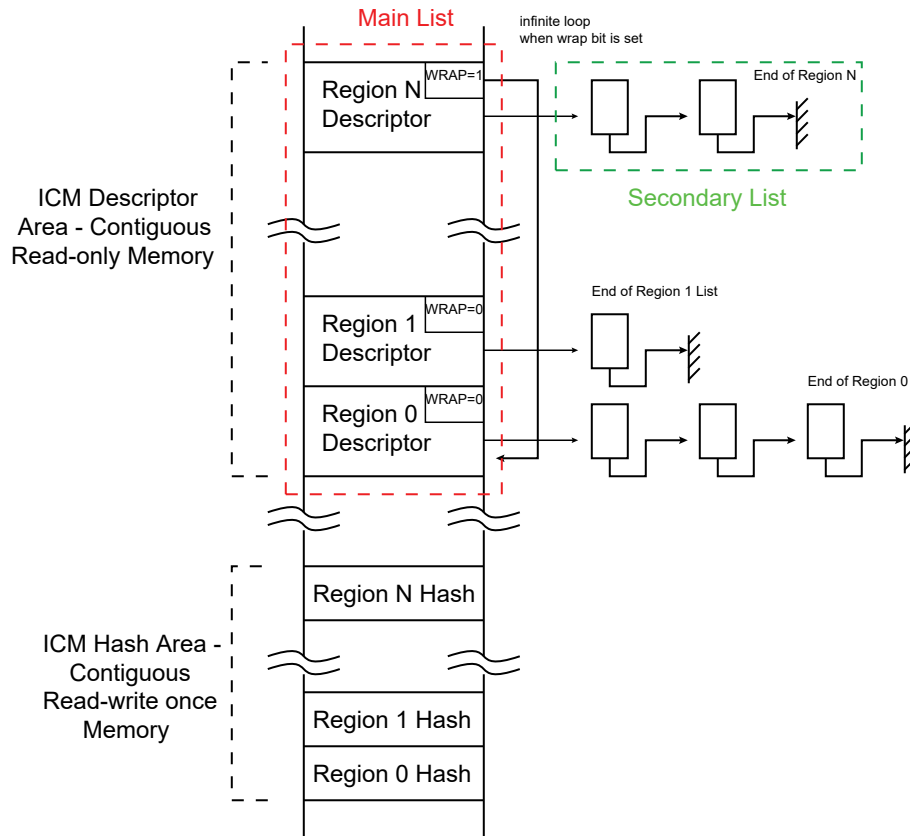
The Integrity Check Monitor (ICM) is a DMA controller that performs SHA-based memory hashing over memory regions. As shown in [the Block Diagram](#), it integrates a DMA interface, a Monitoring Finite State Machine (FSM), an integrity scheduler, a set of context registers, a SHA engine, an interface for configuration and status registers.

The SHA engine requires a message padded according to FIPS180-4 specification when used as a SHA calculation unit only. Otherwise, if the ICM is used as integrated check for memory content, the padding is not mandatory. The SHA module produces an N-bit message digest each time a block is read and a processing period ends. N is 160 for SHA1, 224 for SHA224, 256 for SHA256.

When the ICM module is enabled, it sequentially retrieves a circular list of region descriptors from the memory (Main List described in [Figure 26-2](#)). Up to four regions may be monitored. Each region descriptor is composed of four words indicating the layout of the memory region (see also Example in [26.6.3 Region Descriptor Structure](#)). It also contains the hashing engine configuration on a per region basis. As soon as the descriptor is loaded from the memory and context registers are updated with the data structure, the hashing operation starts. A programmable number of blocks (see TRSIZE field of the RCTRL structure member) is transferred from the memory to the SHA engine. When the desired number of blocks have been transferred, the digest is either moved to memory (Write Back function) or compared with a digest reference located in the system memory (Compare function). If a digest mismatch occurs, an interrupt is triggered if unmasked. The ICM module passes through the region descriptor list until the end of the list marked by an End of List bit set to one. To continuously monitor the list of regions, the WRAP bit must be set to one in the last data structure.

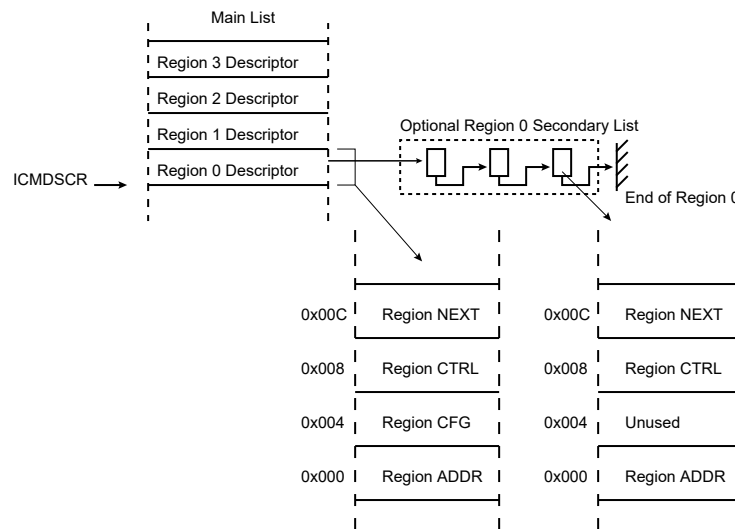


**Figure 26-2. ICM Region Descriptor and Hash Areas**



Each region descriptor supports gathering of data through the use of the Secondary List. Unlike the Main List, the Secondary List cannot modify the configuration attributes of the region. When the end of the Secondary List has been encountered, the ICM returns to the Main List. Memory integrity monitoring can be considered as a background service and the mandatory bandwidth shall be very limited. In order to limit the ICM memory bandwidth, use the [BBC](#) field of the [CFG](#) register to control ICM memory load.

**Figure 26-3. Region Descriptor**



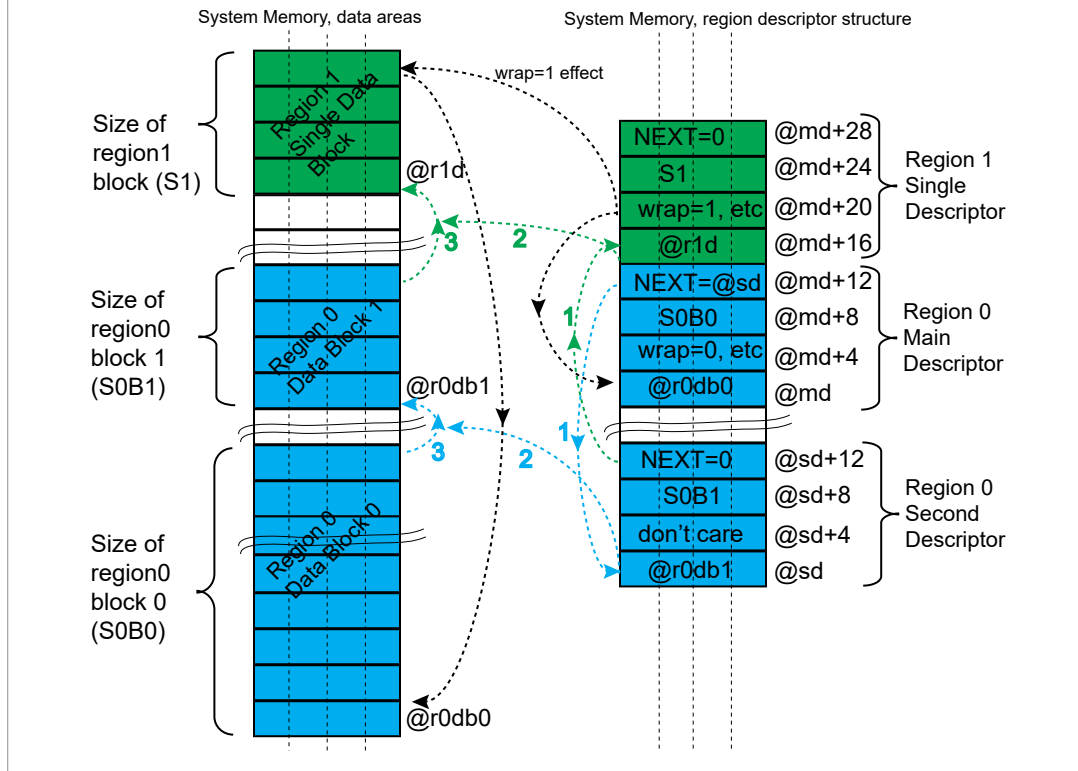




### Example 26-1. ICM Monitoring of 3 Memory Data Blocks (Defined as 2 Regions)

The following figure shows the mandatory ICM settings to monitor three memory data blocks of the system memory (defined as two regions) with one region being not contiguous (two separate areas) and one contiguous memory area. For each said region, the SHA algorithm may be independently selected (different for each region). The wrap allows continuous monitoring.

**Figure 26-4. Example - Monitoring of 3 Memory Data Blocks (Defined as 2 Regions)**



# SAM D5x/E5x Family Data Sheet

## ICM - Integrity Check Monitor

### 26.6.3.1 Region Descriptor Structure Overview

Offset	Name	Bit Pos.									
0x00	RADDR0	7:0	RADDR[7:0]								
		15:8	RADDR[15:8]								
		23:16	RADDR[23:16]								
		31:24	RADDR[31:24]								
0x04	RCFG0	7:0	WCIEEN	BEIEEN	DMIEEN	RHIEEN		EOM	WRAP	CDWBN	
		15:8	ALGO[2:0]				PROCDLY	SUIEEN	ECIEEN		
		23:16									
		31:24									
0x08	RCTRL0	7:0	TRSIZE[7:0]								
		15:8	TRSIZE[15:8]								
		23:16									
		31:24									
0x0C	RADDR1	7:0	RADDR[7:0]								
		15:8	RADDR[15:8]								
		23:16	RADDR[23:16]								
		31:24	RADDR[31:24]								
0x0C	RNEXT0	7:0									
		15:8									
		23:16									
		31:24									
0x10	RCFG1	7:0	WCIEEN	BEIEEN	DMIEEN	RHIEEN		EOM	WRAP	CDWBN	
		15:8	ALGO[2:0]				PROCDLY	SUIEEN	ECIEEN		
		23:16									
		31:24									
0x14	RCTRL1	7:0	TRSIZE[7:0]								
		15:8	TRSIZE[15:8]								
		23:16									
		31:24									
0x18	RADDR2	7:0	RADDR[7:0]								
		15:8	RADDR[15:8]								
		23:16	RADDR[23:16]								
		31:24	RADDR[31:24]								
0x18	RNEXT1	7:0									
		15:8									
		23:16									
		31:24									
0x1C	RCFG2	7:0	WCIEEN	BEIEEN	DMIEEN	RHIEEN		EOM	WRAP	CDWBN	
		15:8	ALGO[2:0]				PROCDLY	SUIEEN	ECIEEN		
		23:16									
		31:24									
0x20	RCTRL2	7:0	TRSIZE[7:0]								
		15:8	TRSIZE[15:8]								
		23:16									
		31:24									

# SAM D5x/E5x Family Data Sheet

## ICM - Integrity Check Monitor

.....continued

Offset	Name	Bit Pos.									
0x24	RADDR3	7:0	RADDR[7:0]								
		15:8	RADDR[15:8]								
		23:16	RADDR[23:16]								
		31:24	RADDR[31:24]								
0x24	RNEXT2	7:0									
		15:8									
		23:16									
		31:24									
0x28	RCFG3	7:0	WCIE	BEIE	DME	RHE		EOM	WRAP	CDWBN	
		15:8		ALGO[2:0]				PROCDLY	SUIE	ECIE	
		23:16									
		31:24									
0x2C	RCTRL3	7:0	TRSIZE[7:0]								
		15:8	TRSIZE[15:8]								
		23:16									
		31:24									
0x30	RNEXT3	7:0									
		15:8									
		23:16									
		31:24									

# SAM D5x/E5x Family Data Sheet

## ICM - Integrity Check Monitor

### 26.6.3.1.1 Region Start Address Structure Member

**Name:** RADDR  
**Offset:** 0x00 + n\*0x0C [n=0..3]  
**Reset:** 0x00000000  
**Property:** Read/Write

	Bit	31	30	29	28	27	26	25	24
		RADDR[31:24]							
Access		R/W	R/W	R/W	R/W	R/W	R/W	R/W	R/W
Reset		0	0	0	0	0	0	0	0
	Bit	23	22	21	20	19	18	17	16
		RADDR[23:16]							
Access		R/W	R/W	R/W	R/W	R/W	R/W	R/W	R/W
Reset		0	0	0	0	0	0	0	0
	Bit	15	14	13	12	11	10	9	8
		RADDR[15:8]							
Access		R/W	R/W	R/W	R/W	R/W	R/W	R/W	R/W
Reset		0	0	0	0	0	0	0	0
	Bit	7	6	5	4	3	2	1	0
		RADDR[7:0]							
Access		R/W	R/W	R/W	R/W	R/W	R/W	R/W	R/W
Reset		0	0	0	0	0	0	0	0

**Bits 31:0 – RADDR[31:0]** Region Start Address  
 This field indicates the first byte address of the region

# SAM D5x/E5x Family Data Sheet

## ICM - Integrity Check Monitor

### 26.6.3.1.2 Region Configuration Structure Member

**Name:** RCFG  
**Offset:** 0x04 + n\*0x0C [n=0..3]  
**Reset:** 0x00000000  
**Property:** Read/Write

Bit	31	30	29	28	27	26	25	24
	[Greyed out register bits]							
Access								
Reset								
Bit	23	22	21	20	19	18	17	16
	[Greyed out register bits]							
Access								
Reset								
Bit	15	14	13	12	11	10	9	8
		ALGO[2:0]				PROCDLY	SUIEN	ECIEN
Access						R/W	R/W	R/W
Reset		0	0	0		0	1	1
Bit	7	6	5	4	3	2	1	0
	WCIEN	BEIEN	DMIEN	RHIEN		EOM	WRAP	CDWBN
Access	R/W	R/W	R/W	R/W		R/W	R/W	R/W
Reset	1	1	1	1		0	0	0

#### Bits 14:12 – ALGO[2:0] User SHA Algorithm

Value	Name	Description
0	SHA1	SHA1 algorithm processed
1	SHA256	SHA256 algorithm processed
4	SHA224	SHA224 algorithm processed
Other	-	Reserved

#### Bit 10 – PROCDLY Processing Delay

For a given SHA algorithm, the runtime period has two possible lengths:

**Table 26-2. SHA Processing Runtime Periods**

Algorithm	SHORTEST [number of cycles]	LONGEST [number of cycles]
SHA1	85	209
SHA224	72	194
SHA256	72	194

Value	Name	Description
0	SHORTEST	SHA processing runtime is the shortest one
1	LONGEST	SHA processing runtime is the longest one



**Bit 9 – SUIEN** Monitoring Status Updated Condition Interrupt Enable

0: The RSU flag is set when the corresponding descriptor is loaded from memory to ICM.

1: The RSU flag remains cleared even if the condition is met.

**Bit 8 – ECIEN** End Bit Condition Interrupt Enable

0: The REC flag is set when the descriptor having the EOM bit set is processed.

1: The REC flag remains cleared even if the setting condition is met.

**Bit 7 – WCIEN** Wrap Condition Interrupt Disable

0: The RWC flag is set when the WRAP

1: The RWC flag remains cleared even if the setting condition is met.

**Bit 6 – BEIEN** Bus Error Interrupt Disable

0: The flag is set when an error is reported on the system bus by the bus MATRIX.

1: The flag remains cleared even if the setting condition is met.

**Bit 5 – DMIEN** Digest Mismatch Interrupt Disable

0: The RBE flag is set when the hash value just calculated from the processed region differs from expected hash value.

1: The RBE flag remains cleared even if the setting condition is met.

**Bit 4 – RHIEEN** Region Hash Completed Interrupt Disable

0: The RHC flag is set when the field NEXT = 0 in a descriptor of the main or second list.

1: The RHC flag remains cleared even if the setting condition is met.

**Bit 2 – EOM** End of Monitoring

0: The current descriptor does not terminate the monitoring.

1: The current descriptor terminates the Main List. WRAP bit value has no effect.

**Bit 1 – WRAP** Wrap Command

0: The next region descriptor address loaded is the current region identifier descriptor address incremented by 0x10.

1: The next region descriptor address loaded is DSCR.

**Bit 0 – CDWBN** Compare Digest or Write Back Digest

0: The digest is written to the Hash area.

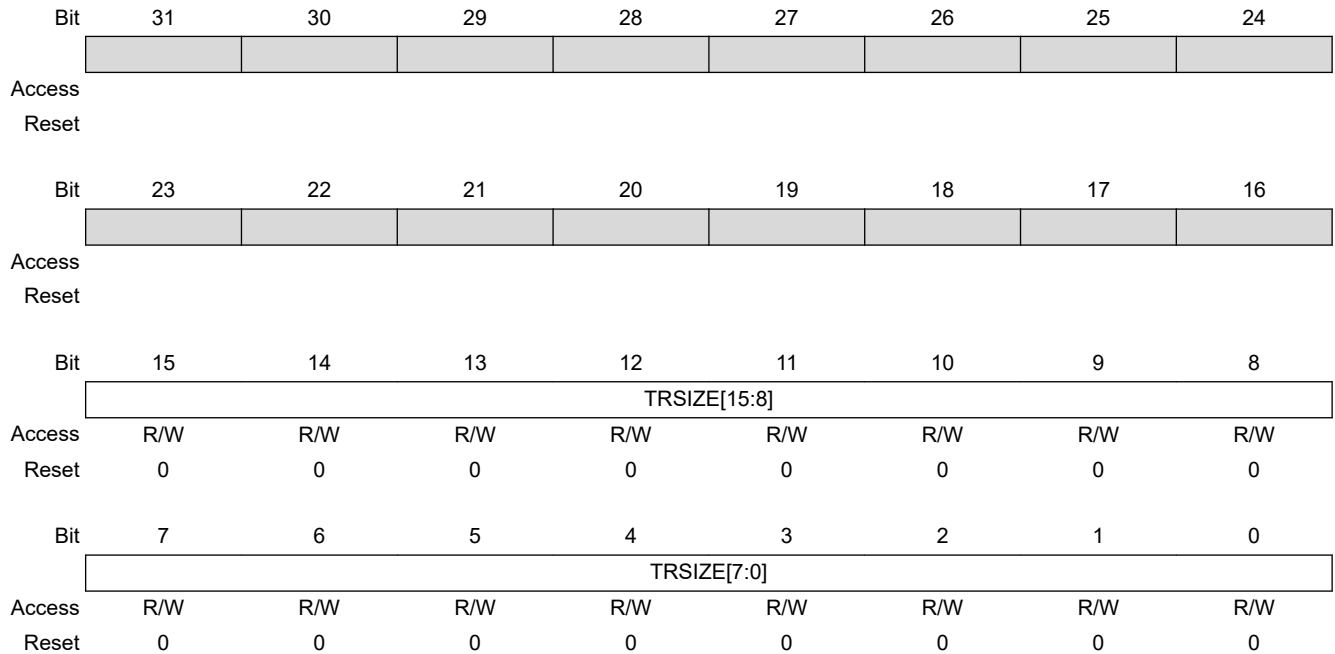
1: The digest value is compared to the digest stored in the Hash area.

# SAM D5x/E5x Family Data Sheet

## ICM - Integrity Check Monitor

### 26.6.3.1.3 Region Control Structure Member

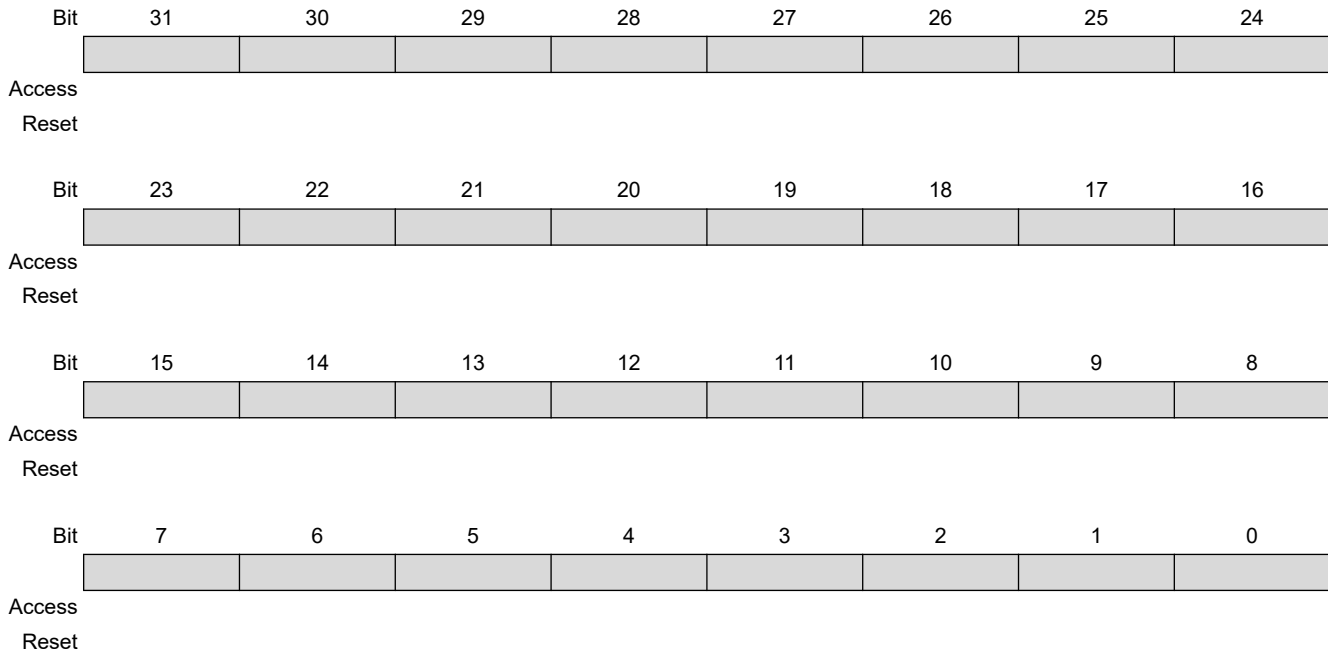
**Name:** RCTRL  
**Offset:** 0x08 + n\*0x0C [n=0..3]  
**Reset:** 0x00000000  
**Property:** R/W



**Bits 15:0 – TRSIZE[15:0]** Transfer Size for the Current Chunk of Data

### 26.6.3.1.4 Region Next Address Structure Member

**Name:** RNEXT  
**Offset:** 0x0C + n\*0x0C [n=0..3]  
**Reset:** 0x00000000  
**Property:** Read/Write



### 26.6.4 Using ICM as an SHA Engine

The ICM can be configured to only calculate a SHA1, SHA224, SHA256 digest value.

#### 26.6.4.1 Settings for Simple SHA Calculation

The start address of the system memory containing the data to hash must be configured in the transfer descriptor of the DMA embedded in the ICM.

The transfer descriptor is a system memory area integer multiple of 4 x 32-bit word and the start address of the descriptor must be configured in **DSCR** (the start address must be aligned on 64-bytes; six LSB must be cleared). If the data to hash is already padded according to SHA standards, only a single descriptor is required, and the EOM bit of **RCFGn** must be written to 1. If the data to hash does not contain a padding area, it is possible to define the padding area in another system memory location, the ICM can be configured to automatically jump from a memory area to another one by writing the descriptor register **RNEXT** with a value that differs from 0. Writing the **RNEXT** register with the start address of the padding area forces the ICM to concatenate both areas, thus providing the SHA result from the start address of the hash area configured in **HASH**.

Whether the system memory is configured as a single or multiple data block area, the bits **CDWBN** and **WRAP** must be cleared in the region descriptor structure member **RCFGn**. The bits **WBDIS**, **EOMDIS**, **SLBDIS** must be cleared in **CFG**.

Write the bits **RHIEN** and **ECIEN** in the Region Configuration Structure Member (**RCFGn**) to '0':

- The flag **RHC[i]**, *i* being the region index, is set (if **RHIEN** is '0') when the hash result is available at address defined in **HASH**.

- The flag REC[i], i being the region index, is set (if ECIEEN is '0') when the hash result is available at the address defined in HASH.

An interrupt is generated if the bit RHC[i] is written to '1' in the IER (if RHC[i] is set in RCTRL of region i) or if the bit REC[i] is written to 1 in the IER (if REC[i] is set in RCTRL of region i).

### 26.6.4.2 Processing Period

The SHA engine processing period can be configured by writing to the Region Configuration Structure Member register (RCFGn).

The short processing period allows to allocate bandwidth to the SHA module whereas the long processing period allocates more bandwidth on the system bus to other applications.

In SHA mode, the shortest processing period is 85 clock cycles + 2 clock cycles for start command synchronization. The longest period is 209 clock cycles + 2 clock cycles.

In SHA256 and SHA224 modes, the shortest processing period is 72 clock cycles + 2 clock cycles for start command synchronization. The longest period is 194 clock cycles + 2 clock cycles.

### 26.6.5 ICM Automatic Monitoring Mode

The ASCD bit of the CFG register is used to activate the ICM Automatic Mode. When CFG.ASCD is set, the ICM performs the following actions:

- The ICM controller passes through the Main List once with CDWBN bit in RCFGn at 0 (i.e., Write Back activated) and EOM bit in the RCFGn context register at 0.
- When RCFGn.WRAP=1, the ICM controller enters active monitoring, with CDWBN bit in context register now set, and EOM bit in context register cleared. Writing to the CDWBN and EOM bits in RCFGn has no effect.

# SAM D5x/E5x Family Data Sheet

## ICM - Integrity Check Monitor

### 26.6.6 ICM Configuration Parameters

Transfer Type		Main List	RCFG			RNEXT	Comments
			CDWBN	WRAP	EOM	NEXT	
Single Region	Contiguous list of blocks Digest written to memory Monitoring disabled	1 item	0	0	1	0	The Main List contains only one descriptor. The Secondary List is empty for that descriptor. The digest is computed and saved to memory.
	Non-contiguous list of blocks Digest written to memory Monitoring disabled	1 item	0	0	1	Secondary List address of the current region identifier	The Main List contains only one descriptor. The Secondary List describes the layout of the non-contiguous region.
	Contiguous list of blocks Digest comparison enabled Monitoring enabled	1 item	1	1	0	0	When the hash computation is terminated, the digest is compared with the one saved in memory.

# SAM D5x/E5x Family Data Sheet

## ICM - Integrity Check Monitor

.....continued

Transfer Type		Main List	RCFG			RNEXT	Comments
			CDWBN	WRAP	EOM	NEXT	
Multiple Regions	Contiguous list of blocks Digest written to memory Monitoring disabled	More than one item	0	0	1 for the last, 0 otherwise	0	ICM passes through the list once.
	Contiguous list of blocks  Digest comparison is enabled  Monitoring is enabled	More than one item	1	1 for the last, 0 otherwise	0	0	ICM performs active monitoring of the regions. If a mismatch occurs, an interrupt is raised.
	Non-contiguous list of blocks Digest is written to memory Monitoring is disabled	More than one item	0	0	1	Secondary List address	ICM performs hashing and saves digests to the Hash area.
	Non-contiguous list of blocks Digest comparison is enabled  Monitoring is enabled	More than one item	1	1	0	Secondary List address	ICM performs data gathering on a per region basis.

### 26.6.7 Security Features

When an undefined register access occurs, the URAD bit in the Interrupt Status Register (**ISR**) is set if unmasked. Its source is then reported in the Undefined Access Status Register (**UASR**). Only the first undefined register access is available through the **UASR.URAT** field.

Several kinds of unspecified register accesses can occur:

- Unspecified structure member set to one detected when the descriptor is loaded
- Configuration register (**CFG**) modified during active monitoring
- Descriptor register (**DSCR**) modified during active monitoring
- Hash register (**HASH**) modified during active monitoring
- Write-only register read access

The URAD bit and the URAT field can only be reset by writing a 1 to the **CTRL.SWRST** bit.

# SAM D5x/E5x Family Data Sheet

## ICM - Integrity Check Monitor

### 26.7 Register Summary - ICM

Offset	Name	Bit Pos.							
0x00	CFG	7:0	BBC[3:0]				SLBDIS	EOMDIS	WBDIS
		15:8	UALGO[2:0]		UIHASH			DUALBUFF	ASCD
		23:16							
		31:24							
0x04	CTRL	7:0	REHASH[3:0]				SWRST	DISABLE	ENABLE
		15:8	RMEN[3:0]			RMDIS[3:0]			
		23:16							
		31:24							
0x08	SR	7:0						ENABLE	
		15:8	RMDIS[3:0]			RAWRMDIS[3:0]			
		23:16							
		31:24							
0x0C ... 0x0F	Reserved								
0x10	IER	7:0	RDM[3:0]			RHC[3:0]			
		15:8	RWC[3:0]			RBE[3:0]			
		23:16	RSU[3:0]			REC[3:0]			
		31:24							URAD
0x14	IDR	7:0	RDM[3:0]			RHC[3:0]			
		15:8	RWC[3:0]			RBE[3:0]			
		23:16	RSU[3:0]			REC[3:0]			
		31:24							URAD
0x18	IMR	7:0	RDM[3:0]			RHC[3:0]			
		15:8	RWC[3:0]			RBE[3:0]			
		23:16	RSU[3:0]			REC[3:0]			
		31:24							URAD
0x1C	ISR	7:0	RDM[3:0]			RHC[3:0]			
		15:8	RWC[3:0]			RBE[3:0]			
		23:16	RSU[3:0]			REC[3:0]			
		31:24							URAD
0x20	UASR	7:0				URAT[2:0]			
		15:8							
		23:16							
		31:24							
0x24 ... 0x2F	Reserved								
0x30	DSCR	7:0	DASA[1:0]						
		15:8	DASA[9:2]						
		23:16	DASA[17:10]						
		31:24	DASA[25:18]						

# SAM D5x/E5x Family Data Sheet

## ICM - Integrity Check Monitor

.....continued

Offset	Name	Bit Pos.							
0x34	HASH	7:0	HASA[0:0]						
		15:8					HASA[8:1]		
		23:16					HASA[16:9]		
		31:24					HASA[24:17]		
0x38	UIHVALx0	7:0					VAL[7:0]		
		15:8					VAL[15:8]		
		23:16					VAL[23:16]		
		31:24					VAL[31:24]		
0x3C	UIHVALx1	7:0					VAL[7:0]		
		15:8					VAL[15:8]		
		23:16					VAL[23:16]		
		31:24					VAL[31:24]		
0x40	UIHVALx2	7:0					VAL[7:0]		
		15:8					VAL[15:8]		
		23:16					VAL[23:16]		
		31:24					VAL[31:24]		
0x44	UIHVALx3	7:0					VAL[7:0]		
		15:8					VAL[15:8]		
		23:16					VAL[23:16]		
		31:24					VAL[31:24]		
0x48	UIHVALx4	7:0					VAL[7:0]		
		15:8					VAL[15:8]		
		23:16					VAL[23:16]		
		31:24					VAL[31:24]		
0x4C	UIHVALx5	7:0					VAL[7:0]		
		15:8					VAL[15:8]		
		23:16					VAL[23:16]		
		31:24					VAL[31:24]		
0x50	UIHVALx6	7:0					VAL[7:0]		
		15:8					VAL[15:8]		
		23:16					VAL[23:16]		
		31:24					VAL[31:24]		
0x54	UIHVALx7	7:0					VAL[7:0]		
		15:8					VAL[15:8]		
		23:16					VAL[23:16]		
		31:24					VAL[31:24]		

## 26.8 Register Description

Registers can be 8, 16, or 32 bits wide. Atomic 8-, 16- and 32-bit accesses are supported. In addition, the 8-bit quarters and 16-bit halves of a 32-bit register, and the 8-bit halves of a 16-bit register can be accessed directly.

Some registers are optionally write-protected by the Peripheral Access Controller (PAC). Optional PAC write protection is denoted by the "PAC Write-Protection" property in each individual register description. For details, refer to [22.5.8 Register Access Protection](#).



# SAM D5x/E5x Family Data Sheet

## ICM - Integrity Check Monitor

---

Some registers are enable-protected, meaning they can only be written when the peripheral is disabled. Enable-protection is denoted by the "Enable-Protected" property in each individual register description.

### Related Links

[26.6.3 Region Descriptor Structure](#)

# SAM D5x/E5x Family Data Sheet

## ICM - Integrity Check Monitor

### 26.8.1 Configuration Register

**Name:** CFG  
**Offset:** 0x00  
**Reset:** 0x0  
**Property:** -

Bit	31	30	29	28	27	26	25	24
Access								
Reset								
Bit	23	22	21	20	19	18	17	16
Access								
Reset								
Bit	15	14	13	12	11	10	9	8
	UALGO[2:0]			UIHASH			DUALBUFF	ASCD
Access								R/W
Reset	0	0	0	0			0	0
Bit	7	6	5	4	3	2	1	0
	BBC[3:0]					SLBDIS	EOMDIS	WBDIS
Access	R/W	R/W	R/W	R/W		R/W	R/W	R/W
Reset	0	0	0	0		0	0	0

#### Bits 15:13 – UALGO[2:0] User SHA Algorithm

Value	Name	Description
0	SHA1	SHA1 algorithm processed
1	SHA256	SHA256 algorithm processed
4	SHA224	SHA224 algorithm processed
Other	-	Reserved

#### Bit 12 – UIHASH User Initial Hash Value

Value	Description
0	The secure hash standard provides the initial hash value.
1	The initial hash value is programmable. Field UALGO provides the SHA algorithm. The ALGO field of the <a href="#">RCFGn</a> structure member has no effect.

#### Bit 9 – DUALBUFF Dual Input Buffer

Value	Description
0	Dual Input buffer mode is disabled.
1	Dual Input buffer mode is enabled (Better performances, higher bandwidth required on system bus).

#### Bit 8 – ASCD Automatic Switch To Compare Digest

# SAM D5x/E5x Family Data Sheet

## ICM - Integrity Check Monitor

Value	Description
0	Automatic mode is disabled.
1	When this mode is enabled, the ICM controller automatically switches to active monitoring after the first Main List pass. Both CDWBN and WBDIS bits have no effect. A '1' must be written to the End of Monitoring bit in the Region Configuration register (RCFG.EOM) to terminate the monitoring.

### Bits 7:4 – BBC[3:0] Bus Burden Control

This field is used to control the burden of the ICM system bus. The number of system clock cycles between the end of the current processing and the next block transfer is set to  $2^{\text{BBC}}$ . Up to 32768 cycles can be inserted.

### Bit 2 – SLBDIS Secondary List Branching Disable

Value	Description
0	Branching to the Secondary List is permitted.
1	Branching to the Secondary List is forbidden. The NEXT field of the RNEXT structure member has no effect and is always considered as zero.

### Bit 1 – EOMDIS End of Monitoring Disable

Value	Description
0	End of Monitoring is permitted.
1	End of Monitoring is forbidden. The EOM bit of the RCFG structure member has no effect.

### Bit 0 – WBDIS Write Back Disable

1:

When the Automatic Switch to Compare Digest bit of this register (CFG.ASCD) is written to '1', this bit value has no effect.

Value	Description
0	Write Back Operations are permitted.
1	Write Back Operations are forbidden: Context register CDWBN bit is internally set to '1' and cannot be modified by a linked list element. The CDWBN bit of the RCFG structure member has no effect.

# SAM D5x/E5x Family Data Sheet

## ICM - Integrity Check Monitor

### 26.8.2 Control Register

**Name:** CTRL  
**Offset:** 0x04  
**Property:** -

Bit	31	30	29	28	27	26	25	24
Access								
Reset								
Bit	23	22	21	20	19	18	17	16
Access								
Reset								
Bit	15	14	13	12	11	10	9	8
	RMEN[3:0]				RMDIS[3:0]			
Access	W	W	W	W	W	W	W	W
Reset								
Bit	7	6	5	4	3	2	1	0
	REHASH[3:0]					SWRST	DISABLE	ENABLE
Access	W	W	W	W		W	W	W
Reset							0	0

#### Bits 15:12 – RMEN[3:0] Region Monitoring Enable

Value	Description
0	No effect.
1	When bit RMEN[i] is written to '1', the monitoring of region with identifier i is activated.

#### Bits 11:8 – RMDIS[3:0] Region Monitoring Disable

Value	Description
0	No effect.
1	When REHASH[i] is written to '1', Region i digest is re-computed. This bit is only available when region monitoring is disabled.

#### Bits 7:4 – REHASH[3:0] Recompute Internal Hash

Value	Description
0	No effect.
1	When REHASH[i] is written to '1', Region i digest is re-computed. This bit is only available when region monitoring is disabled.

#### Bit 2 – SWRST Software Reset

Value	Description
0	No effect.
1	Resets the ICM controller.

#### Bit 1 – DISABLE ECM Disable

# SAM D5x/E5x Family Data Sheet

## ICM - Integrity Check Monitor

---

---

Value	Description
0	No effect.
1	The ICM controller is disabled. If a region is activated, the region is terminated.

### Bit 0 – ENABLE ICM Enable

Value	Description
0	No effect.
1	The ICM controller is activated.

# SAM D5x/E5x Family Data Sheet

## ICM - Integrity Check Monitor

### 26.8.3 Status Register

**Name:** SR  
**Offset:** 0x08  
**Property:** Read-Only

	Bit	31	30	29	28	27	26	25	24	
		[Greyed out register bits 31:24]								
Access										
Reset										
	Bit	23	22	21	20	19	18	17	16	
		[Greyed out register bits 23:16]								
Access										
Reset										
	Bit	15	14	13	12	11	10	9	8	
		RMDIS[3:0]				RAWRMDIS[3:0]				
Access		R	R	R	R	R	R	R	R	
Reset		0	0	0	0	0	0	0	0	
	Bit	7	6	5	4	3	2	1	0	
		[Greyed out register bits 7:1]								ENABLE
Access										R
Reset										0

#### Bits 15:12 – RMDIS[3:0] Region Monitoring Disabled Status

Value	Description
0	Region i is being monitored (occurs after integrity check value has been calculated and written to Hash area).
1	Region i is not being monitored.

#### Bits 11:8 – RAWRMDIS[3:0] Region Monitoring Disabled Raw Status

Value	Description
0	Region i monitoring has been activated by writing a 1 in <a href="#">RMEN[i]</a> of <a href="#">CTRL</a>
1	Region i monitoring has been deactivated by writing a 1 in <a href="#">RMDIS[i]</a> of <a href="#">CTRL</a>

#### Bit 0 – ENABLE ICM Controller Enable Register

Value	Description
0	ICM controller is disabled.
1	ICM controller is activated.

# SAM D5x/E5x Family Data Sheet

## ICM - Integrity Check Monitor

### 26.8.4 Interrupt Enable Register

**Name:** IER  
**Offset:** 0x10  
**Reset:** 0x00000000  
**Property:** Write-Only

Bit	31	30	29	28	27	26	25	24
								URAD
Access								W
Reset								0
Bit	23	22	21	20	19	18	17	16
	RSU[3:0]				REC[3:0]			
Access	W	W	W	W	W	W	W	W
Reset	0	0	0	0	0	0	0	0
Bit	15	14	13	12	11	10	9	8
	RWC[3:0]				RBE[3:0]			
Access	W	W	W	W	W	W	W	W
Reset	0	0	0	0	0	0	0	0
Bit	7	6	5	4	3	2	1	0
	RDM[3:0]				RHC[3:0]			
Access	W	W	W	W	W	W	W	W
Reset	0	0	0	0	0	0	0	0

**Bit 24 – URAD** Undefined Register Access Detection Interrupt Enable

0: No effect  
 1: The Undefined Register Access interrupt is enabled.

**Bits 23:20 – RSU[3:0]** Region Status Updated Interrupt Enable

0: No effect  
 1: When RSU[i] is written to '1', the region i Status Updated interrupt is enabled.

**Bits 19:16 – REC[3:0]** Region End bit Condition Detected Interrupt Enable

0: No effect  
 1: When REC[i] is written to '1', the region i End bit Condition interrupt is enabled.

**Bits 15:12 – RWC[3:0]** Region Wrap Condition detected Interrupt Enable

0: No effect  
 1: When RWC[i] is written to '1', the Region i Wrap Condition interrupt is enabled.

**Bits 11:8 – RBE[3:0]** Region Bus Error Interrupt Enable

Value	Description
0	No effect.
1	When RBE[i] is written to '1', the Region i Bus Error interrupt is enabled.

**Bits 7:4 – RDM[3:0]** Region Digest Mismatch Interrupt Enable

# SAM D5x/E5x Family Data Sheet

## ICM - Integrity Check Monitor

---

---

Value	Description
0	No effect.
1	When RDM[i] is written to '1', the Region i Digest Mismatch interrupt is enabled.

### Bits 3:0 – RHC[3:0] Region Hash Completed Interrupt Enable

Value	Description
0	No effect.
1	When RHC[i] is written to '1', the Region i Hash Completed interrupt is enabled.



# SAM D5x/E5x Family Data Sheet

## ICM - Integrity Check Monitor

### 26.8.5 Interrupt Disable Register

**Name:** IDR  
**Offset:** 0x14  
**Property:** Write-Only

	Bit	31	30	29	28	27	26	25	24
		[Greyed out bits 31-25]							URAD
Access									W
Reset									
	Bit	23	22	21	20	19	18	17	16
		RSU[3:0]				REC[3:0]			
Access		W	W	W	W	W	W	W	W
Reset									
	Bit	15	14	13	12	11	10	9	8
		RWC[3:0]				RBE[3:0]			
Access		W	W	W	W	W	W	W	W
Reset									
	Bit	7	6	5	4	3	2	1	0
		RDM[3:0]				RHC[3:0]			
Access		W	W	W	W	W	W	W	W
Reset									

**Bit 24 – URAD** Undefined Register Access Detection Interrupt Disable

Value	Description
0	No effect.
1	Undefined Register Access Detection interrupt is disabled.

**Bits 23:20 – RSU[3:0]** Region Status Updated Interrupt Disable

Value	Description
0	No effect.
1	When RSU[i] is written to '1', the region i Status Updated interrupt is disabled.

**Bits 19:16 – REC[3:0]** Region End bit Condition detected Interrupt Disable

Value	Description
0	No effect.
1	When REC[i] is written to '1', the region i End bit Condition interrupt is disabled.

**Bits 15:12 – RWC[3:0]** Region Wrap Condition Detected Interrupt Disable

Value	Description
0	No effect.
1	When RWC[i] is written to '1', the Region i Wrap Condition interrupt is disabled.

**Bits 11:8 – RBE[3:0]** Region Bus Error Interrupt Disable

# SAM D5x/E5x Family Data Sheet

## ICM - Integrity Check Monitor

---

---

Value	Description
0	No effect.
1	When RBE[i] is written to '1', the Region i Bus Error interrupt is disabled.

### Bits 7:4 – RDM[3:0] Region Digest Mismatch Interrupt Disable

Value	Description
0	No effect.
1	When RDM[i] is written to '1', the Region i Digest Mismatch interrupt is disabled.

### Bits 3:0 – RHC[3:0] Region Hash Completed Interrupt Disable

Value	Description
0	No effect.
1	When RHC[i] is written to '1', the Region i Hash Completed interrupt is disabled.

# SAM D5x/E5x Family Data Sheet

## ICM - Integrity Check Monitor

### 26.8.6 Interrupt Mask Register

**Name:** IMR  
**Offset:** 0x18  
**Reset:** 0x00000000  
**Property:** Read-Only

	Bit	31	30	29	28	27	26	25	24
		[Greyed out bits]							URAD
Access									R
Reset									0
	Bit	23	22	21	20	19	18	17	16
		RSU[3:0]				REC[3:0]			
Access		R	R	R	R	R	R	R	R
Reset		0	0	0	0	0	0	0	0
	Bit	15	14	13	12	11	10	9	8
		RWC[3:0]				RBE[3:0]			
Access		R	R	R	R	R	R	R	R
Reset		0	0	0	0	0	0	0	0
	Bit	7	6	5	4	3	2	1	0
		RDM[3:0]				RHC[3:0]			
Access		R	R	R	R	R	R	R	R
Reset		0	0	0	0	0	0	0	0

#### Bit 24 – URAD Undefined Register Access Detection Interrupt Mask

Value	Description
0	The interrupt is disabled.
1	The interrupt is enabled.

#### Bits 23:20 – RSU[3:0] Region Status Updated Interrupt Mask

Value	Description
0	When RSU[i] is reading '0', the interrupt is disabled for region i.
1	When RSU[i] is reading '1', the interrupt is enabled for region i.

#### Bits 19:16 – REC[3:0] Region End bit Condition Detected Interrupt Mask

Value	Description
0	When REC[i] is reading '0', the interrupt is disabled for region i.
1	When REC[i] is reading '1', the interrupt is enabled for region i.

#### Bits 15:12 – RWC[3:0] Region Wrap Condition Detected Interrupt Mask

Value	Description
0	When RWC[i] is reading '0', the interrupt is disabled for region i.
1	When RWC[i] is reading '1', the interrupt is enabled for region i.

#### Bits 11:8 – RBE[3:0] Region Bus Error Interrupt Mask

# SAM D5x/E5x Family Data Sheet

## ICM - Integrity Check Monitor

---

---

Value	Description
0	When RBE[i] is reading '0', the interrupt is disabled for region i.
1	When RBE[i] is reading '1', the interrupt is enabled for region i.

### Bits 7:4 – RDM[3:0] Region Digest Mismatch Interrupt Mask

Value	Description
0	When RDM[i] is reading '0', the interrupt is disabled for region i.
1	When RDM[i] is reading '1', the interrupt is enabled for region i.

### Bits 3:0 – RHC[3:0] Region Hash Completed Interrupt Mask

Value	Description
0	When RHC[i] is reading '0', the interrupt is disabled for region i.
1	When RHC[i] is reading '1', the interrupt is enabled for region i.

# SAM D5x/E5x Family Data Sheet

## ICM - Integrity Check Monitor

### 26.8.7 Interrupt Status Register

**Name:** ISR  
**Offset:** 0x1C  
**Reset:** 0x0  
**Property:** Read-Only

	Bit	31	30	29	28	27	26	25	24
									URAD
Access									R
Reset									0
	Bit	23	22	21	20	19	18	17	16
		RSU[3:0]				REC[3:0]			
Access		R	R	R	R	R	R	R	R
Reset		0	0	0	0	0	0	0	0
	Bit	15	14	13	12	11	10	9	8
		RWC[3:0]				RBE[3:0]			
Access		R	R	R	R	R	R	R	R
Reset		0	0	0	0	0	0	0	0
	Bit	7	6	5	4	3	2	1	0
		RDM[3:0]				RHC[3:0]			
Access		R	R	R	R	R	R	R	R
Reset		0	0	0	0	0	0	0	0

**Bit 24 – URAD** Undefined Register Access Detection Status

The URAD bit is only reset by the SWRST bit in the CTRL register.

The Undefined Register Access Trace bit field in the Undefined Access Status Register (UASR.URAT) indicates the unspecified access type.

Value	Description
0	No undefined register access has been detected since the last SWRST.
1	At least one undefined register access has been detected since the last SWRST.

**Bits 23:20 – RSU[3:0]** Region Status Updated Detected

RSU[i] is set when a region status updated condition is detected.

**Bits 19:16 – REC[3:0]** Region End bit Condition Detected

REC[i] is set when an end bit condition is detected.

**Bits 15:12 – RWC[3:0]** Region Wrap Condition Detected

RWC[i] is set when a wrap condition is detected.

**Bits 11:8 – RBE[3:0]** Region Bus Error

RBE[i] is set when a bus error is detected while hashing memory region i.

# SAM D5x/E5x Family Data Sheet

## ICM - Integrity Check Monitor

---

---

**Bits 7:4 – RDM[3:0]** Region Digest Mismatch

RDM[i] is set when there is a digest comparison mismatch between the hash value of region i and the reference value located in the Hash Area.

**Bits 3:0 – RHC[3:0]** Region Hash Completed

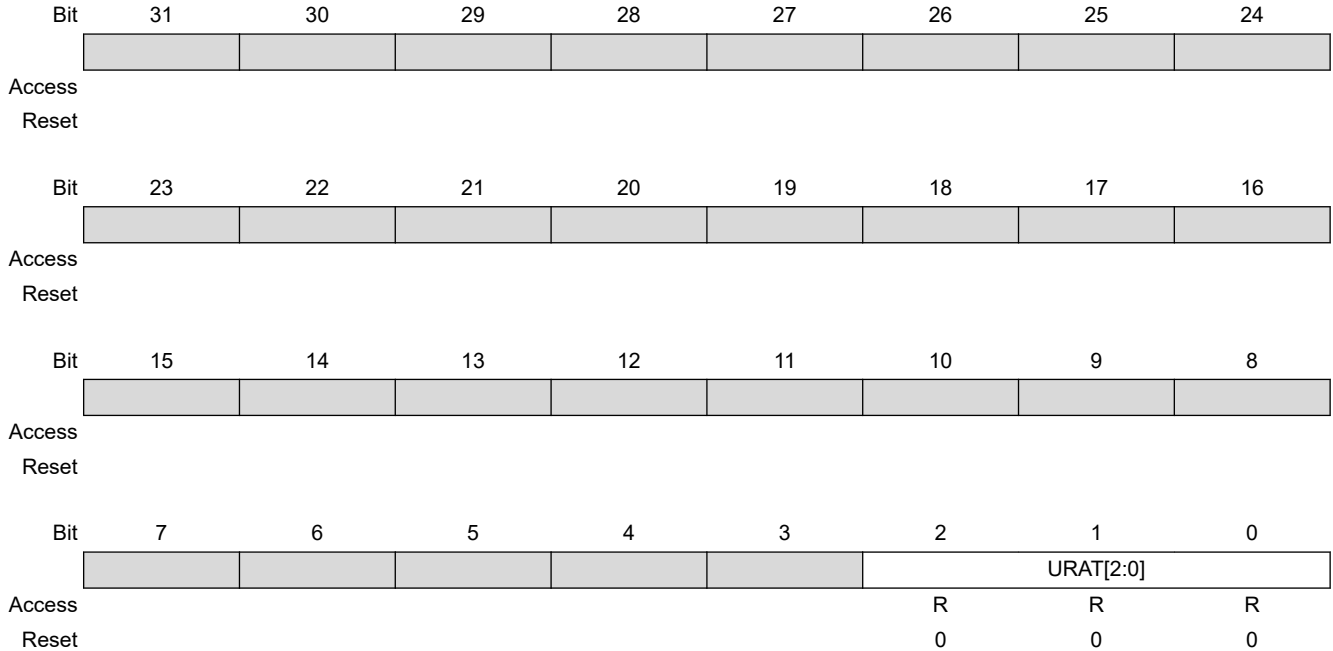
RHC[i] is set when the ICM has completed the region with identifier i.

# SAM D5x/E5x Family Data Sheet

## ICM - Integrity Check Monitor

### 26.8.8 Undefined Access Status Register

**Name:** UASR  
**Offset:** 0x20  
**Reset:** 0x0  
**Property:** Read-Only



#### Bits 2:0 – URAT[2:0] Undefined Register Access Trace

Only the first Undefined Register Access Trace is available through the URAT field.

The URAT field is only reset by the Software Reset bit in the Control register (CTRL.SWRST).

Value	Name	Description
0	UNSPEC_STRUCT_MEMBER	Unspecified structure member set to '1' detected when the descriptor is loaded.
1	ICM_CFG_MODIFIED	CFG modified during active monitoring.
2	ICM_DSCR_MODIFIED	DSCR modified during active monitoring.
3	ICM_HASH_MODIFIED	HASH modified during active monitoring.
4	READ_ACCESS	Write-only register read access
		Only the first Undefined Register Access Trace is available through the URAT field.
		The URAT field is only reset by the SWRST bit in the CTRL register.

# SAM D5x/E5x Family Data Sheet

## ICM - Integrity Check Monitor

### 26.8.9 Descriptor Area Start Address Register

**Name:** DSCR  
**Offset:** 0x30  
**Reset:** 0x0  
**Property:** -

	Bit	31	30	29	28	27	26	25	24
		DASA[25:18]							
Access		R/W	R/W	R/W	R/W	R/W	R/W	R/W	R/W
Reset		0	0	0	0	0	0	0	0
	Bit	23	22	21	20	19	18	17	16
		DASA[17:10]							
Access		R/W	R/W	R/W	R/W	R/W	R/W	R/W	R/W
Reset		0	0	0	0	0	0	0	0
	Bit	15	14	13	12	11	10	9	8
		DASA[9:2]							
Access		R/W	R/W	R/W	R/W	R/W	R/W	R/W	R/W
Reset		0	0	0	0	0	0	0	0
	Bit	7	6	5	4	3	2	1	0
		DASA[1:0]							
Access		R/W	R/W						
Reset		0	0						

**Bits 31:6 – DASA[25:0]** Descriptor Area Start Address

The start address is a multiple of the total size of the data structure (64 bytes).



# SAM D5x/E5x Family Data Sheet

## ICM - Integrity Check Monitor

### 26.8.10 Hash Area Start Address Register

**Name:** HASH  
**Offset:** 0x34  
**Reset:** 0x00000000  
**Property:** -

	Bit	31	30	29	28	27	26	25	24
		HASA[24:17]							
Access		R/W	R/W	R/W	R/W	R/W	R/W	R/W	R/W
Reset		0	0	0	0	0	0	0	0
	Bit	23	22	21	20	19	18	17	16
		HASA[16:9]							
Access		R/W	R/W	R/W	R/W	R/W	R/W	R/W	R/W
Reset		0	0	0	0	0	0	0	0
	Bit	15	14	13	12	11	10	9	8
		HASA[8:1]							
Access		R/W	R/W	R/W	R/W	R/W	R/W	R/W	R/W
Reset		0	0	0	0	0	0	0	0
	Bit	7	6	5	4	3	2	1	0
		HASA[0:0]							
Access		R/W							
Reset		0							

**Bits 31:7 – HASA[24:0]** Hash Area Start Address

This field points at the Hash memory location. The address must be a multiple of 128 bytes.

# SAM D5x/E5x Family Data Sheet

## ICM - Integrity Check Monitor

### 26.8.11 User Initial Hash Value Register

**Name:** UIHVALx  
**Offset:** 0x38 + x\*0x04 [x=0..7]  
**Reset:** 0  
**Property:** -

	Bit	31	30	29	28	27	26	25	24
		VAL[31:24]							
Access		R/W	R/W	R/W	R/W	R/W	R/W	R/W	R/W
Reset		0	0	0	0	0	0	0	0
	Bit	23	22	21	20	19	18	17	16
		VAL[23:16]							
Access		R/W	R/W	R/W	R/W	R/W	R/W	R/W	R/W
Reset		0	0	0	0	0	0	0	0
	Bit	15	14	13	12	11	10	9	8
		VAL[15:8]							
Access		R/W	R/W	R/W	R/W	R/W	R/W	R/W	R/W
Reset		0	0	0	0	0	0	0	0
	Bit	7	6	5	4	3	2	1	0
		VAL[7:0]							
Access		R/W	R/W	R/W	R/W	R/W	R/W	R/W	R/W
Reset		0	0	0	0	0	0	0	0

#### Bits 31:0 – VAL[31:0] Initial Hash Value

When UIHASH bit of CFG register is set, the Initial Hash Value is user-programmable.

To meet the desired standard, use the following example values.

For UIHVAL0 field:

Example	Comment
0x67452301	SHA1 algorithm
0xC1059ED8	SHA224 algorithm
0x6A09E667	SHA256 algorithm

For UIHVAL1 field:

Example	Comment
0xEFCDAB89	SHA1 algorithm
0x367CD507	SHA224 algorithm
0xBB67AE85	SHA256 algorithm

For UIHVAL2 field:

# SAM D5x/E5x Family Data Sheet

## ICM - Integrity Check Monitor

Example	Comment
0x98BADCFE	SHA1 algorithm
0x3070DD17	SHA224 algorithm
0x3C6EF372	SHA256 algorithm

For UIHVAL3 field:

Example	Comment
0x10325476	SHA1 algorithm
0xF70E5939	SHA224 algorithm
0xA54FF53A	SHA256 algorithm

For UIHVAL4 field:

Example	Comment
0xC3D2E1F0	SHA1 algorithm
0xFFC00B31	SHA224 algorithm
0x510E527F	SHA256 algorithm

For UIHVAL5 field:

Example	Comment
0x68581511	SHA224 algorithm
0x9B05688C	SHA256 algorithm

For UIHVAL6 field:

Example	Comment
0x64F98FA7	SHA224 algorithm
0x1F83D9AB	SHA256 algorithm

For UIHVAL7 field:

Example	Comment
0xBEFA4FA4	SHA224 algorithm
0x5BE0CD19	SHA256 algorithm

Example of Initial Value for SHA-1 Algorithm

Register Address	Address Offset / Byte Lane			
	0x3 / 31:24	0x2 / 23:16	0x1 / 15:8	0x0 / 7:0
0x000 UIHVAL0	01	23	45	67

# SAM D5x/E5x Family Data Sheet

## ICM - Integrity Check Monitor

.....continued

Register Address	Address Offset / Byte Lane			
	0x3 / 31:24	0x2 / 23:16	0x1 / 15:8	0x0 / 7:0
0x004 UIHVAL1	89	ab	cd	ef
0x008 UIHVAL2	fe	dc	ba	98
0x00C UIHVAL3	76	54	32	10
0x010 UIHVAL4	f0	e1	d2	c3

## 27. PAC - Peripheral Access Controller

### 27.1 Overview

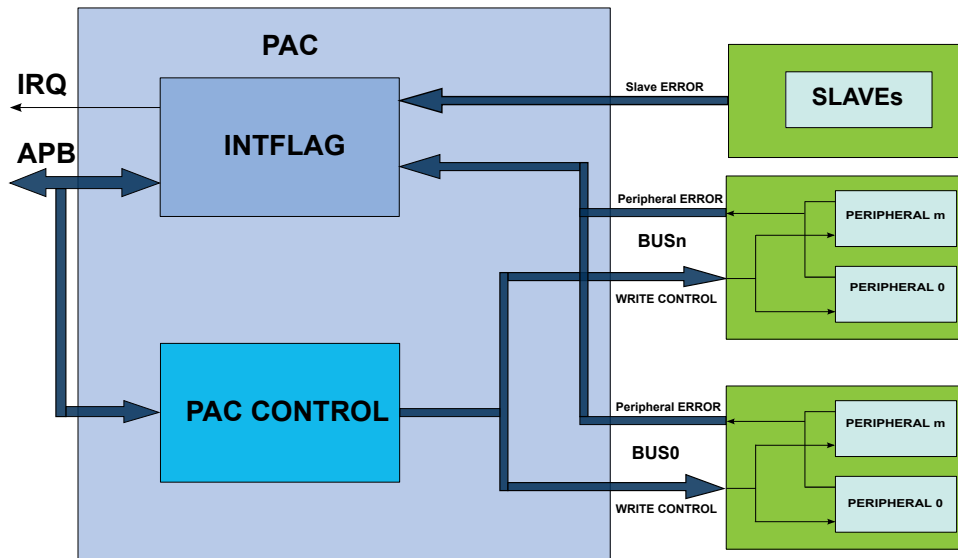
The Peripheral Access Controller provides an interface for the locking and unlocking of peripheral registers within the device. It reports all violations that could happen when accessing a peripheral: write protected access, illegal access, enable protected access, access when clock synchronization or software reset is on-going. These errors are reported in a unique interrupt flag for a peripheral. The PAC module also reports errors occurring at the slave bus level, when an access to a non-existing address is detected.

### 27.2 Features

- Manages write protection access and reports access errors for the peripheral modules or bridges.

### 27.3 Block Diagram

Figure 27-1. PAC Block Diagram



### 27.4 Product Dependencies

In order to use this peripheral, other parts of the system must be configured correctly, as described below.

#### 27.4.1 IO Lines

Not applicable.

#### 27.4.2 Power Management

The PAC can continue to operate in any Sleep mode where the selected source clock is running. The PAC interrupts can be used to wake up the device from Sleep modes. The events can trigger other operations in the system without exiting sleep modes.

### Related Links

[18. PM – Power Manager](#)

#### 27.4.3 Clocks

The PAC bus clock (CLK\_PAC\_APB) can be enabled and disabled in the Main Clock module. The default state of CLK\_PAC\_APB can be found in the related links.

### Related Links

[15. MCLK – Main Clock](#)  
[15.6.2.6 Peripheral Clock Masking](#)

#### 27.4.4 DMA

Not applicable.

#### 27.4.5 Interrupts

The interrupt request line is connected to the Interrupt Controller. Using the PAC interrupt requires the Interrupt Controller to be configured first.

**Table 27-1. Interrupt Lines**

Instances	NVIC Line
PAC	ERR

### Related Links

[10.2 Nested Vector Interrupt Controller](#)

#### 27.4.6 Events

The events are connected to the Event System, which may need configuration.

### Related Links

[31. EVSYS – Event System](#)

#### 27.4.7 Debug Operation

When the CPU is halted in Debug mode, write protection of all peripherals is disabled and the PAC continues normal operation.

#### 27.4.8 Register Access Protection

All registers with write access can be write-protected optionally by the Peripheral Access Controller (PAC), except for the following registers:

- Write Control (WRCTRL) register
- AHB Slave Bus Interrupt Flag Status and Clear (INTFLAGAHB) register
- Peripheral Interrupt Flag Status and Clear n (INTFLAG A/B/C...) registers

Optional write protection by the Peripheral Access Controller (PAC) is denoted by the "PAC Write Protection" property in each individual register description.

PAC write protection does not apply to accesses through an external debugger.

## 27.5 Functional Description

### 27.5.1 Principle of Operation

The Peripheral Access Control module allows the user to set a write protection on peripheral modules and generate an interrupt in case of a peripheral access violation. The peripheral's protection can be set, cleared or locked at the user discretion. A set of Interrupt Flag and Status registers informs the user on the status of the violation in the peripherals. In addition, slaves bus errors can be also reported in the cases where reserved area is accessed by the application.

### 27.5.2 Basic Operation

#### 27.5.2.1 Initialization, Enabling and Resetting

The PAC is always enabled after reset.

Only a hardware reset will reset the PAC module.

#### 27.5.2.2 Operations

The PAC module allows the user to set, clear or lock the write protection status of all peripherals on all Peripheral Bridges.

If a peripheral register violation occurs, the Peripheral Interrupt Flag n registers (INTFLAGn) are updated to inform the user on the status of the violation in the peripherals connected to the Peripheral Bridge n (n = A,B,C ...). The corresponding Peripheral Write Control Status n register (STATUSn) gives the state of the write protection for all peripherals connected to the corresponding Peripheral Bridge n. Refer to [27.5.2.3 Peripheral Access Errors](#) for details.

The PAC module also report the errors occurring at slave bus level when an access to reserved area is detected. AHB Slave Bus Interrupt Flag register (INTFLAGAHB) informs the user on the status of the violation in the corresponding slave. Refer to the [27.5.2.6 AHB Slave Bus Errors](#) for details.

#### 27.5.2.3 Peripheral Access Errors

The following events will generate a Peripheral Access Error:

- Protected write: To avoid unexpected writes to a peripheral's registers, each peripheral can be write protected. Only the registers denoted as "PAC Write-Protection" in the module's datasheet can be protected. If a peripheral is not write protected, write data accesses are performed normally. If a peripheral is write protected and if a write access is attempted, data will not be written and peripheral returns an access error. The corresponding interrupt flag bit in the INTFLAGn register will be set.
- Illegal access: Access to an unimplemented register within the module.
- Synchronized write error: For write-synchronized registers an error will be reported if the register is written while a synchronization is ongoing.

When any of the INTFLAGn registers bit are set, an interrupt will be requested if the PAC interrupt enable bit is set.

#### Related Links

[13.3 Register Synchronization](#)

#### 27.5.2.4 Write Access Protection Management

Peripheral access control can be enabled or disabled by writing to the WRCTRL register.

The data written to the WRCTRL register is composed of two fields; WRCTRL.PERID and WRCTRL.KEY. The WRCTRL.PERID is a unique identifier corresponding to a peripheral. The WRCTRL.KEY is a key

value that defines the operation to be done on the control access bit. These operations can be “clear protection”, “set protection” and “set and lock protection bit”.

The “clear protection” operation will remove the write access protection for the peripheral selected by WRCTRL.PERID. Write accesses are allowed for the registers in this peripheral.

The “set protection” operation will set the write access protection for the peripheral selected by WRCTRL.PERID. Write accesses are not allowed for the registers with write protection property in this peripheral.

The “set and lock protection” operation will set the write access protection for the peripheral selected by WRCTRL.PERID and locks the access rights of the selected peripheral registers. The write access protection will only be cleared by a hardware reset.

The peripheral access control status can be read from the corresponding STATUSn register.

### 27.5.2.5 Write Access Protection Management Errors

Only word-wise writes to the WRCTRL register will effectively change the access protection. Other type of accesses will have no effect and will cause a PAC write access error. This error is reported in the INTFLAGn.PAC bit corresponding to the PAC module.

PAC also offers an additional safety feature for correct program execution with an interrupt generated on double write clear protection or double write set protection. If a peripheral is write protected and a subsequent set protection operation is detected then the PAC returns an error, and similarly for a double clear protection operation.

In addition, an error is generated when writing a “set and lock” protection to a write-protected peripheral or when a write access is done to a locked set protection. This can be used to ensure that the application follows the intended program flow by always following a write protect with an unprotect and conversely. However in applications where a write protected peripheral is used in several contexts, e.g. interrupt, care should be taken so that either the interrupt can not happen while the main application or other interrupt levels manipulates the write protection status or when the interrupt handler needs to unprotect the peripheral based on the current protection status by reading the STATUS register.

The errors generated while accessing the PAC module registers (eg. key error, double protect error...) will set the INTFLAGn.PAC flag.

### 27.5.2.6 AHB Slave Bus Errors

The PAC module reports errors occurring at the AHB Slave bus level. These errors are generated when an access is performed at an address where no slave (bridge or peripheral) is mapped . These errors are reported in the corresponding bits of the INTFLAGAHB register.

### 27.5.2.7 Generating Events

The PAC module can also generate an event when any of the Interrupt Flag registers bit are set. To enable the PAC event generation, the control bit EVCTRL.ERREO must be set a '1'.

### 27.5.3 DMA Operation

Not applicable.

### 27.5.4 Interrupts

The PAC has the following interrupt source:

- Error (ERR): Indicates that a peripheral access violation occurred in one of the peripherals controlled by the PAC module, or a bridge error occurred in one of the bridges reported by the PAC
  - This interrupt is a synchronous wake-up source.



Each interrupt source has an interrupt flag associated with it. The interrupt flag in the Interrupt Flag Status and Clear (INTFLAGAHB and INTFLAGn) registers is set when the interrupt condition occurs. Each interrupt can be individually enabled by writing a '1' to the corresponding bit in the Interrupt Enable Set (INTENSET) register, and disabled by writing a '1' to the corresponding bit in the Interrupt Enable Clear (INTENCLR) register. An interrupt request is generated when the interrupt flag is set and the corresponding interrupt is enabled. The interrupt request remains active until the interrupt flag is cleared, the interrupt is disabled, or the PAC is reset. All interrupt requests from the peripheral are ORed together on system level to generate one combined interrupt request to the NVIC. The user must read the INTFLAGAHB and INTFLAGn registers to determine which interrupt condition is present.

Note that interrupts must be globally enabled for interrupt requests to be generated.

### Related Links

[10.2 Nested Vector Interrupt Controller](#)

#### 27.5.5 Events

The PAC can generate the following output event:

- Error (ERR): Generated when one of the interrupt flag registers bits is set

Writing a '1' to an Event Output bit in the Event Control Register (EVCTRL.ERREO) enables the corresponding output event. Writing a '0' to this bit disables the corresponding output event.

#### 27.5.6 Sleep Mode Operation

In Sleep mode, the PAC is kept enabled if an available bus master (CPU, DMA) is running. The PAC will continue to catch access errors from the module and generate interrupts or events.

#### 27.5.7 Synchronization

Not applicable.

# SAM D5x/E5x Family Data Sheet

## PAC - Peripheral Access Controller

### 27.6 Register Summary

Offset	Name	Bit Pos.									
0x00	WRCTRL	7:0	PERID[7:0]								
		15:8	PERID[15:8]								
		23:16	KEY[7:0]								
		31:24									
0x04	EVCTRL	7:0								ERREO	
0x05 ... 0x07	Reserved										
0x08	INTENCLR	7:0								ERR	
0x09	INTENSET	7:0								ERR	
0x0A ... 0x0F	Reserved										
0x10	INTFLGAHB	7:0	HPB0	RAMDMACIM	RAMDMAWR	RAMPPDSU	RAMCM4S	NVMCTRL2	NVMCTRL1	NVMCTRL0	
		15:8		QSPI	SDHC1	SDHC0	PUKCC	HPB3	HPB2	HPB1	
		23:16									
		31:24									
0x14	INTFLAGA	7:0	GCLK	SUPC	OSC32KCTRL	OSCCTRL	RSTC	MCLK	PM	PAC	
		15:8	TC1	TC0	SERCOM1	SERCOM0	FREQM	EIC	RTC	WDT	
		23:16									
		31:24									
0x18	INTFLAGB	7:0	EVSYS		DMAC	PORT	CMCC	NVMCTRL	DSU	USB	
		15:8		TC3	TC2	TCC1	TCC0	SERCOM3	SERCOM2		
		23:16									RAMECC
		31:24									
0x1C	INTFLAGC	7:0	PDEC	TC5	TC4	TCC3	TCC2	GMAC	CAN1	CAN0	
		15:8		CCL	QSPI	PUKCC	ICM	TRNG	AES		
		23:16									
		31:24									
0x20	INTFLAGD	7:0	ADC0	TC7	TC6	TCC4	SERCOM7	SERCOM6	SERCOM5	SERCOM4	
		15:8					PCC	I2S	DAC	ADC1	
		23:16									
		31:24									
0x24 ... 0x33	Reserved										
0x34	STATUSA	7:0	GCLK	SUPC	OSC32KCTRL	OSCCTRL	RSTC	MCLK	PM	PAC	
		15:8	TC1	TC0	SERCOM1	SERCOM0	FREQM	EIC		WDT	
		23:16									
		31:24									

# SAM D5x/E5x Family Data Sheet

## PAC - Peripheral Access Controller

.....continued

Offset	Name	Bit Pos.								
0x38	STATUSB	7:0	EVSYS		DMAC	PORT	CMCC	NVMCTRL	DSU	USB
		15:8		TC3	TC2	TCC1	TCC0	SERCOM3	SERCOM2	
		23:16								RAMECC
		31:24								
0x3C	STATUSC	7:0	PDEC	TC5	TC4	TCC3	TCC2	GMAC	CAN1	CAN0
		15:8		CCL	QSPI	PUKCC	ICM	TRNG	AES	AC
		23:16								
		31:24								
0x40	STATUSD	7:0	ADC0	TC7	TC6	TCC4	SERCOM7	SERCOM6	SERCOM5	SERCOM4
		15:8					PCC	I2S	DAC	ADC1
		23:16								
		31:24								

### 27.7 Register Description

Registers can be 8, 16, or 32 bits wide. Atomic 8-, 16- and 32-bit accesses are supported. In addition, the 8-bit quarters and 16-bit halves of a 32-bit register, and the 8-bit halves of a 16-bit register can be accessed directly.

Some registers are optionally write-protected by the Peripheral Access Controller (PAC). Optional PAC write protection is denoted by the "PAC Write-Protection" property in each individual register description. For details, refer to the related links.

#### Related Links

[13.3 Register Synchronization](#)

# SAM D5x/E5x Family Data Sheet

## PAC - Peripheral Access Controller

### 27.7.1 Write Control

**Name:** WRCTRL  
**Offset:** 0x00  
**Reset:** 0x00000000  
**Property:** –

	Bit	31	30	29	28	27	26	25	24
		[Greyed out bit fields]							
Access									
Reset									
	Bit	23	22	21	20	19	18	17	16
		KEY[7:0]							
Access		RW	RW	RW	RW	RW	RW	RW	RW
Reset		0	0	0	0	0	0	0	0
	Bit	15	14	13	12	11	10	9	8
		PERID[15:8]							
Access		RW	RW	RW	RW	RW	RW	RW	RW
Reset		0	0	0	0	0	0	0	0
	Bit	7	6	5	4	3	2	1	0
		PERID[7:0]							
Access		RW	RW	RW	RW	RW	RW	RW	RW
Reset		0	0	0	0	0	0	0	0

#### Bits 23:16 – KEY[7:0] Peripheral Access Control Key

These bits define the peripheral access control key:

Value	Name	Description
0x0	OFF	No action
0x1	CLEAR	Clear the peripheral write control
0x2	SET	Set the peripheral write control
0x3	LOCK	Set and lock the peripheral write control until the next hardware reset

#### Bits 15:0 – PERID[15:0] Peripheral Identifier

The PERID represents the peripheral whose control is changed using the WRCTRL.KEY. The Peripheral Identifier is calculated following formula:

$$PERID = 32 * BridgeNumber + N$$

Where BridgeNumber represents the Peripheral Bridge Number (0 for Peripheral Bridge A, 1 for Peripheral Bridge B, etc). N represents the peripheral index from the respective Bridge Number:

**Table 27-2. PERID Values**

Periph. Bridge Name	BridgeNumber	PERID Values
A	0	0+N
B	1	32+N
C	2	64+N

# SAM D5x/E5x Family Data Sheet

## PAC - Peripheral Access Controller

.....continued

Periph. Bridge Name	BridgeNumber	PERID Values
D	3	96+N
E	4	128+N

# SAM D5x/E5x Family Data Sheet

## PAC - Peripheral Access Controller

### 27.7.2 Event Control

**Name:** EVCTRL  
**Offset:** 0x04  
**Reset:** 0x00  
**Property:** -

Bit	7	6	5	4	3	2	1	0
								ERREO
Access								RW
Reset								0

#### Bit 0 – ERREO Peripheral Access Error Event Output

This bit indicates if the Peripheral Access Error Event Output is enabled or disabled. When enabled, an event will be generated when one of the interrupt flag registers bits (INTFLAGAHB, INTFLAGn) is set:

Value	Description
0	Peripheral Access Error Event Output is disabled.
1	Peripheral Access Error Event Output is enabled.

### 27.7.3 Interrupt Enable Clear

**Name:** INTENCLR  
**Offset:** 0x08  
**Reset:** 0x00  
**Property:** PAC Write-Protection

This register allows the user to disable an interrupt without doing a read-modify-write operation. Changes in this register will also be reflected in the Interrupt Enable Set register (INTENSET).

	7	6	5	4	3	2	1	0
Bit								ERR
Access								RW
Reset								0

**Bit 0 – ERR** Peripheral Access Error Interrupt Disable

This bit indicates that the Peripheral Access Error Interrupt is disabled and an interrupt request will be generated when one of the interrupt flag registers bits (INTFLAGAHB, INTFLAGn) is set:

Writing a '0' to this bit has no effect.

Writing a '1' to this bit will clear the Peripheral Access Error interrupt Enable bit and disables the corresponding interrupt request.

Value	Description
0	Peripheral Access Error interrupt is disabled.
1	Peripheral Access Error interrupt is enabled.

### 27.7.4 Interrupt Enable Set

**Name:** INTENSET  
**Offset:** 0x09  
**Reset:** 0x00  
**Property:** PAC Write-Protection

This register allows the user to enable an interrupt without doing a read-modify-write operation. Changes in this register will also be reflected in the Interrupt Enable Set register (INTENCLR).

	7	6	5	4	3	2	1	0
								ERR
Access								RW
Reset								0

**Bit 0 – ERR** Peripheral Access Error Interrupt Enable

This bit indicates that the Peripheral Access Error Interrupt is enabled and an interrupt request will be generated when one of the interrupt flag registers bits (INTFLAGAHB, INTFLAGn) is set:

Writing a '0' to this bit has no effect.

Writing a '1' to this bit will set the Peripheral Access Error interrupt Enable bit and enables the corresponding interrupt request.

Value	Description
0	Peripheral Access Error interrupt is disabled.
1	Peripheral Access Error interrupt is enabled.



# SAM D5x/E5x Family Data Sheet

## PAC - Peripheral Access Controller

### 27.7.5 Bridge Interrupt Flag Status

**Name:** INTFLAGAHB  
**Offset:** 0x10  
**Reset:** 0x00000000  
**Property:** -

These flags are cleared by writing a '1' to the corresponding bit.

These flags are set when an access error is detected by the corresponding AHB slave, and will generate an interrupt request if INTENCLR/SET.ERR is '1'.

Bit	31	30	29	28	27	26	25	24
Access								
Reset								
Bit	23	22	21	20	19	18	17	16
Access								
Reset								
Bit	15	14	13	12	11	10	9	8
		QSPI	SDHC1	SDHC0	PUKCC	HPB3	HPB2	HPB1
Access		RW	RW	RW	RW	RW	RW	RW
Reset		0	0	0	0	0	0	0
Bit	7	6	5	4	3	2	1	0
	HPB0	RAMDMACICM	RAMDMAWR	RAMPPDSU	RAMCM4S	NVMCTRL2	NVMCTRL1	NVMCTRL0
Access	RW	RW	RW	RW	RW	RW	RW	RW
Reset	0	0	0	0	0	0	0	0

**Bit 14 – QSPI** Interrupt Flag for QSPI

This flag is set when an access error is detected by the QSPI AHB slave, and will generate an interrupt request if INTENCLR/SET.ERR is '1'.

Writing a '0' has no effect.

Writing a '1' to this bit will clear the QSPI interrupt flag.

**Bit 13 – SDHC1** Interrupt Flag for SDHC1

This flag is set when an access error is detected by the SDHC1 AHB slave, and will generate an interrupt request if INTENCLR/SET.ERR is '1'.

Writing a '0' has no effect.

Writing a '1' to this bit will clear the SDHC1 interrupt flag.

**Bit 12 – SDHC0** Interrupt Flag for SDHC0

This flag is set when an access error is detected by the SDHC0 AHB slave, and will generate an interrupt request if INTENCLR/SET.ERR is '1'.

Writing a '0' has no effect.

Writing a '1' to this bit will clear the SDHC0 interrupt flag.

**Bit 11 – PUKCC** Interrupt Flag for PUKCC

This flag is set when an access error is detected by the PUKCC AHB slave, and will generate an interrupt request if INTENCLR/SET.ERR is '1'.

Writing a '0' has no effect.

Writing a '1' to this bit will clear the PUKCC interrupt flag.

**Bit 10 – HPB3** Interrupt Flag for HPB3

This flag is set when an access error is detected by the HPB3 AHB slave, and will generate an interrupt request if INTENCLR/SET.ERR is '1'.

Writing a '0' has no effect.

Writing a '1' to this bit will clear the HPB3 interrupt flag.

**Bit 9 – HPB2** Interrupt Flag for HPB2

This flag is set when an access error is detected by the HPB2 AHB slave, and will generate an interrupt request if INTENCLR/SET.ERR is '1'.

Writing a '0' has no effect.

Writing a '1' to this bit will clear the HPB2 interrupt flag.

**Bit 8 – HPB1** Interrupt Flag for HPB1

This flag is set when an access error is detected by the HPB1 AHB slave, and will generate an interrupt request if INTENCLR/SET.ERR is '1'.

Writing a '0' has no effect.

Writing a '1' to this bit will clear the HPB1 interrupt flag.

**Bit 7 – HPB0** Interrupt Flag for HPB0

This flag is set when an access error is detected by the HPB0 AHB slave, and will generate an interrupt request if INTENCLR/SET.ERR is '1'.

Writing a '0' has no effect.

Writing a '1' to this bit will clear the HPB0 interrupt flag.

**Bit 6 – RAMDMACICM** Interrupt Flag for RAMDMACICM

This flag is set when an access error is detected by the RAMDMACICM AHB slave, and will generate an interrupt request if INTENCLR/SET.ERR is '1'.

Writing a '0' has no effect.

Writing a '1' to this bit will clear the RAMDMACICM interrupt flag.

**Bit 5 – RAMDMAWR** Interrupt Flag for RAMDMAWR

This flag is set when an access error is detected by the RAMDMAWR AHB slave, and will generate an interrupt request if INTENCLR/SET.ERR is '1'.

Writing a '0' has no effect.

Writing a '1' to this bit will clear the RAMDMAWR interrupt flag.

**Bit 4 – RAMPPDSU** Interrupt Flag for RAMPPDSU:

This flag is set when an access error is detected by the RAMPPDSU AHB slave, and will generate an interrupt request if INTENCLR/SET.ERR is '1'.

Writing a '0' has no effect.

Writing a '1' to this bit will clear the RAMPPDSU interrupt flag.

**Bit 3 – RAMCM4S** Interrupt Flag for RAMCM4S

This flag is set when an access error is detected by the RAMCM4S AHB slave, and will generate an interrupt request if INTENCLR/SET.ERR is '1'.

Writing a '0' has no effect.

Writing a '1' to this bit will clear the RAMCM4S interrupt flag.

**Bit 2 – NVMCTRL2** Interrupt Flag for NVMCTRL2

This flag is set when an access error is detected by the NVMCTRL2 AHB slave, and will generate an interrupt request if INTENCLR/SET.ERR is '1'.

Writing a '0' has no effect.

Writing a '1' to this bit will clear the NVMCTRL2 interrupt flag.

**Bit 1 – NVMCTRL1** Interrupt Flag for NVMCTRL1

This flag is set when an access error is detected by the NVMCTRL1 AHB slave, and will generate an interrupt request if INTENCLR/SET.ERR is '1'.

Writing a '0' has no effect.

Writing a '1' to this bit will clear the NVMCTRL1 interrupt flag.

**Bit 0 – NVMCTRL0** Interrupt Flag for NVMCTRL0

This flag is set when an access error is detected by the NVMCTRL0 AHB slave, and will generate an interrupt request if INTENCLR/SET.ERR is '1'.

Writing a '0' has no effect.

Writing a '1' to this bit will clear the NVMCTRL0 interrupt flag.

# SAM D5x/E5x Family Data Sheet

## PAC - Peripheral Access Controller

### 27.7.6 Peripheral Interrupt Flag Status - Bridge A

**Name:** INTFLAGA  
**Offset:** 0x14  
**Reset:** 0x00000000  
**Property:** –

These flags are set when a Peripheral Access Error occurs while accessing the peripheral associated with the respective INTFLAGx bit, and will generate an interrupt request if INTENCLR/SET.ERR is '1'.

Writing a '0' to these bits has no effect.

Writing a '1' to these bits will clear the corresponding INTFLAGx interrupt flag.

Bit	31	30	29	28	27	26	25	24
Access								
Reset								
Bit	23	22	21	20	19	18	17	16
Access								
Reset								
Bit	15	14	13	12	11	10	9	8
	TC1	TC0	SERCOM1	SERCOM0	FREQM	EIC	RTC	WDT
Access	RW	RW	RW	RW	RW	RW	RW	RW
Reset	0	0	0	0	0	0	0	0
Bit	7	6	5	4	3	2	1	0
	GCLK	SUPC	OSC32KCTRL	OSCCTRL	RSTC	MCLK	PM	PAC
Access	RW	RW	RW	RW	RW	RW	RW	RW
Reset	0	0	0	0	0	0	0	0

**Bit 15 – TC1** Interrupt Flag for TC1

This bit is set when a Peripheral Access Error occurs while accessing the TC1, and will generate an interrupt request if SET.ERR is '1'.

Writing a '0' to this bit has no effect.

Writing a '1' to this bit will clear the flag.

**Bit 14 – TC0** Interrupt Flag for TC0

This bit is set when a Peripheral Access Error occurs while accessing the TC0, and will generate an interrupt request if SET.ERR is '1'.

Writing a '0' to this bit has no effect.

Writing a '1' to this bit will clear the flag.

**Bit 13 – SERCOM1** Interrupt Flag for SERCOM1

This bit is set when a Peripheral Access Error occurs while accessing the SERCOM1, and will generate an interrupt request if SET.ERR is '1'.

Writing a '0' to this bit has no effect.

Writing a '1' to this bit will clear the flag.

**Bit 12 – SERCOM0** Interrupt Flag for SERCOM0

This bit is set when a Peripheral Access Error occurs while accessing the SERCOM0, and will generate an interrupt request if SET.ERR is '1'.

Writing a '0' to this bit has no effect.

Writing a '1' to this bit will clear the flag.

**Bit 11 – FREQM** Interrupt Flag for FREQM

This bit is set when a Peripheral Access Error occurs while accessing the FREQM, and will generate an interrupt request if SET.ERR is '1'.

Writing a '0' to this bit has no effect.

Writing a '1' to this bit will clear the flag.

**Bit 10 – EIC** Interrupt Flag for EIC

This bit is set when a Peripheral Access Error occurs while accessing the EIC, and will generate an interrupt request if SET.ERR is '1'.

Writing a '0' to this bit has no effect.

Writing a '1' to this bit will clear the flag.

**Bit 9 – RTC** Interrupt Flag for RTC

This bit is set when a Peripheral Access Error occurs while accessing the RTC, and will generate an interrupt request if SET.ERR is '1'.

Writing a '0' to this bit has no effect.

Writing a '1' to this bit will clear the flag.

**Bit 8 – WDT** Interrupt Flag for WDT

This bit is set when a Peripheral Access Error occurs while accessing the WDT, and will generate an interrupt request if SET.ERR is '1'.

Writing a '0' to this bit has no effect.

Writing a '1' to this bit will clear the flag.

**Bit 7 – GCLK** Interrupt Flag for GCLK

This bit is set when a Peripheral Access Error occurs while accessing the GCLK, and will generate an interrupt request if SET.ERR is '1'.

Writing a '0' to this bit has no effect.

Writing a '1' to this bit will clear the flag.

**Bit 6 – SUPC** Interrupt Flag for SUPC

This bit is set when a Peripheral Access Error occurs while accessing the SUPC, and will generate an interrupt request if SET.ERR is '1'.

Writing a '0' to this bit has no effect.

Writing a '1' to this bit will clear the flag.

**Bit 5 – OSC32KCTRL** Interrupt Flag for OSC32KCTRL

This bit is set when a Peripheral Access Error occurs while accessing the OSC32KCTRL, and will generate an interrupt request if SET.ERR is '1'.

Writing a '0' to this bit has no effect.

Writing a '1' to this bit will clear the flag.

**Bit 4 – OSCCTRL** Interrupt Flag for OSCCTRL

This bit is set when a Peripheral Access Error occurs while accessing the OSCCTRL, and will generate an interrupt request if SET.ERR is '1'.

Writing a '0' to this bit has no effect.

Writing a '1' to this bit will clear the flag.

**Bit 3 – RSTC** Interrupt Flag for RSTC

This bit is set when a Peripheral Access Error occurs while accessing the RSTC, and will generate an interrupt request if SET.ERR is '1'.

Writing a '0' to this bit has no effect.

Writing a '1' to this bit will clear the flag.

**Bit 2 – MCLK** Interrupt Flag for MCLK

This bit is set when a Peripheral Access Error occurs while accessing the MCLK, and will generate an interrupt request if SET.ERR is '1'.

Writing a '0' to this bit has no effect.

Writing a '1' to this bit will clear the flag.

**Bit 1 – PM** Interrupt Flag for PM

This bit is set when a Peripheral Access Error occurs while accessing the PM, and will generate an interrupt request if SET.ERR is '1'.

Writing a '0' to this bit has no effect.

Writing a '1' to this bit will clear the flag.

**Bit 0 – PAC** Interrupt Flag for PAC

This bit is set when a Peripheral Access Error occurs while accessing the PAC, and will generate an interrupt request if SET.ERR is '1'.

Writing a '0' to this bit has no effect.

Writing a '1' to this bit will clear the flag.

### 27.7.7 Peripheral Interrupt Flag Status - Bridge B

**Name:** INTFLAGB  
**Offset:** 0x18  
**Reset:** 0x00000000  
**Property:** –

These flags are set when a Peripheral Access Error occurs while accessing the peripheral associated with the respective INTFLAGx bit, and will generate an interrupt request if INTENCLR/SET.ERR is '1'.

Writing a '0' to these bits has no effect.

Writing a '1' to these bits will clear the corresponding INTFLAGx interrupt flag.

Bit	31	30	29	28	27	26	25	24
Access								
Reset								
Bit	23	22	21	20	19	18	17	16
								RAMECC
Access								RW
Reset								0
Bit	15	14	13	12	11	10	9	8
		TC3	TC2	TCC1	TCC0	SERCOM3	SERCOM2	
Access	RW		RW	RW	RW	RW	RW	
Reset	0		0	0	0	0	0	
Bit	7	6	5	4	3	2	1	0
	EVSYS		DMAC	PORT	CMCC	NVMCTRL	DSU	USB
Access	RW	RW		RW	RW	RW	RW	RW
Reset	0	0		0	0	0	0	0

**Bit 16 – RAMECC** Interrupt Flag for RAMECC

This flag is set when a Peripheral Access Error occurs while accessing the RAMECC, and will generate an interrupt request if INTENCLR/SET.ERR is '1'.

Writing a '0' to this bit has no effect.

Writing a '1' to this bit will clear the RAMECC interrupt flag.

**Bit 14 – TC3** Interrupt Flag for TC3

This flag is set when a Peripheral Access Error occurs while accessing the TC3, and will generate an interrupt request if INTENCLR/SET.ERR is '1'.

Writing a '0' to this bit has no effect.

Writing a '1' to this bit will clear the TC3 interrupt flag.

**Bit 13 – TC2** Interrupt Flag for TC2

This flag is set when a Peripheral Access Error occurs while accessing the TC2, and will generate an interrupt request if INTENCLR/SET.ERR is '1'.

Writing a '0' to this bit has no effect.

Writing a '1' to this bit will clear the TC2 interrupt flag.

**Bit 12 – TCC1** Interrupt Flag for TCC1

This flag is set when a Peripheral Access Error occurs while accessing the TCC1, and will generate an interrupt request if INTENCLR/SET.ERR is '1'.

Writing a '0' to this bit has no effect.

Writing a '1' to this bit will clear the TCC1 interrupt flag.

**Bit 11 – TCC0** Interrupt Flag for TCC0

This flag is set when a Peripheral Access Error occurs while accessing the TCC0, and will generate an interrupt request if INTENCLR/SET.ERR is '1'.

Writing a '0' to this bit has no effect.

Writing a '1' to this bit will clear the TCC0 interrupt flag.

**Bit 10 – SERCOM3** Interrupt Flag for SERCOM3

This flag is set when a Peripheral Access Error occurs while accessing the SERCOM3, and will generate an interrupt request if INTENCLR/SET.ERR is '1'.

Writing a '0' to this bit has no effect.

Writing a '1' to this bit will clear the SERCOM3 interrupt flag.

**Bit 9 – SERCOM2** Interrupt Flag for SERCOM2

This flag is set when a Peripheral Access Error occurs while accessing the SERCOM2, and will generate an interrupt request if INTENCLR/SET.ERR is '1'.

Writing a '0' to this bit has no effect.

Writing a '1' to this bit will clear the SERCOM2 interrupt flag.

**Bit 7 – EVSYS** Interrupt Flag for EVSYS

This flag is set when a Peripheral Access Error occurs while accessing the EVSYS, and will generate an interrupt request if INTENCLR/SET.ERR is '1'.

Writing a '0' to this bit has no effect.

Writing a '1' to this bit will clear the EVSYS interrupt flag.

**Bit 5 – DMAC** Interrupt Flag for DMAC

This flag is set when a Peripheral Access Error occurs while accessing the DMAC, and will generate an interrupt request if INTENCLR/SET.ERR is '1'.

Writing a '0' to this bit has no effect.

Writing a '1' to this bit will clear the DMAC interrupt flag.

**Bit 4 – PORT** Interrupt Flag for PORT

This flag is set when a Peripheral Access Error occurs while accessing the PORT, and will generate an interrupt request if INTENCLR/SET.ERR is '1'.

Writing a '0' to this bit has no effect.

Writing a '1' to this bit will clear the PORT interrupt flag.

**Bit 3 – CMCC** Interrupt Flag for CMCC

This flag is set when a Peripheral Access Error occurs while accessing the CMCC, and will generate an interrupt request if INTENCLR/SET.ERR is '1'.

Writing a '0' to this bit has no effect.

Writing a '1' to this bit will clear the CMCC interrupt flag.



**Bit 2 – NVMCTRL** Interrupt Flag for NVMCTRL

This flag is set when a Peripheral Access Error occurs while accessing the NVMCTRL, and will generate an interrupt request if INTENCLR/SET.ERR is '1'.

Writing a '0' to this bit has no effect.

Writing a '1' to this bit will clear the NVMCTRL interrupt flag.

**Bit 1 – DSU** Interrupt Flag for DSU

This flag is set when a Peripheral Access Error occurs while accessing the DSU, and will generate an interrupt request if INTENCLR/SET.ERR is '1'.

Writing a '0' to this bit has no effect.

Writing a '1' to this bit will clear the DSU interrupt flag.

**Bit 0 – USB** Interrupt Flag for USB

This flag is set when a Peripheral Access Error occurs while accessing the USB, and will generate an interrupt request if INTENCLR/SET.ERR is '1'.

Writing a '0' to this bit has no effect.

Writing a '1' to this bit will clear the USB interrupt flag.

### 27.7.8 Peripheral Interrupt Flag Status - Bridge C

**Name:** INTFLAGC  
**Offset:** 0x1C  
**Reset:** 0x00000000  
**Property:** –

These flags are set when a Peripheral Access Error occurs while accessing the peripheral associated with the respective INTFLAGx bit, and will generate an interrupt request if INTENCLR/SET.ERR is '1'.

Writing a '0' to these bits has no effect.

Writing a '1' to these bits will clear the corresponding INTFLAGx interrupt flag.

Bit	31	30	29	28	27	26	25	24	
Access									
Reset									
Bit	23	22	21	20	19	18	17	16	
Access									
Reset									
Bit	15	14	13	12	11	10	9	8	
			CCL	QSPI	PUKCC	ICM	TRNG	AES	
Access			RW	RW	RW	RW	RW	RW	
Reset			0	0	0	0	0	0	
Bit	7	6	5	4	3	2	1	0	
	PDEC	TC5	TC4	TCC3	TCC2	GMAC	CAN1	CAN0	
Access	RW	RW	RW	RW	RW	RW	RW	RW	
Reset	0	0	0	0	0	0	0	0	

**Bit 14 – CCL** Interrupt Flag for CCL

This flag is set when a Peripheral Access Error occurs while accessing the peripheral associated with the CCL, and will generate an interrupt request if INTENCLR/SET.ERR is '1'.

Writing a '0' to this bit has no effect.

Writing a '1' to this bit will clear the CCL interrupt flag.

**Bit 13 – QSPI** Interrupt Flag for QSPI

This flag is set when a Peripheral Access Error occurs while accessing the peripheral associated with the QSPI, and will generate an interrupt request if INTENCLR/SET.ERR is '1'.

Writing a '0' to this bit has no effect.

Writing a '1' to this bit will clear the QSPI interrupt flag.

**Bit 12 – PUKCC** Interrupt Flag for PUKCC

This flag is set when a Peripheral Access Error occurs while accessing the peripheral associated with the PUKCC, and will generate an interrupt request if INTENCLR/SET.ERR is '1'.

Writing a '0' to this bit has no effect.

Writing a '1' to this bit will clear the PUKCC interrupt flag.

**Bit 11 – ICM** Interrupt Flag for ICM

This flag is set when a Peripheral Access Error occurs while accessing the peripheral associated with the ICM, and will generate an interrupt request if INTENCLR/SET.ERR is '1'.

Writing a '0' to this bit has no effect.

Writing a '1' to this bit will clear the ICM interrupt flag.

**Bit 10 – TRNG** Interrupt Flag for TRNG

This flag is set when a Peripheral Access Error occurs while accessing the peripheral associated with the TRNG, and will generate an interrupt request if INTENCLR/SET.ERR is '1'.

Writing a '0' to this bit has no effect.

Writing a '1' to this bit will clear the TRNG interrupt flag.

**Bit 9 – AES** Interrupt Flag for AES

This flag is set when a Peripheral Access Error occurs while accessing the peripheral associated with the AES, and will generate an interrupt request if INTENCLR/SET.ERR is '1'.

Writing a '0' to this bit has no effect.

Writing a '1' to this bit will clear the AES interrupt flag.

**Bit 7 – PDEC** Interrupt Flag for PDEC

This flag is set when a Peripheral Access Error occurs while accessing the peripheral associated with the PDEC, and will generate an interrupt request if INTENCLR/SET.ERR is '1'.

Writing a '0' to this bit has no effect.

Writing a '1' to this bit will clear the PDEC interrupt flag.

**Bit 6 – TC5** Interrupt Flag for TC5

This flag is set when a Peripheral Access Error occurs while accessing the peripheral associated with the TC5, and will generate an interrupt request if INTENCLR/SET.ERR is '1'.

Writing a '0' to this bit has no effect.

Writing a '1' to this bit will clear the TC5 interrupt flag.

**Bit 5 – TC4** Interrupt Flag for TC4

This flag is set when a Peripheral Access Error occurs while accessing the peripheral associated with the TC4, and will generate an interrupt request if INTENCLR/SET.ERR is '1'.

Writing a '0' to this bit has no effect.

Writing a '1' to this bit will clear the TC4 interrupt flag.

**Bit 4 – TCC3** Interrupt Flag for TCC3

This flag is set when a Peripheral Access Error occurs while accessing the peripheral associated with the TCC3, and will generate an interrupt request if INTENCLR/SET.ERR is '1'.

Writing a '0' to this bit has no effect.

Writing a '1' to this bit will clear the TCC3 interrupt flag.

**Bit 3 – TCC2** Interrupt Flag for TCC2

This flag is set when a Peripheral Access Error occurs while accessing the peripheral associated with the TCC2, and will generate an interrupt request if INTENCLR/SET.ERR is '1'.

Writing a '0' to this bit has no effect.

Writing a '1' to this bit will clear the TCC2 interrupt flag.

**Bit 2 – GMAC** Interrupt Flag for GMAC

This flag is set when a Peripheral Access Error occurs while accessing the peripheral associated with the GMAC, and will generate an interrupt request if INTENCLR/SET.ERR is '1'.

Writing a '0' to this bit has no effect.

Writing a '1' to this bit will clear the GMAC interrupt flag.

**Bit 1 – CAN1** Interrupt Flag for CAN1

This flag is set when a Peripheral Access Error occurs while accessing the peripheral associated with the CAN1, and will generate an interrupt request if INTENCLR/SET.ERR is '1'.

Writing a '0' to this bit has no effect.

Writing a '1' to this bit will clear the CAN1 interrupt flag.

**Bit 0 – CAN0** Interrupt Flag for CAN0

This flag is set when a Peripheral Access Error occurs while accessing the peripheral associated with the CAN0, and will generate an interrupt request if INTENCLR/SET.ERR is '1'.

Writing a '0' to this bit has no effect.

Writing a '1' to this bit will clear the CAN0 interrupt flag.

### 27.7.9 Peripheral Interrupt Flag Status - Bridge D

**Name:** INTFLAGD  
**Offset:** 0x20  
**Reset:** 0x00000000  
**Property:** –

These flags are set when a Peripheral Access Error occurs while accessing the peripheral associated with the respective INTFLAGx bit, and will generate an interrupt request if INTENCLR/SET.ERR is '1'.

Writing a '0' to these bits has no effect.

Writing a '1' to these bits will clear the corresponding INTFLAGx interrupt flag.

Bit	31	30	29	28	27	26	25	24
Access								
Reset								
Bit	23	22	21	20	19	18	17	16
Access								
Reset								
Bit	15	14	13	12	11	10	9	8
					PCC	I2S	DAC	ADC1
Access					RW	RW	RW	RW
Reset					0	0	0	0
Bit	7	6	5	4	3	2	1	0
	ADC0	TC7	TC6	TCC4	SERCOM7	SERCOM6	SERCOM5	SERCOM4
Access	RW	RW	RW	RW	RW	RW	RW	RW
Reset	0	0	0	0	0	0	0	0

**Bit 11 – PCC** Interrupt Flag for PCC

This flag is set when a Peripheral Access Error occurs while accessing the PCC, and will generate an interrupt request if INTENCLR/SET.ERR is '1'.

Writing a '0' to these bits has no effect.

Writing a '1' to these bits will clear the PCC interrupt flag.

**Bit 10 – I2S** Interrupt Flag for I2S

This flag is set when a Peripheral Access Error occurs while accessing the I2S, and will generate an interrupt request if INTENCLR/SET.ERR is '1'.

Writing a '0' to these bits has no effect.

Writing a '1' to these bits will clear the I2S interrupt flag.

**Bit 9 – DAC** Interrupt Flag for DAC

This flag is set when a Peripheral Access Error occurs while accessing the DAC, and will generate an interrupt request if INTENCLR/SET.ERR is '1'.

Writing a '0' to these bits has no effect.

Writing a '1' to these bits will clear the DAC interrupt flag.

**Bit 8 – ADC1** Interrupt Flag for ADC1

This flag is set when a Peripheral Access Error occurs while accessing the ADC1, and will generate an interrupt request if INTENCLR/SET.ERR is '1'.

Writing a '0' to these bits has no effect.

Writing a '1' to these bits will clear the ADC1 interrupt flag.

**Bit 7 – ADC0** Interrupt Flag for ADC0

This flag is set when a Peripheral Access Error occurs while accessing the ADC0, and will generate an interrupt request if INTENCLR/SET.ERR is '1'.

Writing a '0' to these bits has no effect.

Writing a '1' to these bits will clear the ADC0 interrupt flag.

**Bit 6 – TC7** Interrupt Flag for TC7

This flag is set when a Peripheral Access Error occurs while accessing the TC6, and will generate an interrupt request if INTENCLR/SET.ERR is '1'.

Writing a '0' to these bits has no effect.

Writing a '1' to these bits will clear the TC7 interrupt flag.

**Bit 5 – TC6** Interrupt Flag for TC6

This flag is set when a Peripheral Access Error occurs while accessing the TC6, and will generate an interrupt request if INTENCLR/SET.ERR is '1'.

Writing a '0' to these bits has no effect.

Writing a '1' to these bits will clear the TC6 interrupt flag.

**Bit 4 – TCC4** Interrupt Flag for TCC4

This flag is set when a Peripheral Access Error occurs while accessing the TCC4, and will generate an interrupt request if INTENCLR/SET.ERR is '1'.

Writing a '0' to these bits has no effect.

Writing a '1' to these bits will clear the TCC4 interrupt flag.

**Bit 3 – SERCOM7** Interrupt Flag for SERCOM7

This flag is set when a Peripheral Access Error occurs while accessing the SERCOM7, and will generate an interrupt request if INTENCLR/SET.ERR is '1'.

Writing a '0' to these bits has no effect.

Writing a '1' to these bits will clear the SERCOM7 interrupt flag.

**Bit 2 – SERCOM6** Interrupt Flag for SERCOM6

This flag is set when a Peripheral Access Error occurs while accessing the SERCOM6, and will generate an interrupt request if INTENCLR/SET.ERR is '1'.

Writing a '0' to these bits has no effect.

Writing a '1' to these bits will clear the SERCOM6 interrupt flag.

**Bit 1 – SERCOM5** Interrupt Flag for SERCOM5

This flag is set when a Peripheral Access Error occurs while accessing the SERCOM5, and will generate an interrupt request if INTENCLR/SET.ERR is '1'.

Writing a '0' to these bits has no effect.

Writing a '1' to these bits will clear the SERCOM5 interrupt flag.

# SAM D5x/E5x Family Data Sheet

## PAC - Peripheral Access Controller

---

---

### **Bit 0 – SERCOM4** Interrupt Flag for SERCOM4

This flag is set when a Peripheral Access Error occurs while accessing the SERCOM4, and will generate an interrupt request if INTENCLR/SET.ERR is '1'.

Writing a '0' to these bits has no effect.

Writing a '1' to these bits will clear the SERCOM4 interrupt flag.

# SAM D5x/E5x Family Data Sheet

## PAC - Peripheral Access Controller

### 27.7.10 Peripheral Write Protection Status A

**Name:** STATUSA  
**Offset:** 0x34  
**Reset:** 0x00010000  
**Property:** PAC Write-Protection

Writing to this register has no effect.

Reading STATUS register returns peripheral write protection status:

Value	Description
0	Peripheral is not write protected.
1	Peripheral is write protected.

Bit	31	30	29	28	27	26	25	24
Access								
Reset								
Bit	23	22	21	20	19	18	17	16
Access								
Reset								
Bit	15	14	13	12	11	10	9	8
Access	R	R	R	R	R	R		R
Reset	0	0	0	0	0	0		0
Bit	7	6	5	4	3	2	1	0
Access	R	R	R	R	R	R	R	R
Reset	0	0	0	0	0	0	0	0

#### Bit 15 – TC1 TC1 APB Protect Enable

Value	Description
0	TC1 is not write protected
1	TC1 is write protected

#### Bit 14 – TC0 TC0 APB Protect Enable

Value	Description
0	TC0 is not write protected
1	TC0 is write protected

#### Bit 13 – SERCOM1 SERCOM1 APB Protect Enable

Value	Description
0	SERCOM1 is not write protected
1	SERCOM1 is write protected



# SAM D5x/E5x Family Data Sheet

## PAC - Peripheral Access Controller

### Bit 12 – SERCOM0 SERCOM0 APB Protect Enable

Value	Description
0	SERCOM0 is not write protected
1	SERCOM0 is write protected

### Bit 11 – FREQM FREQM APB Protect Enable

Value	Description
0	FREQM is not write protected
1	FREQM is write protected

### Bit 10 – EIC EIC APB Protect Enable

Value	Description
0	EIC is not write protected
1	EIC is write protected

### Bit 8 – WDT WDT APB Protect Enable

Value	Description
0	WDT is not write protected
1	WDT is write protected

### Bit 7 – GCLK GCLK APB Protect Enable

Value	Description
0	GCLK is not write protected
1	GCLK is write protected

### Bit 6 – SUPC SUPC APB Protect Enable

Value	Description
0	SUPC is not write protected
1	SUPC is write protected

### Bit 5 – OSC32KCTRL OSC32KCTRL APB Protect Enable

Value	Description
0	OSC32KCTRL is not write protected
1	OSC32KCTRL is write protected

### Bit 4 – OSCCTRL OSCCTRL APB Protect Enable

Value	Description
0	OSCCTRL is not write protected
1	OSCCTRL is write protected

### Bit 3 – RSTC RSTC APB Protect Enable

Value	Description
0	RSTC is not write protected
1	RSTC is write protected

### Bit 2 – MCLK MCLK APB Protect Enable

Value	Description
0	MCLK is not write protected
1	MCLK is write protected

# SAM D5x/E5x Family Data Sheet

## PAC - Peripheral Access Controller

---

---

**Bit 1 – PM** PM APB Protect Enable

Value	Description
0	PM is not write protected
1	PM is write protected

**Bit 0 – PAC** PAC APB Protect Enable

Value	Description
0	PAC is not write protected
1	PAC is write protected

# SAM D5x/E5x Family Data Sheet

## PAC - Peripheral Access Controller

### 27.7.11 Peripheral Write Protection Status - Bridge B

**Name:** STATUSB  
**Offset:** 0x38  
**Reset:** 0x00000002  
**Property:** PAC Write-Protection

Writing to this register has no effect.

Reading STATUS register returns peripheral write protection status:

Value	Description
0	Peripheral is not write protected.
1	Peripheral is write protected.

Bit	31	30	29	28	27	26	25	24
Access								
Reset								
Bit	23	22	21	20	19	18	17	16
Access								RAMECC
Reset								0
Bit	15	14	13	12	11	10	9	8
Access		TC3	TC2	TCC1	TCC0	SERCOM3	SERCOM2	
Reset		0	0	0	0	0	0	
Bit	7	6	5	4	3	2	1	0
Access	EVSYS		DMAC	PORT	CMCC	NVMCTRL	DSU	USB
Reset	0		0	0	0	0	1	0

#### Bit 16 – RAMECC RAMECC APB Protect Enable

Value	Description
0	RAMECC peripheral is not write protected
1	RAMECC peripheral is write protected

#### Bit 14 – TC3 TC3 APB Protect Enable

Value	Description
0	TC3 peripheral is not write protected
1	TC3 peripheral is write protected

#### Bit 13 – TC2 TC2 APB Protect Enable

Value	Description
0	TC2 peripheral is not write protected
1	TC2 peripheral is write protected

**Bit 12 – TCC1** TCC1 APB Protect Enable

Value	Description
0	TCC1 peripheral is not write protected
1	TCC1 peripheral is write protected

**Bit 11 – TCC0** TCC0 APB Protect Enable

Value	Description
0	TCC0 peripheral is not write protected
1	TCC0 peripheral is write protected

**Bit 10 – SERCOM3** SERCOM3 APB Protect Enable

Value	Description
0	SERCOM3 peripheral is not write protected
1	SERCOM3 peripheral is write protected

**Bit 9 – SERCOM2** SERCOM2 APB Protect Enable

Value	Description
0	SERCOM2 peripheral is not write protected
1	SERCOM2 peripheral is write protected

**Bit 7 – EVSYS** EVSYS APB Protect Enable

Value	Description
0	EVSYS peripheral is not write protected
1	EVSYS peripheral is write protected

**Bit 5 – DMAC** DMAC APB Protect Enable

Value	Description
0	DMAC peripheral is not write protected
1	DMAC peripheral is write protected

**Bit 4 – PORT** PORT APB Protect Enable

Value	Description
0	PORT peripheral is not write protected
1	PORT peripheral is write protected

**Bit 3 – CMCC** CMCC APB Protect Enable

Value	Description
0	CMCC peripheral is not write protected
1	CMCC peripheral is write protected

**Bit 2 – NVMCTRL** NVMCTRL APB Protect Enable

Value	Description
0	NVMCTRL peripheral is not write protected
1	NVMCTRL peripheral is write protected

**Bit 1 – DSU** DSU APB Protect Enable

Value	Description
0	DSU peripheral is not write protected
1	DSU peripheral is write protected

# SAM D5x/E5x Family Data Sheet

## PAC - Peripheral Access Controller

---

---

**Bit 0 – USB** USB APB Protect Enable

Value	Description
0	USB peripheral is not write protected
1	USB peripheral is write protected

# SAM D5x/E5x Family Data Sheet

## PAC - Peripheral Access Controller

### 27.7.12 Peripheral Write Protection Status - Bridge C

**Name:** STATUSC  
**Offset:** 0x3C  
**Reset:** 0x00000000  
**Property:** PAC Write-Protection

Writing to this register has no effect.

Reading STATUS register returns peripheral write protection status:

Value	Description
0	Peripheral is not write protected.
1	Peripheral is write protected.

Bit	31	30	29	28	27	26	25	24
Access								
Reset								
Bit	23	22	21	20	19	18	17	16
Access								
Reset								
Bit	15	14	13	12	11	10	9	8
Access		R	R	R	R	R	R	R
Reset		0	0	0	0	0	0	0
Bit	7	6	5	4	3	2	1	0
Access	R	R	R	R	R	R	R	R
Reset	0	0	0	0	0	0	0	0

#### Bit 14 – CCL CCL APB Protection Enable

Value	Description
0	Peripheral is not write protected
1	Peripheral is write protected

#### Bit 13 – QSPI QSPI APB Protection Enable

Value	Description
0	Peripheral is not write protected
1	Peripheral is write protected

#### Bit 12 – PUKCC PUKCC APB Protection Enable

Value	Description
0	Peripheral is not write protected
1	Peripheral is write protected

# SAM D5x/E5x Family Data Sheet

## PAC - Peripheral Access Controller

### Bit 11 – ICM ICM APB Protection Enable

Value	Description
0	Peripheral is not write protected
1	Peripheral is write protected

### Bit 10 – TRNG TRNG APB Protection Enable

Value	Description
0	Peripheral is not write protected
1	Peripheral is write protected

### Bit 9 – AES AES APB Protection Enable

Value	Description
0	Peripheral is not write protected
1	Peripheral is write protected

### Bit 8 – AC AC APB Protection Enable

Value	Description
0	Peripheral is not write protected
1	Peripheral is write protected

### Bit 7 – PDEC PDEC APB Protection Enable

Value	Description
0	Peripheral is not write protected
1	Peripheral is write protected

### Bit 6 – TC5 TC5 APB Protection Enable

Value	Description
0	Peripheral is not write protected
1	Peripheral is write protected

### Bit 5 – TC4 TC4 APB Protection Enable

Value	Description
0	Peripheral is not write protected
1	Peripheral is write protected

### Bit 4 – TCC3 TCC3 APB Protection Enable

Value	Description
0	Peripheral is not write protected
1	Peripheral is write protected

### Bit 3 – TCC2 TCC2 APB Protection Enable

Value	Description
0	Peripheral is not write protected
1	Peripheral is write protected

### Bit 2 – GMAC GMAC APB Protection Enable

Value	Description
0	Peripheral is not write protected
1	Peripheral is write protected

# SAM D5x/E5x Family Data Sheet

## PAC - Peripheral Access Controller

---

---

**Bit 1 – CAN1** CAN1 APB Protection Enable

Value	Description
0	Peripheral is not write protected
1	Peripheral is write protected

**Bit 0 – CAN0** CAN0 APB Protection Enable

Value	Description
0	Peripheral is not write protected
1	Peripheral is write protected



# SAM D5x/E5x Family Data Sheet

## PAC - Peripheral Access Controller

### 27.7.13 Peripheral Write Protection Status - Bridge D

**Name:** STATUSD  
**Offset:** 0x40  
**Reset:** 0x00000000  
**Property:** PAC Write-Protection, Read-Only

Writing to this register has no effect.

Reading STATUS register returns peripheral write protection status:

Value	Description
0	Peripheral is not write protected.
1	Peripheral is write protected.

Bit	31	30	29	28	27	26	25	24
Access								
Reset								
Bit	23	22	21	20	19	18	17	16
Access								
Reset								
Bit	15	14	13	12	11	10	9	8
Access					R	R	R	R
Reset					0	0	0	0
Bit	7	6	5	4	3	2	1	0
Access	R	R	R	R	R	R	R	R
Reset	0	0	0	0	0	0	0	0

#### Bit 11 – PCC PCC APB Protect Enable

Value	Description
0	PCC is not write protected
1	PCC is write protected

#### Bit 10 – I2S I2S APB Protect Enable

Value	Description
0	I2S is not write protected
1	I2S is write protected

#### Bit 9 – DAC DAC APB Protect Enable

Value	Description
0	DAC is not write protected
1	DAC is write protected

# SAM D5x/E5x Family Data Sheet

## PAC - Peripheral Access Controller

### Bit 8 – ADC1 ADC1 APB Protect Enable

Value	Description
0	ADC1 is not write protected
1	ADC1 is write protected

### Bit 7 – ADC0 ADC0 APB Protect Enable

Value	Description
0	ADC0 is not write protected
1	ADC0 is write protected

### Bit 6 – TC7 TC7 APB Protect Enable

Value	Description
0	TC7 is not write protected
1	TC7 is write protected

### Bit 5 – TC6 TC6 APB Protect Enable

Value	Description
0	TC6 is not write protected
1	TC6 is write protected

### Bit 4 – TCC4 TCC4 APB Protect Enable

Value	Description
0	TCC4 is not write protected
1	TCC4 is write protected

### Bit 3 – SERCOM7 SERCOM7 APB Protect Enable

Value	Description
0	SERCOM7 is not write protected
1	SERCOM7 is write protected

### Bit 2 – SERCOM6 SERCOM6 APB Protect Enable

Value	Description
0	SERCOM6 is not write protected
1	SERCOM6 is write protected

### Bit 1 – SERCOM5 SERCOM5 APB Protect Enable

Value	Description
0	SERCOM5 is not write protected
1	SERCOM5 is write protected

### Bit 0 – SERCOM4 SERCOM4 APB Protect Enable

Value	Description
0	SERCOM4 is not write protected
1	SERCOM4 is write protected

## **28. OSCCTRL – Oscillators Controller**

### **28.1 Overview**

The Oscillators Controller (OSCCTRL) provides a user interface to the XOSCn, DFLL48M, and two FDPPLL200M.

Through the interface registers, it is possible to enable, disable, calibrate, and monitor the oscillators.

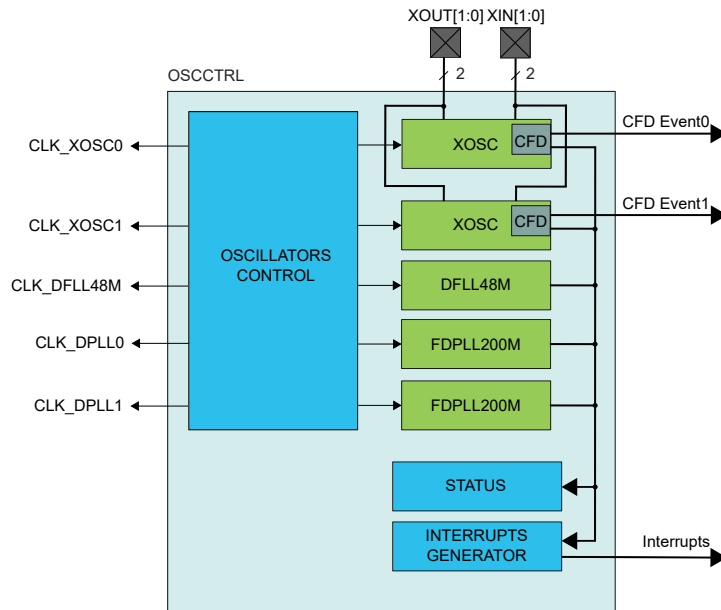
The status of all oscillators are collected in the Status register (STATUS). They can additionally trigger interrupts upon status changes via the INTENSET, INTENCLR, and INTFLAG registers.

### **28.2 Features**

- Digital Frequency-Locked Loop (DFLL48M)
  - Internal oscillator with no external components
  - 48 MHz output frequency
  - Operates stand-alone as a high-frequency programmable oscillator in Open Loop mode
  - Operates as an accurate frequency multiplier against a known frequency in Closed Loop mode
- Two 8-48 MHz Crystal Oscillators (XOSCn)
  - Tunable gain control
  - Programmable start-up time
  - Crystal or external input clock on XIN I/O
  - Clock failure detection with safe clock switch
  - Clock failure event output
- Two Digital Phase-Locked Loop (DPLLn)
  - 96 MHz to 200 MHz output frequency from a 32 kHz to 3.2 MHz reference clock
  - Two DPLLs, each with four selectable reference clocks
  - Adjustable digital filter for jitter optimization
  - Adjustable DCO filter for a 4-stages differential ring oscillator
  - Fractional part used to achieve 1/32th of reference clock step
  - Embedded test mode controller

### 28.3 Block Diagram

Figure 28-1. OSCCTRL Block Diagram



### 28.4 Signal Description

Signal	Description	Type
XIN[1:0]	Multipurpose Crystal Oscillator or external clock generator input	Analog input
XOUT[1:0]	Multipurpose Crystal Oscillator output	Analog output

The I/O lines are automatically selected when XOSCn is enabled.

### 28.5 Product Dependencies

In order to use this peripheral, other parts of the system must be configured correctly, as described below.

#### 28.5.1 I/O Lines

I/O lines are configured by OSCCTRL when XOSCn is enabled, and need no user configuration.

#### 28.5.2 Power Management

The OSCCTRL can continue to operate in any sleep mode where the selected source clock is running. The OSCCTRL interrupts can be used to wake up the device from sleep modes. The events can trigger other operations in the system without exiting sleep modes.

#### Related Links

[18. PM – Power Manager](#)

#### 28.5.3 Clocks

The OSCCTRL gathers controls for all device oscillators and provides clock sources to the Generic Clock Controller (GCLK). The available clock sources are: XOSCn, DFLL48M, and FDPLL200Mn.

The DFLL48M requires a reference clock (GCLK\_DFLL48M\_REF) from the GCLK. The control logic uses the oscillator output, which is also asynchronous to the user interface clock (CLK\_OSCCTRL\_APB). Due to this asynchronicity, writes to certain registers will require synchronization between the clock domains. Refer to Synchronization for further details.

The FDPLL200Mn require a reference clock (GCLK\_DPLL) for the FDPLL output. When the optional lock timer timeout function is used, a 32KHz reference clock (GCLK\_DPLL\_32K) is also required. Both reference clocks can either stem from the GCLK and/or from external oscillators.

### 28.5.4 DMA

Not applicable.

### 28.5.5 Interrupts

The interrupt request line is connected to the Interrupt Controller. Using the OSCCTRL interrupts requires the interrupt controller to be configured first.

#### Related Links

[10.2 Nested Vector Interrupt Controller](#)

### 28.5.6 Events

The events of this peripheral are connected to the Event System.

#### Related Links

[31. EVSYS – Event System](#)

### 28.5.7 Debug Operation

When the CPU is halted in debug mode the OSCCTRL continues normal operation. If the OSCCTRL is configured in a way that requires it to be periodically serviced by the CPU through interrupts or similar, improper operation or data loss may result during debugging.

### 28.5.8 Register Access Protection

All registers with write access can be write-protected optionally by the Peripheral Access Controller (PAC), except for the following registers:

- Interrupt Flag Status and Clear register (INTFLAG)

**Note:** Optional write protection is indicated by the "PAC Write Protection" property in the register description.

Write protection does not apply for accesses through an external debugger.

### 28.5.9 Analog Connections

The 8-48 MHz crystal must be connected between the XIN and XOUT pins, along with any required load capacitors.

**Note:** Refer to the Electrical Characteristics for more information about load capacitors.

## 28.6 Functional Description

### 28.6.1 Principle of Operation

XOSC, DFLL48M, and DPLL200M are configured via OSCCTRL control registers. Through this interface, the oscillators are enabled, disabled, or have their calibration values updated.

# SAM D5x/E5x Family Data Sheet

## OSCCTRL – Oscillators Controller

The Status register gathers different status signals coming from the oscillators controlled by the OSCCTRL. The status signals can be used to generate system interrupts, and in some cases wake up the system from Sleep mode, provided the corresponding interrupt is enabled.

### 28.6.2 External Multipurpose Crystal Oscillator (XOSCn) Operation

The XOSCn can operate in two different modes:

- External clock, with an external clock signal connected to the XIN pin
- Crystal oscillator, with an external 8-48 MHz crystal

The XOSCn can be used as a clock source for generic clock generators. This is configured by the Generic Clock Controller.

At reset, the XOSCn is disabled, and the XINn/XOUTn pins can be used as General Purpose I/O (GPIO) pins or by other peripherals in the system. When XOSCn is enabled, the operating mode determines the GPIO usage. When in crystal oscillator mode, the XINn and XOUTn pins are controlled by the OSCCTRL, and GPIO functions are overridden on both pins. When in external clock mode, only the XINn pins will be overridden and controlled by the OSCCTRL, while the XOUTn pins can still be used as GPIO pins.

The XOSCn is enabled by writing a '1' to the Enable bit in the External Multipurpose Crystal Oscillator Control register (XOSCCTRLn.ENABLE). To enable XOSCn as an external crystal oscillator, the XTAL Enable bit (XOSCCTRLn.XTALEN) must be written to '1'. If XOSCCTRLn.XTALEN is zero, the external clock input on XIN will be enabled.

When in crystal oscillator mode (XOSCCTRLn.XTALEN=1), the External Multipurpose Crystal Oscillator Current Control (XOSCCTRLn.IPTAT, XOSCCTRLn.IMULT) must be set to match the external crystal oscillator frequency. If the External Multipurpose Crystal Oscillator Enable Amplitude Loop Control (XOSCCTRLn.ENALC) is '1', the oscillator amplitude will be automatically adjusted, and in most cases result in lower power consumption.

The bias current of the Crystal Oscillator can be adjusted to the desired value for a proper oscillation by setting the bit fields XOSCCTRLn.IPTAT and XOSCCTRLn.IMULT. See the recommended setting in [Table 28-7](#).

The low buffer gain is used to adjust the oscillator's amplitude in automatic loop control (XOSCCTRLn.ENALC=1). The default value of LOWBUFFGAIN=0 should be used to allow operating with a low amplitude oscillator. The setting LOWBUFFGAIN=1 can be used to solve stability issues. If set, the oscillator's amplitude is increased by a factor of approximately 2.

The XOSCn will behave differently in different sleep modes, based on the settings of XOSCCTRLn.RUNSTDBY, XOSCCTRLn.ONDEMAND, and XOSCCTRLn.ENABLE

**Table 28-1. XOSC Sleep Behavior**

XOSCCTRLn.RUNS TDBY	XOSCCTRLn.ONDE MAND	XOSCCTRLn.ENABLE	Sleep Behavior
-	-	0	Disabled
0	0	1	Always run in Idle Sleep modes. Run in Standby Sleep mode if requested by a peripheral.
0	1	1	Only run in Idle or Standby Sleep modes if requested by a peripheral.

.....continued			
XOSCCTRLn.RUNS TDBY	XOSCCTRLn.ONDE MAND	XOSCCTRLn.ENABL E	Sleep Behavior
1	0	1	Always run in Idle and Standby Sleep modes.
1	1	1	Only run in Idle or Standby Sleep modes if requested by a peripheral.

After a hard reset, or when waking up from a sleep mode where the XOSCn was disabled, the XOSCn will need a certain amount of time to stabilize on the correct frequency. This start-up time can be configured by changing the Oscillator Start-Up Time bit group (XOSCCTRLn.STARTUP) in the External Multipurpose Crystal Oscillator Control register. During the start-up time, the oscillator output is masked to ensure that no unstable clock propagates to the digital logic. The External Multipurpose Crystal Oscillator Ready bit in the Status register (STATUS.XOSCRDYn) is set when the external clock or crystal oscillator is stable and ready to be used as a clock source. An interrupt is generated on a zero-to-one transition on STATUS.XOSCRDYn if the External Multipurpose Crystal Oscillator Ready bit in the Interrupt Enable Set register (INTENSET.XOSCRDYn) is set.

### Related Links

[14. GCLK - Generic Clock Controller](#)

### 28.6.3 Clock Failure Detection Operation

The Clock Failure Detector (CFD) allows the user to monitor the external clock or crystal oscillator clock signal provided by the External Multipurpose Crystal Oscillator (XOSCn). It detects failing operation of the XOSCn clock, and allows to switch to a safe clock in case of clock failure. The user can also switch from the safe clock to the XOSCn clock in case of clock recovery. The safe clock is derived from the DFLL48M with a configurable prescaler. This allows to configure the safe clock in order to fulfill the operative conditions of the microcontroller. The CFD operation is automatically suspended when the XOSCn clock is not requested in ONDEMAND mode or halted in STANDBY.

The user interface registers allow to enable, disable and configure the CFD. The Status register gives status on failure and clock switch conditions. The Clock Failure Detector can optionally trigger an interrupt or an event when a failure is detected.

#### Clock Failure Detection

At reset, the CFD is disabled. The CFD does not monitor the XOSCn clock when the oscillator is disabled (XOSCCTRLn.ENABLE = 0).

Before starting the CFD operation, the user must start and enable the safe clock source (DFLL48M). To start the CFD operation, the user must write a one to the CFD Enable bit in the External Oscillator Control register (XOSCCTRLn.CFDEN). After the start or restart of the XOSCn, the CFD does not detect failure until the start-up time, as configured by the Oscillator Start-Up Time (XOSCCTRLn.STARTUP) in the External Multipurpose Crystal Oscillator Control register, is elapsed. Once the XOSCn Start-Up Time is elapsed, the XOSCn clock is constantly monitored.

During a period of 4 safe clocks, the CFD watches for a clock activity from the XOSCn. There must be one rising and one falling XOSCn clock edges during a 4 safe clock periods to meet a non failure status. If no activity is detected, the failure status is asserted. The Clock Failure status bit in the Status register (STATUS.CLKFAILn) is set. The Clock Failure interrupt flag bit in the Interrupt Flag register

(INTFLAG.CLKFAILn) is set. If the CLKFAILn bit in the Interrupt Enable Set register (INTENSET.CLKFAILn) is set, an interrupt is generated. An output event is generated as well, if the Event Output enable bit in the Event Control register (EVCTRL.CFDEOn) is set.

The XOSCn clock continues to be monitored after a clock failure. The Clock Failure status bit in the Status register (STATUS.CLKFAILn) reflects the current XOSCn clock activity.

### Clock Switch

When a clock failure is detected, the XOSCn clock is replaced by the safe clock in order to maintain an active clock during the XOSCn clock failure. The safe clock source is the DFLL48M oscillator clock. The safe clock source can be downscaled with a configurable prescaler to ensure that the safe clock frequency does not exceed the operating conditions selected by the application. When the XOSCn clock is switched to the safe clock, the Clock Switch bit (STATUS.CLKSWn) in the Status register is set.

When the CFD has switched to the safe clock, the XOSCn is not disabled. The application must take the necessary actions to disable the oscillator N. The application must also take the necessary actions to configure the system clocks to continue normal operations.

In the case the application can recover the XOSCn, it can switch back to the XOSCn clock by writing a one to Switch Back bit (XOSCCTRLn.SWBCK) in the External Oscillator Control register. Once the XOSCn clock is switched back, the Switch Back bit (XOSCCTRLn.SWBCK) is cleared by the hardware.

### Prescaler

The CFD has an internal configurable prescaler (XOSCCTRLn.CFDPRESC) to generate the safe clock from the DFLL48M clock. The prescaler size allows to scale down the DFLL48M clock such that the safe clock is not higher than the XOSCn clock frequency monitored by the CFD. The frequency divider is  $2^{CFDPRESC}$  where CFDPRESC range from 0 to 15.

Example: for an external crystal oscillator at 8 MHz and the DFLL48M internal oscillator configured to generate a 48 MHz clock, the prescaler should select a downscale value above 6 (48/8), eg. 8, thus CFDPRESC=3.

### Event

If the Event Output enable bit in the Event Control register (EVCTRL.CFDEOn) is set, the CFD clock failure will be output on the Event Output. When the CFD is switched to the safe clock, the CFD clock failure will not be output on the Event Output.

### Sleep Mode

The CFD is halted depending on configuration of the XOSCn and the peripheral clock request. For further details, refer to the Sleep Behavior table above. The CFD interrupt can be used to wake up the device from sleep modes.

## 28.6.4 Digital Frequency Locked Loop (DFLL48M) Operation

The DFLL48M can operate in both open-loop mode and closed-loop mode. In closed-loop mode, a low-frequency clock with high accuracy should be used as the reference clock to get high accuracy on the output clock (CLK\_DFLL48M).

The DFLL48M can be used as a source for the generic clock generators.

### Related Links

[14. GCLK - Generic Clock Controller](#)



# SAM D5x/E5x Family Data Sheet

## OSCCTRL – Oscillators Controller

### 28.6.4.1 Basic Operation

#### Operating modes

The DFLL48M will behave differently in different sleep modes based on the settings of DFLLCTRLA.RUNSTDBY, DFLLCTRLA.ONDEMAND and DFLLCTRLA.ENABLE, as shown in the following table.

**Table 28-2. DFLL48M Sleep Behavior**

DFLLCTRLA.RUNSTDBY	DFLLCTRLA.ONDEMAND	DFLLCTRLA.ENABLE	Sleep Behavior
-	-	0	Disabled
0	0	1	Always run in Idle Sleep modes. Run in Standby Sleep mode if requested by a peripheral.
0	1	1	Only run in Idle or Standby Sleep modes if requested by a peripheral.
1	0	1	Always run in Idle and Standby Sleep modes.
1	1	1	Only run in Idle or Standby Sleep modes if requested by a peripheral.

The DFLL48M is used as a clock source for the generic clock generators, as described in the GCLK chapter.

The DFLL48M is factory-calibrated for 48MHz. Registers DFLLVAL.COARSE and DFLLVAL.FINE store frequency calibration after reset.

#### Open-Loop Operation

After any reset, the open-loop mode is selected. When operating in open-loop mode, the output frequency of the DFLL48M will be determined by the values written to the DFLL Coarse Value bit group and the DFLL Fine Value bit group (DFLLVAL.COARSE and DFLLVAL.FINE) in the DFLL Value register.

It is possible to change the values of DFLLVAL.COARSE and DFLLVAL.FINE and thereby the output frequency of the DFLL48M output clock, CLK\_DFLL48M, while the DFLL48M is enabled and in use. CLK\_DFLL48M is ready to be used when STATUS.DFLLRDY is set after enabling the DFLL48M.

#### Closed-Loop Operation

In closed-loop operation, the output frequency is continuously regulated against a reference clock. Once the multiplication factor is set, the oscillator fine tuning is automatically adjusted. The DFLL48M must be correctly configured before closed-loop operation can be enabled. After enabling the DFLL48M, it must be configured in the following way:

# SAM D5x/E5x Family Data Sheet

## OSCCTRL – Oscillators Controller

1. Enable and select a reference clock (CLK\_DFLL48M\_REF). CLK\_DFLL48M\_REF is Generic Clock Channel 0 (DFLL48M\_Reference). Refer to GCLK for details.
2. Select the maximum step size allowed in finding the Coarse and Fine values by writing the appropriate values to the DFLL Coarse Maximum Step and DFLL Fine Maximum Step bit groups (DFLLMUL.CSTEP and DFLLMUL.FSTEP) in the DFLL Multiplier register. A small step size will ensure low overshoot on the output frequency, but will typically result in longer lock times. A high value might give a large overshoot, but will typically provide faster locking. DFLLMUL.CSTEP and DFLLMUL.FSTEP should not be higher than 50% of the maximum value of DFLLVAL.COARSE and DFLLVAL.FINE, respectively.
3. Select the multiplication factor in the DFLL Multiply Factor bit group (DFLLMUL.MUL) in the DFLL Multiplier register. Care must be taken when choosing DFLLMUL.MUL so that the output frequency does not exceed the maximum frequency of the device. If the target frequency is below the minimum frequency of the DFLL48M, the output frequency will be equal to the DFLL minimum frequency.
4. Start the closed loop mode by writing a one to the DFLL Mode Selection bit (DFLLCTRLA.MODE) in the DFLL Control register.

The frequency of CLK\_DFLL48M ( $F_{clkdfll48m}$ ) is given by:

$$F_{clkdfll48m} = DFLLMUL.MUL \times F_{clkdfll48mref}$$

where  $F_{clkdfll48mref}$  is the frequency of the reference clock (CLK\_DFLL48M\_REF). DFLLVAL.COARSE and DFLLVAL.FINE are read-only in closed-loop mode, and are controlled by the frequency tuner to meet user specified frequency. In closed-loop mode, the value in DFLLVAL.COARSE is used by the frequency tuner as a starting point for Coarse. Writing DFLLVAL.COARSE to a value close to the final value before entering closed-loop mode will reduce the time needed to get a lock on Coarse.

### Frequency Locking

The locking of the frequency in closed-loop mode is divided into two stages. In the first, coarse stage, the control logic quickly finds the correct value for DFLLVAL.COARSE and sets the output frequency to a value close to the correct frequency. On coarse lock, the DFLL Locked on Coarse Value bit (STATUS.DFLLLOCKC) in the Status register will be set.

In the second, fine stage, the control logic tunes the value in DFLLVAL.FINE so that the output frequency is very close to the desired frequency. On fine lock, the DFLL Locked on Fine Value bit (STATUS.DFLLLOCKF) in the Status register will be set.

If the the ByPass Lock bit (DFLLCTRLB.BPLCKC) in the DFLL Control register is set, the coarse stage is by-passed, the DFLLVAL.COARSE keeps it's value and the DFLL Coarse Value bit (STATUS.DFLLLOCKC) is immediately set.

Interrupts are generated by both STATUS.DFLLLOCKC and STATUS.DFLLLOCKF if INTENSET.DFLLLOCKC or INTENSET.DFLLLOCKF are written to '1'.

CLK\_DFLL48M is ready to be used when the DFLL Ready bit (STATUS.DFLLRDY) in the Status register is set, but the accuracy of the output frequency depends on which locks are set. For lock times, refer to the Electrical Characteristics.

### Frequency Error Measurement

The ratio between CLK\_DFLL48M\_REF and CLK48M\_DFLL is measured automatically when the DFLL48M is in closed loop mode. The difference between this ratio and the value in DFLLMUL.MUL is

stored in the DFLL Multiplication Ratio Difference bit group (DFLLVAL.DIFF) in the DFLL Value register. The relative error on CLK\_DFLL48M compared to the target frequency is calculated as follows:

$$\text{ERROR} = \frac{\text{DIFF}}{\text{MUL}}$$

### Drift Compensation

If the Stable DFLL Frequency bit (DFLLCTRLB.STABLE) in the DFLL Control register is zero, the frequency tuner will automatically compensate for drift in the CLK\_DFLL48M without losing either of the locks. This means that DFLLVAL.FINE can change after every measurement of CLK\_DFLL48M. If the DFLLVAL.FINE value overflows or underflows due to large drift in temperature and/or voltage, the DFLL Out Of Bounds bit (STATUS.DFLLOOB) in the Status register will be set. After an Out of Bounds error condition, the user must rewrite DFLLMUL.MUL to ensure correct CLK\_DFLL48M frequency. An interrupt is generated on a zero-to-one transition on STATUS.DFLLOOB if the DFLL Out Of Bounds bit (INTENSET.DFLLOOB) in the Interrupt Enable Set register is set. This interrupt will also be set if the tuner is not able to lock on the correct Coarse value. If the Stable DFLL Frequency bit (DFLLCTRLB.STABLE) in the DFLL Control register is one, the DFLLVAL.COARSE and DFLLVAL.FINE values will stay constant after the lock. The user can check for a possible drift by reading the frequency error in the DFLL Multiplication Ratio Difference bit group (DFLLVAL.DIFF).

### Reference Clock Stop Detection

If CLK\_DFLL48M\_REF stops or is running at a very low frequency (slower than  $\text{CLK\_DFLL48M}/(2 * \text{MULMAX})$ ), the DFLL Reference Clock Stopped bit (STATUS.DFLLRCS) in the Status register will be set. Detecting a stopped reference clock can take a long time, on the order of  $2^{17}$  CLK\_DFLL48M cycles. When the reference clock is stopped, the DFLL48M will operate as if in open-loop mode. Closed-loop mode operation will automatically resume if the CLK\_DFLL48M\_REF is restarted. An interrupt is generated on a zero-to-one transition on STATUS.DFLLRCS if the DFLL Reference Clock Stopped bit (INTENSET.DFLLRCS) in the Interrupt Enable Set register is set.

### Related Links

[9.4 NVM User Page Mapping](#)

[14. GCLK - Generic Clock Controller](#)

## 28.6.4.2 Additional Features

### Dealing with Delay in the DFLL in Closed-Loop Mode

The time from selecting a new CLK\_DFLL48M frequency until this frequency is output by the DFLL48M can be up to several microseconds. If the value in DFLLMUL.MUL is small, this can lead to instability in the DFLL48M locking mechanism, which can prevent the DFLL48M from achieving locks. To avoid this, a chill cycle, during which the CLK\_DFLL48M frequency is not measured, can be enabled. The chill cycle is enabled by default, but can be disabled by writing a one to the DFLL Chill Cycle Disable bit (DFLLCTRLB.CCDIS) in the DFLL Control register. Enabling chill cycles might double the lock time.

Another solution to this problem consists of using less strict lock requirements. This is called Quick Lock (QL), which is also enabled by default, but it can be disabled by writing a one to the Quick Lock Disable bit (DFLLCTRLB.QLDIS) in the DFLL Control register. The Quick Lock might lead to a larger spread in the output frequency than chill cycles, but the average output frequency is the same.

### USB Clock Recovery Mode

USB Clock Recovery mode can be used to create the 48MHz USB clock from the USB Start Of Frame (SOF). This mode is enabled by writing a '1' to both the USB Clock Recovery Mode bit and the Mode bit in DFLL Control register (DFLLCTRLB.USBCRM and DFLLCTRLB.MODE).

In USB Clock Recovery mode, the status bits of the DFLL in OSCCTRL.STATUS are determined by the USB bus activity, and have no valid meaning. The SOF signal from USB device will be used as reference clock (CLK\_DFLL\_REF), ignoring the selected generic clock reference. When the USB device is connected, a SOF will be sent every 1ms, thus DFLLVAL.MUX bits should be written to 0xBB80 to obtain a 48MHz clock. In USB clock recovery mode, the DFLLCTRLB.BPLCKC bit state is ignored, and the value stored in the DFLLVAL.COARSE will be used as final Coarse value.

The COARSE value for a calibrated 48 MHz frequency is loaded from NVM after any system reset and may vary in operating modes different of the USB Clock Recovery Mode. The initial COARSE value can be saved and restored by the software if necessary.

The locking procedure will also go instantaneously to the fine lock search.

The DFLLCTRLB.QLDIS bit must be cleared and DFLLCTRLB.CCDIS should be set to speed up the lock phase. The DFLLCTRLB.STABLE bit state is ignored, an auto jitter reduction mechanism is used instead.

### Wake from Sleep Modes

DFLL48M can optionally reset its lock bits when it is disabled. This is configured by the Lose Lock After Wake bit (DFLLCTRLB.LLAW) in the DFLL Control register. If DFLLCTRLB.LLAW is zero, the DFLL48M will be re-enabled and start running with the same configuration as before being disabled, even if the reference clock is not available. The locks will not be lost. Thus it is important that the user checks that the DFLL48M has reached the COARSE and FINE lock stage before entering a sleep mode. When the reference clock has restarted, the Fine tracking will quickly compensate for any frequency drift during sleep if DFLLCTRLB.STABLE is zero. If DFLLCTRLB.LLAW is one when disabling the DFLL48M, the DFLL48M will lose all its locks, and needs to regain these through the full lock sequence.

### Wait for Lock

DFLL48M can optionally control the issued clock. This is configured by the Wait For Lock bit (DFLLCTRLB.WAITLOCK) in the DFLL Control register. If DFLLCTRLB.WAITLOCK is zero, the DFLL48M will issue a clock immediately after the ready bit (STATUS.DFLLRDY) has risen. If DFLLCTRLB.WAITLOCK is one, the DFLL48M will issue a clock immediately after the fine lock bit (STATUS.DFLLCKF) has risen. Using the wait for lock feature allows a better accuracy of the issued DFLL48M clock, conversely it increases the startup time of the DFLL48M clock.

### Accuracy

There are two main factors that determine the accuracy of Fclkdfll48m. These can be tuned to obtain maximum accuracy when fine lock is achieved.

- Fine resolution: The frequency step between two Fine values.
- The accuracy of the reference clock.

### 28.6.5 Digital Phase Locked Loop (DPLL) Operation

The task of the DPLL is to maintain coherence between the input (reference) signal and the respective output frequency CLK\_DPLL through phase comparison. The DPLL controller supports four independent sources of reference clocks:

- XOSC32K: This clock is provided by the 32K External Crystal Oscillator (XOSC32K).

- XOSC0 and XOSC1: These clocks are provided by the External Multipurpose Crystal Oscillator (XOSC).
- GCLK: This clock is provided by the Generic Clock Controller.

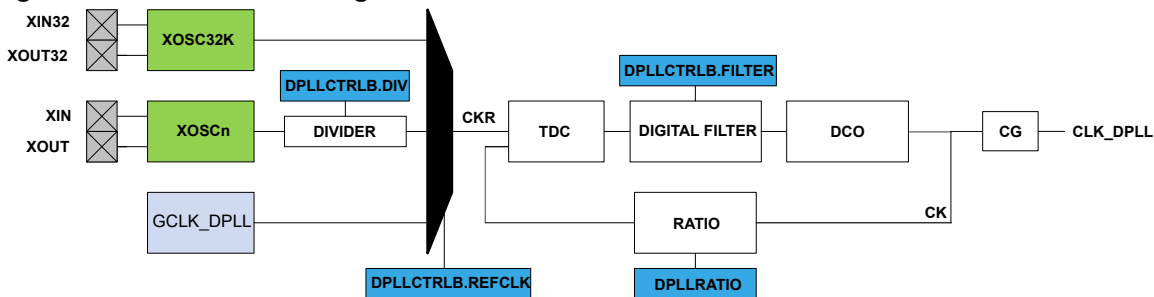
When the controller is enabled, the relationship between the reference clock frequency and the output clock frequency is as shown below:

$$f_{\text{CLK\_DPLL}_n} = f_{\text{CKR}} \times \left( \text{LDR} + 1 + \frac{\text{LDRFRAC}}{32} \right)$$

Where:

$f_{\text{CLK\_DPLL}_n}$  is the frequency of the DPLL output clock, LDR is the loop divider ratio integer part and LDRFRAC is the loop divider ratio fractional part,  $f_{\text{CKR}}$  is the frequency of the selected reference clock.

**Figure 28-2. DPLL Block Diagram**



When the controller is disabled, the output clock is low. If the Loop Divider Ratio Fractional part bit field in the DPLL Ratio register (DPLL\_RATIO.LDRFRAC) is zero, the DPLL works in Integer mode. Otherwise, the fractional mode is activated. The fractional part has a negative impact on the jitter of the DPLL.

For example (Integer mode only): Assuming  $f_{\text{CKR}} = 32 \text{ kHz}$  and  $f_{\text{CLK\_DPLL}_n} = 112 \text{ MHz}$ , the multiplication ratio is 3500. It means that LDR must be set to 3499.

For example (Fractional mode): Assuming  $f_{\text{CKR}} = 32 \text{ kHz}$  and  $f_{\text{CLK\_DPLL}_n} = 112.003000 \text{ MHz}$ , the multiplication ratio is 3500.9375 ( $3500 + 3/32$ ). Thus LDR is set to 3499 and LDRFRAC to 3.

### Related Links

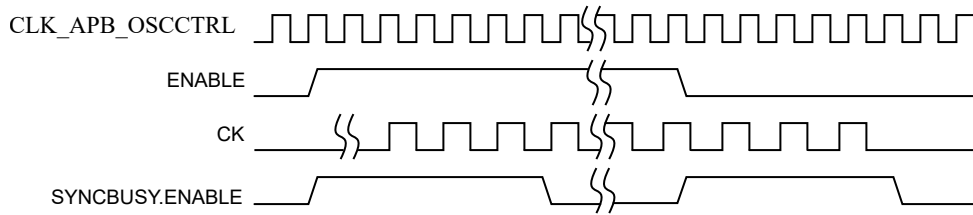
- [14. GCLK - Generic Clock Controller](#)
- [29. OSC32KCTRL – 32KHz Oscillators Controller](#)

### 28.6.5.1 Basic Operation

#### Initialization, Enabling, Disabling, and Resetting

The DPLL<sub>Cn</sub> is enabled by writing a '1' to the Enable bit in the Control register (DPLL<sub>Cn</sub>CTRLA.ENABLE). The DPLL<sub>Cn</sub> is disabled by writing a '0' to DPLL<sub>Cn</sub>CTRLA.ENABLE. The DPLL<sub>Cn</sub>SYNCBUSY.ENABLE is set when the DPLL<sub>Cn</sub>CTRLA.ENABLE bit is modified. It is cleared when the DPLL<sub>Cn</sub> output clock CLK\_DPLL<sub>n</sub> has sampled the bit at the high level, or cleared when the output clock is no longer running (for disable operation).

**Figure 28-3. Enable synchronization busy operation**



The frequency of the DPLL<sub>Cn</sub> output clock CLK\_DPLL<sub>n</sub> is stable when the module is enabled and when the LOCK bit is set. When DPLL<sub>n</sub>CTRLB.LTIME is different from 0, a user defined lock time is used to validate the lock operation. In that case the lock time is constant. If DPLL<sub>n</sub>CTRLB.LTIME is zero, the lock signal is linked with the status bit of the DPLL<sub>Cn</sub> (DPLL<sub>n</sub>STATUS.LOCK), the lock time vary depending on the filter selection and final target frequency. When DPLL<sub>n</sub>CTRLB.WUF is set the wake up fast mode is activated. In that mode the clock gating cell is enabled at the end of the startup time. At that time the final frequency is not stable as it is still the acquisition period, but it allows to save hundreds of microseconds. After the first acquisition, DPLL<sub>n</sub>CTRLB.LBYPASS indicates if the Lock signal is discarded from the control of the clock gater (CG) generating the output clock CLK\_DPLL<sub>n</sub>.

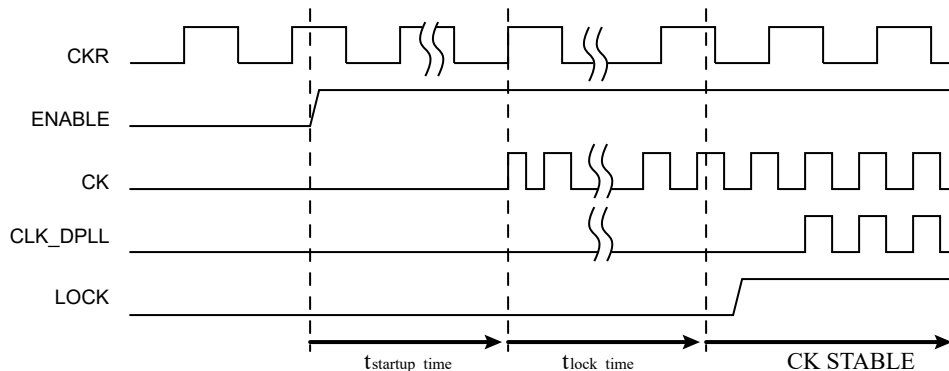
**Table 28-3. CLK\_DPLL<sub>n</sub> behavior from startup to first edge detection.**

WUF	LTIME	CLK_DPLL <sub>n</sub> Behavior
0	0	Normal Mode: First Edge when lock is asserted
0	Not Equal To Zero	Lock Timer Timeout mode: First Edge when the timer down-counts to 0.
1	X	Wake Up Fast Mode: First Edge when CK is active (startup time)

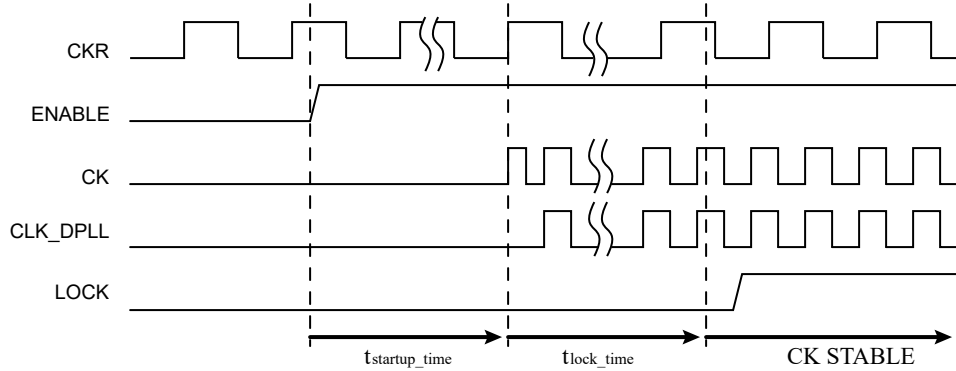
**Table 28-4. CLK\_DPLL<sub>n</sub> behavior after First Edge detection.**

LBYPASS	CLK_DPLL <sub>n</sub> Behavior
0	Normal Mode: the CLK_DPLL <sub>n</sub> is turned off when lock signal is low.
1	Lock Bypass Mode: the CLK_DPLL <sub>n</sub> is always running, lock is irrelevant.

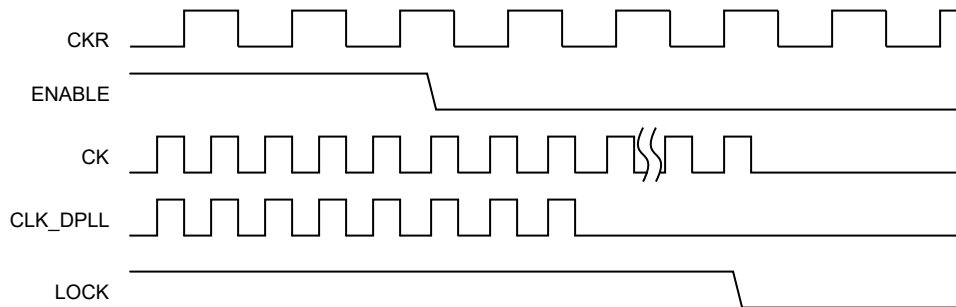
**Figure 28-4. CK and CLK\_DPLL output from DPLL off mode to running mode**



**Figure 28-5. CK and CLK\_DPLL output from DPLL off mode to running mode when wake up fast is activated**



**Figure 28-6. CK and CLK\_DPLL output from running mode to DPLL off mode.**



### Operating modes

The DPLL<sub>n</sub> will behave differently in different sleep modes based on the settings of DPLL<sub>n</sub>CTRLA.RUNSTDBY, DPLL<sub>n</sub>CTRLA.ONDEMAND and DPLL<sub>n</sub>CTRLA.ENABLE.

**Table 28-5. DPLL Sleep Behavior**

DPLLCTRLA.RUNSTDBY	DPLLCTRLA.ONDEMAND	DPLLCTRLA.ENABLE	Sleep Behavior
-	-	0	Disabled
0	0	1	Always run in Idle Sleep modes. Run in Standby Sleep mode if requested by a peripheral.
0	1	1	Only run in Idle or Standby Sleep modes if requested by a peripheral.
1	0	1	Always run in Idle and Standby Sleep modes.
1	1	1	Only run in Idle or Standby Sleep modes if requested by a peripheral.

### Reference Clock Switching

When a software operation requires reference clock switching, the normal operation is to disable the DPLLn, modify the DPLLnCTRLB.REFCLK to select the desired reference source and activate the DPLLn again. The CLK\_DPLLn output clock is ready when DPLLnSTATUS.CLKRDY bit is set.

### XOSC Reference Clock Divider

DPLLnCTRLB.DIV[10:0] bits are used to set the XOSC clock division factor and can be calculated with following formula:

$$f_{DIV} = \frac{f^{XOSC}}{2 \times (DIV + 1)}$$

For more information, refer to DPLLnCTRLB.

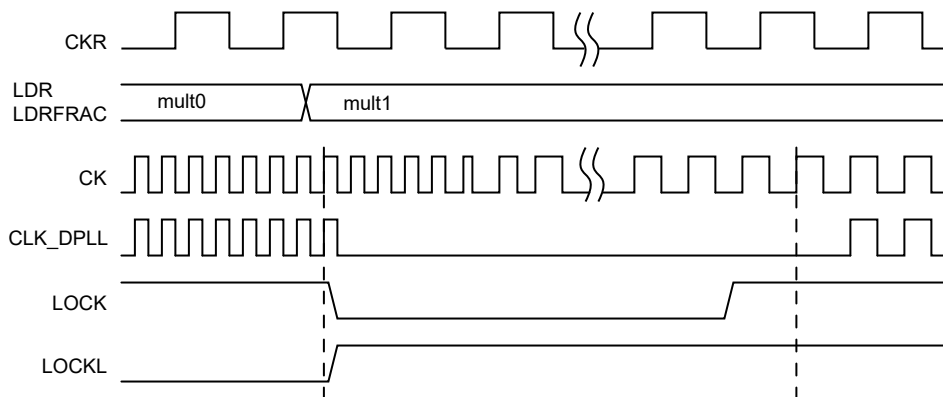
### Loop Divider Ratio Updates

The DPLLn Controller supports on-the-fly update of the DPLLnRATIO register, so it is allowed to modify the loop divider ratio and the loop divider ratio fractional part when the DPLLn is enabled. Ensure the following conditions, or else the on-the-fly updating of the divider ratio will fail:

- DPLLnCTRLB.LBYPASS must be '0' (normal mode).
- DPLLnCTRLB.LTIME must not be 0x0, which is the default value.
- A DPLLn 32KHz clock (GCLK\_DPLLn\_32K) is configured in the GCLK peripheral as the internal lock timer.

Write DPLLnRATIO.LDR[12:0] bits to set the integer part of the frequency multiplier, and write DPLLnRATIO.LDRFRAC[4:0] bits to set the fractional part of the frequency multiplier. Due to synchronization there is a delay between writing to DPLLnRATIO.LDRFRAC[4:0] or DPLLnRATIO.LDR[12:0] and the effect on the DPLLn output clock. The value written DPLLnRATIO.LDRFRAC[4:0] or DPLLnRATIO.LDR[12:0] will be read back immediately, and the DPLLRATIO bit in the synchronization busy register DPLLnSYNCBUSY.DPLL\_RATIO, will be set. DPLLnSYNCBUSY.DPLL\_RATIO will be cleared when the operation is completed. STATUS.DPLLnLDRTO is set when the DPLLnRATIO register has been modified and the DPLLn analog cell has successfully sampled the updated value. At that time the DPLLnSTATUS.LOCK bit is cleared and set again by hardware when the output frequency reached a stable state. Note that if only the fractional part of loop divider ratio (DPLLnRATIO.LDRFRAC) is updated, the lock status (DPLLnSTATUS.LOCK) will not be cleared.

**Figure 28-7. RATIOCTRL register update operation**





### Digital Filter Selection

The digital filter selection can be changed from the filter selection register `DPLLnCTRLB.FILTER`. The DPLL digital filter coefficients are automatically adjusted in order to provide a good compromise between stability and jitter. For more information, refer to `DPLLnCTRLB`.

### Sigma-Delta DCO Filter Selection

The sigma-delta DAC low pass filter can be controlled and adjusted from the DCO filter selection register `DPLLnCTRLB.DCOFILTER[2:0]`. For more information, refer to `DPLLnCTRLB`.

### Related Links

[14. GCLK - Generic Clock Controller](#)

## 28.6.6 DMA Operation

Not applicable.

## 28.6.7 Interrupts

The OSCCTRL has the following interrupt sources:

- `XOSCRDY` - Multipurpose Crystal Oscillator Ready: A "0-to-1" transition on the `STATUS.XOSCRDY` bit is detected
- `CLKFAIL` - Clock Failure . A "0-to-1" transition on the `STATUS.CLKFAIL` bit is detected.
- `DFLLRDY` - `DFLL48m` Ready: A "0-to-1" transition on the `STATUS.DFLLRDY` bit is detected
- `DPLLnLOCKR` - `DPLLn` Lock Rise: A "0-to-1" transition on the `STATUS.DPLLnLOCKR` bit is detected
- `DPLLnLOCKF` - `DPLLn` Lock Fall: A "0-to-1" transition on the `STATUS.DPLLnLOCKF` bit is detected
- `DPLLnLTTO` - `DPLLn` Lock Timer Time-out: A "0-to-1" transition on the `STATUS.DPLLnLTTO` bit is detected
- `DPLLnLDRTO` - `DPLLn` Loop Divider Ratio Update Complete. A "0-to-1" transition on the `STATUS.DPLLnLDRTO` bit is detected

Each interrupt source has an interrupt flag associated with it. The interrupt flag in the Interrupt Flag Status and Clear register (`INTFLAG`) is set when the interrupt condition occurs. Each interrupt can be individually enabled by writing a one to the corresponding bit in the Interrupt Enable Set register (`INTENSET`), and disabled by writing a one to the corresponding bit in the Interrupt Enable Clear register (`INTENCLR`). An interrupt request is generated when the interrupt flag is set and the corresponding interrupt is enabled. The interrupt request remains active until the interrupt flag is cleared, the interrupt is disabled or the OSCCTRL is reset. `INTFLAG` register for details on how to clear interrupt flags.

The OSCCTRL has one common interrupt request line for all the interrupt sources. The user must read the `INTFLAG` register to determine which interrupt condition is present.

Note that interrupts must be globally enabled for interrupt requests to be generated.

## 28.6.8 Events

The CFD can generate the following output event:

- Clock Failure (`CLKFAIL`): Generated when the Clock Failure status bit is set in the Status register (`STATUS.CLKFAIL`). The CFD event is not generated when the Clock Switch bit (`STATUS.CLKSW`) in the Status register is set.

Writing a '1' to an Event Output bit in the Event Control register (`EVCTRL.CFDEO`) enables the CFD output event. Writing a '0' to this bit disables the CFD output event. Refer to the *Event System* chapter for details on configuring the event system.

### 28.6.9 Synchronization

Due to the multiple clock domains, some registers in the DFLL48M must be synchronized when accessed. A register can require:

- Synchronization when written
- Synchronization when read
- No synchronization

When executing an operation that requires synchronization, the relevant synchronization bit in the Synchronization Busy register (DFLLSYNC) will be set immediately, and cleared when synchronization is complete.

The following registers need synchronization:

- ENABLE bit in DFLLCTRLA register - write-synchronized
- DFLLCTRLB register - read-synchronized
- DFLLVAL register - read- and write-synchronized
- DFLLMUL register - write-synchronized

Due to the multiple clock domains (XOSC32K, XOSC, GCLK and CK), some registers in the DPLL must be synchronized when accessed. A register can require:

- Synchronization when written
- No synchronization

When executing an operation that requires synchronization, the relevant synchronization bit in the Synchronization Busy register (DPLLnSYNCBUSY) will be set immediately, and cleared when synchronization is complete.

The following bits need synchronization when written:

- Enable bit in control register A (DPLLnCTRLA.ENABLE)
- DPLLn Ratio register (DPLLnRATIO)

# SAM D5x/E5x Family Data Sheet

## OSCCTRL – Oscillators Controller

### 28.7 Register Summary

Offset	Name	Bit Pos.								
0x00	EVCTRL	7:0							CFDE01	CFDE00
0x01 ... 0x03	Reserved									
0x04	INTENCLR	7:0					XOSCFAIL1	XOSCFAIL0	XOSCRDY1	XOSCRDY0
		15:8				DFLLRCS	DFLLLCKC	DFLLLCKF	DFLLOOB	DFLLRDY
		23:16					DPLL0LDRTO	DPLL0LTO	DPLL0LCKF	DPLL0LCKR
		31:24					DPLL1LDRTO	DPLL1LTO	DPLL1LCKF	DPLL1LCKR
0x08	INTENSET	7:0					XOSCFAIL1	XOSCFAIL0	XOSCRDY1	XOSCRDY0
		15:8				DFLLRCS	DFLLLCKC	DFLLLCKF	DFLLOOB	DFLLRDY
		23:16					DPLL0LDRTO	DPLL0LTO	DPLL0LCKF	DPLL0LCKR
		31:24					DPLL1LDRTO	DPLL1LTO	DPLL1LCKF	DPLL1LCKR
0x0C	INTFLAG	7:0					XOSCFAIL	XOSCRDY1	XOSCRDY0	
		15:8				DFLLRCS	DFLLLCKC	DFLLLCKF	DFLLOOB	DFLLRDY
		23:16					DPLL0LDRTO	DPLL0LTO	DPLL0LCKF	DPLL0LCKR
		31:24					DPLL1LDRTO	DPLL1LTO	DPLL1LCKF	DPLL1LCKR
0x10	STATUS	7:0			XOSCCKSW1	XOSCCKSW0	XOSCFAIL1	XOSCFAIL0	XOSCRDY1	XOSCRDY0
		15:8				DFLLRCS	DFLLLCKC	DFLLLCKF	DFLLOOB	DFLLRDY
		23:16					DPLL0LDRTO	DPLL0LTO	DPLL0LCKF	DPLL0LCKR
		31:24					DPLL1LDRTO	DPLL1LTO	DPLL1LCKF	DPLL1LCKR
0x14	XOSCCTRL0	7:0	ONDEMAND	RUNSTDBY				XTALEN	ENABLE	
		15:8	ENALC		IMULT[3:0]			IPTAT[1:0]		LOWBUFGAIN
		23:16	STARTUP[3:0]					SWBEN	CFDEN	
		31:24				CFDPRESC[3:0]				
0x18	XOSCCTRL1	7:0	ONDEMAND	RUNSTDBY				XTALEN	ENABLE	
		15:8	ENALC		IMULT[3:0]			IPTAT[1:0]		LOWBUFGAIN
		23:16	STARTUP[3:0]					SWBEN	CFDEN	
		31:24				CFDPRESC[3:0]				
0x1C	DFLLCTRLA	7:0	ONDEMAND	RUNSTDBY				ENABLE		
0x1D ... 0x1F	Reserved									
0x20	DFLLCTRLB	7:0	WAITLOCK	BPLCKC	QLDIS	CCDIS	USBCRM	LLAW	STABLE	MODE
0x21 ... 0x23	Reserved									
0x24	DFLLVAL	7:0	FINE[7:0]							
		15:8	COARSE[5:0]							
		23:16	DIFF[7:0]							
		31:24	DIFF[15:8]							

# SAM D5x/E5x Family Data Sheet

## OSCCTRL – Oscillators Controller

.....continued

Offset	Name	Bit Pos.									
0x28	DFLLMUL	7:0	MUL[7:0]								
		15:8	MUL[15:8]								
		23:16	FSTEP[7:0]								
		31:24	CSTEP[5:0]								
0x2C	DFLLSYNC	7:0				DFLLMUL	DFLLVAL	DFLLCTRLB	ENABLE		
0x2D ... 0x2F	Reserved										
0x30	DPLL0CTRLA	7:0	ONDEMAND	RUNSTDBY					ENABLE		
0x31 ... 0x33	Reserved										
0x34	DPLL0RATIO	7:0	LDR[7:0]								
		15:8	LDR[12:8]								
		23:16	LDRFRAC[4:0]								
		31:24									
0x38	DPLL0CTRLB	7:0	REFCLK[2:0]			WUF	FILTER[3:0]				
		15:8	DCOEN	DCOFILTER[2:0]			LBYPASS	LTIME[2:0]			
		23:16	DIV[7:0]								
		31:24								DIV[10:8]	
0x3C	DPLL0SYNCBUSY	7:0						DPLL0RATIO	ENABLE		
		15:8									
		23:16									
		31:24									
0x40	DPLL0STATUS	7:0							CLKRDY	LOCK	
		15:8									
		23:16									
		31:24									
0x44	DPLL1CTRLA	7:0	ONDEMAND	RUNSTDBY				ENABLE			
0x45 ... 0x47	Reserved										
0x48	DPLL1RATIO	7:0	LDR[7:0]								
		15:8	LDR[12:8]								
		23:16	LDRFRAC[4:0]								
		31:24									
0x4C	DPLL1CTRLB	7:0	REFCLK[2:0]			WUF	FILTER[3:0]				
		15:8	DCOEN	DCOFILTER[2:0]			LBYPASS	LTIME[2:0]			
		23:16	DIV[7:0]								
		31:24								DIV[10:8]	
0x50	DPLL1SYNCBUSY	7:0						DPLL1RATIO	ENABLE		
		15:8									
		23:16									
		31:24									

.....continued

Offset	Name	Bit Pos.								
0x54	DPLL1STATUS	7:0							CLKRDY	LOCK
		15:8								
		23:16								
		31:24								

### 28.8 Register Description

Registers can be 8, 16, or 32 bits wide. Atomic 8-, 16-, and 32-bit accesses are supported. In addition, the 8-bit quarters and 16-bit halves of a 32-bit register and the 8-bit halves of a 16-bit register can be accessed directly.

Some registers are optionally write-protected by the Peripheral Access Controller (PAC). Write-protection is denoted by the "PAC Write-Protection" property in each individual register description. Refer to the [28.5.8 Register Access Protection](#) section and the PAC - Peripheral Access Controller chapter for details.

Some registers require synchronization when read and/or written. Synchronization is denoted by the "Read-Synchronized" or "Write-Synchronized" property in each individual register description. Refer to the section on Synchronization for details.

#### Related Links

[28.6.9 Synchronization](#)

### 28.8.1 Event Control

**Name:** EVCTRL  
**Offset:** 0x00  
**Reset:** 0x00  
**Property:** PAC Write-Protection

	7	6	5	4	3	2	1	0
Bit							CFDEO1	CFDEO0
Access	R	R	R	R	R	R	R/W	R/W
Reset	0	0	0	0	0	0	0	0

**Bits 0, 1 – CFDEO** Clock n Failure Detector Event Output Enable [n=0,1]

This bit indicates whether the XOSC Clock Failure detector event output is enabled or not and an output event will be generated when the XOSC Clock Failure detector detects a clock failure.

0: Clock Failure detector event output is disabled and an event will not be generated.

1: Clock Failure detector event output is enabled and an event will be generated.

To prevent false event generation, the bit CFDEOn must be set or cleared only when the XOSCn is disabled (XOSCCTRLn.ENABLE=0).

# SAM D5x/E5x Family Data Sheet

## OSCCTRL – Oscillators Controller

### 28.8.2 Interrupt Enable Clear

**Name:** INTENCLR  
**Offset:** 0x04  
**Reset:** 0x00000000  
**Property:** PAC Write-Protection

This register allows the user to disable an interrupt without doing a read-modify-write operation. Changes in this register will also be reflected in the Interrupt Enable Set register (INTENSET).

Bit	31	30	29	28	27	26	25	24
					DPLL1LDRTO	DPLL1LTO	DPLL1LCKF	DPLL1LCKR
Access					R/W	R/W	R/W	R/W
Reset					0	0	0	0
Bit	23	22	21	20	19	18	17	16
					DPLL0LDRTO	DPLL0LTO	DPLL0LCKF	DPLL0LCKR
Access					R/W	R/W	R/W	R/W
Reset					0	0	0	0
Bit	15	14	13	12	11	10	9	8
				DFLLRCS	DFLLLCKC	DFLLLCKF	DFLLOOB	DFLLRDY
Access				R/W	R/W	R/W	R/W	R/W
Reset				0	0	0	0	0
Bit	7	6	5	4	3	2	1	0
					XOSCFail1	XOSCFail0	XOSCRDY1	XOSCRDY0
Access					R/W	R/W	R/W	R/W
Reset					0	0	0	0

**Bit 27 – DPLL1LDRTO** DPLL1 Loop Divider Ratio Update Complete Interrupt Enable

0: The DPLL1 Loop Divider Ratio Update Complete interrupt is disabled.

1: The DPLL1 Loop Divider Ratio Update Complete interrupt is enabled, and an interrupt request will be generated when the DPLL1 Loop Divider Ratio Update Complete Interrupt flag is set.

Writing a zero to this bit has no effect.

Writing a '1' to this bit will clear the DPLL1 Loop Divider Ratio Update Complete Interrupt Enable bit, which disables the DPLL1 Loop Divider Ratio Update Complete interrupt.

**Bit 26 – DPLL1LTO** DPLL1 Lock Timeout Interrupt Enable

0: The DPLL1 Lock Timeout interrupt is disabled.

1: The DPLL1 Lock Timeout interrupt is enabled, and an interrupt request will be generated when the DPLL1 Lock Timeout Interrupt flag is set.

Writing a zero to this bit has no effect.

Writing a '1' to this bit will clear the DPLL1 Lock Timeout Interrupt Enable bit, which disables the DPLL1 Lock Timeout interrupt.

**Bit 25 – DPLL1LCKF** DPLL1 Lock Fall Interrupt Enable

0: The DPLL1 Lock Fall interrupt is disabled.

1: The DPLL1 Lock Fall interrupt is enabled, and an interrupt request will be generated when the DPLL1 Lock Fall Interrupt flag is set.

Writing a zero to this bit has no effect.

Writing a '1' to this bit will clear the DPLL1 Lock Fall Interrupt Enable bit, which disables the DPLL1 Lock Fall interrupt.

**Bit 24 – DPLL1LCKR** DPLL1 Lock Rise Interrupt Enable

0: The DPLL1 Lock Rise interrupt is disabled.

1: The DPLL1 Lock Rise interrupt is enabled, and an interrupt request will be generated when the DPLL1 Lock Rise Interrupt flag is set.

Writing a zero to this bit has no effect.

Writing a '1' to this bit will clear the DPLL1 Lock Rise Interrupt Enable bit, which disables the DPLL1 Lock Rise interrupt.

**Bit 19 – DPLL0LDRTO** DPLL0 Loop Divider Ratio Update Complete Interrupt Enable

0: The DPLL0 Loop Divider Ratio Update Complete interrupt is disabled.

1: The DPLL0 Loop Divider Ratio Update Complete interrupt is enabled, and an interrupt request will be generated when the DPLL0 Loop Divider Ratio Update Complete Interrupt flag is set.

Writing a zero to this bit has no effect.

Writing a '1' to this bit will clear the DPLL0 Loop Divider Ratio Update Complete Interrupt Enable bit, which disables the DPLL0 Loop Divider Ratio Update Complete interrupt.

**Bit 18 – DPLL0LTO** DPLL0 Lock Timeout Interrupt Enable

0: The DPLL0 Lock Timeout interrupt is disabled.

1: The DPLL0 Lock Timeout interrupt is enabled, and an interrupt request will be generated when the DPLL0 Lock Timeout Interrupt flag is set.

Writing a zero to this bit has no effect.

Writing a '1' to this bit will clear the DPLL0 Lock Timeout Interrupt Enable bit, which disables the DPLL0 Lock Timeout interrupt.

**Bit 17 – DPLL0LCKF** DPLL0 Lock Fall Interrupt Enable

0: The DPLL0 Lock Fall interrupt is disabled.

1: The DPLL0 Lock Fall interrupt is enabled, and an interrupt request will be generated when the DPLL0 Lock Fall Interrupt flag is set.

Writing a zero to this bit has no effect.

Writing a '1' to this bit will clear the DPLL0 Lock Fall Interrupt Enable bit, which disables the DPLL0 Lock Fall interrupt.

**Bit 16 – DPLL0LCKR** DPLL0 Lock Rise Interrupt Enable

0: The DPLL0 Lock Rise interrupt is disabled.

1: The DPLL0 Lock Rise interrupt is enabled, and an interrupt request will be generated when the DPLL0 Lock Rise Interrupt flag is set.

Writing a zero to this bit has no effect.

Writing a '1' to this bit will clear the DPLL0 Lock Rise Interrupt Enable bit, which disables the DPLL0 Lock Rise interrupt.

**Bit 12 – DFLLRCS** DFLL Reference Clock Stopped Interrupt Enable

0: The DFLL Reference Clock Stopped interrupt is disabled.

1: The DFLL Reference Clock Stopped interrupt is enabled, and an interrupt request will be generated when the DFLL Reference Clock Stopped Interrupt flag is set.

Writing a zero to this bit has no effect.



# SAM D5x/E5x Family Data Sheet

## OSCCTRL – Oscillators Controller

---

Writing a '1' to this bit will clear the DFLL Reference Clock Stopped Interrupt Enable bit, which disables the DFLL Reference Clock Stopped interrupt.

### **Bit 11 – DFLLCKC** DFLL Lock Coarse Interrupt Enable

0: The DFLL Lock Coarse interrupt is disabled.

1: The DFLL Lock Coarse interrupt is enabled, and an interrupt request will be generated when the DFLL Lock Coarse Interrupt flag is set.

Writing a zero to this bit has no effect.

Writing a '1' to this bit will clear the DFLL Lock Coarse Interrupt Enable bit, which disables the DFLL Lock Coarse interrupt.

### **Bit 10 – DFLLCKF** DFLL Lock Fine Interrupt Enable

0: The DFLL Lock Fine interrupt is disabled.

1: The DFLL Lock Fine interrupt is enabled, and an interrupt request will be generated when the DFLL Lock Fine Interrupt flag is set.

Writing a zero to this bit has no effect.

Writing a '1' to this bit will clear the DFLL Lock Fine Interrupt Enable bit, which disables the DFLL Lock Fine interrupt.

### **Bit 9 – DFLL0OB** DFLL Out Of Bounds Interrupt Enable

0: The DFLL Out Of Bounds interrupt is disabled.

1: The DFLL Out Of Bounds interrupt is enabled, and an interrupt request will be generated when the DFLL Out Of Bounds Interrupt flag is set.

Writing a zero to this bit has no effect.

Writing a '1' to this bit will clear the DFLL Out Of Bounds Interrupt Enable bit, which disables the DFLL Out Of Bounds interrupt.

### **Bit 8 – DFLLRDY** DFLL Ready Interrupt Enable

0: The DFLL Ready interrupt is disabled.

1: The DFLL Ready interrupt is enabled, and an interrupt request will be generated when the DFLL Ready Interrupt flag is set.

Writing a zero to this bit has no effect.

Writing a '1' to this bit will clear the DFLL Ready Interrupt Enable bit, which disables the DFLL Ready interrupt.

### **Bits 2, 3 – XOSCFAIL** XOSC n Clock Failure Interrupt Enable

0: The XOSC n Clock Failure interrupt is disabled.

1: The XOSC0 Clock Failure interrupt is enabled, and an interrupt request will be generated when the XOSC0 Clock Failure Interrupt flag is set.

Writing a zero to this bit has no effect.

Writing a '1' to this bit will clear the XOSC n Clock Failure Interrupt Enable bit, which disables the XOSC n Clock Failure interrupt.

### **Bits 0, 1 – XOSCRDY** XOSC n Ready Interrupt Enable

0: The XOSC n Ready interrupt is disabled.

1: The XOSC0 Ready interrupt is enabled, and an interrupt request will be generated when the XOSC n Ready Interrupt flag is set.

Writing a zero to this bit has no effect.

Writing a '1' to this bit will clear the XOSC n Ready Interrupt Enable bit, which disables the XOSC n Ready interrupt.

# SAM D5x/E5x Family Data Sheet

## OSCCTRL – Oscillators Controller

### 28.8.3 Interrupt Enable Set

**Name:** INTENSET  
**Offset:** 0x08  
**Reset:** 0x00000000  
**Property:** PAC Write-Protection

This register allows the user to enable an interrupt without doing a read-modify-write operation. Changes in this register will also be reflected in the Interrupt Enable Clear register (INTENCLR).

Bit	31	30	29	28	27	26	25	24
					DPLL1LDRTO	DPLL1LTO	DPLL1LCKF	DPLL1LCKR
Access					R/W	R/W	R/W	R/W
Reset					0	0	0	0
Bit	23	22	21	20	19	18	17	16
					DPLL0LDRTO	DPLL0LTO	DPLL0LCKF	DPLL0LCKR
Access					R/W	R/W	R/W	R/W
Reset					0	0	0	0
Bit	15	14	13	12	11	10	9	8
				DFLLRCS	DFLLLCKC	DFLLLCKF	DFLLOOB	DFLLRDY
Access				R/W	R/W	R/W	R/W	R/W
Reset				0	0	0	0	0
Bit	7	6	5	4	3	2	1	0
					XOSCFail1	XOSCFail0	XOSCRDY1	XOSCRDY0
Access					R/W	R/W	R/W	R/W
Reset					0	0	0	0

**Bit 27 – DPLL1LDRTO** DPLL1 Loop Divider Ratio Update Complete Interrupt Enable

0: The DPLL1 Loop Divider Ratio Update Complete interrupt is disabled.

1: The DPLL1 Loop Divider Ratio Update Complete interrupt is enabled, and an interrupt request will be generated when the DPLL1 Loop Divider Ratio Update Complete Interrupt flag is set.

Writing a zero to this bit has no effect.

Writing a '1' to this bit will set the DPLL1 Loop Divider Ratio Update Complete Interrupt Enable bit, which enables the DPLL1 Loop Divider Ratio Update Complete interrupt.

**Bit 26 – DPLL1LTO** DPLL1 Lock Timeout Interrupt Enable

0: The DPLL1 Lock Timeout interrupt is disabled.

1: The DPLL1 Lock Timeout interrupt is enabled, and an interrupt request will be generated when the DPLL1 Lock Timeout Interrupt flag is set.

Writing a zero to this bit has no effect.

Writing a '1' to this bit will set the DPLL1 Lock Timeout Interrupt Enable bit, which enables the DPLL1 Lock Timeout interrupt.

**Bit 25 – DPLL1LCKF** DPLL1 Lock Fall Interrupt Enable

0: The DPLL1 Lock Fall interrupt is disabled.

1: The DPLL1 Lock Fall interrupt is enabled, and an interrupt request will be generated when the DPLL1 Lock Fall Interrupt flag is set.

Writing a zero to this bit has no effect.

Writing a '1' to this bit will set the DPLL1 Lock Fall Interrupt Enable bit, which enables the DPLL1 Lock Fall interrupt.

**Bit 24 – DPLL1LCKR** DPLL1 Lock Rise Interrupt Enable

0: The DPLL1 Lock Rise interrupt is disabled.

1: The DPLL1 Lock Rise interrupt is enabled, and an interrupt request will be generated when the DPLL1 Lock Rise Interrupt flag is set.

Writing a zero to this bit has no effect.

Writing a '1' to this bit will set the DPLL1 Lock Rise Interrupt Enable bit, which enables the DPLL1 Lock Rise interrupt.

**Bit 19 – DPLL0LDRTO** DPLL0 Loop Divider Ratio Update Complete Interrupt Enable

0: The DPLL0 Loop Divider Ratio Update Complete interrupt is disabled.

1: The DPLL0 Loop Divider Ratio Update Complete interrupt is enabled, and an interrupt request will be generated when the DPLL0 Loop Divider Ratio Update Complete Interrupt flag is set.

Writing a zero to this bit has no effect.

Writing a '1' to this bit will set the DPLL0 Loop Divider Ratio Update Complete Interrupt Enable bit, which enables the DPLL0 Loop Divider Ratio Update Complete interrupt.

**Bit 18 – DPLL0LTO** DPLL0 Lock Timeout Interrupt Enable

0: The DPLL0 Lock Timeout interrupt is disabled.

1: The DPLL0 Lock Timeout interrupt is enabled, and an interrupt request will be generated when the DPLL0 Lock Timeout Interrupt flag is set.

Writing a zero to this bit has no effect.

Writing a '1' to this bit will set the DPLL0 Lock Timeout Interrupt Enable bit, which enables the DPLL0 Lock Timeout interrupt.

**Bit 17 – DPLL0LCKF** DPLL0 Lock Fall Interrupt Enable

0: The DPLL0 Lock Fall interrupt is disabled.

1: The DPLL0 Lock Fall interrupt is enabled, and an interrupt request will be generated when the DPLL0 Lock Fall Interrupt flag is set.

Writing a zero to this bit has no effect.

Writing a '1' to this bit will set the DPLL0 Lock Fall Interrupt Enable bit, which enables the DPLL0 Lock Fall interrupt.

**Bit 16 – DPLL0LCKR** DPLL0 Lock Rise Interrupt Enable

0: The DPLL0 Lock Rise interrupt is disabled.

1: The DPLL0 Lock Rise interrupt is enabled, and an interrupt request will be generated when the DPLL0 Lock Rise Interrupt flag is set.

Writing a zero to this bit has no effect.

Writing a '1' to this bit will set the DPLL0 Lock Rise Interrupt Enable bit, which enables the DPLL0 Lock Rise interrupt.

**Bit 12 – DFLLRCS** DFLL Reference Clock Stopped Interrupt Enable

0: The DFLL Reference Clock Stopped interrupt is disabled.

1: The DFLL Reference Clock Stopped interrupt is enabled, and an interrupt request will be generated when the DFLL Reference Clock Stopped Interrupt flag is set.

Writing a zero to this bit has no effect.

# SAM D5x/E5x Family Data Sheet

## OSCCTRL – Oscillators Controller

---

Writing a '1' to this bit will set the DFLL Reference Clock Stopped Interrupt Enable bit, which enables the DFLL Reference Clock Stopped interrupt.

### **Bit 11 – DFLLCKC** DFLL Lock Coarse Interrupt Enable

0: The DFLL Lock Coarse interrupt is disabled.

1: The DFLL Lock Coarse interrupt is enabled, and an interrupt request will be generated when the DFLL Lock Coarse Interrupt flag is set.

Writing a zero to this bit has no effect.

Writing a '1' to this bit will set the DFLL Lock Coarse Interrupt Enable bit, which enables the DFLL Lock Coarse interrupt.

### **Bit 10 – DFLLCKF** DFLL Lock Fine Interrupt Enable

0: The DFLL Lock Fine interrupt is disabled.

1: The DFLL Lock Fine interrupt is enabled, and an interrupt request will be generated when the DFLL Lock Fine Interrupt flag is set.

Writing a zero to this bit has no effect.

Writing a '1' to this bit will set the DFLL Lock Fine Interrupt Disable/Enable bit, disable the DFLL Lock Fine interrupt and set the corresponding interrupt request.

### **Bit 9 – DFLL0OB** DFLL Out Of Bounds Interrupt Enable

0: The DFLL Out Of Bounds interrupt is disabled.

1: The DFLL Out Of Bounds interrupt is enabled, and an interrupt request will be generated when the DFLL Out Of Bounds Interrupt flag is set.

Writing a zero to this bit has no effect.

Writing a '1' to this bit will set the DFLL Out Of Bounds Interrupt Enable bit, which enables the DFLL Out Of Bounds interrupt.

### **Bit 8 – DFLLRDY** DFLL Ready Interrupt Enable

0: The DFLL Ready interrupt is disabled.

1: The DFLL Ready interrupt is enabled, and an interrupt request will be generated when the DFLL Ready Interrupt flag is set.

Writing a zero to this bit has no effect.

Writing a '1' to this bit will set the DFLL Ready Interrupt Enable bit, which enables the DFLL Ready interrupt.

### **Bits 2, 3 – XOSCFAIL** XOSCn Clock Failure Interrupt Enable

0: The XOSCn Clock Failure interrupt is disabled.

1: The XOSCn Clock Failure interrupt is enabled, and an interrupt request will be generated when the XOSCn Clock Failure Interrupt flag is set.

Writing a zero to this bit has no effect.

Writing a '1' to this bit will set the XOSCn Clock Failure Interrupt Enable bit, which enables the XOSCn Clock Failure interrupt.

### **Bits 0, 1 – XOSCRDY** XOSCn Ready Interrupt Enable

0: The XOSCn Ready interrupt is disabled.

1: The XOSCn Ready interrupt is enabled, and an interrupt request will be generated when the XOSC0 Ready Interrupt flag is set.

Writing a zero to this bit has no effect.

Writing a '1' to this bit will set the XOSCn Ready Interrupt Enable bit, which enables the XOSCn Ready interrupt.

# SAM D5x/E5x Family Data Sheet

## OSCCTRL – Oscillators Controller

### 28.8.4 Interrupt Flag Status and Clear

**Name:** INTFLAG  
**Offset:** 0x0C  
**Reset:** 0x00000000

Bit	31	30	29	28	27	26	25	24
					DPLL1LDRTO	DPLL1LTO	DPLL1LCKF	DPLL1LCKR
Access					R/W	R/W	R/W	R/W
Reset					0	0	0	0
Bit	23	22	21	20	19	18	17	16
					DPLL0LDRTO	DPLL0LTO	DPLL0LCKF	DPLL0LCKR
Access					R/W	R/W	R/W	R/W
Reset					0	0	0	0
Bit	15	14	13	12	11	10	9	8
				DFLLRCS	DFLLLCKC	DFLLLCKF	DFLLOOB	DFLLRDY
Access				R/W	R/W	R/W	R/W	R/W
Reset				0	0	0	0	0
Bit	7	6	5	4	3	2	1	0
						XOSCFAIL	XOSCRDY1	XOSCRDY0
Access						R/W	R/W	R/W
Reset						0	0	0

**Bit 27 – DPLL1LDRTO** DPLL1 Loop Divider Ratio Update Complete

This flag is cleared by writing a '1' to it.

This flag is set on a zero-to-one transition of the DPLL1 Loop Divider Ratio Update Complete bit in the Status register (STATUS.DPLL1LDRTO) and will generate an interrupt request if INTENSET.DPLL1LDRTO is '1'.

Writing a zero to this bit has no effect.

Writing a '1' to this bit clears the DPLL1 Loop Divider Ratio Update Complete interrupt flag.

**Bit 26 – DPLL1LTO** DPLL1 Lock Timeout

This flag is cleared by writing a '1' to it.

This flag is set on a zero-to-one transition of the DPLL1 Lock Timeout bit in the Status register (STATUS.DPLL1LTO) and will generate an interrupt request if INTENSET.DPLL1LTO is '1'.

Writing a zero to this bit has no effect.

Writing a '1' to this bit clears the DPLL1 Lock Timeout interrupt flag.

**Bit 25 – DPLL1LCKF** DPLL1 Lock Fall

This flag is cleared by writing a '1' to it.

This flag is set on a zero-to-one transition of the DPLL1 Lock Fall bit in the Status register (STATUS.DPLL1LCKF) and will generate an interrupt request if INTENSET.DPLL1LCKF is '1'.

Writing a zero to this bit has no effect.

Writing a '1' to this bit clears the DPLL1 Lock Fall interrupt flag.

**Bit 24 – DPLL1LCKR** DPLL1 Lock Rise

This flag is cleared by writing a '1' to it.

This flag is set on a zero-to-one transition of the DPLL1 Lock Rise bit in the Status register (STATUS.DPLL1LCKR) and will generate an interrupt request if INTENSET.DPLL1LCKR is '1'.

Writing a zero to this bit has no effect.

Writing a '1' to this bit clears the DPLL1 Lock Rise interrupt flag.

**Bit 19 – DPLL0LDRTO** DPLL0 Loop Divider Ratio Update Complete

This flag is cleared by writing a '1' to it.

This flag is set on a zero-to-one transition of the DPLL0 Loop Divider Ratio Update Complete bit in the Status register (STATUS.DPLL0LDRTO) and will generate an interrupt request if INTENSET.DPLL0LDRTO is '1'.

Writing a zero to this bit has no effect.

Writing a '1' to this bit clears the DPLL0 Loop Divider Ratio Update Complete interrupt flag.

**Bit 18 – DPLL0LTO** DPLL0 Lock Timeout

This flag is cleared by writing a '1' to it.

This flag is set on a zero-to-one transition of the DPLL0 Lock Timeout bit in the Status register (STATUS.DPLL0LTO) and will generate an interrupt request if INTENSET.DPLL0LTO is '1'.

Writing a zero to this bit has no effect.

Writing a '1' to this bit clears the DPLL0 Lock Timeout interrupt flag.

**Bit 17 – DPLL0LCKF** DPLL0 Lock Fall

This flag is cleared by writing a '1' to it.

This flag is set on a zero-to-one transition of the DPLL0 Lock Fall bit in the Status register (STATUS.DPLL0LCKF) and will generate an interrupt request if INTENSET.DPLL0LCKF is '1'.

Writing a zero to this bit has no effect.

Writing a '1' to this bit clears the DPLL0 Lock Fall interrupt flag.

**Bit 16 – DPLL0LCKR** DPLL0 Lock Rise

This flag is cleared by writing a '1' to it.

This flag is set on a zero-to-one transition of the DPLL0 Lock Rise bit in the Status register (STATUS.DPLL0LCKR) and will generate an interrupt request if INTENSET.DPLL0LCKR is '1'.

Writing a zero to this bit has no effect.

Writing a '1' to this bit clears the DPLL0 Lock Rise interrupt flag.

**Bit 12 – DFLLRCS** DFLL Reference Clock Stopped

This flag is cleared by writing a '1' to it.

This flag is set on a zero-to-one transition of the DFLL Reference Clock Stopped bit in the Status register (STATUS.DFLLRCS) and will generate an interrupt request if INTENSET.DFLLRCS is '1'.

Writing a zero to this bit has no effect.

Writing a '1' to this bit clears the DFLL Reference Clock Stopped interrupt flag.

**Bit 11 – DFLLCKC** DFLL Lock Coarse

This flag is cleared by writing a '1' to it.

This flag is set on a zero-to-one transition of the DFLL Lock Coarse bit in the Status register (STATUS.DFLLCKC) and will generate an interrupt request if INTENSET.DFLLCKC is '1'.

Writing a zero to this bit has no effect.

Writing a '1' to this bit clears the DFLL Lock Coarse interrupt flag.

**Bit 10 – DFLLCKF** DFLL Lock Fine

This flag is cleared by writing a '1' to it.

This flag is set on a zero-to-one transition of the DFLL Lock Fine bit in the Status register (STATUS.DFLLCKF) and will generate an interrupt request if INTENSET.DFLLCKF is '1'.

Writing a zero to this bit has no effect.

Writing a '1' to this bit clears the DFLL Lock Fine interrupt flag.

**Bit 9 – DFLLLOB** DFLL Out Of Bounds

This flag is cleared by writing a '1' to it.

This flag is set on a zero-to-one transition of the DFLL Out Of Bounds bit in the Status register (STATUS.DFLLLOB) and will generate an interrupt request if INTENSET.DFLLLOB is '1'.

Writing a zero to this bit has no effect.

Writing a '1' to this bit clears the DFLL Out Of Bounds interrupt flag.

**Bit 8 – DFLLRDY** DFLL Ready

This flag is cleared by writing a '1' to it.

This flag is set on a zero-to-one transition of the DFLL Ready bit in the Status register (STATUS.DFLLRDY) and will generate an interrupt request if INTENSET.DFLLRDY is '1'.

Writing a zero to this bit has no effect.

Writing a '1' to this bit clears the DFLL Ready interrupt flag.

**Bit 2 – XOSCFAIL** XOSCn Clock Failure

This flag is cleared by writing a '1' to it.

This flag is set on a zero-to-one transition of the XOSCn Clock Failure bit in the Status register (STATUS.XOSCFAILn) and will generate an interrupt request if INTENSET.XOSCFAILn is '1'.

Writing a zero to this bit has no effect.

Writing a '1' to this bit clears the XOSCn Clock Failure interrupt flag.

**Bits 0, 1 – XOSCRDY** XOSCn Ready

This flag is cleared by writing a '1' to it.

This flag is set on a zero-to-one transition of the XOSC0 Ready bit in the Status register (STATUS.XOSCRDYn) and will generate an interrupt request if INTENSET.XOSCRDYn is '1'.

Writing a zero to this bit has no effect.

Writing a '1' to this bit clears the XOSCn Ready interrupt flag.

# SAM D5x/E5x Family Data Sheet

## OSCCTRL – Oscillators Controller

### 28.8.5 Status

**Name:** STATUS  
**Offset:** 0x10  
**Reset:** 0x00000000

	Bit	31	30	29	28	27	26	25	24
						DPLL1LDRTO	DPLL1TO	DPLL1LCKF	DPLL1LCKR
Access						R	R	R	R
Reset						0	0	0	0
	Bit	23	22	21	20	19	18	17	16
						DPLL0LDRTO	DPLL0TO	DPLL0LCKF	DPLL0LCKR
Access						R	R	R	R
Reset						0	0	0	0
	Bit	15	14	13	12	11	10	9	8
					DFLLRCS	DFLLCKC	DFLLCKF	DFLLOOB	DFLLRDY
Access					R	R	R	R	R
Reset					0	0	0	0	0
	Bit	7	6	5	4	3	2	1	0
				XOSCCKSW1	XOSCCKSW0	XOSCFAIL1	XOSCFAIL0	XOSCRDY1	XOSCRDY0
Access				R	R	R	R	R	R/W
Reset				0	0	0	0	0	0

**Bit 27 – DPLL1LDRTO** DPLL1 Loop Divider Ratio Update Complete

0: DPLL1 Loop Divider Ratio Update Complete not detected.

1: DPLL1 Loop Divider Ratio Update Complete detected.

**Bit 26 – DPLL1TO** DPLL1 Lock Timeout

0: DPLL1 Lock time-out not detected.

1: DPLL1 Lock time-out detected.

**Bit 25 – DPLL1LCKF** DPLL1 Lock Fall

0: DPLL1 Lock fall edge not detected.

1: DPLL1 Lock fall edge detected.

**Bit 24 – DPLL1LCKR** DPLL1 Lock Rise

0: DPLL1 Lock rise edge not detected.

1: DPLL1 Lock rise edge detected.

**Bit 19 – DPLL0LDRTO** DPLL0 Loop Divider Ratio Update Complete

0: DPLL0 Loop Divider Ratio Update Complete not detected.

1: DPLL0 Loop Divider Ratio Update Complete detected.

**Bit 18 – DPLL0TO** DPLL0 Lock Timeout

0: DPLL0 Lock time-out not detected.

1: DPLL0 Lock time-out detected.



**Bit 17 – DPLL0LCKF** DPLL0 Lock Fall

0: DPLL0 Lock fall edge not detected.

1: DPLL0 Lock fall edge detected.

**Bit 16 – DPLL0LCKR** DPLL0 Lock Rise

0: DPLL0 Lock rise edge not detected.

1: DPLL0 Lock rise edge detected.

**Bit 12 – DFLLRCS** DFLL Reference Clock Stopped

0: DFLL reference clock is running.

1: DFLL reference clock has stopped.

**Bit 11 – DFLLLCKC** DFLL Lock Coarse

0: No DFLL coarse lock detected.

1: DFLL coarse lock detected.

**Bit 10 – DFLLLCKF** DFLL Lock Fine

0: No DFLL fine lock detected.

1: DFLL fine lock detected.

**Bit 9 – DFLLOOB** DFLL Out Of Bounds

0: No DFLL Out Of Bounds detected.

1: DFLL Out Of Bounds detected.

**Bit 8 – DFLLRDY** DFLL Ready

0: DFLL is not ready.

1: DFLL is stable and ready to be used as a clock source.

**Bit 5 – XOSCCKSW1** XOSC1 Clock Switch

0: XOSC1 is not switched and provides the external clock or crystal oscillator clock.

1: XOSC is switched and provides the safe clock.

**Bit 4 – XOSCCKSW0** XOSC0 Clock Switch

0: XOSC0 is not switched and provides the external clock or crystal oscillator clock.

1: XOSC0 is switched and provides the safe clock.

**Bit 3 – XOSCFAIL1** XOSC1 Clock Failure

0: XOSC1 failure not detected.

1: XOSC1 failure detected.

**Bit 2 – XOSCFAIL0** XOSC0 Clock Failure

0: XOSC0 failure not detected.

1: XOSC0 failure detected.

**Bit 1 – XOSCRDY1** XOSC1 Ready

0: XOSC1 is not ready.

1: XOSC1 is stable and ready to be used as a clock source.

**Bit 0 – XOSCRDY0** XOSC0 Ready

0: XOSC0 is not ready.

# SAM D5x/E5x Family Data Sheet

## OSCCTRL – Oscillators Controller

---

---

1: XOSC0 is stable and ready to be used as a clock source.

# SAM D5x/E5x Family Data Sheet

## OSCCTRL – Oscillators Controller

### 28.8.6 External Multipurpose Crystal Oscillator Control

**Name:** XOSCCTRL  
**Offset:** 0x14 + n\*0x04 [n=0..1]  
**Reset:** 0x00000080  
**Property:** PAC Write-Protection

	Bit	31	30	29	28	27	26	25	24
		CFDPRESC[3:0]							
Access						R/W	R/W	R/W	R/W
Reset						0	0	0	0
	Bit	23	22	21	20	19	18	17	16
		STARTUP[3:0]						SWBEN	CFDEN
Access		R/W	R/W	R/W	R/W			R/W	R/W
Reset		0	0	0	0			0	0
	Bit	15	14	13	12	11	10	9	8
		ENALC	IMULT[3:0]				IPTAT[1:0]		LOWBUFGAIN
Access		R/W	R/W	R/W	R/W	R/W	R/W	R/W	R/W
Reset		0	0	0	0	0	0	0	0
	Bit	7	6	5	4	3	2	1	0
		ONDEMAND	RUNSTDBY				XTALEN	ENABLE	
Access		R/W	R/W				R/W	R/W	
Reset		1	0				0	0	

#### Bits 27:24 – CFDPRESC[3:0] Clock Failure Detector Prescaler

These bits select the prescaler for the clock failure detector.

The DFLL48 oscillator is used to clock the CFD prescaler.

The CFD safe clock frequency is the DFLL48 frequency divided by  $2^{CFDPRESC}$ .

#### Bits 23:20 – STARTUP[3:0] Start-Up Time

These bits select start-up time for the oscillator XOSC<sub>n</sub> according to the table below.

The OSCULP32K oscillator is used to clock the start-up counter.

**Table 28-6. Start-UpTime for External Multipurpose Crystal Oscillator**

STARTUP[3:0]	Number of OSCULP32K Clock Cycles	Number of XOSC Clock Cycles	Approximate Equivalent Time(
0x0	1	3	31µs
0x1	2	3	61µs
0x2	4	3	122µs
0x3	8	3	244µs
0x4	16	3	488µs
0x5	32	3	977µs

# SAM D5x/E5x Family Data Sheet

## OSCCTRL – Oscillators Controller

.....continued

STARTUP[3:0]	Number of OSCULP32K Clock Cycles	Number of XOSC Clock Cycles	Approximate Equivalent Time(
0x6	64	3	1953μs
0x7	128	3	3906μs
0x8	256	3	7813μs
0x9	512	3	15625μs
0xA	1024	3	31250μs
0xB	2048	3	62500μs
0xC	4096	3	125000μs
0xD	8192	3	250000μs
0xE	16384	3	500000μs
0xF	32768	3	1000000μs

### Bit 17 – SWBEN Xosc Clock Switch Enable

This bit controls the XOSCn output clock switch back to the external clock or crystal oscillator in case of clock recovery :

0: The clock switch back is disabled.

1: The clock switch back is enabled. This bit is reset once the XOSCn output clock is switched back to the external clock or crystal oscillator.

### Bit 16 – CFDEN Clock Failure Detector Enable

This bit controls the XOSCn clock failure detector :

0: the Clock Failure Detector is disabled.

1: the Clock Failure Detector is enabled.

### Bit 15 – ENALC Automatic Loop Control Enable

This bit controls the XOSCn automatic loop control :

0: the automatic loop control is disabled.

1: the automatic loop control is enabled. Oscillator's amplitude will be automatically adjusted during Crystal Oscillator operation.

### Bits 14:11 – IMULT[3:0] Oscillator Current Multiplier

These bits select the current multiplier for the oscillator XOSCn, given in table [External Multipurpose Crystal Oscillator Current Settings](#).

### Bits 10:9 – IPTAT[1:0] Oscillator Current Reference

These bits select the current reference for the oscillator XOSCn, given in table below.

# SAM D5x/E5x Family Data Sheet

## OSCCTRL – Oscillators Controller

**Table 28-7. External Multipurpose Crystal Oscillator Current Settings**

Frequency Range	Current Setting	
	IMULT[3:0]	IPTAT[1:0]
24MHz to 48MHz	6	3
16MHz to 24MHz	5	3
8MHz to 16MHz	4	3
8MHz	3	2

For relatively small CLOAD in a frequency range, the setting for the lower frequency range can be used to preserve current consumption.

**Bit 8 – LOWBUFGAIN** Low Buffer Gain Enable

0: The low buffer gain of oscillator XOSCn is disabled.

1: The low buffer gain of oscillator XOSCn is enabled.

When XOSCCTRLn.ENALC=0 this bit has no effect.

When XOSCCTRLn.ENALC=1, this bit is used to adjust the oscillator's amplitude in automatic loop control.

The default value of LOWBUFGAIN=0 should be used to allow operating with a low amplitude oscillator.

Use this setting except to solve stability issues.

Setting LOWBUFGAIN=1 will increase the oscillator's amplitude by a factor of approximately 2. Use this setting to solve stability issues.

**Bit 7 – ONDEMAND** On Demand Control

The On Demand operation mode allows the oscillator XOSCn to be enabled or disabled, depending on peripheral clock requests.

If On Demand is set, the oscillator will be running only when requested by a peripheral and enabled (XOSCCTRLn.ENABLE=1). If there is no peripheral requesting the oscillator's clock source, the oscillator will be in a disabled state.

If On Demand is cleared, the oscillator will always be running when enabled (XOSCCTRLn.ENABLE=1).

In standby sleep mode, the On Demand operation is still active.

0: The oscillator is always on.

1: The oscillator is running when a peripheral is requesting the oscillator to be used as a clock source.

The oscillator is not running if no peripheral is requesting the clock source.

**Bit 6 – RUNSTDBY** Run in Standby

This bit controls how the XOSCn behaves during standby sleep mode:

0: The XOSCn is not running in standby sleep mode if no peripheral requests the clock.

1: The XOSCn is running in standby sleep mode. If ONDEMAND is one, the XOSCn will be running when a peripheral is requesting the clock. If ONDEMAND is zero, the clock source will always be running in standby sleep mode.

**Bit 2 – XTALEN** Crystal Oscillator Enable

This bit controls the connections between the I/O pads and the external clock or crystal oscillator XOSCn:

0: External clock connected on XIN. XOUT can be used as general-purpose I/O.

1: Crystal connected to XIN/XOUT.

# SAM D5x/E5x Family Data Sheet

## OSCCTRL – Oscillators Controller

---

**Bit 1 – ENABLE** Oscillator Enable

0: The oscillator XOSCn is disabled.

1: The oscillator XOSCn is enabled.

# SAM D5x/E5x Family Data Sheet

## OSCCTRL – Oscillators Controller

### 28.8.7 DFLL48M Control A

**Name:** DFLLCTRLA  
**Offset:** 0x1C  
**Reset:** 0x82  
**Property:** PAC Write-Protection

	7	6	5	4	3	2	1	0
	ONDEMAND	RUNSTDBY					ENABLE	
Access	R/W	R/W					R/W	
Reset	1	0					1	

**Bit 7 – ONDEMAND** On Demand Control

The On Demand operation mode allows the DFLL to be enabled or disabled depending on peripheral clock requests.

If On Demand is set, the DFLL will only be running when requested by a peripheral and enabled (DFLLTRLA.ENABLE=1). If there is no peripheral requesting the DFLL's clock source, the DFLL will be in a disabled state.

If On Demand is disabled the DFLL will always be running when enabled (DFLLTRLA.ENABLE=1). In standby sleep mode, the On Demand operation is still active.

0: The DFLL is always on.

1: The DFLL is running when a peripheral is requesting the DFLL to be used as a clock source. The DFLL is not running if no peripheral is requesting the clock source.

**Bit 6 – RUNSTDBY** Run in Standby

This bit controls how the DFLL behaves during standby sleep mode:

0: The DFLL is not running in standby sleep mode if no peripheral requests the clock.

1: The DFLL is running in standby sleep mode. If ONDEMAND is one, the DFLL will be running when a peripheral is requesting the clock. If ONDEMAND is zero, the clock source will always be running in standby sleep mode.

**Bit 1 – ENABLE** DFLL Enable

0: The DFLL oscillator is disabled.

1: The DFLL oscillator is enabled.

**Note:** This bit is write-synchronized: Due to synchronization, there is delay from updating the register until the peripheral is enabled/disabled. The value written to DFLLCTRLA.ENABLE will read back immediately after written.

### 28.8.8 DFLL48M Control B

**Name:** DFLLCTRLB  
**Offset:** 0x20  
**Reset:** 0x00  
**Property:** Read-Synchronized

Bit	7	6	5	4	3	2	1	0
	WAITLOCK	BPLCKC	QLDIS	CCDIS	USBCRM	LLAW	STABLE	MODE
Access	R/W	R/W	R/W	R/W	R/W	R/W	R/W	R/W
Reset	0	0	0	0	0	0	0	0

**Bit 7 – WAITLOCK** Wait Lock

This bit controls the DFLL output clock, depending on lock status:

- 0: Output clock before the DFLL is locked.
- 1: Output clock when DFLL is locked (Fine lock).

**Bit 6 – BPLCKC** Bypass Coarse Lock

This bit controls the coarse lock procedure:

- 0: Bypass coarse lock is disabled.
- 1: Bypass coarse lock is enabled.

**Bit 5 – QLDIS** Quick Lock Disable

- 0: Quick Lock is enabled.
- 1: Quick Lock is disabled.

**Bit 4 – CCDIS** Chill Cycle Disable

- 0: Chill Cycle is enabled.
- 1: Chill Cycle is disabled.

**Bit 3 – USBCRM** USB Clock Recovery Mode

- 0: USB Clock Recovery Mode is disabled.
- 1: USB Clock Recovery Mode is enabled.

**Bit 2 – LLAW** Lose Lock After Wake

- 0: Locks will not be lost after waking up from sleep modes if the DFLL clock has been stopped.
- 1: Locks will be lost after waking up from sleep modes if the DFLL clock has been stopped.

**Bit 1 – STABLE** Stable DFLL Frequency

- 0: FINE calibration tracks changes in output frequency.
- 1: FINE calibration register value will be fixed after a fine lock.

**Bit 0 – MODE** Operating Mode Selection

- 0: The DFLL operates in open-loop operation.
- 1: The DFLL operates in closed-loop operation.



# SAM D5x/E5x Family Data Sheet

## OSCCTRL – Oscillators Controller

### 28.8.9 DFLL48M Value

**Name:** DFLLVAL  
**Offset:** 0x24  
**Reset:** 0x0000XXXX  
**Property:** PAC Write-Protection, Read-Synchronized, Write-Synchronized

	Bit	31	30	29	28	27	26	25	24	
		DIFF[15:8]								
Access		R	R	R	R	R	R	R	R	
Reset		0	0	0	0	0	0	0	0	
	Bit	23	22	21	20	19	18	17	16	
		DIFF[7:0]								
Access		R	R	R	R	R	R	R	R	
Reset		0	0	0	0	0	0	0	x	
	Bit	15	14	13	12	11	10	9	8	
		COARSE[5:0]								
Access		R/W	R/W	R/W	R/W	R/W	R/W			
Reset		0	0	0	0	0	x			
	Bit	7	6	5	4	3	2	1	0	
		FINE[7:0]								
Access		R/W	R/W	R/W	R/W	R/W	R/W	R/W	R/W	
Reset		0	0	0	0	0	0	0	x	

**Bits 31:16 – DIFF[15:0]** Multiplication Ratio Difference

In closed-loop mode (DFLLCTRLB.MODE is written to one), this bit group indicates the difference between the ideal number of DFLL cycles and the counted number of cycles. This value is not updated in open-loop mode, and should be considered invalid in that case.

**Bits 15:10 – COARSE[5:0]** Coarse Value

Set the value of the Coarse Calibration register. In closed-loop mode, this field is read-only. The DFLL48M is factory-calibrated for 48MHz. Register DFLLVAL.COARSE stores the coarse frequency calibration after reset.

**Bits 7:0 – FINE[7:0]** Fine Value

Set the value of the Fine Calibration register. In closed-loop mode, this field is read-only. The DFLL48M is factory-calibrated for 48MHz. Register DFLLVAL.FINE stores the coarse frequency calibration after reset.

# SAM D5x/E5x Family Data Sheet

## OSCCTRL – Oscillators Controller

### 28.8.10 DFLL48M Multiplier

**Name:** DFLLMUL  
**Offset:** 0x28  
**Reset:** 0x00000000  
**Property:** PAC Write-Protection, Write-Synchronized

	Bit	31	30	29	28	27	26	25	24
		CSTEP[5:0]							
Access		R/W	R/W	R/W	R/W	R/W	R/W		
Reset		0	0	0	0	0	0		
	Bit	23	22	21	20	19	18	17	16
		FSTEP[7:0]							
Access		R/W	R/W	R/W	R/W	R/W	R/W	R/W	R/W
Reset		0	0	0	0	0	0	0	0
	Bit	15	14	13	12	11	10	9	8
		MUL[15:8]							
Access		R/W	R/W	R/W	R/W	R/W	R/W	R/W	R/W
Reset		0	0	0	0	0	0	0	0
	Bit	7	6	5	4	3	2	1	0
		MUL[7:0]							
Access		R/W	R/W	R/W	R/W	R/W	R/W	R/W	R/W
Reset		0	0	0	0	0	0	0	0

**Bits 31:26 – CSTEP[5:0] Coarse Maximum Step**

This bit group indicates the maximum step size allowed during coarse adjustment in closed-loop mode. When adjusting to a new frequency, the expected output frequency overshoot depends on this step size.

**Bits 23:16 – FSTEP[7:0] Fine Maximum Step**

This bit group indicates the maximum step size allowed during fine adjustment in closed-loop mode. When adjusting to a new frequency, the expected output frequency overshoot depends on this step size.

**Bits 15:0 – MUL[15:0] DFLL Multiply Factor**

This field determines the ratio of the CLK\_DFLL output frequency to the CLK\_DFLL\_REF input frequency. Writing to the MUL bits will cause locks to be lost and the fine calibration value to be reset to its midpoint.

### 28.8.11 DFLL48M Synchronization

**Name:** DFLLSYNC  
**Offset:** 0x2C  
**Reset:** 0x00

	7	6	5	4	3	2	1	0
Bit				DFLLMUL	DFLLVAL	DFLLCTRLB	ENABLE	
Access				R	R	R	R	
Reset				0	0	0	0	

**Bit 4 – DFLLMUL** DFLLMUL Synchronization Busy

This bit is cleared when the synchronization of DFLLMUL register between the clock domains is complete.

This bit is set when the synchronization of DFLLMUL register between clock domains is started. The DFLLMUL synchronization only applies for write operations.

**Bit 3 – DFLLVAL** DFLLVAL Synchronization Busy

This bit is cleared when the synchronization of DFLLVAL register between the clock domains is complete.

This bit is set when the synchronization of DFLLVAL register between clock domains is started. The DFLLVAL synchronization applies for read and write operations.

**Bit 2 – DFLLCTRLB** DFLLCTRLB Synchronization Busy

This bit is cleared when the synchronization of DFLLCTRLB register between the clock domains is complete.

This bit is set when the synchronization of DFLLCTRLB register between clock domains is started. The DFLLCTRLB synchronization only applies for write operations.

**Bit 1 – ENABLE** ENABLE Synchronization Busy

This bit is cleared when the synchronization of ENABLE register bit between the clock domains is complete.

This bit is set when the synchronization of ENABLE register bit between clock domains is started.

### 28.8.12 DPLL Control A

**Name:** DPLLCTRLA  
**Offset:** 0x30 + n\*0x14 [n=0..1]  
**Reset:** 0x80  
**Property:** PAC Write-Protection, Write-Synchronized(ENABLE), Enable-Protected (ONDEMAND, RUNSTDBY)

	7	6	5	4	3	2	1	0
	ONDEMAND	RUNSTDBY					ENABLE	
Access	R/W	R/W					R/W	
Reset	1	0					0	

**Bit 7 – ONDEMAND** On Demand Control

The On Demand operation mode allows the DPLLn to be enabled or disabled, depending on peripheral clock requests.

If On Demand is set, the DPLLn will be running only when requested by a peripheral and enabled (DPLLnCTRLA.ENABLE=1). If there is no peripheral requesting the DPLLn's clock source, the DPLLn will be in a disabled state.

If On Demand is cleared, the DPLLn will always be running when enabled (DPLLnCTRLA.ENABLE=1). In standby sleep mode, the On Demand operation is still active.

0: The DPLLn is always running.

1: The DPLLn is running when a peripheral is requesting the DPLLn to be used as a clock source. The DPLLn is not running if no peripheral is requesting the clock source.

**Bit 6 – RUNSTDBY** Run in Standby

This bit controls how the DPLLn behaves during standby sleep mode:

0: The DPLLn is not running in standby sleep mode if no peripheral requests the clock.

1: The DPLLn is running in standby sleep mode. If ONDEMAND is one, the DPLLn will be running when a peripheral is requesting the clock. If ONDEMAND is zero, the clock source will always be running in standby sleep mode.

**Bit 1 – ENABLE** DPLL Enable

0: The DPLLn is disabled.

1: The DPLLn is enabled.

The software operation of enabling or disabling the DPLLn takes a few clock cycles, so the DPLLnSYNCBUSY.ENABLE status bit indicates when the DPLLn is successfully enabled or disabled.

# SAM D5x/E5x Family Data Sheet

## OSCCTRL – Oscillators Controller

### 28.8.13 DPLL Ratio Control

**Name:** DPLL\_RATIO  
**Offset:** 0x34 + n\*0x14 [n=0..1]  
**Reset:** 0x00000000  
**Property:** PAC Write-Protection, Write-Synchronized

Refer to the Synchronization section in the Clock System Overview chapter for details on the functionality of this register.

Bit	31	30	29	28	27	26	25	24
Access								
Reset								
Bit	23	22	21	20	19	18	17	16
				LDRFRAC[4:0]				
Access				R/W	R/W	R/W	R/W	R/W
Reset				0	0	0	0	0
Bit	15	14	13	12	11	10	9	8
				LDR[12:8]				
Access				R/W	R/W	R/W	R/W	R/W
Reset				0	0	0	0	0
Bit	7	6	5	4	3	2	1	0
	LDR[7:0]							
Access	R/W	R/W	R/W	R/W	R/W	R/W	R/W	R/W
Reset	0	0	0	0	0	0	0	0

**Bits 20:16 – LDRFRAC[4:0]** Loop Divider Ratio Fractional Part

Write these bits to set the fractional part of the frequency multiplier. Due to synchronization there is a delay between writing to DPLLnRATIO.LDRFRAC[4:0] and the effect on the DPLLn output clock. The value written DPLLnRATIO.LDRFRAC[4:0] will be read back immediately and the DPLL\_RATIO bit in the synchronization busy register, DPLLnSYNDBUSY.DPLL\_RATIO, will be set. DPLLnSYNDBUSY.DPLL\_RATIO will be cleared when the operation is completed.

**Bits 12:0 – LDR[12:0]** Loop Divider Ratio

Write these bits to set the integer part of the frequency multiplier. The value written DPLLnRATIO.LDR[3:0] will be read back immediately and the DPLL\_RATIO bit in the synchronization busy register, DPLLnSYNDBUSY.DPLL\_RATIO, will be set. DPLLnSYNDBUSY.DPLL\_RATIO will be cleared when the operation is completed.

# SAM D5x/E5x Family Data Sheet

## OSCCTRL – Oscillators Controller

### 28.8.14 DPLL Control B

**Name:** DPLLCTRLB  
**Offset:** 0x38 + n\*0x14 [n=0..1]  
**Reset:** 0x00000020  
**Property:** PAC Write-Protection, Enable-Protected

	Bit	31	30	29	28	27	26	25	24
								DIV[10:8]	
Access							R/W	R/W	R/W
Reset							0	0	0
	Bit	23	22	21	20	19	18	17	16
		DIV[7:0]							
Access		R/W	R/W	R/W	R/W	R/W	R/W	R/W	R/W
Reset		0	0	0	0	0	0	0	0
	Bit	15	14	13	12	11	10	9	8
		DCOEN	DCOFILTER[2:0]			LBYPASS	LTIME[2:0]		
Access		R/W	R/W	R/W	R/W	R/W	R/W	R/W	R/W
Reset		0	0	0	0	0	0	0	0
	Bit	7	6	5	4	3	2	1	0
		REFCLK[2:0]			WUF	FILTER[3:0]			
Access		R/W	R/W	R/W	R/W	R/W	R/W	R/W	R/W
Reset		0	0	1	0	0	0	0	0

#### Bits 26:16 – DIV[10:0] Clock Divider

These bits are used to set the XOSC clock division factor and can be calculated with following formula:

$$f_{DIV} = \frac{f_{XOSC}}{2 \times (DIV + 1)}$$

#### Bit 15 – DCOEN DCO Filter Enable

0: Disable DCO filter controller. Sigma-Delta DAC is automatically set the PLL itself.

1: Enable DCO filter controller. DCOFILTER[2:0] is used to select sigma-delta DAC filter bandwidth.

#### Bits 14:12 – DCOFILTER[2:0] Sigma-Delta DCO Filter Selection

These bits select the DPLLn sigma-delta DCO filter type, as shown in the table below:

**Table 28-8. Sigma-delta DCO Filter selection**

DCOFILTER[2:0]	Capacitor (pF)	Bandwidth Fn (MHz)
0x0	0.5	3.21
0x1	1	1.6
0x2	1.5	1.1
0x3	2	0.8
0x4	2.5	0.64

# SAM D5x/E5x Family Data Sheet

## OSCCTRL – Oscillators Controller

.....continued

DCOFILTER[2:0]	Capacitor (pF)	Bandwidth Fn (MHz)
0x5	3	0.55
0x6	3.5	0.45
0x7	4	0.4

**Bit 11 – LBYPASS** Lock Bypass

**Bits 10:8 – LTIME[2:0]** Lock Time

Write these bits to select the lock time-out value, as shown in the figure below:

Value	Name	Description
0x0	Default	No time-out. Automatic lock.
0x1	Reserved	
0x2	Reserved	
0x3	Reserved	
0x4	800US	Time-out if no lock within 800 us
0x5	900US	Time-out if no lock within 900 us
0x6	1MS	Time-out if no lock within 1 ms
0x7	1P1MS	Time-out if no lock within 1.1 ms

**Bits 7:5 – REFCLK[2:0]** Reference Clock Selection

Write these bits to select the DPPLLn clock reference, as shown in the table below:

Value	Name	Description
0x0	GCLK	Dedicated GCLK clock reference
0x1	XOSC32	XOSC32K clock reference (default)
0x2	XOSC0	XOSC0 clock reference
0x3	XOSC1	XOSC1 clock reference
Other	-	Reserved

**Bit 4 – WUF** Wake Up Fast

0: DPPLLn clock is output after startup and lock time.

1: DPPLLn clock is output after startup time.

**Bits 3:0 – FILTER[3:0]** Proportional Integral Filter Selection

These bits select the DPPLLn digital filter type, as shown in the table below:

**Table 28-9. Proportional Integral Filter selection**

FILTER[3:0]	PLL Bandwidth (fn)	Damping Factor
0x0	92.7 kHz	0.76
0x1	131 kHz	1.08
0x2	46.4 kHz	0.38
0x3	65.6 kHz	0.54
0x4	131 kHz	0.56
0x5	185 kHz	0.79

# SAM D5x/E5x Family Data Sheet

## OSCCTRL – Oscillators Controller

.....continued

<b>FILTER[3:0]</b>	<b>PLL Bandwidth (fn)</b>	<b>Damping Factor</b>
0x6	65.6 kHz	0.28
0x7	92.7 kHz	0.39
0x8	46.4 kHz	1.49
0x9	65.6 kHz	2.11
0xA	23.2 kHz	0.75
0xB	32.8 kHz	1.06
0xC	65.6 kHz	1.07
0xD	92.7 kHz	1.51
0xE	32.8 kHz	0.53
0xF	46.4 kHz	0.75

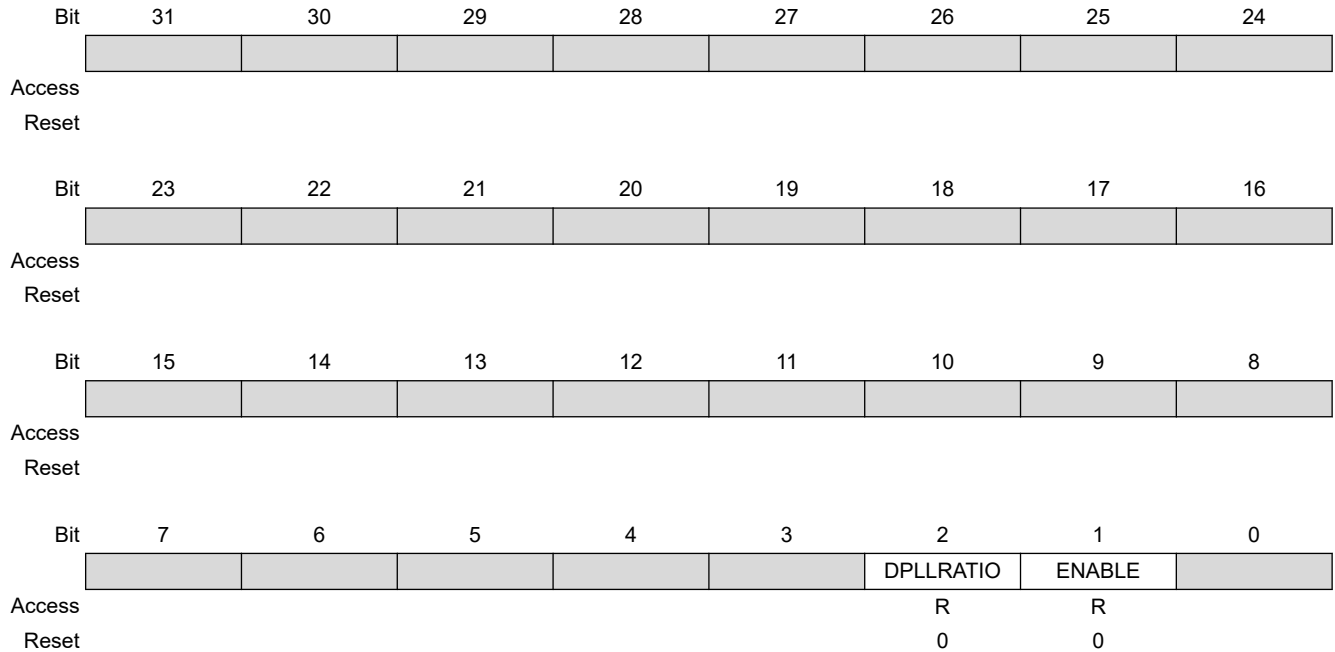


# SAM D5x/E5x Family Data Sheet

## OSCCTRL – Oscillators Controller

### 28.8.15 DPLL Synchronization Busy

**Name:** DPLLSYNCBUSY  
**Offset:** 0x3C + n\*0x14 [n=0..1]  
**Reset:** 0x00000000



**Bit 2 – DPLL RATIO** DPLL Loop Divider Ratio Synchronization Status

0: The DPLL RATIO register has been synchronized.

1: The DPLL RATIO register value has changed and its synchronization is in progress.

**Bit 1 – ENABLE** DPLL Enable Synchronization Status

0: The DPLLnCTRLA.ENABLE bit has been synchronized.

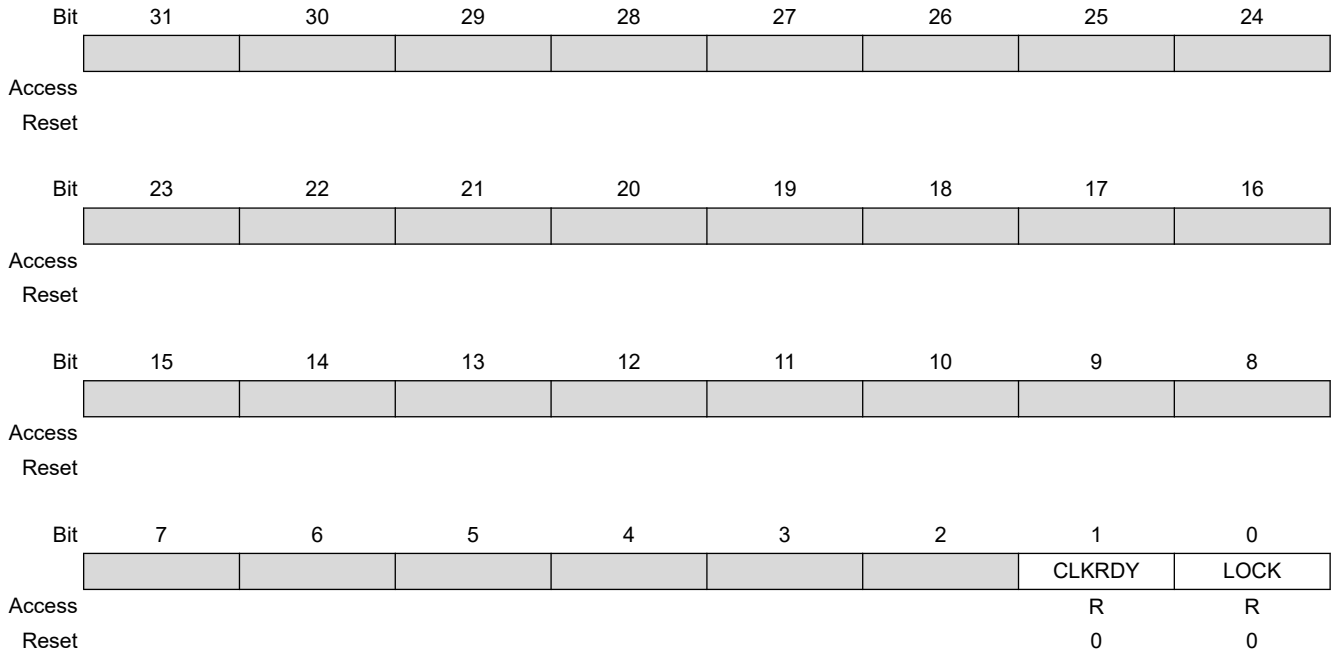
1: The DPLLnCTRLA.ENABLE bit value has changed and its synchronization is in progress.

# SAM D5x/E5x Family Data Sheet

## OSCCTRL – Oscillators Controller

### 28.8.16 DPLL Status

**Name:** DPLLSTATUS  
**Offset:** 0x40 + n\*0x14 [n=0..1]  
**Reset:** 0x00000000



**Bit 1 – CLKRDY** DPLL Clock Ready

0: The DPLLn output clock is off.

1: The DPLLn output clock in on.

**Bit 0 – LOCK** DPLL Lock Status

0: The DPLLn Lock signal is cleared, when the DPLLn is disabled or when the DPLLn is trying to reach the target frequency.

1: The DPLLn Lock signal is asserted when the desired frequency is reached.

## **29. OSC32KCTRL – 32KHz Oscillators Controller**

### **29.1 Overview**

The 32KHz Oscillators Controller (OSC32KCTRL) provides a user interface to the 32.768kHz oscillators: XOSC32K and OSCULP32K.

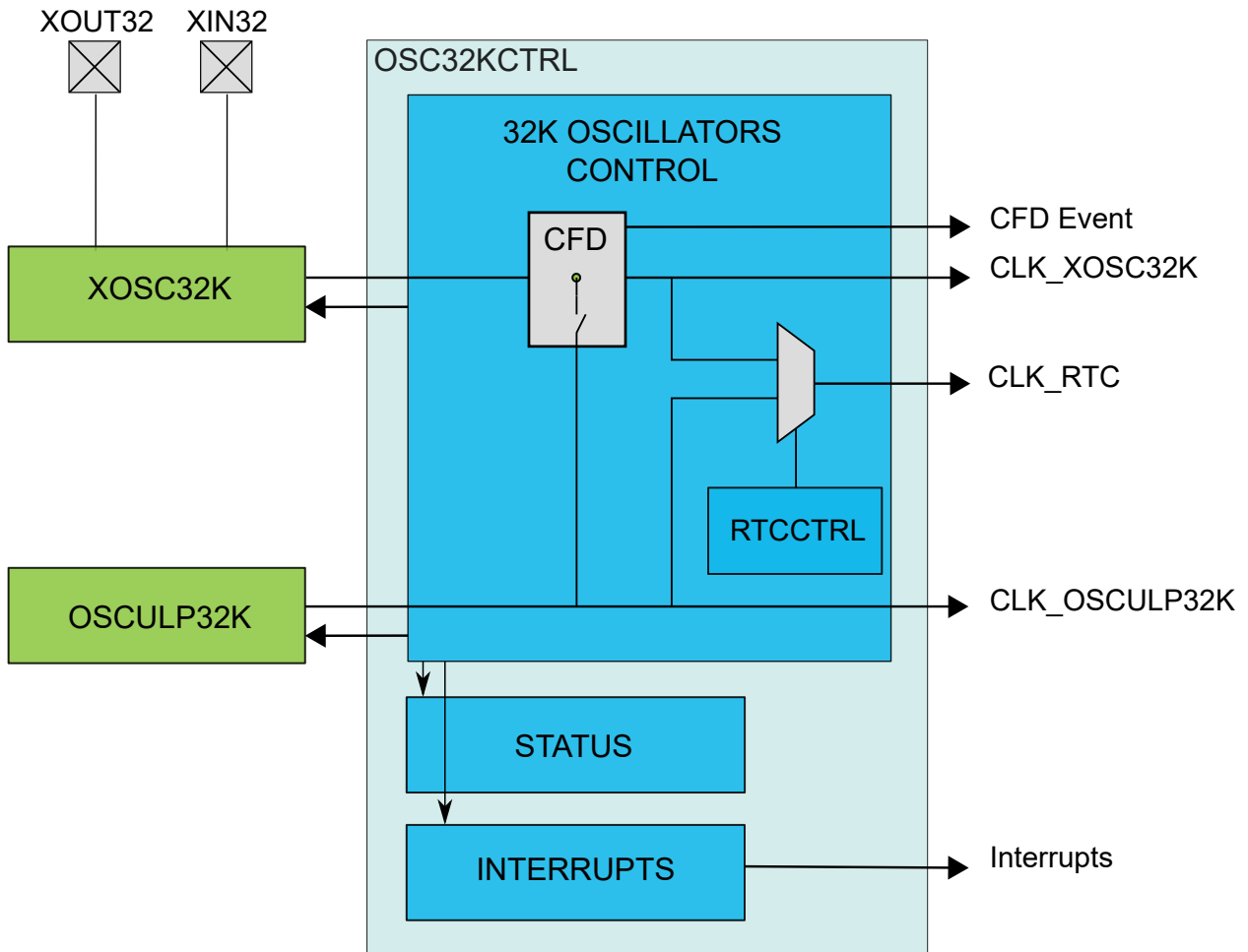
The OSC32KCTRL sub-peripherals can be enabled, disabled, calibrated, and monitored through interface registers.

All sub-peripheral statuses are collected in the Status register (STATUS). They can additionally trigger interrupts upon status changes through the INTENSET, INTENCLR, and INTFLAG registers.

### **29.2 Features**

- 32.768kHz Crystal Oscillator (XOSC32K)
  - Programmable start-up time
  - Crystal or external input clock on XIN32 I/O
  - Clock failure detection with safe clock switch
  - Clock failure event output
- 32.768kHz Ultra Low-Power Internal Oscillator (OSCULP32K)
  - Ultra low-power, always-on oscillator
  - Frequency fine tuning
- Calibration value loaded from Flash factory calibration at Reset
- 1.024 kHz clock outputs available

### 29.3 Block Diagram



### 29.4 Signal Description

Signal	Description	Type
XIN32	Analog Input	32.768 kHz Crystal Oscillator or external clock input
XOUT32	Analog Output	32.768 kHz Crystal Oscillator output

The I/O lines are automatically selected when XOSC32K is enabled.

**Note:** The signal of the external crystal oscillator may affect the jitter of neighboring pads.

### 29.5 Product Dependencies

In order to use this peripheral, other parts of the system must be configured correctly, as described below.

#### 29.5.1 I/O Lines

I/O lines are configured by OSC32KCTRL when XOSC32K is enabled, and need no user configuration.

### 29.5.2 Power Management

The OSC32KCTRL will continue to operate in any sleep mode where a 32KHz oscillator is running as source clock. The OSC32KCTRL interrupts can be used to wake up the device from sleep modes.

#### Related Links

[18. PM – Power Manager](#)

### 29.5.3 Clocks

The OSC32KCTRL gathers controls for all 32KHz oscillators and provides clock sources to the Generic Clock Controller (GCLK), Real-Time Counter (RTC), and Watchdog Timer (WDT).

The available clock sources are: XOSC32K and OSCULP32K.

The OSC32KCTRL bus clock (CLK\_OSC32KCTRL\_APB) can be enabled and disabled in the Main Clock module (MCLK).

### 29.5.4 Interrupts

The interrupt request lines are connected to the interrupt controller. Using the OSC32KCTRL interrupts requires the interrupt controller to be configured first.

#### Related Links

[10.2 Nested Vector Interrupt Controller](#)

### 29.5.5 Events

The events of this peripheral are connected to the Event System.

#### Related Links

[31. EVSYS – Event System](#)

### 29.5.6 Debug Operation

When the CPU is halted in debug mode, OSC32KCTRL will continue normal operation. If OSC32KCTRL is configured in a way that requires it to be periodically serviced by the CPU through interrupts or similar, improper operation or data loss may result during debugging.

### 29.5.7 Register Access Protection

All registers with write access can be write-protected optionally by the Peripheral Access Controller (PAC), except for the following registers:

- Interrupt Flag Status and Clear (INTFLAG) register

Optional write protection by the Peripheral Access Controller (PAC) is denoted by the "PAC Write Protection" property in each individual register description.

PAC write protection does not apply to accesses through an external debugger.

#### Related Links

[27. PAC - Peripheral Access Controller](#)

### 29.5.8 Analog Connections

The external 32.768kHz crystal must be connected between the XIN32 and XOUT32 pins, along with any required load capacitors. For details on recommended oscillator characteristics and capacitor load, refer to the related links.

## 29.6 Functional Description

### 29.6.1 Principle of Operation

XOSC32K and OSCULP32K are configured via OSC32KCTRL control registers. Through this interface, the sub-peripherals are enabled, disabled, or have their calibration values updated.

The STATUS register gathers different status signals coming from the sub-peripherals of OSC32KCTRL. The status signals can be used to generate system interrupts, and in some cases wake up the system from standby mode, provided the corresponding interrupt is enabled.

### 29.6.2 32 kHz External Crystal Oscillator (XOSC32K) Operation

The XOSC32K can operate in two different modes:

- External clock, with an external clock signal connected to XIN32
- Crystal oscillator, with an external 32.768 kHz crystal connected between XIN32 and XOUT32

At reset, the XOSC32K is disabled, and the XIN32/XOUT32 pins can either be used as General Purpose I/O (GPIO) pins or by other peripherals in the system.

When XOSC32K is enabled, the operating mode determines the GPIO usage. When in crystal oscillator mode, the XIN32 and XOUT32 pins are controlled by the OSC32KCTRL, and GPIO functions are overridden on both pins. When in external clock mode, only the XIN32 pin will be overridden and controlled by the OSC32KCTRL, while the XOUT32 pin can still be used as a GPIO pin.

<b>Enabling, Disabling</b>	The XOSC32K is enabled by writing a '1' to the Enable bit in the 32 kHz External Crystal Oscillator Control register (XOSC32K.ENABLE = 1). The XOSC32K is disabled by writing a '0' to the Enable bit in the 32 kHz External Crystal Oscillator Control register (XOSC32K.ENABLE = 0).
<b>Mode Selection</b>	To enable the XOSC32K in Crystal Oscillator mode, the XTALEN bit in the 32 kHz External Crystal Oscillator Control register must be written (XOSC32K.XTALEN = 1). If XOSC32K.XTALEN is '0', the External Clock Input mode will be enabled.
<b>Gain Selection</b>	When a crystal oscillator is selected, a controllable gain is provided. Writing to the Control Gain Mode bit field (XOSC32K.CGM) will select a gain setting appropriate for the desired trade-off between low power and high speed.
<b>32KHz and 1KHz Output</b>	The XOSC32K 32.768 kHz output is enabled by setting the 32 kHz Output Enable bit in the 32 kHz External Crystal Oscillator Control register (XOSC32K.EN32K=1). The XOSC32K also has a 1.024 kHz clock output. This is enabled by setting the 1 kHz Output Enable bit in the 32 kHz External Crystal Oscillator Control register (XOSC32K.EN1K = 1).
<b>Configuration Lock</b>	It is also possible to lock the XOSC32K configuration by setting the Write Lock bit in the 32 kHz External Crystal Oscillator Control register (XOSC32K.WRTLOCK=1). If set, the XOSC32K configuration is locked until a Power-On Reset (POR) is detected.

The XOSC32K will behave differently in different sleep modes based on the settings of XOSC32K.RUNSTDBY, XOSC32K.ONDEMAND, and XOSC32K.ENABLE. If XOSC32KCTRL.ENABLE = 0, the XOSC32K will be always stopped. For XOSC32KCTRL.ENABLE = 1, this table is valid:

# SAM D5x/E5x Family Data Sheet

## OSC32CTRL – 32KHz Oscillators Controller

**Table 29-1. XOSC32K Sleep Behavior**

CPU Mode	XOSC32K. RUNSTDBY	XOSC32K. ONDEMAND	Sleep Behavior of XOSC32K and CFD
Active or Idle	-	0	Always run
Active or Idle	-	1	Run if requested by peripheral
Standby	1	0	Always run
Standby	1	1	Run if requested by peripheral
Standby	0	-	Run if requested by peripheral

As a crystal oscillator usually requires a very long start-up time, the 32KHz External Crystal Oscillator will keep running across resets when XOSC32K.ONDEMAND=0, except for power-on reset (POR). After a reset or when waking up from a sleep mode where the XOSC32K was disabled, the XOSC32K will need a certain amount of time to stabilize on the correct frequency. This start-up time can be configured by changing the Oscillator Start-Up Time bit group (XOSC32K.STARTUP) in the 32 kHz External Crystal Oscillator Control register. During the start-up time, the oscillator output is masked to ensure that no unstable clock propagates to the digital logic.

Once the external clock or crystal oscillator is stable and ready to be used as a clock source, the XOSC32K Ready bit in the Status register is set (STATUS.XOSC32KRDY=1). The transition of STATUS.XOSC32KRDY from '0' to '1' generates an interrupt if the XOSC32K Ready bit in the Interrupt Enable Set register is set (INTENSET.XOSC32KRDY=1).

The XOSC32K can be used as a source for Generic Clock Generators (GCLK) or for the Real-Time Counter (RTC). Before enabling the GCLK or the RTC module, the corresponding oscillator output must be enabled (XOSC32K.EN32K or XOSC32K.EN1K) in order to ensure proper operation. In the same way, the GCLK or RTC modules must be disabled before the clock selection is changed. For details on RTC clock configuration, refer also to [29.6.6 Real-Time Counter Clock Selection](#).

### Related Links

[14. GCLK - Generic Clock Controller](#)

[21. RTC – Real-Time Counter](#)

### 29.6.3 Clock Failure Detection Operation

The Clock Failure Detector (CFD) allows the user to monitor the external clock or crystal oscillator signal provided by the external oscillator (XOSC32K). The CFD detects failing operation of the XOSC32K clock with reduced latency, and allows to switch to a safe clock source in case of clock failure. The user can also switch from the safe clock back to XOSC32K in case of recovery. The safe clock is derived from the OSCULP32K oscillator with a configurable prescaler. This allows to configure the safe clock in order to fulfill the operative conditions of the microcontroller.

In sleep modes, CFD operation is automatically disabled when the external oscillator is not requested to run by a peripheral. See the Sleep Behavior table above when this is the case.

The user interface registers allow to enable, disable, and configure the CFD. The Status register provides status flags on failure and clock switch conditions. The CFD can optionally trigger an interrupt or an event when a failure is detected.

# SAM D5x/E5x Family Data Sheet

## OSC32CTRL – 32KHz Oscillators Controller

### Clock Failure Detection

The CFD is reset only at power-on (POR). The CFD does not monitor the XOSC32K clock when the oscillator is disabled (XOSC32K.ENABLE=0).

Before starting CFD operation, the user must start and enable the safe clock source (OSCULP32K oscillator).

CFD operation is started by writing a '1' to the CFD Enable bit in the External Oscillator Control register (CFDCTRL.CFDEN). After starting or restarting the XOSC32K, the CFD does not detect failure until the start-up time has elapsed. The start-up time is configured by the Oscillator Start-Up Time in the External Multipurpose Crystal Oscillator Control register (XOSC32K.STARTUP). Once the XOSC32K Start-Up Time is elapsed, the XOSC32K clock is constantly monitored.

During a period of 4 safe clocks (monitor period), the CFD watches for a clock activity from the XOSC32K. There must be at least one rising and one falling XOSC32K clock edge during 4 safe clock periods to meet non-failure conditions. If no or insufficient activity is detected, the failure status is asserted: The Clock Failure Detector status bit in the Status register (STATUS.XOSC32KFAIL) and the Clock Failure Detector interrupt flag bit in the Interrupt Flag register (INTFLAG.XOSC32KFAIL) are set. If the XOSC32KFAIL bit in the Interrupt Enable Set register (INTENSET.XOSC32KFAIL) is set, an interrupt is generated as well. If the Event Output enable bit in the Event Control register (EVCTRL.CFDEO) is set, an output event is generated, too.

After a clock failure was issued the monitoring of the XOSC32K clock is continued, and the Clock Failure Detector status bit in the Status register (STATUS.XOSC32KFAIL) reflects the current XOSC32K activity.

### Clock Switch

When a clock failure is detected, the XOSC32K clock is replaced by the safe clock in order to maintain an active clock during the XOSC32K clock failure. The safe clock source is the OSCULP32K oscillator clock. Both 32KHz and 1KHz outputs of the XOSC32K are replaced by the respective OSCULP32K 32KHz and 1KHz outputs. The safe clock source can be scaled down by a configurable prescaler to ensure that the safe clock frequency does not exceed the operating conditions selected by the application. When the XOSC32K clock is switched to the safe clock, the Clock Switch bit in the Status register (STATUS.XOSC32KSW) is set.

When the CFD has switched to the safe clock, the XOSC32K is not disabled. If desired, the application must take the necessary actions to disable the oscillator. The application must also take the necessary actions to configure the system clocks to continue normal operations. In the case the application can recover the XOSC32K, the application can switch back to the XOSC32K clock by writing a '1' to Switch Back Enable bit in the Clock Failure Control register (CFDCTRL.SWBACK). Once the XOSC32K clock is switched back, the Switch Back bit (CFDCTRL.SWBACK) is cleared by hardware.

### Prescaler

The CFD has an internal configurable prescaler to generate the safe clock from the OSCULP32K oscillator. The prescaler size allows to scale down the OSCULP32K oscillator so the safe clock frequency is not higher than the XOSC32K clock frequency monitored by the CFD. The maximum division factor is 2.

The prescaler is applied on both outputs (32KHz and 1KHz) of the safe clock.

#### Example 29-1. Example

For an external crystal oscillator at 32KHz and the OSCULP32K frequency is 32KHz, the XOSC32K.CFDPRESC should be set to 0 for a safe clock of equal frequency.



### Event

If the Event Output Enable bit in the Event Control register (EVCTRL.CFDEO) is set, the CFD clock failure will be output on the Event Output. When the CFD is switched to the safe clock, the CFD clock failure will not be output on the Event Output.

### Sleep Mode

The CFD is halted depending on configuration of the XOSC32K and the peripheral clock request. For further details, refer to the Sleep Behavior table above. The CFD interrupt can be used to wake up the device from sleep modes.

#### 29.6.4 32 kHz Ultra Low-Power Internal Oscillator (OSCULP32K) Operation

The OSCULP32K provides a tunable, low-speed, and ultra low-power clock source. The OSCULP32K is factory-calibrated under typical voltage and temperature conditions.

The OSCULP32K is enabled by default after a Power-on Reset (POR), and will always run except during POR. The frequency of the OSCULP32K Oscillator is controlled by the value in the Calibration bits in the 32 kHz Ultra Low-Power Internal Oscillator Control register (OSCULP32K.CALIB). This data is used to compensate for process variations.

OSCULP32K.CALIB is automatically loaded from Flash Factory Calibration during start-up. The calibration value can be overridden by the user by writing to OSCULP32K.CALIB.

Users can lock the OSCULP32K configuration by setting the Write Lock bit in the 32 kHz Ultra Low-Power Internal Oscillator Control register (OSCULP32K.WRTLOCK = 1). If set, the OSCULP32K configuration is locked until POR is detected.

The OSCULP32K can be used as a source for Generic Clock Generators (GCLK) or for the Real-Time Counter (RTC). To ensure proper operation, the GCLK or RTC modules must be disabled before the clock selection is changed.

### Related Links

- [21. RTC – Real-Time Counter](#)
- [29.6.6 Real-Time Counter Clock Selection](#)
- [14. GCLK - Generic Clock Controller](#)

#### 29.6.5 Watchdog Timer Clock Selection

The Watchdog Timer (WDT) uses the internal 1.024kHz OSCULP32K output clock. This clock is running all the time and internally enabled when requested by the WDT module.

### Related Links

- [20. WDT – Watchdog Timer](#)

#### 29.6.6 Real-Time Counter Clock Selection

Before enabling the RTC module, the RTC clock must be selected first. All oscillator outputs are valid as RTC clock. The selection is done in the RTC Control register (RTCCTRL). To ensure a proper operation, it is highly recommended to disable the RTC module first, before the RTC clock source selection is changed.

### Related Links

- [21. RTC – Real-Time Counter](#)

#### 29.6.7 Interrupts

The OSC32KCTRL has the following interrupt sources:

# SAM D5x/E5x Family Data Sheet

## OSC32KCTRL – 32KHz Oscillators Controller

---

- XOSC32KRDY - 32KHz Crystal Oscillator Ready: A 0-to-1 transition on the STATUS.XOSC32KRDY bit is detected
- XOSC32KFAIL - Clock Failure Detector: A 0-to-1 transition on the STATUS.XOSC32KFAIL bit is detected

All these interrupts are synchronous wake-up source.

Each interrupt source has an interrupt flag associated with it. The interrupt flag in the Interrupt Flag Status and Clear register (INTFLAG) is set when the interrupt condition occurs. Each interrupt can be enabled individually by setting the corresponding bit in the Interrupt Enable Set register (INTENSET), and disabled by setting the corresponding bit in the Interrupt Enable Clear register (INTENCLR). An interrupt request is generated when the interrupt flag is set and the corresponding interrupt is enabled. The interrupt request remains active until the interrupt flag is cleared, the interrupt is disabled or the OSC32KCTRL is reset. See the INTFLAG register for details on how to clear interrupt flags.

The OSC32KCTRL has one common interrupt request line for all the interrupt sources. The user must read the INTFLAG register to determine which interrupt condition is present. Refer to the INTFLAG register for details.

**Note:** Interrupts must be globally enabled for interrupt requests to be generated.

### Related Links

[18. PM – Power Manager](#)

[10.2 Nested Vector Interrupt Controller](#)

### 29.6.8 Events

The CFD can generate the following output event:

- Clock Failure Detector (XOSC32KFAIL): Generated when the Clock Failure Detector status bit is set in the Status register (STATUS.XOSC32KFAIL). The CFD event is not generated when the Clock Switch bit (STATUS.SWBACK) in the Status register is set.

Writing a '1' to an Event Output bit in the Event Control register (EVCTRL.CFDEO) enables the CFD output event. Writing a '0' to this bit disables the CFD output event. Refer to the Event System chapter for details on configuring the event system.

# SAM D5x/E5x Family Data Sheet

## OSC32KCTRL – 32KHz Oscillators Controller

### 29.7 Register Summary

Offset	Name	Bit Pos.							
0x00	INTENCLR	7:0					XOSC32KFAI L		XOSC32KRD Y
		15:8							
		23:16							
		31:24							
0x04	INTENSET	7:0					XOSC32KFAI L		XOSC32KRD Y
		15:8							
		23:16							
		31:24							
0x08	INTFLAG	7:0					XOSC32KFAI L		XOSC32KRD Y
		15:8							
		23:16							
		31:24							
0x0C	STATUS	7:0				XOSC32KSW	XOSC32KFAI L		XOSC32KRD Y
		15:8							
		23:16							
		31:24							
0x10	RTCCTRL	7:0						RTCSEL[2:0]	
0x11 ... 0x13	Reserved								
0x14	XOSC32K	7:0	ONDEMAND	RUNSTDBY		EN1K	EN32K	XTALEN	ENABLE
		15:8			CGM[1:0]	WRTLOCK			STARTUP[2:0]
0x16	CFDCTRL	7:0					CFDPRESC	SWBACK	CFDEN
0x17	EVCTRL	7:0							CFDEO
0x18 ... 0x1B	Reserved								
0x1C	OSCULP32K	7:0					EN1K	EN32K	
		15:8	WRTLOCK						CALIB[5:0]
		23:16							
		31:24							

### 29.8 Register Description

Registers can be 8, 16, or 32 bits wide. Atomic 8-, 16-, and 32-bit accesses are supported. In addition, the 8-bit quarters and 16-bit halves of a 32-bit register and the 8-bit halves of a 16-bit register can be accessed directly.

All registers with write-access can be write-protected optionally by the peripheral access controller (PAC). Optional Write-Protection by the Peripheral Access Controller (PAC) is denoted by the "PAC Write-

# SAM D5x/E5x Family Data Sheet

## OSC32KCTRL – 32KHz Oscillators Controller

---

Protection" property in the register description. Write-protection does not apply to accesses through an external debugger.

### Related Links

[27. PAC - Peripheral Access Controller](#)

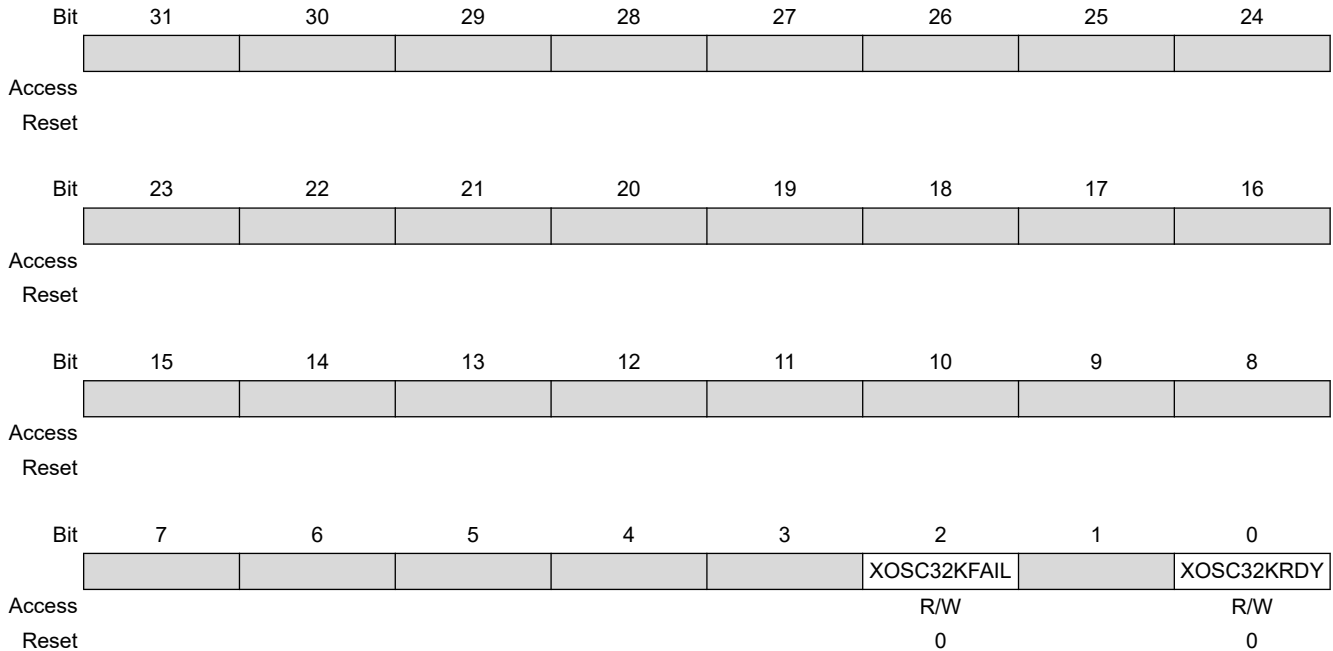
# SAM D5x/E5x Family Data Sheet

## OSC32KCTRL – 32KHz Oscillators Controller

### 29.8.1 Interrupt Enable Clear

**Name:** INTENCLR  
**Offset:** 0x00  
**Reset:** 0x00000000  
**Property:** PAC Write-Protection

This register allows the user to disable an interrupt without doing a read-modify-write operation. Changes in this register will also be reflected in the Interrupt Enable Set register (INTENSET).



#### Bit 2 – XOSC32KFAIL XOSC32K Clock Failure Detector Interrupt Enable

Writing a '0' to this bit has no effect.

Writing a '1' to this bit will clear the XOSC32K Clock Failure Interrupt Enable bit, which disables the XOSC32K Clock Failure interrupt.

Value	Description
0	The XOSC32K Clock Failure Detection is disabled.
1	The XOSC32K Clock Failure Detection is enabled. An interrupt request will be generated when the XOSC32K Clock Failure Detection interrupt flag is set.

#### Bit 0 – XOSC32KRDY XOSC32K Ready Interrupt Enable

Writing a '0' to this bit has no effect.

Writing a '1' to this bit will clear the XOSC32K Ready Interrupt Enable bit, which disables the XOSC32K Ready interrupt.

Value	Description
0	The XOSC32K Ready interrupt is disabled.
1	The XOSC32K Ready interrupt is enabled.

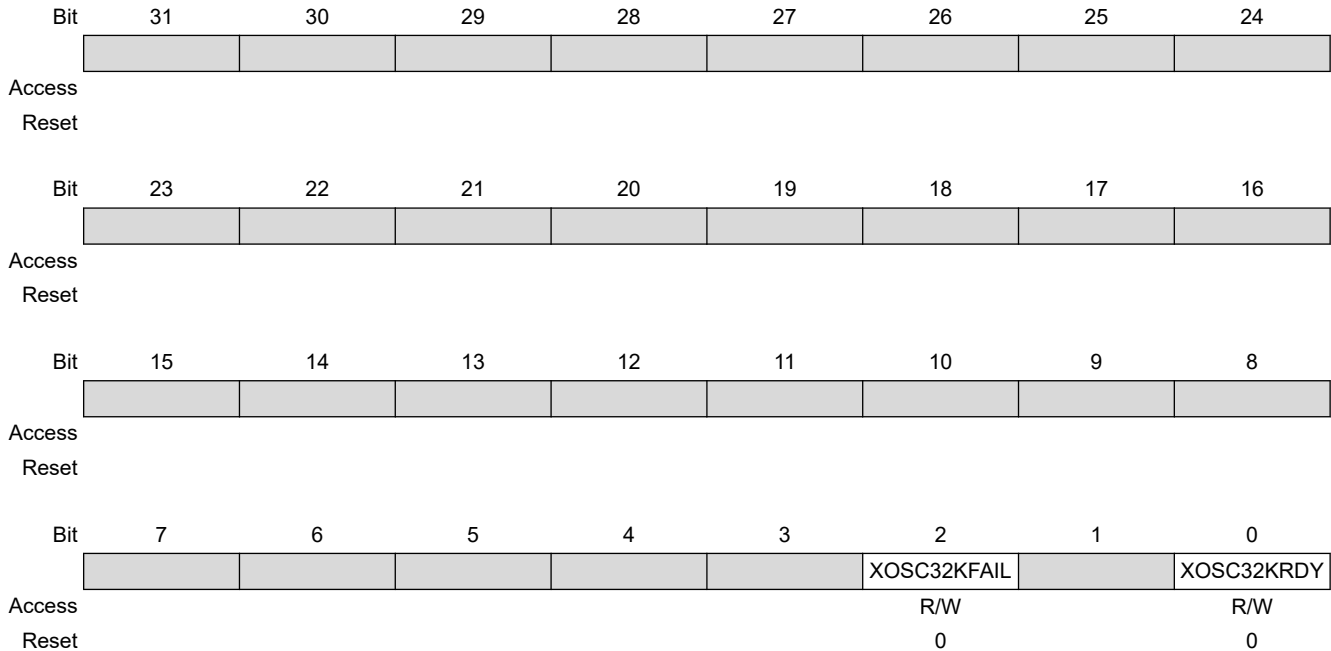
# SAM D5x/E5x Family Data Sheet

## OSC32KCTRL – 32KHz Oscillators Controller

### 29.8.2 Interrupt Enable Set

**Name:** INTENSET  
**Offset:** 0x04  
**Reset:** 0x00000000  
**Property:** PAC Write-Protection

This register allows the user to disable an interrupt without doing a read-modify-write operation. Changes in this register will also be reflected in the Interrupt Enable Clear register (INTENCLR).



#### Bit 2 – XOSC32KFAIL XOSC32K Clock Failure Detector Interrupt Enable

Writing a '0' to this bit has no effect.

Writing a '1' to this bit will set the XOSC32K Clock Failure Interrupt Enable bit, which enables the XOSC32K Clock Failure interrupt.

Value	Description
0	The XOSC32K Clock Failure Detection is disabled.
1	The XOSC32K Clock Failure Detection is enabled. An interrupt request will be generated when the XOSC32K Clock Failure Detection interrupt flag is set.

#### Bit 0 – XOSC32KRDY XOSC32K Ready Interrupt Enable

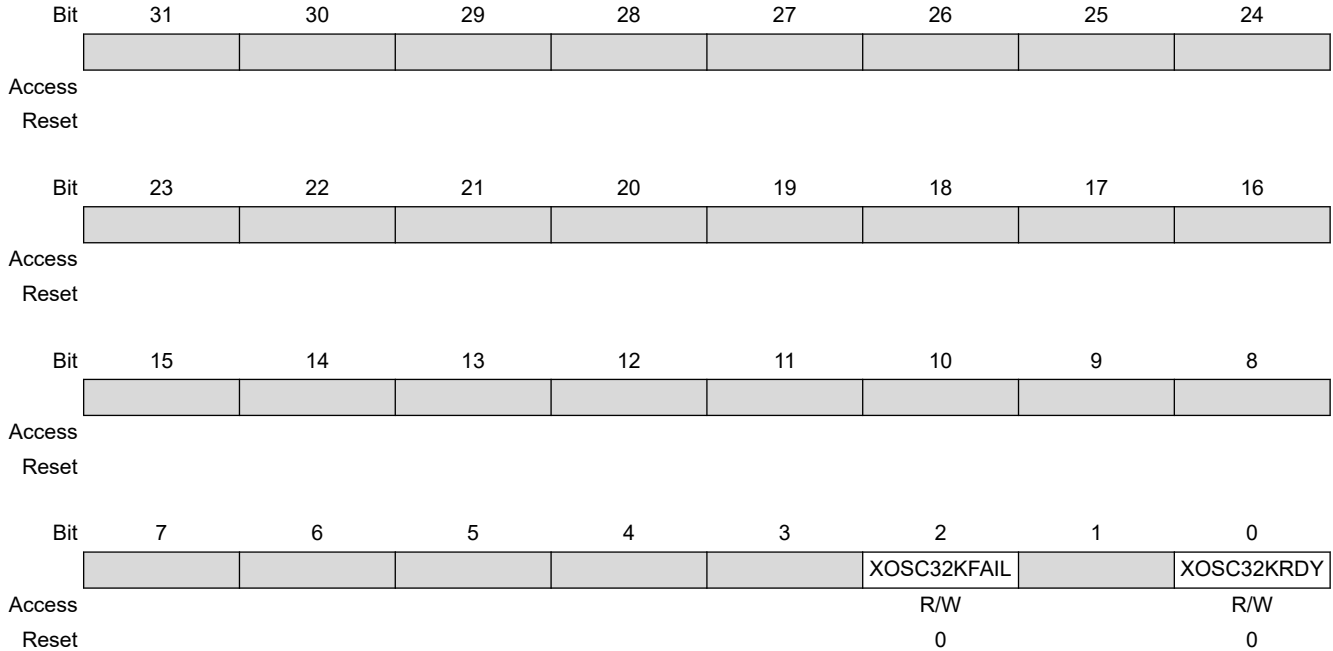
Writing a '0' to this bit has no effect.

Writing a '1' to this bit will set the XOSC32K Ready Interrupt Enable bit, which enables the XOSC32K Ready interrupt.

Value	Description
0	The XOSC32K Ready interrupt is disabled.
1	The XOSC32K Ready interrupt is enabled.

### 29.8.3 Interrupt Flag Status and Clear

**Name:** INTFLAG  
**Offset:** 0x08  
**Reset:** 0x00000000  
**Property:** –



**Bit 2 – XOSC32KFAIL** XOSC32K Clock Failure Detector

This flag is cleared by writing a '1' to it.

This flag is set on a zero-to-one transition of the XOSC32K Clock Failure Detection bit in the Status register (STATUS.XOSC32KFAIL) and will generate an interrupt request if INTENSET.XOSC32KFAIL is '1'.

Writing a '0' to this bit has no effect.

Writing a '1' to this bit will clear the XOSC32K Clock Failure Detection flag.

**Bit 0 – XOSC32KRDY** XOSC32K Ready

This flag is cleared by writing a '1' to it.

This flag is set by a zero-to-one transition of the XOSC32K Ready bit in the Status register (STATUS.XOSC32KRDY), and will generate an interrupt request if INTENSET.XOSC32KRDY=1.

Writing a '0' to this bit has no effect.

Writing a '1' to this bit clears the XOSC32K Ready interrupt flag.

# SAM D5x/E5x Family Data Sheet

## OSC32CTRL – 32KHz Oscillators Controller

### 29.8.4 Status

**Name:** STATUS  
**Offset:** 0x0C  
**Reset:** 0x00000000  
**Property:** –

	Bit	31	30	29	28	27	26	25	24										
		<table border="1" style="width: 100%; height: 15px; border-collapse: collapse;"> <tr> <td style="width: 12.5%;"></td> <td style="width: 12.5%;"></td> <td style="width: 12.5%;"></td> <td style="width: 12.5%;"></td> <td style="width: 12.5%;"></td> <td style="width: 12.5%;"></td> <td style="width: 12.5%;"></td> <td style="width: 12.5%;"></td> <td style="width: 12.5%;"></td> <td style="width: 12.5%;"></td> </tr> </table>																	
Access																			
Reset																			
	Bit	23	22	21	20	19	18	17	16										
		<table border="1" style="width: 100%; height: 15px; border-collapse: collapse;"> <tr> <td style="width: 12.5%;"></td> <td style="width: 12.5%;"></td> <td style="width: 12.5%;"></td> <td style="width: 12.5%;"></td> <td style="width: 12.5%;"></td> <td style="width: 12.5%;"></td> <td style="width: 12.5%;"></td> <td style="width: 12.5%;"></td> <td style="width: 12.5%;"></td> <td style="width: 12.5%;"></td> </tr> </table>																	
Access																			
Reset																			
	Bit	15	14	13	12	11	10	9	8										
		<table border="1" style="width: 100%; height: 15px; border-collapse: collapse;"> <tr> <td style="width: 12.5%;"></td> <td style="width: 12.5%;"></td> <td style="width: 12.5%;"></td> <td style="width: 12.5%;"></td> <td style="width: 12.5%;"></td> <td style="width: 12.5%;"></td> <td style="width: 12.5%;"></td> <td style="width: 12.5%;"></td> <td style="width: 12.5%;"></td> <td style="width: 12.5%;"></td> </tr> </table>																	
Access																			
Reset																			
	Bit	7	6	5	4	3	2	1	0										
		<table border="1" style="width: 100%; height: 15px; border-collapse: collapse;"> <tr> <td style="width: 12.5%;"></td> <td style="width: 12.5%;"></td> <td style="width: 12.5%;"></td> <td style="width: 12.5%;"></td> <td style="width: 12.5%;"></td> </tr> </table>									XOSC32KSW	XOSC32KFAIL	<table border="1" style="width: 100%; height: 15px; border-collapse: collapse;"> <tr> <td style="width: 12.5%;"></td> <td style="width: 12.5%;"></td> </tr> </table>				XOSC32KRDY		
Access						R	R			R									
Reset						0	0			0									

#### Bit 3 – XOSC32KSW XOSC32K Clock Switch

Value	Description
0	XOSC32K is not switched and provided the crystal oscillator.
1	XOSC32K is switched to be provided by the safe clock.

#### Bit 2 – XOSC32KFAIL XOSC32K Clock Failure Detector

Value	Description
0	XOSC32K is passing failure detection.
1	XOSC32K is not passing failure detection.

#### Bit 0 – XOSC32KRDY XOSC32K Ready

Value	Description
0	XOSC32K is not ready.
1	XOSC32K is stable and ready to be used as a clock source.



# SAM D5x/E5x Family Data Sheet

## OSC32KCTRL – 32KHz Oscillators Controller

### 29.8.5 RTC Clock Selection Control

**Name:** RTCCTRL  
**Offset:** 0x10  
**Reset:** 0x00  
**Property:** PAC Write-Protection

	7	6	5	4	3	2	1	0	
							RTCSEL[2:0]		
Access							R/W	R/W	R/W
Reset							0	0	0

#### Bits 2:0 – RTCSEL[2:0] RTC Clock Selection

These bits select the source for the RTC.

Value	Name	Description
0x0	ULP1K	1.024kHz from 32KHz internal ULP oscillator
0x1	ULP32K	32.768kHz from 32KHz internal ULP oscillator
0x2, 0x3	Reserved	-
0x4	XOSC1K	1.024kHz from 32KHz external oscillator
0x5	XOSC32K	32.768kHz from 32KHz external crystal oscillator
0x6	Reserved	
0x7	Reserved	

# SAM D5x/E5x Family Data Sheet

## OSC32CTRL – 32KHz Oscillators Controller

### 29.8.6 32KHz External Crystal Oscillator (XOSC32K) Control

**Name:** XOSC32K  
**Offset:** 0x14  
**Reset:** 0x2080  
**Property:** PAC Write-Protection

	Bit	15	14	13	12	11	10	9	8
		CGM[1:0]		WRTLOCK		STARTUP[2:0]			
Access		R/W	R/W	R/W		R/W	R/W	R/W	
Reset		0	1	0		0	0	0	
	Bit	7	6	5	4	3	2	1	0
		ONDEMAND	RUNSTDBY		EN1K	EN32K	XTALEN	ENABLE	
Access		R/W	R/W		R/W	R/W	R/W	R/W	
Reset		1	0		0	0	0	0	

#### Bits 14:13 – CGM[1:0] Control Gain Mode

These bits control the gain of the external crystal oscillator.

Value	Name	Description
0x1	XT	Standard mode
0x2	HS	High Speed mode

#### Bit 12 – WRTLOCK Write Lock

This bit locks the XOSC32K register for future writes, effectively freezing the XOSC32K configuration.

Value	Description
0	The XOSC32K configuration is not locked.
1	The XOSC32K configuration is locked.

#### Bits 10:8 – STARTUP[2:0] Oscillator Start-Up Time

These bits select the start-up time for the oscillator.

The OSCULP32K oscillator is used to clock the start-up counter.

**Table 29-2. Start-Up Time for 32KHz External Crystal Oscillator**

STARTUP[2:0]	Number of OSCULP32K Clock Cycles	Number of XOSC32K Clock Cycles	Approximate Equivalent Time [ms]
0x0	2048	3	62.592
0x1	4096	3	125.092
0x2	16384	3	500.092
0x3	32768	3	1000.092
0x4	65536	3	2000.092
0x5	131072	3	4000.092
0x6	262144	3	8000.092
0x7	-	-	Reserved

# SAM D5x/E5x Family Data Sheet

## OSC32CTRL – 32KHz Oscillators Controller

### Note:

1. Actual Start-Up time is 1 OSCULP32K cycle + 3 XOSC32K cycles.
2. The given time assumes an XTAL frequency of 32.768kHz.

### Bit 7 – ONDEMAND On Demand Control

This bit controls how the XOSC32K behaves when a peripheral clock request is detected. For details, refer to [Table 29-1](#).

### Bit 6 – RUNSTDBY Run in Standby

This bit controls how the XOSC32K behaves during standby sleep mode. For details, refer to [Table 29-1](#).

### Bit 4 – EN1K 1KHz Output Enable

Value	Description
0	The 1KHz output is disabled.
1	The 1KHz output is enabled.

### Bit 3 – EN32K 32KHz Output Enable

Value	Description
0	The 32KHz output is disabled.
1	The 32KHz output is enabled.

### Bit 2 – XTALEN Crystal Oscillator Enable

This bit controls the connections between the I/O pads and the external clock or crystal oscillator.

Value	Description
0	External clock connected on XIN32. XOUT32 can be used as general-purpose I/O.
1	Crystal connected to XIN32/XOUT32.

### Bit 1 – ENABLE Oscillator Enable

Value	Description
0	The oscillator is disabled.
1	The oscillator is enabled.

# SAM D5x/E5x Family Data Sheet

## OSC32KCTRL – 32KHz Oscillators Controller

### 29.8.7 Clock Failure Detector Control

**Name:** CFDCTRL  
**Offset:** 0x16  
**Reset:** 0x00  
**Property:** PAC Write-Protection

	7	6	5	4	3	2	1	0
						CFDPRESC	SWBACK	CFDEN
Access						R/W	R/W	R/W
Reset						0	0	0

**Bit 2 – CFDPRESC** Clock Failure Detector Prescaler  
 This bit selects the prescaler for the Clock Failure Detector.

Value	Description
0	The CFD safe clock frequency is the OSCULP32K frequency
1	The CFD safe clock frequency is the OSCULP32K frequency divided by 2

**Bit 1 – SWBACK** Clock Switch Back  
 This bit controls the XOSC32K output switch back to the external clock or crystal scillator in case of clock recovery.

Value	Description
0	The clock switch is disabled.
1	The clock switch is enabled. This bit is reset when the XOSC32K output is switched back to the external clock or crystal oscillator.

**Bit 0 – CFDEN** Clock Failure Detector Enable  
 This bit selects the Clock Failure Detector state.

Value	Description
0	The CFD is disabled.
1	The CFD is enabled.

# SAM D5x/E5x Family Data Sheet

## OSC32KCTRL – 32KHz Oscillators Controller

### 29.8.8 Event Control

**Name:** EVCTRL  
**Offset:** 0x17  
**Reset:** 0x00  
**Property:** PAC Write-Protection

Bit	7	6	5	4	3	2	1	0
								CFDEO
Access								R/W
Reset								0

#### Bit 0 – CFDEO Clock Failure Detector Event Out Enable

This bit controls whether the Clock Failure Detector event output is enabled and an event will be generated when the CFD detects a clock failure.

Value	Description
0	Clock Failure Detector Event output is disabled, no event will be generated.
1	Clock Failure Detector Event output is enabled, an event will be generated.

# SAM D5x/E5x Family Data Sheet

## OSC32KCTRL – 32KHz Oscillators Controller

### 29.8.9 32KHz Ultra Low Power Internal Oscillator (OSCULP32K) Control

**Name:** OSCULP32K  
**Offset:** 0x1C  
**Reset:** 0x00000000  
**Property:** PAC Write-Protection

Bit	31	30	29	28	27	26	25	24	
Access									
Reset									
Bit	23	22	21	20	19	18	17	16	
Access									
Reset									
Bit	15	14	13	12	11	10	9	8	
	WRTLOCK		CALIB[5:0]						
Access	R/W		R/W	R/W	R/W	R/W	R/W	R/W	
Reset	0		0	0	0	0	0	x	
Bit	7	6	5	4	3	2	1	0	
						EN1K	EN32K		
Access						R/W	R/W		
Reset						1	1		

#### Bit 15 – WRTLOCK Write Lock

This bit locks the OSCULP32K register for future writes to fix the OSCULP32K configuration.

Value	Description
0	The OSCULP32K configuration is not locked.
1	The OSCULP32K configuration is locked.

#### Bits 13:8 – CALIB[5:0] Oscillator Calibration

These bits control the oscillator calibration.

These bits are loaded from Flash Calibration at startup.

#### Bit 2 – EN1K 1kHz Output Enable

Value	Description
0	The 1kHz output is disabled
1	The 1kHz output is enabled.

#### Bit 1 – EN32K

Value	Description
0	The 32kHz output is disabled.
1	The 32kHz output is enabled.

## 30. FREQM – Frequency Meter

### 30.1 Overview

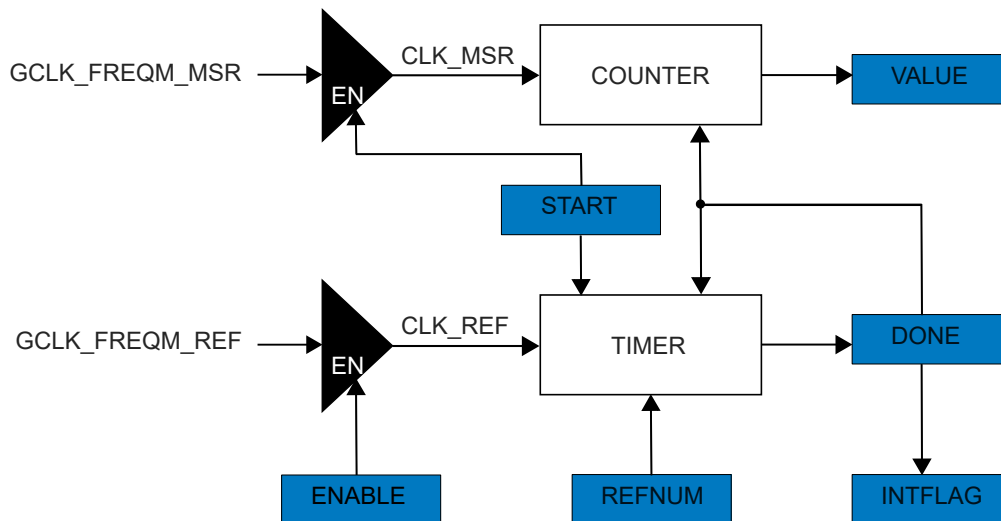
The Frequency Meter (FREQM) can be used to accurately measure the frequency of a clock by comparing it to a known reference clock.

### 30.2 Features

- Ratio can be measured with 24-bit accuracy
- Accurately measures the frequency of an input clock with respect to a reference clock
- Reference clock can be selected from the available GCLK\_FREQM\_REF sources
- Measured clock can be selected from the available GCLK\_FREQM\_MSR sources

### 30.3 Block Diagram

Figure 30-1. FREQM Block Diagram



### 30.4 Signal Description

Not applicable.

### 30.5 Product Dependencies

In order to use this peripheral, other parts of the system must be configured correctly, as described below.

### 30.5.1 I/O Lines

The GCLK I/O lines (GCLK\_IO[7:0]) can be used as measurement or reference clock sources. This requires the I/O pins to be configured.

### 30.5.2 Power Management

The FREQM will continue to operate in idle sleep mode where the selected source clock is running. The FREQM's interrupts can be used to wake up the device from idle sleep mode. Refer to the Power Manager chapter for details on the different sleep modes.

#### Related Links

[18. PM – Power Manager](#)

### 30.5.3 Clocks

The clock for the FREQM bus interface (CLK\_APB\_FREQM) is enabled and disabled by the Main Clock Controller, the default state of CLK\_APB\_FREQM can be found in [Peripheral Clock Masking](#).

Two generic clocks are used by the FREQM: Reference Clock (GCLK\_FREQM\_REF) and Measurement Clock (GCLK\_FREQM\_MSR).

GCLK\_FREQM\_REF is required to clock the internal reference timer, which acts as the frequency reference.

GCLK\_FREQM\_MSR is required to clock a ripple counter for frequency measurement. These clocks must be configured and enabled in the generic clock controller before using the FREQM.

#### Related Links

[15. MCLK – Main Clock](#)

[15.6.2.6 Peripheral Clock Masking](#)

[14. GCLK - Generic Clock Controller](#)

### 30.5.4 DMA

Not applicable.

### 30.5.5 Interrupts

The interrupt request line is connected to the interrupt controller. Using FREQM interrupt requires the interrupt controller to be configured first.

#### Related Links

[10.2.2 Interrupt Line Mapping](#)

### 30.5.6 Events

Not applicable

### 30.5.7 Debug Operation

When the CPU is halted in debug mode the FREQM continues its normal operation. The FREQM cannot be halted when the CPU is halted in debug mode. If the FREQM is configured in a way that requires it to be periodically serviced by the CPU, improper operation or data loss may result during debugging.

### 30.5.8 Register Access Protection

All registers with write access can be write-protected optionally by the Peripheral Access Controller (PAC), except the following registers:



- Control B register (CTRLB)
- Interrupt Flag Status and Clear register (INTFLAG)
- Status register (STATUS)

Optional write protection by the Peripheral Access Controller (PAC) is denoted by the "PAC Write Protection" property in each individual register description.

Write-protection does not apply to accesses through an external debugger.

### Related Links

[27. PAC - Peripheral Access Controller](#)

## 30.6 Functional Description

### 30.6.1 Principle of Operation

FREQM counts the number of periods of the measured clock (GCLK\_FREQM\_MSR) with respect to the reference clock (GCLK\_FREQM\_REF). The measurement is done for a period of  $\text{REFNUM}/f_{\text{CLK\_REF}}$  and stored in the Value register (VALUE.VALUE). REFNUM is the number of Reference clock cycles selected in the Configuration A register (CFG.A.REFNUM).

The frequency of the measured clock,  $f_{\text{CLK\_MSR}}$ , is calculated by

$$f_{\text{CLK\_MSR}} = \left( \frac{\text{VALUE}}{\text{REFNUM}} \right) f_{\text{CLK\_REF}}$$

### 30.6.2 Basic Operation

#### 30.6.2.1 Initialization

Before enabling FREQM, the device and peripheral must be configured:

- Each of the generic clocks (GCLK\_FREQM\_REF and GCLK\_FREQM\_MSR) must be configured and enabled.

•



**Important:** The reference clock must be slower than the measurement clock.

- Write the number of Reference clock cycles for which the measurement is to be done in the Configuration A register (CFG.A.REFNUM). This must be a non-zero number.

The following register is enable-protected, meaning that it can only be written when the FREQM is disabled (CTRLA.ENABLE=0):

- Configuration A register (CFG.A)

Enable-protection is denoted by the "Enable-Protected" property in the register description.

### Related Links

[14. GCLK - Generic Clock Controller](#)

#### 30.6.2.2 Enabling, Disabling and Resetting

The FREQM is enabled by writing a '1' to the Enable bit in the Control A register (CTRLA.ENABLE). The peripheral is disabled by writing CTRLA.ENABLE=0.

The FREQM is reset by writing a '1' to the Software Reset bit in the Control A register (CTRLA.SWRST). On software reset, all registers in the FREQM will be reset to their initial state, and the FREQM will be disabled.

Then ENABLE and SWRST bits are write-synchronized.

### Related Links

[30.6.7 Synchronization](#)

#### 30.6.2.3 Measurement

In the Configuration A register, the Number of Reference Clock Cycles field (CFG.A.REFNUM) selects the duration of the measurement. The measurement is given in number of GCLK\_FREQM\_REF periods.

**Note:** The REFNUM field must be written before the FREQM is enabled.

After the FREQM is enabled, writing a '1' to the START bit in the Control B register (CTRLB.START) starts the measurement. The BUSY bit in Status register (STATUS.BUSY) is set when the measurement starts, and cleared when the measurement is complete.

There is also an interrupt request for Measurement Done: When the Measurement Done bit in Interrupt Enable Set register (INTENSET.DONE) is '1' and a measurement is finished, the Measurement Done bit in the Interrupt Flag Status and Clear register (INTFLAG.DONE) will be set and an interrupt request is generated.

The result of the measurement can be read from the Value register (VALUE.VALUE). The frequency of the measured clock GCLK\_FREQM\_MSR is then:

$$f_{\text{CLK\_MSR}} = \left( \frac{\text{VALUE}}{\text{REFNUM}} \right) f_{\text{CLK\_REF}}$$

**Note:** In order to make sure the measurement result (VALUE.VALUE[23:0]) is valid, the overflow status (STATUS.OVF) should be checked.

In case an overflow condition occurred, indicated by the Overflow bit in the STATUS register (STATUS.OVF), either the number of reference clock cycles must be reduced (CFG.A.REFNUM), or a faster reference clock must be configured. Once the configuration is adjusted, clear the overflow status by writing a '1' to STATUS.OVF. Then another measurement can be started by writing a '1' to CTRLB.START.

#### 30.6.3 DMA Operation

Not applicable.

#### 30.6.4 Interrupts

The FREQM has one interrupt source:

- DONE: A frequency measurement is done.

The interrupt flag in the Interrupt Flag Status and Clear (30.8.6 INTFLAG) register is set when the interrupt condition occurs. The interrupt can be enabled by writing a '1' to the corresponding bit in the Interrupt Enable Set (30.8.5 INTENSET) register, and disabled by writing a '1' to the corresponding bit in the Interrupt Enable Clear (30.8.4 INTENCLR) register.

An interrupt request is generated when the interrupt flag is set and the corresponding interrupt is enabled. The interrupt request remains active until the interrupt flag is cleared, the interrupt is disabled, or the FREQM is reset. See 30.8.6 INTFLAG for details on how to clear interrupt flags. All interrupt requests from the peripheral are ORed together on system level to generate one combined interrupt request to the NVIC. The user must read the 30.8.6 INTFLAG register to determine which interrupt condition is present.

This interrupt is a synchronous wake-up source.

Note that interrupts must be globally enabled for interrupt requests to be generated.

### 30.6.5 Events

Not applicable.

### 30.6.6 Sleep Mode Operation

The FREQM will continue to operate in idle sleep mode where the selected source clock is running. The FREQM's interrupts can be used to wake up the device from idle sleep mode.

For lowest chip power consumption in sleep modes, FREQM should be disabled before entering a sleep mode.

#### Related Links

[18. PM – Power Manager](#)

### 30.6.7 Synchronization

Due to asynchronicity between the main clock domain and the peripheral clock domains, some registers need to be synchronized when written or read.

The following bits and registers are write-synchronized:

- Software Reset bit in Control A register (CTRLA.SWRST)
- Enable bit in Control A register (CTRLA.ENABLE)

Required write synchronization is denoted by the "Write-Synchronized" property in the register description.

#### Related Links

[13.3 Register Synchronization](#)

### 30.7 Register Summary

Offset	Name	Bit Pos.								
0x00	CTRLA	7:0						ENABLE	SWRST	
0x01	CTRLB	7:0							START	
0x02	CFGA	7:0	REFNUM[7:0]							
		15:8								
0x04 ... 0x07	Reserved									
0x08	INTENCLR	7:0							DONE	
0x09	INTENSET	7:0							DONE	
0x0A	INTFLAG	7:0							DONE	
0x0B	STATUS	7:0						OVF	BUSY	
0x0C	SYNCBUSY	7:0						ENABLE	SWRST	
		15:8								
		23:16								
		31:24								
0x10	VALUE	7:0	VALUE[7:0]							
		15:8	VALUE[15:8]							
		23:16	VALUE[23:16]							
		31:24								

### 30.8 Register Description

Registers can be 8, 16, or 32 bits wide. Atomic 8-, 16-, and 32-bit accesses are supported. In addition, the 8-bit quarters and 16-bit halves of a 32-bit register, and the 8-bit halves of a 16-bit register can be accessed directly.

Some registers require synchronization when read and/or written. Synchronization is denoted by the "Read-Synchronized" and/or "Write-Synchronized" property in each individual register description.

Some registers are enable-protected, meaning they can only be written when the module is disabled. Enable protection is denoted by the "Enable-Protected" property in each individual register description.

Some registers are optionally write-protected by the Peripheral Access Controller (PAC). Optional PAC write protection is denoted by the "PAC Write-Protection" property in each individual register description.

# SAM D5x/E5x Family Data Sheet

## FREQM – Frequency Meter

### 30.8.1 Control A

**Name:** CTRLA  
**Offset:** 0x00  
**Reset:** 0x00  
**Property:** PAC Write-Protection

	7	6	5	4	3	2	1	0
							ENABLE	SWRST
Access							R/W	R/W
Reset							0	0

#### Bit 1 – ENABLE Enable

Due to synchronization there is delay from writing CTRLA.ENABLE until the peripheral is enabled/disabled. The value written to CTRLA.ENABLE will read back immediately and the ENABLE bit in the Synchronization Busy register (SYNCBUSY.ENABLE) will be set. SYNCBUSY.ENABLE will be cleared when the operation is complete.

This bit is not enable-protected.

Value	Description
0	The peripheral is disabled.
1	The peripheral is enabled.

#### Bit 0 – SWRST Software Reset

Writing a '0' to this bit has no effect.

Writing a '1' to this bit resets all registers in the FREQM to their initial state, and the FREQM will be disabled. Writing a '1' to this bit will always take precedence, meaning that all other writes in the same write-operation will be discarded.

Due to synchronization there is a delay from writing CTRLA.SWRST until the Reset is complete.

CTRLA.SWRST and SYNCBUSY.SWRST will both be cleared when the Reset is complete.

This bit is not enable-protected.

Value	Description
0	There is no ongoing Reset operation.
1	The Reset operation is ongoing.

# SAM D5x/E5x Family Data Sheet

## FREQM – Frequency Meter

### 30.8.2 Control B

**Name:** CTRLB  
**Offset:** 0x01  
**Reset:** 0x00  
**Property:** –

Bit	7	6	5	4	3	2	1	0
								START
Access								W
Reset								0

#### Bit 0 – START Start Measurement

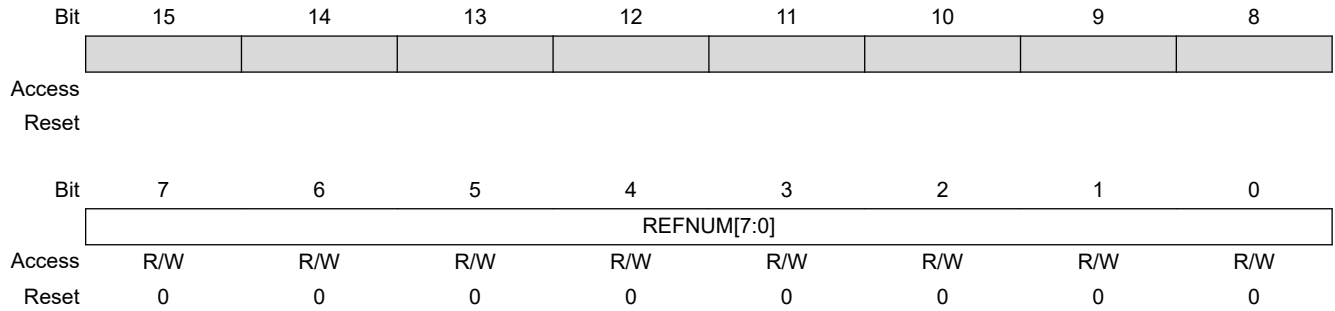
Value	Description
0	Writing a '0' has no effect.
1	Writing a '1' starts a measurement.

# SAM D5x/E5x Family Data Sheet

## FREQM – Frequency Meter

### 30.8.3 Configuration A

**Name:** CFGA  
**Offset:** 0x02  
**Reset:** 0x0000  
**Property:** PAC Write-Protection, Enable-protected



**Bits 7:0 – REFNUM[7:0]** Number of Reference Clock Cycles  
 Selects the duration of a measurement in number of CLK\_FREQM\_REF cycles. This must be a non-zero value, i.e. 0x01 (one cycle) to 0xFF (255 cycles).

### 30.8.4 Interrupt Enable Clear

**Name:** INTENCLR  
**Offset:** 0x08  
**Reset:** 0x00  
**Property:** PAC Write-Protection

	7		6		5		4		3		2		1		0															
	<table border="1" style="width: 100%; height: 20px; border-collapse: collapse;"> <tr> <td style="width: 10%;"></td> <td style="width: 10%;"></td> <td style="width: 10%;"></td> <td style="width: 10%;"></td> <td style="width: 10%;"></td> <td style="width: 10%;"></td> <td style="width: 10%;"></td> <td style="width: 10%;"></td> <td style="width: 10%;"></td> <td style="width: 10%;"></td> <td style="width: 10%;"></td> <td style="width: 10%;"></td> <td style="width: 10%;"></td> <td style="width: 10%;"></td> <td style="width: 10%;"></td> <td style="width: 10%; text-align: center;">DONE</td> </tr> </table>																													DONE
															DONE															
Access															R/W															
Reset															0															

**Bit 0 – DONE** Measurement Done Interrupt Enable

Writing a '0' to this bit has no effect.

Writing a '1' to this bit will clear the Measurement Done Interrupt Enable bit, which disables the Measurement Done interrupt.

Value	Description
0	The Measurement Done interrupt is disabled.
1	The Measurement Done interrupt is enabled.



### 30.8.5 Interrupt Enable Set

**Name:** INTENSET  
**Offset:** 0x09  
**Reset:** 0x00  
**Property:** PAC Write-Protection

Bit	7	6	5	4	3	2	1	0
								DONE
Access								R/W
Reset								0

**Bit 0 – DONE** Measurement Done Interrupt Enable

Writing a '0' to this bit has no effect.

Writing a '1' to this bit will set the Measurement Done Interrupt Enable bit, which enables the Measurement Done interrupt.

Value	Description
0	The Measurement Done interrupt is disabled.
1	The Measurement Done interrupt is enabled.

### 30.8.6 Interrupt Flag Status and Clear

**Name:** INTFLAG  
**Offset:** 0x0A  
**Reset:** 0x00  
**Property:** –

Bit	7	6	5	4	3	2	1	0
								DONE
Access								R/W
Reset								0

#### Bit 0 – DONE Measurement Done

This flag is cleared by writing a '1' to it.

This flag is set when the STATUS.BUSY bit has a one-to-zero transition.

Writing a '0' to this bit has no effect.

Writing a '1' to this bit will clear the DONE interrupt flag.

# SAM D5x/E5x Family Data Sheet

## FREQM – Frequency Meter

### 30.8.7 Status

**Name:** STATUS  
**Offset:** 0x0B  
**Reset:** 0x00  
**Property:** –

	7	6	5	4	3	2	1	0
							OVF	BUSY
Access							R/W	R
Reset							0	0

**Bit 1 – OVF** Sticky Count Value Overflow

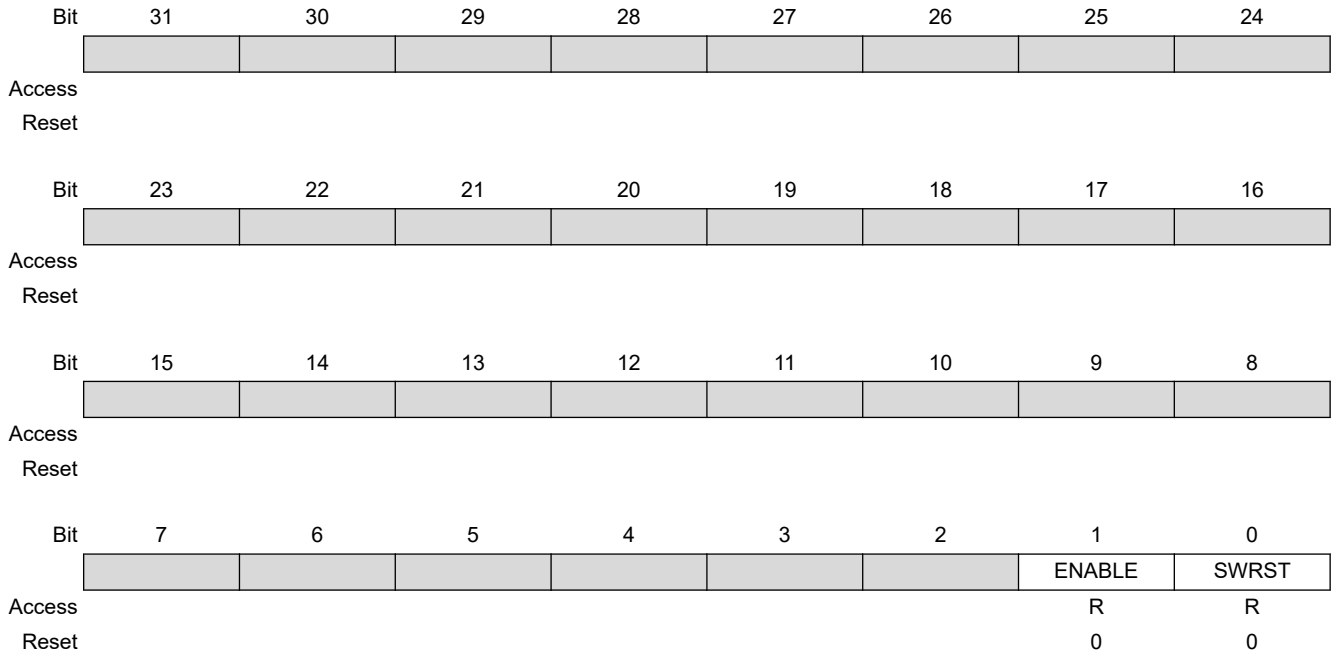
This bit is cleared by writing a '1' to it.  
 This bit is set when an overflow condition occurs to the value counter.  
 Writing a '0' to this bit has no effect.  
 Writing a '1' to this bit will clear the OVF status.

**Bit 0 – BUSY** FREQM Status

Value	Description
0	No ongoing frequency measurement.
1	Frequency measurement is ongoing.

### 30.8.8 Synchronization Busy

**Name:** SYNCBUSY  
**Offset:** 0x0C  
**Reset:** 0x00000000  
**Property:** –



**Bit 1 – ENABLE** Enable

This bit is cleared when the synchronization of CTRLA.ENABLE is complete.  
 This bit is set when the synchronization of CTRLA.ENABLE is started.

**Bit 0 – SWRST** Synchronization Busy

This bit is cleared when the synchronization of CTRLA.SWRST is complete.  
 This bit is set when the synchronization of CTRLA.SWRST is started.

# SAM D5x/E5x Family Data Sheet

## FREQM – Frequency Meter

### 30.8.9 Value

**Name:** VALUE  
**Offset:** 0x10  
**Reset:** 0x00000000  
**Property:** –

Bit	31	30	29	28	27	26	25	24
Access								
Reset								
Bit	23	22	21	20	19	18	17	16
	VALUE[23:16]							
Access	R	R	R	R	R	R	R	R
Reset	0	0	0	0	0	0	0	0
Bit	15	14	13	12	11	10	9	8
	VALUE[15:8]							
Access	R	R	R	R	R	R	R	R
Reset	0	0	0	0	0	0	0	0
Bit	7	6	5	4	3	2	1	0
	VALUE[7:0]							
Access	R	R	R	R	R	R	R	R
Reset	0	0	0	0	0	0	0	0

**Bits 23:0 – VALUE[23:0]** Measurement Value  
 Result from measurement.

## **31. EVSYS – Event System**

### **31.1 Overview**

The Event System (EVSYS) allows autonomous, low-latency and configurable communication between peripherals.

Several peripherals can be configured to generate and/or respond to signals known as events. The exact condition to generate an event, or the action taken upon receiving an event, is specific to each peripheral. Peripherals that respond to events are called event users. Peripherals that generate events are called event generators. A peripheral can have one or more event generators and can have one or more event users.

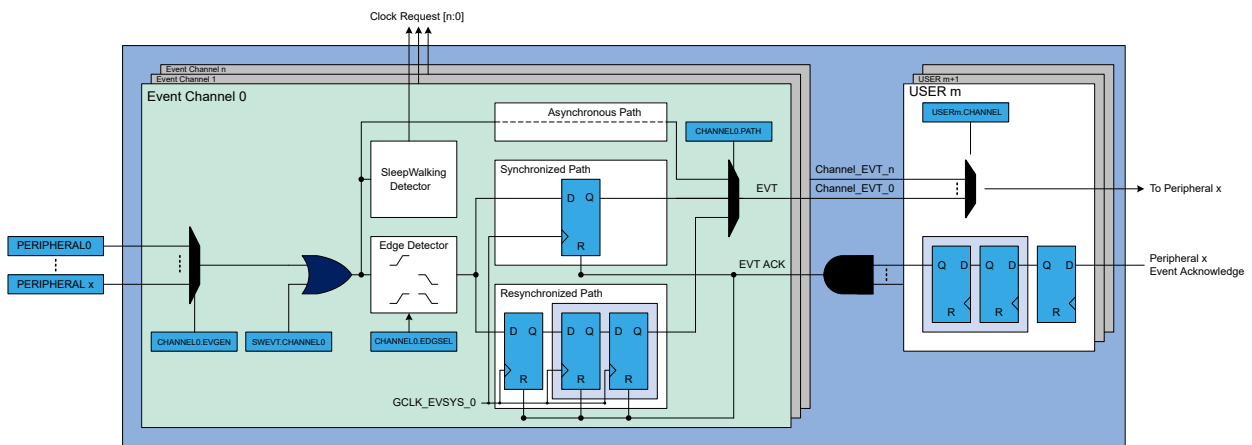
Communication is made without CPU intervention and without consuming system resources such as bus or RAM bandwidth. This reduces the load on the CPU and other system resources, compared to a traditional interrupt-based system.

### **31.2 Features**

- 32 configurable event channels:
  - All channels can be connected to any event generator
  - All channels provide a pure asynchronous path
  - 12 channels (CHANNEL0 to CHANNEL11) provide a resynchronized or synchronous path using their dedicated generic clock (GCLK\_EVSYS\_CHANNEL\_n)
- 119 event generators.
- 67 event users.
- Configurable edge detector.
- Peripherals can be event generators, event users, or both.
- SleepWalking and interrupt for operation in sleep modes.
- Software event generation.
- Each event user can choose which channel to respond to.
- Optional Static or Round-Robin interrupt priority arbitration.

### 31.3 Block Diagram

Figure 31-1. Event System Block Diagram



### 31.4 Product Dependencies

In order to use this peripheral, other parts of the system must be configured correctly, as described below.

#### 31.4.1 I/O Lines

Not applicable.

#### 31.4.2 Power Management

The EVSYS can be used to wake up the CPU from all sleep modes (except BACKUP and OFF Mode), even if the clock used by the EVSYS channel and the EVSYS bus clock are disabled. Refer to the *PM – Power Manager* for details on the different sleep modes.

Although the clock for the EVSYS is stopped, the device still can wake up the EVSYS clock. Some event generators can generate an event when their clocks are stopped. The generic clock for the channel (GCLK\_EVSYS\_CHANNEL\_n) will be restarted if that channel uses a synchronized path or a resynchronized path. It does not need to wake the system from sleep.



**Important:** This generic clock only applies to channels which can be configured as synchronous or resynchronized.

#### Related Links

[18. PM – Power Manager](#)

#### 31.4.3 Clocks

The EVSYS bus clock (CLK\_EVSYS\_APB) can be enabled and disabled in the Main Clock module, and the default state of CLK\_EVSYS\_APB can be found in *Peripheral Clock Masking*.

Each EVSYS channel which can be configured as synchronous or resynchronized has a dedicated generic clock (GCLK\_EVSYS\_CHANNEL\_n). These are used for event detection and propagation for each channel. These clocks must be configured and enabled in the generic clock controller before using the EVSYS. Refer to *GCLK - Generic Clock Controller* for details.



**Important:** Only EVSYS channel 0 to 11 can be configured as synchronous or resynchronized.

### Related Links

[15.6.2.6 Peripheral Clock Masking](#)

[14. GCLK - Generic Clock Controller](#)

#### 31.4.4 DMA

Not applicable.

#### 31.4.5 Interrupts

The interrupt request line is connected to the interrupt controller. Using the EVSYS interrupts requires the interrupt controller to be configured first. Refer to *Nested Vector Interrupt Controller* for details.

### Related Links

[10.2 Nested Vector Interrupt Controller](#)

#### 31.4.6 Events

Not applicable.

#### 31.4.7 Debug Operation

When the CPU is halted in Debug mode, this peripheral will continue normal operation. If the peripheral is configured to require periodical service by the CPU through interrupts or similar, improper operation or data loss may result during debugging. This peripheral can be forced to halt operation during debugging.

#### 31.4.8 Register Access Protection

Registers with write access can be optionally write-protected by the Peripheral Access Controller (PAC), except for the following:

- Channel Pending Interrupt (INTPEND)
- Channel n Interrupt Flag Status and Clear (CHINTFLAGn)

**Note:** Optional write protection is indicated by the "PAC Write Protection" property in the register description.

Write protection does not apply for accesses through an external debugger.

#### 31.4.9 Analog Connections

Not applicable.

## 31.5 Functional Description

### 31.5.1 Principle of Operation

The Event System consists of several channels which route the internal events from peripherals (generators) to other internal peripherals or I/O pins (users). Each event generator can be selected as source for multiple channels, but a channel cannot be set to use multiple event generators at the same time.

A channel path can be configured in asynchronous, synchronous or resynchronized mode of operation. The mode of operation must be selected based on the requirements of the application.



When using synchronous or resynchronized path, the Event System includes options to transfer events to users when rising, falling or both edges are detected on event generators.

For further details, refer to the Channel Path section of this chapter.

### Related Links

[31.5.2.6 Channel Path](#)

## 31.5.2 Basic Operation

### 31.5.2.1 Initialization

Before enabling event routing within the system, the Event Users Multiplexer and Event Channels must be selected in the Event System (EVSYS), and the two peripherals that generate and use the event have to be configured. The recommended sequence is:

1. In the event generator peripheral, enable output of event by writing a '1' to the respective Event Output Enable bit ("EO") in the peripheral's Event Control register (e.g., TCC.EVCTRL.MCEO1, AC.EVCTRL.WINEO0, RTC.EVCTRL.OVFEO).
2. Configure the EVSYS:
  - 2.1. Configure the Event User multiplexer by writing the respective EVSYS.USERm register, see also [31.5.2.3 User Multiplexer Setup](#).
  - 2.2. Configure the Event Channel by writing the respective EVSYS.CHANNELn register, see also [31.5.2.4 Event System Channel](#).
3. Configure the action to be executed by the event user peripheral by writing to the Event Action bits (EVACTION) in the respective Event control register (e.g., TC.EVCTRL.EVACTION, PDEC.EVCTRL.EVACTION). Note: not all peripherals require this step.
4. In the event user peripheral, enable event input by writing a '1' to the respective Event Input Enable bit ("EI") in the peripheral's Event Control register (e.g., AC.EVCTRL.IVEIO, ADC.EVCTRL.STARTEI).

### 31.5.2.2 Enabling, Disabling, and Resetting

The EVSYS is always enabled.

The EVSYS is reset by writing a '1' to the Software Reset bit in the Control A register (CTRLA.SWRST). All registers in the EVSYS will be reset to their initial state and all ongoing events will be canceled.

Refer to [CTRLA.SWRST](#) register for details.

### 31.5.2.3 User Multiplexer Setup

The user multiplexer defines the channel to be connected to which event user. Each user multiplexer is dedicated to one event user. A user multiplexer receives all event channels output and must be configured to select one of these channels, as shown in Block Diagram section. The channel is selected with the Channel bit group in the User register (USERm.CHANNEL).

The user multiplexer must always be configured before the channel. A list of all user multiplexers is found in the User (USERm) register description.

### Related Links

[31.3 Block Diagram](#)

### 31.5.2.4 Event System Channel

An event channel can select one event from a list of event generators. Depending on configuration, the selected event could be synchronized, resynchronized or asynchronously sent to the users. When synchronization or resynchronization is required, the channel includes an internal edge detector, allowing

the Event System to generate internal events when rising, falling or both edges are detected on the selected event generator.

An event channel is able to generate internal events for the specific software commands. A channel block diagram is shown in *Block Diagram* section.

### Related Links

[31.3 Block Diagram](#)

#### 31.5.2.5 Event Generators

Each event channel can receive the events from all event generators. All event generators are listed in the Event Generator bit field in the Channel n register (CHANNELn.EVGEN). For details on event generation, refer to the corresponding module chapter. The channel event generator is selected by the Event Generator bit group in the Channel register (CHANNELn.EVGEN). By default, the channels are not connected to any event generators (ie, CHANNELn.EVGEN = 0)

#### 31.5.2.6 Channel Path

There are different ways to propagate the event from an event generator:

- Asynchronous path
- Synchronous path
- Resynchronized path

The path is decided by writing to the Path Selection bit group of the Channel register (CHANNELn.PATH).

#### Asynchronous Path

When using the asynchronous path, the events are propagated from the event generator to the event user without intervention from the Event System. The GCLK for this channel (GCLK\_EVSYS\_CHANNEL\_n) is not mandatory, meaning that an event will be propagated to the user without any clock latency.

When the asynchronous path is selected, the channel cannot generate any interrupts, and the Channel x Status register (CHSTATUSx) is always zero. The edge detection is not required and must be disabled by software. Each peripheral event user has to select which event edge must trigger internal actions. For further details, refer to each peripheral chapter description.

#### Synchronous Path

The synchronous path should be used when the event generator and the event channel share the same generator for the generic clock. If they do not share the same clock, a logic change from the event generator to the event channel might not be detected in the channel, which means that the event will not be propagated to the event user.

When using the synchronous path, the channel is able to generate interrupts. The channel status bits in the Channel Status register (CHSTATUS) are also updated and available for use.

#### Resynchronized Path

The resynchronized path are used when the event generator and the event channel do not share the same generator for the generic clock. When the resynchronized path is used, resynchronization of the event from the event generator is done in the channel.

When the resynchronized path is used, the channel is able to generate interrupts. The channel status bits in the Channel Status register (CHSTATUS) are also updated and available for use.

### 31.5.2.7 Edge Detection

When synchronous or resynchronized paths are used, edge detection must be enabled. The event system can execute edge detection in three different ways:

- Generate an event only on the rising edge
- Generate an event only on the falling edge
- Generate an event on rising and falling edges.

Edge detection is selected by writing to the Edge Selection bit group of the Channel register (CHANNELn.EDGSEL).

### 31.5.2.8 Event Latency

An event from an event generator is propagated to an event user with different latency, depending on event channel configuration.

- Asynchronous Path: The maximum routing latency of an external event is related to the internal signal routing and it is device dependent.
- Synchronous Path: The maximum routing latency of an external event is one GCLK\_EVSYS\_CHANNEL\_n clock cycle.
- Resynchronized Path: The maximum routing latency of an external event is three GCLK\_EVSYS\_CHANNEL\_n clock cycles.

The maximum propagation latency of a user event to the peripheral clock core domain is three peripheral clock cycles.

The event generators, event channel and event user clocks ratio must be selected in relation with the internal event latency constraints. Events propagation or event actions in peripherals may be lost if the clock setup violates the internal latencies.

### 31.5.2.9 The Overrun Channel n Interrupt

The Overrun Channel n Interrupt flag in the Interrupt Flag Status and Clear register (CHINTFLAGn.OVR) will be set, and the optional interrupt will be generated in the following cases:

- One or more event users on channel n is not ready when there is a new event
- An event occurs when the previous event on channel m has not been handled by all event users connected to that channel

The flag will only be set when using synchronous or resynchronized paths. In the case of asynchronous path, the CHINTFLAGn.OVR is always read as zero.

### 31.5.2.10 The Event Detected Channel n Interrupt

The Event Detected Channel n Interrupt flag in the Interrupt Flag Status and Clear register (CHINTFLAGn.EVD) is set when an event coming from the event generator configured on channel n is detected.

The flag will only be set when using a synchronous or resynchronized path. In the case of an asynchronous path, the CHINTFLAGn.EVD is always zero.

### 31.5.2.11 Channel Status

The Channel Status register (CHSTATUS) shows the status of the channels when using a synchronous or resynchronized path. There are two different status bits in CHSTATUS for each of the available channels:

- The CHSTATUSn.BUSYCH bit will be set when an event on the corresponding channel n has not been handled by all event users connected to that channel.
- The CHSTATUSn.RDYUSR bit will be set when all event users connected to the corresponding channel are ready to handle incoming events on that channel.

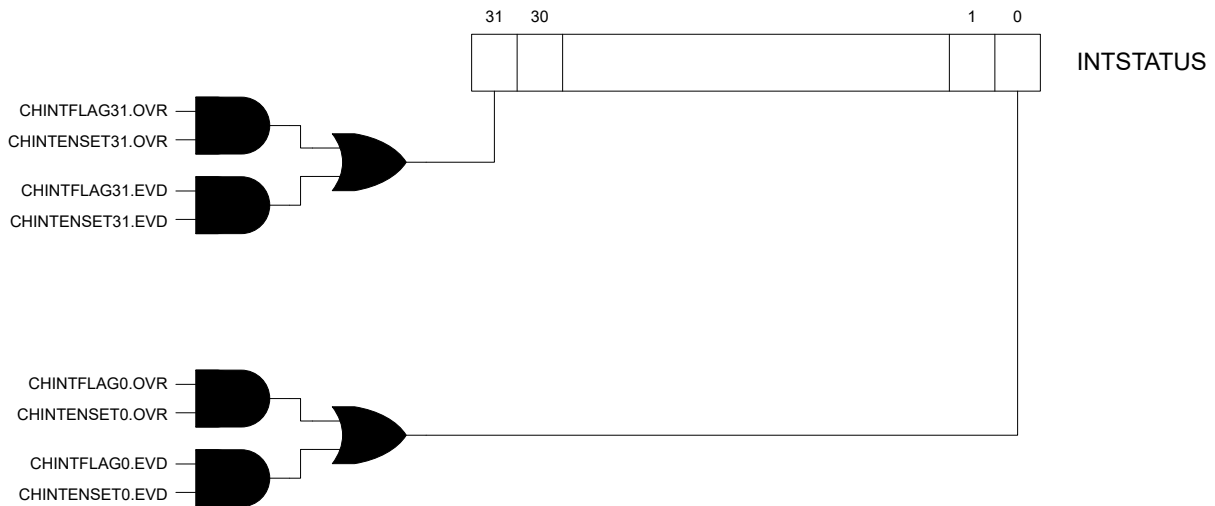
### 31.5.2.12 Software Event

A software event can be initiated on a channel by writing a '1' to the Software Event bit in the Channel register (CHANNELm.SWEVT). Then the software event can be serviced as any event generator; i.e., when the bit is set to '1', an event will be generated on the respective channel.

### 31.5.2.13 Interrupt Status and Interrupts Arbitration

The Interrupt Status register stores all channels with pending interrupts, as shown below.

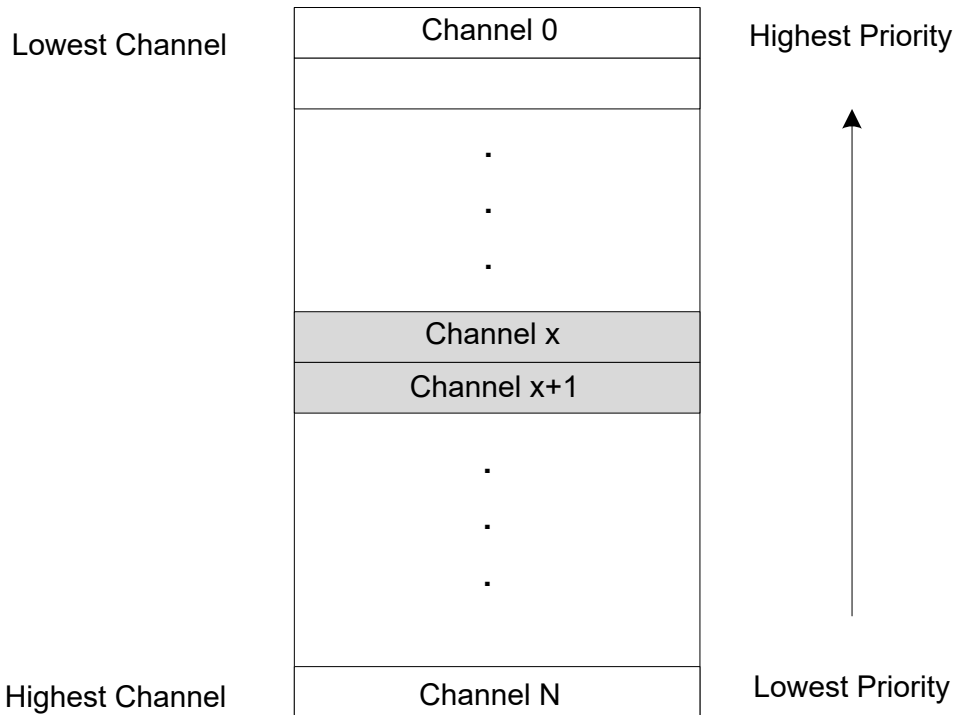
**Figure 31-2. Interrupt Status Register**



The Event System can arbitrate between all channels with pending interrupts. The arbiter can be configured to prioritize statically or dynamically the incoming events. The priority is evaluated each time a new channel has an interrupt pending, or an interrupt has been cleared. The Channel Pending Interrupt register (INTPEND) will provide the channel number with the highest interrupt priority, and the corresponding channel interrupt flags and status bits.

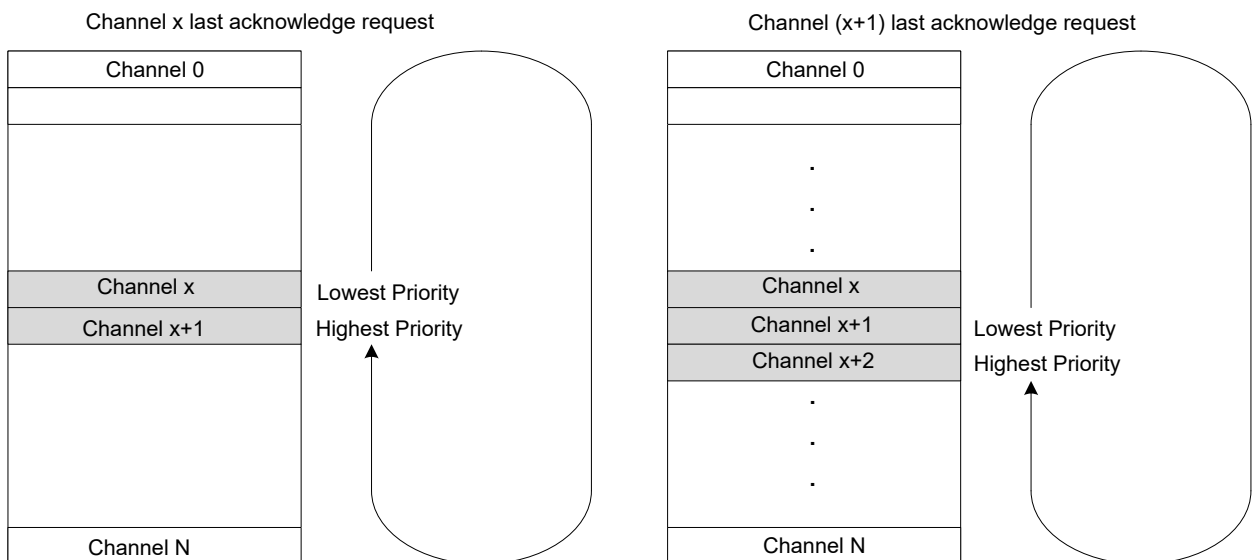
By default, static arbitration is enabled (PRICTRL.RRENx is '0'), the arbiter will prioritize a low channel number over a high channel number as shown below. When using the status scheme, there is a risk of high channel numbers never being granted access by the arbiter. This can be avoided using a dynamic arbitration scheme.

**Figure 31-3. Static Priority**



The dynamic arbitration scheme available in the Event System is round-robin. Round-robin arbitration is enabled by writing `PRICTRL.RREN` to one. With the round-robin scheme, the channel number of the last channel being granted access will have the lowest priority the next time the arbiter has to grant access to a channel, as shown below. The channel number of the last channel being granted access, will be stored in the Channel Priority Number bit group in the Priority Control register (`PRICTRL.PRI`).

**Figure 31-4. Round-Robin Scheduling**



The Channel Pending Interrupt register (`INTPEND`) also offers the possibility to indirectly clear the interrupt flags of a specific channel. Writing a flag to one in this register, will clear the corresponding interrupt flag of the channel specified by the `INTPEND.ID` bits.

### 31.5.3 Interrupts

The EVSYS has the following interrupt sources for each channel:

- Overrun Channel n interrupt (OVR)
- Event Detected Channel n interrupt (EVD)

These interrupts events are asynchronous wake-up sources.

Each interrupt source has an interrupt flag associated with it. The interrupt flag in the corresponding Channel n Interrupt Flag Status and Clear (CHINTFLAG) register is set when the interrupt condition occurs.

**Note:** Interrupts must be globally enabled to allow the generation of interrupt requests.

Each interrupt can be individually enabled by writing a '1' to the corresponding bit in the Channel n Interrupt Enable Set (CHINTENSET) register, and disabled by writing a '1' to the corresponding bit in the Channel n Interrupt Enable Clear (CHINTENCLR) register. An interrupt request is generated when the interrupt flag is set and the corresponding interrupt is enabled. The interrupt request remains active until the interrupt flag is cleared, the interrupt is disabled or the Event System is reset. All interrupt requests are ORed together on system level to generate one combined interrupt request to the NVIC.

The user must read the Channel Interrupt Status (INTSTATUS) register to identify the channels with pending interrupts, and must read the Channel n Interrupt Flag Status and Clear (CHINTFLAG) register to determine which interrupt condition is present for the corresponding channel. It is also possible to read the Interrupt Pending register (INTPEND), which provides the highest priority channel with pending interrupt and the respective interrupt flags.

### 31.5.4 Sleep Mode Operation

The Event System can generate interrupts to wake up the device from IDLE or STANDBY sleep mode.

To be able to run in standby, the Run in Standby bit in the Channel register (CHANNELn.RUNSTDBY) must be set to '1'. When the Generic Clock On Demand bit in Channel register (CHANNELn.ONDEMAND) is set to '1' and the event generator is detected, the event channel will request its clock (GCLK\_EVSYS\_CHANNEL\_n). The event latency for a resynchronized channel path will increase by two GCLK\_EVSYS\_CHANNEL\_n clock (i.e., up to five GCLK\_EVSYS\_CHANNEL\_n clock cycles).

A channel will behave differently in different sleep modes regarding to CHANNELn.RUNSTDBY and CHANNELn.ONDEMAND:

**Table 31-1. Event Channel Sleep Behavior**

CHANNELn.PATH	CHANNELn.ONDEMAND	CHANNELn.RUNSTDBY	Sleep Behavior
ASYNCH	0	0	Only run in IDLE sleep modes if an event must be propagated. Disabled in STANDBY sleep mode.
SYNC/RESYNC	0	1	Run in both IDLE and STANDBY sleep modes.

# SAM D5x/E5x Family Data Sheet

## EVSYS – Event System

.....continued

CHANNELn.PATH	CHANNELn.ONDEMAND	CHANNELn.RUNSTDBY	Sleep Behavior
SYNC/RESYNC	1	0	Only run in IDLE sleep modes if an event must be propagated. Disabled in STANDBY sleep mode. Two GCLK_EVSYS_n latency added in RESYNC path before the event is propagated internally.
SYNC/RESYNC	1	1	Run in both IDLE and STANDBY sleep modes. Two GCLK_EVSYS_n latency added in RESYNC path before the event is propagated internally.

# SAM D5x/E5x Family Data Sheet

## EVSYS – Event System

### 31.6 Register Summary

Offset	Name	Bit Pos.									
0x00	<b>CTRLA</b>	7:0								SWRST	
0x01 ... 0x03	Reserved										
0x04	<b>SWEVT</b>	7:0	CHANNEL7	CHANNEL6	CHANNEL5	CHANNEL4	CHANNEL3	CHANNEL2	CHANNEL1	CHANNEL0	
		15:8	CHANNEL15	CHANNEL14	CHANNEL13	CHANNEL12	CHANNEL11	CHANNEL10	CHANNEL9	CHANNEL8	
		23:16	CHANNEL23	CHANNEL22	CHANNEL21	CHANNEL20	CHANNEL19	CHANNEL18	CHANNEL17	CHANNEL16	
		31:24	CHANNEL31	CHANNEL30	CHANNEL29	CHANNEL28	CHANNEL27	CHANNEL26	CHANNEL25	CHANNEL24	
0x08	<b>PRICTRL</b>	7:0	RREN				PRI[4:0]				
0x09 ... 0x0F	Reserved										
0x10	<b>INTPEND</b>	7:0					ID[4:0]				
		15:8	BUSY	READY					EVD	OVR	
0x12 ... 0x13	Reserved										
0x14	<b>INTSTATUS</b>	7:0	CHINT7	CHINT6	CHINT5	CHINT4	CHINT3	CHINT2	CHINT1	CHINT0	
		15:8					CHINT11	CHINT10	CHINT9	CHINT8	
		23:16									
		31:24									
0x18	<b>BUSYCH</b>	7:0	BUSYCHx7	BUSYCHx6	BUSYCHx5	BUSYCHx4	BUSYCHx3	BUSYCHx2	BUSYCHx1	BUSYCHx0	
		15:8					BUSYCHx11	BUSYCHx10	BUSYCHx9	BUSYCHx8	
		23:16									
		31:24									
0x1C	<b>READYUSR</b>	7:0	READYUSR7	READYUSR6	READYUSR5	READYUSR4	READYUSR3	READYUSR2	READYUSR1	READYUSR0	
		15:8					READYUSR1	READYUSR1	READYUSR9	READYUSR8	
		23:16					1	0			
		31:24									
0x20	<b>CHANNEL0</b>	7:0	EVGEN[7:0]								
		15:8	ONDEMAND	RUNSTDBY				EDGSEL[1:0]		PATH[1:0]	
		23:16									
		31:24									
0x24	<b>CHINTENCLR0</b>	7:0							EVD	OVR	
0x25	<b>CHINTENSET0</b>	7:0							EVD	OVR	
0x26	<b>CHINTFLAG0</b>	7:0							EVD	OVR	
0x27	<b>CHSTATUS0</b>	7:0							BUSYCH	RDYUSR	
0x28	<b>CHANNEL1</b>	7:0	EVGEN[7:0]								
		15:8	ONDEMAND	RUNSTDBY				EDGSEL[1:0]		PATH[1:0]	
		23:16									
		31:24									
0x2C	<b>CHINTENCLR1</b>	7:0							EVD	OVR	



# SAM D5x/E5x Family Data Sheet

## EVSYS – Event System

.....continued

Offset	Name	Bit Pos.									
0x2D	CHINTENSET1	7:0							EVD	OVR	
0x2E	CHINTFLAG1	7:0							EVD	OVR	
0x2F	CHSTATUS1	7:0							BUSYCH	RDYUSR	
0x30	CHANNEL2	7:0	EVGEN[7:0]								
		15:8	ONDEMAND	RUNSTDBY				EDGSEL[1:0]	PATH[1:0]		
		23:16									
		31:24									
0x34	CHINTENCLR2	7:0						EVD	OVR		
0x35	CHINTENSET2	7:0						EVD	OVR		
0x36	CHINTFLAG2	7:0						EVD	OVR		
0x37	CHSTATUS2	7:0						BUSYCH	RDYUSR		
0x38	CHANNEL3	7:0	EVGEN[7:0]								
		15:8	ONDEMAND	RUNSTDBY				EDGSEL[1:0]	PATH[1:0]		
		23:16									
		31:24									
0x3C	CHINTENCLR3	7:0						EVD	OVR		
0x3D	CHINTENSET3	7:0						EVD	OVR		
0x3E	CHINTFLAG3	7:0						EVD	OVR		
0x3F	CHSTATUS3	7:0						BUSYCH	RDYUSR		
0x40	CHANNEL4	7:0	EVGEN[7:0]								
		15:8	ONDEMAND	RUNSTDBY				EDGSEL[1:0]	PATH[1:0]		
		23:16									
		31:24									
0x44	CHINTENCLR4	7:0						EVD	OVR		
0x45	CHINTENSET4	7:0						EVD	OVR		
0x46	CHINTFLAG4	7:0						EVD	OVR		
0x47	CHSTATUS4	7:0						BUSYCH	RDYUSR		
0x48	CHANNEL5	7:0	EVGEN[7:0]								
		15:8	ONDEMAND	RUNSTDBY				EDGSEL[1:0]	PATH[1:0]		
		23:16									
		31:24									
0x4C	CHINTENCLR5	7:0						EVD	OVR		
0x4D	CHINTENSET5	7:0						EVD	OVR		
0x4E	CHINTFLAG5	7:0						EVD	OVR		
0x4F	CHSTATUS5	7:0						BUSYCH	RDYUSR		
0x50	CHANNEL6	7:0	EVGEN[7:0]								
		15:8	ONDEMAND	RUNSTDBY				EDGSEL[1:0]	PATH[1:0]		
		23:16									
		31:24									
0x54	CHINTENCLR6	7:0						EVD	OVR		
0x55	CHINTENSET6	7:0						EVD	OVR		
0x56	CHINTFLAG6	7:0						EVD	OVR		
0x57	CHSTATUS6	7:0						BUSYCH	RDYUSR		

# SAM D5x/E5x Family Data Sheet

## EVSYS – Event System

.....continued

Offset	Name	Bit Pos.								
0x58	CHANNEL7	7:0	EVGEN[7:0]							
		15:8	ONDEMAND	RUNSTDBY				EDGSEL[1:0]	PATH[1:0]	
		23:16								
		31:24								
0x5C	CHINTENCLR7	7:0						EVD	OVR	
0x5D	CHINTENSET7	7:0						EVD	OVR	
0x5E	CHINTFLAG7	7:0						EVD	OVR	
0x5F	CHSTATUS7	7:0						BUSYCH	RDYUSR	
0x60	CHANNEL8	7:0	EVGEN[7:0]							
		15:8	ONDEMAND	RUNSTDBY				EDGSEL[1:0]	PATH[1:0]	
		23:16								
		31:24								
0x64	CHINTENCLR8	7:0						EVD	OVR	
0x65	CHINTENSET8	7:0						EVD	OVR	
0x66	CHINTFLAG8	7:0						EVD	OVR	
0x67	CHSTATUS8	7:0						BUSYCH	RDYUSR	
0x68	CHANNEL9	7:0	EVGEN[7:0]							
		15:8	ONDEMAND	RUNSTDBY				EDGSEL[1:0]	PATH[1:0]	
		23:16								
		31:24								
0x6C	CHINTENCLR9	7:0						EVD	OVR	
0x6D	CHINTENSET9	7:0						EVD	OVR	
0x6E	CHINTFLAG9	7:0						EVD	OVR	
0x6F	CHSTATUS9	7:0						BUSYCH	RDYUSR	
0x70	CHANNEL10	7:0	EVGEN[7:0]							
		15:8	ONDEMAND	RUNSTDBY				EDGSEL[1:0]	PATH[1:0]	
		23:16								
		31:24								
0x74	CHINTENCLR10	7:0						EVD	OVR	
0x75	CHINTENSET10	7:0						EVD	OVR	
0x76	CHINTFLAG10	7:0						EVD	OVR	
0x77	CHSTATUS10	7:0						BUSYCH	RDYUSR	
0x78	CHANNEL11	7:0	EVGEN[7:0]							
		15:8	ONDEMAND	RUNSTDBY				EDGSEL[1:0]	PATH[1:0]	
		23:16								
		31:24								
0x7C	CHINTENCLR11	7:0						EVD	OVR	
0x7D	CHINTENSET11	7:0						EVD	OVR	
0x7E	CHINTFLAG11	7:0						EVD	OVR	
0x7F	CHSTATUS11	7:0						BUSYCH	RDYUSR	
0x80	CHANNEL12	7:0	EVGEN[7:0]							
		15:8	ONDEMAND	RUNSTDBY				EDGSEL[1:0]	PATH[1:0]	
		23:16								
		31:24								
0x84	CHINTENCLR12	7:0						EVD	OVR	

# SAM D5x/E5x Family Data Sheet

## EVSYS – Event System

.....continued

Offset	Name	Bit Pos.										
0x85	CHINTENSET12	7:0							EVD	OVR		
0x86	CHINTFLAG12	7:0							EVD	OVR		
0x87	CHSTATUS12	7:0							BUSYCH	RDYUSR		
0x88	CHANNEL13	7:0	EVGEN[7:0]									
		15:8	ONDEMAND	RUNSTDBY					EDGSEL[1:0]	PATH[1:0]		
		23:16										
		31:24										
0x8C	CHINTENCLR13	7:0							EVD	OVR		
0x8D	CHINTENSET13	7:0							EVD	OVR		
0x8E	CHINTFLAG13	7:0							EVD	OVR		
0x8F	CHSTATUS13	7:0							BUSYCH	RDYUSR		
0x90	CHANNEL14	7:0	EVGEN[7:0]									
		15:8	ONDEMAND	RUNSTDBY					EDGSEL[1:0]	PATH[1:0]		
		23:16										
		31:24										
0x94	CHINTENCLR14	7:0							EVD	OVR		
0x95	CHINTENSET14	7:0							EVD	OVR		
0x96	CHINTFLAG14	7:0							EVD	OVR		
0x97	CHSTATUS14	7:0							BUSYCH	RDYUSR		
0x98	CHANNEL15	7:0	EVGEN[7:0]									
		15:8	ONDEMAND	RUNSTDBY					EDGSEL[1:0]	PATH[1:0]		
		23:16										
		31:24										
0x9C	CHINTENCLR15	7:0							EVD	OVR		
0x9D	CHINTENSET15	7:0							EVD	OVR		
0x9E	CHINTFLAG15	7:0							EVD	OVR		
0x9F	CHSTATUS15	7:0							BUSYCH	RDYUSR		
0xA0	CHANNEL16	7:0	EVGEN[7:0]									
		15:8	ONDEMAND	RUNSTDBY					EDGSEL[1:0]	PATH[1:0]		
		23:16										
		31:24										
0xA4	CHINTENCLR16	7:0							EVD	OVR		
0xA5	CHINTENSET16	7:0							EVD	OVR		
0xA6	CHINTFLAG16	7:0							EVD	OVR		
0xA7	CHSTATUS16	7:0							BUSYCH	RDYUSR		
0xA8	CHANNEL17	7:0	EVGEN[7:0]									
		15:8	ONDEMAND	RUNSTDBY					EDGSEL[1:0]	PATH[1:0]		
		23:16										
		31:24										
0xAC	CHINTENCLR17	7:0							EVD	OVR		
0xAD	CHINTENSET17	7:0							EVD	OVR		
0xAE	CHINTFLAG17	7:0							EVD	OVR		
0xAF	CHSTATUS17	7:0							BUSYCH	RDYUSR		

# SAM D5x/E5x Family Data Sheet

## EVSYS – Event System

.....continued

Offset	Name	Bit Pos.								
0xB0	CHANNEL18	7:0	EVGEN[7:0]							
		15:8	ONDEMAND	RUNSTDBY				EDGSEL[1:0]	PATH[1:0]	
		23:16								
		31:24								
0xB4	CHINTENCLR18	7:0						EVD	OVR	
0xB5	CHINTENSET18	7:0						EVD	OVR	
0xB6	CHINTFLAG18	7:0						EVD	OVR	
0xB7	CHSTATUS18	7:0						BUSYCH	RDYUSR	
0xB8	CHANNEL19	7:0	EVGEN[7:0]							
		15:8	ONDEMAND	RUNSTDBY				EDGSEL[1:0]	PATH[1:0]	
		23:16								
		31:24								
0xBC	CHINTENCLR19	7:0						EVD	OVR	
0xBD	CHINTENSET19	7:0						EVD	OVR	
0xBE	CHINTFLAG19	7:0						EVD	OVR	
0xBF	CHSTATUS19	7:0						BUSYCH	RDYUSR	
0xC0	CHANNEL20	7:0	EVGEN[7:0]							
		15:8	ONDEMAND	RUNSTDBY				EDGSEL[1:0]	PATH[1:0]	
		23:16								
		31:24								
0xC4	CHINTENCLR20	7:0						EVD	OVR	
0xC5	CHINTENSET20	7:0						EVD	OVR	
0xC6	CHINTFLAG20	7:0						EVD	OVR	
0xC7	CHSTATUS20	7:0						BUSYCH	RDYUSR	
0xC8	CHANNEL21	7:0	EVGEN[7:0]							
		15:8	ONDEMAND	RUNSTDBY				EDGSEL[1:0]	PATH[1:0]	
		23:16								
		31:24								
0xCC	CHINTENCLR21	7:0						EVD	OVR	
0xCD	CHINTENSET21	7:0						EVD	OVR	
0xCE	CHINTFLAG21	7:0						EVD	OVR	
0xCF	CHSTATUS21	7:0						BUSYCH	RDYUSR	
0xD0	CHANNEL22	7:0	EVGEN[7:0]							
		15:8	ONDEMAND	RUNSTDBY				EDGSEL[1:0]	PATH[1:0]	
		23:16								
		31:24								
0xD4	CHINTENCLR22	7:0						EVD	OVR	
0xD5	CHINTENSET22	7:0						EVD	OVR	
0xD6	CHINTFLAG22	7:0						EVD	OVR	
0xD7	CHSTATUS22	7:0						BUSYCH	RDYUSR	
0xD8	CHANNEL23	7:0	EVGEN[7:0]							
		15:8	ONDEMAND	RUNSTDBY				EDGSEL[1:0]	PATH[1:0]	
		23:16								
		31:24								
0xDC	CHINTENCLR23	7:0						EVD	OVR	

# SAM D5x/E5x Family Data Sheet

## EVSYS – Event System

.....continued										
Offset	Name	Bit Pos.								
0xDD	CHINTENSET23	7:0							EVD OVR	
0xDE	CHINTFLAG23	7:0							EVD OVR	
0xDF	CHSTATUS23	7:0							BUSYCH RDYUSR	
0xE0	CHANNEL24	7:0	EVGEN[7:0]							
		15:8	ONDEMAND	RUNSTDBY				EDGSEL[1:0]	PATH[1:0]	
		23:16								
		31:24								
0xE4	CHINTENCLR24	7:0						EVD OVR		
0xE5	CHINTENSET24	7:0						EVD OVR		
0xE6	CHINTFLAG24	7:0						EVD OVR		
0xE7	CHSTATUS24	7:0						BUSYCH RDYUSR		
0xE8	CHANNEL25	7:0	EVGEN[7:0]							
		15:8	ONDEMAND	RUNSTDBY				EDGSEL[1:0]	PATH[1:0]	
		23:16								
		31:24								
0xEC	CHINTENCLR25	7:0						EVD OVR		
0xED	CHINTENSET25	7:0						EVD OVR		
0xEE	CHINTFLAG25	7:0						EVD OVR		
0xEF	CHSTATUS25	7:0						BUSYCH RDYUSR		
0xF0	CHANNEL26	7:0	EVGEN[7:0]							
		15:8	ONDEMAND	RUNSTDBY				EDGSEL[1:0]	PATH[1:0]	
		23:16								
		31:24								
0xF4	CHINTENCLR26	7:0						EVD OVR		
0xF5	CHINTENSET26	7:0						EVD OVR		
0xF6	CHINTFLAG26	7:0						EVD OVR		
0xF7	CHSTATUS26	7:0						BUSYCH RDYUSR		
0xF8	CHANNEL27	7:0	EVGEN[7:0]							
		15:8	ONDEMAND	RUNSTDBY				EDGSEL[1:0]	PATH[1:0]	
		23:16								
		31:24								
0xFC	CHINTENCLR27	7:0						EVD OVR		
0xFD	CHINTENSET27	7:0						EVD OVR		
0xFE	CHINTFLAG27	7:0						EVD OVR		
0xFF	CHSTATUS27	7:0						BUSYCH RDYUSR		
0x0100	CHANNEL28	7:0	EVGEN[7:0]							
		15:8	ONDEMAND	RUNSTDBY				EDGSEL[1:0]	PATH[1:0]	
		23:16								
		31:24								
0x0104	CHINTENCLR28	7:0						EVD OVR		
0x0105	CHINTENSET28	7:0						EVD OVR		
0x0106	CHINTFLAG28	7:0						EVD OVR		
0x0107	CHSTATUS28	7:0						BUSYCH RDYUSR		

# SAM D5x/E5x Family Data Sheet

## EVSYS – Event System

.....continued											
Offset	Name	Bit Pos.									
0x0108	CHANNEL29	7:0	EVGEN[7:0]								
		15:8	ONDEMAND	RUNSTDBY				EDGSEL[1:0]	PATH[1:0]		
		23:16									
		31:24									
0x010C	CHINTENCLR29	7:0						EVD	OVR		
0x010D	CHINTENSET29	7:0						EVD	OVR		
0x010E	CHINTFLAG29	7:0						EVD	OVR		
0x010F	CHSTATUS29	7:0						BUSYCH	RDYUSR		
0x0110	CHANNEL30	7:0	EVGEN[7:0]								
		15:8	ONDEMAND	RUNSTDBY				EDGSEL[1:0]	PATH[1:0]		
		23:16									
		31:24									
0x0114	CHINTENCLR30	7:0						EVD	OVR		
0x0115	CHINTENSET30	7:0						EVD	OVR		
0x0116	CHINTFLAG30	7:0						EVD	OVR		
0x0117	CHSTATUS30	7:0						BUSYCH	RDYUSR		
0x0118	CHANNEL31	7:0	EVGEN[7:0]								
		15:8	ONDEMAND	RUNSTDBY				EDGSEL[1:0]	PATH[1:0]		
		23:16									
		31:24									
0x011C	CHINTENCLR31	7:0						EVD	OVR		
0x011D	CHINTENSET31	7:0						EVD	OVR		
0x011E	CHINTFLAG31	7:0						EVD	OVR		
0x011F	CHSTATUS31	7:0						BUSYCH	RDYUSR		
0x0120	USER0	7:0	CHANNEL[7:0]								
		15:8									
		23:16									
		31:24									
...											
0x0228	USER66	7:0	CHANNEL[7:0]								
		15:8									
		23:16									
		31:24									

### 31.7 Register Description

Registers can be 8, 16, or 32 bits wide. Atomic 8-, 16-, and 32-bit accesses are supported. In addition, the 8-bit quarters and 16-bit halves of a 32-bit register, and the 8-bit halves of a 16-bit register can be accessed directly.

Optional write protection by the Peripheral Access Controller (PAC) is denoted by the "PAC Write Protection" property in each individual register description.

Refer to *Register Access Protection* and *PAC - Peripheral Access Controller*.

#### Related Links

[27. PAC - Peripheral Access Controller](#)

31.4.8 Register Access Protection

# SAM D5x/E5x Family Data Sheet

## EVSYS – Event System

### 31.7.1 Control A

**Name:** CTRLA  
**Offset:** 0x00  
**Reset:** 0x00  
**Property:** PAC Write-Protection

Bit	7	6	5	4	3	2	1	0
								SWRST
Access								W
Reset								0

#### **Bit 0 – SWRST** Software Reset

Writing '0' to this bit has no effect.

Writing '1' to this bit resets all registers in the EVSYS to their initial state. It will always take precedence, meaning that all other writes in the same write-operation will be discarded.

**Note:** Before applying a Software Reset it is recommended to disable the event generators.



# SAM D5x/E5x Family Data Sheet

## EVSYS – Event System

### 31.7.2 Software Event

**Name:** SWEVT  
**Offset:** 0x04  
**Reset:** 0x00000000  
**Property:** PAC Write-Protection

Bit	31	30	29	28	27	26	25	24
	CHANNEL31	CHANNEL30	CHANNEL29	CHANNEL28	CHANNEL27	CHANNEL26	CHANNEL25	CHANNEL24
Access	W	W	W	W	W	W	W	W
Reset	0	0	0	0	0	0	0	0
Bit	23	22	21	20	19	18	17	16
	CHANNEL23	CHANNEL22	CHANNEL21	CHANNEL20	CHANNEL19	CHANNEL18	CHANNEL17	CHANNEL16
Access	W	W	W	W	W	W	W	W
Reset	0	0	0	0	0	0	0	0
Bit	15	14	13	12	11	10	9	8
	CHANNEL15	CHANNEL14	CHANNEL13	CHANNEL12	CHANNEL11	CHANNEL10	CHANNEL9	CHANNEL8
Access	W	W	W	W	W	W	W	W
Reset	0	0	0	0	0	0	0	0
Bit	7	6	5	4	3	2	1	0
	CHANNEL7	CHANNEL6	CHANNEL5	CHANNEL4	CHANNEL3	CHANNEL2	CHANNEL1	CHANNEL0
Access	W	W	W	W	W	W	W	W
Reset	0	0	0	0	0	0	0	0

**Bits 0, 1, 2, 3, 4, 5, 6, 7, 8, 9, 10, 11, 12, 13, 14, 15, 16, 17, 18, 19, 20, 21, 22, 23, 24, 25, 26, 27, 28, 29, 30, 31 – CHANNELx** Channel x Software Selection [x=0..7]

Writing a '0' to this bit has no effect.

Writing a '1' to this bit will trigger a software event for channel x.

These bits always return '0' when read.

### 31.7.3 Priority Control

**Name:** PRICTRL  
**Offset:** 0x08  
**Reset:** 0x00  
**Property:** PAC Write-Protection

	7	6	5	4	3	2	1	0
	RREN				PRI[4:0]			
Access	RW			RW	RW	RW	RW	RW
Reset	0			0	0	0	0	0

#### Bit 7 – RREN Round-Robin Scheduling Enable

For details on scheduling schemes, refer to [Interrupt Status and Interrupts Arbitration](#)

Value	Description
0	Static scheduling scheme for channels with level priority
1	Round-robin scheduling scheme for channels with level priority

#### Bits 4:0 – PRI[4:0] Channel Priority Number

When round-robin arbitration is enabled (PRICTRL.RREN=1) for priority level, this register holds the channel number of the last EVSYS channel being granted access as the active channel with priority level. The value of this bit group is updated each time the INTPEND or any of CHINTFLAG registers are written.

When static arbitration is enabled (PRICTRL.RREN=0) for priority level, and the value of this bit group is nonzero, it will not affect the static priority scheme.

This bit group is not reset when round-robin scheduling gets disabled (PRICTRL.RREN written to zero).

### 31.7.4 Channel Pending Interrupt

**Name:** INTPEND  
**Offset:** 0x10  
**Reset:** 0x4000

An interrupt that handles several channels should consult the INTPEND register to find out which channel number has priority (ignoring/filtering each channel that has its own interrupt line). An interrupt dedicated to only one channel must not use the INTPEND register.

Bit	15	14	13	12	11	10	9	8
	BUSY	READY					EVD	OVR
Access	R	R					RW	RW
Reset	0	1					0	0

Bit	7	6	5	4	3	2	1	0
				ID[4:0]				
Access				RW	RW	RW	RW	RW
Reset				0	0	0	0	0

**Bit 15 – BUSY** Busy

This bit is read '1' when the event on a channel selected by Channel ID field (ID) has not been handled by all the event users connected to this channel.

**Bit 14 – READY** Ready

This bit is read '1' when all event users connected to the channel selected by Channel ID field (ID) are ready to handle incoming events on this channel.

**Bit 9 – EVD** Channel Event Detected

This flag is set on the next CLK\_EVSYS\_APB cycle when an event is being propagated through the channel, and an interrupt request will be generated if CHINTENCLR/SET.EVD is '1'.

When the event channel path is asynchronous, the EVD bit will not be set.

Writing a '0' to this bit has no effect.

Writing a '1' to this bit will clear it. It will also clear the corresponding flag in the Channel n Interrupt Flag Status and Clear register (CHINTFLAGn) of this peripheral, where n is determined by the Channel ID bit field (ID) in this register.

**Bit 8 – OVR** Channel Overrun

This flag is set on the next CLK\_EVSYS cycle after an overrun channel condition occurs, and an interrupt request will be generated if CHINTENCLR/SET.OVRx is '1'.

There are two possible overrun channel conditions:

- One or more of the event users on channel selected by Channel ID field (ID) are not ready when a new event occurs
- An event happens when the previous event on channel selected by Channel ID field (ID) has not yet been handled by all event users

When the event channel path is asynchronous, the OVR interrupt flag will not be set.

Writing a '0' to this bit has no effect.

# SAM D5x/E5x Family Data Sheet

## EVSYS – Event System

---

Writing a '1' to this bit will clear it. It will also clear the corresponding flag in the Channel n Interrupt Flag Status and Clear register (CHINTFLAGn) of this peripheral, where n is determined by the Channel ID bit field (ID) in this register.

**Bits 4:0 – ID[4:0] Channel ID**

These bits store the channel number of the highest priority.

When the bits are written, indirect access to the corresponding Channel Interrupt Flag register is enabled.

# SAM D5x/E5x Family Data Sheet

## EVSYS – Event System

### 31.7.5 Interrupt Status

**Name:** INTSTATUS  
**Offset:** 0x14  
**Reset:** 0x00000000

Bit	31	30	29	28	27	26	25	24									
	<table style="width: 100%; height: 15px; border-collapse: collapse;"> <tr> <td style="width: 12.5%; border: 1px solid black;"></td> <td style="width: 12.5%; border: 1px solid black;"></td> <td style="width: 12.5%; border: 1px solid black;"></td> <td style="width: 12.5%; border: 1px solid black;"></td> <td style="width: 12.5%; border: 1px solid black;"></td> <td style="width: 12.5%; border: 1px solid black;"></td> <td style="width: 12.5%; border: 1px solid black;"></td> <td style="width: 12.5%; border: 1px solid black;"></td> <td style="width: 12.5%; border: 1px solid black;"></td> </tr> </table>																
Access																	
Reset																	
Bit	23	22	21	20	19	18	17	16									
	<table style="width: 100%; height: 15px; border-collapse: collapse;"> <tr> <td style="width: 12.5%; border: 1px solid black;"></td> <td style="width: 12.5%; border: 1px solid black;"></td> <td style="width: 12.5%; border: 1px solid black;"></td> <td style="width: 12.5%; border: 1px solid black;"></td> <td style="width: 12.5%; border: 1px solid black;"></td> <td style="width: 12.5%; border: 1px solid black;"></td> <td style="width: 12.5%; border: 1px solid black;"></td> <td style="width: 12.5%; border: 1px solid black;"></td> <td style="width: 12.5%; border: 1px solid black;"></td> </tr> </table>																
Access																	
Reset																	
Bit	15	14	13	12	11	10	9	8									
	<table style="width: 100%; height: 15px; border-collapse: collapse;"> <tr> <td style="width: 12.5%; border: 1px solid black;"></td> <td style="width: 12.5%; border: 1px solid black;"></td> <td style="width: 12.5%; border: 1px solid black;"></td> <td style="width: 12.5%; border: 1px solid black;"></td> </tr> </table>								CHINT11	CHINT10	CHINT9	CHINT8					
Access					R	R	R	R									
Reset					0	0	0	0									
Bit	7	6	5	4	3	2	1	0									
	CHINT7	CHINT6	CHINT5	CHINT4	CHINT3	CHINT2	CHINT1	CHINT0									
Access	R	R	R	R	R	R	R	R									
Reset	0	0	0	0	0	0	0	0									

**Bits 0, 1, 2, 3, 4, 5, 6, 7, 8, 9, 10, 11 – CHINT Channel x Pending Interrupt**

This bit is set when Channel x has a pending interrupt.

This bit is cleared when the corresponding Channel x interrupts are disabled, or the source interrupt sources are cleared.

# SAM D5x/E5x Family Data Sheet

## EVSYS – Event System

### 31.7.6 Busy Channels

**Name:** BUSYCH  
**Offset:** 0x18  
**Reset:** 0x00000000

Bit	31	30	29	28	27	26	25	24
Access								
Reset								
Bit	23	22	21	20	19	18	17	16
Access								
Reset								
Bit	15	14	13	12	11	10	9	8
					BUSYCHx11	BUSYCHx10	BUSYCHx9	BUSYCHx8
Access					R	R	R	R
Reset					0	0	0	0
Bit	7	6	5	4	3	2	1	0
	BUSYCHx7	BUSYCHx6	BUSYCHx5	BUSYCHx4	BUSYCHx3	BUSYCHx2	BUSYCHx1	BUSYCHx0
Access	R	R	R	R	R	R	R	R
Reset	0	0	0	0	0	0	0	0

**Bits 0, 1, 2, 3, 4, 5, 6, 7, 8, 9, 10, 11 – BUSYCHx** Busy Channel x

This bit is set if an event occurs on channel x has not been handled by all event users connected to channel x.

This bit is cleared when channel x is idle.

When the event channel x path is asynchronous, this bit is always read '0'.

# SAM D5x/E5x Family Data Sheet

## EVSYS – Event System

### 31.7.7 Ready Users

**Name:**      READYUSR  
**Offset:**     0x1C  
**Reset:**      111111111111

	Bit	31	30	29	28	27	26	25	24	
Access		R	R	R	R	R	R	R	R	
Reset		1	1	1	1	1	1	1	1	
	Bit	23	22	21	20	19	18	17	16	
Access		R	R	R	R	R	R	R	R	
Reset		1	1	1	1	1	1	1	1	
	Bit	15	14	13	12	11	10	9	8	
						READYUSR11	READYUSR10	READYUSR9	READYUSR8	
Access		R	R	R	R	R	R	R	R	
Reset		1	1	1	1	1	1	1	1	
	Bit	7	6	5	4	3	2	1	0	
		READYUSR7	READYUSR6	READYUSR5	READYUSR4	READYUSR3	READYUSR2	READYUSR1	READYUSR0	
Access		R	R	R	R	R	R	R	R	
Reset		1	1	1	1	1	1	1	1	

**Bits 0, 1, 2, 3, 4, 5, 6, 7, 8, 9, 10, 11 – READYUSR** Ready User for Channel n  
 This bit is set when all event users connected to channel n are ready to handle incoming events on channel n.  
 This bit is cleared when at least one of the event users connected to the channel is not ready.  
 When the event channel n path is asynchronous, this bit is always read zero.

### 31.7.8 Channel n Control

**Name:** CHANNEL  
**Offset:** 0x20 + n\*0x08 [n=0..31]  
**Reset:** 0x00008000  
**Property:** PAC Write-Protection

This register allows the user to configure channel n. To write to this register, do a single, 32-bit write of all the configuration data.

Bit	31	30	29	28	27	26	25	24
Access								
Reset								
Bit	23	22	21	20	19	18	17	16
Access								
Reset								
Bit	15	14	13	12	11	10	9	8
ONDEMAND	RUNSTDBY				EDGSEL[1:0]		PATH[1:0]	
Access	RW	RW			RW	RW	RW	RW
Reset	1	0			0	0	0	0
Bit	7	6	5	4	3	2	1	0
EVGEN[7:0]								
Access	RW	RW	RW	RW	RW	RW	RW	RW
Reset	0	0	0	0	0	0	0	0

#### Bit 15 – ONDEMAND Generic Clock On Demand

Value	Description
0	Generic clock for a channel is always on, if the channel is configured and generic clock source is enabled.
1	Generic clock is requested on demand while an event is handled

#### Bit 14 – RUNSTDBY Run in Standby

This bit is used to define the behavior during standby sleep mode.

Value	Description
0	The channel is disabled in standby sleep mode.
1	The channel is not stopped in standby sleep mode and depends on the CHANNEL.ONDEMAND bit.

#### Bits 11:10 – EDGSEL[1:0] Edge Detection Selection

These bits set the type of edge detection to be used on the channel.

These bits must be written to zero when using the asynchronous path.

Value	Name	Description
0x0	NO_EVT_OUTPUT	No event output when using the resynchronized or synchronous path
0x1	RISING_EDGE	Event detection only on the rising edge of the signal from the event generator



# SAM D5x/E5x Family Data Sheet

## EVSYS – Event System

Value	Name	Description
0x2	FALLING_EDGE	Event detection only on the falling edge of the signal from the event generator
0x3	BOTH_EDGES	Event detection on rising and falling edges of the signal from the event generator

### Bits 9:8 – PATH[1:0] Path Selection

These bits are used to choose which path will be used by the selected channel.

**Note:** The path choice can be limited by the channel source, see the table in [31.7.13 USERm](#).



**Important:** Only EVSYS channel 0 to 11 can be configured as synchronous or resynchronized.

Value	Name	Description
0x0	SYNCHRONOUS	Synchronous path
0x1	RESYNCHRONIZED	Resynchronized path
0x2	ASYNCHRONOUS	Asynchronous path
Other	-	Reserved

### Bits 7:0 – EVGEN[7:0] Event Generator Selection

These bits are used to choose the event generator to connect to the selected channel.

Value	Name	Description
0x00	NONE	No event generator selected
0x01 - 0x02	OSCCTRL_XOSC_FAILx	XOSC fail detection x=0..1
0x03	OSC32KCTRL_XOSC32K_FAIL	XOSC32K fail detection
0x04 - 0x0B	RTC_PERx	RTC period x=0..7
0x0C - 0x0F	RTC_CMP	RTC comparison x=0..3
0x10	RTC_TAMPER	RTC tamper detection
0x11	RTC_OVF	RTC overflow
0x12 - 0x21	EIC_EXTINT	EIC external interrupt x=0..15
0x22 - 0x25	DMAC_CH	DMA channel x=0..3
0x26	PAC_ACCERR	PAC Acc. error
0x27	Reserved	-
0x28	Reserved	-
0x29	TCC0_OVF	TCC0 Overflow
0x2A	TCC0_TRG	TCC0 Trigger Event
0x2B	TCC0_CNT	TCC0 Counter
0x2C - 0x31	TCC0_MCx	TCC0 Match/Compare x=0..5
0x32	TCC1_OVF	TCC1 Overflow

# SAM D5x/E5x Family Data Sheet

## EVSYS – Event System

.....continued		
Value	Name	Description
0x33	TCC1_TRG	TCC1 Trigger Event
0x34	TCC1_CNT	TCC1 Counter
0x35 - 0x38	TCC1_MCx	TCC1 Match/Compare x=0..3
0x39	TCC2_OVF	TCC2 Overflow
0x3A	TCC2_TRG	TCC2 Trigger Event
0x3B	TCC2_CNT	TCC2 Counter
0x3C - 0x3E	TCC2_MCx	TCC2 Match/Compare x=0..2
0x3F	TCC3_OVF	TCC3 Overflow
0x40	TCC3_TRG	TCC3 Trigger Event
0x41	TCC3_CNT	TCC3 Counter
0x42 - 0x43	TCC3_MCx	TCC3 Match/Compare x=0..1
0x44	TCC4_OVF	TCC4 Overflow
0x45	TCC4_TRG	TCC4 Trigger Event
0x46	TCC4_CNT	TCC4 Counter
0x47 - 0x48	TCC4_MCx	TCC4 Match/Compare x=0..1
0x49	TC0_OVF	TC0 Overflow
0x4A - 0x4B	TC0_MCx	TC0 Match/Compare x=0..1
0x4C	TC1_OVF	TC1 Overflow
0x4D - 0x4E	TC1_MCx	TC1 Match/Compare x=0..1
0x4F	TC2_OVF	TC2 Overflow
0x50 - 0x51	TC2_MCx	TC2 Match/Compare x=0..1
0x52	TC3_OVF	TC3 Overflow
0x53 - 0x54	TC3_MCx	TC3 Match/Compare x=0..1
0x55	TC4_OVF	TC4 Overflow
0x56 - 0x57	TC4_MCx	TC4 Match/Compare x=0..1
0x58	TC5_OVF	TC5 Overflow
0x59 - 0x5A	TC5_MCx	TC5 Match/Compare x=0..1
0x5B	TC6_OVF	TC6 Overflow
0x5C - 0x5D	TC6_MCx	TC6 Match/Compare x=0..1
0x5E	TC7_OVF	TC7 Overflow
0x5F - 0x60	TC7_MCx	TC7 Match/Compare x=0..1

# SAM D5x/E5x Family Data Sheet

## EVSYS – Event System

.....continued

Value	Name	Description
0x61	PDEC_OVF	PDEC Overflow
0x62	PDEC_ERR	PDEC Error
0x63	PDEC_DIR	PDEC Direction
0x64	PDEC_VLC	PDEC VLC
0x65 - 0x66	PDEC_MCx	PDEC MCx x=0..1
0x67	ADC0_RESRDY	ADC0 RESRDY
0x68	ADC0_WINMON	ADC0 Window Monitor
0x69	ADC1_RESRDY	ADC1 RESRDY
0x6A	ADC1_WINMON	ADC1 Window Monitor
0x6B - 0x6C	AC_COMPx	AC Comparator, x=0..1
0x6D	AC_WIN	AC0 Window
0x6E - 0x6F	DAC_EMPTYx	DAC empty, x=0..1
0x70 - 0x71	DAC_RESRDYx	DAC RSRDY, x=0..1
0x72	GMAC_TSU_CMP	GMAC Timestamp CMP
0x73	TRNG_READY	TRNG ready
0x74 - 0x77	CCL_LUTOUT	CCL LUTOUT

### 31.7.9 Channel n Interrupt Enable Clear

**Name:** CHINTENCLR  
**Offset:** 0x24 + n\*0x08 [n=0..31]  
**Reset:** 0x00  
**Property:** PAC Write-Protection

	7	6	5	4	3	2	1	0
							EVD	OVR
Access							RW	RW
Reset							0	0

#### Bit 1 – EVD Channel Event Detected Interrupt Disable

Writing a '0' to this bit has no effect.

Writing a '1' to this bit will clear the Event Detected Channel Interrupt Enable bit, which disables the Event Detected Channel interrupt.

Value	Description
0	The Event Detected Channel interrupt is disabled.
1	The Event Detected Channel interrupt is enabled.

#### Bit 0 – OVR Channel Overrun Interrupt Disable

Writing a '0' to this bit has no effect.

Writing a '1' to this bit will clear the Overrun Channel Interrupt Enable bit, which disables the Overrun Channel interrupt.

Value	Description
0	The Overrun Channel interrupt is disabled.
1	The Overrun Channel interrupt is enabled.

### 31.7.10 Channel n Interrupt Enable Set

**Name:** CHINTENSET  
**Offset:** 0x25 + n\*0x08 [n=0..31]  
**Reset:** 0x00  
**Property:** PAC Write-Protection

	7	6	5	4	3	2	1	0
							EVD	OVR
Access							RW	RW
Reset							0	0

#### Bit 1 – EVD Channel Event Detected Interrupt Enable

Writing a '0' to this bit has no effect.

Writing a '1' to this bit will set the Event Detected Channel Interrupt Enable bit, which enables the Event Detected Channel interrupt.

Value	Description
0	The Event Detected Channel interrupt is disabled.
1	The Event Detected Channel interrupt is enabled.

#### Bit 0 – OVR Channel Overrun Interrupt Enable

Writing a '0' to this bit has no effect.

Writing a '1' to this bit will set the Overrun Channel Interrupt Enable bit, which enables the Overrun Channel interrupt.

Value	Description
0	The Overrun Channel interrupt is disabled.
1	The Overrun Channel interrupt is enabled.

### 31.7.11 Channel n Interrupt Flag Status and Clear

**Name:** CHINTFLAG  
**Offset:** 0x26 + n\*0x08 [n=0..31]  
**Reset:** 0x00

	7	6	5	4	3	2	1	0
							EVD	OVR
Access							RW	RW
Reset							0	0

**Bit 1 – EVD** Channel Event Detected

This flag is set on the next CLK\_EVSYS\_APB cycle when an event is being propagated through the channel, and an interrupt request will be generated if CHINTENCLR/SET.EVD is '1'.

When the event channel path is asynchronous, the EVD interrupt flag will not be set.

Writing a '0' to this bit has no effect.

Writing a '1' to this bit will clear the Event Detected Channel interrupt flag.

**Bit 0 – OVR** Channel Overrun

This flag is set on the next CLK\_EVSYS cycle after an overrun channel condition occurs, and an interrupt request will be generated if CHINTENCLR/SET.OVRx is '1'.

There are two possible overrun channel conditions:

- One or more of the event users on the channel are not ready when a new event occurs.
- An event happens when the previous event on channel has not yet been handled by all event users.

When the event channel path is asynchronous, the OVR interrupt flag will not be set.

Writing a '0' to this bit has no effect.

Writing a '1' to this bit will clear the Overrun Channel interrupt flag.

### 31.7.12 Channel n Status

**Name:** CHSTATUSn  
**Offset:** 0x27 + n\*0x08 [n=0..31]  
**Reset:** 0x01

	7	6	5	4	3	2	1	0
							BUSYCH	RDYUSR
Access							R	R
Reset							0	0

**Bit 1 – BUSYCH** Busy Channel

This bit is cleared when channel is idle.

This bit is set if an event on channel has not been handled by all event users connected to channel.

When the event channel path is asynchronous, this bit is always read '0'.

**Bit 0 – RDYUSR** Ready User

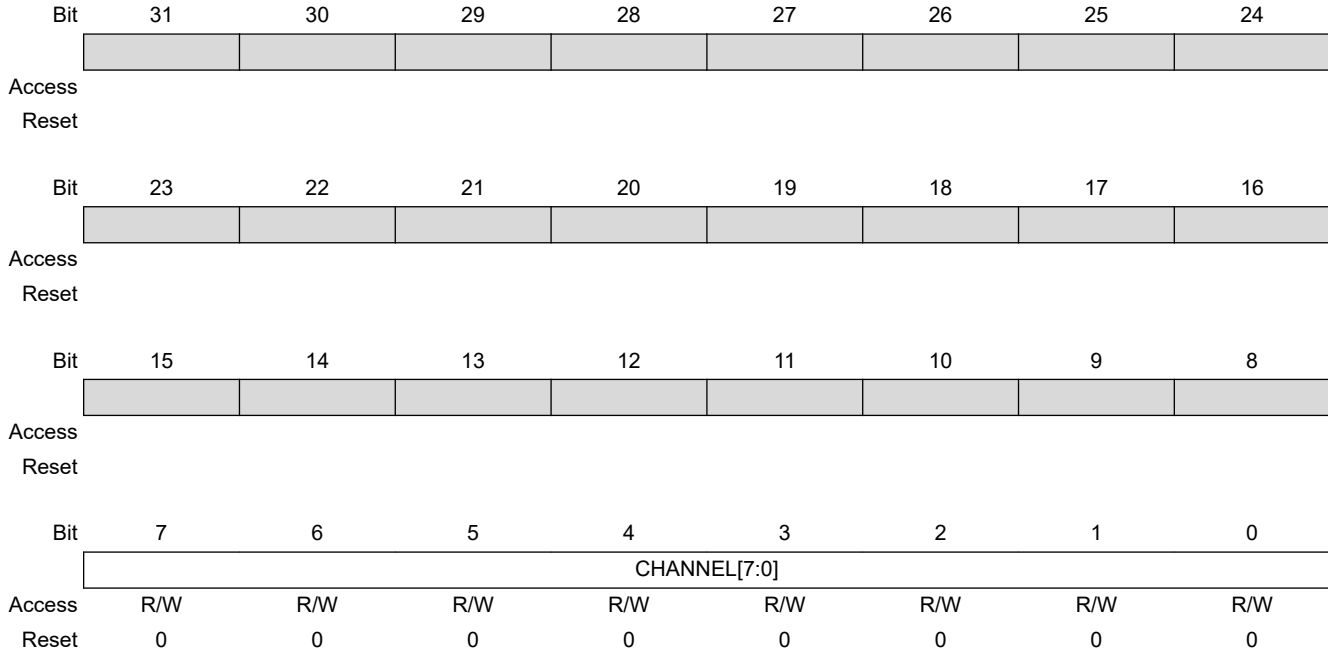
This bit is cleared when at least one of the event users connected to the channel is not ready.

This bit is set when all event users connected to channel are ready to handle incoming events on the channel.

When the event channel path is asynchronous, this bit is always read zero.

### 31.7.13 Event User m

**Name:** USERm  
**Offset:** 0x0120 + m\*0x04 [m=0..66]  
**Reset:** 0x00000000  
**Property:** PAC Write-Protection



#### Bits 7:0 – CHANNEL[7:0] Channel Event Selection

These bits select channel n to connect to the event user m. The following table lists all of the Event Users and the associated 'm' value to determine which USERm register to define the desired Event Channel.

**Note:** A value x of this bit field selects channel n = x-1.

**Table 31-2. User Multiplexer Number m**

USERm	User Multiplexer	Description	Path Type <sup>(1)</sup>
m = 0	RTC_TAMPER	RTC Tamper	A
m = 1..4	PORT_EV0..3	PORT Event 0..3	A
m = 5..12	DMAC_CH0..7	Channel 0..7	S, R
m = 13	-	Reserved	-
m = 14	CM4_TRACE_START	CM4 trace start	S, R
m = 15	CM4_TRACE_STOP	CM4 trace stop	S, R
m = 16	CM4_TRACE_TRIG	CM4 trace trigger	S, R
m = 17..18	TCC0_EV0..1	TCC0 EVx	A, S, R
m = 19..24	TCC0_MC0..5	TCC0 MCx	A, S, R



# SAM D5x/E5x Family Data Sheet

## EVSYS – Event System

.....continued			
USER $m$	User Multiplexer	Description	Path Type <sup>(1)</sup>
m = 25..26	TCC1 EV0..1	TCC1 EVx	A, S, R
m = 27..30	TCC1 MC0..3	TCC1 MCx	A, S, R
m = 31..32	TCC2 EV0..1	TCC2 EVx	A, S, R
m = 33..35	TCC2 MC0..2	TCC2 MCx	A, S, R
m = 36..37	TCC3 EV0..1	TCC3 EVx	A, S, R
m = 38..39	TCC3 MC0..1	TCC3 MCx	A, S, R
m = 40..41	TCC4 EV0..1	TCC4 EVx	A, S, R
m = 42..43	TCC4 MC0..1	TCC4 MCx	A, S, R
m = 44..51	TC0..7 EVU	TC0..7 EVU	A, S, R
m = 52..54	PDEC_EVU 0..2	PDEC EVU x	A, S, R
m = 55	ADC0 START	ADC0 start conversion	A, S, R
m = 56	ADC0 SYNC	Flush ADC0	A, S, R
m = 57	ADC1 START	ADC1 start conversion	A, S, R
m = 58	ADC1 SYNC	Flush ADC1	A, S, R
m = 59..60	AC_SOC 0..1	AC SOC x	A
m = 61..62	DAC_START0..1	DAC0..1 start conversion	A
m = 63..66	CCL_LUTIN 0..3	CCL input	A
others	Reserved	-	-

**Note:**

1. A = Asynchronous path, S = Synchronous path, R = Resynchronized path

Value	Description
0x00	No channel selected
0x01	Channel 0 selected
0x02	Channel 1 selected
0x03	Channel 2 selected
0x04	Channel 3 selected
0x05	Channel 4 selected
0x06	Channel 5 selected
0x07	Channel 6 selected
0x08	Channel 7 selected
0x09	Channel 8 selected
0x0A	Channel 9 selected
0x0B	Channel 10 selected
0x0C	Channel 11 selected
0x0D	Channel 12 selected
0x0E	Channel 13 selected

# SAM D5x/E5x Family Data Sheet

## EVSYS – Event System

Value	Description
0x0F	Channel 14 selected
0x10	Channel 15 selected
0x11	Channel 16 selected
0x12	Channel 17 selected
0x13	Channel 18 selected
0x14	Channel 19 selected
0x15	Channel 20 selected
0x16	Channel 21 selected
0x17	Channel 22 selected
0x18	Channel 23 selected
0x19	Channel 24 selected
0x1A	Channel 25 selected
0x1B	Channel 26 selected
0x1C	Channel 27 selected
0x1D	Channel 28 selected
0x1E	Channel 29 selected
0x1F	Channel 30 selected
0x20	Channel 31 selected
other	Reserved

## **32. PORT - I/O Pin Controller**

### **32.1 Overview**

The I/O Pin Controller (PORT) controls the I/O pins of the device. The I/O pins are organized in a series of groups, collectively referred to as a PORT group. Each PORT group can have up to 32 pins that can be configured and controlled individually or as a group. The number of PORT groups on a device may depend on the package or number of pins. Each pin may either be used for general purpose I/O under direct application control or be assigned to an embedded device peripheral. When used for general purpose I/O, each pin can be configured as input or output, with a highly configurable driver and pull settings.

All I/O pins have true read-modify-write functionality when used for general purpose I/O. The direction or the output value of one or more pins may be changed (set, Reset or toggled) explicitly without unintentionally changing the state of any other pins in the same port group by a single, atomic 8-, 16- or 32-bit write.

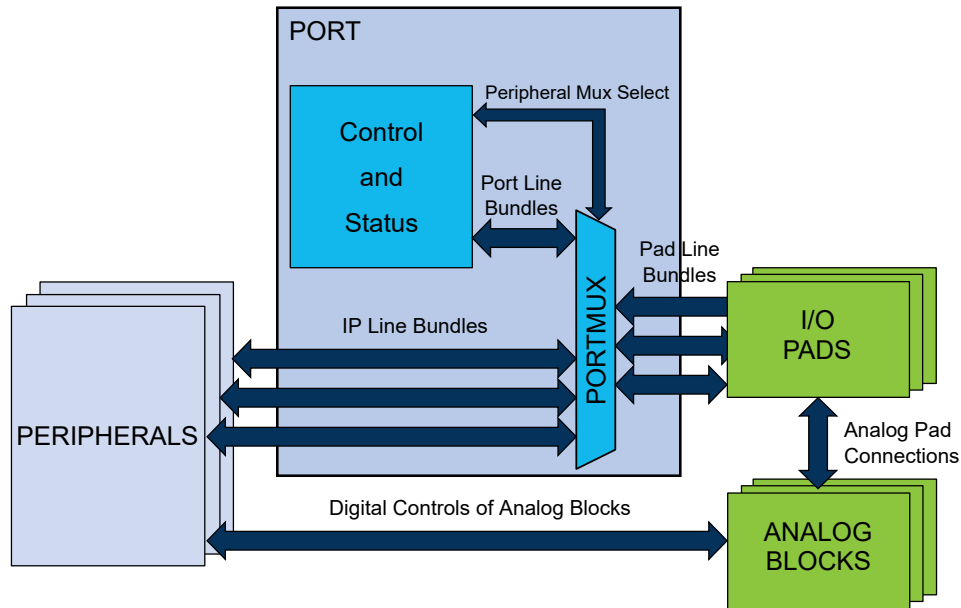
The PORT is connected to the high-speed bus matrix through an AHB/APB bridge.

### **32.2 Features**

- Selectable Input and Output Configuration for Each Individual Pin
- Software-controlled Multiplexing of Peripheral Functions on I/O Pins
- Flexible Pin Configuration Through a Dedicated Pin Configuration Register
- Configurable Output Driver and Pull Settings:
  - Totem-pole (push-pull)
  - Pull configuration
  - Driver strength
- Configurable Input Buffer and Pull Settings:
  - Internal pull-up or pull-down
  - Input sampling criteria
  - Input buffer can be disabled if not needed for lower power consumption
  - Read-Modify-Write support for output value (OUTCLR/OUTSET/OUTGL) and pin direction (DIRCLR/DIRSET/DIRTGL)
- Input Event:
  - Up to four input event pins for each PORT group
  - SET/CLEAR/TOGGLE event actions for each event input on output value of a pin
  - Can be output to pin

### 32.3 Block Diagram

Figure 32-1. PORT Block Diagram



### 32.4 Signal Description

Table 32-1. Signal Description for PORT

Signal name	Type	Description
Pxy	Digital I/O	General purpose I/O pin y in group x

Refer to the *I/O Multiplexing and Considerations* for details on the pin mapping for this peripheral. One signal can be mapped on several pins.

#### Related Links

[6. I/O Multiplexing and Considerations](#)

### 32.5 Product Dependencies

In order to use this peripheral, other parts of the system must be configured correctly as follows.

#### 32.5.1 I/O Lines

The I/O lines of the PORT are mapped to pins of the physical device. The following naming scheme is used:

Each line bundle with up to 32 lines is assigned an identifier 'xy', with letter x=A, B, C... and two-digit number y=00, 01, ...31. Examples: A24, C03.

PORT pins are labeled 'Pxy' accordingly, for example PA24, PC03. This identifies each pin in the device uniquely.

Each pin may be controlled by one or more peripheral multiplexer settings, which allows the pad to be routed internally to a dedicated peripheral function. When the setting is enabled, the selected peripheral

has control over the Output state of the pad, as well as the ability to read the current Physical Pad state. Refer to *I/O Multiplexing and Considerations* for details.

Device-specific configurations may cause some lines (and the corresponding Pxy pin) not to be implemented.

### Related Links

[6. I/O Multiplexing and Considerations](#)

### 32.5.2 Power Management

During Reset, all PORT lines are configured as inputs with input buffers, output buffers and pull disabled.

When the device is set to the BACKUP sleep mode, even if the PORT configuration registers and input synchronizers will lose their contents (these will not be restored when PORT is powered up again), the latches in the pads will keep their current configuration, such as the output value and pull settings. Refer to the Power Manager documentation for more features related to the I/O lines configuration in and out of BACKUP mode.

The PORT peripheral will continue operating in any Sleep mode where its source clock is running.

### Related Links

[18.6.3.4 I/O Lines Retention in HIBERNATE or BACKUP Mode](#)

### 32.5.3 Clocks

The PORT bus clock (CLK\_PORT\_APB) can be enabled and disabled in the Main Clock module, and the default state of CLK\_PORT\_APB can be found in the *Peripheral Clock Masking* section in *MCLK – Main Clock*.

The PORT requires an APB clock, which may be divided from the CPU main clock and allows the CPU to access the registers of PORT through the high-speed matrix and the AHB/APB bridge.

One clock cycle latency can be observed on the APB access in case of concurrent PORT accesses.

### Related Links

[15. MCLK – Main Clock](#)

### 32.5.4 DMA

Not applicable.

### 32.5.5 Interrupts

Not applicable.

### 32.5.6 Events

The events of this peripheral are connected to the Event System.

The output of an event to a pin through PORT is always asynchronous. This must be configured in the Event System by writing ASYNCHRONOUS to the Path Selection bits in the respective Channel n Control register of the Event System (EVSYS.CHANNELn.PATH).

### Related Links

[31. EVSYS – Event System](#)

### 32.5.7 Debug Operation

When the CPU is halted in Debug mode, this peripheral will continue normal operation.

### 32.5.8 Register Access Protection

All registers with write access can be optionally write-protected by the Peripheral Access Controller (PAC).

**Note:** Optional write protection is indicated by the "PAC Write Protection" property in the register description.

Write protection does not apply for accesses through an external debugger.

#### Related Links

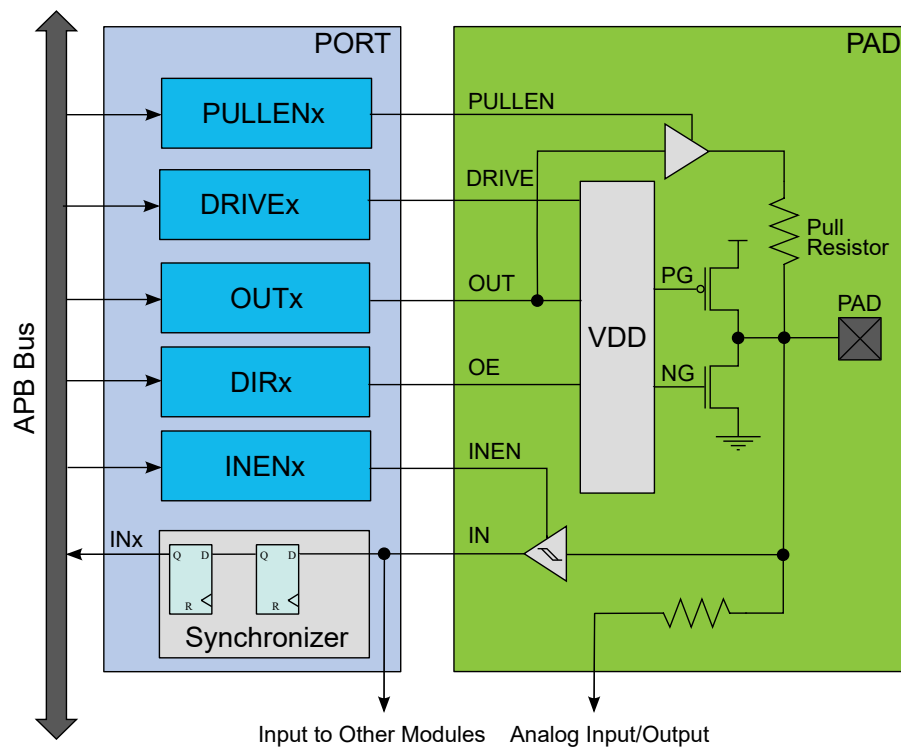
[27. PAC - Peripheral Access Controller](#)

### 32.5.9 Analog Connections

Analog functions are connected directly between the analog blocks and the I/O pads using analog buses. However, selecting an analog peripheral function for a given pin will disable the corresponding digital features of the pad.

## 32.6 Functional Description

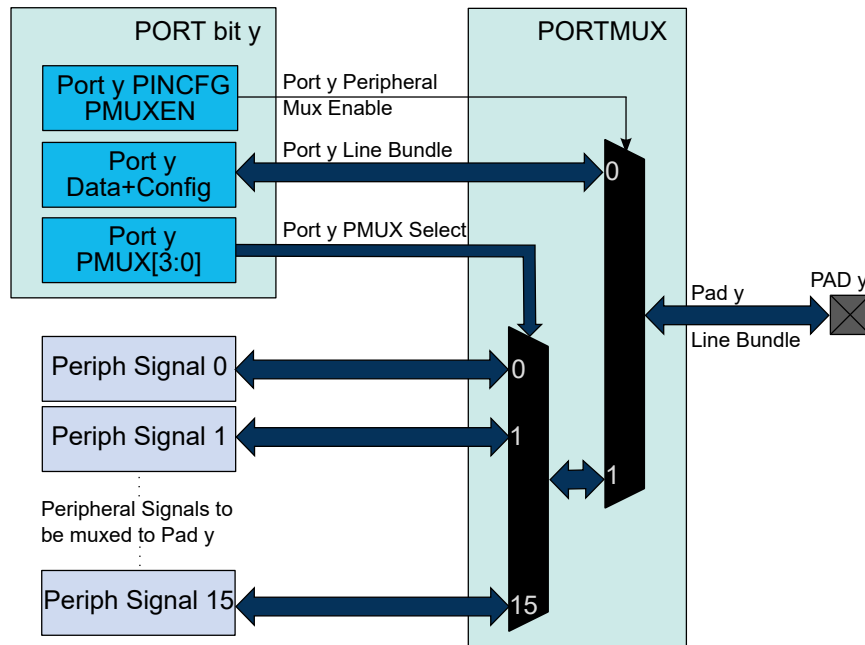
Figure 32-2. Overview of the PORT



### 32.6.1 Principle of Operation

Each PORT group of up to 32 pins is controlled by the registers in PORT, as described in the figure. These registers in PORT are duplicated for each PORT group, with increasing base addresses. The number of PORT groups may depend on the package/number of pins.

**Figure 32-3. Overview of the peripheral functions multiplexing**



The I/O pins of the device are controlled by PORT peripheral registers. Each port pin has a corresponding bit in the Data Direction (DIR) and Data Output Value (OUT) registers to enable that pin as an output and to define the Output state.

The direction of each pin in a PORT group is configured by the DIR register. If a bit in DIR is set to '1', the corresponding pin is configured as an output pin. If a bit in DIR is set to '0', the corresponding pin is configured as an input pin.

When the direction is set as output, the corresponding bit in the OUT register will set the level of the pin. If bit  $y$  in OUT is written to '1', pin  $y$  is driven HIGH. If bit  $y$  in OUT is written to '0', pin  $y$  is driven LOW. Pin configuration can be set by Pin Configuration (PINCFG $y$ ) registers, with  $y=00, 01, \dots, 31$  representing the bit position.

The Data Input Value (IN) is set as the input value of a port pin with resynchronization to the PORT clock. To reduce power consumption, these input synchronizers can be clocked only when system requires reading the input value, as specified in the SAMPLING field of the Control register (CTRL). The value of the pin can always be read, whether the pin is configured as input or output. If the Input Enable bit in the Pin Configuration registers (PINCFG $y$ .INEN) is '0', the input value will not be sampled.

In PORT, the Peripheral Multiplexer Enable bit in the PINCFG $y$  register (PINCFG $y$ .PMUXEN) can be written to '1' to enable the connection between peripheral functions and individual I/O pins. The Peripheral Multiplexing  $n$  (PMUX $n$ ) registers select the peripheral function for the corresponding pin. This will override the connection between the PORT and that I/O pin, and connect the selected peripheral signal to the particular I/O pin instead of the PORT line bundle.

### 32.6.2 Basic Operation

#### 32.6.2.1 Initialization

After reset, all standard function device I/O pads are connected to the PORT with outputs tri-stated and input buffers disabled, even if there is no clock running.

However, specific pins, such as those used for connection to a debugger, may be configured differently, as required by their special function.

### 32.6.2.2 Operation

Each I/O pin Pxy can be controlled by the registers in PORT. Each PORT group x has its own set of PORT registers, with a base address at byte address (PORT + 0x80 \* group index) (A corresponds to group index 0, B to 1, etc...). Within that set of registers, the pin index is y, from 0 to 31.

Refer to *I/O Multiplexing and Considerations* for details on available pin configuration and PORT groups.

#### Configuring Pins as Output

To use pin Pxy as an *output*, write bit y of the DIR register to '1'. This can also be done by writing bit y in the DIRSET register to '1' - this will avoid disturbing the configuration of other pins in that group. The y bit in the OUT register must be written to the desired output value.

Similarly, writing an OUTSET bit to '1' will set the corresponding bit in the OUT register to '1'. Writing a bit in OUTCLR to '1' will set that bit in OUT to zero. Writing a bit in OUTTGL to '1' will toggle that bit in OUT.

#### Configuring Pins as Input

To use pin Pxy as an *input*, bit y in the DIR register must be written to '0'. This can also be done by writing bit y in the DIRCLR register to '1' - this will avoid disturbing the configuration of other pins in that group. The input value can be read from bit y in register IN as soon as the INEN bit in the Pin Configuration register (PINCFGy.INEN) is written to '1'.

By default, the input synchronizer is clocked only when an input read is requested. This will delay the read operation by two cycles of the PORT clock. To remove the delay, the input synchronizers for each PORT group of eight pins can be configured to be always active, but this will increase power consumption. This is enabled by writing '1' to the corresponding SAMPLINGn bit field of the CTRL register, see CTRL.SAMPLING for details.

#### Using Alternative Peripheral Functions

To use pin Pxy as one of the available peripheral functions, the corresponding PMUXEN bit of the PINCFGy register must be '1'. The PINCFGy register for pin Pxy is at byte offset (PINCFG0 + y).

The peripheral function can be selected by setting the PMUXO or PMUXE in the PMUXn register. The PMUXO/PMUXE is at byte offset PMUX0 + (y/2). The chosen peripheral must also be configured and enabled.

#### Related Links

[6. I/O Multiplexing and Considerations](#)

### 32.6.3 I/O Pin Configuration

The Pin Configuration register (PINCFGy) is used for additional I/O pin configuration. A pin can be set in a totem-pole or pull configuration.

As pull configuration is done through the Pin Configuration register, all intermediate PORT states during switching of pin direction and pin values are avoided.

The I/O pin configurations are described further in this chapter, and summarized in [Table 32-2](#).

#### 32.6.3.1 Pin Configurations Summary

**Table 32-2. Pin Configurations Summary**

DIR	INEN	PULLEN	OUT	Configuration
0	0	0	X	Reset or analog I/O: all digital disabled

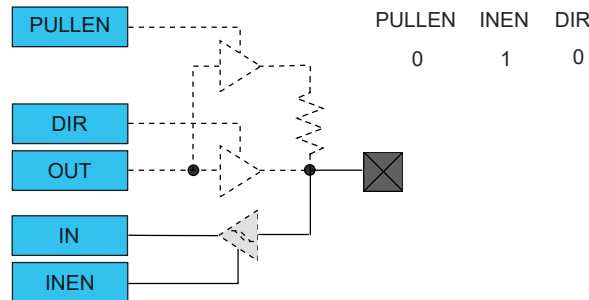


.....continued

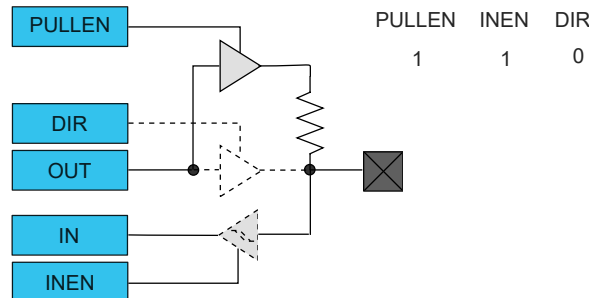
DIR	INEN	PULLEN	OUT	Configuration
0	0	1	0	Pull-down; input disabled
0	0	1	1	Pull-up; input disabled
0	1	0	X	Input
0	1	1	0	Input with pull-down
0	1	1	1	Input with pull-up
1	0	X	X	Output; input disabled
1	1	X	X	Output; input enabled

### 32.6.3.2 Input Configuration

**Figure 32-4. I/O configuration - Standard Input**



**Figure 32-5. I/O Configuration - Input with Pull**



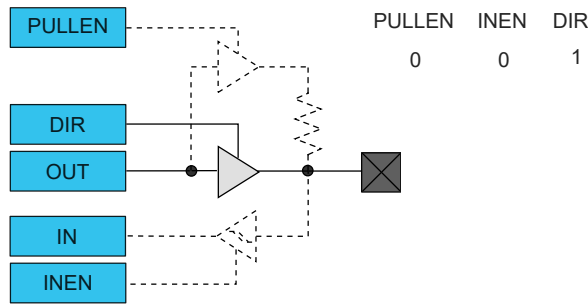
**Note:** When pull is enabled, the pull value is defined by the OUT value.

### 32.6.3.3 Totem-Pole Output

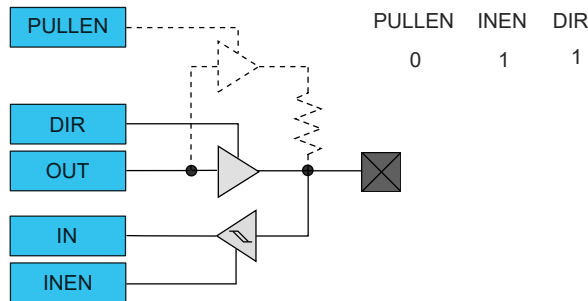
When configured for totem-pole (push-pull) output, the pin is driven low or high according to the corresponding bit setting in the OUT register. In this configuration there is no current limitation for sink or source other than what the pin is capable of. If the pin is configured for input, the pin will float if no external pull is connected.

**Note:** Enabling the output driver will automatically disable pull.

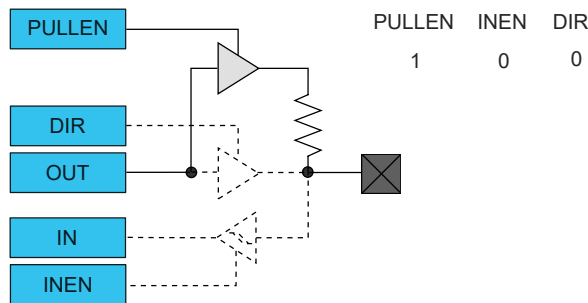
**Figure 32-6. I/O Configuration - Totem-Pole Output with Disabled Input**



**Figure 32-7. I/O Configuration - Totem-Pole Output with Enabled Input**



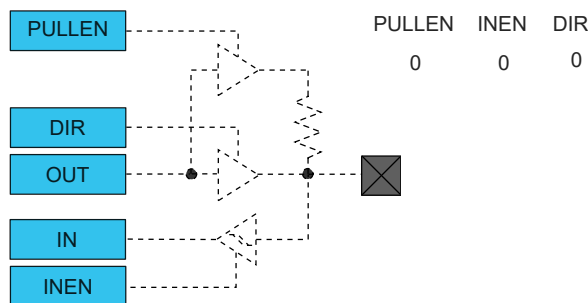
**Figure 32-8. I/O Configuration - Output with Pull**



### 32.6.3.4 Digital Functionality Disabled

Neither Input nor Output functionality are enabled.

**Figure 32-9. I/O Configuration - Reset or Analog I/O: Digital Output, Input and Pull Disabled**



### 32.6.4 Events

The PORT allows input events to control individual I/O pins. These input events are generated by the EVSYS module and can originate from a different clock domain than the PORT module.

The PORT can perform the following actions:

- Output (OUT): I/O pin will be set when the incoming event has a high level ('1') and cleared when the incoming event has a low-level ('0').
- Set (SET): I/O pin will be set when an incoming event is detected.
- Clear (CLR): I/O pin will be cleared when an incoming event is detected.
- Toggle (TGL): I/O pin will toggle when an incoming event is detected.

The event is output to pin without any internal latency. For SET, CLEAR and TOGGLE event actions, the action will be executed up to three clock cycles after a rising edge.

The event actions can be configured with the Event Action m bit group in the Event Input Control register( EVCTRL.EVACTm). Writing a '1' to a PORT Event Enable Input m of the Event Control register (EVCTRL.PORTEIm) enables the corresponding action on input event. Writing '0' to this bit disables the corresponding action on input event. Note that several actions can be enabled for incoming events. If several events are connected to the peripheral, any enabled action will be taken for any of the incoming events. Refer to *EVSYS – Event System*. for details on configuring the Event System.

Each event input can address one and only one I/O pin at a time. The selection of the pin is indicated by the PORT Event Pin Identifier of the Event Input Control register (EVCTR.PIDn). On the other hand, one I/O pin can be addressed by up to four different input events. To avoid action conflict on the output value of the register (OUT) of this particular I/O pin, only one action is performed according to the table below.

Note that this truth table can be applied to any SET/CLR/TGL configuration from two to four active input events.

**Table 32-3. Priority on Simultaneous SET/CLR/TGL Event Actions**

EVACT0	EVACT1	EVACT2	EVACT3	Executed Event Action
SET	SET	SET	SET	SET
CLR	CLR	CLR	CLR	CLR
All Other Combinations				TGL

Be careful when the event is output to pin. Due to the fact the events are received asynchronously, the I/O pin may have unpredictable levels, depending on the timing of when the events are received. When several events are output to the same pin, the lowest event line will get the access. All other events will be ignored.

### Related Links

[31. EVSYS – Event System](#)

### 32.6.5 PORT Access Priority

The PORT is accessed by different systems:

- The ARM® CPU through the high-speed matrix and the AHB/APB bridge (APB)
- EVSYS through four asynchronous input events

The following priority is adopted:

1. APB
2. EVSYS input events, except for events with EVCTRL.EVACTn=OUT, where the output pin directly follows the event input signal, independently of the OUT register value.

For input events that require different actions on the same I/O pin, refer to [32.6.4 Events](#).

# SAM D5x/E5x Family Data Sheet

## PORT - I/O Pin Controller

### 32.7 Register Summary

The I/O pins are assembled in pin groups with up to 32 pins. Group 0 consists of the PA pins, and group 1 is for the PB pins, etc. Each pin group has its own PORT registers, with a 0x80 address spacing. For example, the register address offset for the Data Direction (DIR) register for group 0 (PA00 to PA31) is 0x00, and the register address offset for the DIR register for group 1 (PB00 to PB31) is 0x80.

Offset	Name	Bit Pos.							
0x00	DIR	7:0							DIR[7:0]
		15:8							DIR[15:8]
		23:16							DIR[23:16]
		31:24							DIR[31:24]
0x04	DIRCLR	7:0							DIRCLR[7:0]
		15:8							DIRCLR[15:8]
		23:16							DIRCLR[23:16]
		31:24							DIRCLR[31:24]
0x08	DIRSET	7:0							DIRSET[7:0]
		15:8							DIRSET[15:8]
		23:16							DIRSET[23:16]
		31:24							DIRSET[31:24]
0x0C	DIRTGL	7:0							DIRTGL[7:0]
		15:8							DIRTGL[15:8]
		23:16							DIRTGL[23:16]
		31:24							DIRTGL[31:24]
0x10	OUT	7:0							OUT[7:0]
		15:8							OUT[15:8]
		23:16							OUT[23:16]
		31:24							OUT[31:24]
0x14	OUTCLR	7:0							OUTCLR[7:0]
		15:8							OUTCLR[15:8]
		23:16							OUTCLR[23:16]
		31:24							OUTCLR[31:24]
0x18	OUTSET	7:0							OUTSET[7:0]
		15:8							OUTSET[15:8]
		23:16							OUTSET[23:16]
		31:24							OUTSET[31:24]
0x1C	OUTTGL	7:0							OUTTGL[7:0]
		15:8							OUTTGL[15:8]
		23:16							OUTTGL[23:16]
		31:24							OUTTGL[31:24]
0x20	IN	7:0							IN[7:0]
		15:8							IN[15:8]
		23:16							IN[23:16]
		31:24							IN[31:24]

# SAM D5x/E5x Family Data Sheet

## PORT - I/O Pin Controller

.....continued											
Offset	Name	Bit Pos.									
0x24	CTRL	7:0	SAMPLING[7:0]								
		15:8	SAMPLING[15:8]								
		23:16	SAMPLING[23:16]								
		31:24	SAMPLING[31:24]								
0x28	WRCONFIG	7:0	PINMASK[7:0]								
		15:8	PINMASK[15:8]								
		23:16		DRVSTR				PULLEN	INEN	PMUXEN	
		31:24	HWSEL	WRPINCFG		WRPMUX	PMUX[3:0]				
0x2C	EVCTRL	7:0	PORTEIx	EVACTx[1:0]		PIDx[4:0]					
		15:8	PORTEIx	EVACTx[1:0]		PIDx[4:0]					
		23:16	PORTEIx	EVACTx[1:0]		PIDx[4:0]					
		31:24	PORTEIx	EVACTx[1:0]		PIDx[4:0]					
0x30	PMUX0	7:0	PMUXO[3:0]			PMUXE[3:0]					
...											
0x3F	PMUX15	7:0	PMUXO[3:0]			PMUXE[3:0]					
0x40	PINCFG0	7:0		DRVSTR			PULLEN	INEN	PMUXEN		
...											
0x5F	PINCFG31	7:0		DRVSTR			PULLEN	INEN	PMUXEN		

### 32.8 Register Description

Registers can be 8, 16, or 32 bits wide. Atomic 8-, 16- and 32-bit accesses are supported. In addition, the 8-bit quarters and 16-bit halves of a 32-bit register, and the 8-bit halves of a 16-bit register can be accessed directly.

Some registers are optionally write-protected by the Peripheral Access Controller (PAC). Optional PAC write protection is denoted by the "PAC Write-Protection" property in each individual register description. For details, refer to [32.5.8 Register Access Protection](#).

# SAM D5x/E5x Family Data Sheet

## PORT - I/O Pin Controller

### 32.8.1 Data Direction

**Name:** DIR  
**Offset:** 0x00  
**Reset:** 0x00000000  
**Property:** PAC Write-Protection

This register allows the user to configure one or more I/O pins as an input or output. This register can be manipulated without doing a read-modify-write operation by using the Data Direction Toggle (DIRTGL), Data Direction Clear (DIRCLR) and Data Direction Set (DIRSET) registers.



**Tip:** The I/O pins are assembled in pin groups ("PORT groups") with up to 32 pins. Group 0 consists of the PA pins, group 1 is for the PB pins, etc. Each pin group has its own PORT registers, with a 0x80 address spacing. For example, the register address offset for the Data Direction (DIR) register for group 0 (PA00 to PA31) is 0x00, and the register address offset for the DIR register for group 1 (PB00 to PB31) is 0x80.

Bit	31	30	29	28	27	26	25	24
	DIR[31:24]							
Access	RW	RW	RW	RW	RW	RW	RW	RW
Reset	0	0	0	0	0	0	0	0
Bit	23	22	21	20	19	18	17	16
	DIR[23:16]							
Access	RW	RW	RW	RW	RW	RW	RW	RW
Reset	0	0	0	0	0	0	0	0
Bit	15	14	13	12	11	10	9	8
	DIR[15:8]							
Access	RW	RW	RW	RW	RW	RW	RW	RW
Reset	0	0	0	0	0	0	0	0
Bit	7	6	5	4	3	2	1	0
	DIR[7:0]							
Access	RW	RW	RW	RW	RW	RW	RW	RW
Reset	0	0	0	0	0	0	0	0

#### Bits 31:0 – DIR[31:0] Port Data Direction

These bits set the data direction for the individual I/O pins in the PORT group.

Value	Description
0	The corresponding I/O pin in the PORT group is configured as an input.
1	The corresponding I/O pin in the PORT group is configured as an output.

### 32.8.2 Data Direction Clear

**Name:** DIRCLR  
**Offset:** 0x04  
**Reset:** 0x00000000  
**Property:** PAC Write-Protection

This register allows the user to set one or more I/O pins as an input, without doing a read-modify-write operation. Changes in this register will also be reflected in the Data Direction (DIR), Data Direction Toggle (DIRTGL) and Data Direction Set (DIRSET) registers.



**Tip:** The I/O pins are assembled in pin groups ("PORT groups") with up to 32 pins. Group 0 consists of the PA pins, group 1 is for the PB pins, etc. Each pin group has its own PORT registers, with a 0x80 address spacing. For example, the register address offset for the Data Direction (DIR) register for group 0 (PA00 to PA31) is 0x00, and the register address offset for the DIR register for group 1 (PB00 to PB31) is 0x80.

Bit	31	30	29	28	27	26	25	24
DIRCLR[31:24]								
Access	RW	RW	RW	RW	RW	RW	RW	RW
Reset	0	0	0	0	0	0	0	0
Bit	23	22	21	20	19	18	17	16
DIRCLR[23:16]								
Access	RW	RW	RW	RW	RW	RW	RW	RW
Reset	0	0	0	0	0	0	0	0
Bit	15	14	13	12	11	10	9	8
DIRCLR[15:8]								
Access	RW	RW	RW	RW	RW	RW	RW	RW
Reset	0	0	0	0	0	0	0	0
Bit	7	6	5	4	3	2	1	0
DIRCLR[7:0]								
Access	RW	RW	RW	RW	RW	RW	RW	RW
Reset	0	0	0	0	0	0	0	0

#### Bits 31:0 – DIRCLR[31:0] Port Data Direction Clear

Writing a '0' to a bit has no effect.

Writing a '1' to a bit will clear the corresponding bit in the DIR register, which configures the I/O pin as an input.

Value	Description
0	The corresponding I/O pin in the PORT group will keep its configuration.
1	The corresponding I/O pin in the PORT group is configured as input.

# SAM D5x/E5x Family Data Sheet

## PORT - I/O Pin Controller

### 32.8.3 Data Direction Set

**Name:** DIRSET  
**Offset:** 0x08  
**Reset:** 0x00000000  
**Property:** PAC Write-Protection

This register allows the user to set one or more I/O pins as an output, without doing a read-modify-write operation. Changes in this register will also be reflected in the Data Direction (DIR), Data Direction Toggle (DIRTGL) and Data Direction Clear (DIRCLR) registers.



**Tip:** The I/O pins are assembled in pin groups ("PORT groups") with up to 32 pins. Group 0 consists of the PA pins, group 1 is for the PB pins, etc. Each pin group has its own PORT registers, with a 0x80 address spacing. For example, the register address offset for the Data Direction (DIR) register for group 0 (PA00 to PA31) is 0x00, and the register address offset for the DIR register for group 1 (PB00 to PB31) is 0x80.

Bit	31	30	29	28	27	26	25	24
DIRSET[31:24]								
Access	RW	RW	RW	RW	RW	RW	RW	RW
Reset	0	0	0	0	0	0	0	0
Bit	23	22	21	20	19	18	17	16
DIRSET[23:16]								
Access	RW	RW	RW	RW	RW	RW	RW	RW
Reset	0	0	0	0	0	0	0	0
Bit	15	14	13	12	11	10	9	8
DIRSET[15:8]								
Access	RW	RW	RW	RW	RW	RW	RW	RW
Reset	0	0	0	0	0	0	0	0
Bit	7	6	5	4	3	2	1	0
DIRSET[7:0]								
Access	RW	RW	RW	RW	RW	RW	RW	RW
Reset	0	0	0	0	0	0	0	0

#### Bits 31:0 – DIRSET[31:0] Port Data Direction Set

Writing '0' to a bit has no effect.

Writing '1' to a bit will set the corresponding bit in the DIR register, which configures the I/O pin as an output.

Value	Description
0	The corresponding I/O pin in the PORT group will keep its configuration.
1	The corresponding I/O pin in the PORT group is configured as an output.



# SAM D5x/E5x Family Data Sheet

## PORT - I/O Pin Controller

### 32.8.4 Data Direction Toggle

**Name:** DIRTGL  
**Offset:** 0x0C  
**Reset:** 0x00000000  
**Property:** PAC Write-Protection

This register allows the user to toggle the direction of one or more I/O pins, without doing a read-modify-write operation. Changes in this register will also be reflected in the Data Direction (DIR), Data Direction Set (DIRSET) and Data Direction Clear (DIRCLR) registers.



**Tip:** The I/O pins are assembled in pin groups ("PORT groups") with up to 32 pins. Group 0 consists of the PA pins, group 1 is for the PB pins, etc. Each pin group has its own PORT registers, with a 0x80 address spacing. For example, the register address offset for the Data Direction (DIR) register for group 0 (PA00 to PA31) is 0x00, and the register address offset for the DIR register for group 1 (PB00 to PB31) is 0x80.

Bit	31	30	29	28	27	26	25	24
	DIRTGL[31:24]							
Access	RW	RW	RW	RW	RW	RW	RW	RW
Reset	0	0	0	0	0	0	0	0
Bit	23	22	21	20	19	18	17	16
	DIRTGL[23:16]							
Access	RW	RW	RW	RW	RW	RW	RW	RW
Reset	0	0	0	0	0	0	0	0
Bit	15	14	13	12	11	10	9	8
	DIRTGL[15:8]							
Access	RW	RW	RW	RW	RW	RW	RW	RW
Reset	0	0	0	0	0	0	0	0
Bit	7	6	5	4	3	2	1	0
	DIRTGL[7:0]							
Access	RW	RW	RW	RW	RW	RW	RW	RW
Reset	0	0	0	0	0	0	0	0

#### Bits 31:0 – DIRTGL[31:0] Port Data Direction Toggle

Writing '0' to a bit has no effect.

Writing '1' to a bit will toggle the corresponding bit in the DIR register, which reverses the direction of the I/O pin.

Value	Description
0	The corresponding I/O pin in the PORT group will keep its configuration.
1	The direction of the corresponding I/O pin is toggled.

# SAM D5x/E5x Family Data Sheet

## PORT - I/O Pin Controller

### 32.8.5 Data Output Value

**Name:** OUT  
**Offset:** 0x10  
**Reset:** 0x00000000  
**Property:** PAC Write-Protection

This register sets the data output drive value for the individual I/O pins in the PORT.

This register can be manipulated without doing a read-modify-write operation by using the Data Output Value Clear (OUTCLR), Data Output Value Set (OUTSET), and Data Output Value Toggle (OUTTGL) registers.



**Tip:** The I/O pins are assembled in pin groups ("PORT groups") with up to 32 pins. Group 0 consists of the PA pins, group 1 is for the PB pins, etc. Each pin group has its own PORT registers, with a 0x80 address spacing. For example, the register address offset for the Data Direction (DIR) register for group 0 (PA00 to PA31) is 0x00, and the register address offset for the DIR register for group 1 (PB00 to PB31) is 0x80.

Bit	31	30	29	28	27	26	25	24
	OUT[31:24]							
Access	RW	RW	RW	RW	RW	RW	RW	RW
Reset	0	0	0	0	0	0	0	0
Bit	23	22	21	20	19	18	17	16
	OUT[23:16]							
Access	RW	RW	RW	RW	RW	RW	RW	RW
Reset	0	0	0	0	0	0	0	0
Bit	15	14	13	12	11	10	9	8
	OUT[15:8]							
Access	RW	RW	RW	RW	RW	RW	RW	RW
Reset	0	0	0	0	0	0	0	0
Bit	7	6	5	4	3	2	1	0
	OUT[7:0]							
Access	RW	RW	RW	RW	RW	RW	RW	RW
Reset	0	0	0	0	0	0	0	0

#### Bits 31:0 – OUT[31:0] PORT Data Output Value

For pins configured as outputs via the Data Direction register (DIR), these bits set the logical output drive level.

For pins configured as inputs via the Data Direction register (DIR) and with pull enabled via the Pull Enable bit in the Pin Configuration register (PINCFG.PULLEN), these bits will set the input pull direction.

Value	Description
0	The I/O pin output is driven low, or the input is connected to an internal pull-down.
1	The I/O pin output is driven high, or the input is connected to an internal pull-up.

# SAM D5x/E5x Family Data Sheet

## PORT - I/O Pin Controller

### 32.8.6 Data Output Value Clear

**Name:** OUTCLR  
**Offset:** 0x14  
**Reset:** 0x00000000  
**Property:** PAC Write-Protection

This register allows the user to set one or more output I/O pin drive levels low, without doing a read-modify-write operation. Changes in this register will also be reflected in the Data Output Value (OUT), Data Output Value Toggle (OUTTGL) and Data Output Value Set (OUTSET) registers.



**Tip:** The I/O pins are assembled in pin groups ("PORT groups") with up to 32 pins. Group 0 consists of the PA pins, group 1 is for the PB pins, etc. Each pin group has its own PORT registers, with a 0x80 address spacing. For example, the register address offset for the Data Direction (DIR) register for group 0 (PA00 to PA31) is 0x00, and the register address offset for the DIR register for group 1 (PB00 to PB31) is 0x80.

Bit	31	30	29	28	27	26	25	24
	OUTCLR[31:24]							
Access	RW	RW	RW	RW	RW	RW	RW	RW
Reset	0	0	0	0	0	0	0	0
Bit	23	22	21	20	19	18	17	16
	OUTCLR[23:16]							
Access	RW	RW	RW	RW	RW	RW	RW	RW
Reset	0	0	0	0	0	0	0	0
Bit	15	14	13	12	11	10	9	8
	OUTCLR[15:8]							
Access	RW	RW	RW	RW	RW	RW	RW	RW
Reset	0	0	0	0	0	0	0	0
Bit	7	6	5	4	3	2	1	0
	OUTCLR[7:0]							
Access	RW	RW	RW	RW	RW	RW	RW	RW
Reset	0	0	0	0	0	0	0	0

#### Bits 31:0 – OUTCLR[31:0] PORT Data Output Value Clear

Writing '0' to a bit has no effect.

Writing '1' to a bit will clear the corresponding bit in the OUT register. Pins configured as outputs via the Data Direction register (DIR) will be set to low output drive level. Pins configured as inputs via DIR and with pull enabled via the Pull Enable bit in the Pin Configuration register (PINCFG.PULLEN) will set the input pull direction to an internal pull-down.

Value	Description
0	The corresponding I/O pin in the PORT group will keep its configuration.
1	The corresponding I/O pin output is driven low, or the input is connected to an internal pull-down.

### 32.8.7 Data Output Value Set

**Name:** OUTSET  
**Offset:** 0x18  
**Reset:** 0x00000000  
**Property:** PAC Write-Protection

This register allows the user to set one or more output I/O pin drive levels high, without doing a read-modify-write operation. Changes in this register will also be reflected in the Data Output Value (OUT), Data Output Value Toggle (OUTTGL) and Data Output Value Clear (OUTCLR) registers.



**Tip:** The I/O pins are assembled in pin groups ("PORT groups") with up to 32 pins. Group 0 consists of the PA pins, group 1 is for the PB pins, etc. Each pin group has its own PORT registers, with a 0x80 address spacing. For example, the register address offset for the Data Direction (DIR) register for group 0 (PA00 to PA31) is 0x00, and the register address offset for the DIR register for group 1 (PB00 to PB31) is 0x80.

Bit	31	30	29	28	27	26	25	24
	OUTSET[31:24]							
Access	RW	RW	RW	RW	RW	RW	RW	RW
Reset	0	0	0	0	0	0	0	0
Bit	23	22	21	20	19	18	17	16
	OUTSET[23:16]							
Access	RW	RW	RW	RW	RW	RW	RW	RW
Reset	0	0	0	0	0	0	0	0
Bit	15	14	13	12	11	10	9	8
	OUTSET[15:8]							
Access	RW	RW	RW	RW	RW	RW	RW	RW
Reset	0	0	0	0	0	0	0	0
Bit	7	6	5	4	3	2	1	0
	OUTSET[7:0]							
Access	RW	RW	RW	RW	RW	RW	RW	RW
Reset	0	0	0	0	0	0	0	0

#### Bits 31:0 – OUTSET[31:0] PORT Data Output Value Set

Writing '0' to a bit has no effect.

Writing '1' to a bit will set the corresponding bit in the OUT register, which sets the output drive level high for I/O pins configured as outputs via the Data Direction register (DIR). For pins configured as inputs via Data Direction register (DIR) with pull enabled via the Pull Enable register (PULLEN), these bits will set the input pull direction to an internal pull-up.

Value	Description
0	The corresponding I/O pin in the group will keep its configuration.
1	The corresponding I/O pin output is driven high, or the input is connected to an internal pull-up.

# SAM D5x/E5x Family Data Sheet

## PORT - I/O Pin Controller

### 32.8.8 Data Output Value Toggle

**Name:** OUTTGL  
**Offset:** 0x1C  
**Reset:** 0x00000000  
**Property:** PAC Write-Protection

This register allows the user to toggle the drive level of one or more output I/O pins, without doing a read-modify-write operation. Changes in this register will also be reflected in the Data Output Value (OUT), Data Output Value Set (OUTSET) and Data Output Value Clear (OUTCLR) registers.



**Tip:** The I/O pins are assembled in pin groups ("PORT groups") with up to 32 pins. Group 0 consists of the PA pins, group 1 is for the PB pins, etc. Each pin group has its own PORT registers, with a 0x80 address spacing. For example, the register address offset for the Data Direction (DIR) register for group 0 (PA00 to PA31) is 0x00, and the register address offset for the DIR register for group 1 (PB00 to PB31) is 0x80.

Bit	31	30	29	28	27	26	25	24
OUTTGL[31:24]								
Access	RW	RW	RW	RW	RW	RW	RW	RW
Reset	0	0	0	0	0	0	0	0
Bit	23	22	21	20	19	18	17	16
OUTTGL[23:16]								
Access	RW	RW	RW	RW	RW	RW	RW	RW
Reset	0	0	0	0	0	0	0	0
Bit	15	14	13	12	11	10	9	8
OUTTGL[15:8]								
Access	RW	RW	RW	RW	RW	RW	RW	RW
Reset	0	0	0	0	0	0	0	0
Bit	7	6	5	4	3	2	1	0
OUTTGL[7:0]								
Access	RW	RW	RW	RW	RW	RW	RW	RW
Reset	0	0	0	0	0	0	0	0

#### Bits 31:0 – OUTTGL[31:0] PORT Data Output Value Toggle

Writing '0' to a bit has no effect.

Writing '1' to a bit will toggle the corresponding bit in the OUT register, which inverts the output drive level for I/O pins configured as outputs via the Data Direction register (DIR). For pins configured as inputs via Data Direction register (DIR) with pull enabled via the Pull Enable register (PULLEN), these bits will toggle the input pull direction.

Value	Description
0	The corresponding I/O pin in the PORT group will keep its configuration.
1	The corresponding OUT bit value is toggled.

# SAM D5x/E5x Family Data Sheet

## PORT - I/O Pin Controller

### 32.8.9 Data Input Value

**Name:** IN  
**Offset:** 0x20  
**Reset:** 0x00000000  
**Property:** -



**Tip:** The I/O pins are assembled in pin groups ("PORT groups") with up to 32 pins. Group 0 consists of the PA pins, group 1 is for the PB pins, etc. Each pin group has its own PORT registers, with a 0x80 address spacing. For example, the register address offset for the Data Direction (DIR) register for group 0 (PA00 to PA31) is 0x00, and the register address offset for the DIR register for group 1 (PB00 to PB31) is 0x80.

	Bit	31	30	29	28	27	26	25	24
		IN[31:24]							
Access		R	R	R	R	R	R	R	R
Reset		0	0	0	0	0	0	0	0
	Bit	23	22	21	20	19	18	17	16
		IN[23:16]							
Access		R	R	R	R	R	R	R	R
Reset		0	0	0	0	0	0	0	0
	Bit	15	14	13	12	11	10	9	8
		IN[15:8]							
Access		R	R	R	R	R	R	R	R
Reset		0	0	0	0	0	0	0	0
	Bit	7	6	5	4	3	2	1	0
		IN[7:0]							
Access		R	R	R	R	R	R	R	R
Reset		0	0	0	0	0	0	0	0

**Bits 31:0 – IN[31:0] PORT Data Input Value**

These bits are cleared when the corresponding I/O pin input sampler detects a logical low level on the input pin.

These bits are set when the corresponding I/O pin input sampler detects a logical high level on the input pin.

# SAM D5x/E5x Family Data Sheet

## PORT - I/O Pin Controller

### 32.8.10 Control

**Name:** CTRL  
**Offset:** 0x24  
**Reset:** 0x00000000  
**Property:** PAC Write-Protection



**Tip:** The I/O pins are assembled in pin groups ("PORT groups") with up to 32 pins. Group 0 consists of the PA pins, group 1 is for the PB pins, etc. Each pin group has its own PORT registers, with a 0x80 address spacing. For example, the register address offset for the Data Direction (DIR) register for group 0 (PA00 to PA31) is 0x00, and the register address offset for the DIR register for group 1 (PB00 to PB31) is 0x80.

	Bit	31	30	29	28	27	26	25	24
		SAMPLING[31:24]							
Access		RW	RW	RW	RW	RW	RW	RW	RW
Reset		0	0	0	0	0	0	0	0
	Bit	23	22	21	20	19	18	17	16
		SAMPLING[23:16]							
Access		RW	RW	RW	RW	RW	RW	RW	RW
Reset		0	0	0	0	0	0	0	0
	Bit	15	14	13	12	11	10	9	8
		SAMPLING[15:8]							
Access		RW	RW	RW	RW	RW	RW	RW	RW
Reset		0	0	0	0	0	0	0	0
	Bit	7	6	5	4	3	2	1	0
		SAMPLING[7:0]							
Access		RW	RW	RW	RW	RW	RW	RW	RW
Reset		0	0	0	0	0	0	0	0

#### Bits 31:0 – SAMPLING[31:0] Input Sampling Mode

Configures the input sampling functionality of the I/O pin input samplers, for pins configured as inputs via the Data Direction register (DIR).

The input samplers are enabled and disabled in sub-groups of eight. Thus if any pins within a byte request continuous sampling, all pins in that eight pin sub-group will be continuously sampled.

Value	Description
0	On demand sampling of I/O pin is enabled.
1	Continuous sampling of I/O pin is enabled.

# SAM D5x/E5x Family Data Sheet

## PORT - I/O Pin Controller

### 32.8.11 Write Configuration

**Name:** WRCONFIG  
**Offset:** 0x28  
**Reset:** 0x00000000  
**Property:** PAC Write-Protection, Write-Only



**Tip:** The I/O pins are assembled in pin groups ("PORT groups") with up to 32 pins. Group 0 consists of the PA pins, group 1 is for the PB pins, etc. Each pin group has its own PORT registers, with a 0x80 address spacing. For example, the register address offset for the Data Direction (DIR) register for group 0 (PA00 to PA31) is 0x00, and the register address offset for the DIR register for group 1 (PB00 to PB31) is 0x80.

This Write-only register is used to configure several pins simultaneously with the same configuration and/or peripheral multiplexing.

In order to avoid side effect of non-atomic access, 8-bit or 16-bit writes to this register will have no effect. Reading this register always returns zero.

Bit	31	30	29	28	27	26	25	24
	HWSEL	WRPINCFG		WRPMUX	PMUX[3:0]			
Access	W	W		W	W	W	W	W
Reset	0	0		0	0	0	0	0
Bit	23	22	21	20	19	18	17	16
		DRVSTR				PULLEN	INEN	PMUXEN
Access		W				W	W	W
Reset		0				0	0	0
Bit	15	14	13	12	11	10	9	8
	PINMASK[15:8]							
Access	W	W	W	W	W	W	W	W
Reset	0	0	0	0	0	0	0	0
Bit	7	6	5	4	3	2	1	0
	PINMASK[7:0]							
Access	W	W	W	W	W	W	W	W
Reset	0	0	0	0	0	0	0	0

**Bit 31 – HWSEL** Half-Word Select

This bit selects the half-word field of a 32-PORT group to be reconfigured in the atomic write operation. This bit will always read as zero.

Value	Description
0	The lower 16 pins of the PORT group will be configured.
1	The upper 16 pins of the PORT group will be configured.



**Bit 30 – WRPINCFG** Write PINCFG

This bit determines whether the atomic write operation will update the Pin Configuration register (PINCFGy) or not for all pins selected by the WRCONFIG.PINMASK and WRCONFIG.HWSEL bits. Writing '0' to this bit has no effect.

Writing '1' to this bit updates the configuration of the selected pins with the written WRCONFIG.DRVSTR, WRCONFIG.PULLEN, WRCONFIG.INEN, WRCONFIG.PMUXEN, and WRCONFIG.PINMASK values.

This bit will always read as zero.

Value	Description
0	The PINCFGy registers of the selected pins will not be updated.
1	The PINCFGy registers of the selected pins will be updated.

**Bit 28 – WRPMUX** Write PMUX

This bit determines whether the atomic write operation will update the Peripheral Multiplexing register (PMUXn) or not for all pins selected by the WRCONFIG.PINMASK and WRCONFIG.HWSEL bits. Writing '0' to this bit has no effect.

Writing '1' to this bit updates the pin multiplexer configuration of the selected pins with the written WRCONFIG.PMUX value.

This bit will always read as zero.

Value	Description
0	The PMUXn registers of the selected pins will not be updated.
1	The PMUXn registers of the selected pins will be updated.

**Bits 27:24 – PMUX[3:0]** Peripheral Multiplexing

These bits determine the new value written to the Peripheral Multiplexing register (PMUXn) for all pins selected by the WRCONFIG.PINMASK and WRCONFIG.HWSEL bits, when the WRCONFIG.WRPMUX bit is set.

These bits will always read as zero.

**Bit 22 – DRVSTR** Output Driver Strength Selection

This bit determines the new value written to PINCFGy.DRVSTR for all pins selected by the WRCONFIG.PINMASK and WRCONFIG.HWSEL bits, when the WRCONFIG.WRPINCFG bit is set. This bit will always read as zero.

**Bit 18 – PULLEN** Pull Enable

This bit determines the new value written to PINCFGy.PULLEN for all pins selected by the WRCONFIG.PINMASK and WRCONFIG.HWSEL bits, when the WRCONFIG.WRPINCFG bit is set. This bit will always read as zero.

**Bit 17 – INEN** Input Enable

This bit determines the new value written to PINCFGy.INEN for all pins selected by the WRCONFIG.PINMASK and WRCONFIG.HWSEL bits, when the WRCONFIG.WRPINCFG bit is set. This bit will always read as zero.

**Bit 16 – PMUXEN** Peripheral Multiplexer Enable

This bit determines the new value written to PINCFGy.PMUXEN for all pins selected by the WRCONFIG.PINMASK and WRCONFIG.HWSEL bits, when the WRCONFIG.WRPINCFG bit is set. This bit will always read as zero.

# SAM D5x/E5x Family Data Sheet

## PORT - I/O Pin Controller

---

**Bits 15:0 – PINMASK[15:0]** Pin Mask for Multiple Pin Configuration

These bits select the pins to be configured within the half-word group selected by the WRCONFIG.HWSEL bit.

These bits will always read as zero.

Value	Description
0	The configuration of the corresponding I/O pin in the half-word group will be left unchanged.
1	The configuration of the corresponding I/O pin in the half-word PORT group will be updated.

### 32.8.12 Event Input Control

**Name:** EVCTRL  
**Offset:** 0x2C  
**Reset:** 0x00000000  
**Property:** PAC Write-Protection



**Tip:** The I/O pins are assembled in pin groups ("PORT groups") with up to 32 pins. Group 0 consists of the PA pins, group 1 is for the PB pins, etc. Each pin group has its own PORT registers, with a 0x80 address spacing. For example, the register address offset for the Data Direction (DIR) register for group 0 (PA00 to PA31) is 0x00, and the register address offset for the DIR register for group 1 (PB00 to PB31) is 0x80.

There are up to four input event pins for each PORT group. Each byte of this register addresses one Event input pin.

	Bit	31	30	29	28	27	26	25	24
		PORTEIx		EVACTx[1:0]		PIDx[4:0]			
Access		RW	RW	RW	RW	RW	RW	RW	RW
Reset		0	0	0	0	0	0	0	0
	Bit	23	22	21	20	19	18	17	16
		PORTEIx		EVACTx[1:0]		PIDx[4:0]			
Access		RW	RW	RW	RW	RW	RW	RW	RW
Reset		0	0	0	0	0	0	0	0
	Bit	15	14	13	12	11	10	9	8
		PORTEIx		EVACTx[1:0]		PIDx[4:0]			
Access		RW	RW	RW	RW	RW	RW	RW	RW
Reset		0	0	0	0	0	0	0	0
	Bit	7	6	5	4	3	2	1	0
		PORTEIx		EVACTx[1:0]		PIDx[4:0]			
Access		RW	RW	RW	RW	RW	RW	RW	RW
Reset		0	0	0	0	0	0	0	0

**Bits 31,23,15,7 – PORTEIx** PORT Event Input Enable x [x = 3..0]

Value	Description
0	The event action x (EVACTx) will not be triggered on any incoming event.
1	The event action x (EVACTx) will be triggered on any incoming event.

**Bits 30:29, 22:21,14:13,6:5 – EVACTx** PORT Event Action x [x = 3..0]

These bits define the event action the PORT will perform on event input x. See also [Table 32-4](#).

**Bits 28:24,20:16,12:8,4:0 – PIDx** PORT Event Pin Identifier x [x = 3..0]

These bits define the I/O pin on which the event action will be performed, according to [Table 32-5](#).

**Table 32-4. PORT Event x Action ( x = [3..0] )**

Value	Name	Description
0x0	OUT	Output register of pin will be set to level of event.
0x1	SET	Set output register of pin on event.
0x2	CLR	Clear output register of pin on event.
0x3	TGL	Toggle output register of pin on event.

**Table 32-5. PORT Event x Pin Identifier ( x = [3..0] )**

Value	Name	Description
0x0	PIN0	Event action to be executed on PIN 0.
0x1	PIN1	Event action to be executed on PIN 1.
...	...	...
0x31	PIN31	Event action to be executed on PIN 31.

### 32.8.13 Peripheral Multiplexing n

**Name:** PMUX  
**Offset:** 0x30 + n\*0x01 [n=0..15]  
**Reset:** 0x00  
**Property:** PAC Write-Protection



**Tip:** The I/O pins are assembled in pin groups ("PORT groups") with up to 32 pins. Group 0 consists of the PA pins, group 1 is for the PB pins, etc. Each pin group has its own PORT registers, with a 0x80 address spacing. For example, the register address offset for the Data Direction (DIR) register for group 0 (PA00 to PA31) is 0x00, and the register address offset for the DIR register for group 1 (PB00 to PB31) is 0x80.

There are up to 16 Peripheral Multiplexing registers in each group, one for every set of two subsequent I/O lines. The n denotes the number of the set of I/O lines.

	Bit	7	6	5	4	3	2	1	0
		PMUXO[3:0]				PMUXE[3:0]			
Access		RW	RW	RW	RW	RW	RW	RW	RW
Reset		0	0	0	0	0	0	0	0

#### Bits 7:4 – PMUXO[3:0] Peripheral Multiplexing for Odd-Numbered Pin

These bits select the peripheral function for odd-numbered pins ( $2*n + 1$ ) of a PORT group, if the corresponding PINCFGy.PMUXEN bit is '1'.

Not all possible values for this selection may be valid. For more details, refer to the *I/O Multiplexing and Considerations*.

PMUXO[3:0]	Name	Description
0x0	A	Peripheral function A selected
0x1	B	Peripheral function B selected
0x2	C	Peripheral function C selected
0x3	D	Peripheral function D selected
0x4	E	Peripheral function E selected
0x5	F	Peripheral function F selected
0x6	G	Peripheral function G selected
0x7	H	Peripheral function H selected
0x8	I	Peripheral function I selected
0x9	J	Peripheral function J selected
0xA	K	Peripheral function K selected
0xB	L	Peripheral function L selected
0xC	M	Peripheral function M selected

# SAM D5x/E5x Family Data Sheet

## PORT - I/O Pin Controller

.....continued

PMUXO[3:0]	Name	Description
0xD	N	Peripheral function N selected
0xE-0xF	-	Reserved

### Bits 3:0 – PMUXE[3:0] Peripheral Multiplexing for Even-Numbered Pin

These bits select the peripheral function for even-numbered pins ( $2^n$ ) of a PORT group, if the corresponding PINCFGy.PMUXEN bit is '1'.

Not all possible values for this selection may be valid. For more details, refer to the *I/O Multiplexing and Considerations*.

PMUXE[3:0]	Name	Description
0x0	A	Peripheral function A selected
0x1	B	Peripheral function B selected
0x2	C	Peripheral function C selected
0x3	D	Peripheral function D selected
0x4	E	Peripheral function E selected
0x5	F	Peripheral function F selected
0x6	G	Peripheral function G selected
0x7	H	Peripheral function H selected
0x8	I	Peripheral function I selected
0x9	J	Peripheral function J selected
0xA	K	Peripheral function K selected
0xB	L	Peripheral function L selected
0xC	M	Peripheral function M selected
0xD	N	Peripheral function N selected
0xE-0xF	-	Reserved

### Related Links

[6. I/O Multiplexing and Considerations](#)

### 32.8.14 Pin Configuration

**Name:** PINCFG  
**Offset:** 0x40 + n\*0x01 [n=0..31]  
**Reset:** 0x00  
**Property:** PAC Write-Protection



**Tip:** The I/O pins are assembled in pin groups ("PORT groups") with up to 32 pins. Group 0 consists of the PA pins, group 1 is for the PB pins, etc. Each pin group has its own PORT registers, with a 0x80 address spacing. For example, the register address offset for the Data Direction (DIR) register for group 0 (PA00 to PA31) is 0x00, and the register address offset for the DIR register for group 1 (PB00 to PB31) is 0x80.

There are up to 32 Pin Configuration registers in each PORT group, one for each I/O line.

	7	6	5	4	3	2	1	0
		DRVSTR				PULLEN	INEN	PMUXEN
Access		RW				RW	RW	RW
Reset		0				0	0	0

#### Bit 6 – DRVSTR Output Driver Strength Selection

This bit controls the output driver strength of an I/O pin configured as an output.

Value	Description
0	Pin drive strength is set to normal drive strength.
1	Pin drive strength is set to stronger drive strength.

#### Bit 2 – PULLEN Pull Enable

This bit enables the internal pull-up or pull-down resistor of an I/O pin configured as an input.

Value	Description
0	Internal pull resistor is disabled, and the input is in a high-impedance configuration.
1	Internal pull resistor is enabled, and the input is driven to a defined logic level in the absence of external input.

#### Bit 1 – INEN Input Enable

This bit controls the input buffer of an I/O pin configured as either an input or output.

Writing a zero to this bit disables the input buffer completely, preventing read-back of the Physical Pin state when the pin is configured as either an input or output.

Value	Description
0	Input buffer for the I/O pin is disabled, and the input value will not be sampled.
1	Input buffer for the I/O pin is enabled, and the input value will be sampled when required.

#### Bit 0 – PMUXEN Peripheral Multiplexer Enable

This bit enables or disables the peripheral multiplexer selection set in the Peripheral Multiplexing register (PMUXn) to enable or disable alternative peripheral control over an I/O pin direction and output drive value.

Writing a zero to this bit allows the PORT to control the pad direction via the Data Direction register (DIR) and output drive value via the Data Output Value register (OUT). The peripheral multiplexer value in

# SAM D5x/E5x Family Data Sheet

## PORT - I/O Pin Controller

PMUXn is ignored. Writing '1' to this bit enables the peripheral selection in PMUXn to control the pad. In this configuration, the Physical Pin state may still be read from the Data Input Value register (IN) if PINCFGn.INEN is set.

Value	Description
0	The peripheral multiplexer selection is disabled, and the PORT registers control the direction and output drive value.
1	The peripheral multiplexer selection is enabled, and the selected peripheral function controls the direction and output drive value.



### 33. SERCOM – Serial Communication Interface

#### 33.1 Overview

There are up to eight instances of the Serial Communication interface (SERCOM) peripheral.

A SERCOM can be configured to support a number of modes: I<sup>2</sup>C, SPI, and USART. When an instance of SERCOM is configured and enabled, all of the resources of that SERCOM instance will be dedicated to the selected mode.

The SERCOM serial engine consists of a transmitter and receiver, baud-rate generator and address matching functionality. It can use the internal generic clock or an external clock. Using an external clock allows the SERCOM to be operated in all Sleep modes.

##### Related Links

- [34. SERCOM USART - SERCOM Synchronous and Asynchronous Receiver and Transmitter](#)
- [35. SERCOM SPI – SERCOM Serial Peripheral Interface](#)
- [36. SERCOM I2C – Inter-Integrated Circuit](#)
- [6.2.6 SERCOM I2C Configurations](#)

#### 33.2 Features

- Interface for Configuring into one of the Following:
  - Inter-Integrated Circuit (I<sup>2</sup>C) two-wire serial interface
  - System Management Bus (SMBus™) compatible
  - Serial Peripheral Interface (SPI)
  - Universal Synchronous/Asynchronous Receiver/Transmitter (USART)
- Single Transmit Buffer and Double Receive Buffer
- Baud-rate Generator
- Address Match/mask Logic
- Operational in all Sleep modes with an External Clock Source
- Can be used with DMA
- 32-bit Extension for Better System Bus Utilization

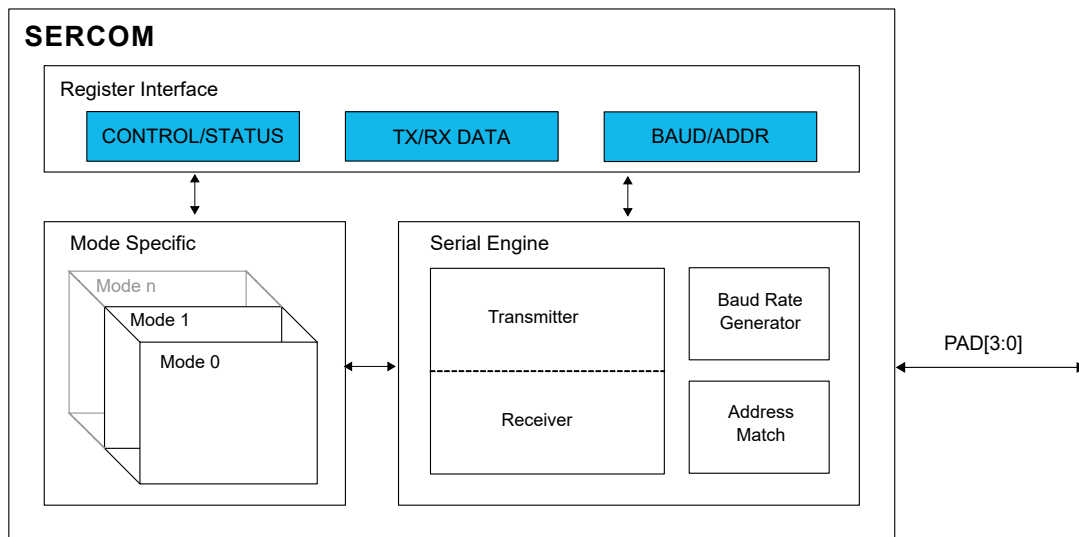
See the Related Links for full feature lists of the interface configurations.

##### Related Links

- [34. SERCOM USART - SERCOM Synchronous and Asynchronous Receiver and Transmitter](#)
- [35. SERCOM SPI – SERCOM Serial Peripheral Interface](#)
- [36. SERCOM I2C – Inter-Integrated Circuit](#)
- [6.2.6 SERCOM I2C Configurations](#)

### 33.3 Block Diagram

Figure 33-1. SERCOM Block Diagram



### 33.4 Signal Description

See the respective SERCOM mode chapters for details.

#### Related Links

- [34. SERCOM USART - SERCOM Synchronous and Asynchronous Receiver and Transmitter](#)
- [35. SERCOM SPI – SERCOM Serial Peripheral Interface](#)
- [36. SERCOM I2C – Inter-Integrated Circuit](#)

### 33.5 Product Dependencies

In order to use this peripheral, other parts of the system must be configured correctly, as described below.

#### 33.5.1 I/O Lines

Using the SERCOM I/O lines requires the I/O pins to be configured using port configuration (PORT).

The SERCOM has four internal pads, PAD[3:0], and the signals from I<sup>2</sup>C, SPI and USART are routed through these SERCOM pads through a multiplexer. The configuration of the multiplexer is available from the different SERCOM modes. Refer to the mode specific chapters for additional information.

#### Related Links

- [34. SERCOM USART - SERCOM Synchronous and Asynchronous Receiver and Transmitter](#)
- [35. SERCOM SPI – SERCOM Serial Peripheral Interface](#)
- [36. SERCOM I2C – Inter-Integrated Circuit](#)
- [32. PORT - I/O Pin Controller](#)
- [34.3 Block Diagram](#)

#### 33.5.2 Power Management

The SERCOM can operate in any Sleep mode provided the selected clock source is running. SERCOM interrupts can be configured to wake the device from sleep modes.

### Related Links

[18. PM – Power Manager](#)

### 33.5.3 Clocks

The SERCOM bus clock (CLK\_SERCOMx\_APB) can be enabled and disabled in the Main Clock Controller. Refer to *Peripheral Clock Masking* for details and default status of this clock.

The SERCOM uses two generic clocks: GCLK\_SERCOMx\_CORE and GCLK\_SERCOMx\_SLOW. The core clock (GCLK\_SERCOMx\_CORE) is required to clock the SERCOM while working as a master. The slow clock (GCLK\_SERCOMx\_SLOW) is only required for certain functions. See specific mode chapters for details.

These clocks must be configured and enabled in the Generic Clock Controller (GCLK) before using the SERCOM.

The generic clocks are asynchronous to the user interface clock (CLK\_SERCOMx\_APB). Due to this asynchronicity, writing to certain registers will require synchronization between the clock domains. Refer to [33.6.8 Synchronization](#) for details.

### Related Links

[14. GCLK - Generic Clock Controller](#)

[15. MCLK – Main Clock](#)

### 33.5.4 DMA

The DMA request lines are connected to the DMA Controller (DMAC). The DMAC must be configured before the SERCOM DMA requests are used.

### Related Links

[22. DMAC – Direct Memory Access Controller](#)

### 33.5.5 Interrupts

The interrupt request line is connected to the Interrupt Controller (NVIC). The NVIC must be configured before the SERCOM interrupts are used.

### Related Links

[10.2 Nested Vector Interrupt Controller](#)

### 33.5.6 Events

Not applicable.

### 33.5.7 Debug Operation

When the CPU is halted in Debug mode, this peripheral will continue normal operation. If the peripheral is configured to require periodical service by the CPU through interrupts or similar, improper operation or data loss may result during debugging. This peripheral can be forced to halt operation during debugging - refer to the Debug Control (DBGCTRL) register for details.

### 33.5.8 Register Access Protection

All registers with write access can be write-protected optionally by the Peripheral Access Controller (PAC), except for the following registers:

- Interrupt Flag Clear and Status register (INTFLAG)
- Status register (STATUS)

- Data register (DATA)
- Address register (ADDR)

Optional write protection by the Peripheral Access Controller (PAC) is denoted by the "PAC Write Protection" property in each individual register description.

PAC write protection does not apply to accesses through an external debugger.

### Related Links

[27. PAC - Peripheral Access Controller](#)

### 33.5.9 Analog Connections

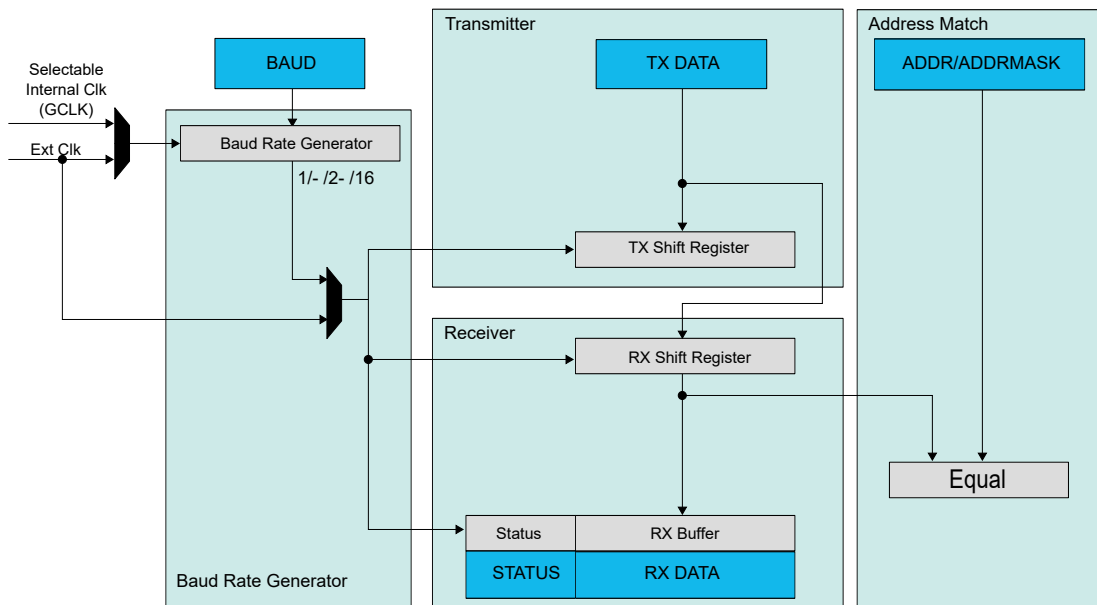
Not applicable.

## 33.6 Functional Description

### 33.6.1 Principle of Operation

The basic structure of the SERCOM serial engine is shown in [Figure 33-2](#). Labels in capital letters are synchronous to the system clock and accessible by the CPU; labels in lowercase letters can be configured to run on the GCLK\_SERCOMx\_CORE clock or an external clock.

**Figure 33-2. SERCOM Serial Engine**



The transmitter consists of a single write buffer and a Shift register.

The receiver consists of a one-level (I<sup>2</sup>C), two-level (USART, SPI) receive buffer and a Shift register.

The baud-rate generator is capable of running on the GCLK\_SERCOMx\_CORE clock or an external clock.

Address matching logic is included for SPI and I<sup>2</sup>C operation.

### 33.6.2 Basic Operation

#### 33.6.2.1 Initialization

The SERCOM must be configured to the desired mode by writing the Operating Mode bits in the Control A register (CTRLA.MODE). Refer to table SERCOM Modes for details.

**Table 33-1. SERCOM Modes**

CTRLA.MODE	Description
0x0	USART with external clock
0x1	USART with internal clock
0x2	SPI in slave operation
0x3	SPI in master operation
0x4	I <sup>2</sup> C slave operation
0x5	I <sup>2</sup> C master operation
0x6-0x7	Reserved

For further initialization information, see the respective SERCOM mode chapters:

#### Related Links

[34. SERCOM USART - SERCOM Synchronous and Asynchronous Receiver and Transmitter](#)

[35. SERCOM SPI – SERCOM Serial Peripheral Interface](#)

[36. SERCOM I2C – Inter-Integrated Circuit](#)

#### 33.6.2.2 Enabling, Disabling, and Resetting

This peripheral is enabled by writing '1' to the Enable bit in the Control A register (CTRLA.ENABLE), and disabled by writing '0' to it.

Writing '1' to the Software Reset bit in the Control A register (CTRLA.SWRST) will reset all registers of this peripheral to their initial states, except the DBGCTRL register, and the peripheral is disabled.

Refer to the CTRLA register description for details.

#### 33.6.2.3 Clock Generation – Baud-Rate Generator

The baud-rate generator, as shown in [Figure 33-3](#), generates internal clocks for asynchronous and synchronous communication. The output frequency ( $f_{\text{BAUD}}$ ) is determined by the Baud register (BAUD) setting and the baud reference frequency ( $f_{\text{ref}}$ ). The baud reference clock is the serial engine clock, and it can be internal or external.

For asynchronous communication, the /16 (divide-by-16) output is used when transmitting, whereas the /1 (divide-by-1) output is used while receiving.

For synchronous communication, the /2 (divide-by-2) output is used.

This functionality is automatically configured, depending on the selected operating mode.

**Figure 33-3. Baud Rate Generator**

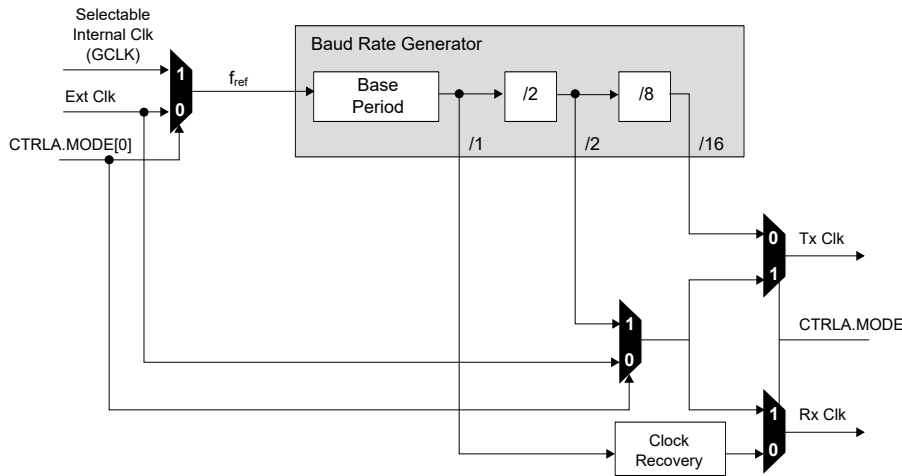


Table 33-2 contains equations for the baud rate (in bits per second) and the BAUD register value for each operating mode.

For asynchronous operation, there is one mode: *arithmetic mode*, the BAUD register value is 16 bits (0 to 65,535). *fractional mode*, the BAUD register value is 13 bits, while the fractional adjustment is 3 bits. In this mode the BAUD setting must be greater than or equal to 1.

For synchronous operation, the BAUD register value is 8 bits (0 to 255).

**Table 33-2. Baud Rate Equations**

Operating Mode	Condition	Baud Rate (Bits Per Second)	BAUD Register Value Calculation
Asynchronous Arithmetic	$f_{BAUD} \leq \frac{f_{ref}}{16}$	$f_{BAUD} = \frac{f_{ref}}{16} \left( 1 - \frac{BAUD}{65536} \right)$	$BAUD = 65536 \cdot \left( 1 - 16 \cdot \frac{f_{BAUD}}{f_{ref}} \right)$
Asynchronous Fractional	$f_{BAUD} \leq \frac{f_{ref}}{S}$	$f_{BAUD} = \frac{f_{ref}}{S \cdot \left( BAUD + \frac{FP}{8} \right)}$	$BAUD = \frac{f_{ref}}{S \cdot f_{BAUD}} - \frac{FP}{8}$
Synchronous	$f_{BAUD} \leq \frac{f_{ref}}{2}$	$f_{BAUD} = \frac{f_{ref}}{2 \cdot (BAUD + 1)}$	$BAUD = \frac{f_{ref}}{2 \cdot f_{BAUD}} - 1$

S - Number of samples per bit, which can be 16, 8, or 3.

The Asynchronous Fractional option is used for auto-baud detection.

The baud rate error is represented by the following formula:

$$\text{Error} = 1 - \left( \frac{\text{ExpectedBaudRate}}{\text{ActualBaudRate}} \right)$$

### 33.6.2.3.1 Asynchronous Arithmetic Mode BAUD Value Selection

The formula given for  $f_{BAUD}$  calculates the average frequency over 65536  $f_{ref}$  cycles. Although the BAUD register can be set to any value between 0 and 65536, the actual average frequency of  $f_{BAUD}$  over a single frame is more granular. The BAUD register values that will affect the average frequency over a single frame lead to an integer increase in the cycles per frame (CPF)

$$CPF = \frac{f_{ref}}{f_{BAUD}} (D + S)$$

where

- $D$  represent the data bits per frame
- $S$  represent the sum of start and first stop bits, if present.

Table 33-3 shows the BAUD register value versus baud frequency  $f_{\text{BAUD}}$  at a serial engine frequency of 48 MHz. This assumes a  $D$  value of 8 bits and an  $S$  value of 2 bits (10 bits, including start and stop bits).

**Table 33-3. BAUD Register Value vs. Baud Frequency**

BAUD Register Value	Serial Engine CPF	$f_{\text{BAUD}}$ at 100MHz Serial Engine Frequency ( $f_{\text{REF}}$ )
0 – 406	161	6.211 MHz
407 – 808	162	6.211 MHz
809 – 1205	163	6.173 MHz
...	...	...
65206	31775	31.47 kHz
65207	31872	31.38 kHz
65208	31969	31.28 kHz

### 33.6.3 Additional Features

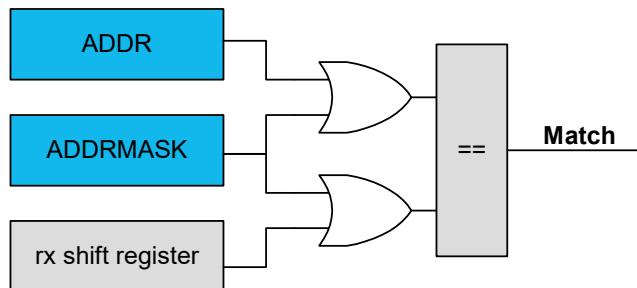
#### 33.6.3.1 Address Match and Mask

The SERCOM address match and mask feature is capable of matching either one address, two unique addresses, or a range of addresses with a mask, based on the mode selected. The match uses seven or eight bits, depending on the mode.

##### 33.6.3.1.1 Address With Mask

An address written to the Address bits in the Address register (ADDR.ADDR), and a mask written to the Address Mask bits in the Address register (ADDR.ADDRMASK) will yield an address match. All bits that are masked are not included in the match. Note that writing the ADDR.ADDRMASK to 'all zeros' will match a single unique address, while writing ADDR.ADDRMASK to 'all ones' will result in all addresses being accepted.

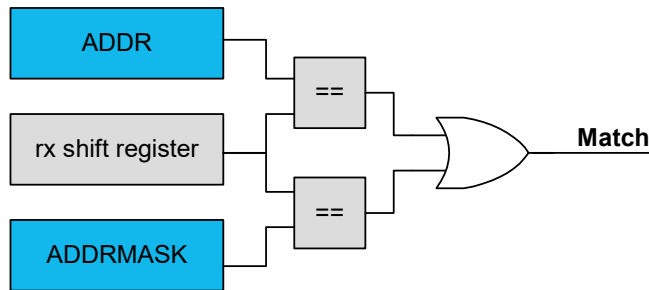
**Figure 33-4. Address With Mask**



##### 33.6.3.1.2 Two Unique Addresses

The two addresses written to ADDR and ADDRMASK will cause a match.

**Figure 33-5. Two Unique Addresses**



### 33.6.3.1.3 Address Range

The range of addresses between and including ADDR.ADDR and ADDR.ADDRMASK will cause a match. ADDR.ADDR and ADDR.ADDRMASK can be set to any two addresses, with ADDR.ADDR acting as the upper limit and ADDR.ADDRMASK acting as the lower limit.

**Figure 33-6. Address Range**



### 33.6.4 DMA Operation

The available DMA interrupts and their depend on the operation mode of the SERCOM peripheral. Refer to the Functional Description sections of the respective SERCOM mode.

#### Related Links

- [34. SERCOM USART - SERCOM Synchronous and Asynchronous Receiver and Transmitter](#)
- [35. SERCOM SPI – SERCOM Serial Peripheral Interface](#)
- [36. SERCOM I2C – Inter-Integrated Circuit](#)

### 33.6.5 Interrupts

Interrupt sources are mode specific. See the respective SERCOM mode chapters for details.

Each interrupt source has its own Interrupt flag.

The Interrupt flag in the Interrupt Flag Status and Clear register (INTFLAG) will be set when the Interrupt condition is met.

Each interrupt can be individually enabled by writing '1' to the corresponding bit in the Interrupt Enable Set register (INTENSET), and disabled by writing '1' to the corresponding bit in the Interrupt Enable Clear register (INTENCLR).

An interrupt request is generated when the Interrupt flag is set and the corresponding interrupt is enabled. The interrupt request remains active until either the Interrupt flag is cleared, the interrupt is disabled, or the SERCOM is reset. For details on clearing Interrupt flags, refer to the INTFLAG register description.

The value of INTFLAG indicates which Interrupt condition occurred. The user must read the INTFLAG register to determine which Interrupt condition is present.

**Note:** Interrupts must be globally enabled for interrupt requests.

#### Related Links

- [10.2 Nested Vector Interrupt Controller](#)



### 33.6.6 Events

Not applicable.

### 33.6.7 Sleep Mode Operation

The peripheral can operate in any Sleep mode where the selected serial clock is running. This clock can be external or generated by the internal baud-rate generator.

The SERCOM interrupts can be used to wake-up the device from Sleep modes. Refer to the different SERCOM mode chapters for details.

### 33.6.8 Synchronization

Due to asynchronicity between the main clock domain and the peripheral clock domains, some registers need to be synchronized when written or read.

Required write synchronization is denoted by the "Write-Synchronized" property in the register description.

Required read synchronization is denoted by the "Read-Synchronized" property in the register description.

#### Related Links

[13.3 Register Synchronization](#)

## 34. SERCOM USART - SERCOM Synchronous and Asynchronous Receiver and Transmitter

### 34.1 Overview

The Universal Synchronous and Asynchronous Receiver and Transmitter (USART) is one of the available modes in the Serial Communication Interface (SERCOM).

The USART uses the SERCOM transmitter and receiver, see [34.3 Block Diagram](#). Labels in uppercase letters are synchronous to CLK\_SERCOMx\_APB and accessible for CPU. Labels in lowercase letters can be programmed to run on the internal generic clock or an external clock.

The transmitter consists of a single write buffer, a Shift register, and control logic for different frame formats. The write buffer support data transmission without any delay between frames. The receiver consists of a two-level receive buffer and a Shift register. Status information of the received data is available for error checking. Data and clock recovery units ensure robust synchronization and noise filtering during asynchronous data reception.

#### Related Links

[33. SERCOM – Serial Communication Interface](#)

### 34.2 USART Features

- Full-duplex Operation
- Asynchronous (with Clock Reconstruction) or Synchronous Operation
- Internal or External Clock source for Asynchronous and Synchronous Operation
- Baud-rate Generator
- Supports Serial Frames with 5, 6, 7, 8 or 9 Data bits and 1 or 2 Stop bits
- Odd or Even Parity Generation and Parity Check
- Selectable LSB- or MSB-first Data Transfer
- Buffer Overflow and Frame Error Detection
- Noise Filtering, Including False Start bit Detection and Digital Low-pass Filter
- Collision Detection
- Can Operate in all Sleep modes
- Operation at Speeds up to Half the System Clock for Internally Generated Clocks
- Operation at Speeds up to the System Clock for Externally Generated Clocks
- RTS and CTS Flow Control
- IrDA Modulation and Demodulation up to 115.2kbps
- LIN Master Support
- LIN Slave Support
  - Auto-baud and break character detection
- ISO 7816 T=0 or T=1 protocols for Smart Card Interfacing
- RS485 Support
- Start-of-frame detection
- Two-Level Receive Buffer

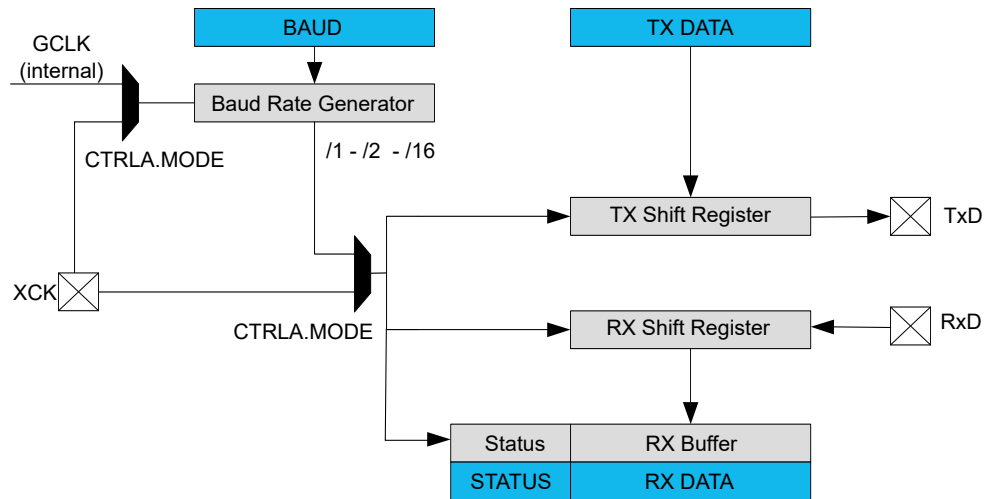
- Can work with DMA
- 32-bit Extension for Better System Bus Utilization

### Related Links

[33.2 Features](#)

## 34.3 Block Diagram

Figure 34-1. USART Block Diagram



## 34.4 Signal Description

Table 34-1. SERCOM USART Signals

Signal Name	Type	Description
PAD[3:0]	Digital I/O	General SERCOM pins

One signal can be mapped to one of several pins.

### Related Links

[6. I/O Multiplexing and Considerations](#)

## 34.5 Product Dependencies

In order to use this peripheral, other parts of the system must be configured correctly, as described below.

### 34.5.1 I/O Lines

Using the USART's I/O lines requires the I/O pins to be configured using the I/O Pin Controller (PORT).

When the SERCOM is used in USART mode, the SERCOM controls the direction and value of the I/O pins according to the table below. If the receiver or transmitter is disabled, these pins can be used for other purposes.

# SAM D5x/E5x Family Data Sheet

## SERCOM USART - SERCOM Synchronous and Asyn...

**Table 34-2. USART Pin Configuration**

Pin	Pin Configuration
TxD	Output
RxD	Input
XCK	Output or input

The combined configuration of PORT and the Transmit Data Pinout and Receive Data Pinout bit fields in the Control A register (CTRLA.TXPO and CTRLA.RXPO, respectively) will define the physical position of the USART signals in [Table 34-2](#).

### Related Links

[32. PORT - I/O Pin Controller](#)

### 34.5.2 Power Management

This peripheral can continue to operate in any Sleep mode where its source clock is running. The interrupts can wake-up the device from Sleep modes.

### Related Links

[18. PM – Power Manager](#)

### 34.5.3 Clocks

The SERCOM bus clock (CLK\_SERCOMx\_APB) can be enabled and disabled in the Main Clock Controller. Refer to *Peripheral Clock Masking* for details and default status of this clock.

A generic clock (GCLK\_SERCOMx\_CORE) is required to clock the SERCOMx\_CORE. This clock must be configured and enabled in the Generic Clock Controller before using the SERCOMx\_CORE. Refer to *GCLK - Generic Clock Controller* for details.

This generic clock is asynchronous to the bus clock (CLK\_SERCOMx\_APB). Therefore, writing to certain registers will require synchronization to the clock domains. Refer to *Synchronization* for further details.

### Related Links

[15.6.2.6 Peripheral Clock Masking](#)

[34.6.6 Synchronization](#)

[14. GCLK - Generic Clock Controller](#)

### 34.5.4 DMA

The DMA request lines are connected to the DMA Controller (DMAC). In order to use DMA requests with this peripheral the DMAC must be configured first. Refer to *DMAC – Direct Memory Access Controller* for details.

### Related Links

[22. DMAC – Direct Memory Access Controller](#)

### 34.5.5 Interrupts

The interrupt request line is connected to the Interrupt Controller. In order to use interrupt requests of this peripheral, the Interrupt Controller (NVIC) must be configured first. Refer to *Nested Vector Interrupt Controller* for details.

### Related Links

### [10.2 Nested Vector Interrupt Controller](#)

#### **34.5.6 Events**

Not applicable.

#### **34.5.7 Debug Operation**

When the CPU is halted in Debug mode, this peripheral will continue normal operation. If the peripheral is configured to require periodical service by the CPU through interrupts or similar, improper operation or data loss may result during debugging. This peripheral can be forced to halt operation during debugging - refer to the Debug Control (DBGCTRL) register for details.

##### **Related Links**

[34.8.14 DBGCTRL](#)

#### **34.5.8 Register Access Protection**

Registers with write access can be write-protected optionally by the Peripheral Access Controller (PAC).

PAC write protection is not available for the following registers:

- Interrupt Flag Clear and Status register (INTFLAG)
- Status register (STATUS)
- Data register (DATA)

Optional PAC write protection is denoted by the "PAC Write-Protection" property in each individual register description.

Write-protection does not apply to accesses through an external debugger.

##### **Related Links**

[27. PAC - Peripheral Access Controller](#)

#### **34.5.9 Analog Connections**

Not applicable.

### **34.6 Functional Description**

#### **34.6.1 Principle of Operation**

The USART uses the following lines for data transfer:

- RXD for receiving
- TXD for transmitting
- XCK for the transmission clock in synchronous operation

USART data transfer is frame based. A serial frame consists of:

- 1 start bit
- From 5 to 9 data bits (MSB or LSB first)
- No, even or odd parity bit
- 1 or 2 stop bits

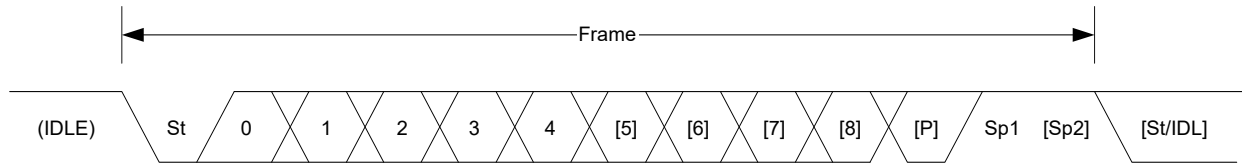
A frame starts with the Start bit followed by one character of Data bits. If enabled, the parity bit is inserted after the Data bits and before the first Stop bit. After the stop bit(s) of a frame, either the next frame can

# SAM D5x/E5x Family Data Sheet

## SERCOM USART - SERCOM Synchronous and Asyn...

follow immediately, or the communication line can return to the Idle (high) state. The figure below illustrates the possible frame formats. Brackets denote optional bits.

**Figure 34-2. Frame Formats**



**St** Start bit. Signal is always low.

**n, [n]** Data bits. 0 to [5..9]

**[P]** Parity bit. Either odd or even.

**Sp, [Sp]** Stop bit. Signal is always high.

**IDLE** No frame is transferred on the communication line. Signal is always high in this state.

### 34.6.2 Basic Operation

#### 34.6.2.1 Initialization

The following registers are enable-protected, meaning they can only be written when the USART is disabled (CTRL.ENABLE=0):

- Control A register (CTRLA), except the Enable (ENABLE) and Software Reset (SWRST) bits.
- Control B register (CTRLB), except the Receiver Enable (RXEN) and Transmitter Enable (TXEN) bits.
- Baud register (BAUD)

When the USART is enabled or is being enabled (CTRLA.ENABLE=1), any writing attempt to these registers will be discarded. If the peripheral is being disabled, writing to these registers will be executed after disabling is completed. Enable-protection is denoted by the "Enable-Protection" property in the register description.

Before the USART is enabled, it must be configured by these steps:

1. Select either external (0x0) or internal clock (0x1) by writing the Operating Mode value in the CTRLA register (CTRLA.MODE).
2. Select either Asynchronous (0) or Synchronous (1) Communication mode by writing the Communication Mode bit in the CTRLA register (CTRLA.CMODE).
3. Select pin for receive data by writing the Receive Data Pinout value in the CTRLA register (CTRLA.RXPO).
4. Select pads for the transmitter and external clock by writing the Transmit Data Pinout bit in the CTRLA register (CTRLA.TXPO).
5. Configure the Character Size field in the CTRLB register (CTRLB.CHSIZE) for character size.
6. Set the Data Order bit in the CTRLA register (CTRLA.DORD) to determine MSB- or LSB-first data transmission.
7. To use parity mode:
  - 7.1. Enable Parity mode by writing 0x1 to the Frame Format field in the CTRLA register (CTRLA.FORM).

- 7.2. Configure the Parity Mode bit in the CTRLB register (CTRLB.PMODE) for even or odd parity.
8. Configure the number of stop bits in the Stop Bit Mode bit in the CTRLB register (CTRLB.SBMODE).
9. When using an internal clock, write the Baud register (BAUD) to generate the desired baud rate.
10. Enable the transmitter and receiver by writing '1' to the Receiver Enable and Transmitter Enable bits in the CTRLB register (CTRLB.RXEN and CTRLB.TXEN).

### 34.6.2.2 Enabling, Disabling, and Resetting

This peripheral is enabled by writing '1' to the Enable bit in the Control A register (CTRLA.ENABLE), and disabled by writing '0' to it.

Writing '1' to the Software Reset bit in the Control A register (CTRLA.SWRST) will reset all registers of this peripheral to their initial states, except the DBGCTRL register, and the peripheral is disabled.

Refer to the CTRLA register description for details.

### 34.6.2.3 Clock Generation and Selection

For both Synchronous and Asynchronous modes, the clock used for shifting and sampling data can be generated internally by the SERCOM baud-rate generator or supplied externally through the XCK line.

The Synchronous mode is selected by writing a '1' to the Communication Mode bit in the Control A register (CTRLA.CMODE), the Asynchronous mode is selected by writing a zero to CTRLA.CMODE.

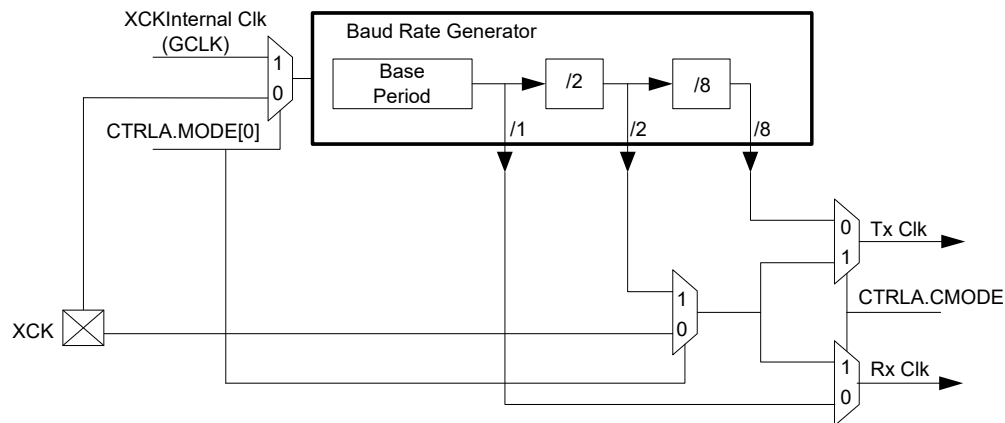
The internal clock source is selected by writing 0x1 to the Operation Mode bit field in the Control A register (CTRLA.MODE), the external clock source is selected by writing 0x0 to CTRLA.MODE.

The SERCOM baud-rate generator is configured as in the figure below.

In Asynchronous mode (CTRLA.CMODE=0), the 16-bit Baud register value is used.

In Synchronous mode (CTRLA.CMODE=1), the eight LSBs of the Baud register are used. Refer to *Clock Generation – Baud-Rate Generator* for details on configuring the baud rate.

**Figure 34-3. Clock Generation**



### Related Links

- [33.6.2.3 Clock Generation – Baud-Rate Generator](#)
- [33.6.2.3.1 Asynchronous Arithmetic Mode BAUD Value Selection](#)

#### 34.6.2.3.1 Synchronous Clock Operation

In Synchronous mode, the CTRLA.MODE bit field determines whether the transmission clock line (XCK) serves either as input or output. The dependency between clock edges, data sampling, and data change

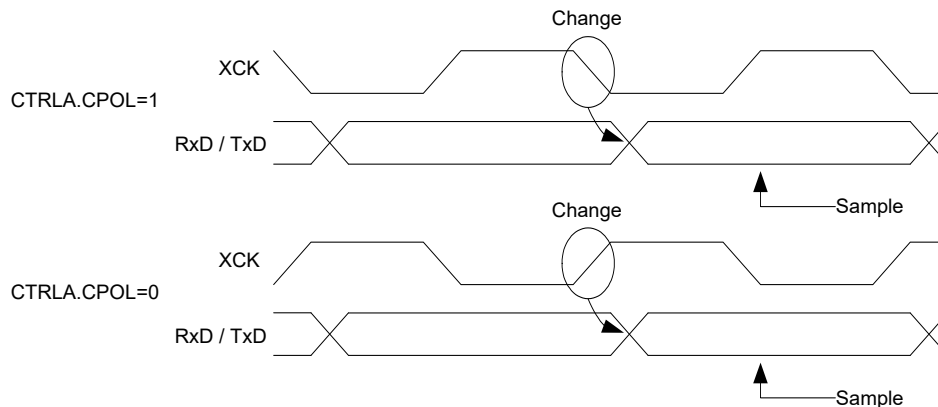
is the same for internal and external clocks. Data input on the RxD pin is sampled at the opposite XCK clock edge when data is driven on the TxD pin.

The Clock Polarity bit in the Control A register (CTRLA.CPOL) selects which XCK clock edge is used for RxD sampling, and which is used for TxD change:

When CTRLA.CPOL is '0', the data will be changed on the rising edge of XCK, and sampled on the falling edge of XCK.

When CTRLA.CPOL is '1', the data will be changed on the falling edge of XCK, and sampled on the rising edge of XCK.

**Figure 34-4. Synchronous Mode XCK Timing**



When the clock is provided through XCK (CTRLA.MODE=0x0), the Shift registers operate directly on the XCK clock. This means that XCK is not synchronized with the system clock and, therefore, can operate at frequencies up to the system frequency.

#### 34.6.2.4 Data Register

The USART Transmit Data register (TxDATA) and USART Receive Data register (RxDATA) share the same I/O address, referred to as the Data register (DATA). Writing the DATA register will update the TxDATA register. Reading the DATA register will return the contents of the RxDATA register.

#### 34.6.2.5 Data Transmission

Data transmission is initiated by writing the data to be sent into the DATA register. Then, the data in TxDATA will be moved to the Shift register when the Shift register is empty and ready to send a new frame. After the Shift register is loaded with data, the data frame will be transmitted.

When the entire data frame including Stop bit(s) has been transmitted and no new data was written to DATA, the Transmit Complete Interrupt flag in the Interrupt Flag Status and Clear register (INTFLAG.TXC) will be set, and the optional interrupt will be generated.

The Data Register Empty flag in the Interrupt Flag Status and Clear register (INTFLAG.DRE) indicates that the register is empty and ready for new data. The DATA register should only be written to when INTFLAG.DRE is set.

##### 34.6.2.5.1 Disabling the Transmitter

The transmitter is disabled by writing '0' to the Transmitter Enable bit in the CTRLB register (CTRLB.TXEN).

Disabling the transmitter will complete only after any ongoing and pending transmissions are completed, i.e., there is no data in the Transmit Shift register and TxDATA to transmit.



### 34.6.2.6 Data Reception

The receiver accepts data when a valid Start bit is detected. Each bit following the Start bit will be sampled according to the baud rate or XCK clock, and shifted into the receive Shift register until the first Stop bit of a frame is received. The second Stop bit will be ignored by the receiver.

When the first Stop bit is received and a complete serial frame is present in the Receive Shift register, the contents of the Shift register will be moved into the two-level receive buffer. Then, the Receive Complete Interrupt flag in the Interrupt Flag Status and Clear register (INTFLAG.RXC) will be set, and the optional interrupt will be generated.

The received data can be read from the DATA register when the Receive Complete Interrupt flag is set.

#### 34.6.2.6.1 Disabling the Receiver

Writing '0' to the Receiver Enable bit in the CTRLB register (CTRLB.RXEN) will disable the receiver, flush the two-level receive buffer, and data from ongoing receptions will be lost.

#### 34.6.2.6.2 Error Bits

The USART receiver has three error bits in the Status (STATUS) register: Frame Error (FERR), Buffer Overflow (BUFOVF), and Parity Error (PERR). Once an error happens, the corresponding error bit will be set until it is cleared by writing '1' to it. These bits are also cleared automatically when the receiver is disabled.

There are two methods for buffer overflow notification, selected by the Immediate Buffer Overflow Notification bit in the Control A register (CTRLA.IBON):

When CTRLA.IBON=1, STATUS.BUFOVF is raised immediately upon buffer overflow. Software can then empty the receive FIFO by reading RxDATA, until the Receiver Complete Interrupt flag (INTFLAG.RXC) is cleared.

When CTRLA.IBON=0, the Buffer Overflow condition is attending data through the receive FIFO. After the received data is read, STATUS.BUFOVF will be set along with INTFLAG.RXC.

#### 34.6.2.6.3 Asynchronous Data Reception

The USART includes a clock recovery and data recovery unit for handling asynchronous data reception.

The clock recovery logic can synchronize the incoming asynchronous serial frames at the RxD pin to the internally generated baud-rate clock.

The data recovery logic samples and applies a low-pass filter to each incoming bit, thereby improving the noise immunity of the receiver.

#### 34.6.2.6.4 Asynchronous Operational Range

The operational range of the asynchronous reception depends on the accuracy of the internal baud-rate clock, the rate of the incoming frames, and the frame size (in number of bits). In addition, the operational range of the receiver is depending on the difference between the received bit rate and the internally generated baud rate. If the baud rate of an external transmitter is too high or too low compared to the internally generated baud rate, the receiver will not be able to synchronize the frames to the start bit.

There are two possible sources for a mismatch in baud rate: First, the reference clock will always have some minor instability. Second, the baud-rate generator cannot always do an exact division of the reference clock frequency to get the baud rate desired. In this case, the BAUD register value should be set to give the lowest possible error. Refer to *Clock Generation – Baud-Rate Generator* for details.

Recommended maximum receiver baud-rate errors for various character sizes are shown in the table below.

# SAM D5x/E5x Family Data Sheet

## SERCOM USART - SERCOM Synchronous and Asyn...

**Table 34-3. Asynchronous Receiver Error for 16-fold Oversampling**

D (Data bits+Parity)	R <sub>SLOW</sub> [%]	R <sub>FAST</sub> [%]	Max. total error [%]	Recommended max. Rx error [%]
5	94.12	107.69	+5.88/-7.69	±2.5
6	94.92	106.67	+5.08/-6.67	±2.0
7	95.52	105.88	+4.48/-5.88	±2.0
8	96.00	105.26	+4.00/-5.26	±2.0
9	96.39	104.76	+3.61/-4.76	±1.5
10	96.70	104.35	+3.30/-4.35	±1.5

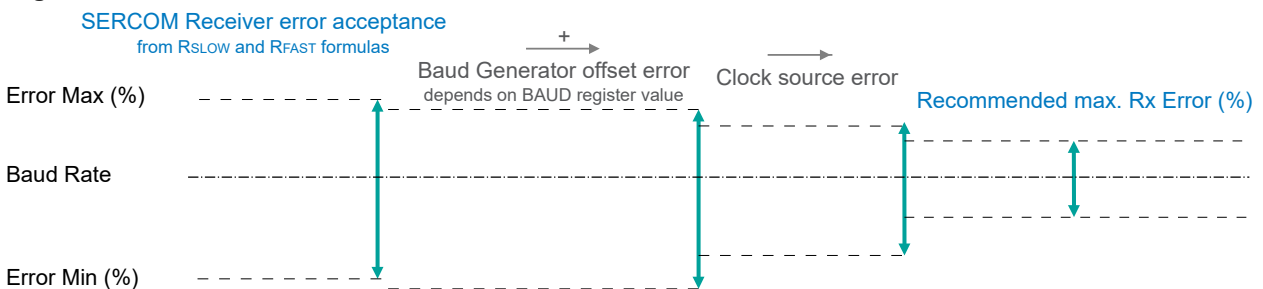
The following equations calculate the ratio of the incoming data rate and internal receiver baud rate:

$$R_{\text{SLOW}} = \frac{(D + 1)S}{S - 1 + D \cdot S + S_F} \quad , \quad R_{\text{FAST}} = \frac{(D + 2)S}{(D + 1)S + S_M}$$

- $R_{\text{SLOW}}$  is the ratio of the slowest incoming data rate that can be accepted in relation to the receiver baud rate
- $R_{\text{FAST}}$  is the ratio of the fastest incoming data rate that can be accepted in relation to the receiver baud rate
- $D$  is the sum of character size and parity size ( $D = 5$  to  $10$  bits)
- $S$  is the number of samples per bit ( $S = 16, 8$  or  $3$ )
- $S_F$  is the first sample number used for majority voting ( $S_F = 7, 3,$  or  $2$ ) when CTRLA.SAMPA=0.
- $S_M$  is the middle sample number used for majority voting ( $S_M = 8, 4,$  or  $2$ ) when CTRLA.SAMPA=0.

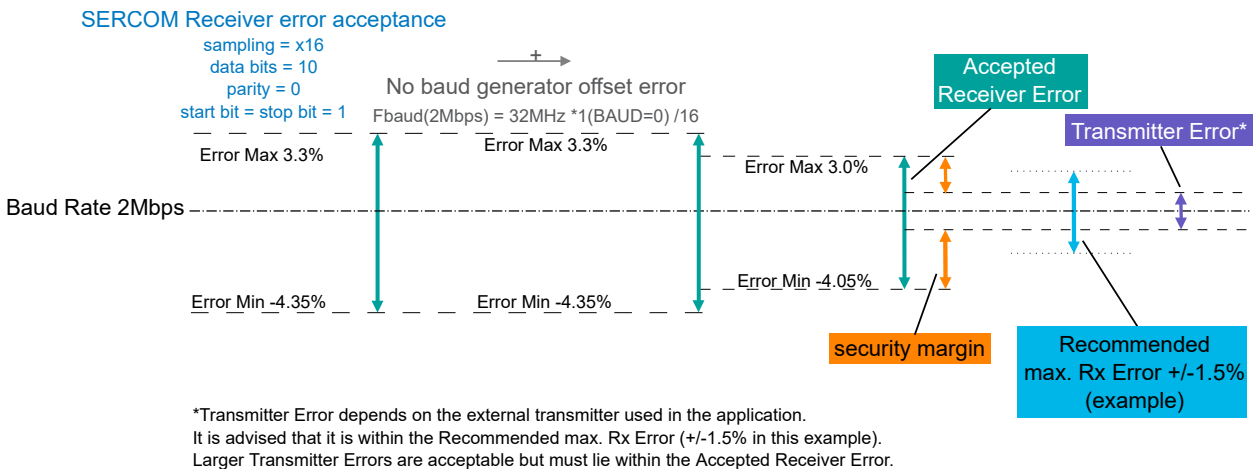
The recommended maximum Rx Error assumes that the receiver and transmitter equally divide the maximum total error. Its connection to the SERCOM Receiver error acceptance is depicted in this figure:

**Figure 34-5. USART Rx Error Calculation**



The recommendation values in the table above accommodate errors of the clock source and the baud generator. The following figure gives an example for a baud rate of 3Mbps:

**Figure 34-6. USART Rx Error Calculation Example**



### Related Links

- [33.6.2.3 Clock Generation – Baud-Rate Generator](#)
- [33.6.2.3.1 Asynchronous Arithmetic Mode BAUD Value Selection](#)

## 34.6.3 Additional Features

### 34.6.3.1 Parity

Even or odd parity can be selected for error checking by writing 0x1 to the Frame Format bit field in the Control A register (CTRLA.FORM).

If *even parity* is selected (CTRLB.PMODE=0), the Parity bit of an outgoing frame is '1' if the data contains an odd number of bits that are '1', making the total number of '1' even.

If *odd parity* is selected (CTRLB.PMODE=1), the Parity bit of an outgoing frame is '1' if the data contains an even number of bits that are '0', making the total number of '1' odd.

When parity checking is enabled, the parity checker calculates the parity of the data bits in incoming frames and compares the result with the Parity bit of the corresponding frame. If a parity error is detected, the Parity Error bit in the Status register (STATUS.PERR) is set.

### 34.6.3.2 Hardware Handshaking

The USART features an out-of-band hardware handshaking flow control mechanism, implemented by connecting the RTS and CTS pins with the remote device, as shown in the figure below.

**Figure 34-7. Connection with a Remote Device for Hardware Handshaking**



Hardware handshaking is only available in the following configuration:

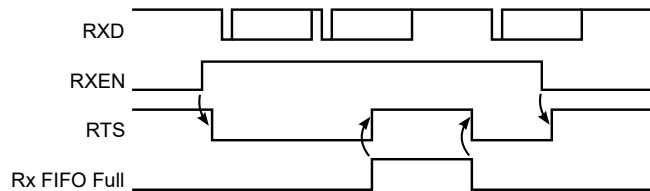
- USART with internal clock (CTRLA.MODE=1),
- Asynchronous mode (CTRLA.CMODE=0), and
- Flow control pinout (CTRLA.TXPO=2).

# SAM D5x/E5x Family Data Sheet

## SERCOM USART - SERCOM Synchronous and Asyn...

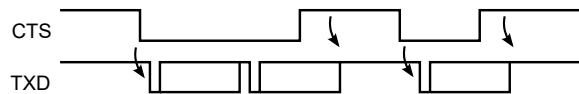
When the receiver is disabled or the receive FIFO is full, the receiver will drive the RTS pin high. This notifies the remote device to stop transfer after the ongoing transmission. Enabling and disabling the receiver by writing to CTRLB.RXEN will set/clear the RTS pin after a synchronization delay. When the receive FIFO goes full, RTS will be set immediately and the frame being received will be stored in the Shift register until the receive FIFO is no longer full.

**Figure 34-8. Receiver Behavior when Operating with Hardware Handshaking**



The current CTS Status is in the STATUS register (STATUS.CTS). Character transmission will start only if STATUS.CTS=0. When CTS is set, the transmitter will complete the ongoing transmission and stop transmitting.

**Figure 34-9. Transmitter Behavior when Operating with Hardware Handshaking**



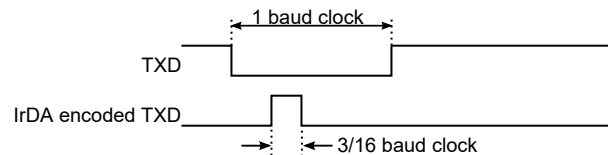
### 34.6.3.3 IrDA Modulation and Demodulation

Transmission and reception can be encoded IrDA compliant up to 115.2 kb/s. IrDA modulation and demodulation work in the following configuration:

- IrDA encoding enabled (CTRLB.ENC=1),
- Asynchronous mode (CTRLA.CMODE=0),
- and 16x sample rate (CTRLA.SAMPRT[0]=0).

During transmission, each low bit is transmitted as a high pulse. The pulse width is 3/16 of the baud rate period, as illustrated in the figure below.

**Figure 34-10. IrDA Transmit Encoding**



The reception decoder has two main functions.

The first is to synchronize the incoming data to the IrDA baud rate counter. Synchronization is performed at the start of each zero pulse.

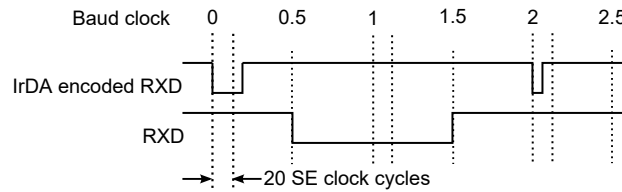
The second main function is to decode incoming Rx data. If a pulse width meets the minimum length set by configuration (RXPL.RXPL), it is accepted. When the baud rate counter reaches its middle value (1/2 bit length), it is transferred to the receiver.

**Note:** Note that the polarity of the transmitter and receiver are opposite: During transmission, a '0' bit is transmitted as a '1' pulse. During reception, an accepted '0' pulse is received as a '0' bit.

**Example:** The figure below illustrates reception where RXPL.RXPL is set to 19. This indicates that the pulse width should be at least 20 SE clock cycles. When using BAUD=0xE666 or 160 SE cycles per bit, this corresponds to 2/16 baud clock as

minimum pulse width required. In this case the first bit is accepted as a '0', the second bit is a '1', and the third bit is also a '1'. A low pulse is rejected since it does not meet the minimum requirement of 2/16 baud clock.

**Figure 34-11. IrDA Receive Decoding**



### 34.6.3.4 Break Character Detection and Auto-Baud/LIN Slave

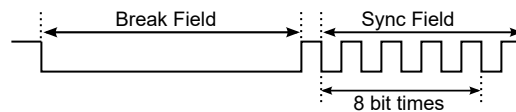
Break character detection and auto-baud are available in this configuration:

- Auto-baud frame format (CTRLA.FORM = 0x04 or 0x05),
- Asynchronous mode (CTRLA.CMODE = 0),
- and 16x sample rate using fractional baud rate generation (CTRLA.SAMPR = 1).

The USART uses a break detection threshold of greater than 11 nominal bit times at the configured baud rate. At any time, if more than 11 consecutive dominant bits are detected on the bus, the USART detects a Break Field. When a break field has been detected, the Receive Break Interrupt Flag (INTFLAG.RXBRK) is set and the USART expects the sync field character to be 0x55. This field is used to update the actual baud rate in order to stay synchronized. If the received sync character is not 0x55, then the Inconsistent Sync Field error flag (STATUS.ISF) is set along with the Error Interrupt Flag (INTFLAG.ERROR), and the baud rate is unchanged.

The auto-baud follows the LIN format. All LIN Frames start with a Break Field followed by a Sync Field.

**Figure 34-12. LIN Break and Sync Fields**



After a break field is detected and the Start bit of the sync field is detected, a counter is started. The counter is then incremented for the next 8 bit times of the sync field. At the end of these 8 bit times, the counter is stopped. At this moment, the 13 Most Significant bits of the counter (value divided by 8) give the new clock divider (BAUD.BAUD), and the 3 Least Significant bits of this value (the remainder) give the new Fractional Part (BAUD.FP).

When the sync field has been received, the clock divider (BAUD.BAUD) and the Fractional Part (BAUD.FP) are updated after a synchronization delay. After the break and sync fields are received, multiple characters of data can be received.

### 34.6.3.5 LIN Master

LIN master is available with the following configuration:

- LIN master format (CTRLA.FORM = 0x02)
- Asynchronous mode (CTRLA.CMODE = 0)
- 16x sample rate using fractional baud rate generation (CTRLA.SAMPR = 1)

LIN frames start with a header transmitted by the master. The header consists of the break, sync, and identifier fields. After the master transmits the header, the addressed slave will respond with 1-8 bytes of data plus checksum.

**Figure 34-13. LIN Frame Format**



Using the LIN command field (CTRLB.LINCMD), the complete header can be automatically transmitted, or software can control transmission of the various header components.

When CTRLB.LINCMD=0x1, software controls transmission of the LIN header. In this case, software uses the following sequence.

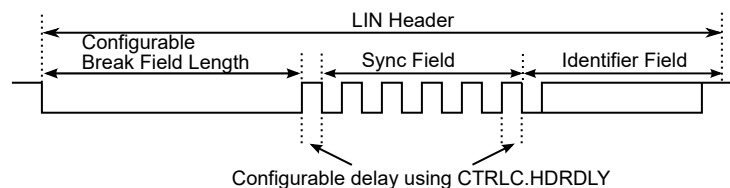
- CTRLB.LINCMD is written to 0x1.
- DATA register written to 0x00. This triggers transmission of the break field by hardware. Note that writing the DATA register with any other value will also result in the transmission of the break field by hardware.
- DATA register written to 0x55. The 0x55 value (sync) is transmitted.
- DATA register written to the identifier. The identifier is transmitted.

When CTRLB.LINCMD=0x2, hardware controls transmission of the LIN header. In this case, software uses the following sequence.

- CTRLB.LINCMD is written to 0x2.
- DATA register written to the identifier. This triggers transmission of the complete header by hardware. First the break field is transmitted. Next, the sync field is transmitted, and finally the identifier is transmitted.

In LIN master mode, the length of the break field is programmable using the break length field (CTRLC.BRKLEN). When the LIN header command is used (CTRLB.LINCMD=0x2), the delay between the break and sync fields, in addition to the delay between the sync and ID fields are configurable using the header delay field (CTRLC.HDRDLY). When manual transmission is used (CTRLB.LINCMD=0x1), software controls the delay between break and sync.

**Figure 34-14. LIN Header Generation**



After header transmission is complete, the slave responds with 1-8 data bytes plus checksum.

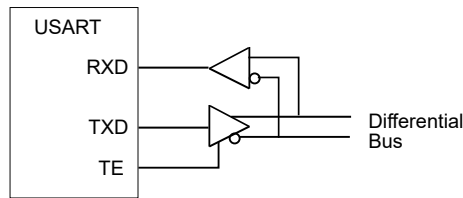
### 34.6.3.6 RS485

RS485 is available with the following configuration:

- USART frame format (CTRLA.FORM = 0x00 or 0x01)
- RS485 pinout (CTRLA.TXPO=0x3).

The RS485 feature enables control of an external line driver as shown in the figure below. While operating in RS485 mode, the transmit enable pin (TE) is driven high when the transmitter is active.

**Figure 34-15. RS485 Bus Connection**



The TE pin will remain high for the complete frame including stop bit(s). If a Guard Time is programmed in the Control C register (CTRLC.GTIME), the line will remain driven after the last character completion. The following figure shows a transfer with one stop bit and CTRLC.GTIME=3.

**Figure 34-16. Example of TE Drive with Guard Time**



The Transmit Complete interrupt flag (INTFLAG.TXC) will be raised after the guard time is complete and TE goes low.

### 34.6.3.7 ISO 7816 for Smart Card Interfacing

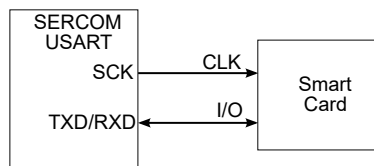
The SERCOM USART features an ISO/IEC 7816-compatible operating mode. This mode permits interfacing with smart cards and Security Access Modules (SAM) communicating through an ISO 7816 link. Both T=0 and T=1 protocols defined by the ISO 7816 specification are supported.

ISO 7816 is available with the following configuration:

- ISO 7816 format (CTRLA.FORM = 0x07)
- Inverse transmission and reception (CTRLA.RXINV=1 and CTRLA.TXINV=1)
- Single bidirectional data line (CTRLA.TXPO and CTRLA.RXPO configured to use the same data pin)
- Even parity (CTRLB.PMODE=0)
- 8-bit character size (CTRLB.CHSIZE=0)
- T=0 (CTRLA.CMODE=1) or T=1 (CTRLA.CMODE=0)

ISO 7816 is a half duplex communication on a single bidirectional line. The USART connects to a smart card as shown below. The output is only driven when the USART is transmitting. The USART is considered as the master of the communication as it generates the clock.

**Figure 34-17. Connection of a Smart Card to the SERCOM USART**



ISO 7816 characters are specified as 8 bits with even parity. The USART must be configured accordingly.

The USART cannot operate concurrently in both receiver and transmitter modes as the communication is unidirectional. It has to be configured according to the required mode by enabling or disabling either the receiver or the transmitter as desired. Enabling both the receiver and the transmitter at the same time in ISO 7816 mode may lead to unpredictable results.

The ISO 7816 specification defines an inverse transmission format. Data bits of the character must be transmitted on the I/O line at their negative value (CTRLA.RXINV=1 and CTRLA.TXINV=1).

### Protocol T=0

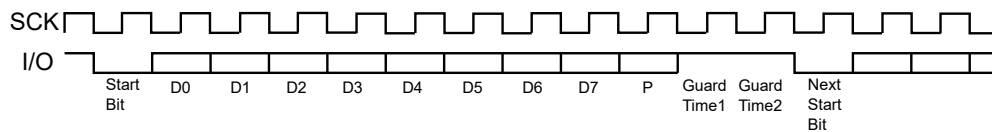
In T=0 protocol, a character is made up of:

- one start bit,
- eight data bits,
- one parity bit
- and one guard time, which lasts two bit times.

The transfer is synchronous (CTRLA.CMODE=1). The transmitter shifts out the bits and does not drive the I/O line during the guard time. Additional guard time can be added by programming the Guard Time (CTRLC.GTIME).

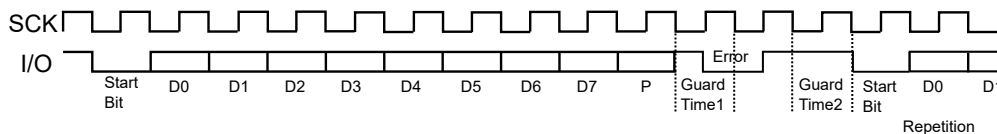
If no parity error is detected, the I/O line remains during the guard time and the transmitter can continue with the transmission of the next character, as shown in the figure below.

**Figure 34-18. T=0 Protocol without Parity Error**



If a parity error is detected by the receiver, it drives the I/O line to 0 during the guard time, as shown in the next figure. This error bit is also named NACK, for Non Acknowledge. In this case, the character lasts 1 bit time more, as the guard time length is the same and is added to the error bit time, which lasts 1 bit time.

**Figure 34-19. T=0 Protocol with Parity Error**



When the USART is the receiver and it detects a parity error, the parity error bit in the Status Register (STATUS.PERR) is set and the character is not written to the receive FIFO.

### Receive Error Counter

The receiver also records the total number of errors (receiver parity errors and NACKs from the remote transmitter) up to a maximum of 255. This can be read in the Receive Error Count (RXERRCNT) register. RXERRCNT is automatically cleared on read.

### Receive NACK Inhibit

The receiver can also be configured to inhibit error generation. This can be achieved by setting the Inhibit Not Acknowledge (CTRLC.INACK) bit. If CTRLC.INACK is 1, no error signal is driven on the I/O line even if a parity error is detected. Moreover, if CTRLC.INACK is set, the erroneous received character is stored in the receive FIFO, and the STATUS.PERR bit is set. Inhibit not acknowledge (CTRLC.INACK) takes priority over disable successive receive NACK (CTRLC.DSNACK).

### Transmit Character Repetition

When the USART is transmitting a character and gets a NACK, it can automatically repeat the character before moving on to the next character. Repetition is enabled by writing the Maximum Iterations register (CTRLC.MAXITER) to a non-zero value. The USART repeats the character the number of times specified in CTRLC.MAXITER.



When the USART repetition number reaches the programmed value in CTRLC.MAXITER, the STATUS.ITER bit is set and the internal iteration counter is reset. If the repetition of the character is acknowledged by the receiver before the maximum iteration is reached, the repetitions are stopped and the iteration counter is cleared.

### Disable Successive Receive NACK

The receiver can limit the number of successive NACKs sent back to the remote transmitter. This is programmed by setting the Disable Successive NACK bit (CTRLC.DSNACK). The maximum number of NACKs transmitted is programmed in the CTRLC.MAXITER field. As soon as the maximum is reached, the character is considered as correct, an acknowledge is sent on the line, the STATUS.ITER bit is set and the internal iteration counter is reset.

### Protocol T=1

When operating in ISO7816 protocol T=1, the transmission is asynchronous (CTRL1.CMODE=0) with one or two stop bits. After the stop bits are sent, the transmitter does not drive the I/O line.

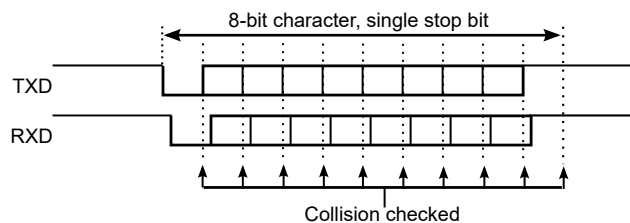
Parity is generated when transmitting and checked when receiving. Parity error detection sets the STATUS.PERR bit, and the erroneous character is written to the receive FIFO. When using T=1 protocol, the receiver does not signal errors on the I/O line and the transmitter does not retransmit.

#### 34.6.3.8 Collision Detection

When the receiver and transmitter are connected either through pin configuration or externally, transmit collision can be detected after selecting the Collision Detection Enable bit in the CTRLB register (CTRLB.COLDEN=1). To detect collision, the receiver and transmitter must be enabled (CTRLB.RXEN=1 and CTRLB.TXEN=1).

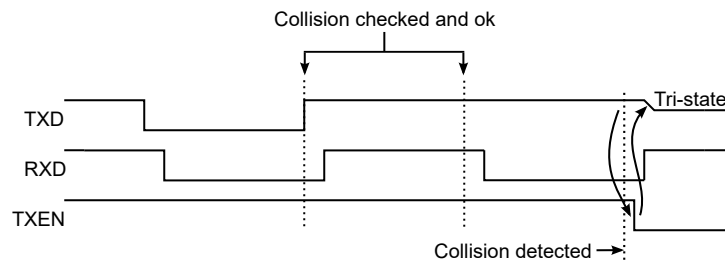
Collision detection is performed for each bit transmitted by comparing the received value with the transmit value, as shown in the figure below. While the transmitter is idle (no transmission in progress), characters can be received on RxD without triggering a collision.

**Figure 34-20. Collision Checking**



The next figure shows the conditions for a collision detection. In this case, the Start bit and the first Data bit are received with the same value as transmitted. The second received Data bit is found to be different than the transmitted bit at the detection point, which indicates a collision.

**Figure 34-21. Collision Detected**



When a collision is detected, the USART follows this sequence:

1. Abort the current transfer.
2. Flush the transmit buffer.
3. Disable transmitter (CTRLB.TXEN=0)
  - This is done after a synchronization delay. The CTRLB Synchronization Busy bit (SYNCBUSY.CTRLB) will be set until this is complete.
  - After disabling, the TxD pin will be tri-stated.
4. Set the Collision Detected bit (STATUS.COLL) along with the Error Interrupt Flag (INTFLAG.ERROR).
5. Set the Transmit Complete Interrupt Flag (INTFLAG.TXC), since the transmit buffer no longer contains data.

After a collision, software must manually enable the transmitter again before continuing, after assuring that the CTRLB Synchronization Busy bit (SYNCBUSY.CTRLB) is not set.

### 34.6.3.9 Loop-Back Mode

For Loop-Back mode, configure the Receive Data Pinout (CTRLA.RXPO) and Transmit Data Pinout (CTRLA.TXPO) to use the same data pins for transmit and receive. The loop-back is through the pad, so the signal is also available externally.

### 34.6.3.10 Start-of-Frame Detection

The USART start-of-frame detector can wake-up the CPU when it detects a Start bit. In Standby Sleep mode, the internal fast start-up oscillator must be selected as the GCLK\_SERCOMx\_CORE source.

When a 1-to-0 transition is detected on RxD, the 8 MHz Internal Oscillator is powered up and the USART clock is enabled. After start-up, the rest of the data frame can be received, provided that the baud rate is slow enough in relation to the fast start-up internal oscillator start-up time. Refer to the *Electrical Characteristics* chapters for details. The start-up time of this oscillator varies with supply voltage and temperature.

The USART start-of-frame detection works both in Asynchronous and Synchronous modes. It is enabled by writing '1' to the Start of Frame Detection Enable bit in the Control B register (CTRLB.SFDE).

If the Receive Start Interrupt Enable bit in the Interrupt Enable Set register (INTENSET.RXS) is set, the Receive Start interrupt is generated immediately when a start is detected.

When using start-of-frame detection without the Receive Start interrupt, start detection will force the 8 MHz internal oscillator and USART clock active while the frame is being received. In this case, the CPU will not wake up until the receive complete interrupt is generated.

### 34.6.3.11 Sample Adjustment

In Asynchronous mode (CTRLA.CMODE=0), three samples in the middle are used to determine the value based on majority voting. The three samples used for voting can be selected using the Sample Adjustment bit field in Control A register (CTRLA.SAMPA). When CTRLA.SAMPA=0, samples 7-8-9 are used for 16x oversampling, and samples 3-4-5 are used for 8x oversampling.

### 34.6.3.12 32-bit Extension

For better system bus utilization, 32-bit data receive and transmit can be enabled separately by writing to the Data 32-bit bit field in the Control C register (CTRLC.DATA32B). When enabled, writes and/or reads to the DATA register are 32 bit in size.

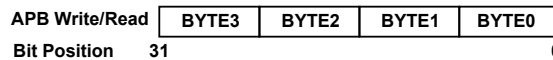
If frames are not multiples of 4 Bytes, the length counter (LENGTH.LEN) and length enable (LENGTH.LENEN) must be configured before data transfer begins, LENGTH.LEN must be enabled only when CTRLC.DATA32B is enabled.

# SAM D5x/E5x Family Data Sheet

## SERCOM USART - SERCOM Synchronous and Asyn...

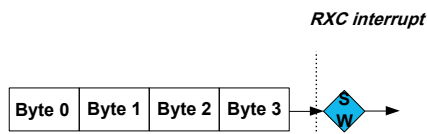
The figure below shows the order of transmit and receive when using 32-bit extension. Bytes are transmitted or received, and stored in order from 0 to 3. Only 8-bit and smaller character sizes are supported. If the character size is less than 8 bits, characters will still be 8-bit aligned within the 32-bit APB write or read. The unused bits within each byte will be zero for received data and unused for transmit data.

**Figure 34-22. 32-bit Extension Ordering**



A receive transaction using 32-bit extension is in the next figure. The Receive Complete flag (INTFLAG.RXC) is raised every four received Bytes. For transmit transactions, the Data Register Empty flag (INTFLAG.DRE) is raised instead of INTFLAG.RXC.

**Figure 34-23. 32-bit Extension Receive Operation**



### Data Length Configuration

When the Data Length Enable bit field in the Length register (LENGTH.LENEN) is written to 0x1 or 0x2, the Data Length bit (LENGTH.LEN) determines the number of characters to be transmitted or received from 1 to 255.

**Note:** There is one internal length counter that can be used for either transmit (LENGTH.LENEN=0x1) or receive (LENGTH.LENEN=0x2), but not for both simultaneously.

The LENGTH register must be written before the frame begins. If LENGTH.LEN is not a multiple of 4 Bytes, the final INTFLAG.RXC/DRE interrupt will be raised when the last byte is received/sent. The internal length counter is reset when LENGTH.LEN is reached or when LENGTH.LENEN is written to 0x0.

Writing the LENGTH register while a frame is in progress will produce unpredictable results. If LENGTH.LENEN is not set and a frame is not a multiple of 4 Bytes, the remainder may be lost. Attempting to use the length counter for transmit and receive at the same time will produce unpredictable results.

# SAM D5x/E5x Family Data Sheet

## SERCOM USART - SERCOM Synchronous and Asyn...

### 34.6.4 DMA, Interrupts and Events

**Table 34-4. Module Request for SERCOM USART**

Condition	Request		
	DMA	Interrupt	Event
Data Register Empty (DRE)	Yes (request cleared when data is written)	Yes	NA
Receive Complete (RXC)	Yes (request cleared when data is read)	Yes	
Transmit Complete (TXC)	NA	Yes	
Receive Start (RXS)	NA	Yes	
Clear to Send Input Change (CTSIC)	NA	Yes	
Receive Break (RXBRK)	NA	Yes	
Error (ERROR)	NA	Yes	

#### 34.6.4.1 DMA Operation

The USART generates the following DMA requests:

- Data received (RX): The request is set when data is available in the receive FIFO. The request is cleared when DATA is read.
- Data transmit (TX): The request is set when the transmit buffer (TX DATA) is empty. The request is cleared when DATA is written.

#### 34.6.4.2 Interrupts

The USART has the following interrupt sources. These are asynchronous interrupts, and can wake-up the device from any Sleep mode:

- Data Register Empty (DRE)
- Receive Complete (RXC)
- Transmit Complete (TXC)
- Receive Start (RXS)
- Clear to Send Input Change (CTSIC)
- Received Break (RXBRK)
- Error (ERROR)

Each interrupt source has its own Interrupt flag. The Interrupt flag in the Interrupt Flag Status and Clear register (INTFLAG) will be set when the Interrupt condition is met. Each interrupt can be individually enabled by writing '1' to the corresponding bit in the Interrupt Enable Set register (INTENSET), and disabled by writing '1' to the corresponding bit in the Interrupt Enable Clear register (INTENCLR).

An interrupt request is generated when the Interrupt flag is set and if the corresponding interrupt is enabled. The interrupt request remains active until either the Interrupt flag is cleared, the interrupt is disabled, or the USART is reset. For details on clearing Interrupt flags, refer to the INTFLAG register description.

The value of INTFLAG indicates which interrupt is executed. Note that interrupts must be globally enabled for interrupt requests. Refer to *Nested Vector Interrupt Controller* for details.

### Related Links

[10.2 Nested Vector Interrupt Controller](#)

#### 34.6.4.3 Events

Not applicable.

#### 34.6.5 Sleep Mode Operation

The behavior in Sleep mode is depending on the clock source and the Run In Standby bit in the Control A register (CTRLA.RUNSTDBY):

- Internal clocking, CTRLA.RUNSTDBY=1: GCLK\_SERCOMx\_CORE can be enabled in all Sleep modes. Any interrupt can wake-up the device.
- External clocking, CTRLA.RUNSTDBY=1: The Receive Complete interrupt(s) can wake-up the device.
- Internal clocking, CTRLA.RUNSTDBY=0: Internal clock will be disabled, after any ongoing transfer was completed. The Receive Complete interrupt(s) can wake-up the device.
- External clocking, CTRLA.RUNSTDBY=0: External clock will be disconnected, after any ongoing transfer was completed. All reception will be dropped.

#### 34.6.6 Synchronization

Due to asynchronicity between the main clock domain and the peripheral clock domains, some registers need to be synchronized when written or read.

The following bits are synchronized when written:

- Software Reset bit in the CTRLA register (CTRLA.SWRST)
- Enable bit in the CTRLA register (CTRLA.ENABLE)
- Receiver Enable bit in the CTRLB register (CTRLB.RXEN)
- Transmitter Enable bit in the Control B register (CTRLB.TXEN)

**Note:** CTRLB.RXEN is write-synchronized somewhat differently. See also [34.8.2 CTRLB](#) for details.

Required write synchronization is denoted by the "Write-Synchronized" property in the register description.

# SAM D5x/E5x Family Data Sheet

## SERCOM USART - SERCOM Synchronous and Asyn...

### 34.7 Register Summary

Offset	Name	Bit Pos.								
0x00	CTRLA	7:0	RUNSTDBY			MODE[2:0]			ENABLE	SWRST
		15:8	SAMPR[2:0]					RXINV	TXINV	IBON
		23:16	SAMPA[1:0]		RXPO[1:0]				TXPO[1:0]	
		31:24		DORD	CPOL	CMODE	FORM[3:0]			
0x04	CTRLB	7:0		SBMODE				CHSIZE[2:0]		
		15:8			PMODE			ENC	SFDE	COLDEN
		23:16							RXEN	TXEN
		31:24							LINCMD[1:0]	
0x08	CTRLC	7:0						GTIME[2:0]		
		15:8					HDRDLY[1:0]		BRKLEN[1:0]	
		23:16		MAXITER[2:0]					DSNACK	INACK
		31:24							DATA32B[1:0]	
0x0C	BAUD	7:0	BAUD[7:0]							
		15:8	BAUD[15:8]							
0x0E	RXPL	7:0	RXPL[7:0]							
0x0F ... 0x13	Reserved									
0x14	INTENCLR	7:0	ERROR		RXBRK	CTSIC	RXS	RXC	TXC	DRE
0x15	Reserved									
0x16	INTENSET	7:0	ERROR		RXBRK	CTSIC	RXS	RXC	TXC	DRE
0x17	Reserved									
0x18	INTFLAG	7:0	ERROR		RXBRK	CTSIC	RXS	RXC	TXC	DRE
0x19	Reserved									
0x1A	STATUS	7:0	ITER	TXE	COLL	ISF	CTS	BUFOVF	FERR	PERR
		15:8								
0x1C	SYNCBUSY	7:0				LENGTH	RXERRCNT	CTRLB	ENABLE	SWRST
		15:8								
		23:16								
		31:24								
0x20	RXERRCNT	7:0	RXERRCNT[7:0]							
0x21	Reserved									
0x22	LENGTH	7:0	LEN[7:0]							
		15:8							LENEN[1:0]	
0x24 ... 0x27	Reserved									
0x28	DATA	7:0	DATA[7:0]							
		15:8	DATA[15:8]							
		23:16	DATA[23:16]							
		31:24	DATA[31:24]							

# SAM D5x/E5x Family Data Sheet

## SERCOM USART - SERCOM Synchronous and Asyn...

.....continued

Offset	Name	Bit Pos.								
0x2C	Reserved									
...										
0x2F										
0x30	DBGCTRL	7:0								DBGSTOP

### 34.8 Register Description

Registers can be 8, 16, or 32 bits wide. Atomic 8-, 16-, and 32-bit accesses are supported. In addition, the 8-bit quarters and 16-bit halves of a 32-bit register, and the 8-bit halves of a 16-bit register can be accessed directly.

Some registers require synchronization when read and/or written. Synchronization is denoted by the "Read-Synchronized" and/or "Write-Synchronized" property in each individual register description.

Optional write protection by the Peripheral Access Controller (PAC) is denoted by the "PAC Write Protection" property in each individual register description.

Some registers are enable-protected, meaning they can only be written when the module is disabled. Enable protection is denoted by the "Enable-Protected" property in each individual register description.

# SAM D5x/E5x Family Data Sheet

## SERCOM USART - SERCOM Synchronous and Asyn...

### 34.8.1 Control A

**Name:** CTRLA  
**Offset:** 0x00  
**Reset:** 0x00000000  
**Property:** PAC Write-Protection, Enable-Protected

	Bit	31	30	29	28	27	26	25	24
			DORD	CPOL	CMODE	FORM[3:0]			
Access			R/W	R/W	R/W	R/W	R/W	R/W	R/W
Reset			0	0	0	0	0	0	0
	Bit	23	22	21	20	19	18	17	16
		SAMPA[1:0]		RXPO[1:0]				TXPO[1:0]	
Access		R/W	R/W	R/W	R/W			R/W	R/W
Reset		0	0	0	0			0	0
	Bit	15	14	13	12	11	10	9	8
		SAMPR[2:0]					RXINV	TXINV	IBON
Access		R/W	R/W	R/W			R/W	R/W	R/W
Reset		0	0	0			0	0	0
	Bit	7	6	5	4	3	2	1	0
		RUNSTDBY			MODE[2:0]		ENABLE	SWRST	
Access		R/W			R/W	R/W	R/W	R/W	R/W
Reset		0			0	0	0	0	0

#### Bit 30 – DORD Data Order

This bit selects the data order when a character is shifted out from the Data register. This bit is not synchronized.

Value	Description
0	MSB is transmitted first.
1	LSB is transmitted first.

#### Bit 29 – CPOL Clock Polarity

This bit selects the relationship between data output change and data input sampling in synchronous mode. This bit is not synchronized.

CPOL	TxD Change	RxD Sample
0x0	Rising XCK edge	Falling XCK edge
0x1	Falling XCK edge	Rising XCK edge

#### Bit 28 – CMODE Communication Mode

This bit selects asynchronous or synchronous communication. This bit is not synchronized.

Value	Description
0	Asynchronous communication.



# SAM D5x/E5x Family Data Sheet

## SERCOM USART - SERCOM Synchronous and Asyn...

Value	Description
1	Synchronous communication.

### Bits 27:24 – FORM[3:0] Frame Format

These bits define the frame format.

These bits are not synchronized.

FORM[3:0]	Description
0x0	USART frame
0x1	USART frame with parity
0x2	LIN Master - Break and sync generation. See LIN Command (CTRLB.LINCMD).
0x3	Reserved
0x4	Auto-baud (LIN Slave) - break detection and auto-baud.
0x5	Auto-baud - break detection and auto-baud with parity
0x6	Reserved
0x7	ISO 7816
0x8-0xF	Reserved

### Bits 23:22 – SAMPA[1:0] Sample Adjustment

These bits define the sample adjustment.

These bits are not synchronized.

SAMPA[1:0]	16x Over-sampling (CTRLA.SAMPR=0 or 1)	8x Over-sampling (CTRLA.SAMPR=2 or 3)
0x0	7-8-9	3-4-5
0x1	9-10-11	4-5-6
0x2	11-12-13	5-6-7
0x3	13-14-15	6-7-8

### Bits 21:20 – RXPO[1:0] Receive Data Pinout

These bits define the receive data (RxD) pin configuration.

These bits are not synchronized.

RXPO[1:0]	Name	Description
0x0	PAD[0]	SERCOM PAD[0] is used for data reception
0x1	PAD[1]	SERCOM PAD[1] is used for data reception
0x2	PAD[2]	SERCOM PAD[2] is used for data reception
0x3	PAD[3]	SERCOM PAD[3] is used for data reception

### Bits 17:16 – TXPO[1:0] Transmit Data Pinout

These bits define the transmit data (TxD) and XCK pin configurations.

This bit is not synchronized.

# SAM D5x/E5x Family Data Sheet

## SERCOM USART - SERCOM Synchronous and Asyn...

TXPO	TxD Pin Location	XCK Pin Location (When Applicable)	RTS/TE	CTS
0x0	SERCOM PAD[0]	SERCOM PAD[1]	N/A	N/A
0x1	Reserved			
0x2	SERCOM PAD[0]	N/A	SERCOM PAD[2]	SERCOM PAD[3]
0x3	SERCOM_PAD[0]	SERCOM_PAD[1]	SERCOM_PAD[2]	N/A

### Bits 15:13 – SAMPR[2:0] Sample Rate

These bits select the sample rate.

These bits are not synchronized.

SAMPR[2:0]	Description
0x0	16x over-sampling using arithmetic baud rate generation.
0x1	16x over-sampling using fractional baud rate generation.
0x2	8x over-sampling using arithmetic baud rate generation.
0x3	8x over-sampling using fractional baud rate generation.
0x4	3x over-sampling using arithmetic baud rate generation.
0x5-0x7	Reserved

### Bit 10 – RXINV Receive Data Invert

This bit controls whether the receive data (RxD) is inverted or not.

**Note:** Start, parity and stop bit(s) are unchanged. When enabled, parity is calculated on the inverted data.

Value	Description
0	RxD is not inverted.
1	RxD is inverted.

### Bit 9 – TXINV Transmit Data Invert

This bit controls whether the transmit data (TxD) is inverted or not.

**Note:** Start, parity and stop bit(s) are unchanged. When enabled, parity is calculated on the inverted data.

Value	Description
0	TxD is not inverted.
1	TxD is inverted.

### Bit 8 – IBON Immediate Buffer Overflow Notification

This bit controls when the buffer overflow status bit (STATUS.BUFOVF) is asserted when a buffer overflow occurs.

Value	Description
0	STATUS.BUFOVF is asserted when it occurs in the data stream.
1	STATUS.BUFOVF is asserted immediately upon buffer overflow.

# SAM D5x/E5x Family Data Sheet

## SERCOM USART - SERCOM Synchronous and Asyn...

### Bit 7 – RUNSTDBY Run In Standby

This bit defines the functionality in standby sleep mode.

This bit is not synchronized.

RUNSTDBY	External Clock	Internal Clock
0x0	External clock is disconnected when ongoing transfer is finished. All reception is dropped.	Generic clock is disabled when ongoing transfer is finished. The device will not wake up on Transfer Complete interrupt unless the appropriate ONDEMAND bits are set in the clocking chain.
0x1	Wake on Receive Complete interrupt.	Generic clock is enabled in all sleep modes. Any interrupt can wake up the device.

### Bits 4:2 – MODE[2:0] Operating Mode

These bits select the USART serial communication interface of the SERCOM.

These bits are not synchronized.

Value	Description
0x0	USART with external clock
0x1	USART with internal clock

### Bit 1 – ENABLE Enable

Due to synchronization, there is delay from writing CTRLA.ENABLE until the peripheral is enabled/disabled. The value written to CTRLA.ENABLE will read back immediately and the Enable Synchronization Busy bit in the Synchronization Busy register (SYNCBUSY.ENABLE) will be set. SYNCBUSY.ENABLE is cleared when the operation is complete.

This bit is not enable-protected.

Value	Description
0	The peripheral is disabled or being disabled.
1	The peripheral is enabled or being enabled.

### Bit 0 – SWRST Software Reset

Writing '0' to this bit has no effect.

Writing '1' to this bit resets all registers in the SERCOM, except DBGCTRL, to their initial state, and the SERCOM will be disabled.

Writing '1' to CTRLA.SWRST will always take precedence, meaning that all other writes in the same write-operation will be discarded. Any register write access during the ongoing reset will result in an APB error. Reading any register will return the reset value of the register.

Due to synchronization, there is a delay from writing CTRLA.SWRST until the reset is complete.

CTRLA.SWRST and SYNCBUSY.SWRST will both be cleared when the reset is complete.

This bit is not enable-protected.

Value	Description
0	There is no reset operation ongoing.
1	The reset operation is ongoing.

# SAM D5x/E5x Family Data Sheet

## SERCOM USART - SERCOM Synchronous and Asyn...

### 34.8.2 Control B

**Name:** CTRLB  
**Offset:** 0x04  
**Reset:** 0x00000000  
**Property:** PAC Write-Protection, Enable-Protected, Write-Synchronized

Bit	31	30	29	28	27	26	25	24
							LINCMD[1:0]	
Access							R/W	R/W
Reset							0	0
Bit	23	22	21	20	19	18	17	16
							RXEN	TXEN
Access							R/W	R/W
Reset							0	0
Bit	15	14	13	12	11	10	9	8
			PMODE			ENC	SFDE	COLDEN
Access			R/W			R/W	R/W	R/W
Reset			0			0	0	0
Bit	7	6	5	4	3	2	1	0
			SBMODE			CHSIZE[2:0]		
Access			R/W			R/W	R/W	R/W
Reset			0			0	0	0

#### Bits 25:24 – LINCMD[1:0] LIN Command

These bits define the LIN header transmission control. This field is only valid in LIN master mode (CTRLA.FORM= LIN Master).

These are strobe bits and will always read back as zero.

These bits are not enable-protected.

Value	Description
0x0	Normal USART transmission.
0x1	Break field is transmitted when DATA is written.
0x2	Break, sync and identifier are automatically transmitted when DATA is written with the identifier.
0x3	Reserved

#### Bit 17 – RXEN Receiver Enable

Writing '0' to this bit will disable the USART receiver. Disabling the receiver will flush the receive buffer and clear the FERR, PERR and BUFOVF bits in the STATUS register.

Writing '1' to CTRLB.RXEN when the USART is disabled will set CTRLB.RXEN immediately. When the USART is enabled, CTRLB.RXEN will be cleared, and SYNCBUSY.CTRLB will be set and remain set until the receiver is enabled. When the receiver is enabled, CTRLB.RXEN will read back as '1'.

Writing '1' to CTRLB.RXEN when the USART is enabled will set SYNCBUSY.CTRLB, which will remain set until the receiver is enabled, and CTRLB.RXEN will read back as '1'.

This bit is not enable-protected.

# SAM D5x/E5x Family Data Sheet

## SERCOM USART - SERCOM Synchronous and Asyn...

Value	Description
0	The receiver is disabled or being enabled.
1	The receiver is enabled or will be enabled when the USART is enabled.

### Bit 16 – TXEN Transmitter Enable

Writing '0' to this bit will disable the USART transmitter. Disabling the transmitter will not become effective until ongoing and pending transmissions are completed.

Writing '1' to CTRLB.TXEN when the USART is disabled will set CTRLB.TXEN immediately. When the USART is enabled, CTRLB.TXEN will be cleared, and SYNCBUSY.CTRLB will be set and remain set until the transmitter is enabled. When the transmitter is enabled, CTRLB.TXEN will read back as '1'.

Writing '1' to CTRLB.TXEN when the USART is enabled will set SYNCBUSY.CTRLB, which will remain set until the transmitter is enabled, and CTRLB.TXEN will read back as '1'.

This bit is not enable-protected.

Value	Description
0	The transmitter is disabled or being enabled.
1	The transmitter is enabled or will be enabled when the USART is enabled.

### Bit 13 – PMODE Parity Mode

This bit selects the type of parity used when parity is enabled (CTRLA.FORM is '1'). The transmitter will automatically generate and send the parity of the transmitted data bits within each frame. The receiver will generate a parity value for the incoming data and parity bit, compare it to the parity mode and, if a mismatch is detected, STATUS.PERR will be set.

This bit is not synchronized.

Value	Description
0	Even parity.
1	Odd parity.

### Bit 10 – ENC Encoding Format

This bit selects the data encoding format.

This bit is not synchronized.

Value	Description
0	Data is not encoded.
1	Data is IrDA encoded.

### Bit 9 – SFDE Start of Frame Detection Enable

This bit controls whether the start-of-frame detector will wake up the device when a start bit is detected on the RxD line.

This bit is not synchronized.

SFDE	INTENSET.RXS	INTENSET.RXC	Description
0	X	X	Start-of-frame detection disabled.
1	0	0	Reserved
1	0	1	Start-of-frame detection enabled. RXC wakes up the device from all sleep modes.
1	1	0	Start-of-frame detection enabled. RXS wakes up the device from all sleep modes.

# SAM D5x/E5x Family Data Sheet

## SERCOM USART - SERCOM Synchronous and Asyn...

.....continued

SFDE	INTENSET.RXS	INTENSET.RXC	Description
1	1	1	Start-of-frame detection enabled. Both RXC and RXS wake up the device from all sleep modes.

**Bit 8 – COLDEN** Collision Detection Enable

This bit enables collision detection.

This bit is not synchronized.

Value	Description
0	Collision detection is not enabled.
1	Collision detection is enabled.

**Bit 6 – SBMODE** Stop Bit Mode

This bit selects the number of stop bits transmitted.

This bit is not synchronized.

Value	Description
0	One stop bit.
1	Two stop bits.

**Bits 2:0 – CHSIZE[2:0]** Character Size

These bits select the number of bits in a character.

These bits are not synchronized.

CHSIZE[2:0]	Description
0x0	8 bits
0x1	9 bits
0x2-0x4	Reserved
0x5	5 bits
0x6	6 bits
0x7	7 bits

# SAM D5x/E5x Family Data Sheet

## SERCOM USART - SERCOM Synchronous and Asyn...

### 34.8.3 Control C

**Name:** CTRLC  
**Offset:** 0x08  
**Reset:** 0x00000000  
**Property:** PAC Write-Protection, Enable-Protected

	Bit	31	30	29	28	27	26	25	24	
								DATA32B[1:0]		
Access								R/W	R/W	
Reset								0	0	
	Bit	23	22	21	20	19	18	17	16	
								MAXITER[2:0]	DSNACK	INACK
Access		R/W		R/W		R/W		R/W	R/W	
Reset		0		0		0		0	0	
	Bit	15	14	13	12	11	10	9	8	
						HDRDLY[1:0]		BRKLEN[1:0]		
Access						R/W	R/W	R/W	R/W	
Reset						0	0	0	0	
	Bit	7	6	5	4	3	2	1	0	
								GTIME[2:0]		
Access								R/W	R/W	R/W
Reset								0	0	0

#### Bits 25:24 – DATA32B[1:0] Data 32 Bit

These bits configure 32-bit Extension for read and write transactions to the DATA register. When disabled, access is according to CTRLB.CHSIZE.

Value	Description
0x0	DATA reads (for received data) and writes (for transmit data) according to CTRLB.CHSIZE.
0x1	DATA reads according to CTRLB.CHSIZE. DATA writes using 32-bit Extension.
0x2	DATA reads using 32-bit Extension. DATA writes according to CTRLB.CHSIZE.
0x3	DATA reads and writes using 32-bit Extension.

#### Bits 22:20 – MAXITER[2:0] Maximum Iterations

These bits define the maximum number of retransmit iterations.

These bits also define the successive NACKs sent to the remote transmitter when CTRLC.DSNACK is set.

This field is only valid when using ISO7816 T=0 mode (CTRLA.MODE=0x7 and CTRLA.CMODE=0).

#### Bit 17 – DSNACK Disable Successive Not Acknowledge

This bit controls how many times NACK will be sent on parity error reception.

This bit is only valid in ISO7816 T=0 mode and when CTRLC.INACK=0.

# SAM D5x/E5x Family Data Sheet

## SERCOM USART - SERCOM Synchronous and Asyn...

Value	Description
0	NACK is sent on the ISO line for every parity error received.
1	Successive parity errors are counted up to the value specified in CTRLC.MAXITER. These parity errors generate a NACK on the ISO line. As soon as this value is reached, no additional NACK is sent on the ISO line.

### Bit 16 – INACK Inhibit Not Acknowledge

This bit controls whether a NACK is transmitted when a parity error is received.

This bit is only valid in ISO7816 T=0 mode.

Value	Description
0	NACK is transmitted when a parity error is received.
1	NACK is not transmitted when a parity error is received.

### Bits 11:10 – HDRDLY[1:0] LIN Master Header Delay

These bits define the delay between break and sync transmission in addition to the delay between the sync and identifier (ID) fields when in LIN master mode (CTRLA.FORM=0x2).

This field is only valid when using the LIN header command (CTRLB.LINCMD=0x2).

Value	Description
0x0	Delay between break and sync transmission is 1 bit time. Delay between sync and ID transmission is 1 bit time.
0x1	Delay between break and sync transmission is 4 bit time. Delay between sync and ID transmission is 4 bit time.
0x2	Delay between break and sync transmission is 8 bit time. Delay between sync and ID transmission is 4 bit time.
0x3	Delay between break and sync transmission is 14 bit time. Delay between sync and ID transmission is 4 bit time.

### Bits 9:8 – BRKLEN[1:0] LIN Master Break Length

These bits define the length of the break field transmitted when in LIN master mode (CTRLA.FORM=0x2).

Value	Description
0x0	Break field transmission is 13 bit times
0x1	Break field transmission is 17 bit times
0x2	Break field transmission is 21 bit times
0x3	Break field transmission is 26 bit times

### Bits 2:0 – GTIME[2:0] Guard Time

These bits define the guard time when using RS485 mode (CTRLA.FORM=0x0 or CTRLA.FORM=0x1, and CTRLA.TXPO=0x3) or ISO7816 mode (CTRLA.FORM=0x7).

For RS485 mode, the guard time is programmable from 0-7 bit times and defines the time that the transmit enable pin (TE) remains high after the last stop bit is transmitted and there is no remaining data to be transmitted.

For ISO7816 T=0 mode, the guard time is programmable from 2-9 bit times and defines the guard time between each transmitted byte.



# SAM D5x/E5x Family Data Sheet

## SERCOS USART - SERCOM Synchronous and Asyn...

### 34.8.4 Baud

**Name:** BAUD  
**Offset:** 0x0C  
**Reset:** 0x0000  
**Property:** Enable-Protected, PAC Write-Protection

	15	14	13	12	11	10	9	8
	BAUD[15:8]							
Access	R/W	R/W	R/W	R/W	R/W	R/W	R/W	R/W
Reset	0	0	0	0	0	0	0	0
	7	6	5	4	3	2	1	0
	BAUD[7:0]							
Access	R/W	R/W	R/W	R/W	R/W	R/W	R/W	R/W
Reset	0	0	0	0	0	0	0	0

**Bits 15:0 – BAUD[15:0] Baud Value**

Arithmetic Baud Rate Generation (`CTRLA.SAMPR[0]=0`):

These bits control the clock generation, as described in the SERCOM Baud Rate section.

If Fractional Baud Rate Generation (`CTRLA.SAMPR[0]=1`) bit positions 15 to 13 are replaced by FP[2:0] Fractional Part:

- **Bits 15:13 - FP[2:0]: Fractional Part**

These bits control the clock generation, as described in the *SERCOM Clock Generation – Baud-Rate Generator* section.

- **Bits 12:0 - BAUD[12:0]: Baud Value**

These bits control the clock generation, as described in the *SERCOM Clock Generation – Baud-Rate Generator* section.

**Related Links**

[33.6.2.3 Clock Generation – Baud-Rate Generator](#)

[33.6.2.3.1 Asynchronous Arithmetic Mode BAUD Value Selection](#)

# SAM D5x/E5x Family Data Sheet

## SERCOM USART - SERCOM Synchronous and Asyn...

### 34.8.5 Receive Pulse Length Register

**Name:** RXPL  
**Offset:** 0x0E  
**Reset:** 0x00  
**Property:** Enable-Protected, PAC Write-Protection

Bit	7	6	5	4	3	2	1	0
	RXPL[7:0]							
Access	R/W	R/W	R/W	R/W	R/W	R/W	R/W	R/W
Reset	0	0	0	0	0	0	0	0

**Bits 7:0 – RXPL[7:0] Receive Pulse Length**

When the encoding format is set to IrDA (CTRLB.ENC=1), these bits control the minimum pulse length that is required for a pulse to be accepted by the IrDA receiver with regards to the serial engine clock period  $SE_{per}$ .

$$PULSE \geq (RXPL + 2) \cdot SE_{per}$$

# SAM D5x/E5x Family Data Sheet

## SERCOM USART - SERCOM Synchronous and Asyn...

### 34.8.6 Interrupt Enable Clear

**Name:** INTENCLR  
**Offset:** 0x14  
**Reset:** 0x00  
**Property:** PAC Write-Protection

This register allows the user to disable an interrupt without doing a read-modify-write operation. Changes in this register will also be reflected in the Interrupt Enable Set register (INTENSET).

Bit	7	6	5	4	3	2	1	0
	ERROR		RXBRK	CTSIC	RXS	RXC	TXC	DRE
Access	R/W		R/W	R/W	R/W	R/W	R/W	R/W
Reset	0		0	0	0	0	0	0

#### Bit 7 – ERROR Error Interrupt Enable

Writing '0' to this bit has no effect.

Writing '1' to this bit will clear the Error Interrupt Enable bit, which disables the Error interrupt.

Value	Description
0	Error interrupt is disabled.
1	Error interrupt is enabled.

#### Bit 5 – RXBRK Receive Break Interrupt Enable

Writing '0' to this bit has no effect.

Writing '1' to this bit will clear the Receive Break Interrupt Enable bit, which disables the Receive Break interrupt.

Value	Description
0	Receive Break interrupt is disabled.
1	Receive Break interrupt is enabled.

#### Bit 4 – CTSIC Clear to Send Input Change Interrupt Enable

Writing '0' to this bit has no effect.

Writing '1' to this bit will clear the Clear To Send Input Change Interrupt Enable bit, which disables the Clear To Send Input Change interrupt.

Value	Description
0	Clear To Send Input Change interrupt is disabled.
1	Clear To Send Input Change interrupt is enabled.

#### Bit 3 – RXS Receive Start Interrupt Enable

Writing '0' to this bit has no effect.

Writing '1' to this bit will clear the Receive Start Interrupt Enable bit, which disables the Receive Start interrupt.

Value	Description
0	Receive Start interrupt is disabled.
1	Receive Start interrupt is enabled.

#### Bit 2 – RXC Receive Complete Interrupt Enable

Writing '0' to this bit has no effect.

Writing '1' to this bit will clear the Receive Complete Interrupt Enable bit, which disables the Receive Complete interrupt.

# SAM D5x/E5x Family Data Sheet

## SERCOM USART - SERCOM Synchronous and Asyn...

Value	Description
0	Receive Complete interrupt is disabled.
1	Receive Complete interrupt is enabled.

### Bit 1 – TXC Transmit Complete Interrupt Enable

Writing '0' to this bit has no effect.

Writing '1' to this bit will clear the Transmit Complete Interrupt Enable bit, which disables the Receive Complete interrupt.

Value	Description
0	Transmit Complete interrupt is disabled.
1	Transmit Complete interrupt is enabled.

### Bit 0 – DRE Data Register Empty Interrupt Enable

Writing '0' to this bit has no effect.

Writing '1' to this bit will clear the Data Register Empty Interrupt Enable bit, which disables the Data Register Empty interrupt.

Value	Description
0	Data Register Empty interrupt is disabled.
1	Data Register Empty interrupt is enabled.

# SAM D5x/E5x Family Data Sheet

## SERCOM USART - SERCOM Synchronous and Asyn...

### 34.8.7 Interrupt Enable Set

**Name:** INTENSET  
**Offset:** 0x16  
**Reset:** 0x00  
**Property:** PAC Write-Protection

This register allows the user to disable an interrupt without doing a read-modify-write operation. Changes in this register will also be reflected in the Interrupt Enable Clear register (INTENCLR).

Bit	7	6	5	4	3	2	1	0
	ERROR		RXBRK	CTSIC	RXS	RXC	TXC	DRE
Access	R/W		R/W	R/W	R/W	R/W	R/W	R/W
Reset	0		0	0	0	0	0	0

#### Bit 7 – ERROR Error Interrupt Enable

Writing '0' to this bit has no effect.

Writing '1' to this bit will set the Error Interrupt Enable bit, which enables the Error interrupt.

Value	Description
0	Error interrupt is disabled.
1	Error interrupt is enabled.

#### Bit 5 – RXBRK Receive Break Interrupt Enable

Writing '0' to this bit has no effect.

Writing '1' to this bit will set the Receive Break Interrupt Enable bit, which enables the Receive Break interrupt.

Value	Description
0	Receive Break interrupt is disabled.
1	Receive Break interrupt is enabled.

#### Bit 4 – CTSIC Clear to Send Input Change Interrupt Enable

Writing '0' to this bit has no effect.

Writing '1' to this bit will set the Clear To Send Input Change Interrupt Enable bit, which enables the Clear To Send Input Change interrupt.

Value	Description
0	Clear To Send Input Change interrupt is disabled.
1	Clear To Send Input Change interrupt is enabled.

#### Bit 3 – RXS Receive Start Interrupt Enable

Writing '0' to this bit has no effect.

Writing '1' to this bit will set the Receive Start Interrupt Enable bit, which enables the Receive Start interrupt.

Value	Description
0	Receive Start interrupt is disabled.
1	Receive Start interrupt is enabled.

#### Bit 2 – RXC Receive Complete Interrupt Enable

Writing '0' to this bit has no effect.

Writing '1' to this bit will set the Receive Complete Interrupt Enable bit, which enables the Receive Complete interrupt.

# SAM D5x/E5x Family Data Sheet

## SERCOM USART - SERCOM Synchronous and Asyn...

Value	Description
0	Receive Complete interrupt is disabled.
1	Receive Complete interrupt is enabled.

### Bit 1 – TXC Transmit Complete Interrupt Enable

Writing '0' to this bit has no effect.

Writing '1' to this bit will set the Transmit Complete Interrupt Enable bit, which enables the Transmit Complete interrupt.

Value	Description
0	Transmit Complete interrupt is disabled.
1	Transmit Complete interrupt is enabled.

### Bit 0 – DRE Data Register Empty Interrupt Enable

Writing '0' to this bit has no effect.

Writing '1' to this bit will set the Data Register Empty Interrupt Enable bit, which enables the Data Register Empty interrupt.

Value	Description
0	Data Register Empty interrupt is disabled.
1	Data Register Empty interrupt is enabled.

# SAM D5x/E5x Family Data Sheet

## SERCOM USART - SERCOM Synchronous and Asyn...

### 34.8.8 Interrupt Flag Status and Clear

**Name:** INTFLAG  
**Offset:** 0x18  
**Reset:** 0x00  
**Property:** -

Bit	7	6	5	4	3	2	1	0
	ERROR		RXBRK	CTSIC	RXS	RXC	TXC	DRE
Access	R/W		R/W	R/W	R/W	R	R/W	R
Reset	0		0	0	0	0	0	0

#### Bit 7 – ERROR Error

This flag is cleared by writing '1' to it.

This bit is set when any error is detected. Errors that will set this flag have corresponding status flags in the STATUS register. Errors that will set this flag are COLL, ISF, BUFOVF, FERR, and PERR. Writing '0' to this bit has no effect.

Writing '1' to this bit will clear the flag.

#### Bit 5 – RXBRK Receive Break

This flag is cleared by writing '1' to it.

This flag is set when auto-baud is enabled (CTRLA.FORM) and a break character is received.

Writing '0' to this bit has no effect.

Writing '1' to this bit will clear the flag.

#### Bit 4 – CTSIC Clear to Send Input Change

This flag is cleared by writing a '1' to it.

This flag is set when a change is detected on the CTS pin.

Writing '0' to this bit has no effect.

Writing '1' to this bit will clear the flag.

#### Bit 3 – RXS Receive Start

This flag is cleared by writing '1' to it.

This flag is set when a Start condition is detected on the RxD line and start-of-frame detection is enabled (CTRLB.SFDE is '1').

Writing '0' to this bit has no effect.

Writing '1' to this bit will clear the Receive Start Interrupt flag.

#### Bit 2 – RXC Receive Complete

This flag is cleared by reading the Data register (DATA) or by disabling the receiver.

This flag is set when there are unread data in DATA.

Writing '0' to this bit has no effect.

Writing '1' to this bit has no effect.

#### Bit 1 – TXC Transmit Complete

This flag is cleared by writing '1' to it or by writing new data to DATA.

This flag is set when the entire frame in the Transmit Shift register has been shifted out and there are no new data in DATA.

Writing '0' to this bit has no effect.

# SAM D5x/E5x Family Data Sheet

## SERCOM USART - SERCOM Synchronous and Asyn...

---

Writing '1' to this bit will clear the flag.

**Bit 0 – DRE** Data Register Empty

This flag is cleared by writing new data to DATA.

This flag is set when DATA is empty and ready to be written.

Writing '0' to this bit has no effect.

Writing '1' to this bit has no effect.



# SAM D5x/E5x Family Data Sheet

## SERCOM USART - SERCOM Synchronous and Asyn...

### 34.8.9 Status

**Name:** STATUS  
**Offset:** 0x1A  
**Reset:** 0x0000  
**Property:** -

Bit	15	14	13	12	11	10	9	8
Access								
Reset								
Bit	7	6	5	4	3	2	1	0
	ITER	TXE	COLL	ISF	CTS	BUFOVF	FERR	PERR
Access	R/W	R/W	R/W	R/W	R	R/W	R/W	R/W
Reset	0	0	0	0	0	0	0	0

**Bit 7 – ITER** Maximum Number of Repetitions Reached

This bit is set when the maximum number of NACK repetitions or retransmissions is met in ISO7816 T=0 mode.

Writing '0' to this bit has no effect.

Writing '1' to this bit will clear it.

**Bit 6 – TXE** Transmitter Empty

When CTRLA.FORM is set to LIN Master mode, this bit is set when any ongoing transmission is complete and TxDATA is empty.

When CTRLA.FORM is not set to LIN Master mode, this bit will always read back as zero.

Writing '0' to this bit has no effect.

Writing '1' to this bit will clear it.

**Bit 5 – COLL** Collision Detected

This bit is cleared by writing '1' to the bit or by disabling the receiver.

This bit is set when collision detection is enabled (CTRLB.COLDEN) and a collision is detected.

Writing '0' to this bit has no effect.

Writing '1' to this bit will clear it.

**Bit 4 – ISF** Inconsistent Sync Field

This bit is cleared by writing '1' to the bit or by disabling the receiver.

This bit is set when the frame format is set to auto-baud (CTRLA.FORM) and a sync field not equal to 0x55 is received.

Writing '0' to this bit has no effect.

Writing '1' to this bit will clear it.

**Bit 3 – CTS** Clear to Send

This bit indicates the current level of the CTS pin when flow control is enabled (CTRLA.TXPO).

Writing '0' to this bit has no effect.

Writing '1' to this bit has no effect.

# SAM D5x/E5x Family Data Sheet

## SERCOM USART - SERCOM Synchronous and Asyn...

---

### **Bit 2 – BUFOVF** Buffer Overflow

Reading this bit before reading the Data register will indicate the error status of the next character to be read.

This bit is cleared by writing '1' to the bit or by disabling the receiver.

This bit is set when a buffer overflow condition is detected. A buffer overflow occurs when the receive buffer is full, there is a new character waiting in the receive shift register and a new start bit is detected. Writing '0' to this bit has no effect.

Writing '1' to this bit will clear it.

### **Bit 1 – FERR** Frame Error

Reading this bit before reading the Data register will indicate the error status of the next character to be read.

This bit is cleared by writing '1' to the bit or by disabling the receiver.

This bit is set if the received character had a frame error, i.e., when the first stop bit is zero.

Writing '0' to this bit has no effect.

Writing '1' to this bit will clear it.

### **Bit 0 – PERR** Parity Error

Reading this bit before reading the Data register will indicate the error status of the next character to be read.

This bit is cleared by writing '1' to the bit or by disabling the receiver.

This bit is set if parity checking is enabled (CTRLA.FORM is 0x1, 0x5, or 0x7) and a parity error is detected.

Writing '0' to this bit has no effect.

Writing '1' to this bit will clear it.

# SAM D5x/E5x Family Data Sheet

## SERCOM USART - SERCOM Synchronous and Asyn...

### 34.8.10 Synchronization Busy

**Name:** SYNCBUSY  
**Offset:** 0x1C  
**Reset:** 0x00000000  
**Property:** -

	31		30		29		28		27		26		25		24		
Access																	
Reset																	
	23		22		21		20		19		18		17		16		
Access																	
Reset																	
	15		14		13		12		11		10		9		8		
Access																	
Reset																	
	7		6		5		4		3		2		1		0		
Access							LENGTH			RXERRCNT			CTRLB			ENABLE	SWRST
Reset							R			R			R			R	R
							0			0			0			0	0

#### Bit 4 – LENGTH LENGTH Synchronization Busy

Writing to the LENGTH register requires synchronization. When writing to LENGTH, SYNCBUSY.LENGTH will be set until synchronization is complete. If the LENGTH register is written to while SYNCBUSY.LENGTH is asserted, an APB error is generated.

Value	Description
0	LENGTH synchronization is not busy.
1	LENGTH synchronization is busy.

#### Bit 3 – RXERRCNT Receive Error Count Synchronization Busy

The RXERRCNT register is automatically synchronized to the APB domain upon error. When returning from sleep, this bit will be raised until the new value is available to be read.

Value	Description
0	RXERRCNT synchronization is not busy.
1	RXERRCNT synchronization is busy.

#### Bit 2 – CTRLB CTRLB Synchronization Busy

Writing to the CTRLB register when the SERCOM is enabled requires synchronization. When writing to CTRLB the SYNCBUSY.CTRLB bit will be set until synchronization is complete. If CTRLB is written while SYNCBUSY.CTRLB is asserted, an APB error will be generated.

Value	Description
0	CTRLB synchronization is not busy.
1	CTRLB synchronization is busy.

# SAM D5x/E5x Family Data Sheet

## SERCOM USART - SERCOM Synchronous and Asyn...

---

**Bit 1 – ENABLE** SERCOM Enable Synchronization Busy

Enabling and disabling the SERCOM (CTRLA.ENABLE) requires synchronization. When written, the SYNCBUSY.ENABLE bit will be set until synchronization is complete.

Value	Description
0	Enable synchronization is not busy.
1	Enable synchronization is busy.

**Bit 0 – SWRST** Software Reset Synchronization Busy

Resetting the SERCOM (CTRLA.SWRST) requires synchronization. When written, the SYNCBUSY.SWRST bit will be set until synchronization is complete.

Value	Description
0	SWRST synchronization is not busy.
1	SWRST synchronization is busy.

# SAM D5x/E5x Family Data Sheet

## SERCOM USART - SERCOM Synchronous and Asyn...

### 34.8.11 Receive Error Count

**Name:** RXERRCNT  
**Offset:** 0x20  
**Reset:** 0x00  
**Property:** Read-Synchronized

Bit	7	6	5	4	3	2	1	0
	RXERRCNT[7:0]							
Access	R	R	R	R	R	R	R	R
Reset	0	0	0	0	0	0	0	0

#### Bits 7:0 – RXERRCNT[7:0] Receive Error Count

This register records the total number of parity errors and NACK errors combined in ISO7816 mode (CTRLA.FORM=0x7).

This register is automatically cleared on read.

# SAM D5x/E5x Family Data Sheet

## SERCOM USART - SERCOM Synchronous and Asyn...

### 34.8.12 Length

**Name:** LENGTH  
**Offset:** 0x22  
**Reset:** 0x00  
**Property:** PAC Write-Protection, Write-Synchronized

	Bit	15	14	13	12	11	10	9	8
								LENEN[1:0]	
Access								R/W	R/W
Reset								0	0
	Bit	7	6	5	4	3	2	1	0
		LEN[7:0]							
Access		R/W	R/W	R/W	R/W	R/W	R/W	R/W	R/W
Reset		0	0	0	0	0	0	0	0

#### Bits 9:8 – LENEN[1:0] Data Length Enable

In 32-bit Extension mode, this bit field configures the length counter either for transmit or receive transactions.

Value	Description
0x0	Length counter disabled
0x1	Length counter enabled for transmit
0x2	Length counter enabled for receive
0x3	Reserved

#### Bits 7:0 – LEN[7:0] Data Length

In 32-bit Extension mode, this bit field configures the data length after which the flags INTFLAG.RXC or INTFLAG.DRE are raised.

Value	Description
0x00	Reserved if LENEN=0x1 or LENEN=0x2
0x01-0xFF	Data Length

# SAM D5x/E5x Family Data Sheet

## SERCOM USART - SERCOM Synchronous and Asyn...

### 34.8.13 Data

**Name:** DATA  
**Offset:** 0x28  
**Reset:** 0x0000  
**Property:** -

	Bit	31	30	29	28	27	26	25	24
		DATA[31:24]							
Access		R/W	R/W	R/W	R/W	R/W	R/W	R/W	R/W
Reset		0	0	0	0	0	0	0	0
	Bit	23	22	21	20	19	18	17	16
		DATA[23:16]							
Access		R/W	R/W	R/W	R/W	R/W	R/W	R/W	R/W
Reset		0	0	0	0	0	0	0	0
	Bit	15	14	13	12	11	10	9	8
		DATA[15:8]							
Access		R/W	R/W	R/W	R/W	R/W	R/W	R/W	R/W
Reset		0	0	0	0	0	0	0	0
	Bit	7	6	5	4	3	2	1	0
		DATA[7:0]							
Access		R/W	R/W	R/W	R/W	R/W	R/W	R/W	R/W
Reset		0	0	0	0	0	0	0	0

#### Bits 31:0 – DATA[31:0] Data

Reading these bits will return the contents of the Receive Data register. The register should be read only when the Receive Complete Interrupt Flag bit in the Interrupt Flag Status and Clear register (INTFLAG.RXC) is set. The status bits in STATUS should be read before reading the DATA value in order to get any corresponding error.

Writing these bits will write the Transmit Data register. This register should be written only when the Data Register Empty Interrupt Flag bit in the Interrupt Flag Status and Clear register (INTFLAG.DRE) is set. Reads and writes are 32-bit or CTLB.CHSIZE based on the CTRLC.DATA32B setting.

# SAM D5x/E5x Family Data Sheet

## SERCOM USART - SERCOM Synchronous and Asyn...

### 34.8.14 Debug Control

**Name:** DBGCTRL  
**Offset:** 0x30  
**Reset:** 0x00  
**Property:** PAC Write-Protection

Bit	7	6	5	4	3	2	1	0
								DBGSTOP
Access								R/W
Reset								0

#### Bit 0 – DBGSTOP Debug Stop Mode

This bit controls the baud-rate generator functionality when the CPU is halted by an external debugger.

Value	Description
0	The baud-rate generator continues normal operation when the CPU is halted by an external debugger.
1	The baud-rate generator is halted when the CPU is halted by an external debugger.



## 35. SERCOM SPI – SERCOM Serial Peripheral Interface

### 35.1 Overview

The Serial Peripheral Interface (SPI) is one of the available modes in the Serial Communication Interface (SERCOM).

The SPI uses the SERCOM transmitter and receiver configured as shown in [35.3 Block Diagram](#). Each side, master and slave, depicts a separate SPI containing a Shift register, a transmit buffer and a two-level receive buffer. In addition, the SPI master uses the SERCOM baud-rate generator, while the SPI slave can use the SERCOM address match logic. Labels in capital letters are synchronous to CLK\_SERCOMx\_APB and accessible by the CPU, while labels in lowercase letters are synchronous to the SCK clock.

#### Related Links

[33. SERCOM – Serial Communication Interface](#)

### 35.2 Features

SERCOM SPI includes the following features:

- Full-duplex, four-wire interface (MISO, MOSI, SCK,  $\overline{SS}$ )
- One-level transmit buffer, two-level receive buffer
- Supports all four SPI modes of operation
- Single data direction operation allows alternate function on MISO or MOSI pin
- Selectable LSB- or MSB-first data transfer
- Can be used with DMA
- 32-bit Extension for better system bus utilization
- Master operation:
  - Serial clock speed,  $f_{SCK}=1/t_{SCK}^{(1)}$
  - 8-bit clock generator
  - Hardware controlled  $\overline{SS}$
  - Optional inter-character spacing
- Slave Operation:
  - Serial clock speed,  $f_{SCK}=1/t_{SSCK}^{(1)}$
  - Optional 8-bit address match operation
  - Operation in all sleep modes
  - Wake on  $\overline{SS}$  transition

1. For  $t_{SCK}$  and  $t_{SSCK}$  values, refer to SPI Timing Characteristics.

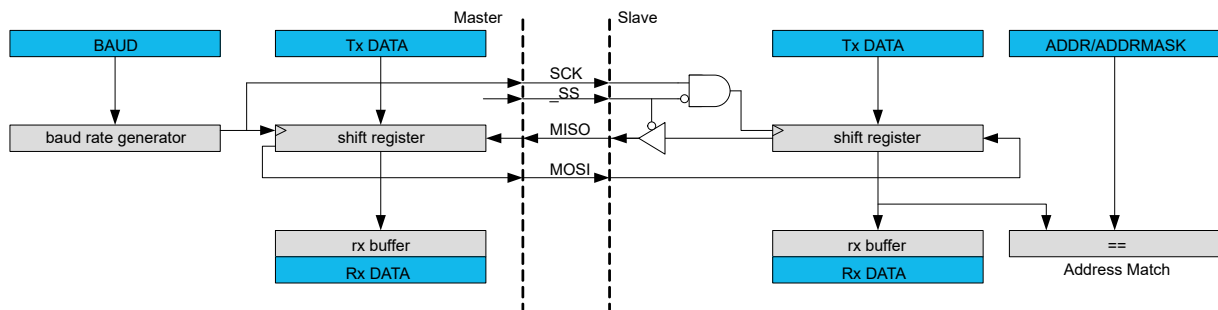
#### Related Links

[33. SERCOM – Serial Communication Interface](#)

[33.2 Features](#)

### 35.3 Block Diagram

Figure 35-1. Full-Duplex SPI Master Slave Interconnection



### 35.4 Signal Description

Table 35-1. SERCOM SPI Signals

Signal Name	Type	Description
PAD[3:0]	Digital I/O	General SERCOM pins

One signal can be mapped to one of several pins.

#### Related Links

[6. I/O Multiplexing and Considerations](#)

### 35.5 Product Dependencies

In order to use this peripheral, other parts of the system must be configured correctly, as described below.

#### 35.5.1 I/O Lines

In order to use the SERCOM's I/O lines, the I/O pins must be configured using the IO Pin Controller (PORT).

When the SERCOM is configured for SPI operation, the SERCOM controls the direction and value of the I/O pins according to the table below. Both PORT Control bits PINCFGn.PULLEN and PINCFGn.DRVSTR are still effective. If the receiver is disabled, the data input pin can be used for other purposes. In Master mode, the Slave Select line ( $\overline{SS}$ ) is hardware controlled when the Master Slave Select Enable bit in the Control B register (CTRLB.MSSEN) is '1'.

Table 35-2. SPI Pin Configuration

Pin	Master SPI	Slave SPI
MOSI	Output	Input
MISO	Input	Output
SCK	Output	Input
$\overline{SS}$	Output (CTRLB.MSSEN=1)	Input

# SAM D5x/E5x Family Data Sheet

## SERCOM SPI – SERCOM Serial Peripheral Interface

---

The combined configuration of PORT, the Data In Pinout and the Data Out Pinout bit groups in the Control A register (CTRLA.DIPO and CTRLA.DOPO) define the physical position of the SPI signals in the table above.

### Related Links

[32. PORT - I/O Pin Controller](#)

### 35.5.2 Power Management

This peripheral can continue to operate in any Sleep mode where its source clock is running. The interrupts can wake-up the device from Sleep modes.

### Related Links

[18. PM – Power Manager](#)

### 35.5.3 Clocks

The SERCOM bus clock (CLK\_SERCOMx\_APB) can be enabled and disabled in the Main Clock Controller. Refer to *Peripheral Clock Masking* for details and default status of this clock.

A generic clock (GCLK\_SERCOMx\_CORE) is required to clock the SPI. This clock must be configured and enabled in the Generic Clock Controller before using the SPI.

This generic clock is asynchronous to the bus clock (CLK\_SERCOMx\_APB). Therefore, writes to certain registers will require synchronization to the clock domains.

### Related Links

[14. GCLK - Generic Clock Controller](#)

[15.6.2.6 Peripheral Clock Masking](#)

[35.6.6 Synchronization](#)

### 35.5.4 DMA

The DMA request lines are connected to the DMA Controller (DMAC). In order to use DMA requests with this peripheral the DMAC must be configured first. Refer to *DMAC – Direct Memory Access Controller* for details.

### Related Links

[22. DMAC – Direct Memory Access Controller](#)

### 35.5.5 Interrupts

The interrupt request line is connected to the Interrupt Controller. In order to use interrupt requests of this peripheral, the Interrupt Controller (NVIC) must be configured first. Refer to *Nested Vector Interrupt Controller* for details.

### Related Links

[10.2 Nested Vector Interrupt Controller](#)

### 35.5.6 Events

Not applicable.

### 35.5.7 Debug Operation

When the CPU is halted in Debug mode, this peripheral will continue normal operation. If the peripheral is configured to require periodical service by the CPU through interrupts or similar, improper operation or data loss may result during debugging. This peripheral can be forced to halt operation during debugging - refer to the Debug Control (DBGCTRL) register for details.

### 35.5.8 Register Access Protection

Registers with write access can be write-protected optionally by the Peripheral Access Controller (PAC).

PAC write protection is not available for the following registers:

- Interrupt Flag Clear and Status register (INTFLAG)
- Status register (STATUS)
- Data register (DATA)

Optional PAC write protection is denoted by the "PAC Write-Protection" property in each individual register description.

Write-protection does not apply to accesses through an external debugger.

#### Related Links

[27. PAC - Peripheral Access Controller](#)

### 35.5.9 Analog Connections

Not applicable.

## 35.6 Functional Description

### 35.6.1 Principle of Operation

The SPI is a high-speed synchronous data transfer interface. It allows high-speed communication between the device and peripheral devices.

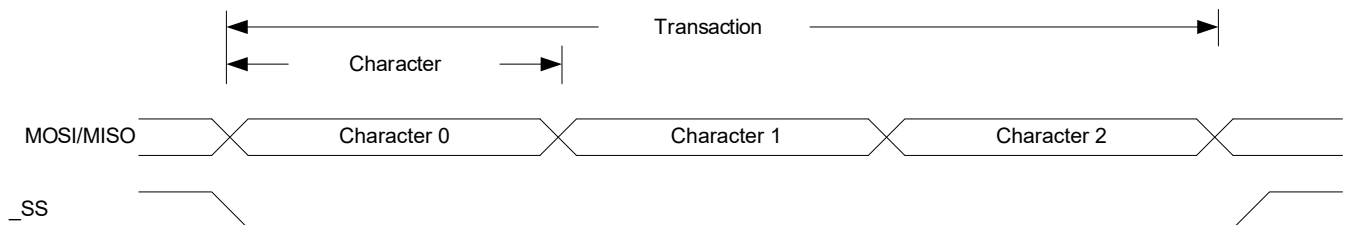
The SPI can operate as master or slave. As master, the SPI initiates and controls all data transactions. The SPI is single buffered for transmitting and double buffered for receiving.

When transmitting data, the Data register can be loaded with the next character to be transmitted during the current transmission.

When receiving, the data is transferred to the two-level receive buffer, and the receiver is ready for a new character.

The SPI transaction format is shown in [SPI Transaction Format](#). Each transaction can contain one or more characters. The character size is configurable, and can be either 8 or 9 bits.

**Figure 35-2. SPI Transaction Format**



The SPI master must pull the slave select line ( $\overline{SS}$ ) of the desired slave low to initiate a transaction. The master and slave prepare data to send via their respective Shift registers, and the master generates the serial clock on the SCK line.

Data are always shifted from master to slave on the Master Output Slave Input line (MOSI); data is shifted from slave to master on the Master Input Slave Output line (MISO).

Each time character is shifted out from the master, a character will be shifted out from the slave simultaneously. To signal the end of a transaction, the master will pull the  $\overline{SS}$  line high

# SAM D5x/E5x Family Data Sheet

## SERCOM SPI – SERCOM Serial Peripheral Interface

---

### 35.6.2 Basic Operation

#### 35.6.2.1 Initialization

The following registers are enable-protected, meaning that they can only be written when the SPI is disabled (CTRLA.ENABLE=0):

- Control A register (CTRLA), except Enable (CTRLA.ENABLE) and Software Reset (CTRLA.SWRST)
- Control B register (CTRLB), except Receiver Enable (CTRLB.RXEN)
- Baud register (BAUD)
- Address register (ADDR)

When the SPI is enabled or is being enabled (CTRLA.ENABLE=1), any writing to these registers will be discarded.

When the SPI is being disabled, writing to these registers will be completed after the disabling.

Enable-protection is denoted by the Enable-Protection property in the register description.

Initialize the SPI by following these steps:

1. Select SPI mode in master/slave operation in the Operating Mode bit group in the CTRLA register (CTRLA.MODE= 0x2 or 0x3 ).
2. Select Transfer mode for the Clock Polarity bit and the Clock Phase bit in the CTRLA register (CTRLA.CPOL and CTRLA.CPHA) if desired.
3. Select the Frame Format value in the CTRLA register (CTRLA.FORM).
4. Configure the Data In Pinout field in the Control A register (CTRLA.DIPO) for SERCOM pads of the receiver.
5. Configure the Data Out Pinout bit group in the Control A register (CTRLA.DOPO) for SERCOM pads of the transmitter.
6. Select the Character Size value in the CTRLB register (CTRLB.CHSIZE).
7. Write the Data Order bit in the CTRLA register (CTRLA.DORD) for data direction.
8. If the SPI is used in Master mode:
  - 8.1. Select the desired baud rate by writing to the Baud register (BAUD).
  - 8.2. If Hardware SS control is required, write '1' to the Master Slave Select Enable bit in CTRLB register (CTRLB.MSSEN).
9. Enable the receiver by writing the Receiver Enable bit in the CTRLB register (CTRLB.RXEN=1).

#### 35.6.2.2 Enabling, Disabling, and Resetting

This peripheral is enabled by writing '1' to the Enable bit in the Control A register (CTRLA.ENABLE), and disabled by writing '0' to it.

Writing '1' to the Software Reset bit in the Control A register (CTRLA.SWRST) will reset all registers of this peripheral to their initial states, except the DBGCTRL register, and the peripheral is disabled.

Refer to the CTRLA register description for details.

#### 35.6.2.3 Clock Generation

In the SPI master operation (CTRLA.MODE=0x3), the serial clock (SCK) is generated internally by the SERCOM Baud Rate Generator (BRG).

In SPI mode, the BRG is set to Synchronous mode. The 8-bit Baud register (BAUD) value is used for generating SCK and clocking the Shift register. Refer to *Clock Generation – Baud-Rate Generator* for more details.

# SAM D5x/E5x Family Data Sheet

## SERCOM SPI – SERCOM Serial Peripheral Interface

In SPI slave operation (CTRLA.MODE is 0x2), the clock is provided by an external master on the SCK pin. This clock is used to clock the SPI Shift register.

### Related Links

[33.6.2.3 Clock Generation – Baud-Rate Generator](#)

#### 35.6.2.4 Data Register

The SPI Transmit Data register (TxDATA) and SPI Receive Data register (RxDATA) share the same I/O address, referred to as the SPI Data register (DATA). Writing DATA register will update the Transmit Data register. Reading the DATA register will return the contents of the Receive Data register.

#### 35.6.2.5 SPI Transfer Modes

There are four combinations of SCK phase and polarity to transfer serial data. The SPI Data Transfer modes are shown in [SPI Transfer Modes \(Table\)](#) and [SPI Transfer Modes \(Figure\)](#).

SCK phase is configured by the Clock Phase bit in the CTRLA register (CTRLA.CPHA). SCK polarity is programmed by the Clock Polarity bit in the CTRLA register (CTRLA.CPOL). Data bits are shifted out and latched in on opposite edges of the SCK signal. This ensures sufficient time for the data signals to stabilize.

**Table 35-3. SPI Transfer Modes**

Mode	CPOL	CPHA	Leading Edge	Trailing Edge
0	0	0	Rising, sample	Falling, setup
1	0	1	Rising, setup	Falling, sample
2	1	0	Falling, sample	Rising, setup
3	1	1	Falling, setup	Rising, sample

### Note:

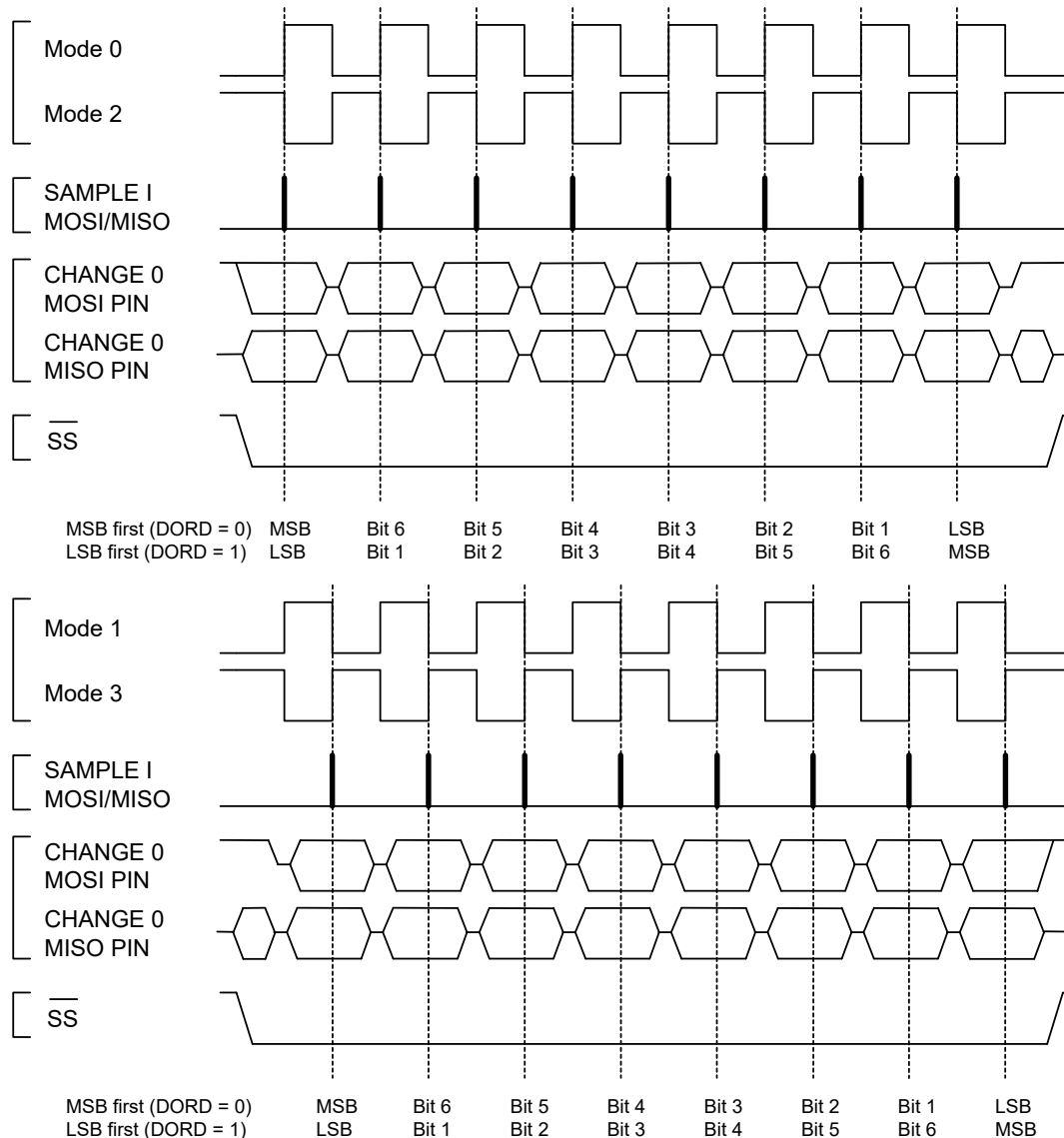
Leading edge is the first clock edge in a clock cycle.

Trailing edge is the second clock edge in a clock cycle.

# SAM D5x/E5x Family Data Sheet

## SERCOM SPI – SERCOM Serial Peripheral Interface

**Figure 35-3. SPI Transfer Modes**



### 35.6.2.6 Transferring Data

#### 35.6.2.6.1 Master

In Master mode (CTRLA.MODE=0x3), when Master Slave Enable Select (CTRLB.MSSEN) is '1', hardware will control the  $\overline{SS}$  line.

When Master Slave Select Enable (CTRLB.MSSEN) is '0', the  $\overline{SS}$  line must be configured as an output.  $\overline{SS}$  can be assigned to any general purpose I/O pin. When the SPI is ready for a data transaction, software must pull the  $\overline{SS}$  line low.

When writing a character to the Data register (DATA), the character will be transferred to the Shift register. Once the content of TxDATA has been transferred to the Shift register, the Data Register Empty flag in the Interrupt Flag Status and Clear register (INTFLAG.DRE) will be set. And a new character can be written to DATA.

Each time one character is shifted out from the master, another character will be shifted in from the slave simultaneously. If the receiver is enabled (CTRLA.RXEN=1), the contents of the Shift register will be

# SAM D5x/E5x Family Data Sheet

## SERCOM SPI – SERCOM Serial Peripheral Interface

---

transferred to the two-level receive buffer. The transfer takes place in the same clock cycle as the last data bit is shifted in. And the Receive Complete Interrupt flag in the Interrupt Flag Status and Clear register (INTFLAG.RXC) will be set. The received data can be retrieved by reading DATA.

When the last character has been transmitted and there is no valid data in DATA, the Transmit Complete Interrupt flag in the Interrupt Flag Status and Clear register (INTFLAG.TXC) will be set. When the transaction is finished, the master must pull the  $\overline{SS}$  line high to notify the slave. If Master Slave Select Enable (CTRLB.MSSEN) is set to '0', the software must pull the  $\overline{SS}$  line high.

### 35.6.2.6.2 Slave

In Slave mode (CTRLA.MODE=0x2), the SPI interface will remain inactive with the MISO line tri-stated as long as the  $\overline{SS}$  pin is pulled high. Software may update the contents of DATA at any time as long as the Data Register Empty flag in the Interrupt Status and Clear register (INTFLAG.DRE) is set.

When  $\overline{SS}$  is pulled low and SCK is running, the slave will sample and shift out data according to the Transaction mode set. When the content of TxDATA has been loaded into the Shift register, INTFLAG.DRE will be set, and new data can be written to DATA.

Similar to the master, the slave will receive one character for each character transmitted. A character will be transferred into the two-level receive buffer within the same clock cycle its last data bit is received. The received character can be retrieved from DATA when the Receive Complete interrupt flag (INTFLAG.RXC) is set.

When the master pulls the  $\overline{SS}$  line high, the transaction is done and the Transmit Complete Interrupt flag in the Interrupt Flag Status and Clear register (INTFLAG.TXC) will be set.

After DATA is written it takes up to three SCK clock cycles until the content of DATA is ready to be loaded into the Shift register on the next character boundary. As a consequence, the first character transferred in a SPI transaction will not be the content of DATA. This can be avoided by using the preloading feature. Refer to [35.6.3.2 Preloading of the Slave Shift Register](#).

When transmitting several characters in one SPI transaction, the data has to be written into DATA register with at least three SCK clock cycles left in the current character transmission. If this criteria is not met, the previously received character will be transmitted.

Once the DATA register is empty, it takes three CLK\_SERCOM\_APB cycles for INTFLAG.DRE to be set.

### 35.6.2.7 Receiver Error Bit

The SPI receiver has one error bit: the Buffer Overflow bit (BUFOVF), which can be read from the Status register (STATUS). Once an error happens, the bit will stay set until it is cleared by writing '1' to it. The bit is also automatically cleared when the receiver is disabled.

There are two methods for buffer overflow notification, selected by the immediate Buffer Overflow Notification bit in the Control A register (CTRLA.IBON):

If CTRLA.IBON=1, STATUS.BUFOVF is raised immediately upon buffer overflow. Software can then empty the receive FIFO by reading RxDATA until the receiver complete Interrupt flag in the Interrupt Flag Status and Clear register (INTFLAG.RXC) goes low.

If CTRLA.IBON=0, the Buffer Overflow condition travels with data through the receive FIFO. After the received data is read, STATUS.BUFOVF and INTFLAG.ERROR will be set along with INTFLAG.RXC, and RxDATA will be zero.



### 35.6.3 Additional Features

#### 35.6.3.1 Address Recognition

When the SPI is configured for slave operation (CTRLA.MODE=0x2) with address recognition (CTRLA.FORM is 0x2), the SERCOM address recognition logic is enabled: the first character in a transaction is checked for an address match.

If there is a match, the Receive Complete Interrupt flag in the Interrupt Flag Status and Clear register (INTFLAG.RXC) is set, the MISO output is enabled, and the transaction is processed. If the device is in Sleep mode, an address match can wake-up the device in order to process the transaction.

If there is no match, the complete transaction is ignored.

If a 9-bit frame format is selected, only the lower 8 bits of the Shift register are checked against the Address register (ADDR).

Preload must be disabled (CTRLB.PLOADEN=0) in order to use this mode.

#### Related Links

[33.6.3.1 Address Match and Mask](#)

#### 35.6.3.2 Preloading of the Slave Shift Register

When starting a transaction, the slave will first transmit the contents of the shift register before loading new data from DATA. The first character sent can be either the reset value of the shift register (if this is the first transmission since the last reset) or the last character in the previous transmission.

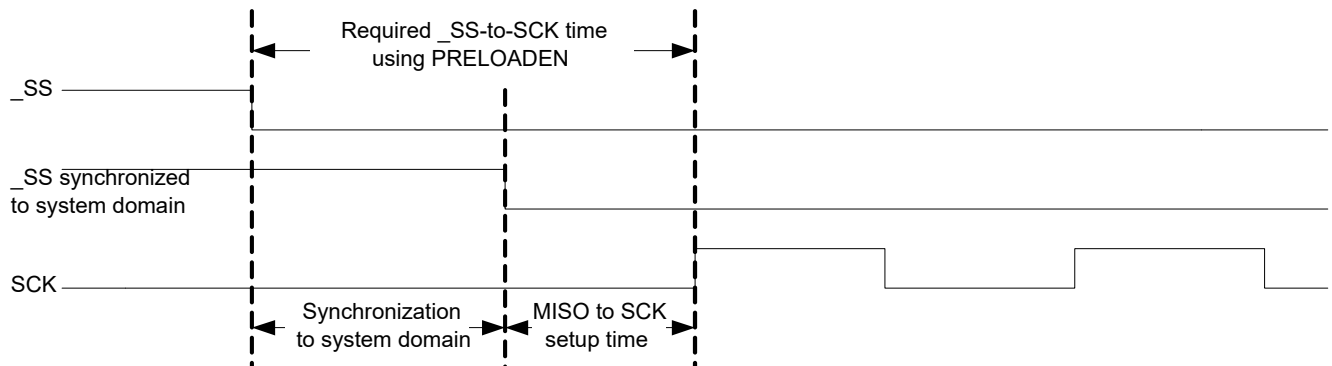
Preloading can be used to preload data into the shift register while  $\overline{SS}$  is high: this eliminates sending a dummy character when starting a transaction. If the shift register is not preloaded, the current contents of the shift register will be shifted out.

Only one data character will be preloaded into the shift register while the synchronized  $\overline{SS}$  signal is high. If the next character is written to DATA before  $\overline{SS}$  is pulled low, the second character will be stored in DATA until transfer begins.

For proper preloading, sufficient time must elapse between  $\overline{SS}$  going low and the first SCK sampling edge, as in [Timing Using Preloading](#). See also the *Electrical Characteristics* chapters for timing details.

Preloading is enabled by writing '1' to the Slave Data Preload Enable bit in the CTRLB register (CTRLB.PLOADEN).

**Figure 35-4. Timing Using Preloading**



#### 35.6.3.3 Master with Several Slaves

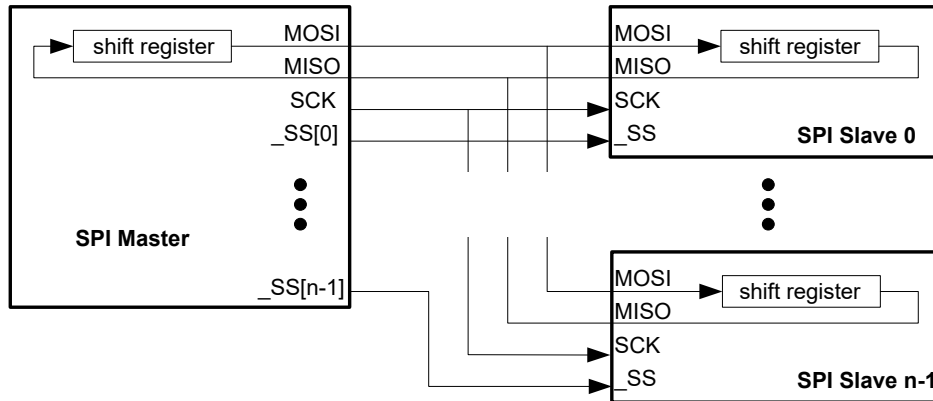
Master with multiple slaves in parallel is only available when Master Slave Select Enable (CTRLB.MSSEN) is set to zero and hardware  $\overline{SS}$  control is disabled. If the bus consists of several SPI

# SAM D5x/E5x Family Data Sheet

## SERCOM SPI – SERCOM Serial Peripheral Interface

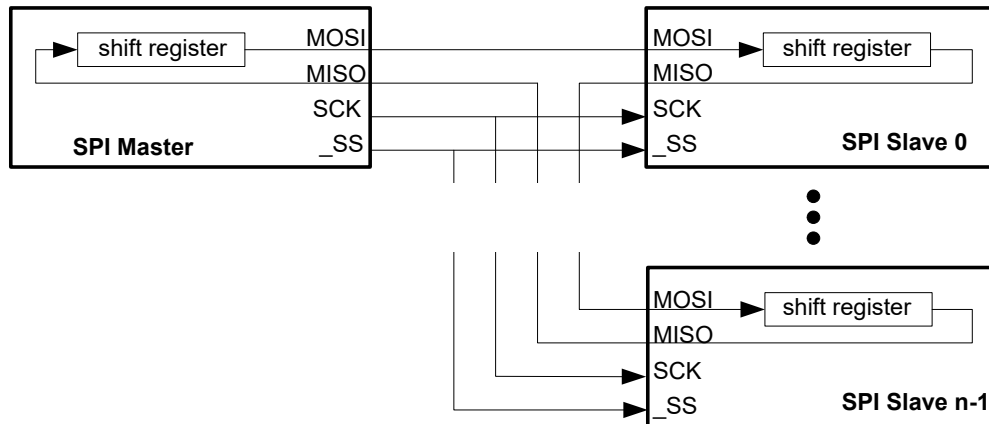
slaves, an SPI master can use general purpose I/O pins to control the  $\overline{SS}$  line to each of the slaves on the bus, as shown in [Multiple Slaves in Parallel](#). In this configuration, the single selected SPI slave will drive the tri-state MISO line.

**Figure 35-5. Multiple Slaves in Parallel**



Another configuration is multiple slaves in series, as in [Multiple Slaves in Series](#). In this configuration, all n attached slaves are connected in series. A common  $\overline{SS}$  line is provided to all slaves, enabling them simultaneously. The master must shift n characters for a complete transaction. Depending on the Master Slave Select Enable bit (CTRLB.MSSEN), the  $\overline{SS}$  line can be controlled either by hardware or user software and normal GPIO.

**Figure 35-6. Multiple Slaves in Series**



### 35.6.3.4 Loop-Back Mode

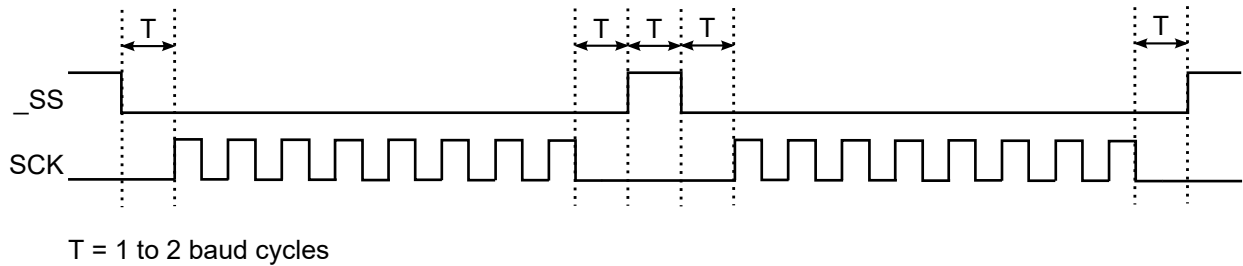
For Loop-back mode, configure the Data In Pinout (CTRLA.DIPO) and Data Out Pinout (CTRLA.DOPO) to use the same data pins for transmit and receive. The loop-back is through the pad, so the signal is also available externally.

### 35.6.3.5 Hardware Controlled $\overline{SS}$

In Master mode, a single  $\overline{SS}$  chip select can be controlled by hardware by writing the Master Slave Select Enable (CTRLB.MSSEN) bit to '1'. In this mode, the  $\overline{SS}$  pin is driven low for a minimum of one baud cycle before transmission begins, and stays low for a minimum of one baud cycle after transmission completes. If back-to-back frames are transmitted, the  $\overline{SS}$  pin will always be driven high for a minimum of one baud cycle between frames.

In [Hardware Controlled  \$\overline{SS}\$](#) , the time T is between one and two baud cycles depending on the SPI Transfer mode.

**Figure 35-7. Hardware Controlled  $\overline{SS}$**



When CTRLB.MSSEN=0, the  $\overline{SS}$  pin(s) is/are controlled by user software and normal GPIO.

### 35.6.3.6 Slave Select Low Detection

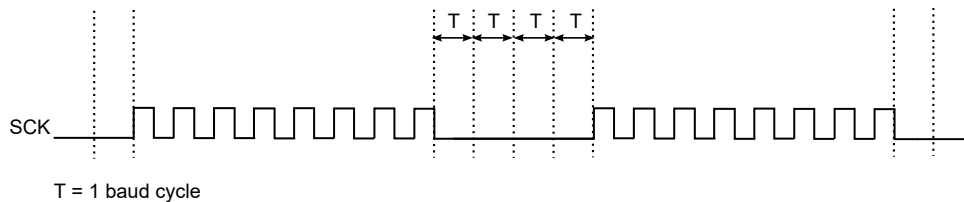
In Slave mode, the SPI can wake the CPU when the slave select ( $\overline{SS}$ ) goes low. When the Slave Select Low Detect is enabled (CTRLB.SSDE=1), a high-to-low transition will set the Slave Select Low Interrupt flag (INTFLAG.SSL) and the device will wake-up if applicable.

### 35.6.3.7 Master Inter-Character Spacing

When configured as master, inter-character spacing can be increased by writing a non-zero value to the Inter-Character Spacing bit field in the Control C register (CTRLC.ICSPACE). When non-zero, CTRLC.ICSPACE represents the minimum number of baud cycles that the SCK clock line does not toggle and the next character is stalled.

The figure gives an example for CTRLC.ICSPACE=4; In this case, the SCK is inactive for 4 baud cycles.

**Figure 35-8. Four Cycle Inter-Character Spacing Example**



### 35.6.3.8 32-bit Extension

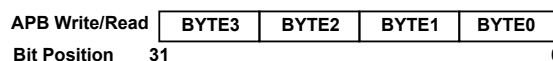
For better system bus utilization, 32-bit data receive and transmit can be enabled by writing to the Data 32-bit bit field in the Control C register (CTRLC.DATA32B=1). When enabled, write and read transaction to/from the DATA register are 32 bit in size.

If frames are not multiples of 4 Bytes, the Length Counter (LENGTH.LEN) and Length Enable (LENGTH.LENEN) must be configured before data transfer begins. LENGTH.LEN must be enabled only when CTRLC.DATA32B is enabled.

The figure below shows the order of transmit and receive when using 32-bit mode. Bytes are transmitted or received and stored in order from 0 to 3.

Only 8-bit character size is supported.

**Figure 35-9. 32-bit Extension Byte Ordering**



### 32-bit Extension Slave Operation

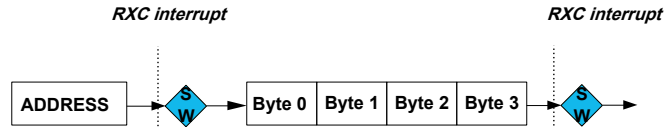
The figure below shows a transaction with 32-bit Extension enabled (CTRLC.DATA32B=1). When address recognition is enabled (CTRLA.FORM=0x2) and there is an address match, the address is

# SAM D5x/E5x Family Data Sheet

## SERCOM SPI – SERCOM Serial Peripheral Interface

loaded into the FIFO as Byte zero and data begins with Byte 1. INTFLAGS.RXC will then be raised for every 4 Bytes transferred. For transmit, there is a 32-bit holding buffer in the core domain. Once DATA has been registered in the core domain, INTFLAG.DRE will be raised, so that the next 32 bits can be written to the DATA register.

**Figure 35-10. 32-bit Extension Slave Operation**



When utilizing the length counter, the LENGTH register must be written before the frame begins. If the frame length while  $\overline{SS}$  is low is not a multiple of LENGTH.LEN Bytes, the Length Error Status bit (STATUS.LENERR) is raised. If LENGTH.LEN is not a multiple of 4 Bytes, the final INTFLAG.RXC interrupt will be raised when the last Byte is received.

The length count is based on the received Bytes, or the number of clocks if the receiver is not enabled. If pre-loading is disabled and DATA is written to for transmit before SCK starts, transmitted data will be delayed by one Byte, but the length counter will still increment for the first (empty) Byte transmission. When the counter reaches LENGTH.LEN, the internal length counter, Rx Byte counter, and Tx Byte counter are reset. If multiple lengths are to be transmitted, INTFLAG.TXC must go high before writing DATA for subsequent lengths.

If there is a Length Error (STATUS.LENERR), the remaining Bytes in the length will be transmitted at the beginning of the next frame. If this is not desired, the SERCOM must be disabled and re-enabled in order to flush the Tx and Rx pipelines.

Writing the LENGTH register while a frame is in progress will produce unpredictable results. If LENGTH.LENEN is not configured and a frame is not a multiple of 4 Bytes (while  $\overline{SS}$  is low), the remainder will be transmitted in the next frame.

### 32-bit Extension Master Operation

When using the SPI configured as Master, the Length and the Length Enable bit fields (LENGTH.LEN and LENGTH.LENEN) must be written before the frame begins. When LENGTH.LENEN is written to '1', the value of LENGTH.LEN determines the number of data bytes in the transaction from 1 to 255.

For receive data, INTFLAG.RXC is raised every 4 Bytes received. If LENGTH.LEN is not a multiple of 4 Bytes, the final INTFLAG.RXC is set when the final byte is received.

For transmit, there is a holding buffer for the 32-bit data in the core domain. Once DATA has been registered in the core domain, INTFLAG.DRE will be raised so that the next 32 bits can be written to the DATA register.

If multiple lengths are to be transmitted, INTFLAG.TXC must go high before writing DATA for subsequent lengths.

# SAM D5x/E5x Family Data Sheet

## SERCOM SPI – SERCOM Serial Peripheral Interface

### 35.6.4 DMA, Interrupts, and Events

**Table 35-4. Module Request for SERCOM SPI**

Condition	Request		
	DMA	Interrupt	Event
Data Register Empty (DRE)	Yes (request cleared when data is written)	Yes	NA
Receive Complete (RXC)	Yes (request cleared when data is read)	Yes	
Transmit Complete (TXC)	NA	Yes	
Slave Select low (SSL)	NA	Yes	
Error (ERROR)	NA	Yes	

#### 35.6.4.1 DMA Operation

The SPI generates the following DMA requests:

- Data received (RX): The request is set when data is available in the receive FIFO. The request is cleared when DATA is read.
- Data transmit (TX): The request is set when the transmit buffer (TX DATA) is empty. The request is cleared when DATA is written.

#### 35.6.4.2 Interrupts

The SPI has the following interrupt sources. These are asynchronous interrupts, and can wake-up the device from any Sleep mode:

- Data Register Empty (DRE)
- Receive Complete (RXC)
- Transmit Complete (TXC)
- Slave Select Low (SSL)
- Error (ERROR)

Each interrupt source has its own Interrupt flag. The Interrupt flag in the Interrupt Flag Status and Clear register (INTFLAG) will be set when the Interrupt condition is met. Each interrupt can be individually enabled by writing '1' to the corresponding bit in the Interrupt Enable Set register (INTENSET), and disabled by writing '1' to the corresponding bit in the Interrupt Enable Clear register (INTENCLR).

An interrupt request is generated when the Interrupt flag is set and if the corresponding interrupt is enabled. The interrupt request remains active until either the Interrupt flag is cleared, the interrupt is disabled, or the SPI is reset. For details on clearing Interrupt flags, refer to the INTFLAG register description.

The value of INTFLAG indicates which interrupt is executed. Note that interrupts must be globally enabled for interrupt requests. Refer to *Nested Vector Interrupt Controller* for details.

#### Related Links

[10.2 Nested Vector Interrupt Controller](#)

#### 35.6.4.3 Events

Not applicable.

### 35.6.5 Sleep Mode Operation

The behavior in Sleep mode is depending on the master/slave configuration and the Run In Standby bit in the Control A register (CTRLA.RUNSTDBY):

- Master operation, CTRLA.RUNSTDBY=1: The peripheral clock GCLK\_SERCOM\_CORE will continue to run in Idle Sleep mode and in Standby Sleep mode. Any interrupt can wake-up the device.
- Master operation, CTRLA.RUNSTDBY=0: GLK\_SERCOMx\_CORE will be disabled after the ongoing transaction is finished. Any interrupt can wake up the device.
- Slave operation, CTRLA.RUNSTDBY=1: The Receive Complete interrupt can wake-up the device.
- Slave operation, CTRLA.RUNSTDBY=0: All reception will be dropped, including the ongoing transaction.

### 35.6.6 Synchronization

Due to asynchronicity between the main clock domain and the peripheral clock domains, some registers need to be synchronized when written or read.

The following bits are synchronized when written:

- Software Reset bit in the CTRLA register (CTRLA.SWRST)
- Enable bit in the CTRLA register (CTRLA.ENABLE)
- Receiver Enable bit in the CTRLB register (CTRLB.RXEN)

**Note:** CTRLB.RXEN is write-synchronized somewhat differently. See also *CTRLB* register for details.

Required write synchronization is denoted by the "Write-Synchronized" property in the register description.

# SAM D5x/E5x Family Data Sheet

## SERCOM SPI – SERCOM Serial Peripheral Interface

### 35.7 Register Summary

Offset	Name	Bit Pos.								
0x00	CTRLA	7:0	RUNSTDBY				MODE[2:0]	ENABLE	SWRST	
		15:8							IBON	
		23:16				DIPO[1:0]			DOPO[1:0]	
		31:24		DORD	CPOL	CPHA		FORM[3:0]		
0x04	CTRLB	7:0		PLOADEN				CHSIZE[2:0]		
		15:8		AMODE[1:0]	MSEN			SSDE		
		23:16						RXEN		
		31:24								
0x08	CTRLC	7:0					ICSPACE[5:0]			
		15:8								
		23:16								
		31:24							DATA32B	
0x0C	BAUD	7:0				BAUD[7:0]				
0x0D ... 0x13	Reserved									
0x14	INTENCLR	7:0	ERROR			SSL	RXC	TXC	DRE	
0x15	Reserved									
0x16	INTENSET	7:0	ERROR			SSL	RXC	TXC	DRE	
0x17	Reserved									
0x18	INTFLAG	7:0	ERROR			SSL	RXC	TXC	DRE	
0x19	Reserved									
0x1A	STATUS	7:0						BUFOVF		
		15:8					LENERR			
0x1C	SYNDBUSY	7:0				LENGTH		CTRLB	ENABLE	SWRST
		15:8								
		23:16								
		31:24								
0x20 ... 0x21	Reserved									
0x22	LENGTH	7:0					LEN[7:0]			
		15:8							LENEN	
0x24	ADDR	7:0					ADDR[7:0]			
		15:8								
		23:16					ADDRMASK[7:0]			
		31:24								
0x28	DATA	7:0					DATA[7:0]			
		15:8					DATA[15:8]			
		23:16					DATA[23:16]			
		31:24					DATA[31:24]			

# SAM D5x/E5x Family Data Sheet

## SERCOM SPI – SERCOM Serial Peripheral Interface

.....continued

Offset	Name	Bit Pos.								
0x2C	Reserved									
...										
0x2F										
0x30	DBGCTRL	7:0								DBGSTOP

### 35.8 Register Description

Registers can be 8, 16, or 32 bits wide. Atomic 8-, 16-, and 32-bit accesses are supported. In addition, the 8-bit quarters and 16-bit halves of a 32-bit register, and the 8-bit halves of a 16-bit register can be accessed directly.

Some registers require synchronization when read and/or written. Synchronization is denoted by the "Read-Synchronized" and/or "Write-Synchronized" property in each individual register description.

Refer to [35.6.6 Synchronization](#)

Some registers are enable-protected, meaning they can only be written when the module is disabled. Enable protection is denoted by the "Enable-Protected" property in each individual register description.

Optional write protection by the Peripheral Access Controller (PAC) is denoted by the "PAC Write Protection" property in each individual register description.

Refer to [35.5.8 Register Access Protection](#).



# SAM D5x/E5x Family Data Sheet

## SERCOM SPI – SERCOM Serial Peripheral Interface

### 35.8.1 Control A

**Name:** CTRLA  
**Offset:** 0x00  
**Reset:** 0x00000000  
**Property:** PAC Write-Protection, Enable-Protected, Write-Synchronized

	Bit	31	30	29	28	27	26	25	24
			DORD	CPOL	CPHA	FORM[3:0]			
Access			R/W	R/W	R/W	R/W	R/W	R/W	R/W
Reset			0	0	0	0	0	0	0
	Bit	23	22	21	20	19	18	17	16
				DIPO[1:0]				DOPO[1:0]	
Access				R/W	R/W			R/W	R/W
Reset				0	0			0	0
	Bit	15	14	13	12	11	10	9	8
									IBON
Access									R/W
Reset									0
	Bit	7	6	5	4	3	2	1	0
		RUNSTDBY			MODE[2:0]			ENABLE	SWRST
Access		R/W			R/W	R/W	R/W	R/W	R/W
Reset		0			0	0	0	0	0

#### Bit 30 – DORD Data Order

This bit selects the data order when a character is shifted out from the Shift register. This bit is not synchronized.

Value	Description
0	MSB is transferred first.
1	LSB is transferred first.

#### Bit 29 – CPOL Clock Polarity

In combination with the Clock Phase bit (CPHA), this bit determines the SPI Transfer mode. This bit is not synchronized.

Value	Description
0	SCK is low when idle. The leading edge of a clock cycle is a rising edge, while the trailing edge is a falling edge.
1	SCK is high when idle. The leading edge of a clock cycle is a falling edge, while the trailing edge is a rising edge.

#### Bit 28 – CPHA Clock Phase

In combination with the Clock Polarity bit (CPOL), this bit determines the SPI Transfer mode. This bit is not synchronized.

# SAM D5x/E5x Family Data Sheet

## SERCOM SPI – SERCOM Serial Peripheral Interface

Mode	CPOL	CPHA	Leading Edge	Trailing Edge
0x0	0	0	Rising, sample	Falling, change
0x1	0	1	Rising, change	Falling, sample
0x2	1	0	Falling, sample	Rising, change
0x3	1	1	Falling, change	Rising, sample

Value	Description
0	The data is sampled on a leading SCK edge and changed on a trailing SCK edge.
1	The data is sampled on a trailing SCK edge and changed on a leading SCK edge.

### Bits 27:24 – FORM[3:0] Frame Format

This bit field selects the various frame formats supported by the SPI in Slave mode. When the 'SPI frame with address' format is selected, the first byte received is checked against the ADDR register.

FORM[3:0]	Name	Description
0x0	SPI	SPI frame
0x1	-	Reserved
0x2	SPI_ADDR	SPI frame with address
0x3-0xF	-	Reserved

### Bits 21:20 – DIPO[1:0] Data In Pinout

These bits define the Data In (DI) pad configurations.

In master operation, DI is MISO.

In slave operation, DI is MOSI.

These bits are not synchronized.

DIPO[1:0]	Name	Description
0x0	PAD[0]	SERCOM PAD[0] is used as data input
0x1	PAD[1]	SERCOM PAD[1] is used as data input
0x2	PAD[2]	SERCOM PAD[2] is used as data input
0x3	PAD[3]	SERCOM PAD[3] is used as data input

### Bits 17:16 – DOPO[1:0] Data Out Pinout

This bit defines the available pad configurations for Data Out (DO) and the Serial Clock (SCK). In slave operation, the Slave Select ( $\overline{SS}$ ) line is controlled by DOPO, while in master operation the  $\overline{SS}$  line is controlled by the port configuration.

In master operation, DO is MOSI.

In slave operation, DO is MISO.

These bits are not synchronized.

DOPO	DO	SCK	Slave $\overline{SS}$	Master $\overline{SS}$
0x0	PAD[0]	PAD[1]	PAD[2]	PAD[2] Master $\overline{SS}$ pin when MSEN = 1 otherwise System configuration

# SAM D5x/E5x Family Data Sheet

## SERCOM SPI – SERCOM Serial Peripheral Interface

.....continued				
DOPO	DO	SCK	Slave $\overline{SS}$	Master $\overline{SS}$
0x1	Reserved			
0x2	PAD[3]	PAD[1]	PAD[2]	PAD[2] Master $\overline{SS}$ pin when MSSEN = 1 otherwise System configuration
0x3	Reserved			

### Bit 8 – IBON Immediate Buffer Overflow Notification

This bit controls when the Buffer Overflow Status bit (STATUS.BUFOVF) is set when a buffer overflow occurs.

This bit is not synchronized.

Value	Description
0	STATUS.BUFOVF is set when it occurs in the data stream.
1	STATUS.BUFOVF is set immediately upon buffer overflow.

### Bit 7 – RUNSTDBY Run In Standby

This bit defines the functionality in Standby Sleep mode.

These bits are not synchronized.

RUNSTDBY	Slave	Master
0x0	Disabled. All reception is dropped, including the ongoing transaction.	Generic clock is disabled when ongoing transaction is finished. All interrupts can wake-up the device.
0x1	Ongoing transaction continues, wake on Receive Complete interrupt.	Generic clock is enabled while in sleep modes. All interrupts can wake-up the device.

### Bits 4:2 – MODE[2:0] Operating Mode

These bits must be written to 0x2 or 0x3 to select the SPI of the SERCOM.

0x2: SPI slave operation

0x3: SPI master operation

These bits are not synchronized.

### Bit 1 – ENABLE Enable

Due to synchronization, there is delay from writing CTRLA.ENABLE until the peripheral is enabled/disabled. The value written to CTRL.ENABLE will read back immediately and the Synchronization Enable Busy bit in the Synchronization Busy register (SYNCBUSY.ENABLE) will be set. SYNCBUSY.ENABLE is cleared when the operation is complete.

This bit is not enable-protected.

Value	Description
0	The peripheral is disabled or being disabled.
1	The peripheral is enabled or being enabled.

### Bit 0 – SWRST Software Reset

Writing '0' to this bit has no effect.

Writing '1' to this bit resets all registers in the SERCOM, except DBGCTRL, to their initial state, and the SERCOM will be disabled.

# SAM D5x/E5x Family Data Sheet

## SERCOM SPI – SERCOM Serial Peripheral Interface

---

Writing "1" to CTRL.SWRST will always take precedence, meaning that all other writes in the same write-operation will be discarded. Any register write access during the ongoing Reset will result in an APB error. Reading any register will return the Reset value of the register.

Due to synchronization, there is a delay from writing CTRLA.SWRST until the Reset is complete.

CTRLA.SWRST and SYNCBUSY.SWRST will both be cleared when the Reset is complete.

This bit is not enable-protected.

Value	Description
0	There is no Reset operation ongoing.
1	The Reset operation is ongoing.

# SAM D5x/E5x Family Data Sheet

## SERCOM SPI – SERCOM Serial Peripheral Interface

### 35.8.2 Control B

**Name:** CTRLB  
**Offset:** 0x04  
**Reset:** 0x00000000  
**Property:** PAC Write-Protection, Enable-Protected, Write-Synchronized

Bit	31	30	29	28	27	26	25	24
Access								
Reset								
Bit	23	22	21	20	19	18	17	16
Access							RXEN	
Reset							0	
Bit	15	14	13	12	11	10	9	8
Access	AMODE[1:0]		MSSEN				SSDE	
Reset	0	0	0				0	
Bit	7	6	5	4	3	2	1	0
Access	PLOADEN					CHSIZE[2:0]		
Reset	0					0	0	0

#### Bit 17 – RXEN Receiver Enable

Writing '0' to this bit will disable the SPI receiver immediately. The receive buffer will be flushed, data from ongoing receptions will be lost and STATUS.BUFOVF will be cleared.

Writing '1' to CTRLB.RXEN when the SPI is disabled will set CTRLB.RXEN immediately. When the SPI is enabled, CTRLB.RXEN will be cleared, SYNCBUSY.CTRLB will be set and remain set until the receiver is enabled. When the receiver is enabled CTRLB.RXEN will read back as '1'.

Writing '1' to CTRLB.RXEN when the SPI is enabled will set SYNCBUSY.CTRLB, which will remain set until the receiver is enabled, and CTRLB.RXEN will read back as '1'.

This bit is not enable-protected.

Value	Description
0	The receiver is disabled or being enabled.
1	The receiver is enabled or it will be enabled when SPI is enabled.

#### Bits 15:14 – AMODE[1:0] Address Mode

These bits set the Slave Addressing mode when the frame format (CTRLA.FORM) with address is used. They are unused in Master mode.

AMODE[1:0]	Name	Description
0x0	MASK	ADDRMASK is used as a mask to the ADDR register
0x1	2_ADDRS	The slave responds to the two unique addresses in ADDR and ADDRMASK

# SAM D5x/E5x Family Data Sheet

## SERCOM SPI – SERCOM Serial Peripheral Interface

.....continued

AMODE[1:0]	Name	Description
0x2	RANGE	The slave responds to the range of addresses between and including ADDR and ADDRMASK. ADDR is the upper limit
0x3	-	Reserved

### Bit 13 – MSSEN Master Slave Select Enable

This bit enables hardware Slave Select ( $\overline{SS}$ ) control.

Value	Description
0	Hardware $\overline{SS}$ control is disabled.
1	Hardware $\overline{SS}$ control is enabled.

### Bit 9 – SSDE Slave Select Low Detect Enable

This bit enables wake-up when the Slave Select ( $\overline{SS}$ ) pin transitions from high to low.

Value	Description
0	$\overline{SS}$ low detector is disabled.
1	$\overline{SS}$ low detector is enabled.

### Bit 6 – PLOADEN Slave Data Preload Enable

Setting this bit will enable preloading of the Slave Shift register when there is no transfer in progress. If the  $\overline{SS}$  line is high when DATA is written, it will be transferred immediately to the Shift register.

### Bits 2:0 – CHSIZE[2:0] Character Size

CHSIZE[2:0]	Name	Description
0x0	8BIT	8 bits
0x1	9BIT	9 bits
0x2-0x7	-	Reserved

# SAM D5x/E5x Family Data Sheet

## SERCOM SPI – SERCOM Serial Peripheral Interface

### 35.8.3 Control C

**Name:** CTRLC  
**Offset:** 0x08  
**Reset:** 0x00000000  
**Property:** PAC Write-Protection, Enable-Protected

	Bit	31	30	29	28	27	26	25	24
									DATA32B
Access									R/W
Reset									0
	Bit	23	22	21	20	19	18	17	16
Access									
Reset									
	Bit	15	14	13	12	11	10	9	8
Access									
Reset									
	Bit	7	6	5	4	3	2	1	0
				ICSPACE[5:0]					
Access				R/W	R/W	R/W	R/W	R/W	R/W
Reset				0	0	0	0	0	0

#### Bit 24 – DATA32B Data 32 Bit

This bit enables 32-bit Extension for read and write transactions to the DATA register. When disabled, access is according to CTRLB.CHSIZE.

Value	Description
0	Transactions from and to DATA register are 8-bit
1	Transactions from and to DATA register are 32-bit

#### Bits 5:0 – ICSPACE[5:0] Inter-Character Spacing

When non-zero, CTRLC.ICSPACE selects the minimum number of baud cycles the SCK line will not toggle between characters.

Value	Description
0x00	Inter-Character Spacing is disabled
0x01-0x3F	The minimum Inter-Character Spacing

# SAM D5x/E5x Family Data Sheet

## SERCOM SPI – SERCOM Serial Peripheral Interface

### 35.8.4 Baud Rate

**Name:** BAUD  
**Offset:** 0x0C  
**Reset:** 0x00  
**Property:** PAC Write-Protection, Enable-Protected

Bit	7	6	5	4	3	2	1	0
	BAUD[7:0]							
Access	R/W	R/W	R/W	R/W	R/W	R/W	R/W	R/W
Reset	0	0	0	0	0	0	0	0

#### Bits 7:0 – BAUD[7:0] Baud Register

These bits control the clock generation, as described in the *SERCOM Clock Generation – Baud-Rate Generator*.

#### Related Links

[33.6.2.3 Clock Generation – Baud-Rate Generator](#)



# SAM D5x/E5x Family Data Sheet

## SERCOM SPI – SERCOM Serial Peripheral Interface

### 35.8.5 Interrupt Enable Clear

**Name:** INTENCLR  
**Offset:** 0x14  
**Reset:** 0x00  
**Property:** PAC Write-Protection

This register allows the user to disable an interrupt without read-modify-write operation. Changes in this register will also be reflected in the Interrupt Enable Set register (INTENSET).

Bit	7	6	5	4	3	2	1	0
	ERROR				SSL	RXC	TXC	DRE
Access	R/W				R/W	R/W	R/W	R/W
Reset	0				0	0	0	0

#### Bit 7 – ERROR Error Interrupt Enable

Writing '0' to this bit has no effect.

Writing '1' to this bit will clear the Error Interrupt Enable bit, which disables the Error interrupt.

Value	Description
0	Error interrupt is disabled.
1	Error interrupt is enabled.

#### Bit 3 – SSL Slave Select Low Interrupt Enable

Writing '0' to this bit has no effect.

Writing '1' to this bit will clear the Slave Select Low Interrupt Enable bit, which disables the Slave Select Low interrupt.

Value	Description
0	Slave Select Low interrupt is disabled.
1	Slave Select Low interrupt is enabled.

#### Bit 2 – RXC Receive Complete Interrupt Enable

Writing '0' to this bit has no effect.

Writing '1' to this bit will clear the Receive Complete Interrupt Enable bit, which disables the Receive Complete interrupt.

Value	Description
0	Receive Complete interrupt is disabled.
1	Receive Complete interrupt is enabled.

#### Bit 1 – TXC Transmit Complete Interrupt Enable

Writing '0' to this bit has no effect.

Writing '1' to this bit will clear the Transmit Complete Interrupt Enable bit, which disable the Transmit Complete interrupt.

Value	Description
0	Transmit Complete interrupt is disabled.
1	Transmit Complete interrupt is enabled.

#### Bit 0 – DRE Data Register Empty Interrupt Enable

Writing '0' to this bit has no effect.

Writing '1' to this bit will clear the Data Register Empty Interrupt Enable bit, which disables the Data Register Empty interrupt.

# SAM D5x/E5x Family Data Sheet

## SERCOM SPI – SERCOM Serial Peripheral Interface

Value	Description
0	Data Register Empty interrupt is disabled.
1	Data Register Empty interrupt is enabled.

# SAM D5x/E5x Family Data Sheet

## SERCOM SPI – SERCOM Serial Peripheral Interface

### 35.8.6 Interrupt Enable Set

**Name:** INTENSET  
**Offset:** 0x16  
**Reset:** 0x00  
**Property:** PAC Write-Protection

This register allows the user to disable an interrupt without read-modify-write operation. Changes in this register will also be reflected in the Interrupt Enable Clear register (INTENCLR).

Bit	7	6	5	4	3	2	1	0
	ERROR				SSL	RXC	TXC	DRE
Access	R/W				R/W	R/W	R/W	R/W
Reset	0				0	0	0	0

#### Bit 7 – ERROR Error Interrupt Enable

Writing '0' to this bit has no effect.

Writing '1' to this bit will set the Error Interrupt Enable bit, which enables the Error interrupt.

Value	Description
0	Error interrupt is disabled.
1	Error interrupt is enabled.

#### Bit 3 – SSL Slave Select Low Interrupt Enable

Writing '0' to this bit has no effect.

Writing '1' to this bit will set the Slave Select Low Interrupt Enable bit, which enables the Slave Select Low interrupt.

Value	Description
0	Slave Select Low interrupt is disabled.
1	Slave Select Low interrupt is enabled.

#### Bit 2 – RXC Receive Complete Interrupt Enable

Writing '0' to this bit has no effect.

Writing '1' to this bit will set the Receive Complete Interrupt Enable bit, which enables the Receive Complete interrupt.

Value	Description
0	Receive Complete interrupt is disabled.
1	Receive Complete interrupt is enabled.

#### Bit 1 – TXC Transmit Complete Interrupt Enable

Writing '0' to this bit has no effect.

Writing '1' to this bit will set the Transmit Complete Interrupt Enable bit, which enables the Transmit Complete interrupt.

Value	Description
0	Transmit Complete interrupt is disabled.
1	Transmit Complete interrupt is enabled.

#### Bit 0 – DRE Data Register Empty Interrupt Enable

Writing '0' to this bit has no effect.

Writing '1' to this bit will set the Data Register Empty Interrupt Enable bit, which enables the Data Register Empty interrupt.

# SAM D5x/E5x Family Data Sheet

## SERCOM SPI – SERCOM Serial Peripheral Interface

Value	Description
0	Data Register Empty interrupt is disabled.
1	Data Register Empty interrupt is enabled.

# SAM D5x/E5x Family Data Sheet

## SERCOM SPI – SERCOM Serial Peripheral Interface

### 35.8.7 Interrupt Flag Status and Clear

**Name:** INTFLAG  
**Offset:** 0x18  
**Reset:** 0x00  
**Property:** -

	7	6	5	4	3	2	1	0
	ERROR				SSL	RXC	TXC	DRE
Access	R/W				R/W	R	R/W	R
Reset	0				0	0	0	0

#### Bit 7 – ERROR Error

This flag is cleared by writing '1' to it.

This bit is set when any error is detected. Errors that will set this flag have corresponding Status flags in the STATUS register. The BUFOVF error and the LENERR error will set this Interrupt flag.

Writing '0' to this bit has no effect.

Writing '1' to this bit will clear the flag.

#### Bit 3 – SSL Slave Select Low

This flag is cleared by writing '1' to it.

This bit is set when a high to low transition is detected on the `_SS` pin in Slave mode and Slave Select Low Detect (`CTRLB.SSDE`) is enabled.

Writing '0' to this bit has no effect.

Writing '1' to this bit will clear the flag.

#### Bit 2 – RXC Receive Complete

This flag is cleared by reading the Data (`DATA`) register or by disabling the receiver.

This flag is set when there are unread data in the receive buffer. If address matching is enabled, the first data received in a transaction will be an address.

Writing '0' to this bit has no effect.

Writing '1' to this bit has no effect.

#### Bit 1 – TXC Transmit Complete

This flag is cleared by writing '1' to it or by writing new data to `DATA`.

In Master mode, this flag is set when the data have been shifted out and there are no new data in `DATA`. In Slave mode, this flag is set when the `_SS` pin is pulled high. If address matching is enabled, this flag is only set if the transaction was initiated with an address match.

Writing '0' to this bit has no effect.

Writing '1' to this bit will clear the flag.

#### Bit 0 – DRE Data Register Empty

This flag is cleared by writing new data to `DATA`.

This flag is set when `DATA` is empty and ready for new data to transmit.

Writing '0' to this bit has no effect.

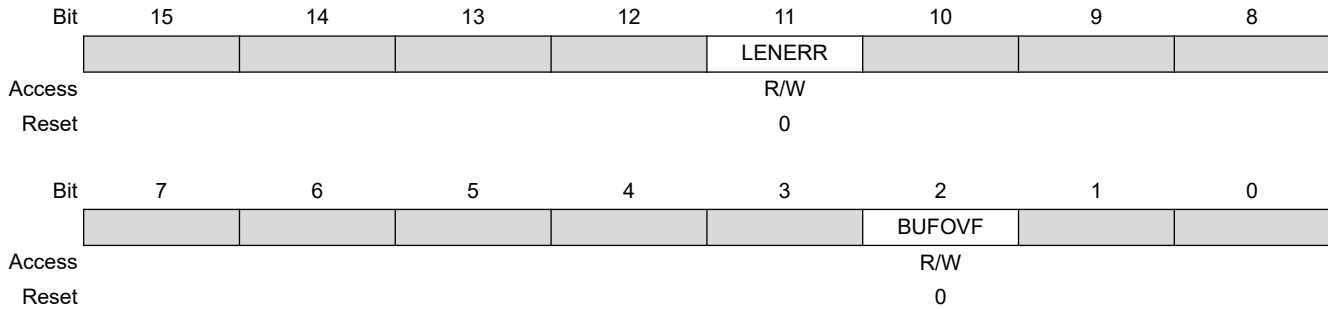
Writing '1' to this bit has no effect.

# SAM D5x/E5x Family Data Sheet

## SERCOM SPI – SERCOM Serial Peripheral Interface

### 35.8.8 Status

**Name:** STATUS  
**Offset:** 0x1A  
**Reset:** 0x0000  
**Property:** –



#### Bit 11 – LENERR Transaction Length Error

This bit is set in slave mode when the length counter is enabled (LENGTH.LENEN=1) and the transfer length while  $\overline{SS}$  is low is not a multiple of LENGTH.LEN.

Writing '0' to this bit has no effect.

Writing '1' to this bit will clear it.

Value	Description
0	No Length Error has occurred.
1	A Length Error has occurred.

#### Bit 2 – BUFOVF Buffer Overflow

Reading this bit before reading DATA will indicate the error status of the next character to be read.

This bit is cleared by writing '1' to the bit or by disabling the receiver.

This bit is set when a Buffer Overflow condition is detected. See also [CTRLA.IBON](#) for overflow handling. When set, the corresponding RxDATA will be zero.

Writing '0' to this bit has no effect.

Writing '1' to this bit will clear it.

Value	Description
0	No Buffer Overflow has occurred.
1	A Buffer Overflow has occurred.

# SAM D5x/E5x Family Data Sheet

## SERCOM SPI – SERCOM Serial Peripheral Interface

### 35.8.9 Synchronization Busy

**Name:** SYNCBUSY  
**Offset:** 0x1C  
**Reset:** 0x00000000  
**Property:** -

	31	30	29	28	27	26	25	24	
Access									
Reset									
	23	22	21	20	19	18	17	16	
Access									
Reset									
	15	14	13	12	11	10	9	8	
Access									
Reset									
	7	6	5	4	3	2	1	0	
				LENGTH			CTRLB	ENABLE	SWRST
Access				R			R	R	R
Reset				0			0	0	0

#### Bit 4 – LENGTH LENGTH Synchronization Busy

Writing to the LENGTH register requires synchronization. When writing to LENGTH, SYNCBUSY.LENGTH will be set until synchronization is complete. If the LENGTH register is written to while SYNCBUSY.LENGTH is asserted, an APB error is generated.

**Note:** In slave mode, the clock is only running during data transfer, so SYNCBUSY.LENGTH will remain asserted until the next data transfer begins.

Value	Description
0	LENGTH synchronization is not busy.
1	LENGTH synchronization is busy.

#### Bit 2 – CTRLB CTRLB Synchronization Busy

Writing to the CTRLB when the SERCOM is enabled requires synchronization. Ongoing synchronization is indicated by SYNCBUSY.CTRLB=1 until synchronization is complete. If CTRLB is written while SYNCBUSY.CTRLB=1, an APB error will be generated.

Value	Description
0	CTRLB synchronization is not busy.
1	CTRLB synchronization is busy.

#### Bit 1 – ENABLE SERCOM Enable Synchronization Busy

Enabling and disabling the SERCOM (CTRLA.ENABLE) requires synchronization. Ongoing synchronization is indicated by SYNCBUSY.ENABLE=1 until synchronization is complete.

# SAM D5x/E5x Family Data Sheet

## SERCOM SPI – SERCOM Serial Peripheral Interface

Value	Description
0	Enable synchronization is not busy.
1	Enable synchronization is busy.

### Bit 0 – SWRST Software Reset Synchronization Busy

Resetting the SERCOM (CTRLA.SWRST) requires synchronization. Ongoing synchronization is indicated by SYNCBUSY.SWRST=1 until synchronization is complete.

Value	Description
0	SWRST synchronization is not busy.
1	SWRST synchronization is busy.



# SAM D5x/E5x Family Data Sheet

## SERCOM SPI – SERCOM Serial Peripheral Interface

### 35.8.10 Length

**Name:** LENGTH  
**Offset:** 0x22  
**Reset:** 0x0000  
**Property:** PAC Write-Protection, Write-Synchronized

Bit	15	14	13	12	11	10	9	8
								LENEN
Access								R/W
Reset								0
Bit	7	6	5	4	3	2	1	0
	LEN[7:0]							
Access	R/W	R/W	R/W	R/W	R/W	R/W	R/W	R/W
Reset	0	0	0	0	0	0	0	0

#### Bit 8 – LENEN Data Length Enable

In 32-bit Extension mode, this bit field enables the length counter.

Value	Description
0	Length counter disabled
1	Length counter enabled

#### Bits 7:0 – LEN[7:0] Data Length

In 32-bit Extension mode, this bit field configures the data length after which the flags INTFLAG.RCX or INTFLAG.DRE are raised.

Value	Description
0x00	Reserved if LENEN=0x1
0x01-0xFF	Data Length

# SAM D5x/E5x Family Data Sheet

## SERCOM SPI – SERCOM Serial Peripheral Interface

### 35.8.11 Address

**Name:** ADDR  
**Offset:** 0x24  
**Reset:** 0x00000000  
**Property:** PAC Write-Protection, Enable-Protected

Bit	31	30	29	28	27	26	25	24
Access								
Reset								
Bit	23	22	21	20	19	18	17	16
	ADDRMASK[7:0]							
Access	R/W	R/W	R/W	R/W	R/W	R/W	R/W	R/W
Reset	0	0	0	0	0	0	0	0
Bit	15	14	13	12	11	10	9	8
Access								
Reset								
Bit	7	6	5	4	3	2	1	0
	ADDR[7:0]							
Access	R/W	R/W	R/W	R/W	R/W	R/W	R/W	R/W
Reset	0	0	0	0	0	0	0	0

**Bits 23:16 – ADDRMASK[7:0] Address Mask**

These bits hold the address mask when the transaction format with address is used (CTRLA.FORM, CTRLB.AMODE).

**Bits 7:0 – ADDR[7:0] Address**

These bits hold the address when the transaction format with address is used (CTRLA.FORM, CTRLB.AMODE).

# SAM D5x/E5x Family Data Sheet

## SERCOM SPI – SERCOM Serial Peripheral Interface

### 35.8.12 Data

**Name:** DATA  
**Offset:** 0x28  
**Reset:** 0x0000  
**Property:** –

Bit	31	30	29	28	27	26	25	24
	DATA[31:24]							
Access	R/W	R/W	R/W	R/W	R/W	R/W	R/W	R/W
Reset	0	0	0	0	0	0	0	0
Bit	23	22	21	20	19	18	17	16
	DATA[23:16]							
Access	R/W	R/W	R/W	R/W	R/W	R/W	R/W	R/W
Reset	0	0	0	0	0	0	0	0
Bit	15	14	13	12	11	10	9	8
	DATA[15:8]							
Access	R/W	R/W	R/W	R/W	R/W	R/W	R/W	R/W
Reset	0	0	0	0	0	0	0	0
Bit	7	6	5	4	3	2	1	0
	DATA[7:0]							
Access	R/W	R/W	R/W	R/W	R/W	R/W	R/W	R/W
Reset	0	0	0	0	0	0	0	0

#### Bits 31:0 – DATA[31:0] Data

Reading these bits will return the contents of the receive data buffer. The register should be read only when the Receive Complete Interrupt Flag bit in the Interrupt Flag Status and Clear register (INTFLAG.RXC) is set.

Writing these bits will write the transmit data buffer. This register should be written only when the Data Register Empty Interrupt Flag bit in the Interrupt Flag Status and Clear register (INTFLAG.DRE) is set. Reads and writes are 32-bit or CTLB.CHSIZE based on the CTRLC.DATA32B setting.

# SAM D5x/E5x Family Data Sheet

## SERCOM SPI – SERCOM Serial Peripheral Interface

### 35.8.13 Debug Control

**Name:** DBGCTRL  
**Offset:** 0x30  
**Reset:** 0x00  
**Property:** PAC Write-Protection

Bit	7	6	5	4	3	2	1	0
								DBGSTOP
Access								R/W
Reset								0

#### Bit 0 – DBGSTOP Debug Stop Mode

This bit controls the functionality when the CPU is halted by an external debugger.

Value	Description
0	The baud-rate generator continues normal operation when the CPU is halted by an external debugger.
1	The baud-rate generator is halted when the CPU is halted by an external debugger.

## 36. SERCOM I<sup>2</sup>C – Inter-Integrated Circuit

### 36.1 Overview

The Inter-Integrated Circuit (I<sup>2</sup>C) interface is one of the available modes in the Serial Communication Interface (SERCOM).

The I<sup>2</sup>C interface uses the SERCOM transmitter and receiver configured as shown in [Figure 36-1](#). Labels in capital letters are registers accessible by the CPU, while lowercase labels are internal to the SERCOM.

A SERCOM instance can be configured to be either an I<sup>2</sup>C master or an I<sup>2</sup>C slave. Both master and slave have an interface containing a Shift register, a transmit buffer and a receive buffer. In addition, the I<sup>2</sup>C master uses the SERCOM baud-rate generator, while the I<sup>2</sup>C slave uses the SERCOM address match logic.

#### Related Links

[33. SERCOM – Serial Communication Interface](#)

### 36.2 Features

SERCOM I<sup>2</sup>C includes the following features:

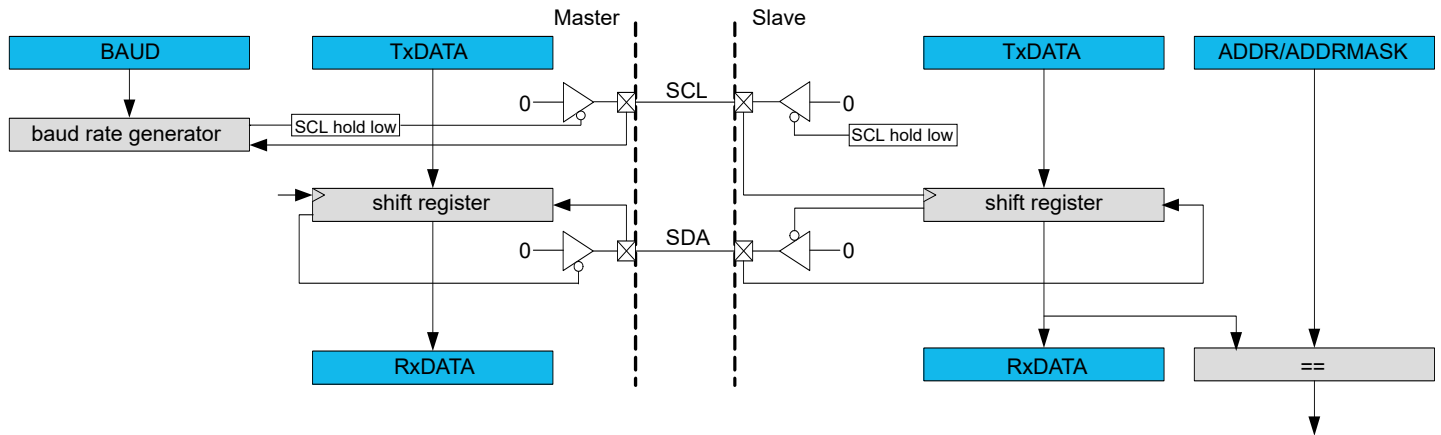
- Master or Slave Operation
- Can be used with DMA
- Philips I<sup>2</sup>C Compatible
- SMBus Compatible
- PMBus™ Compatible
- Support of 100 kHz and 400 kHz, 1 MHz and 3.4 MHz I<sup>2</sup>C mode
- 32-bit Data Extension for better system bus utilization
- 4-Wire Operation Supported
- Physical interface includes:
  - Slew-rate limited outputs
  - Filtered inputs
- Slave Operation:
  - Operation in all Sleep modes
  - Wake-up on address match
  - 7-bit and 10-bit Address match in hardware for:
    - Unique address and/or 7-bit general call address
    - Address range
    - Two unique addresses can be used with DMA

#### Related Links

[33.2 Features](#)

### 36.3 Block Diagram

Figure 36-1. I<sup>2</sup>C Single-Master Single-Slave Interconnection



### 36.4 Signal Description

Signal Name	Type	Description
PAD[0]	Digital I/O	SDA
PAD[1]	Digital I/O	SCL
PAD[2]	Digital I/O	SDA_OUT (4-wire operation)
PAD[3]	Digital I/O	SCL_OUT (4-wire operation)

One signal can be mapped on several pins.

Not all the pins are I<sup>2</sup>C pins. Refer to [SERCOM I2C Configurations](#) table for additional information.

#### Related Links

- [6. I/O Multiplexing and Considerations](#)
- [6.2.6 SERCOM I2C Configurations](#)
- [36.6.3.3 4-Wire Mode](#)

### 36.5 Product Dependencies

In order to use this peripheral, other parts of the system must be configured correctly, as described below.

#### 36.5.1 I/O Lines

In order to use the I/O lines of this peripheral, the I/O pins must be configured using the I/O Pin Controller (PORT).

When the SERCOM is used in I<sup>2</sup>C mode, the SERCOM controls the direction and value of the I/O pins. In I<sup>2</sup>C mode pull-up resistors are disabled. External pull-up resistors are required for proper function.

#### Related Links

- [32. PORT - I/O Pin Controller](#)

### 36.5.2 Power Management

This peripheral can continue to operate in any Sleep mode where its source clock is running. The interrupts can wake-up the device from Sleep modes.

#### Related Links

[18. PM – Power Manager](#)

### 36.5.3 Clocks

The SERCOM bus clock (CLK\_SERCOMx\_APB) can be enabled and disabled in the Main Clock Controller. Refer to *Peripheral Clock Masking* for details and default status of this clock.

Two generic clocks are used by SERCOM, GCLK\_SERCOMx\_CORE and GCLK\_SERCOM\_SLOW. The core clock (GCLK\_SERCOMx\_CORE) can clock the I<sup>2</sup>C when working as a master. The slow clock (GCLK\_SERCOM\_SLOW) is required only for certain functions, e.g. SMBus timing. These two clocks must be configured and enabled in the Generic Clock Controller (GCLK) before using the I<sup>2</sup>C.

These generic clocks are asynchronous to the bus clock (CLK\_SERCOMx\_APB). Due to this asynchronicity, writes to certain registers will require synchronization between the clock domains. Refer to [36.6.6 Synchronization](#) for further details.

#### Related Links

[14. GCLK - Generic Clock Controller](#)

[15.6.2.6 Peripheral Clock Masking](#)

[18. PM – Power Manager](#)

### 36.5.4 DMA

The DMA request lines are connected to the DMA Controller (DMAC). In order to use DMA requests with this peripheral the DMAC must be configured first. Refer to *DMAC – Direct Memory Access Controller* for details.

#### Related Links

[22. DMAC – Direct Memory Access Controller](#)

### 36.5.5 Interrupts

The interrupt request line is connected to the Interrupt Controller. In order to use interrupt requests of this peripheral, the Interrupt Controller (NVIC) must be configured first. Refer to *Nested Vector Interrupt Controller* for details.

#### Related Links

[10.2 Nested Vector Interrupt Controller](#)

### 36.5.6 Events

Not applicable.

### 36.5.7 Debug Operation

When the CPU is halted in Debug mode, this peripheral will continue normal operation. If the peripheral is configured to require periodical service by the CPU through interrupts or similar, improper operation or data loss may result during debugging. This peripheral can be forced to halt operation during debugging - refer to the Debug Control (DBGCTRL) register for details.

### 36.5.8 Register Access Protection

Registers with write access can be write-protected optionally by the Peripheral Access Controller (PAC).

PAC write protection is not available for the following registers:

- Interrupt Flag Clear and Status register (INTFLAG)
- Status register (STATUS)
- Data register (DATA)
- Address register (ADDR)

Optional PAC write protection is denoted by the "PAC Write-Protection" property in each individual register description.

Write-protection does not apply to accesses through an external debugger.

### Related Links

[27. PAC - Peripheral Access Controller](#)

### 36.5.9 Analog Connections

Not applicable.

## 36.6 Functional Description

### 36.6.1 Principle of Operation

The I<sup>2</sup>C interface uses two physical lines for communication:

- Serial Data Line (SDA) for data transfer
- Serial Clock Line (SCL) for the bus clock

A transaction starts with the I<sup>2</sup>C master sending the Start condition, followed by a 7-bit address and a direction bit (read or write to/from the slave).

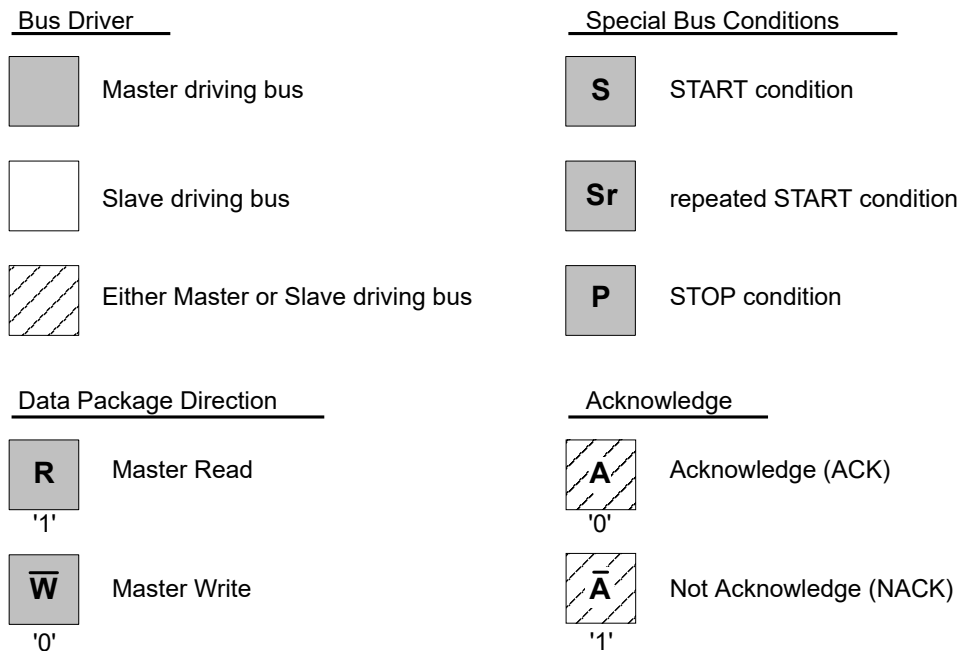
The addressed I<sup>2</sup>C slave will then Acknowledge (ACK) the address, and data packet transactions can begin. Every 9-bit data packet consists of 8 data bits followed by a one-bit reply indicating whether the data was acknowledged or not.

If a data packet is Not Acknowledged (NACK), whether by the I<sup>2</sup>C slave or master, the I<sup>2</sup>C master takes action by either terminating the transaction by sending the Stop condition, or by sending a repeated start to transfer more data.

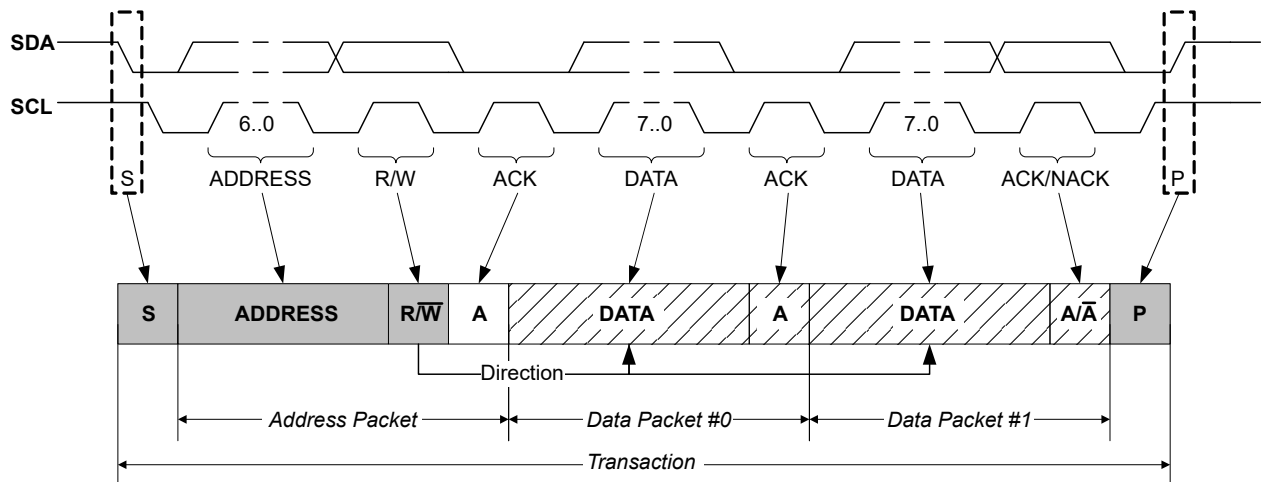
The figure below illustrates the possible transaction formats and [Transaction Diagram Symbols](#) explains the transaction symbols. These symbols will be used in the following descriptions.



**Figure 36-2. Transaction Diagram Symbols**



**Figure 36-3. Basic I<sup>2</sup>C Transaction Diagram**



## 36.6.2 Basic Operation

### 36.6.2.1 Initialization

The following registers are enable-protected, meaning they can be written only when the I<sup>2</sup>C interface is disabled (CTRLA.ENABLE is '0'):

- Control A register (CTRLA), except Enable (CTRLA.ENABLE) and Software Reset (CTRLA.SWRST) bits
- Control B register (CTRLB), except Acknowledge Action (CTRLB.ACKACT) and Command (CTRLB.CMD) bits
- Baud register (BAUD)
- Address register (ADDR) in slave operation.

When the I<sup>2</sup>C is enabled or is being enabled (CTRLA.ENABLE=1), writing to these registers will be discarded. If the I<sup>2</sup>C is being disabled, writing to these registers will be completed after the disabling.

Enable-protection is denoted by the "Enable-Protection" property in the register description.

Before the I<sup>2</sup>C is enabled it must be configured as outlined by the following steps:

1. Select I<sup>2</sup>C Master or Slave mode by writing 0x4 (Slave mode) or 0x5 (Master mode) to the Operating Mode bits in the CTRLA register (CTRLA.MODE).
2. If desired, select the SDA Hold Time value in the CTRLA register (CTRLA.SDAHOLD).
3. In Slave mode, the minimum slave setup time for the SDA can be selected in the SDA Setup Time bit group in the Control C register (CTRLC.SDASETUP).
4. If desired, enable smart operation by setting the Smart Mode Enable bit in the CTRLB register (CTRLB.SMEN).
5. If desired, enable SCL low time-out by setting the SCL Low Time-Out bit in the Control A register (CTRLA.LOWTOUT).
6. In Master mode:
  - 6.1. Select the inactive bus time-out in the Inactive Time-Out bit group in the CTRLA register (CTRLA.INACTOUT).
  - 6.2. Write the Baud Rate register (BAUD) to generate the desired baud rate.

In Slave mode:

- 6.1. Configure the address match configuration by writing the Address Mode value in the CTRLB register (CTRLB.AMODE).
- 6.2. Set the Address and Address Mask value in the Address register (ADDR.ADDR and ADDR.ADDRMASK) according to the address configuration.

### 36.6.2.2 Enabling, Disabling, and Resetting

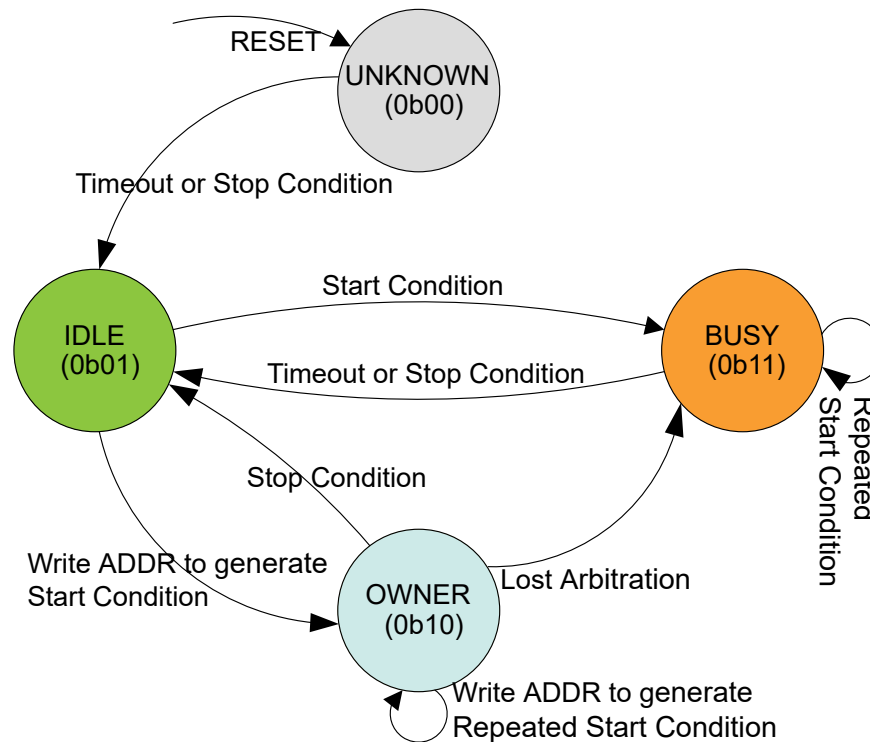
This peripheral is enabled by writing '1' to the Enable bit in the Control A register (CTRLA.ENABLE), and disabled by writing '0' to it.

Writing '1' to the Software Reset bit in the Control A register (CTRLA.SWRST) will reset all registers of this peripheral to their initial states, except the DBGCTRL register, and the peripheral is disabled.

### 36.6.2.3 I<sup>2</sup>C Bus State Logic

The Bus state logic includes several logic blocks that continuously monitor the activity on the I<sup>2</sup>C bus lines in all Sleep modes with running GCLK\_SERCOM\_x clocks. The start and stop detectors and the bit counter are all essential in the process of determining the current Bus state. The Bus state is determined according to [Bus State Diagram](#). Software can get the current Bus state by reading the Master Bus State bits in the Status register (STATUS.BUSSTATE). The value of STATUS.BUSSTATE in the figure is shown in binary.

**Figure 36-4. Bus State Diagram**



The Bus state machine is active when the I<sup>2</sup>C master is enabled.

After the I<sup>2</sup>C master has been enabled, the Bus state is UNKNOWN (0b00). From the UNKNOWN state, the bus will transition to IDLE (0b01) by either:

- Forcing by writing 0b01 to STATUS.BUSSTATE
- A Stop condition is detected on the bus
- If the inactive bus time-out is configured for SMBus compatibility (CTRLA.INACTOUT) and a time-out occurs.

**Note:** Once a known Bus state is established, the Bus state logic will not re-enter the UNKNOWN state.

When the bus is IDLE it is ready for a new transaction. If a Start condition is issued on the bus by another I<sup>2</sup>C master in a multi-master setup, the bus becomes BUSY (0b11). The bus will re-enter IDLE either when a Stop condition is detected, or when a time-out occurs (inactive bus time-out needs to be configured).

If a Start condition is generated internally by writing the Address bit group in the Address register (ADDR.ADDR) while IDLE, the OWNER state (0b10) is entered. If the complete transaction was performed without interference, i.e., arbitration was not lost, the I<sup>2</sup>C master can issue a Stop condition, which will change the Bus state back to IDLE.

However, if a packet collision is detected while in OWNER state, the arbitration is assumed lost and the Bus state becomes BUSY until a Stop condition is detected. A repeated Start condition will change the Bus state only if arbitration is lost while issuing a repeated start.

**Note:** Violating the protocol may cause the I<sup>2</sup>C to hang. If this happens it is possible to recover from this state by a software Reset (CTRLA.SWRST='1').

### Related Links

[36.10.1 CTRLA](#)

### 36.6.2.4 I<sup>2</sup>C Master Operation

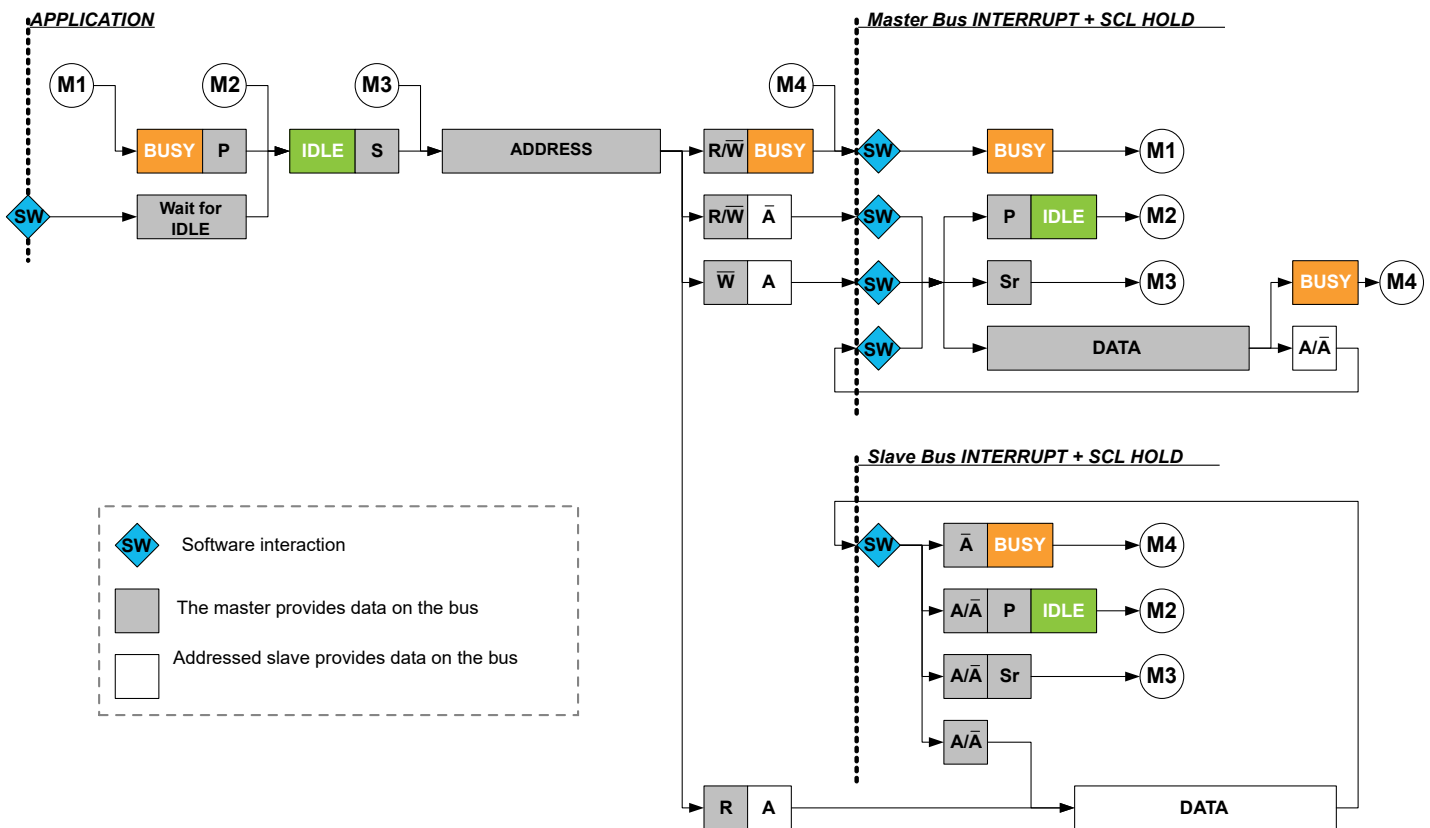
The I<sup>2</sup>C master is byte-oriented and interrupt based. The number of interrupts generated is kept at a minimum by automatic handling of most incidents. The software driver complexity and code size are reduced by auto-triggering of operations, and a Special Smart mode, which can be enabled by the Smart Mode Enable bit in the Control A register (CTRLA.SMEN).

The I<sup>2</sup>C master has two interrupt strategies.

When SCL Stretch Mode (CTRLA.SCLSM) is '0', SCL is stretched before or after the Acknowledge bit. In this mode the I<sup>2</sup>C master operates according to [Master Behavioral Diagram \(SCLSM=0\)](#). The circles labeled "Mn" (M1, M2..) indicate the nodes the bus logic can jump to, based on software or hardware interaction.

This diagram is used as reference for the description of the I<sup>2</sup>C master operation throughout the document.

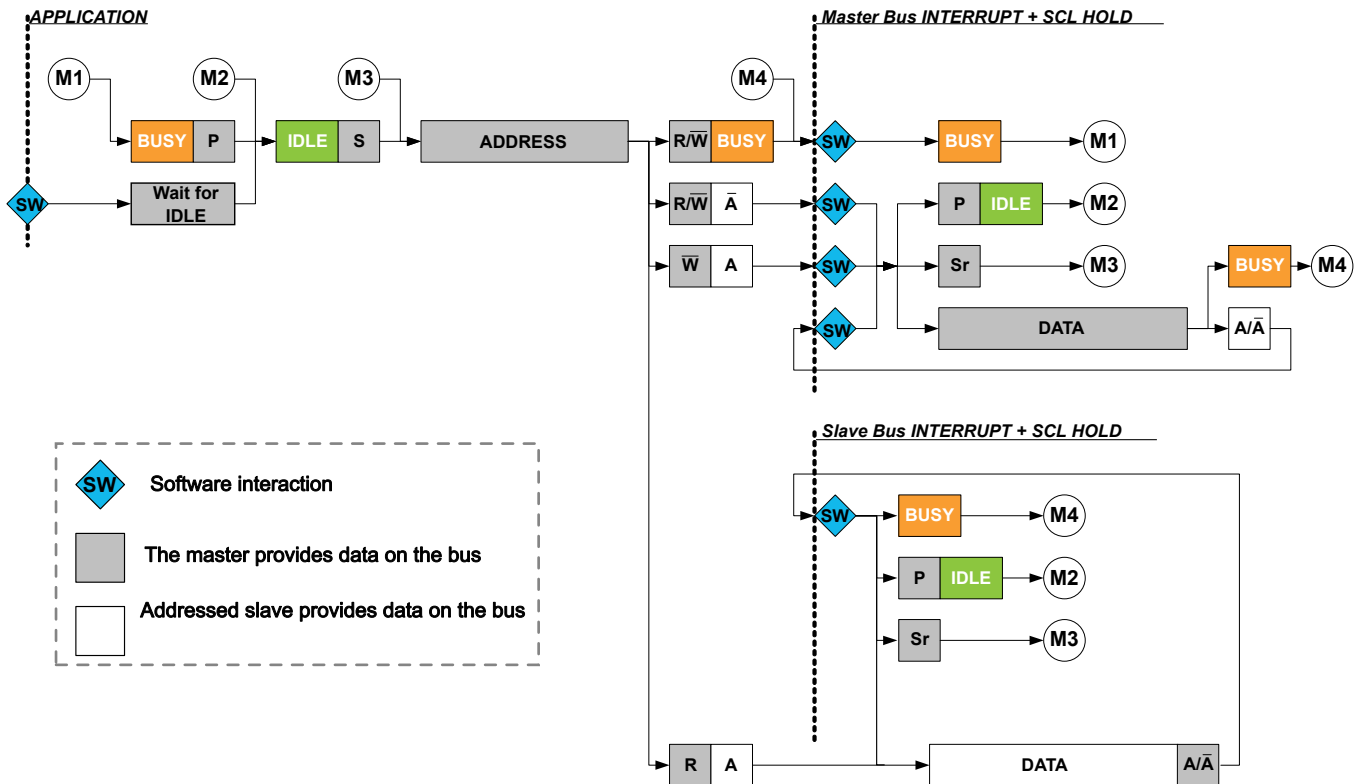
**Figure 36-5. I<sup>2</sup>C Master Behavioral Diagram (SCLSM=0)**



In the second strategy (CTRLA.SCLSM=1), interrupts only occur after the ACK bit, as in [Master Behavioral Diagram \(SCLSM=1\)](#). This strategy can be used when it is not necessary to check DATA before acknowledging.

**Note:** I<sup>2</sup>C High-speed (*Hs*) mode requires CTRLA.SCLSM=1.

**Figure 36-6. I<sup>2</sup>C Master Behavioral Diagram (SCLSM=1)**



### 36.6.2.4.1 Master Clock Generation

The SERCOM peripheral supports several I<sup>2</sup>C bidirectional modes:

- Standard mode (*Sm*) up to 100 kHz
- Fast mode (*Fm*) up to 400 kHz
- Fast mode Plus (*Fm+*) up to 1 MHz
- High-speed mode (*Hs*) up to 3.4 MHz

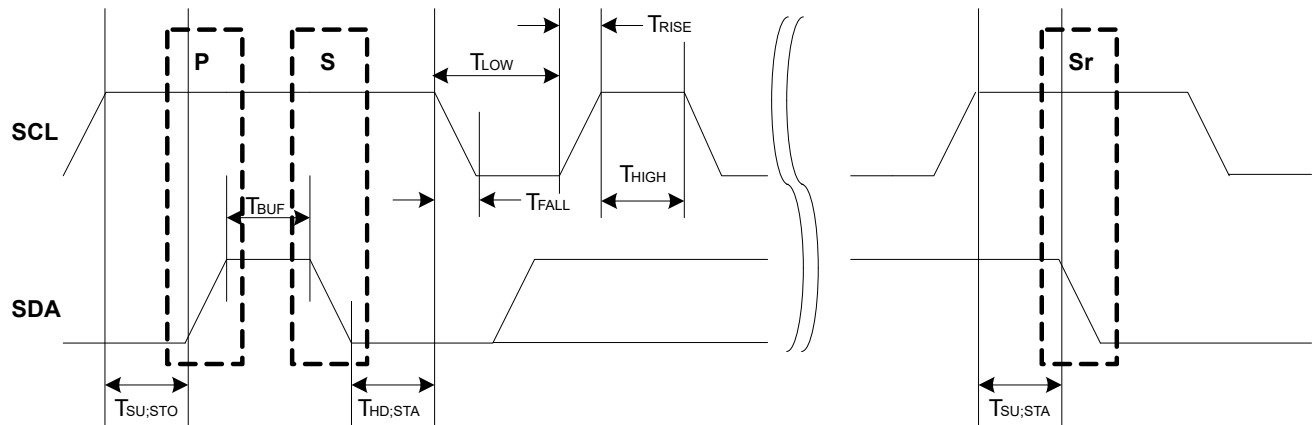
The Master clock configuration for *Sm*, *Fm*, and *Fm+* are described in [Clock Generation \(Standard-Mode, Fast-Mode, and Fast-Mode Plus\)](#). For *Hs*, refer to [Master Clock Generation \(High-Speed Mode\)](#).

#### **Clock Generation (Standard-Mode, Fast-Mode, and Fast-Mode Plus)**

In I<sup>2</sup>C *Sm*, *Fm*, and *Fm+* mode, the Master clock (SCL) frequency is determined as described in this section:

The low ( $T_{LOW}$ ) and high ( $T_{HIGH}$ ) times are determined by the Baud Rate register (BAUD), while the rise ( $T_{RISE}$ ) and fall ( $T_{FALL}$ ) times are determined by the bus topology. Because of the wired-AND logic of the bus,  $T_{FALL}$  will be considered as part of  $T_{LOW}$ . Likewise,  $T_{RISE}$  will be in a state between  $T_{LOW}$  and  $T_{HIGH}$  until a high state has been detected.

**Figure 36-7. SCL Timing**



The following parameters are timed using the SCL low time period  $T_{LOW}$ . This comes from the Master Baud Rate Low bit group in the Baud Rate register (BAUD.BAUDLOW). When BAUD.BAUDLOW=0, or the Master Baud Rate bit group in the Baud Rate register (BAUD.BAUD) determines it.

- $T_{LOW}$  – Low period of SCL clock
- $T_{SU;STO}$  – Set-up time for stop condition
- $T_{BUF}$  – Bus free time between stop and start conditions
- $T_{HD;STA}$  – Hold time (repeated) start condition
- $T_{SU;STA}$  – Set-up time for repeated start condition
- $T_{HIGH}$  is timed using the SCL high time count from BAUD.BAUD
- $T_{RISE}$  is determined by the bus impedance; for internal pull-ups.
- $T_{FALL}$  is determined by the open-drain current limit and bus impedance; can typically be regarded as zero.

The SCL frequency is given by:

$$f_{SCL} = \frac{1}{T_{LOW} + T_{HIGH} + T_{RISE}}$$

When BAUD.BAUDLOW is zero, the BAUD.BAUD value is used to time both SCL high and SCL low. In this case the following formula will give the SCL frequency:

$$f_{SCL} = \frac{f_{GCLK}}{10 + 2BAUD + f_{GCLK} \cdot T_{RISE}}$$

When BAUD.BAUDLOW is non-zero, the following formula determines the SCL frequency:

$$f_{SCL} = \frac{f_{GCLK}}{10 + BAUD + BAUDLOW + f_{GCLK} \cdot T_{RISE}}$$

The following formulas can determine the SCL  $T_{LOW}$  and  $T_{HIGH}$  times:

$$T_{LOW} = \frac{BAUDLOW + 5}{f_{GCLK}}$$

$$T_{HIGH} = \frac{BAUD + 5}{f_{GCLK}}$$

**Note:** The I<sup>2</sup>C standard *Fm+* (Fast-mode plus) requires a nominal high to low SCL ratio of 1:2, and BAUD should be set accordingly. At a minimum, BAUD.BAUD and/or BAUD.BAUDLOW must be non-zero.

**Startup Timing** The minimum time between SDA transition and SCL rising edge is 6 APB cycles when the DATA register is written in smart mode. If a greater startup time is required due to long rise times, the time between DATA write and IF clear must be controlled by software.

**Note:** When timing is controlled by user, the Smart Mode cannot be enabled.

### **Master Clock Generation (High-Speed Mode)**

For I<sup>2</sup>C *Hs* transfers, there is no SCL synchronization. Instead, the SCL frequency is determined by the GCLK\_SERCOMx\_CORE frequency ( $f_{GCLK}$ ) and the High-Speed Baud setting in the Baud register (BAUD.HSBAUD). When BAUD.HSBAUDLOW=0, the HSBAUD value will determine both SCL high and SCL low. In this case the following formula determines the SCL frequency.

$$f_{SCL} = \frac{f_{GCLK}}{2 + 2 \cdot HS\ BAUD}$$

When HSBAUDLOW is non-zero, the following formula determines the SCL frequency.

$$f_{SCL} = \frac{f_{GCLK}}{2 + HS\ BAUD + HSBAUDLOW}$$

**Note:** The I<sup>2</sup>C standard *Hs* (High-speed) requires a nominal high to low SCL ratio of 1:2, and HSBAUD should be set accordingly. At a minimum, BAUD.HSBAUD and/or BAUD.HSBAUDLOW must be non-zero.

#### **36.6.2.4.2 Transmitting Address Packets**

The I<sup>2</sup>C master starts a bus transaction by writing the I<sup>2</sup>C slave address to ADDR.ADDR and the direction bit, as described in [36.6.1 Principle of Operation](#). If the bus is busy, the I<sup>2</sup>C master will wait until the bus becomes idle before continuing the operation. When the bus is idle, the I<sup>2</sup>C master will issue a start condition on the bus. The I<sup>2</sup>C master will then transmit an address packet using the address written to ADDR.ADDR. After the address packet has been transmitted by the I<sup>2</sup>C master, one of four cases will arise according to arbitration and transfer direction.

#### **Case 1: Arbitration lost or bus error during address packet transmission**

If arbitration was lost during transmission of the address packet, the Master on Bus bit in the Interrupt Flag Status and Clear register (INTFLAG.MB) and the Arbitration Lost bit in the Status register (STATUS.ARBLOST) are both set. Serial data output to SDA is disabled, and the SCL is released, which disables clock stretching. In effect the I<sup>2</sup>C master is no longer allowed to execute any operation on the bus until the bus is idle again. A bus error will behave similarly to the Arbitration Lost condition. In this case, the MB Interrupt flag and Master Bus Error bit in the Status register (STATUS.BUSERR) are both set in addition to STATUS.ARBLOST.

The Master Received Not Acknowledge bit in the Status register (STATUS.RXNACK) will always contain the last successfully received acknowledge or not acknowledge indication.

In this case, software will typically inform the application code of the condition and then clear the Interrupt flag before exiting the interrupt routine. No other flags have to be cleared at this moment, because all flags will be cleared automatically the next time the ADDR.ADDR register is written.

#### **Case 2: Address packet transmit complete – No ACK received**

If there is no I<sup>2</sup>C slave device responding to the address packet, then the INTFLAG.MB Interrupt flag and STATUS.RXNACK will be set. The clock hold is active at this point, preventing further activity on the bus.

The missing ACK response can indicate that the I<sup>2</sup>C slave is busy with other tasks or sleeping. Therefore, it is not able to respond. In this event, the next step can be either issuing a Stop condition (recommended) or resending the address packet by a repeated Start condition. When using SMBus logic, the slave must ACK the address. If there is no response, it means that the slave is not available on the bus.

### Case 3: Address packet transmit complete – Write packet, Master on Bus set

If the I<sup>2</sup>C master receives an acknowledge response from the I<sup>2</sup>C slave, INTFLAG.MB will be set and STATUS.RXNACK will be cleared. The clock hold is active at this point, preventing further activity on the bus.

In this case, the software implementation becomes highly protocol dependent. Three possible actions can enable the I<sup>2</sup>C operation to continue:

- Initiate a data transmit operation by writing the data byte to be transmitted into DATA.DATA.
- Transmit a new address packet by writing ADDR.ADDR. A repeated Start condition will automatically be inserted before the address packet.
- Issue a Stop condition, consequently terminating the transaction.

### Case 4: Address packet transmit complete – Read packet, Slave on Bus set

If the I<sup>2</sup>C master receives an ACK from the I<sup>2</sup>C slave, the I<sup>2</sup>C master proceeds to receive the next byte of data from the I<sup>2</sup>C slave. When the first data byte is received, the Slave on Bus bit in the Interrupt Flag register (INTFLAG.SB) will be set and STATUS.RXNACK will be cleared. The clock hold is active at this point, preventing further activity on the bus.

In this case, the software implementation becomes highly protocol dependent. Three possible actions can enable the I<sup>2</sup>C operation to continue:

- Let the I<sup>2</sup>C master continue to read data by acknowledging the data received. ACK can be sent by software, or automatically in Smart mode.
- Transmit a new address packet.
- Terminate the transaction by issuing a Stop condition.

**Note:** An ACK or NACK will be automatically transmitted if Smart mode is enabled. The Acknowledge Action bit in the Control B register (CTRLB.ACKACT) determines whether ACK or NACK should be sent.

#### 36.6.2.4.3 Transmitting Data Packets

When an address packet with direction Master Write (see [Figure 36-3](#)) was transmitted successfully, INTFLAG.MB will be set. The I<sup>2</sup>C master will start transmitting data via the I<sup>2</sup>C bus by writing to DATA.DATA, and monitor continuously for packet collisions.

If a collision is detected, the I<sup>2</sup>C master will lose arbitration and STATUS.ARBLOST will be set. If the transmit was successful, the I<sup>2</sup>C master will receive an ACK bit from the I<sup>2</sup>C slave, and STATUS.RXNACK will be cleared. INTFLAG.MB will be set in both cases, regardless of arbitration outcome.

It is recommended to read STATUS.ARBLOST and handle the arbitration lost condition in the beginning of the I<sup>2</sup>C Master on Bus interrupt. This can be done as there is no difference between handling address and data packet arbitration.

STATUS.RXNACK must be checked for each data packet transmitted before the next data packet transmission can commence. The I<sup>2</sup>C master is not allowed to continue transmitting data packets if a NACK is received from the I<sup>2</sup>C slave.



### 36.6.2.4.4 Receiving Data Packets (SCLSM=0)

When INTFLAG.SB is set, the I<sup>2</sup>C master will already have received one data packet. The I<sup>2</sup>C master must respond by sending either an ACK or NACK. Sending a NACK may be unsuccessful when arbitration is lost during the transmission. In this case, a lost arbitration will prevent setting INTFLAG.SB. Instead, INTFLAG.MB will indicate a change in arbitration. Handling of lost arbitration is the same as for data bit transmission.

### 36.6.2.4.5 Receiving Data Packets (SCLSM=1)

When INTFLAG.SB is set, the I<sup>2</sup>C master will already have received one data packet and transmitted an ACK or NACK, depending on CTRLB.ACKACT. At this point, CTRLB.ACKACT must be set to the correct value for the next ACK bit, and the transaction can continue by reading DATA and issuing a command if not in the Smart mode.

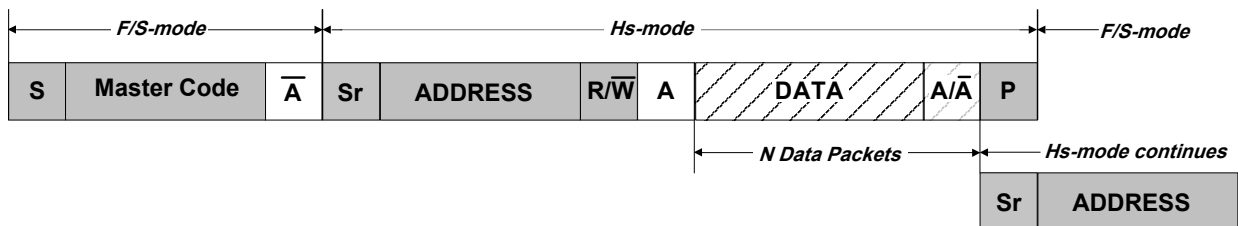
### 36.6.2.4.6 High-Speed Mode

High-speed transfers are a multi-step process, see [High Speed Transfer](#).

First, a master code (0b00001nnn, where 'nnn' is a unique master code) is transmitted in Full-speed mode, followed by a NACK since no slaves should acknowledge. Arbitration is performed only during the Full-speed Master Code phase. The master code is transmitted by writing the master code to the Address register (ADDR.ADDR) and writing the High-speed bit (ADDR.HS) to '0'.

After the master code and NACK have been transmitted, the master write interrupt will be asserted. In the meanwhile, the slave address can be written to the ADDR.ADDR register together with ADDR.HS=1. Now in High-speed mode, the master will generate a repeated start, followed by the slave address with RW-direction. The bus will remain in High-speed mode until a stop is generated. If a repeated start is desired, the ADDR.HS bit must again be written to '1', along with the new address ADDR.ADDR to be transmitted.

**Figure 36-8. High Speed Transfer**



Transmitting in High-speed mode requires the I<sup>2</sup>C master to be configured in High-speed mode (CTRLA.SPEED=0x2) and the SCL Clock Stretch mode (CTRLA.SCLSM) bit set to '1'.

### 36.6.2.4.7 10-Bit Addressing

When 10-bit addressing is enabled by the Ten Bit Addressing Enable bit in the Address register (ADDR.TENBITEN=1) and the Address bit field ADDR.ADDR is written, the two address bytes will be transmitted, see [10-bit Address Transmission for a Read Transaction](#). The addressed slave acknowledges the two address bytes, and the transaction continues. Regardless of whether the transaction is a read or write, the master must start by sending the 10-bit address with the direction bit (ADDR.ADDR[0]) being zero.

If the master receives a NACK after the first byte, the Write Interrupt flag will be raised and the STATUS.RXNACK bit will be set. If the first byte is acknowledged by one or more slaves, then the master will proceed to transmit the second address byte and the master will first see the Write Interrupt flag after the second byte is transmitted. If the transaction direction is read-from-slave, the 10-bit address transmission must be followed by a repeated start and the first 7 bits of the address with the read/write bit equal to '1'.

**Figure 36-9. 10-bit Address Transmission for a Read Transaction**



This implies the following procedure for a 10-bit read operation:

1. Write the 10-bit address to ADDR.ADDR[10:1]. ADDR.TENBITEN must be '1', the direction bit (ADDR.ADDR[0]) must be '0' (can be written simultaneously with ADDR).
2. Once the Master on Bus interrupt is asserted, Write ADDR[7:0] register to '11110 address [9:8] 1'. ADDR.TENBITEN must be cleared (can be written simultaneously with ADDR).
3. Proceed to transmit data.

### 36.6.2.5 I<sup>2</sup>C Slave Operation

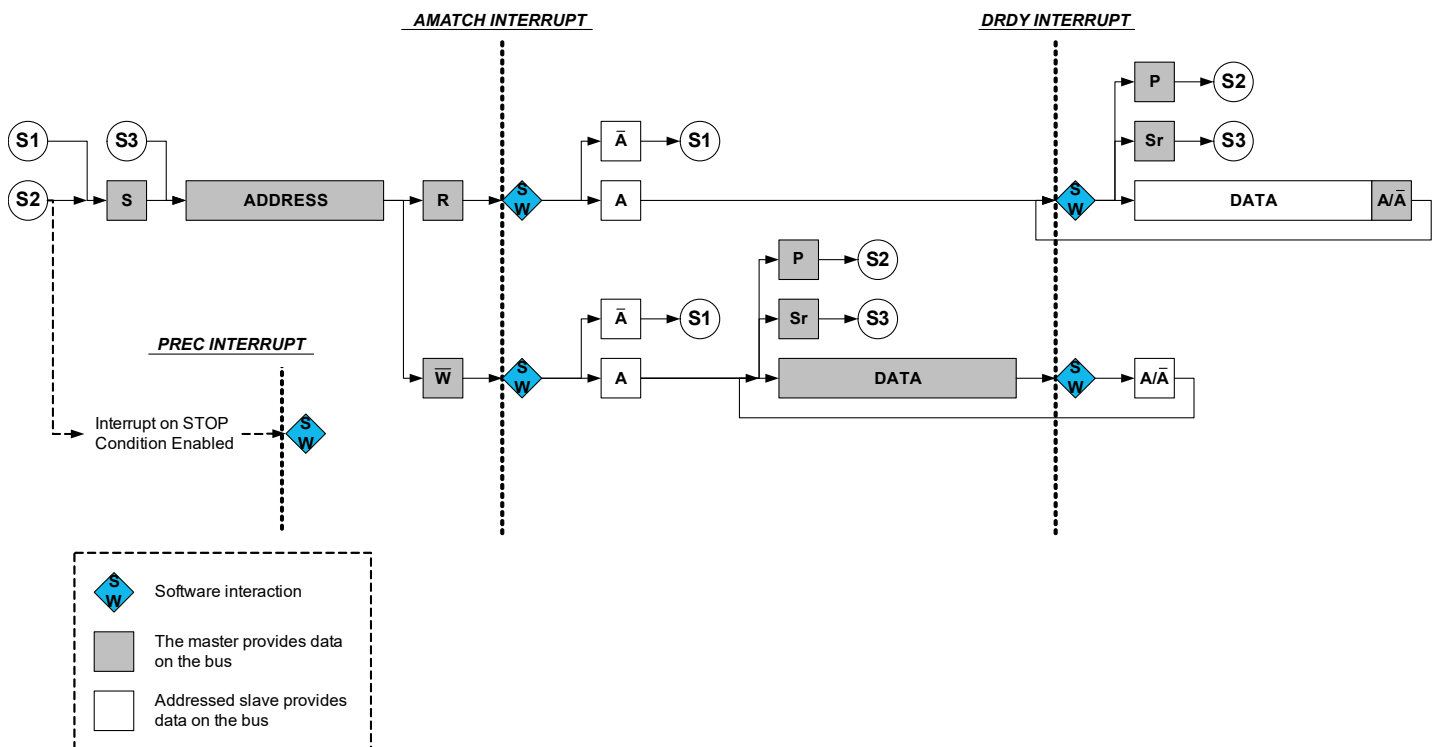
The I<sup>2</sup>C slave is byte-oriented and interrupt-based. The number of interrupts generated is kept at a minimum by automatic handling of most events. The software driver complexity and code size are reduced by auto-triggering of operations, and a special smart mode, which can be enabled by the Smart Mode Enable bit in the Control A register (CTRLA.SMEN).

The I<sup>2</sup>C slave has two interrupt strategies.

When SCL Stretch Mode bit (CTRLA.SCLSM) is '0', SCL is stretched before or after the acknowledge bit. In this mode, the I<sup>2</sup>C slave operates according to [I<sup>2</sup>C Slave Behavioral Diagram \(SCLSM=0\)](#). The circles labelled "Sn" (S1, S2..) indicate the nodes the bus logic can jump to, based on software or hardware interaction.

This diagram is used as reference for the description of the I<sup>2</sup>C slave operation throughout the document.

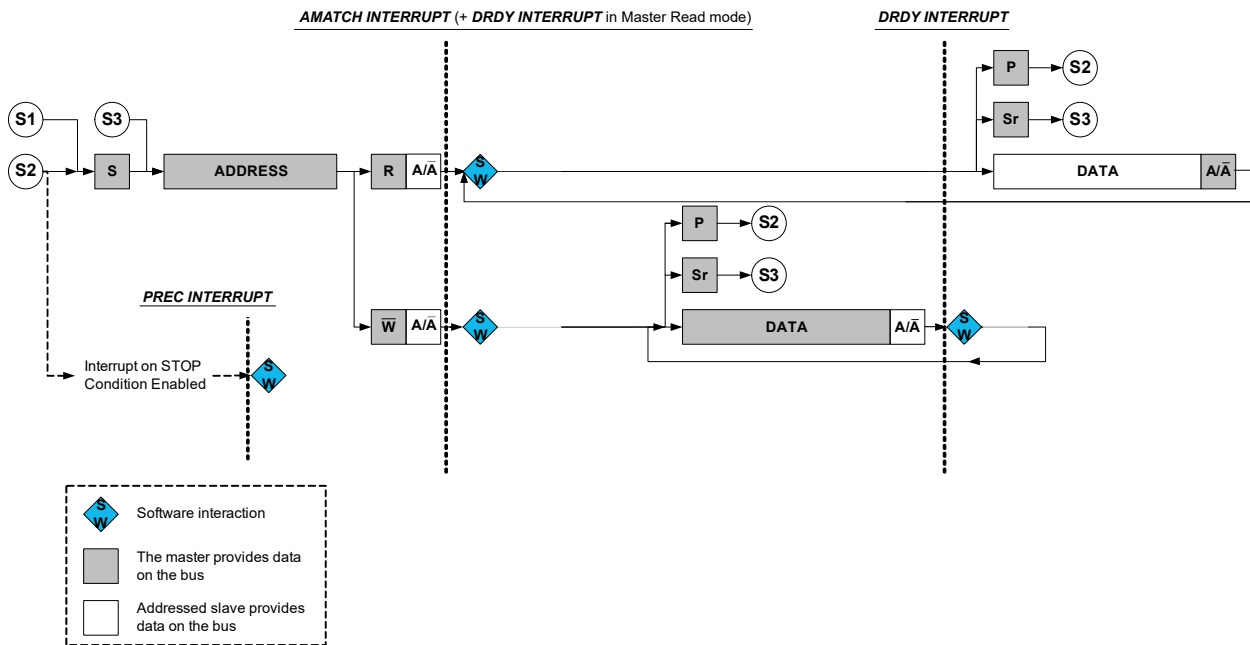
**Figure 36-10. I<sup>2</sup>C Slave Behavioral Diagram (SCLSM=0)**



In the second strategy (CTRLA.SCLSM=1), interrupts only occur after the ACK bit is sent as shown in [Slave Behavioral Diagram \(SCLSM=1\)](#). This strategy can be used when it is not necessary to check DATA before acknowledging. For master reads, an address and data interrupt will be issued simultaneously after the address acknowledge. However, for master writes, the first data interrupt will be seen after the first data byte has been received by the slave and the acknowledge bit has been sent to the master.

**Note:** For I<sup>2</sup>C High-speed mode (*Hs*), SCLSM=1 is required.

**Figure 36-11. I<sup>2</sup>C Slave Behavioral Diagram (SCLSM=1)**



### 36.6.2.5.1 Receiving Address Packets (SCLSM=0)

When CTRLA.SCLSM=0, the I<sup>2</sup>C slave stretches the SCL line according to [Figure 36-10](#). When the I<sup>2</sup>C slave is properly configured, it will wait for a Start condition.

When a Start condition is detected, the successive address packet will be received and checked by the address match logic. If the received address is not a match, the packet will be rejected, and the I<sup>2</sup>C slave will wait for a new Start condition. If the received address is a match, the Address Match bit in the Interrupt Flag register (INTFLAG.AMATCH) will be set.

SCL will be stretched until the I<sup>2</sup>C slave clears INTFLAG.AMATCH. As the I<sup>2</sup>C slave holds the clock by forcing SCL low, the software has unlimited time to respond.

The direction of a transaction is determined by reading the Read/Write Direction bit in the Status register (STATUS.DIR). This bit will be updated only when a valid address packet is received.

If the Transmit Collision bit in the Status register (STATUS.COLL) is set, this indicates that the last packet addressed to the I<sup>2</sup>C slave had a packet collision. A collision causes the SDA and SCL lines to be released without any notification to software. Therefore, the next AMATCH interrupt is the first indication of the previous packet's collision. Collisions are intended to follow the SMBus Address Resolution Protocol (ARP).

After the address packet has been received from the I<sup>2</sup>C master, one of two cases will arise based on transfer direction.

### Case 1: Address packet accepted – Read flag set

The STATUS.DIR bit is '1', indicating an I<sup>2</sup>C master read operation. The SCL line is forced low, stretching the bus clock. If an ACK is sent, I<sup>2</sup>C slave hardware will set the Data Ready bit in the Interrupt Flag register (INTFLAG.DRDY), indicating data are needed for transmit. If a NACK is sent, the I<sup>2</sup>C slave will wait for a new Start condition and address match.

Typically, software will immediately acknowledge the address packet by sending an ACK/NACK bit. The I<sup>2</sup>C slave Command bit field in the Control B register (CTRLB.CMD) can be written to '0x3' for both read and write operations as the command execution is dependent on the STATUS.DIR bit. Writing '1' to INTFLAG.AMATCH will also cause an ACK/NACK to be sent corresponding to the CTRLB.ACKACT bit.

### Case 2: Address packet accepted – Write flag set

The STATUS.DIR bit is cleared, indicating an I<sup>2</sup>C master write operation. The SCL line is forced low, stretching the bus clock. If an ACK is sent, the I<sup>2</sup>C slave will wait for data to be received. Data, repeated start or stop can be received.

If a NACK is sent, the I<sup>2</sup>C slave will wait for a new Start condition and address match. Typically, software will immediately acknowledge the address packet by sending an ACK/NACK. The I<sup>2</sup>C slave command CTRLB.CMD = 3 can be used for both read and write operation as the command execution is dependent on STATUS.DIR.

Writing '1' to INTFLAG.AMATCH will also cause an ACK/NACK to be sent corresponding to the CTRLB.ACKACT bit.

#### 36.6.2.5.2 Receiving Address Packets (SCLSM=1)

When SCLSM=1, the I<sup>2</sup>C slave will stretch the SCL line only after an ACK, see [Slave Behavioral Diagram \(SCLSM=1\)](#). When the I<sup>2</sup>C slave is properly configured, it will wait for a Start condition to be detected.

When a Start condition is detected, the successive address packet will be received and checked by the address match logic.

If the received address is not a match, the packet will be rejected and the I<sup>2</sup>C slave will wait for a new Start condition.

If the address matches, the acknowledge action as configured by the Acknowledge Action bit Control B register (CTRLB.ACKACT) will be sent and the Address Match bit in the Interrupt Flag register (INTFLAG.AMATCH) is set. SCL will be stretched until the I<sup>2</sup>C slave clears INTFLAG.AMATCH. As the I<sup>2</sup>C slave holds the clock by forcing SCL low, the software is given unlimited time to respond to the address.

The direction of a transaction is determined by reading the Read/Write Direction bit in the Status register (STATUS.DIR). This bit will be updated only when a valid address packet is received.

If the Transmit Collision bit in the Status register (STATUS.COLL) is set, the last packet addressed to the I<sup>2</sup>C slave had a packet collision. A collision causes the SDA and SCL lines to be released without any notification to software. The next AMATCH interrupt is, therefore, the first indication of the previous packet's collision. Collisions are intended to follow the SMBus Address Resolution Protocol (ARP).

After the address packet has been received from the I<sup>2</sup>C master, INTFLAG.AMATCH be set to '1' to clear it.

#### 36.6.2.5.3 Receiving and Transmitting Data Packets

After the I<sup>2</sup>C slave has received an address packet, it will respond according to the direction either by waiting for the data packet to be received or by starting to send a data packet by writing to DATA.DATA.

When a data packet is received or sent, INTFLAG.DRDY will be set. After receiving data, the I<sup>2</sup>C slave will send an acknowledge according to CTRLB.ACKACT.

### Case 1: Data received

INTFLAG.DRDY is set, and SCL is held low, pending for SW interaction.

### Case 2: Data sent

When a byte transmission is successfully completed, the INTFLAG.DRDY Interrupt flag is set. If NACK is received, indicated by STATUS.RXNACK=1, the I<sup>2</sup>C slave must expect a stop or a repeated start to be received. The I<sup>2</sup>C slave must release the data line to allow the I<sup>2</sup>C master to generate a stop or repeated start. Upon detecting a Stop condition, the Stop Received bit in the Interrupt Flag register (INTFLAG.PREC) will be set and the I<sup>2</sup>C slave will return to IDLE state.

#### 36.6.2.5.4 High-Speed Mode

When the I<sup>2</sup>C slave is configured in High-speed mode (*Hs*, CTRLA.SPEED=0x2) and CTRLA.SCLSM=1, switching between Full-speed and High-speed modes is automatic. When the slave recognizes a START followed by a master code transmission and a NACK, it automatically switches to High-speed mode and sets the High-speed status bit (STATUS.HS). The slave will then remain in High-speed mode until a STOP is received.

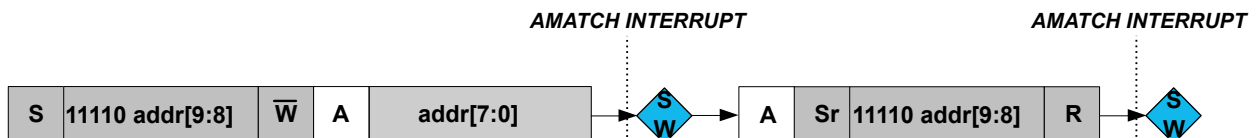
#### 36.6.2.5.5 10-Bit Addressing

When 10-bit addressing is enabled (ADDR.TENBITEN=1), the two address bytes following a START will be checked against the 10-bit slave address recognition. The first byte of the address will always be acknowledged, and the second byte will raise the address Interrupt flag, see [10-bit Addressing](#).

If the transaction is a write, then the 10-bit address will be followed by *N* data bytes.

If the operation is a read, the 10-bit address will be followed by a repeated START and reception of '11110 ADDR[9:8] 1', and the second address interrupt will be received with the DIR bit set. The slave matches on the second address as it was addressed by the previous 10-bit address.

**Figure 36-12. 10-bit Addressing**



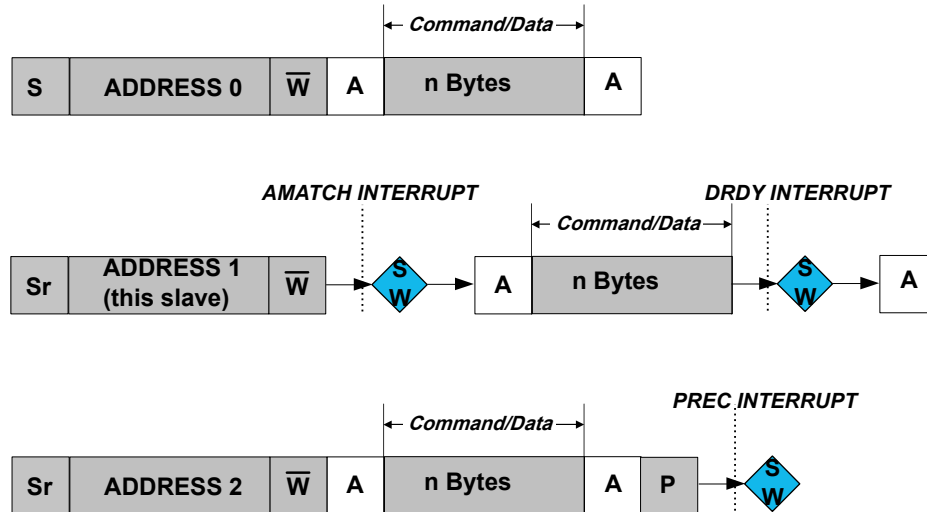
#### 36.6.2.5.6 PMBus Group Command

When the PMBus Group Command bit in the CTRLB register is set (CTRLB.GCMD=1) and 7-bit addressing is used, INTFLAG.PREC will be set if the slave has been addressed since the last STOP condition. When CTRLB.GCMD=0, a STOP condition without address match will not be set INTFLAG.PREC.

The group command protocol is used to send commands to more than one device. The commands are sent in one continuous transmission with a single STOP condition at the end. When the STOP condition is detected by the slaves addressed during the group command, they all begin executing the command they received.

[PMBus Group Command Example](#) shows an example where this slave, bearing ADDRESS 1, is addressed after a repeated START condition. There can be multiple slaves addressed before and after this slave. Eventually, at the end of the group command, a single STOP is generated by the master. At this point a STOP interrupt is asserted.

**Figure 36-13. PMBus Group Command Example**



### 36.6.3 Additional Features

#### 36.6.3.1 SMBus

The I<sup>2</sup>C includes three hardware SCL low time-outs, which allow a time-out to occur for SMBus SCL low time-out, master extend time-out, and slave extend time-out. This allows for SMBus functionality. These time-outs are driven by the GCLK\_SERCOM\_SLOW clock. The GCLK\_SERCOM\_SLOW clock is used to accurately time the time-out and must be configured to use a 32 KHz oscillator. The I<sup>2</sup>C interface also allows for a SMBus compatible SDA hold time.

- $T_{\text{TIMEOUT}}$ : SCL low time of 25..35ms – Measured for a single SCL low period. It is enabled by CTRLA.LOWTOUTEN.
- $T_{\text{LOW:SEXT}}$ : Cumulative clock low extend time of 25 ms – Measured as the cumulative SCL low extend time by a slave device in a single message from the initial START to the STOP. It is enabled by CTRLA.SEXTTOEN.
- $T_{\text{LOW:MEXT}}$ : Cumulative clock low extend time of 10 ms – Measured as the cumulative SCL low extend time by the master device within a single byte from START-to-ACK, ACK-to-ACK, or ACK-to-STOP. It is enabled by CTRLA.MEXTTOEN.

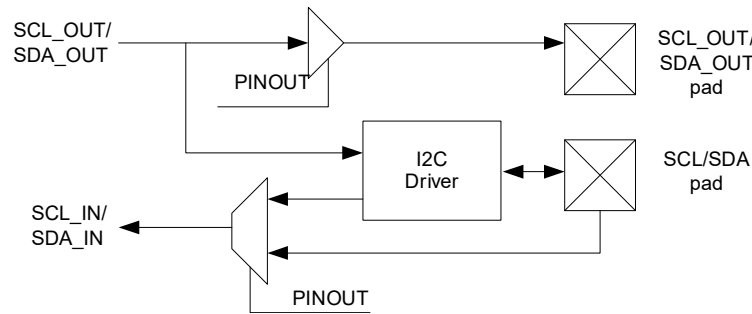
#### 36.6.3.2 Smart Mode

The I<sup>2</sup>C interface has a Smart mode that simplifies application code and minimizes the user interaction needed to adhere to the I<sup>2</sup>C protocol. The Smart mode accomplishes this by automatically issuing an ACK or NACK (based on the content of CTRLB.ACKACT) as soon as DATA.DATA is read.

#### 36.6.3.3 4-Wire Mode

Writing a '1' to the Pin Usage bit in the Control A register (CTRLA.PINOUT) will enable 4-Wire mode operation. In this mode, the internal I<sup>2</sup>C tri-state drivers are bypassed, and an external I<sup>2</sup>C compliant tri-state driver is needed when connecting to an I<sup>2</sup>C bus.

**Figure 36-14. I<sup>2</sup>C Pad Interface**



### 36.6.3.4 Quick Command

Setting the Quick Command Enable bit in the Control B register (CTRLB.QCEN) enables quick command. When quick command is enabled, the corresponding Interrupt flag (INTFLAG.SB or INTFLAG.MB) is set immediately after the slave acknowledges the address. At this point, the software can either issue a Stop command or a repeated start by writing CTRLB.CMD or ADDR.ADDR.

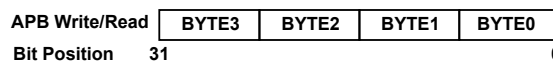
### 36.6.3.5 32-bit Extension

For better system bus utilization, 32-bit data receive and transmit can be enabled by writing to the Data 32-bit bit field in the Control C register (CTRLC.DATA32B=1). When enabled, write and read transaction to/from the DATA register are 32 bit in size.

If frames are not multiples of 4 Bytes, the Length Counter (LENGTH.LEN) and Length Enable (LENGTH.LENEN) must be configured before data transfer begins. LENGTH.LEN must be enabled only when CTRLC.DATA32B is enabled.

The figure below shows the order of transmit and receive when using 32-bit mode. Bytes are transmitted or received and stored in order from 0 to 3.

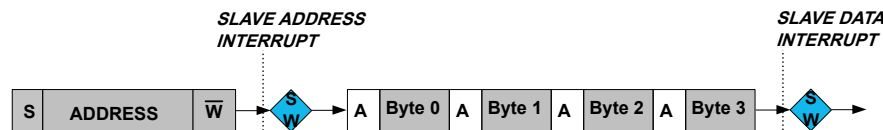
**Figure 36-15. 32-bit Extension Byte Ordering**



### 32-bit Extension Slave Operation

The figure below shows a transaction with 32-bit Extension enabled (CTRLC.DATA32B=1). In slave operation, the Address Match interrupt in the Interrupt Flag Status and Clear register (INTFLAG.AMATCH) is set after the address is received and available in the DATA register. The Data Ready interrupt (INTFLAG.DRDY) will then be raised for every 4 Bytes transferred.

**Figure 36-16. 32-bit Extension Slave Operation**



The LENGTH register can be written before the frame begins, or when the AMATCH interrupt is set. If the frame size is not LENGTH.LEN Bytes, the Length Error status bit (STATUS.LENERR) is raised. If LENGTH.LEN is not a multiple of 4 Bytes, the final INTFLAG.DRDY interrupt is raised when the last Byte is received for master reads. For master writes, the last data byte will be automatically NACKed. On address recognition, the internal length counter is reset in preparation for the incoming frame.

High Speed transactions start with a Full Speed Master Code. When a Master Code is detected, no data is received and the next expected operation is a repeated start. For this reason, the length is not counted



after a Master Code is received. In this case, no Length Error (STATUS.LENERR) is registered, regardless of the LENGTH.LENEN setting.

When SCL clock stretch mode is selected (CTRLA.SCLSM=1) and the transaction is a master write, the selected Acknowledge Action (CTRLB.ACKACT) will only be used to ACK/NACK each 4th byte. All other bytes are ACKed. This allows the user to write CTRLB.ACKACT=1 in the final interrupt, so that the last byte in a 32-bit word will be NACKed.

Writing to the LENGTH register while a frame is in progress will produce unpredictable results. If LENGTH.LENEN is not set and a frame is not a multiple of 4 Bytes, the remainder will be lost.

### 32-bit Extension Master Operation

When using the I<sup>2</sup>C configured as Master, the Address register must be written with the desired address (ADDR.ADDR), and optionally, the transaction Length and transaction Length Enable bits (ADDR.LEN and ADDR.LENEN) can be written. When ADDR.LENEN is written to '1' along with ADDR.ADDR, ADDR.LEN determines the number of data bytes in the transaction from 0 to 255. Then, the ADDR.LEN bytes are transferred, followed by an automatically generated NACK (for master reads) and a STOP.

The INTFLAG.SB or INTFLAG.MB are raised for every 4 Bytes transferred. If the transaction is a master read and ADDR.LEN is not a multiple of 4 Bytes, the final INTFLAG.SB is set when the last byte is received.

When SCL clock stretch mode is enabled (CTRLA.SCLSM=1) and the transaction is a master read, the selected Acknowledge Action (CTRLB.ACKACT) will only be used to ACK/NACK each 4th Byte. All other bytes are ACKed. This allows the user to set CTRLB.ACKACT=1 in the final interrupt, so that the last byte in a 32-bit word will be NACKed.

If a NACK is received by the slave for a master write transaction before ADDR.LEN bytes, a STOP will be automatically generated, and the length error (STATUS.LENERR) is raised along with the INTFLAG.ERROR interrupt.

### 36.6.4 DMA, Interrupts and Events

Each interrupt source has its own Interrupt flag. The Interrupt flag in the Interrupt Flag Status and Clear register (INTFLAG) will be set when the Interrupt condition is met. Each interrupt can be individually enabled by writing '1' to the corresponding bit in the Interrupt Enable Set register (INTENSET), and disabled by writing '1' to the corresponding bit in the Interrupt Enable Clear register (INTENCLR). An interrupt request is generated when the Interrupt flag is set and the corresponding interrupt is enabled. The interrupt request is active until the Interrupt flag is cleared, the interrupt is disabled or the I<sup>2</sup>C is reset. See the [36.8.6 INTFLAG \(Slave\)](#) or [36.10.7 INTFLAG \(Master\)](#) register for details on how to clear Interrupt flags.



# SAM D5x/E5x Family Data Sheet

## SERCOM I2C – Inter-Integrated Circuit

**Table 36-1. Module Request for SERCOM I<sup>2</sup>C Slave**

Condition	Request		
	DMA	Interrupt	Event
Data needed for transmit (TX) (Slave Transmit mode)	Yes (request cleared when data is written)		NA
Data received (RX) (Slave Receive mode)	Yes (request cleared when data is read)		
Data Ready (DRDY)		Yes	
Address Match (AMATCH)		Yes	
Stop received (PREC)		Yes	
Error (ERROR)		Yes	

**Table 36-2. Module Request for SERCOM I<sup>2</sup>C Master**

Condition	Request		
	DMA	Interrupt	Event
Data needed for transmit (TX) (Master Transmit mode)	Yes (request cleared when data is written)		NA
Data needed for transmit (RX) (Master Transmit mode)	Yes (request cleared when data is read)		
Master on Bus (MB)		Yes	
Stop received (SB)		Yes	
Error (ERROR)		Yes	

### 36.6.4.1 DMA Operation

Smart mode must be enabled for DMA operation in the Control B register by writing CTRLB.SMEN=1.

#### 36.6.4.1.1 Slave DMA

When using the I<sup>2</sup>C slave with DMA, an address match will cause the address Interrupt flag (INTFLAG.ADDRMATCH) to be raised. After the interrupt has been serviced, data transfer will be performed through DMA.

The I<sup>2</sup>C slave generates the following requests:

- Write data received (RX): The request is set when master write data is received. The request is cleared when DATA is read.

- Read data needed for transmit (TX): The request is set when data is needed for a master read operation. The request is cleared when DATA is written.

### 36.6.4.1.2 Master DMA

When using the I<sup>2</sup>C master with DMA, the ADDR register must be written with the desired address (ADDR.ADDR), transaction length (ADDR.LEN), and transaction length enable (ADDR.LENEN). When ADDR.LENEN is written to 1 along with ADDR.ADDR, ADDR.LEN determines the number of data bytes in the transaction from 0 to 255. DMA is then used to transfer ADDR.LEN bytes followed by an automatically generated NACK (for master reads) and a STOP.

If a NACK is received by the slave for a master write transaction before ADDR.LEN bytes, a STOP will be automatically generated and the length error (STATUS.LENERR) will be raised along with the INTFLAG.ERROR interrupt.

The I<sup>2</sup>C master generates the following requests:

- Read data received (RX): The request is set when master read data is received. The request is cleared when DATA is read.
- Write data needed for transmit (TX): The request is set when data is needed for a master write operation. The request is cleared when DATA is written.

### 36.6.4.2 Interrupts

The I<sup>2</sup>C slave has the following interrupt sources. These are asynchronous interrupts. They can wake-up the device from any Sleep mode:

- Error (ERROR)
- Data Ready (DRDY)
- Address Match (AMATCH)
- Stop Received (PREC)

The I<sup>2</sup>C master has the following interrupt sources. These are asynchronous interrupts. They can wake-up the device from any Sleep mode:

- Error (ERROR)
- Slave on Bus (SB)
- Master on Bus (MB)

Each interrupt source has its own Interrupt flag. The Interrupt flag in the Interrupt Flag Status and Clear register (INTFLAG) will be set when the Interrupt condition is met. Each interrupt can be individually enabled by writing '1' to the corresponding bit in the Interrupt Enable Set register (INTENSET), and disabled by writing '1' to the corresponding bit in the Interrupt Enable Clear register (INTENCLR). An interrupt request is generated when the Interrupt flag is set and the corresponding interrupt is enabled. The interrupt request is active until the Interrupt flag is cleared, the interrupt is disabled or the I<sup>2</sup>C is reset. See the INTFLAG register for details on how to clear Interrupt flags.

The value of INTFLAG indicates which interrupt is executed. Note that interrupts must be globally enabled for interrupt requests. Refer to *Nested Vector Interrupt Controller* for details.

### Related Links

[10.2 Nested Vector Interrupt Controller](#)

### 36.6.4.3 Events

Not applicable.

### 36.6.5 Sleep Mode Operation

#### I<sup>2</sup>C Master Operation

The generic clock (GCLK\_SERCOMx\_CORE) will continue to run in idle sleep mode. If the Run In Standby bit in the Control A register (CTRLA.RUNSTDBY) is '1', the GLK\_SERCOMx\_CORE will also run in Standby Sleep mode. Any interrupt can wake-up the device.

If CTRLA.RUNSTDBY=0, the GLK\_SERCOMx\_CORE will be disabled after any ongoing transaction is finished. Any interrupt can wake-up the device.

#### I<sup>2</sup>C Slave Operation

Writing CTRLA.RUNSTDBY=1 will allow the Address Match interrupt to wake-up the device.

When CTRLA.RUNSTDBY=0, all receptions will be dropped.

### 36.6.6 Synchronization

Due to asynchronicity between the main clock domain and the peripheral clock domains, some registers need to be synchronized when written or read.

The following bits are synchronized when written:

- Software Reset bit in the CTRLA register (CTRLA.SWRST)
- Enable bit in the CTRLA register (CTRLA.ENABLE)
- Command bits in CTRLB register (CTRLB.CMD)
- Write to Bus State bits in the Status register (STATUS.BUSSTATE)
- Address bits in the Address register (ADDR.ADDR) when in master operation.

The following registers are synchronized when written:

- Data (DATA) when in master operation
- Length (LENGTH) when in slave operation

Required write synchronization is denoted by the "Write-Synchronized" property in the register description.

# SAM D5x/E5x Family Data Sheet

## SERCOM I2C – Inter-Integrated Circuit

### 36.7 Register Summary - I2C Slave

Offset	Name	Bit Pos.								
0x00	CTRLA	7:0	RUNSTDBY			MODE[2:0]		ENABLE	SWRST	
		15:8								
		23:16	SEXTTOEN		SDAHOLD[1:0]				PINOUT	
		31:24		LOWTOUT			SCLSM	SPEED[1:0]		
0x04	CTRLB	7:0								
		15:8	AMODE[1:0]				AACKEN	GCMD	SMEN	
		23:16					ACKACT	CMD[1:0]		
		31:24								
0x08	CTRLC	7:0				SDASETUP[3:0]				
		15:8								
		23:16								
		31:24							DATA32B	
0x0C ... 0x13	Reserved									
0x14	INTENCLR	7:0	ERROR				DRDY	AMATCH	PREC	
0x15	Reserved									
0x16	INTENSET	7:0	ERROR				DRDY	AMATCH	PREC	
0x17	Reserved									
0x18	INTFLAG	7:0	ERROR				DRDY	AMATCH	PREC	
0x19	Reserved									
0x1A	STATUS	7:0	CLKHOLD	LOWTOUT		SR	DIR	RXNACK	COLL	BUSERR
		15:8						HS	SEXTTOUT	
0x1C	SYNCBUSY	7:0				LENGTH			ENABLE	SWRST
		15:8								
		23:16								
		31:24								
0x20 ... 0x21	Reserved									
0x22	LENGTH	7:0	LEN[7:0]							
		15:8								LENEN
0x24	ADDR	7:0	ADDR[6:0]							GENCEN
		15:8	TENBITEN					ADDR[9:7]		
		23:16	ADDRMASK[6:0]							
		31:24						ADDRMASK[9:7]		
0x28	DATA	7:0	DATA[7:0]							
		15:8	DATA[15:8]							
		23:16	DATA[23:16]							
		31:24	DATA[31:24]							

### 36.8 Register Description - I<sup>2</sup>C Slave

Registers can be 8, 16, or 32 bits wide. Atomic 8-, 16- and 32-bit accesses are supported. In addition, the 8-bit quarters and 16-bit halves of a 32-bit register, and the 8-bit halves of a 16-bit register can be accessed directly.

Some registers are optionally write-protected by the Peripheral Access Controller (PAC). Optional PAC write protection is denoted by the "PAC Write-Protection" property in each individual register description. For details, refer to [36.5.8 Register Access Protection](#).

Some registers are synchronized when read and/or written. Synchronization is denoted by the "Write-Synchronized" or the "Read-Synchronized" property in each individual register description. For details, refer to [36.6.6 Synchronization](#).

Some registers are enable-protected, meaning they can only be written when the peripheral is disabled. Enable-protection is denoted by the "Enable-Protected" property in each individual register description.

# SAM D5x/E5x Family Data Sheet

## SERCOM I2C – Inter-Integrated Circuit

### 36.8.1 Control A

**Name:** CTRLA  
**Offset:** 0x00  
**Reset:** 0x00000000  
**Property:** PAC Write-Protection, Enable-Protected, Write-Synchronized

Bit	31	30	29	28	27	26	25	24
		LOWTOUT			SCLSM		SPEED[1:0]	
Access		R/W			R/W		R/W	R/W
Reset		0			0		0	0
Bit	23	22	21	20	19	18	17	16
	SEXTTOEN		SDAHOLD[1:0]					PINOUT
Access	R/W		R/W	R/W				R/W
Reset	0		0	0				0
Bit	15	14	13	12	11	10	9	8
Access								
Reset								
Bit	7	6	5	4	3	2	1	0
	RUNSTDBY			MODE[2:0]			ENABLE	SWRST
Access	R/W			R/W	R/W	R/W	R/W	R/W
Reset	0			0	0	0	0	0

#### Bit 30 – LOWTOUT SCL Low Time-Out

This bit enables the SCL low time-out. If SCL is held low for 25ms-35ms, the slave will release its clock hold, if enabled, and reset the internal state machine. Any interrupt flags set at the time of time-out will remain set.

Value	Description
0	Time-out disabled.
1	Time-out enabled.

#### Bit 27 – SCLSM SCL Clock Stretch Mode

This bit controls when SCL will be stretched for software interaction. This bit is not synchronized.

Value	Description
0	SCL stretch according to <a href="#">Figure 36-10</a>
1	SCL stretch only after ACK bit according to <a href="#">Figure 36-11</a>

#### Bits 25:24 – SPEED[1:0] Transfer Speed

These bits define bus speed. These bits are not synchronized.

Value	Description
0x0	Standard-mode (Sm) up to 100 kHz and Fast-mode (Fm) up to 400 kHz
0x1	Fast-mode Plus (Fm+) up to 1 MHz

# SAM D5x/E5x Family Data Sheet

## SERCOM I2C – Inter-Integrated Circuit

Value	Description
0x2	High-speed mode (Hs-mode) up to 3.4 MHz
0x3	Reserved

### Bit 23 – SEXTTOEN Slave SCL Low Extend Time-Out

This bit enables the slave SCL low extend time-out. If SCL is cumulatively held low for greater than 25ms from the initial START to a STOP, the slave will release its clock hold if enabled and reset the internal state machine. Any interrupt flags set at the time of time-out will remain set. If the address was recognized, PREC will be set when a STOP is received.

This bit is not synchronized.

Value	Description
0	Time-out disabled
1	Time-out enabled

### Bits 21:20 – SDAHOLD[1:0] SDA Hold Time

These bits define the SDA hold time with respect to the negative edge of SCL.

These bits are not synchronized.

Value	Name	Description
0x0	DIS	Disabled
0x1	75	50-100ns hold time
0x2	450	300-600ns hold time
0x3	600	400-800ns hold time

### Bit 16 – PINOUT Pin Usage

This bit sets the pin usage to either two- or four-wire operation:

This bit is not synchronized.

Value	Description
0	4-wire operation disabled
1	4-wire operation enabled

### Bit 7 – RUNSTDBY Run in Standby

This bit defines the functionality in standby sleep mode.

This bit is not synchronized.

Value	Description
0	Disabled – All reception is dropped.
1	Wake on address match, if enabled.

### Bits 4:2 – MODE[2:0] Operating Mode

These bits must be written to 0x04 to select the I<sup>2</sup>C slave serial communication interface of the SERCOM.

These bits are not synchronized.

### Bit 1 – ENABLE Enable

Due to synchronization, there is delay from writing CTRLA.ENABLE until the peripheral is enabled/disabled. The value written to CTRL.ENABLE will read back immediately and the Enable Synchronization Busy bit in the Synchronization Busy register (SYNCBUSY.ENABLE) will be set. SYNCBUSY.ENABLE will be cleared when the operation is complete.

This bit is not enable-protected.

Value	Description
0	The peripheral is disabled or being disabled.

# SAM D5x/E5x Family Data Sheet

## SERCOM I2C – Inter-Integrated Circuit

Value	Description
1	The peripheral is enabled.

### Bit 0 – SWRST Software Reset

Writing '0' to this bit has no effect.

Writing '1' to this bit resets all registers in the SERCOM, except DBGCTRL, to their initial state, and the SERCOM will be disabled.

Writing '1' to CTRLA.SWRST will always take precedence, meaning that all other writes in the same write-operation will be discarded. Any register write access during the ongoing reset will result in an APB error. Reading any register will return the reset value of the register.

Due to synchronization, there is a delay from writing CTRLA.SWRST until the reset is complete.

CTRLA.SWRST and SYNCBUSY.SWRST will both be cleared when the reset is complete.

This bit is not enable-protected.

Value	Description
0	There is no reset operation ongoing.
1	The reset operation is ongoing.



# SAM D5x/E5x Family Data Sheet

## SERCOM I2C – Inter-Integrated Circuit

### 36.8.2 Control B

**Name:** CTRLB  
**Offset:** 0x04  
**Reset:** 0x00000000  
**Property:** PAC Write-Protection, Enable-Protected, Write-Synchronized

Bit	31	30	29	28	27	26	25	24	
Access									
Reset									
Bit	23	22	21	20	19	18	17	16	
						ACKACT	CMD[1:0]		
Access						R/W	W	W	
Reset						0	0	0	
Bit	15	14	13	12	11	10	9	8	
	AMODE[1:0]					AACKEN	GCMD	SMEN	
Access	R/W	R/W				R/W	R/W	R/W	
Reset	0	0				0	0	0	
Bit	7	6	5	4	3	2	1	0	
Access									
Reset									

#### Bit 18 – ACKACT Acknowledge Action

This bit defines the slave's acknowledge behavior after an address or data byte is received from the master. The acknowledge action is executed when a command is written to the CMD bits. If smart mode is enabled (CTRLB.SMEN=1), the acknowledge action is performed when the DATA register is read. ACKACT shall not be updated more than once between each peripheral interrupts request. This bit is not enable-protected.

Value	Description
0	Send ACK
1	Send NACK

#### Bits 17:16 – CMD[1:0] Command

This bit field triggers the slave operation as the below. The CMD bits are strobe bits, and always read as zero. The operation is dependent on the slave interrupt flags, INTFLAG.DRDY and INTFLAG.AMATCH, in addition to STATUS.DIR.

All interrupt flags (INTFLAG.DRDY, INTFLAG.AMATCH and INTFLAG.PREC) are automatically cleared when a command is given.

This bit is not enable-protected.

**Table 36-3. Command Description**

CMD[1:0]	DIR	Action
0x0	X	(No action)

# SAM D5x/E5x Family Data Sheet

## SERCOM I2C – Inter-Integrated Circuit

.....continued

CMD[1:0]	DIR	Action
0x1	X	(Reserved)
0x2		Used to complete a transaction in response to a data interrupt (DRDY)
	0 (Master write)	Execute acknowledge action succeeded by waiting for any start (S/Sr) condition
	1 (Master read)	Wait for any start (S/Sr) condition
0x3		Used in response to an address interrupt (AMATCH)
	0 (Master write)	Execute acknowledge action succeeded by reception of next byte
	1 (Master read)	Execute acknowledge action succeeded by slave data interrupt
		Used in response to a data interrupt (DRDY)
	0 (Master write)	Execute acknowledge action succeeded by reception of next byte
	1 (Master read)	Execute a byte read operation followed by ACK/NACK reception

### Bits 15:14 – AMODE[1:0] Address Mode

These bits set the addressing mode.

These bits are not write-synchronized.

Value	Name	Description
0x0	MASK	The slave responds to the address written in ADDR.ADDR masked by the value in ADDR.ADDRMASK. See <i>SERCOM – Serial Communication Interface</i> for additional information.
0x1	2_ADDR	The slave responds to the two unique addresses in ADDR.ADDR and ADDR.ADDRMASK.
0x2	RANGE	The slave responds to the range of addresses between and including ADDR.ADDR and ADDR.ADDRMASK. ADDR.ADDR is the upper limit.
0x3	-	Reserved.

### Bit 10 – AACKEN Automatic Acknowledge Enable

This bit enables the address to be automatically acknowledged if there is an address match.

This bit is not write-synchronized.

Value	Description
0	Automatic acknowledge is disabled.
1	Automatic acknowledge is enabled.

### Bit 9 – GCMD PMBus Group Command

This bit enables PMBus group command support. When enabled, the Stop Recived interrupt flag (INTFLAG.PREC) will be set when a STOP condition is detected if the slave has been addressed since the last STOP condition on the bus.

This bit is not write-synchronized.

Value	Description
0	Group command is disabled.
1	Group command is enabled.

# SAM D5x/E5x Family Data Sheet

## SERCOM I2C – Inter-Integrated Circuit

---

---

### Bit 8 – SMEN Smart Mode Enable

When smart mode is enabled, data is acknowledged automatically when DATA.DATA is read.

This bit is not write-synchronized.

Value	Description
0	Smart mode is disabled.
1	Smart mode is enabled.

### Related Links

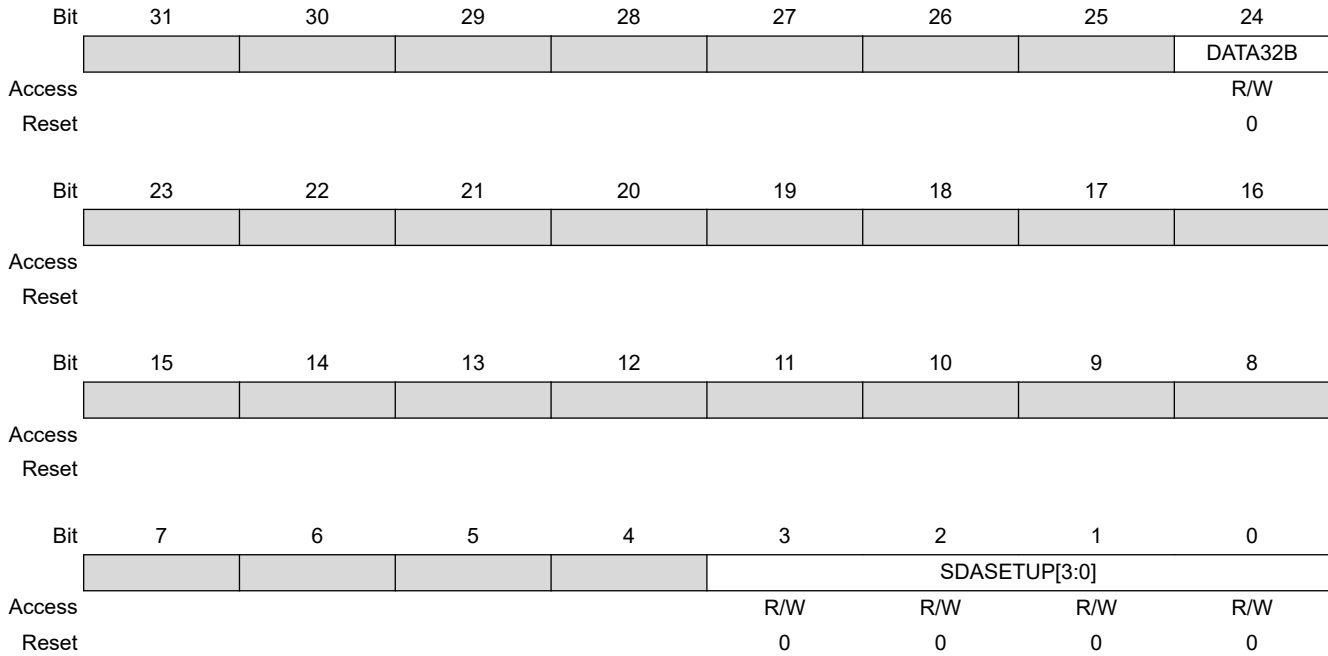
[33. SERCOM – Serial Communication Interface](#)

# SAM D5x/E5x Family Data Sheet

## SERCOM I2C – Inter-Integrated Circuit

### 36.8.3 Control C

**Name:** CTRLC  
**Offset:** 0x08  
**Reset:** 0x00000000  
**Property:** PAC Write-Protection, Enable-Protected



#### Bit 24 – DATA32B Data 32 Bit

This bit enables 32-bit data writes and reads to/from the DATA register.

Value	Description
0	Data transaction to/from DATA are 8-bit in size
1	Data transaction to/from DATA are 32-bit in size

#### Bits 3:0 – SDASETUP[3:0] SDA Setup Time

These bits select the minimum SDA-to-SCL setup time, measured from the release of SDA to the release of SCL:

$$t_{SU:DAT} = (\text{CLK\_SERCOMx} \times \text{APB period}) \times (6 + 16 \times \text{SDASETUP})$$

### 36.8.4 Interrupt Enable Clear

**Name:** INTENCLR  
**Offset:** 0x14  
**Reset:** 0x00  
**Property:** PAC Write-Protection

This register allows the user to disable an interrupt without doing a read-modify-write operation. Changes in this register will also be reflected in the Interrupt Enable Set register (INTENSET).

Bit	7	6	5	4	3	2	1	0
	ERROR					DRDY	AMATCH	PREC
Access	R/W					R/W	R/W	R/W
Reset	0					0	0	0

#### Bit 7 – ERROR Error Interrupt Enable

Writing '0' to this bit has no effect.

Writing '1' to this bit will clear the Error Interrupt Enable bit, which disables the Error interrupt.

Value	Description
0	Error interrupt is disabled.
1	Error interrupt is enabled.

#### Bit 2 – DRDY Data Ready Interrupt Enable

Writing '0' to this bit has no effect.

Writing '1' to this bit will clear the Data Ready bit, which disables the Data Ready interrupt.

Value	Description
0	The Data Ready interrupt is disabled.
1	The Data Ready interrupt is enabled.

#### Bit 1 – AMATCH Address Match Interrupt Enable

Writing '0' to this bit has no effect.

Writing '1' to this bit will clear the Address Match Interrupt Enable bit, which disables the Address Match interrupt.

Value	Description
0	The Address Match interrupt is disabled.
1	The Address Match interrupt is enabled.

#### Bit 0 – PREC Stop Received Interrupt Enable

Writing '0' to this bit has no effect.

Writing '1' to this bit will clear the Stop Received Interrupt Enable bit, which disables the Stop Received interrupt.

Value	Description
0	The Stop Received interrupt is disabled.
1	The Stop Received interrupt is enabled.

### 36.8.5 Interrupt Enable Set

**Name:** INTENSET  
**Offset:** 0x16  
**Reset:** 0x00  
**Property:** PAC Write-Protection

This register allows the user to enable an interrupt without doing a read-modify-write operation. Changes in this register will also be reflected in the Interrupt Enable Clear register (INTENCLR).

Bit	7	6	5	4	3	2	1	0
	ERROR					DRDY	AMATCH	PREC
Access	R/W					R/W	R/W	R/W
Reset	0					0	0	0

#### Bit 7 – ERROR Error Interrupt Enable

Writing '0' to this bit has no effect.

Writing '1' to this bit will set the Error Interrupt Enable bit, which enables the Error interrupt.

Value	Description
0	Error interrupt is disabled.
1	Error interrupt is enabled.

#### Bit 2 – DRDY Data Ready Interrupt Enable

Writing '0' to this bit has no effect.

Writing '1' to this bit will set the Data Ready bit, which enables the Data Ready interrupt.

Value	Description
0	The Data Ready interrupt is disabled.
1	The Data Ready interrupt is enabled.

#### Bit 1 – AMATCH Address Match Interrupt Enable

Writing '0' to this bit has no effect.

Writing '1' to this bit will set the Address Match Interrupt Enable bit, which enables the Address Match interrupt.

Value	Description
0	The Address Match interrupt is disabled.
1	The Address Match interrupt is enabled.

#### Bit 0 – PREC Stop Received Interrupt Enable

Writing '0' to this bit has no effect.

Writing '1' to this bit will set the Stop Received Interrupt Enable bit, which enables the Stop Received interrupt.

Value	Description
0	The Stop Received interrupt is disabled.
1	The Stop Received interrupt is enabled.

### 36.8.6 Interrupt Flag Status and Clear

**Name:** INTFLAG  
**Offset:** 0x18  
**Reset:** 0x00  
**Property:** -

	7	6	5	4	3	2	1	0
	ERROR					DRDY	AMATCH	PREC
Access	R/W					R/W	R/W	R/W
Reset	0					0	0	0

#### Bit 7 – ERROR Error

This bit is set when any error is detected. Errors that will set this flag have corresponding status flags in the STATUS register. The corresponding bits in STATUS are LENERR, SEXTTOUT, LOWTOUT, COLL, and BUSERR.

Writing '0' to this bit has no effect.

Writing '1' to this bit will clear the flag.

#### Bit 2 – DRDY Data Ready

This flag is set when a I<sup>2</sup>C slave byte transmission is successfully completed.

The flag is cleared by hardware when either:

- Writing to the DATA register.
- Reading the DATA register with Smart mode enabled.
- Writing a valid command to the CMD register.

Writing '0' to this bit has no effect.

Writing '1' to this bit will clear the Data Ready Interrupt flag.

#### Bit 1 – AMATCH Address Match

This flag is set when the I<sup>2</sup>C slave address match logic detects that a valid address has been received.

The flag is cleared by hardware when CTRL.CMD is written.

Writing '0' to this bit has no effect.

Writing '1' to this bit will clear the Address Match Interrupt flag. When cleared, an ACK/NACK will be sent according to CTRLB.ACKACT.

#### Bit 0 – PREC Stop Received

This flag is set when a Stop condition is detected for a transaction being processed. A Stop condition detected between a bus master and another slave will not set this flag, unless the PMBus Group Command is enabled in the Control B register (CTRLB.GCMD=1).

This flag is cleared by hardware after a command is issued on the next address match.

Writing '0' to this bit has no effect.

Writing '1' to this bit will clear the Stop Received Interrupt flag.

# SAM D5x/E5x Family Data Sheet

## SERCOM I2C – Inter-Integrated Circuit

### 36.8.7 Status

**Name:** STATUS  
**Offset:** 0x1A  
**Reset:** 0x0000  
**Property:** -

	Bit	15	14	13	12	11	10	9	8
							HS	SEXTTOUT	
Access							R/W	R/W	
Reset							0	0	
	Bit	7	6	5	4	3	2	1	0
		CLKHOLD	LOWTOUT		SR	DIR	RXNACK	COLL	BUSERR
Access		R	R/W		R	R	R	R/W	R/W
Reset		0	0		0	0	0	0	0

#### Bit 10 – HS High-speed

This bit is set if the slave detects a START followed by a Master Code transmission. Writing a '0' to this bit has no effect. Writing a '1' to this bit will clear the status. However, this flag is automatically cleared when a STOP is received.

#### Bit 9 – SEXTTOUT Slave SCL Low Extend Time-Out

This bit is set if a slave SCL low extend time-out occurs. This bit is cleared automatically if responding to a new start condition with ACK or NACK (write 3 to CTRLB.CMD) or when INTFLAG.AMATCH is cleared. Writing a '0' to this bit has no effect. Writing a '1' to this bit will clear the status.

Value	Description
0	No SCL low extend time-out has occurred.
1	SCL low extend time-out has occurred.

#### Bit 7 – CLKHOLD Clock Hold

The slave Clock Hold bit (STATUS.CLKHOLD) is set when the slave is holding the SCL line low, stretching the I2C clock. Software should consider this bit a read-only status flag that is set when INTFLAG.DRDY or INTFLAG.AMATCH is set. This bit is automatically cleared when the corresponding interrupt is also cleared.

#### Bit 6 – LOWTOUT SCL Low Time-out

This bit is set if an SCL low time-out occurs. This bit is cleared automatically if responding to a new start condition with ACK or NACK (write 3 to CTRLB.CMD) or when INTFLAG.AMATCH is cleared. Writing a '0' to this bit has no effect. Writing a '1' to this bit will clear the status.

Value	Description
0	No SCL low time-out has occurred.
1	SCL low time-out has occurred.



# SAM D5x/E5x Family Data Sheet

## SERCOM I2C – Inter-Integrated Circuit

### Bit 4 – SR Repeated Start

When INTFLAG.AMATCH is raised due to an address match, SR indicates a repeated start or start condition.

This flag is only valid while the INTFLAG.AMATCH flag is one.

Value	Description
0	Start condition on last address match
1	Repeated start condition on last address match

### Bit 3 – DIR Read / Write Direction

The Read/Write Direction (STATUS.DIR) bit stores the direction of the last address packet received from a master.

Value	Description
0	Master write operation is in progress.
1	Master read operation is in progress.

### Bit 2 – RXNACK Received Not Acknowledge

This bit indicates whether the last data packet sent was acknowledged or not.

Value	Description
0	Master responded with ACK.
1	Master responded with NACK.

### Bit 1 – COLL Transmit Collision

If set, the I2C slave was not able to transmit a high data or NACK bit, the I2C slave will immediately release the SDA and SCL lines and wait for the next packet addressed to it.

This flag is intended for the SMBus address resolution protocol (ARP). A detected collision in non-ARP situations indicates that there has been a protocol violation, and should be treated as a bus error.

Note that this status will not trigger any interrupt, and should be checked by software to verify that the data were sent correctly. This bit is cleared automatically if responding to an address match with an ACK or a NACK (writing 0x3 to CTRLB.COMD), or INTFLAG.AMATCH is cleared.

Writing a '0' to this bit has no effect.

Writing a '1' to this bit will clear the status.

Value	Description
0	No collision detected on last data byte sent.
1	Collision detected on last data byte sent.

### Bit 0 – BUSERR Bus Error

The Bus Error bit (STATUS.BUSERR) indicates that an illegal bus condition has occurred on the bus, regardless of bus ownership. An illegal bus condition is detected if a protocol violating start, repeated start or stop is detected on the I2C bus lines. A start condition directly followed by a stop condition is one example of a protocol violation. If a time-out occurs during a frame, this is also considered a protocol violation, and will set STATUS.BUSERR.

This bit is cleared automatically if responding to an address match with an ACK or a NACK (writing 0x3 to CTRLB.COMD) or INTFLAG.AMATCH is cleared.

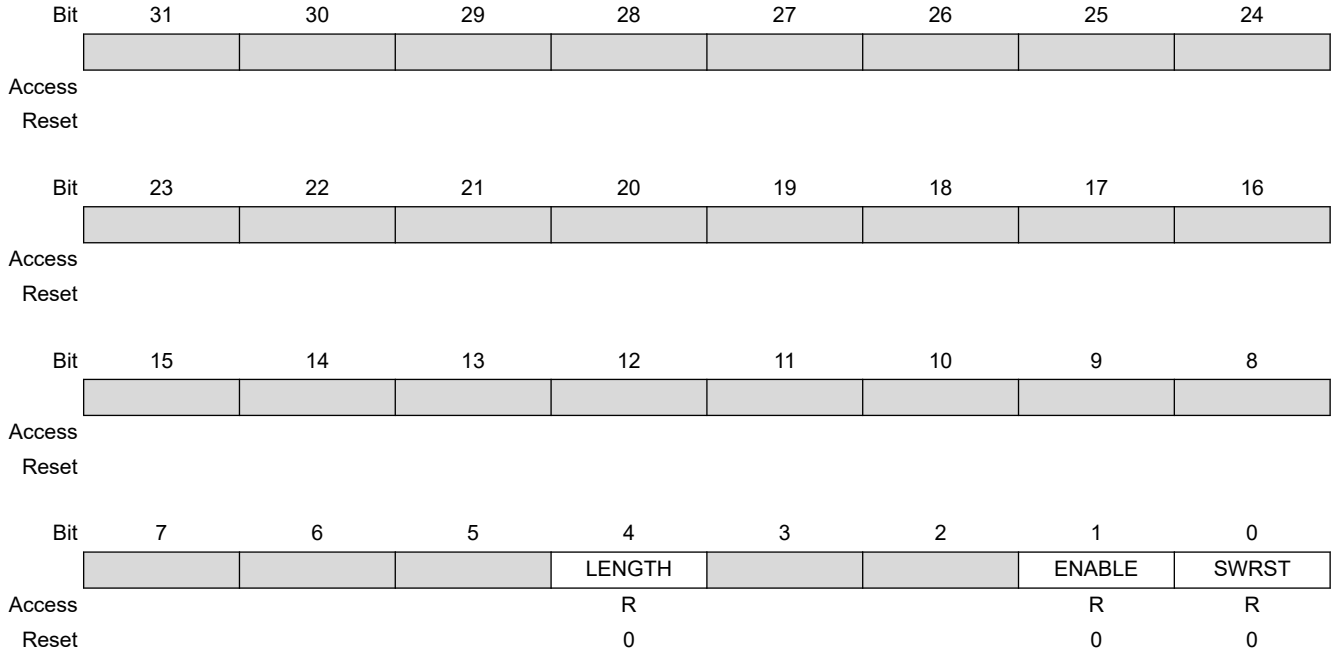
Writing a '1' to this bit will clear the status.

Writing a '0' to this bit has no effect.

Value	Description
0	No bus error detected.
1	Bus error detected.

### 36.8.8 Synchronization Busy

**Name:** SYNCBUSY  
**Offset:** 0x1C  
**Reset:** 0x00000000  
**Property:** -



#### Bit 4 – LENGTH LENGTH Synchronization Busy

Writing LENGTH requires synchronization. When written, this bit will be set until synchronization is complete. If LENGTH is written while SYNCBUSY.LENGTH is asserted, an APB error will be generated.

**Note:** In slave mode, the clock is only running during data transfer, so SYNCBUSY.LENGTH will remain asserted until the next data transfer begins.

Value	Description
0	LENGTH synchronization is not busy.
1	LENGTH synchronization is busy.

#### Bit 1 – ENABLE SERCOM Enable Synchronization Busy

Enabling and disabling the SERCOM (CTRLA.ENABLE) requires synchronization. When written, the SYNCBUSY.ENABLE bit will be set until synchronization is complete.

Value	Description
0	Enable synchronization is not busy.
1	Enable synchronization is busy.

#### Bit 0 – SWRST Software Reset Synchronization Busy

Resetting the SERCOM (CTRLA.SWRST) requires synchronization. When written, the SYNCBUSY.SWRST bit will be set until synchronization is complete.

Value	Description
0	SWRST synchronization is not busy.

# SAM D5x/E5x Family Data Sheet

## SERCOM I2C – Inter-Integrated Circuit

---

---

Value	Description
1	SWRST synchronization is busy.

# SAM D5x/E5x Family Data Sheet

## SERCOM I2C – Inter-Integrated Circuit

### 36.8.9 Length

**Name:** LENGTH  
**Offset:** 0x22  
**Reset:** 0x0000  
**Property:** PAC Write-Protection, Write-Synchronized

	15		14		13		12		11		10		9		8
	LENEN														
Access	R/W														
Reset	0														
	7		6		5		4		3		2		1		0
	LEN[7:0]														
Access	R/W		R/W		R/W		R/W		R/W		R/W		R/W		R/W
Reset	0		0		0		0		0		0		0		0

#### Bit 8 – LENEN Data Length Enable

In 32-bit Extension mode (CTRLC.DATA32B=1), this bit field enables the length counter.

Value	Description
0	Length counter is disabled.
1	Length counter is enabled.

#### Bits 7:0 – LEN[7:0] Data Length

In 32-bit Extension mode (CTRLC.DATA32B=1) with Data Length counting enabled (LENGTH.LENEN), this bit field configures the data length from 0 to 255 Bytes after which the flag INTFLAG.DRDY is raised.

# SAM D5x/E5x Family Data Sheet

## SERCOM I2C – Inter-Integrated Circuit

### 36.8.10 Address

**Name:** ADDR  
**Offset:** 0x24  
**Reset:** 0x00000000  
**Property:** PAC Write-Protection, Enable-Protected

	Bit	31	30	29	28	27	26	25	24	
		ADDRMASK[9:7]								
Access							R/W	R/W	R/W	
Reset							0	0	0	
	Bit	23	22	21	20	19	18	17	16	
		ADDRMASK[6:0]								
Access		R/W	R/W	R/W	R/W	R/W	R/W	R/W		
Reset		0	0	0	0	0	0	0		
	Bit	15	14	13	12	11	10	9	8	
		TENBITEN					ADDR[9:7]			
Access		R/W					R/W	R/W	R/W	
Reset		0					0	0	0	
	Bit	7	6	5	4	3	2	1	0	
		ADDR[6:0]							GENCEN	
Access		R/W	R/W	R/W	R/W	R/W	R/W	R/W	R/W	
Reset		0	0	0	0	0	0	0	0	

#### Bits 26:17 – ADDRMASK[9:0] Address Mask

These bits act as a second address match register, an address mask register or the lower limit of an address range, depending on the CTRLB.AMODE setting.

#### Bit 15 – TENBITEN Ten Bit Addressing Enable

Value	Description
0	10-bit address recognition disabled.
1	10-bit address recognition enabled.

#### Bits 10:1 – ADDR[9:0] Address

These bits contain the I<sup>2</sup>C slave address used by the slave address match logic to determine if a master has addressed the slave.

When using 7-bit addressing, the slave address is represented by ADDR[6:0].

When using 10-bit addressing (ADDR.TENBITEN=1), the slave address is represented by ADDR[9:0].

When the address match logic detects a match, INTFLAG.AMATCH is set and STATUS.DIR is updated to indicate whether it is a read or a write transaction.

#### Bit 0 – GENCEN General Call Address Enable

A general call address is an address consisting of all-zeroes, including the direction bit (master write).

Value	Description
0	General call address recognition disabled.
1	General call address recognition enabled.

# SAM D5x/E5x Family Data Sheet

## SERCOM I2C – Inter-Integrated Circuit

### 36.8.11 Data

**Name:** DATA  
**Offset:** 0x28  
**Reset:** 0x00000000  
**Property:** Read/Write

	Bit	31	30	29	28	27	26	25	24
		DATA[31:24]							
Access		R/W	R/W	R/W	R/W	R/W	R/W	R/W	R/W
Reset		0	0	0	0	0	0	0	0
	Bit	23	22	21	20	19	18	17	16
		DATA[23:16]							
Access		R/W	R/W	R/W	R/W	R/W	R/W	R/W	R/W
Reset		0	0	0	0	0	0	0	0
	Bit	15	14	13	12	11	10	9	8
		DATA[15:8]							
Access		R/W	R/W	R/W	R/W	R/W	R/W	R/W	R/W
Reset		0	0	0	0	0	0	0	0
	Bit	7	6	5	4	3	2	1	0
		DATA[7:0]							
Access		R/W	R/W	R/W	R/W	R/W	R/W	R/W	R/W
Reset		0	0	0	0	0	0	0	0

#### Bits 31:0 – DATA[31:0] Data

The slave data register I/O location (DATA.DATA) provides access to the master transmit and receive data buffers. Reading valid data or writing data to be transmitted can be successfully done only when SCL is held low by the slave (STATUS.CLKHOLD is set). An exception occurs when reading the last data byte after the stop condition has been received.

Accessing DATA.DATA auto-triggers I<sup>2</sup>C bus operations. The operation performed depends on the state of CTRLB.ACKACT, CTRLB.SMEN and the type of access (read/write).

When CTRLC.DATA32B=1, read and write transactions from/to the DATA register are 32 bit in size. Otherwise, reads and writes are 8 bit.

# SAM D5x/E5x Family Data Sheet

## SERCOM I2C – Inter-Integrated Circuit

### 36.9 Register Summary - I2C Master

Offset	Name	Bit Pos.								
0x00	CTRLA	7:0	RUNSTDBY			MODE[2:0]		ENABLE	SWRST	
		15:8								
		23:16	SEXTTOEN	MEXTTOEN	SDAHOLD[1:0]				PINOUT	
		31:24		LOWTOUT	INACTOUT[1:0]		SCLSM		SPEED[1:0]	
0x04	CTRLB	7:0								
		15:8					QCEN	SMEN		
		23:16					ACKACT	CMD[1:0]		
		31:24								
0x08	CTRLC	7:0								
		15:8								
		23:16								
		31:24							DATA32B	
0x0C	BAUD	7:0	BAUD[7:0]							
		15:8	BAUDLOW[7:0]							
		23:16	HSBAUD[7:0]							
		31:24	HSBAUDLOW[7:0]							
0x10 ... 0x13	Reserved									
0x14	INTENCLR	7:0	ERROR					SB	MB	
0x15	Reserved									
0x16	INTENSET	7:0	ERROR					SB	MB	
0x17	Reserved									
0x18	INTFLAG	7:0	ERROR					SB	MB	
0x19	Reserved									
0x1A	STATUS	7:0	CLKHOLD	LOWTOUT	BUSSTATE[1:0]			RXNACK	ARBLOST	BUSERR
		15:8						LENERR	SEXTTOUT	MEXTTOUT
0x1C	SYNCBUSY	7:0						SYSOP	ENABLE	SWRST
		15:8								
		23:16								
		31:24								
0x20 ... 0x23	Reserved									
0x24	ADDR	7:0	ADDR[7:0]							
		15:8	TENBITEN	HS	LENEN			ADDR[10:8]		
		23:16	LEN[7:0]							
		31:24								
0x28	DATA	7:0	DATA[7:0]							
		15:8	DATA[15:8]							
		23:16	DATA[23:16]							
		31:24	DATA[31:24]							

# SAM D5x/E5x Family Data Sheet

## SERCOM I2C – Inter-Integrated Circuit

.....continued

Offset	Name	Bit Pos.								
0x2C	Reserved									
...										
0x2F										
0x30	DBGCTRL	7:0								DBGSTOP

### 36.10 Register Description - I<sup>2</sup>C Master

Registers can be 8, 16, or 32 bits wide. Atomic 8-, 16- and 32-bit accesses are supported. In addition, the 8-bit quarters and 16-bit halves of a 32-bit register, and the 8-bit halves of a 16-bit register can be accessed directly.

Some registers are optionally write-protected by the Peripheral Access Controller (PAC). Optional PAC write protection is denoted by the "PAC Write-Protection" property in each individual register description. For details, refer to [36.5.8 Register Access Protection](#).

Some registers are synchronized when read and/or written. Synchronization is denoted by the "Write-Synchronized" or the "Read-Synchronized" property in each individual register description. For details, refer to [36.6.6 Synchronization](#).

Some registers are enable-protected, meaning they can only be written when the peripheral is disabled. Enable-protection is denoted by the "Enable-Protected" property in each individual register description.



# SAM D5x/E5x Family Data Sheet

## SERCOM I2C – Inter-Integrated Circuit

### 36.10.1 Control A

**Name:** CTRLA  
**Offset:** 0x00  
**Reset:** 0x00000000  
**Property:** PAC Write-Protection, Enable-Protected, Write-Synchronized

	Bit	31	30	29	28	27	26	25	24
			LOWTOUT	INACTOUT[1:0]		SCLSM		SPEED[1:0]	
Access			R/W	R/W	R/W	R/W		R/W	R/W
Reset			0	0	0	0		0	0
	Bit	23	22	21	20	19	18	17	16
		SEXTTOEN	MEXTTOEN	SDAHOLD[1:0]					PINOUT
Access		R/W	R/W	R/W	R/W				R/W
Reset		0	0	0	0				0
	Bit	15	14	13	12	11	10	9	8
Access									
Reset									
	Bit	7	6	5	4	3	2	1	0
		RUNSTDBY			MODE[2:0]			ENABLE	SWRST
Access		R/W			R/W	R/W	R/W	R/W	R/W
Reset		0			0	0	0	0	0

#### Bit 30 – LOWTOUT SCL Low Time-Out

This bit enables the SCL low time-out. If SCL is held low for 25ms-35ms, the master will release its clock hold, if enabled, and complete the current transaction. A stop condition will automatically be transmitted. INTFLAG.SB or INTFLAG.MB will be set as normal, but the clock hold will be released. The STATUS.LOWTOUT and STATUS.BUSERR status bits will be set.

This bit is not synchronized.

Value	Description
0	Time-out disabled.
1	Time-out enabled.

#### Bits 29:28 – INACTOUT[1:0] Inactive Time-Out

If the inactive bus time-out is enabled and the bus is inactive for longer than the time-out setting, the bus state logic will be set to idle. An inactive bus arise when either an I<sup>2</sup>C master or slave is holding the SCL low.

Enabling this option is necessary for SMBus compatibility, but can also be used in a non-SMBus set-up. Calculated time-out periods are based on a 100kHz baud rate.

These bits are not synchronized.

Value	Name	Description
0x0	DIS	Disabled
0x1	55US	5-6 SCL cycle time-out (50-60µs)
0x2	105US	10-11 SCL cycle time-out (100-110µs)

# SAM D5x/E5x Family Data Sheet

## SERCOM I2C – Inter-Integrated Circuit

Value	Name	Description
0x3	205US	20-21 SCL cycle time-out (200-210µs)

### Bit 27 – SCLSM SCL Clock Stretch Mode

This bit controls when SCL will be stretched for software interaction.

This bit is not synchronized.

Value	Description
0	SCL stretch according to <a href="#">Figure 36-5</a> .
1	SCL stretch only after ACK bit, <a href="#">Figure 36-6</a> .

### Bits 25:24 – SPEED[1:0] Transfer Speed

These bits define bus speed.

These bits are not synchronized.

Value	Description
0x0	Standard-mode (Sm) up to 100 kHz and Fast-mode (Fm) up to 400 kHz
0x1	Fast-mode Plus (Fm+) up to 1 MHz
0x2	High-speed mode (Hs-mode) up to 3.4 MHz
0x3	Reserved

### Bit 23 – SEXTTOEN Slave SCL Low Extend Time-Out

This bit enables the slave SCL low extend time-out. If SCL is cumulatively held low for greater than 25ms from the initial START to a STOP, the master will release its clock hold if enabled, and complete the current transaction. A STOP will automatically be transmitted.

SB or MB will be set as normal, but CLKHOLD will be release. The MEXTTOUT and BUSERR status bits will be set.

This bit is not synchronized.

Value	Description
0	Time-out disabled
1	Time-out enabled

### Bit 22 – MEXTTOEN Master SCL Low Extend Time-Out

This bit enables the master SCL low extend time-out. If SCL is cumulatively held low for greater than 10ms from START-to-ACK, ACK-to-ACK, or ACK-to-STOP the master will release its clock hold if enabled, and complete the current transaction. A STOP will automatically be transmitted.

SB or MB will be set as normal, but CLKHOLD will be released. The MEXTTOUT and BUSERR status bits will be set.

This bit is not synchronized.

Value	Description
0	Time-out disabled
1	Time-out enabled

### Bits 21:20 – SDAHOLD[1:0] SDA Hold Time

These bits define the SDA hold time with respect to the negative edge of SCL.

These bits are not synchronized.

Value	Name	Description
0x0	DIS	Disabled
0x1	75NS	50-100ns hold time
0x2	450NS	300-600ns hold time
0x3	600NS	400-800ns hold time

# SAM D5x/E5x Family Data Sheet

## SERCOM I2C – Inter-Integrated Circuit

### Bit 16 – PINOUT Pin Usage

This bit set the pin usage to either two- or four-wire operation:

This bit is not synchronized.

Value	Description
0	4-wire operation disabled.
1	4-wire operation enabled.

### Bit 7 – RUNSTDBY Run in Standby

This bit defines the functionality in standby sleep mode.

This bit is not synchronized.

Value	Description
0	GCLK_SERCOMx_CORE is disabled and the I <sup>2</sup> C master will not operate in standby sleep mode.
1	GCLK_SERCOMx_CORE is enabled in all sleep modes.

### Bits 4:2 – MODE[2:0] Operating Mode

These bits must be written to 0x5 to select the I<sup>2</sup>C master serial communication interface of the SERCOM.

These bits are not synchronized.

### Bit 1 – ENABLE Enable

Due to synchronization, there is delay from writing CTRLA.ENABLE until the peripheral is enabled/disabled. The value written to CTRLA.ENABLE will read back immediately and the Synchronization Enable Busy bit in the Synchronization Busy register (SYNCBUSY.ENABLE) will be set. SYNCBUSY.ENABLE will be cleared when the operation is complete.

This bit is not enable-protected.

Value	Description
0	The peripheral is disabled or being disabled.
1	The peripheral is enabled.

### Bit 0 – SWRST Software Reset

Writing '0' to this bit has no effect.

Writing '1' to this bit resets all registers in the SERCOM, except DBGCTRL, to their initial state, and the SERCOM will be disabled.

Writing '1' to CTRLA.SWRST will always take precedence, meaning that all other writes in the same write-operation will be discarded. Any register write access during the ongoing reset will result in an APB error. Reading any register will return the reset value of the register.

Due to synchronization there is a delay from writing CTRLA.SWRST until the reset is complete.

CTRLA.SWRST and SYNCBUSY.SWRST will both be cleared when the reset is complete.

This bit is not enable-protected.

Value	Description
0	There is no reset operation ongoing.
1	The reset operation is ongoing.

# SAM D5x/E5x Family Data Sheet

## SERCOM I2C – Inter-Integrated Circuit

### 36.10.2 Control B

**Name:** CTRLB  
**Offset:** 0x04  
**Reset:** 0x00000000  
**Property:** PAC Write-Protection, Enable-Protected, Write-Synchronized

	31	30	29	28	27	26	25	24	
Access									
Reset									
	23	22	21	20	19	18	17	16	
						ACKACT	CMD[1:0]		
Access						R/W	W	W	
Reset						0	0	0	
	15	14	13	12	11	10	9	8	
							QCEN	SMEN	
Access							R/W	R/W	
Reset							0	0	
	7	6	5	4	3	2	1	0	
Access									
Reset									

#### Bit 18 – ACKACT Acknowledge Action

This bit defines the I<sup>2</sup>C master's acknowledge behavior after a data byte is received from the I<sup>2</sup>C slave. The acknowledge action is executed when a command is written to CTRLB.CMD, or if Smart mode is enabled (CTRLB.SMEN is written to one), when DATA.DATA is read. This bit is not enable-protected. This bit is not write-synchronized.

Value	Description
0	Send ACK.
1	Send NACK.

#### Bits 17:16 – CMD[1:0] Command

Writing these bits triggers a master operation as described below. The CMD bits are strobe bits, and always read as zero. The acknowledge action is only valid in Master Read mode. In Master Write mode, a command will only result in a repeated Start or Stop condition. The CTRLB.ACKACT bit and the CMD bits can be written at the same time, and then the acknowledge action will be updated before the command is triggered.

Commands can only be issued when either the Slave on Bus Interrupt flag (INTFLAG.SB) or Master on Bus Interrupt flag (INTFLAG.MB) is '1'.

If CMD 0x1 is issued, a repeated start will be issued followed by the transmission of the current address in ADDR.ADDR. If another address is desired, ADDR.ADDR must be written instead of the CMD bits.

This will trigger a repeated start followed by transmission of the new address.

# SAM D5x/E5x Family Data Sheet

## SERCOM I2C – Inter-Integrated Circuit

Issuing a command will set the System Operation bit in the Synchronization Busy register (SYNCBUSY.SYSOP).

**Table 36-4. Command Description**

CMD[1:0]	Direction	Action
0x0	X	(No action)
0x1	X	Execute acknowledge action succeeded by repeated Start
0x2	0 (Write)	No operation
	1 (Read)	Execute acknowledge action succeeded by a byte read operation
0x3	X	Execute acknowledge action succeeded by issuing a Stop condition

These bits are not enable-protected.

### Bit 9 – QCEN Quick Command Enable

This bit is not write-synchronized.

Value	Description
0	Quick Command is disabled.
1	Quick Command is enabled.

### Bit 8 – SMEN Smart Mode Enable

When Smart mode is enabled, acknowledge action is sent when DATA.DATA is read.

This bit is not write-synchronized.

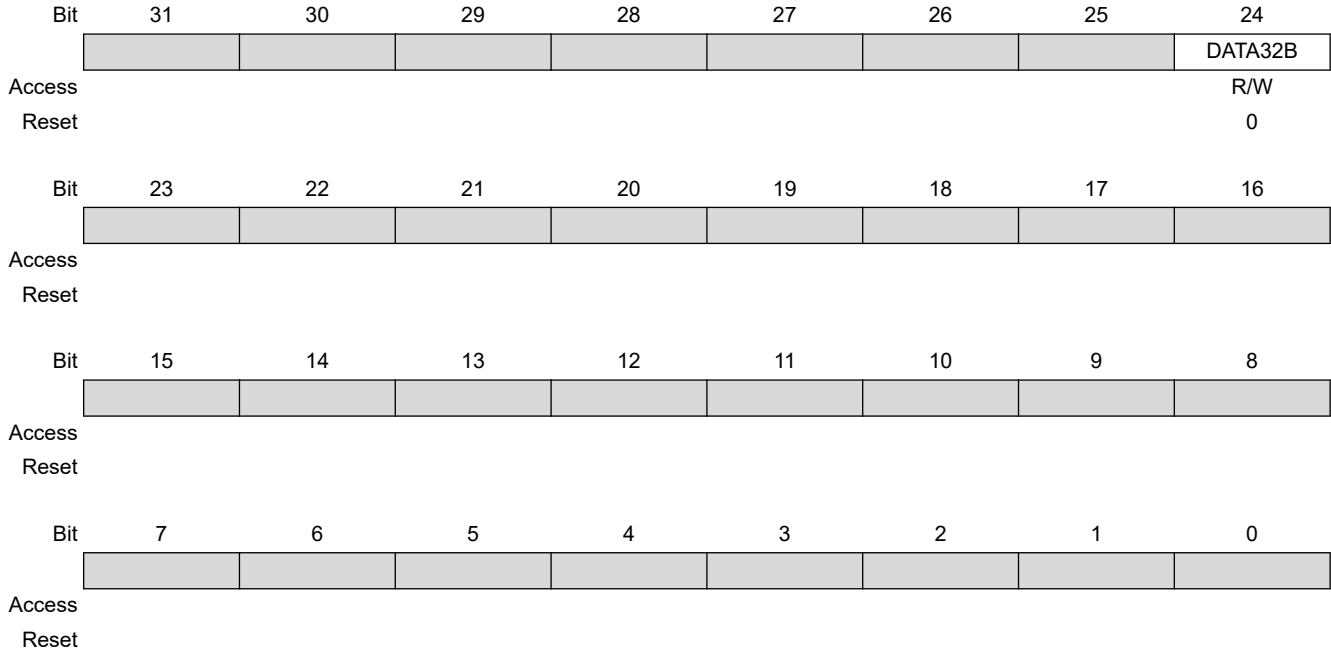
Value	Description
0	Smart mode is disabled.
1	Smart mode is enabled.

# SAM D5x/E5x Family Data Sheet

## SERCOM I2C – Inter-Integrated Circuit

### 36.10.3 Control C

**Name:** CTRLC  
**Offset:** 0x08  
**Reset:** 0x00000000  
**Property:** PAC Write-Protection, Enable-Protected



**Bit 24 – DATA32B** Data 32 Bit

This bit enables 32-bit data writes and reads to/from the DATA register.

Value	Description
0	Data transactions to/from DATA are 8-bit in size
1	Data transactions to/from DATA are 32-bit in size

# SAM D5x/E5x Family Data Sheet

## SERCOM I2C – Inter-Integrated Circuit

### 36.10.4 Baud Rate

**Name:** BAUD  
**Offset:** 0x0C  
**Reset:** 0x0000  
**Property:** PAC Write-Protection, Enable-Protected

	Bit	31	30	29	28	27	26	25	24
		HSBAUDLOW[7:0]							
Access		R/W	R/W	R/W	R/W	R/W	R/W	R/W	R/W
Reset		0	0	0	0	0	0	0	0
	Bit	23	22	21	20	19	18	17	16
		HSBAUD[7:0]							
Access		R/W	R/W	R/W	R/W	R/W	R/W	R/W	R/W
Reset		0	0	0	0	0	0	0	0
	Bit	15	14	13	12	11	10	9	8
		BAUDLOW[7:0]							
Access		R/W	R/W	R/W	R/W	R/W	R/W	R/W	R/W
Reset		0	0	0	0	0	0	0	0
	Bit	7	6	5	4	3	2	1	0
		BAUD[7:0]							
Access		R/W	R/W	R/W	R/W	R/W	R/W	R/W	R/W
Reset		0	0	0	0	0	0	0	0

**Bits 31:24 – HSBAUDLOW[7:0] High Speed Master Baud Rate Low**

HSBAUDLOW non-zero: HSBAUDLOW indicates the SCL low time in High-speed mode according to  $HSBAUDLOW = f_{GCLK} \cdot T_{LOW} - 1$

HSBAUDLOW equal to zero: The HSBAUD register is used to time  $T_{LOW}$ ,  $T_{HIGH}$ ,  $T_{SU;STO}$ ,  $T_{HD;STA}$  and  $T_{SU;STA}$ .  $T_{BUF}$  is timed by the BAUD register.

**Bits 23:16 – HSBAUD[7:0] High Speed Master Baud Rate**

This bit field indicates the SCL high time in High-speed mode according to the following formula. When HSBAUDLOW is zero,  $T_{LOW}$ ,  $T_{HIGH}$ ,  $T_{SU;STO}$ ,  $T_{HD;STA}$  and  $T_{SU;STA}$  are derived using this formula.  $T_{BUF}$  is timed by the BAUD register.

$$HSBAUD = f_{GCLK} \cdot T_{HIGH} - 1$$

**Bits 15:8 – BAUDLOW[7:0] Master Baud Rate Low**

If this bit field is non-zero, the SCL low time will be described by the value written.

For more information on how to calculate the frequency, see SERCOM [33.6.2.3 Clock Generation – Baud-Rate Generator](#).

**Bits 7:0 – BAUD[7:0] Master Baud Rate**

This bit field is used to derive the SCL high time if BAUD.BAUDLOW is non-zero. If BAUD.BAUDLOW is zero, BAUD will be used to generate both high and low periods of the SCL.

For more information on how to calculate the frequency, see SERCOM [33.6.2.3 Clock Generation – Baud-Rate Generator](#).

### 36.10.5 Interrupt Enable Clear

**Name:** INTENCLR  
**Offset:** 0x14  
**Reset:** 0x00  
**Property:** PAC Write-Protection

This register allows the user to disable an interrupt without doing a read-modify-write operation. Changes in this register will also be reflected in the Interrupt Enable Set register (INTENSET).

	7	6	5	4	3	2	1	0
	ERROR						SB	MB
Access	R/W						R/W	R/W
Reset	0						0	0

#### Bit 7 – ERROR Error Interrupt Enable

Writing '0' to this bit has no effect.

Writing '1' to this bit will clear the Error Interrupt Enable bit, which disables the Error interrupt.

Value	Description
0	Error interrupt is disabled.
1	Error interrupt is enabled.

#### Bit 1 – SB Slave on Bus Interrupt Enable

Writing '0' to this bit has no effect.

Writing '1' to this bit will clear the Slave on Bus Interrupt Enable bit, which disables the Slave on Bus interrupt.

Value	Description
0	The Slave on Bus interrupt is disabled.
1	The Slave on Bus interrupt is enabled.

#### Bit 0 – MB Master on Bus Interrupt Enable

Writing '0' to this bit has no effect.

Writing '1' to this bit will clear the Master on Bus Interrupt Enable bit, which disables the Master on Bus interrupt.

Value	Description
0	The Master on Bus interrupt is disabled.
1	The Master on Bus interrupt is enabled.



### 36.10.6 Interrupt Enable Set

**Name:** INTENSET  
**Offset:** 0x16  
**Reset:** 0x00  
**Property:** PAC Write-Protection

This register allows the user to enable an interrupt without doing a read-modify-write operation. Changes in this register will also be reflected in the Interrupt Enable Clear register (INTENCLR).

Bit	7	6	5	4	3	2	1	0
	ERROR						SB	MB
Access	R/W						R/W	R/W
Reset	0						0	0

**Bit 7 – ERROR** Error Interrupt Enable

Writing '0' to this bit has no effect.

Writing '1' to this bit will set the Error Interrupt Enable bit, which enables the Error interrupt.

Value	Description
0	Error interrupt is disabled.
1	Error interrupt is enabled.

**Bit 1 – SB** Slave on Bus Interrupt Enable

Writing '0' to this bit has no effect.

Writing '1' to this bit will set the Slave on Bus Interrupt Enable bit, which enables the Slave on Bus interrupt.

Value	Description
0	The Slave on Bus interrupt is disabled.
1	The Slave on Bus interrupt is enabled.

**Bit 0 – MB** Master on Bus Interrupt Enable

Writing '0' to this bit has no effect.

Writing '1' to this bit will set the Master on Bus Interrupt Enable bit, which enables the Master on Bus interrupt.

Value	Description
0	The Master on Bus interrupt is disabled.
1	The Master on Bus interrupt is enabled.

### 36.10.7 Interrupt Flag Status and Clear

**Name:** INTFLAG  
**Offset:** 0x18  
**Reset:** 0x00  
**Property:** -

	7	6	5	4	3	2	1	0
	ERROR						SB	MB
Access	R/W						R/W	R/W
Reset	0						0	0

#### Bit 7 – ERROR Error

This flag is cleared by writing '1' to it.

This bit is set when any error is detected. Errors that will set this flag have corresponding status bits in the STATUS register. These status bits are LENERR, SEXTTOUT, MEXTTOUT, LOWTOUT, ARBLOST, and BUSERR.

Writing '0' to this bit has no effect.

Writing '1' to this bit will clear the flag.

#### Bit 1 – SB Slave on Bus

The Slave on Bus flag (SB) is set when a byte is successfully received in Master Read mode, for example, no arbitration lost or bus error occurred during the operation. When this flag is set, the master forces the SCL line low, stretching the I<sup>2</sup>C clock period. The SCL line will be released and SB will be cleared on one of the following actions:

- Writing to ADDR.ADDR
- Writing to DATA.DATA
- Reading DATA.DATA when Smart mode is enabled (CTRLB.SMEN)
- Writing a valid command to CTRLB.CMD

Writing '1' to this bit location will clear the SB flag. The transaction will not continue or be terminated until one of the above actions is performed.

Writing '0' to this bit has no effect.

#### Bit 0 – MB Master on Bus

This flag is set when a byte is transmitted in Master Write mode. The flag is set regardless of the occurrence of a bus error or an Arbitration Lost condition. MB is also set when arbitration is lost during sending of NACK in Master Read mode, or when issuing a Start condition if the bus state is unknown. When this flag is set and arbitration is not lost, the master forces the SCL line low, stretching the I<sup>2</sup>C clock period. The SCL line will be released and MB will be cleared on one of the following actions:

- Writing to ADDR.ADDR
- Writing to DATA.DATA
- Reading DATA.DATA when Smart mode is enabled (CTRLB.SMEN)
- Writing a valid command to CTRLB.CMD

Writing '1' to this bit location will clear the MB flag. The transaction will not continue or be terminated until one of the above actions is performed.

Writing '0' to this bit has no effect.

# SAM D5x/E5x Family Data Sheet

## SERCOM I2C – Inter-Integrated Circuit

### 36.10.8 Status

**Name:** STATUS  
**Offset:** 0x1A  
**Reset:** 0x0000  
**Property:** Write-Synchronized

	Bit	15	14	13	12	11	10	9	8
							LENERR	SEXTTOUT	MEXTTOUT
Access							R/W	R/W	R/W
Reset							0	0	0
	Bit	7	6	5	4	3	2	1	0
		CLKHOLD	LOWTOUT	BUSSTATE[1:0]			RXNACK	ARBLOST	BUSERR
Access		R	R/W	R/W	R/W		R	R/W	R/W
Reset		0	0	0	0		0	0	0

**Bit 10 – LENERR** Transaction Length Error

This bit is set when automatic length is used for a DMA and/or 32-bit transaction and the slave sends a NACK before ADDR.LEN bytes have been written by the master.

Writing '1' to this bit location will clear STATUS.LENERR. This flag is automatically cleared when writing to the ADDR register.

Writing '0' to this bit has no effect.

This bit is not write-synchronized.

**Bit 9 – SEXTTOUT** Slave SCL Low Extend Time-Out

This bit is set if a slave SCL low extend time-out occurs.

This bit is automatically cleared when writing to the ADDR register.

Writing '1' to this bit location will clear SEXTTOUT. Normal use of the I<sup>2</sup>C interface does not require the SEXTTOUT flag to be cleared by this method.

Writing '0' to this bit has no effect.

This bit is not write-synchronized.

**Bit 8 – MEXTTOUT** Master SCL Low Extend Time-Out

This bit is set if a master SCL low time-out occurs.

Writing '1' to this bit location will clear STATUS.MEXTTOUT. This flag is automatically cleared when writing to the ADDR register.

Writing '0' to this bit has no effect.

This bit is not write-synchronized.

**Bit 7 – CLKHOLD** Clock Hold

This bit is set when the master is holding the SCL line low, stretching the I<sup>2</sup>C clock. Software should consider this bit when INTFLAG.SB or INTFLAG.MB is set.

This bit is cleared when the corresponding Interrupt flag is cleared and the next operation is given.

Writing '0' to this bit has no effect.

Writing '1' to this bit has no effect.

This bit is not write-synchronized.

# SAM D5x/E5x Family Data Sheet

## SERCOM I2C – Inter-Integrated Circuit

### Bit 6 – LOWTOUT SCL Low Time-Out

This bit is set if an SCL low time-out occurs.

Writing '1' to this bit location will clear this bit. This flag is automatically cleared when writing to the ADDR register.

Writing '0' to this bit has no effect.

This bit is not write-synchronized.

### Bits 5:4 – BUSSTATE[1:0] Bus State

These bits indicate the current I<sup>2</sup>C Bus state.

When in UNKNOWN state, writing 0x1 to BUSSTATE forces the bus state into the IDLE state. The bus state cannot be forced into any other state.

Writing BUSSTATE to idle will set SYNCBUSY.SYSOP.

Value	Name	Description
0x0	UNKNOWN	The Bus state is unknown to the I <sup>2</sup> C master and will wait for a Stop condition to be detected or wait to be forced into an Idle state by software
0x1	IDLE	The Bus state is waiting for a transaction to be initialized
0x2	OWNER	The I <sup>2</sup> C master is the current owner of the bus
0x3	BUSY	Some other I <sup>2</sup> C master owns the bus

### Bit 2 – RXNACK Received Not Acknowledge

This bit indicates whether the last address or data packet sent was acknowledged or not.

Writing '0' to this bit has no effect.

Writing '1' to this bit has no effect.

This bit is not write-synchronized.

Value	Description
0	Slave responded with ACK.
1	Slave responded with NACK.

### Bit 1 – ARBLOST Arbitration Lost

This bit is set if arbitration is lost while transmitting a high data bit or a NACK bit, or while issuing a Start or Repeated Start condition on the bus. The Master on Bus Interrupt flag (INTFLAG.MB) will be set when STATUS.ARBLOST is set.

Writing the ADDR.ADDR register will automatically clear STATUS.ARBLOST.

Writing '0' to this bit has no effect.

Writing '1' to this bit will clear it.

This bit is not write-synchronized.

### Bit 0 – BUSERR Bus Error

This bit indicates that an illegal Bus condition has occurred on the bus, regardless of bus ownership. An illegal Bus condition is detected if a protocol violating start, repeated start or stop is detected on the I<sup>2</sup>C bus lines. A Start condition directly followed by a Stop condition is one example of a protocol violation. If a time-out occurs during a frame, this is also considered a protocol violation, and will set BUSERR.

If the I<sup>2</sup>C master is the bus owner at the time a bus error occurs, STATUS.ARBLOST and INTFLAG.MB will be set in addition to BUSERR.

Writing the ADDR.ADDR register will automatically clear the BUSERR flag.

Writing '0' to this bit has no effect.

Writing '1' to this bit will clear it.

This bit is not write-synchronized.

# SAM D5x/E5x Family Data Sheet

## SERCOM I2C – Inter-Integrated Circuit

### 36.10.9 Synchronization Busy

**Name:** SYNCBUSY  
**Offset:** 0x1C  
**Reset:** 0x00000000

	Bit	31	30	29	28	27	26	25	24	
		<div style="display: flex; justify-content: space-between; width: 100%; height: 15px; background-color: #cccccc;"></div>								
Access										
Reset										
	Bit	23	22	21	20	19	18	17	16	
		<div style="display: flex; justify-content: space-between; width: 100%; height: 15px; background-color: #cccccc;"></div>								
Access										
Reset										
	Bit	15	14	13	12	11	10	9	8	
		<div style="display: flex; justify-content: space-between; width: 100%; height: 15px; background-color: #cccccc;"></div>								
Access										
Reset										
	Bit	7	6	5	4	3	2	1	0	
		<div style="display: flex; justify-content: space-between; width: 100%; height: 15px; background-color: #cccccc;"></div>					SYSOP	ENABLE	SWRST	
Access							R	R	R	
Reset							0	0	0	

**Bit 2 – SYSOP** System Operation Synchronization Busy

Writing CTRLB.COMD, STATUS.BUSSTATE, ADDR, or DATA when the SERCOM is enabled requires synchronization. When written, the SYNCBUSY.SYSOP bit will be set until synchronization is complete.

Value	Description
0	System operation synchronization is not busy.
1	System operation synchronization is busy.

**Bit 1 – ENABLE** SERCOM Enable Synchronization Busy

Enabling and disabling the SERCOM (CTRLA.ENABLE) requires synchronization. When written, the SYNCBUSY.ENABLE bit will be set until synchronization is complete.

Value	Description
0	Enable synchronization is not busy.
1	Enable synchronization is busy.

**Bit 0 – SWRST** Software Reset Synchronization Busy

Resetting the SERCOM (CTRLA.SWRST) requires synchronization. When written, the SYNCBUSY.SWRST bit will be set until synchronization is complete.

Value	Description
0	SWRST synchronization is not busy.
1	SWRST synchronization is busy.

# SAM D5x/E5x Family Data Sheet

## SERCOM I2C – Inter-Integrated Circuit

### 36.10.10 Address

**Name:** ADDR  
**Offset:** 0x24  
**Reset:** 0x0000  
**Property:** Write-Synchronized

	31	30	29	28	27	26	25	24
	[Greyed out bits 31:24]							
Access								
Reset								
	23	22	21	20	19	18	17	16
	LEN[7:0]							
Access	R/W	R/W	R/W	R/W	R/W	R/W	R/W	R/W
Reset	0	0	0	0	0	0	0	0
	15	14	13	12	11	10	9	8
	TENBITEN	HS	LENEN	[Greyed out bits 12:11]		ADDR[10:8]		
Access	R/W	R/W	R/W			R/W	R/W	R/W
Reset	0	0	0			0	0	0
	7	6	5	4	3	2	1	0
	ADDR[7:0]							
Access	R/W	R/W	R/W	R/W	R/W	R/W	R/W	R/W
Reset	0	0	0	0	0	0	0	0

#### Bits 23:16 – LEN[7:0] Transaction Length

These bits define the transaction length of a DMA and/or 32-bit transaction from 0 to 255 bytes. The Transfer Length Enable (LENEN) bit must be written to '1' in order to use DMA.

#### Bit 15 – TENBITEN Ten Bit Addressing Enable

This bit enables 10-bit addressing. This bit can be written simultaneously with ADDR to indicate a 10-bit or 7-bit address transmission.

Value	Description
0	10-bit addressing disabled.
1	10-bit addressing enabled.

#### Bit 14 – HS High Speed

This bit enables High-speed mode for the current transfer from repeated START to STOP. This bit can be written simultaneously with ADDR for a high speed transfer.

Value	Description
0	High-speed transfer disabled.
1	High-speed transfer enabled.

#### Bit 13 – LENEN Transfer Length Enable

Value	Description
0	Automatic transfer length disabled.
1	Automatic transfer length enabled.

# SAM D5x/E5x Family Data Sheet

## SERCOM I2C – Inter-Integrated Circuit

---

### **Bits 10:0 – ADDR[10:0] Address**

When ADDR is written, the consecutive operation will depend on the bus state:

**UNKNOWN:** INTFLAG.MB and STATUS.BUSERR are set, and the operation is terminated.

**BUSY:** The I<sup>2</sup>C master will await further operation until the bus becomes IDLE.

**IDLE:** The I<sup>2</sup>C master will issue a start condition followed by the address written in ADDR. If the address is acknowledged, SCL is forced and held low, and STATUS.CLKHOLD and INTFLAG.MB are set.

**OWNER:** A repeated start sequence will be performed. If the previous transaction was a read, the acknowledge action is sent before the repeated start bus condition is issued on the bus. Writing ADDR to issue a repeated start is performed while INTFLAG.MB or INTFLAG.SB is set.

STATUS.BUSERR, STATUS.ARBLOST, INTFLAG.MB and INTFLAG.SB will be cleared when ADDR is written.

The ADDR register can be read at any time without interfering with ongoing bus activity, as a read access does not trigger the master logic to perform any bus protocol related operations.

The I<sup>2</sup>C master control logic uses bit 0 of ADDR as the bus protocol's read/write flag (R/W); 0 for write and 1 for read.

# SAM D5x/E5x Family Data Sheet

## SERCOM I2C – Inter-Integrated Circuit

### 36.10.11 Data

**Name:** DATA  
**Offset:** 0x28  
**Reset:** 0x00000000  
**Property:** Read/Write

	Bit	31	30	29	28	27	26	25	24
		DATA[31:24]							
Access		R/W	R/W	R/W	R/W	R/W	R/W	R/W	R/W
Reset		0	0	0	0	0	0	0	0
	Bit	23	22	21	20	19	18	17	16
		DATA[23:16]							
Access		R/W	R/W	R/W	R/W	R/W	R/W	R/W	R/W
Reset		0	0	0	0	0	0	0	0
	Bit	15	14	13	12	11	10	9	8
		DATA[15:8]							
Access		R/W	R/W	R/W	R/W	R/W	R/W	R/W	R/W
Reset		0	0	0	0	0	0	0	0
	Bit	7	6	5	4	3	2	1	0
		DATA[7:0]							
Access		R/W	R/W	R/W	R/W	R/W	R/W	R/W	R/W
Reset		0	0	0	0	0	0	0	0

#### Bits 31:0 – DATA[31:0] Data

The master data register I/O location (DATA) provides access to the master transmit and receive data buffers. Reading valid data or writing data to be transmitted can be successfully done only when SCL is held low by the master (STATUS.CLKHOLD is set). An exception is reading the last data byte after the stop condition has been sent.

Accessing DATA.DATA auto-triggers I<sup>2</sup>C bus operations. The operation performed depends on the state of CTRLB.ACKACT, CTRLB.SMEN and the type of access (read/write).

When CTRLC.DATA32B=1, read and write transactions from/to the DATA register are 32 bit in size. Otherwise, reads and writes are 8 bit.



# SAM D5x/E5x Family Data Sheet

## SERCOM I2C – Inter-Integrated Circuit

### 36.10.12 Debug Control

**Name:** DBGCTRL  
**Offset:** 0x30  
**Reset:** 0x00  
**Property:** PAC Write-Protection

Bit	7	6	5	4	3	2	1	0
								DBGSTOP
Access								R/W
Reset								0

#### Bit 0 – DBGSTOP Debug Stop Mode

This bit controls functionality when the CPU is halted by an external debugger.

Value	Description
0	The baud-rate generator continues normal operation when the CPU is halted by an external debugger.
1	The baud-rate generator is halted when the CPU is halted by an external debugger.

### 37. QSPI - Quad Serial Peripheral Interface

#### 37.1 Overview

The Quad SPI Interface (QSPI) circuit is a synchronous serial data link that provides communication with external devices in Master mode.

The QSPI can be used in “SPI mode” to interface serial peripherals, such as ADCs, DACs, LCD controllers and sensors, or in “Serial Memory Mode” to interface serial Flash memories.

The QSPI allows the system to execute code directly from a serial Flash memory (XIP) without code shadowing to SRAM. The serial Flash memory mapping is seen in the system as other memories (ROM, SRAM, DRAM, embedded Flash memories, etc.,).

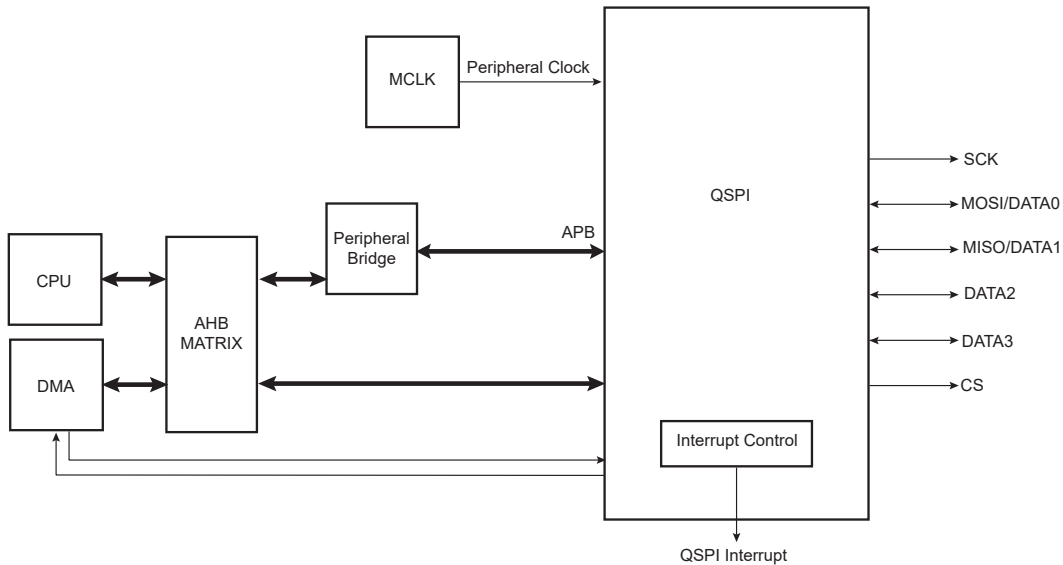
With the support of the quad-SPI protocol, the QSPI allows the system to use high performance serial Flash memories which are small and inexpensive, in place of larger and more expensive parallel Flash memories.

#### 37.2 Features

- Master SPI Interface:
  - Programmable Clock Phase and Clock Polarity
  - Programmable transfer delays between consecutive transfers, between clock and data, between deactivation and activation of chip select (CS)
- SPI Mode:
  - To use serial peripherals, such as ADCs, DACs, LCD controllers, CAN controllers, and sensors
  - 8-bit, 16-bit, or 32-bit programmable data length
- Serial Memory Mode:
  - To use serial Flash memories operating in single-bit SPI, Dual SPI and Quad SPI
  - Supports “execute in place” (XIP). The system can execute code directly from a Serial Flash memory.
  - Flexible Instruction register, to be compatible with all Serial Flash memories
  - 32-bit Address mode (default is 24-bit address) to support Serial Flash memories larger than 128 Mbit
  - Continuous Read mode
  - Scrambling/Unscrambling “On-the-Fly”
  - Double data rate support
- Connection to DMA Channel Capabilities Optimizes Data Transfers
  - One channel for the receiver and one channel for the transmitter
- Register Write Protection

### 37.3 Block Diagram

Figure 37-1. QSPI Block Diagram



### 37.4 Signal Description

Table 37-1. Quad-SPI Signals

Signal	Description	Type
SCK	Serial Clock	Output
CS	Chip Select	Output
MOSI(DATA0)	Data Output (Data Input Output 0)	Output (Input/Output)
MISO(DATA1)	Data Input (Data Input Output 1)	Input (Input/Output)
DATA2	Data Input Output 2	Input/Output
DATA3	Data Input Output 3	Input/Output

**Note:** MOSI and MISO are used for single-bit SPI operation

**Note:** DATA0-DATA1 are used for Dual SPI operation

**Note:** DATA0-DATA3 are used for Quad SPI operation

Refer to the pinout table for details on the pin mapping for this peripheral. One signal can be mapped to one of several pins.

### 37.5 Product Dependencies

In order to use this peripheral, other parts of the system must be configured correctly, as described below.

#### 37.5.1 I/O Lines

Using the QSPI I/O lines requires the I/O pins to be configured.

### Related Links

[32. PORT - I/O Pin Controller](#)

### 37.5.2 Power Management

The QSPI will continue to operate in any Sleep mode where the selected source clock is running. The QSPI interrupts can be used to wake up the device from sleep modes. Refer to the Power Manager chapter for details on the different sleep modes.

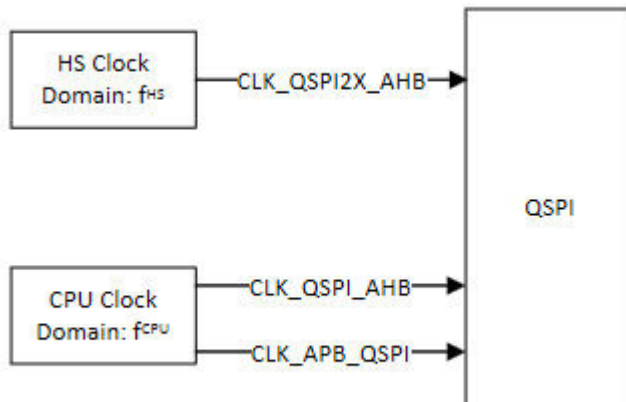
### 37.5.3 Clocks

The QSPI bus clock (CLK\_QSPI\_APB) can be enabled and disabled in the Main Clock module, and the default state of CLK\_QSPI\_APB can be found in the Peripheral Clock Masking section in the MCLK chapter.

An AHB clock (CLK\_QSPI\_AHB) is required to clock the QSPI. This clock can be enabled and disabled in the Main Clock module, and the default state of CLK\_QSPI\_AHB can be found in the Peripheral Clock Masking section in the MCLK chapter.

A FAST clock (CLK\_QSPI2X\_AHB) is required to clock the QSPI. This clock can be enabled and disabled in the Main Clock module, and the default state of CLK\_QSPI2X\_AHB can be found in the Peripheral Clock Masking section in the MCLK chapter. This clock is derived from the High-Speed Clock Domain (HS Clock Domain, frequency  $f_{HS}$ ).

**Figure 37-2. QSPI Clock Organization**



**Important:** The CLK\_QSPI2x\_AHB must be 2 times faster to CLK\_QSPI\_AHB when the QSPI is operated in DDR mode. In SDR, the CLK\_QSPI2x\_AHB is not used.

CLK\_QSPI\_APB, CLK\_QSPI\_AHB, and CLK\_QSPI2X\_AHB, respectively, are all synchronous, but can be divided by a prescaler and may run even when the module clock is turned off.

### Related Links

[15. MCLK – Main Clock](#)

[15.6.2.6 Peripheral Clock Masking](#)

### 37.5.4 DMA

The DMA request lines are connected to the DMA Controller (DMAC). Using the QSPI DMA requests requires the DMA Controller to be configured first.

**Note:** DMAC write access must be 32-bit aligned. If a single byte is to be written in a 32-bit word, the rest of the word must be filled with 'ones'.

#### Related Links

[22. DMAC – Direct Memory Access Controller](#)

### 37.5.5 Interrupts

The interrupt request lines are connected to the interrupt controller. Using the QSPI interrupts requires the interrupt controller to be configured first. Refer to the Nested Vector Interrupt Controller section for details.

#### Related Links

[10.2 Nested Vector Interrupt Controller](#)

### 37.5.6 Events

Not applicable.

### 37.5.7 Debug Operation

When the CPU is halted in debug mode the QSPI continues normal operation. If the QSPI is configured in a way that requires it to be periodically serviced by the CPU through interrupts or similar, improper operation or data loss may result during debugging.

### 37.5.8 Register Access Protection

All registers with write-access are optionally write-protected by the peripheral access controller (PAC), except the following registers:

- Control A (CTRLA) register
- Transmit Data (TXDATA) register
- Interrupt Flag Status and Clear (INTFLAG) register
- Interrupt Flag Status and Clear (INTFLAG) register

PAC write-protection is denoted by the 'PAC Write-Protection' property in the register description.

Write-protection does not apply to accesses through an external debugger.

## 37.6 Functional Description

### 37.6.1 Principle of Operation

The QSPI is a high-speed synchronous data transfer interface. It allows high-speed communication between the device and peripheral or serial memory devices.

The QSPI operates as a master. It initiates and controls all data transactions.

When transmitting, the TXDATA register can be loaded with the next character to be transmitted during the current transmission.

When receiving, the data is transferred to the RXDATA register, and the receiver is ready for a new character.

### 37.6.2 Basic Operation

#### 37.6.2.1 Initialization

After Power-On Reset, this peripheral is enabled .

#### 37.6.2.2 Enabling, Disabling, and Resetting

The peripheral is enabled by writing a '1' to the Enable bit in the Control A register (CTRLA.ENABLE).

The peripheral is disabled by writing a '0' to CTRLA.ENABLE.

The peripheral is reset by writing a '1' to the Software Reset bit (CTRLA.SWRST).

### 37.6.3 Transfer Data Rate

By default, the QSPI module is enabled in single data rate mode. In this operating mode, the CLK\_QSPI2X\_AHB clock is not used and can be disabled.

The dual data rate operating mode is enabled by writing a '1' to the Double Data Rate Enable bit in the Instruction Frame register (INSTRFRAME.DDREN). This operating mode requires the CLK\_QSPI2X\_AHB clock and must be enabled before writing the DDREN bit.

### 37.6.4 Serial Clock Baudrate

The QSPI Baud rate clock is generated by dividing the module clock (CLK\_QSPI\_AHB) by a value between 1 and 255.

This allows a maximum operating baud rate at up to Master Clock and a minimum operating baud rate of CLK\_QSPI\_AHB divided by 256.

### 37.6.5 Serial Clock Phase and Polarity

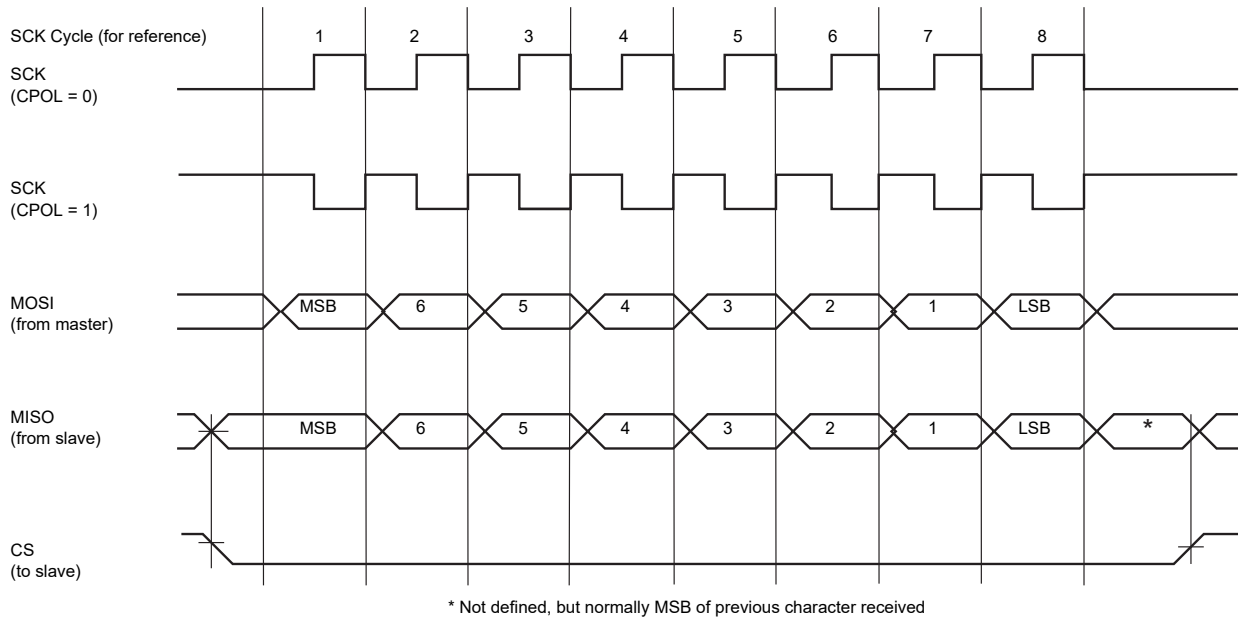
Four combinations of polarity and phase are available for data transfers. Writing the Clock Polarity bit in the QSPI Baud register (BAUD.CPOL) selects the polarity. The Clock Phase bit in the BAUD register programs the clock phase (BAUD.CPHA). These two parameters determine the edges of the clock signal on which data is driven and sampled. Each of the two parameters has two possible states, resulting in four possible combinations

**Note:** The polarity/phase combinations are incompatible. Thus, the interfaced slave must use the same parameter values to communicate.

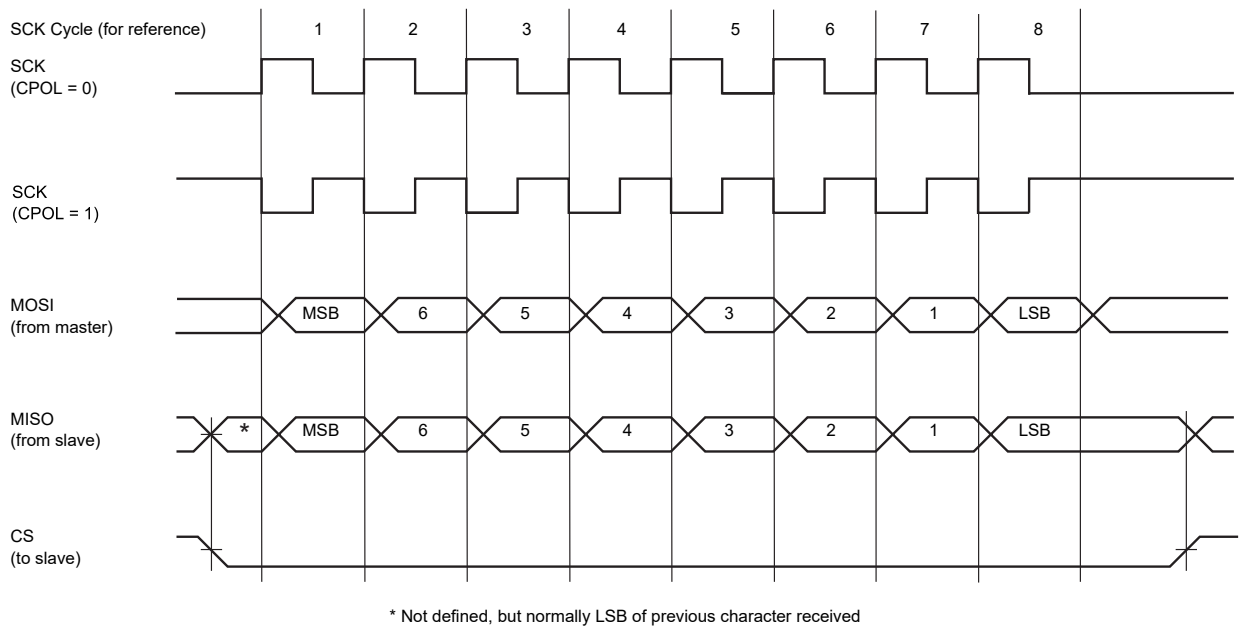
**Table 37-2. SPI Transfer Mode**

Clock Mode	BAUD.CPOL	BAUD.CPHA	Shift SCK Edge	Capture SCK Edge	SCK Inactive Level
0	0	0	Falling	Rising	Low
1	0	1	Rising	Falling	Low
2	1	0	Rising	Falling	High
3	1	1	Falling	Rising	High

**Figure 37-3. QSPI Transfer Modes (BAUD.CPHA = 0, 8-bit transfer)**



**Figure 37-4. QSPI Transfer Modes (BAUD.CPHA = 1, 8-bit transfer)**



### 37.6.6 Transfer Delays

The QSPI supports several consecutive transfers while the chip select is active. Three delays can be programmed to modify the transfer waveforms:

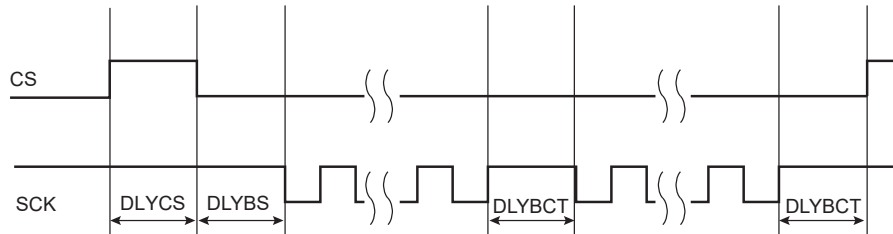
- The delay between the inactivation and the activation of CS is programmed by writing the Minimum Inactive CS Delay bit field in the Control B register (CTRLB.DLYCS), allowing to tune the minimum time of CS at high level.
- The delay between consecutive transfers is programmed by writing the Delay Between Consecutive Transfers bit field in the Control B register (CTRLB.DLYBCT), allowing to insert a delay between two

consecutive transfers. In Serial Memory mode, this delay is not programmable and DLYBCT settings are ignored.

- The delay before SCK is programmed by writing the Delay Before SCK bit field in the BAUD register (BAUD.DLYBS), allowing to delay the start of SPCK after the chip select has been asserted.

These delays allow the QSPI to be adapted to the interfaced peripherals and their speed and bus release time.

**Figure 37-5. Programmable Delay**



### 37.6.7 QSPI SPI Mode

In this mode, the QSPI acts as a regular SPI Master.

To activate this mode, the MODE bit in Control B register must be cleared (CTRLB.MODE=0).

#### 37.6.7.1 SPI Mode Operations

The QSPI in standard SPI mode operates on the clock generated by the internal programmable baud rate generator. It fully controls the data transfers to and from the slave connected to the SPI bus. The QSPI drives the chip select line to the slave (CS) and the serial clock signal (SCK).

The QSPI features a single internal shift register and two holding registers: the Transmit Data Register (TXDATA) and the Receive Data Register (RXDATA). The holding registers maintain the data flow at a constant rate.

After enabling the QSPI, a data transfer begins when the processor writes to the TXDATA. The written data is immediately transferred into the internal shift register and transfer on the SPI bus starts. While the data in the internal shift register is shifted on the MOSI line, the MISO line is sampled and shifted into the internal shift register. Receiving data cannot occur without transmitting data.

If new data is written in TXDATA during the transfer, it stays in TXDATA until the current transfer is completed. Then, the received data is transferred from the internal shift register to the RXDATA, the data in TXDATA is loaded into the internal shift register, and a new transfer starts.

The transfer of data written in TXDATA in the internal shift register is indicated by the Transmit Data Register Empty (DRE) bit in the Interrupt Flag Status and Clear register (INTFLAG.DRE). When new data is written in TXDATA, this bit is cleared. The DRE bit is used to trigger the Transmit DMA channel.

The end of transfer is indicated by the Transmission Complete flag (INTFLAG.TXC). If the transfer delay for the last transfer was configured to be greater than 0 (CTRLB.DLYBCT), TXC is set after the completion of the delay. The module clock (CLK\_QSPI\_AHB) can be switched off at this time.

Ongoing transfer of received data from the internal shift register into RXDATA is indicated by the Receive Data Register Full flag (INTFLAG.RXC). When the received data is read, the RXC bit is cleared.

If the RXDATA has not been read before new data is received, the Overrun Error flag in INTFLAG register (INTFLAG.ERROR) is set. As long as this flag is set, data is loaded in RXDATA.

The SPI Mode Block Diagram shows a flow chart describing how transfers are handled.

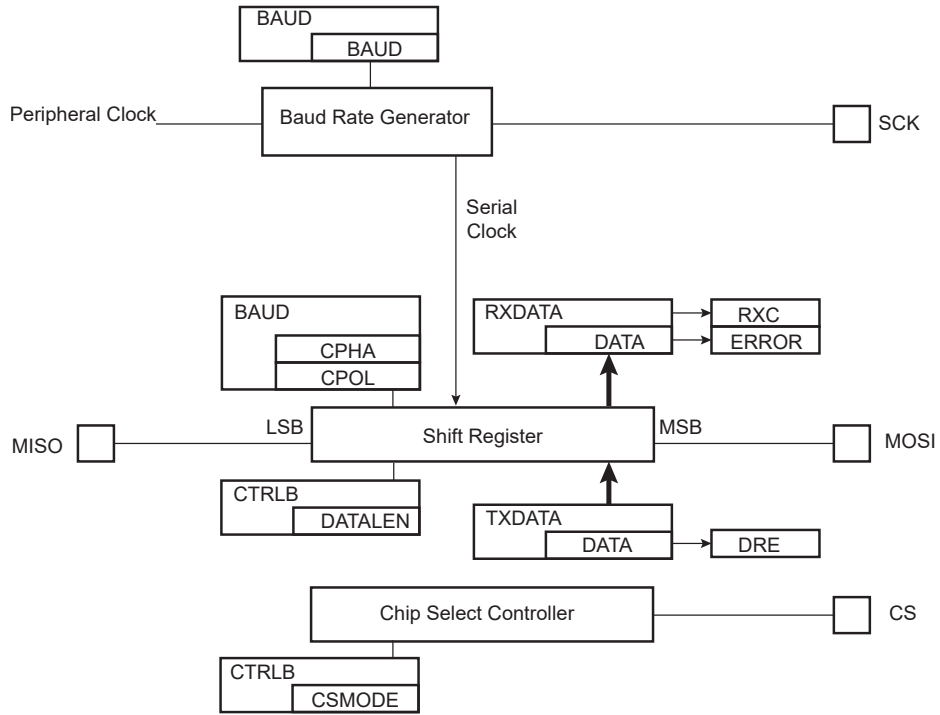


# SAM D5x/E5x Family Data Sheet

## QSPI - Quad Serial Peripheral Interface

### 37.6.7.2 SPI Mode Block Diagram

**Figure 37-6. SPI Mode Block Diagram**

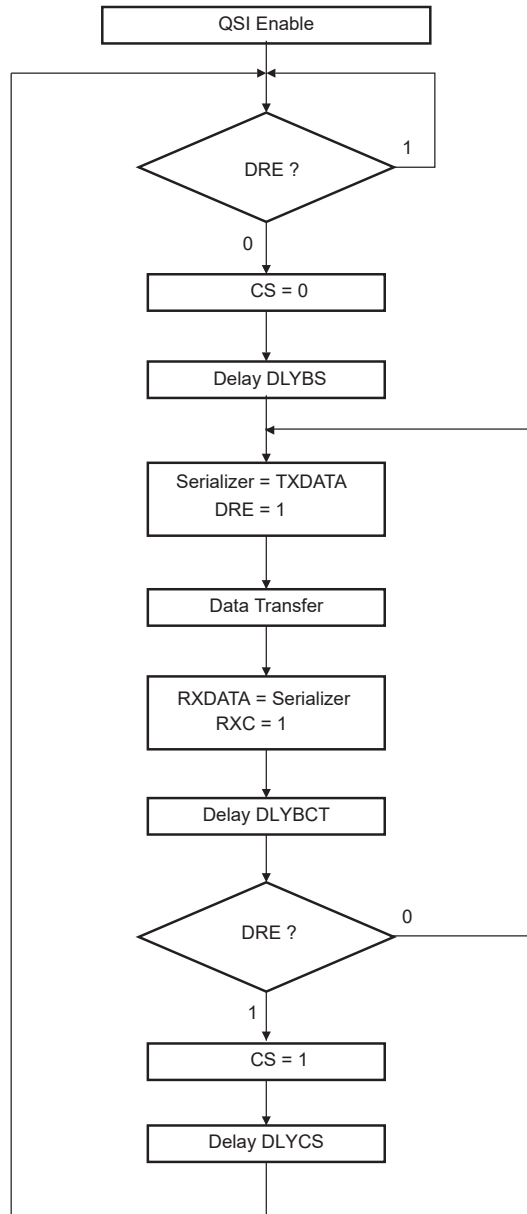


# SAM D5x/E5x Family Data Sheet

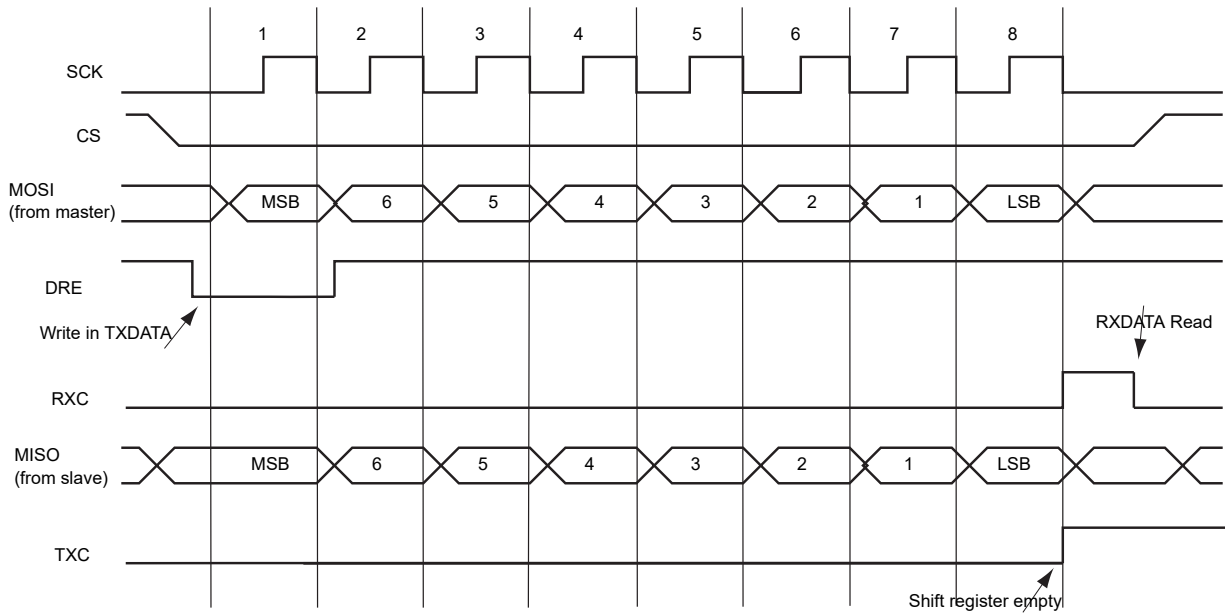
## QSPI - Quad Serial Peripheral Interface

### 37.6.7.3 SPI Mode Flow Diagram

Figure 37-7. SPI Mode Flow Diagram



**Figure 37-8. Interrupt Flags Behaviour**



### 37.6.7.4 Peripheral Deselection with DMA

When the Direct Memory Access Controller is used, the Chip Select line will remain low during the whole transfer since the Transmit Data Register Empty flag in the Interrupt Flag Status and Clear register (INTFLAG.DRE) is managed by the DMA itself. The reloading of the TXDATA by the DMA is done as soon as INTFLAG.DRE flag is set. In this case, setting the Chip Select Mode bit field in the Control B register (CTRLB.CSMODE) to 0x1 is not mandatory.

However, it may happen that when other DMA channels connected to other peripherals are in use as well, the QSPI DMA could be delayed by another DMA transfer with a higher priority on the bus. Having DMA buffers in slower memories like flash memory or SDRAM (compared to fast internal SRAM), may lengthen the reload time of the TXDATA by the DMA as well. This means that TXDATA might not be reloaded in time to keep the Chip Select line low. In this case the Chip Select line may toggle between data transfer and according to some SPI Slave devices, and the communication might get lost. Writing CTRLB.CSMODE=0x1 can prevent this loss.

When CTRLB.CSMODE=0x0, the CS does not rise in all cases between two transfers on the same peripheral. During a transfer on a Chip Select, the INTFLAG.DRE flag is raised as soon as the content of the TXDATA is transferred into the internal shifter. When this flag is detected the TXDATA can be reloaded. If this reload occurs before the end of the current transfer and if the next transfer is performed on the same Chip Select as the current transfer, the Chip Select is not de-asserted between the two transfers. This may lead to difficulties for interfacing with some serial peripherals requiring the Chip Select to be de-asserted after each transfer. To facilitate interfacing with such devices, it is recommended to write CTRLB.CSMODE to 0x2.

### 37.6.7.5 Peripheral Deselection without DMA

During multiple data transfers on a Chip Select without the DMA, the TXDATA is loaded by the processor, and the Transmit Data Register Empty flag in the Interrupt Flag Status and Clear register (INTFLAG.DRE) rises as soon as the content of the RXDATA is transferred into the internal shift register. When this flag is detected high, the TXDATA can be reloaded. If this reload-by-processor occurs before the end of the current transfer and if the next transfer is performed on the same Chip Select as the current transfer, the Chip Select is not de-asserted between the two transfers.

Depending on the application software handling the flags or servicing other interrupts or other tasks, the processor may not reload the TXDATA in time to keep the Chip Select active (low). A null Delay Between Consecutive Transfer bit field value in the CTRLB register (CTRLB.DLYBCT) will give even less time for the processor to reload the TXDATA. With some SPI slave peripherals, requiring the Chip Select line to remain active (low) during a full set of transfers might lead to communication errors.

To facilitate interfacing with such devices, the Chip Select Mode bit field in the CTRLB register (CTRLB.CSMODE) can be written to 0x1. This allows the Chip Select lines to remain in their current state (low = active) until the end of transfer is indicated by the Last Transfer bit in the CTRLA register (CTRLA.LASTXFER). Even if the TXDATA is not reloaded the Chip Select will remain active. To have the Chip Select line rise at the end of the last data transfer, the LASTXFER bit in the CTRLA must be set before writing the last data to transmit into the TXDATA.

### 37.6.8 QSPI Serial Memory Mode

In this mode the QSPI acts as a serial flash memory controller. The QSPI can be used to read data from the serial flash memory allowing the CPU to execute code from it (XIP execute in place). The QSPI can also be used to control the serial flash memory (Program, Erase, Lock, etc.) by sending specific commands. In this mode, the QSPI is compatible with single-bit SPI, Dual SPI and Quad SPI protocols.

To activate this mode, the MODE bit in Control B register must be set to one (CTRLB.MODE = 1).

In serial memory mode, data cannot be transferred by the TXDATA and the RXDATA, but by writing or reading the QSPI memory space (0x0400 0000 – 0x0500 0000).

#### 37.6.8.1 Instruction Frame

In order to control serial flash memories, the QSPI is able to sent instructions by the SPI bus (ex: READ, PROGRAM, ERASE, LOCK, etc.). Because instruction set implemented in serial flash memories is memory vendor dependant, the QSPI includes a complete instruction registers, which makes it very flexible and compatible with all serial flash memories.

An instruction frame includes:

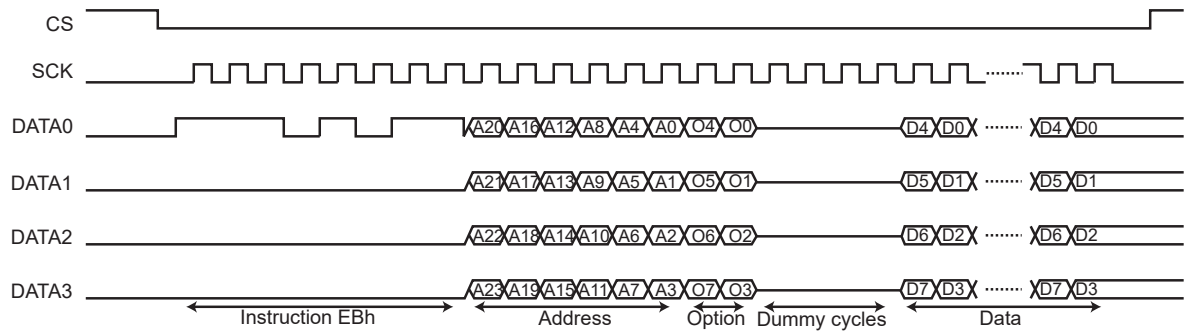
- An instruction code (size: 8 bits). The instruction can be optional in some cases.
- An address (size: 24 bits or 32 bits). The address is optional but is required by instructions such as READ, PROGRAM, ERASE, LOCK. By default the address is 24 bits long, but it can be 32 bits long to support serial flash memories larger than 128 Mbit (16 Mbyte).
- An option code (size: 1/2/4/8 bits). The option code is optional but is useful for activate the “XIP mode” or the “Continuous Read Mode” for READ instructions, in some serial flash memory devices. These modes allow to improve the data read latency.
- Dummy cycles. Dummy cycles are optional but required by some READ instructions.
- Data bytes are optional. Data bytes are present for data transfer instructions such as READ or PROGRAM.

The instruction code, the address/option and the data can be sent with Single-bit SPI, Dual SPI or Quad SPI protocols.

# SAM D5x/E5x Family Data Sheet

## QSPI - Quad Serial Peripheral Interface

**Figure 37-9. Instruction Frame**



### 37.6.8.2 Instruction Frame Sending

To send an instruction frame, the user must first configure the address to send by writing the field ADDR in the Instruction Address Register (INSTRADDR.ADDR). This step is required if the instruction frame includes an address and no data. When data is present, the address of the instruction is defined by the address of the data accesses in the QSPI memory space, and not by the INSTRADDR register.

If the instruction frame includes the instruction code and/or the option code, the user must configure the instruction code and/or the option code to send by writing the fields INST and OPTCODE bit fields in the Instruction Control Register (INSTRCTRL.OPTCODE, INSTRCTRL.INSTR).

Then, the user must write the Instruction Frame Register (INSTRFRAME) to configure the instruction frame depending on which instruction must be sent. If the instruction frame does not include data, writing in this register triggers the send of the instruction frame in the QSPI. If the instruction frame includes data, the send of the instruction frame is triggered by the first data access in the QSPI memory space.

The instruction frame is configured by the following bits and fields of INSTRFRAME:

- WIDTH field is used to configure which data lanes are used to send the instruction code, the address, the option code and to transfer the data. It is possible to use two unidirectional data lanes (MISO-MOSI Single-bit SPI), two bidirectional data lanes (DATA0 - DATA1 Dual SPI) or four bidirectional data lanes (DATA0 - DATA3).

**Table 37-3. WIDTH Encoding**

INSTRFRAME	Instruction	Address/Option	Data
0	Single-bit SPI	Single-bit SPI	Single-bit SPI
1	Single-bit SPI	Single-bit SPI	Dual SPI
2	Single-bit SPI	Single-bit SPI	Quad SPI
3	Single-bit SPI	Dual SPI	Dual SPI
4	Single-bit SPI	Quad SPI	Quad SPI
5	Dual SPI	Dual SPI	Dual SPI
6	Quad SPI	Quad SPI	Quad SPI
7	Reserved		

- INSTREN bit enables sending an instruction code.
- ADDREN bit enables sending of an address after the instruction code.
- OPTCODEEN bit enables sending of an option code after the address.
- DATAEN bit enables the transfer of data (READ or PROGRAM instruction).

# SAM D5x/E5x Family Data Sheet

## QSPI - Quad Serial Peripheral Interface

---

- OPTCODELEN field configures the option code length (0 -> 1-bit / 1 -> 2-bit / 2 -> 4-bit / 3 -> 8-bit). The value written in OPTCODELEN must be consistent with value written in the field WIDTH. For example: OPTCODELEN = 0 (1-bit option code) is not coherent with WIDTH = 6 (option code sent with QuadSPI protocol, thus the minimum length of the option code is 4-bit).
- ADDRLEN bit configures the address length (0 -> 24 bits / 1-> 32 bits)
- TFRTYPE field defines which type of data transfer must be performed.
- DUMMYLEN field configures the number of dummy cycles when reading data from the serial flash memory. Between the address/option and the data, with some instructions, dummy cycles are inserted by the serial flash memory.

If data transfer is enabled, the user can access the serial memory by reading or writing the QSPI memory space following these rules:

- Reading from the serial memory, but not memory data (for example reading the JEDEC-ID or the STATUS), requires TFRTYPE to be written to 0x0.
- Reading from the serial memory, and particularly memory data, requires TFRTYPE to be written to '1'.
- Writing to the serial memory, but not memory data (for example writing the configuration or STATUS), requires TFRTYPE to be written to 0x2.
- Writing to the serial memory, and particularly memory data, requires TFRTYPE to be written to 0x3.

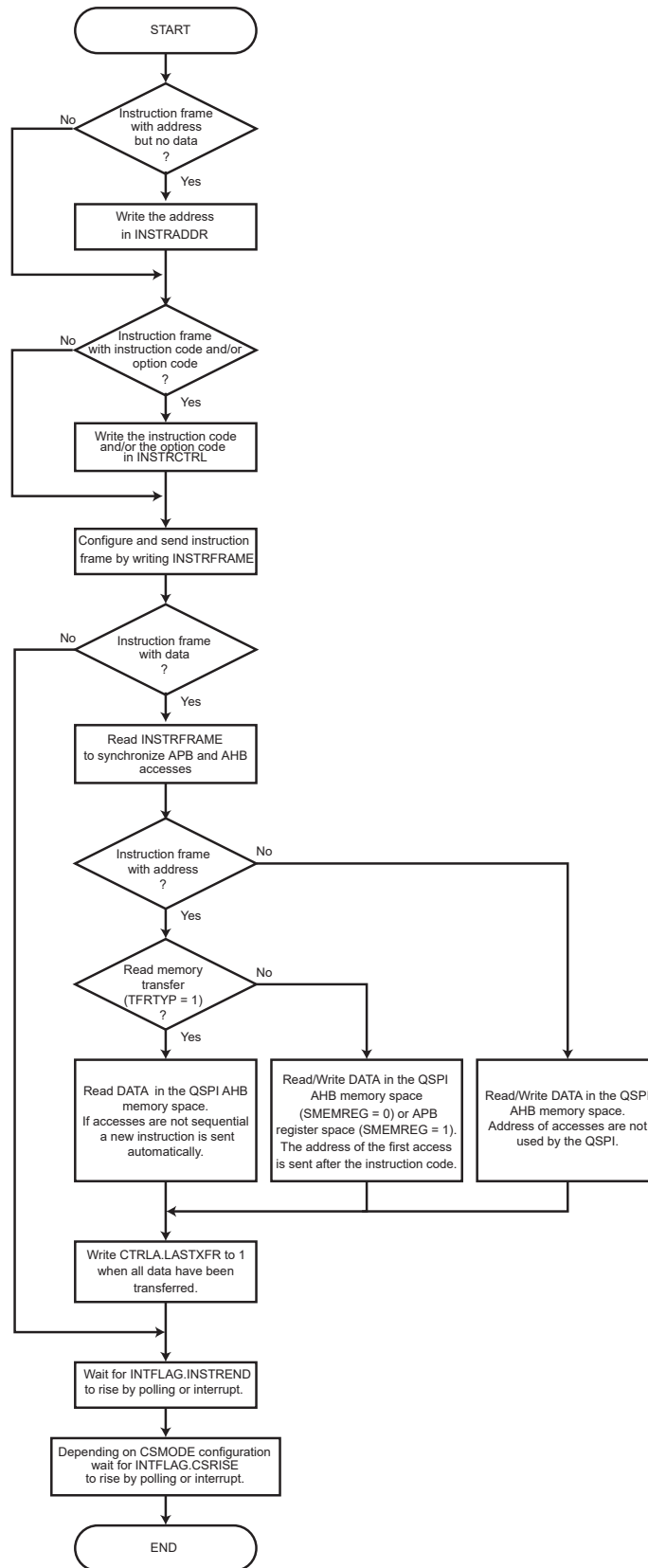
If TFRTYPE has a value other than 0x1 and CTRLB.SMEMREG=0, the address sent in the instruction frame is the address of the first system bus accesses. The addresses of the subsequent access actions are not used by the QSPI. At each system bus access, an SPI transfer is performed with the same size. For example, a half-word system bus access leads to a 16-bit SPI transfer, and a byte system bus access leads to an 8-bit SPI transfer.

If CTRLB.SMEMREG=1, accesses are made via the QSPI registers and the address sent in the instruction frame is the address defined in the INSTRADDR register. Each time the INSTRFRAME or TXDATA registers are written, an SPI transfer is performed with a byte size. Another byte is read each time RXDATA register is read or written each time TXDATA register is written. The SPI transfer ends by writing the LASTXFER bit in Control A register (CTRLA.LASTXFER).

If TFRTYPE=0x1, the address of the first instruction frame is the one of the first read access in the QSPI memory space. Each time the read accesses become non-sequential (addresses are not consecutive), a new instruction frame is sent with the last system bus access address. In this way, the system can read data at a random location in the serial memory. The size of the SPI transfers may differ from the size of the system bus read accesses.

When data transfer is not enabled, the end of the instruction frame is indicated when the INSTREND interrupt flag in the INTFLAG register is set. When data transfer is enabled, the user must indicate when data transfer is completed in the QSPI memory space by setting the bit LASTXFR in the CTRLA. The end of the instruction frame is indicated when the INSTREND interrupt flag in the INTFLAG register is set.

**Figure 37-10. Instruction Transmission Flow Diagram**



### 37.6.8.3 Read Memory Transfer

The user can access the data of the serial memory by sending an instruction with DATAEN=1 and TFRTP=0x1 in the Instruction Frame register (INSTRFRAME).

In this mode the QSPI is able to read data at random address into the serial flash memory, allowing the CPU to execute code directly from it (XIP execute-in-place).

In order to fetch data, the user must first configure the instruction frame by writing the INSTRFRAME. Then data can be read at any address in the QSPI address space mapping. The address of the system bus read accesses match the address of the data inside the serial Flash memory.

When Fetch Mode is enabled, several instruction frames can be sent before writing the bit LASTXFR in the CTRLA. Each time the system bus read accesses become non-sequential (addresses are not consecutive), a new instruction frame is sent with the corresponding address.

### 37.6.8.4 Continuous Read Mode

The QSPI is compatible with Continuous Read Mode (CRM) which is implemented in some Serial Flash memories.

The CRM allows to reduce the instruction overhead by excluding the instruction code from the instruction frame. When CRM is activated in a Serial Flash memory (by a specific option code), the instruction code is stored in the memory. For the next instruction frames, the instruction code is not required, as the memory uses the stored one.

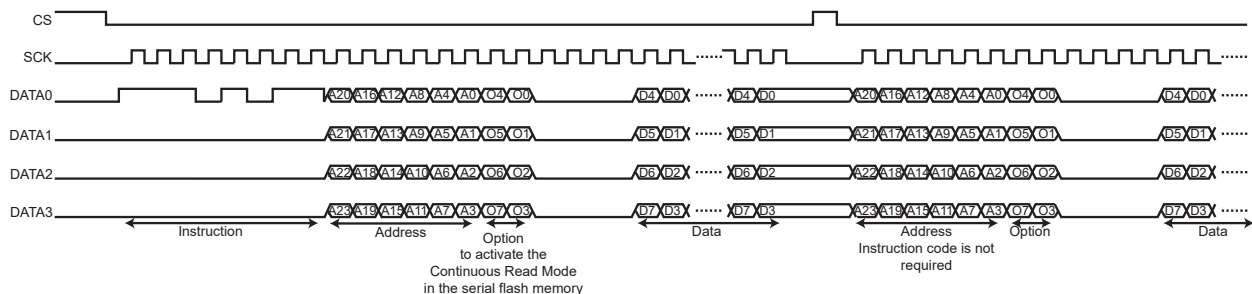
In the QSPI, CRM is used when reading data from the memory (INSTRFRAME.TFRTP=0x1). The addresses of the system bus read accesses are often non-sequential, this leads to many instruction frames with always the same instruction code. By disabling the sending of the instruction code, the CRM reduces the access time of the data.

To be functional, this mode must be enabled in both the QSPI and the Serial Flash memory. The CRM is enabled in the QSPI by setting the CRM bit in the INSTRFRAME register (INSTRFRAME.CRMODE=1, INSTRFRAME.TFRTP must be 0x1). The CRM is enabled in the Serial Flash memory by sending a specific option code.



If CRM is not supported by the Serial Flash memory or disabled, the CRMODE bit must not be set. Otherwise, data read out the Serial Flash memory is not valid.

**Figure 37-11. Continuous Read Mode**



### 37.6.8.5 Instruction Frame Transmission Examples

All waveforms in the following examples describe SPI transfers in SPI Clock mode 0 (BAUD.CPOL=0 and BAUD.CPHA=0). All system bus accesses described below refer to the system bus address phase. System bus wait cycles and system bus data phases are not shown.



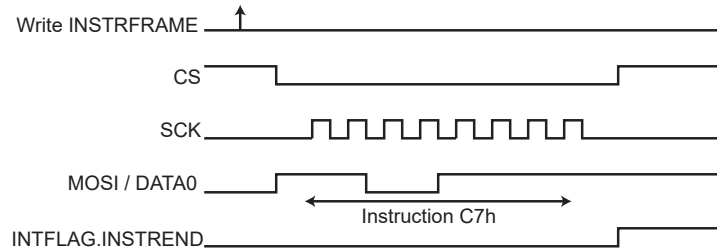
### Example 37-1. Example 1

Instruction in Single-bit SPI, without address, without option, without data.

Command: CHIP ERASE (C7h).

- Write 0x0000\_00C7 to INSTRCTRL register.
- Write 0x0000\_0010 to INSTRFRAME register.
- Wait for INTFLAG.INSTREND to rise.

**Figure 37-12. Instruction Transmission Waveform 1**



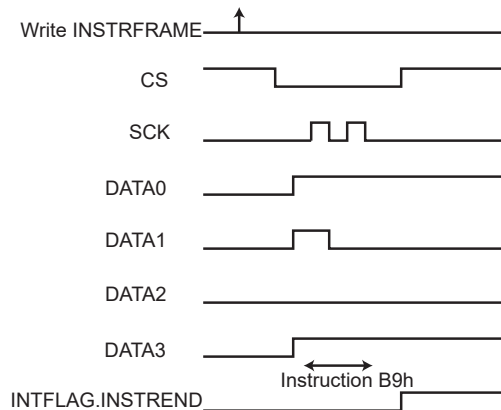
### Example 37-2. Example 2

Instruction in Quad SPI, without address, without option, without data.

Command: POWER DOWN (B9h)

- Write 0x0000\_00B9 to INSTRCTRL register.
- Write 0x0000\_0016 to INSTRFRAME register.
- Wait for INTFLAG.INSTREND to rise.

**Figure 37-13. Instruction Transmission Waveform 2**



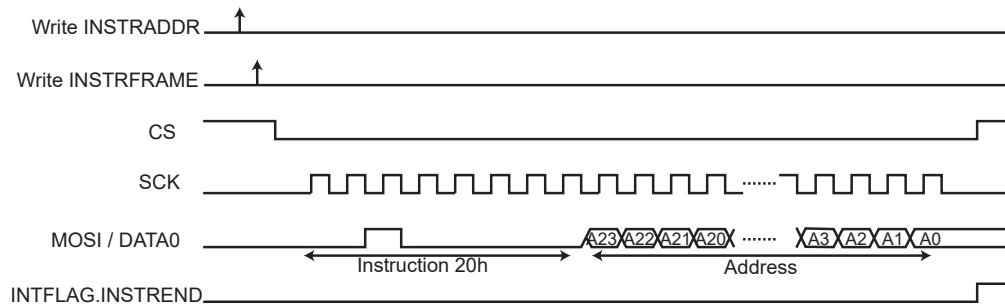
### Example 37-3. Example 3

Instruction in Single-bit SPI, with address in Single-bit SPI, without option, without data.

Command: BLOCK ERASE (20h)

- Write the address (of the block to erase) to QSPI\_AR.
- Write 0x0000\_0020 to INSTRCTRL register.
- Write 0x0000\_0030 to INSTRFRAME register.
- Wait for INTFLAG.INSTREND to rise.

**Figure 37-14. Instruction Transmission Waveform 3**



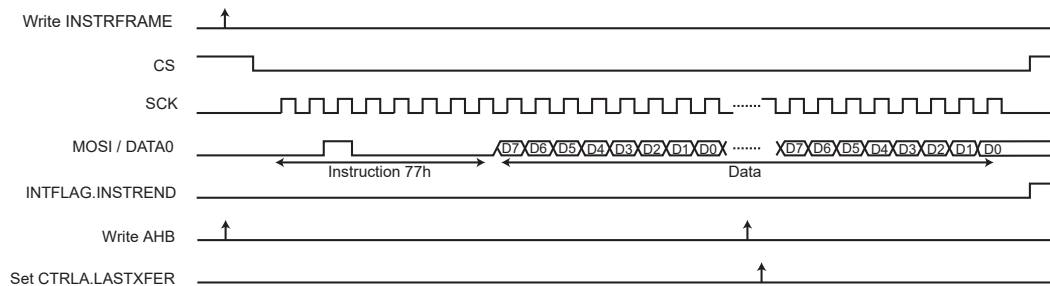
**Example 37-4. Example 4**

Instruction in Single-bit SPI, without address, without option, with data write in Single-bit SPI.

Command: SET BURST (77h)

- Write 0x0000\_0077 to INSTRCTRL register.
- Write 0x0000\_2090 to INSTRFRAME register.
- Read INSTRFRAME register (dummy read) to synchronize system bus accesses.
- Write data to the system bus memory space (0x0400\_0000–0x0500\_0000). The address of the system bus write accesses is not used.
- Write the LASTXFR bit in CTRLA register to '1'.
- Wait for INTFLAG.INSTREND to rise.

**Figure 37-15. Instruction Transmission Waveform 4**



**Example 37-5. Example 5**

Instruction in Single-bit SPI, with address in Dual SPI, without option, with data write in Dual SPI.

Command: BYTE/PAGE PROGRAM (02h)

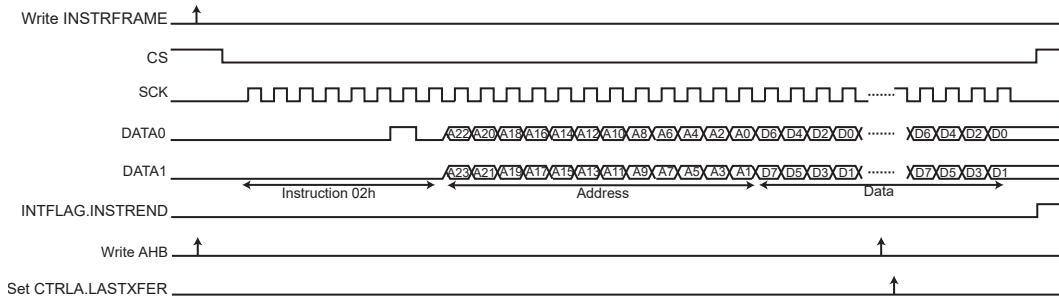
- Write 0x0000\_0002 to INSTRCTRL register.
- Write 0x0000\_30B3 to INSTRFRAME register.
- Read INSTRFRAME register (dummy read) to synchronize system bus accesses.
- Write data to the QSPI system bus memory space (0x040 00000–0x0500\_0000).  
The address of the first system bus write access is sent in the instruction frame.  
The address of the next system bus write accesses is not used.
- Write LASTXFR bit in CTRLA register to '1'.

# SAM D5x/E5x Family Data Sheet

## QSPI - Quad Serial Peripheral Interface

- Wait for INTFLAG.INSTREND to rise.

**Figure 37-16. Instruction Transmission Waveform 5**



**Example 37-6. Example 6**

Instruction in Single-bit SPI, with address in Single-bit SPI, without option, with data read in Quad SPI, with eight dummy cycles.

Command: QUAD\_OUTPUT READ ARRAY (6Bh)

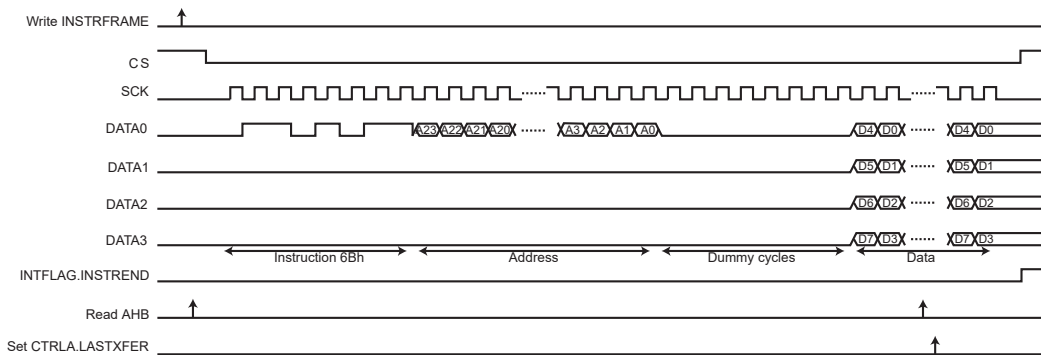
- Write 0x0000\_006B to INSTRCTRL register.
- Write 0x0008\_10B2 to INSTRFRAME register.
- Read QSPI\_IR (dummy read) to synchronize system bus accesses.
- Read data from the QSPI system bus memory space (0x040\_00000–0x0500\_0000).

The address of the first system bus read access is sent in the instruction frame.

The address of the next system bus read accesses is not used.

- Write the LASTXFR bit in CTRLA register to '1'.
- Wait for INTFLAG.INSTREND to rise.

**Figure 37-17. Instruction Transmission Waveform 6**



**Example 37-7. Example 7**

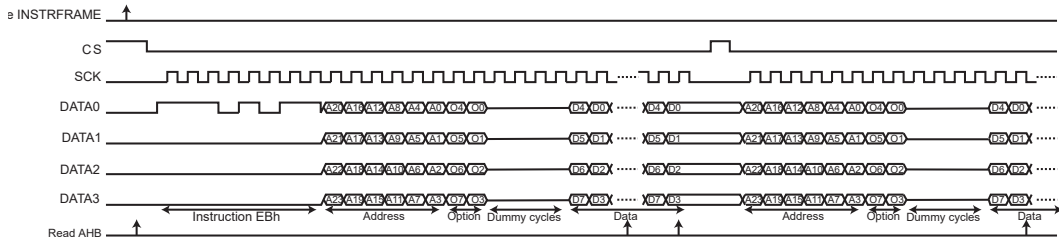
Instruction in Single-bit SPI, with address and option in Quad SPI, with data read from Quad SPI, with four dummy cycles, with fetch and continuous read.

Command: FAST READ QUAD I/O (EBh) - 8-BIT OPTION (0x30h)

- Write 0x0030\_00EB to INSTRCTRL register.
- Write 0x0004\_33F4 to INSTRFRAME register.
- Read INSTRFRAME register (dummy read) to synchronize system bus accesses.

- Read data from the QSPI system bus memory space (0x040 00000–0x0500\_0000).  
Fetch is enabled, the address of the system bus read accesses is always used.
- Write LASTXFR bit in CTRLA register to '1'.
- Wait for INTFLAG.INSTREND to rise.

**Figure 37-18. Instruction Transmission Waveform 7**



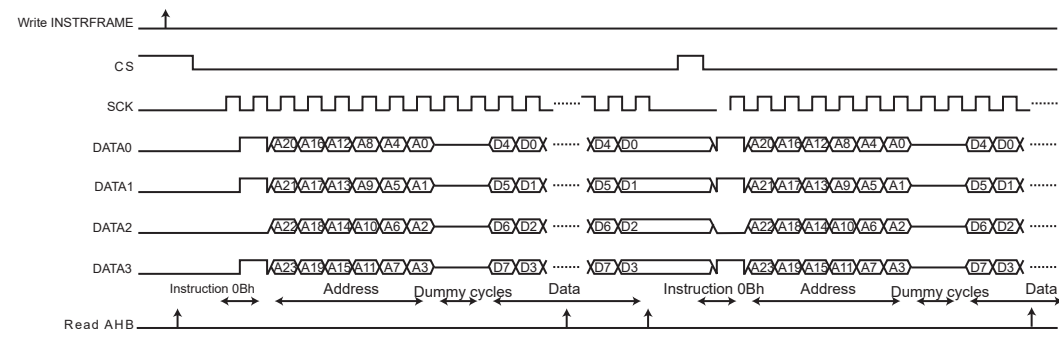
### Example 37-8. Example 8

Instruction in Quad SPI, with address in Quad SPI, without option, with data read from Quad SPI, with two dummy cycles, with fetch.

Command: HIGH-SPEED READ (0Bh)

- Write 0x0000\_000B to INSTRCTRL register.
- Write 0x0002\_20B6 to INSTRFRAME register.
- Read INSTRFRAME register (dummy read) to synchronize system bus accesses.
- Read data in the QSPI system bus memory space (0x040 00000–0x0500\_0000).  
Fetch is enabled, the address of the system bus read accesses is always used.
- Write LASTXFR bit in CTRLA register to '1'.
- Wait for INTFLAG.INSTREND to rise.

**Figure 37-19. Instruction Transmission Waveform 8**



### 37.6.9 Scrambling/Unscrambling Function

The scrambling/unscrambling function cannot be performed on devices other than memories. Data is scrambled when written to memory and unscrambled when data is read.

The external data lines can be scrambled in order to prevent intellectual property data located in off-chip memories from being easily recovered by analyzing data at the package pin level of either the microcontroller or the QSPI slave device (e.g. memory).

The scrambling/unscrambling function can be enabled by writing a '1' to the ENABLE bit in the Scrambling Control register (SCRAMBCTRL.ENABLE).

# SAM D5x/E5x Family Data Sheet

## QSPI - Quad Serial Peripheral Interface

---

The scrambling and unscrambling are performed on-the-fly without impacting the throughput.

The scrambling method depends on the user-configurable Scrambling User Key in the Scrambling Key register (SCRAMBKEY.KEY). This register is only accessible in write mode.

By default, the scrambling and unscrambling algorithm includes the scrambling user key, plus a device-dependent random value. This random value is not included when the Scrambling/Unscrambling Random Value Disable bit in the Scrambling Mode register (SCRAMBCTRL.RANDOMDIS) is written to '1'.

The random value is neither user configurable nor readable. If SCRAMBCTRL.RANDOMDIS=0, data scrambled by a given circuit cannot be unscrambled by a different circuit.

If SCRAMBCTRL.RANDOMDIS=1, the scrambling/unscrambling algorithm includes only the scrambling user key, making it possible to manage data by different circuits. Note that the same key must be used by the different circuits.

The scrambling user key must be securely stored in a reliable non-volatile memory in order to recover data from the off-chip memory. Any data scrambled with a given key cannot be recovered if the key is lost.

### 37.6.10 DMA Operation

The QSPI generates the following DMA requests:

- Data received (RX): The request is set when data is available in the RXDATA register, and cleared when RXDATA is read.
- Data transmit (TX): The request is set when the transmit buffer (TXDATA) is empty, and cleared when TXDATA is written.

**Note:** If DMA and RX memory modes are selected, a QSPI memory space read operation is required to force the first triggering.

If the CPU accesses the registers which are source of DMA request set/clear condition, the DMA request can be lost or the DMA transfer can be corrupted.

### 37.6.11 Interrupts

The QSPI has the following interrupt source:

- Interrupt Request (INTREQ): Indicates that at least one bit in the Interrupt Flag Status and Clear register (INTFLAG) is set to '1'.

Each interrupt source has an interrupt flag associated with it. The interrupt flag in the Interrupt Flag Status and Clear (INTFLAG) register is set when the interrupt condition occurs. Each interrupt can be individually enabled by writing a '1' to the corresponding bit in the Interrupt Enable Set (INTENSET) register, and disabled by writing a '1' to the corresponding bit in the Interrupt Enable Clear (INTENCLR) register. An interrupt request is generated when the interrupt flag is set and the corresponding interrupt is enabled. The interrupt request remains active until the interrupt flag is cleared, the interrupt is disabled, or the QSPI is reset. All interrupt requests from the peripheral are ORed together on system level to generate one combined interrupt request to the NVIC. The user must read the INTFLAG register to determine which interrupt condition is present.

Note that interrupts must be globally enabled for interrupt requests to be generated.

# SAM D5x/E5x Family Data Sheet

## QSPI - Quad Serial Peripheral Interface

### 37.7 Register Summary

Offset	Name	Bit Pos.								
0x00	CTRLA	7:0							ENABLE	SWRST
		15:8								
		23:16								
		31:24								LASTXFER
0x04	CTRLB	7:0			CSMODE[1:0]	SMEMREG	WDRBT	LOOPEN		MODE
		15:8						DATALEN[3:0]		
		23:16						DLYBCT[7:0]		
		31:24						DLYCS[7:0]		
0x08	BAUD	7:0							CPHA	CPOL
		15:8						BAUD[7:0]		
		23:16						DLYBS[7:0]		
		31:24								
0x0C	RXDATA	7:0								DATA[7:0]
		15:8								DATA[15:8]
		23:16								
		31:24								
0x10	TXDATA	7:0								DATA[7:0]
		15:8								DATA[15:8]
		23:16								
		31:24								
0x14	INTENCLR	7:0					ERROR	TXC	DRE	RXC
		15:8						INSTREND		CSRISRE
		23:16								
		31:24								
0x18	INTENSET	7:0					ERROR	TXC	DRE	RXC
		15:8						INSTREND		CSRISRE
		23:16								
		31:24								
0x1C	INTFLAG	7:0					ERROR	TXC	DRE	RXC
		15:8						INSTREND		CSRISRE
		23:16								
		31:24								
0x20	STATUS	7:0							ENABLE	
		15:8							CSSTATUS	
		23:16								
		31:24								
0x24 ... 0x2F	Reserved									
0x30	INSTRADDR	7:0								ADDR[7:0]
		15:8								ADDR[15:8]
		23:16								ADDR[23:16]
		31:24								ADDR[31:24]

# SAM D5x/E5x Family Data Sheet

## QSPI - Quad Serial Peripheral Interface

.....continued											
Offset	Name	Bit Pos.									
0x34	INSTRCTRL	7:0	INSTR[7:0]								
		15:8									
		23:16	OPTCODE[7:0]								
		31:24									
0x38	INSTRFRAME	7:0	DATAEN	OPTCODEEN	ADDREN	INSTREN		WIDTH[2:0]			
		15:8	DDREN	CRMODE	TFRTYPE[1:0]			ADDRLLEN	OPTCODELEN[1:0]		
		23:16				DUMMYLEN[4:0]					
		31:24									
0x3C ... 0x3F	Reserved										
0x40	SCRAMBCTRL	7:0						RANDOMDIS	ENABLE		
		15:8									
		23:16									
		31:24									
0x44	SCRAMBKEY	7:0	KEY[7:0]								
		15:8	KEY[15:8]								
		23:16	KEY[23:16]								
		31:24	KEY[31:24]								

### 37.8 Register Description

Registers can be 8, 16, or 32 bits wide. Atomic 8-, 16-, and 32-bit accesses are supported. In addition, the 8-bit quarters and 16-bit halves of a 32-bit register, and the 8-bit halves of a 16-bit register can be accessed directly.

Optional write protection by the Peripheral Access Controller (PAC) is denoted by the "PAC Write Protection" property in each individual register description.

Refer to the Peripheral Access Controller for more information.

Some registers are enable-protected, meaning they can only be written when the QSPI is disabled. Enable-protection is denoted by the Enable-Protected property in each individual register description.

# SAM D5x/E5x Family Data Sheet

## QSPI - Quad Serial Peripheral Interface

### 37.8.1 Control A

**Name:** CTRLA  
**Offset:** 0x00  
**Reset:** 0x00000000  
**Property:** -

Control A

	Bit	31	30	29	28	27	26	25	24
									LASTXFER
Access									W
Reset									0
	Bit	23	22	21	20	19	18	17	16
Access									
Reset									
	Bit	15	14	13	12	11	10	9	8
Access									
Reset									
	Bit	7	6	5	4	3	2	1	0
								ENABLE	SWRST
Access								R/W	W
Reset								0	0

**Bit 24 – LASTXFER** Last Transfer

0: No effect.

1: The chip select will be de-asserted after the character written in TD has been transferred.

**Bit 1 – ENABLE** Enable

Writing a '0' to this bit disables the QSPI.

Writing a '1' to this bit enables the QSPI to transfer and receive data.

As soon as ENABLE is reset, QSPI finishes its transfer.

All pins are set in input mode and no data is received or transmitted.

If a transfer is in progress, the transfer is finished before the QSPI is disable.

**Bit 0 – SWRST** Software Reset

Writing a '0' to this bit has no effect.

Writing a '1' to this bit resets the QSPI. A software-triggered hardware reset of the QSPI interface is performed.

DMAC channels are not affected by software reset.



# SAM D5x/E5x Family Data Sheet

## QSPI - Quad Serial Peripheral Interface

### 37.8.2 Control B

**Name:** CTRLB  
**Offset:** 0x04  
**Reset:** 0x00000000  
**Property:** PAC Write-Protection

#### Control B

Bit	31	30	29	28	27	26	25	24
DLYCS[7:0]								
Access	R/W	R/W	R/W	R/W	R/W	R/W	R/W	R/W
Reset	0	0	0	0	0	0	0	0
Bit	23	22	21	20	19	18	17	16
DLYBCT[7:0]								
Access	R/W	R/W	R/W	R/W	R/W	R/W	R/W	R/W
Reset	0	0	0	0	0	0	0	0
Bit	15	14	13	12	11	10	9	8
DATALEN[3:0]								
Access					R/W	R/W	R/W	R/W
Reset					0	0	0	0
Bit	7	6	5	4	3	2	1	0
CSMODE[1:0]    SMEMREG    WDRBT    LOOPEN    MODE								
Access			R/W	R/W	R/W	R/W	R/W	R/W
Reset			0	0	0	0	0	0

#### Bits 31:24 – DLYCS[7:0] Minimum Inactive CS Delay

This bit field defines the minimum delay between the inactivation and the activation of CS. The DLYCS time guarantees the slave minimum deselect time.

If DLYCS is 0x00, one CLK\_QSPI\_AHB period will be inserted by default.

Otherwise, the following equation determines the delay:

#### Bits 23:16 – DLYBCT[7:0] Delay Between Consecutive Transfers

This field defines the delay between two consecutive transfers with the same peripheral without removing the chip select. The delay is always inserted after each transfer and before removing the chip select if needed.

When DLYBCT=0x00, no delay between consecutive transfers is inserted and the clock keeps its duty cycle over the character transfers. In Serial Memory mode (MODE=1), DLYBCT is ignored and no delay is inserted. Otherwise, the following equation determines the delay:

#### Bits 11:8 – DATALEN[3:0] Data Length

The DATALEN field determines the number of data bits transferred. Reserved values should not be used.

Value	Name	Description
0x0	8BITS	8-bits transfer
0x1	9BITS	9-bits transfer
0x2	10BITS	10-bits transfer
0x3	11BITS	11-bits transfer

# SAM D5x/E5x Family Data Sheet

## QSPI - Quad Serial Peripheral Interface

Value	Name	Description
0x4	12BITS	12-bits transfer
0x5	13BITS	13-bits transfer
0x6	14BITS	14-bits transfer
0x7	15BITS	15-bits transfer
0x8	16BITS	16-bits transfer
0x9-0xF		Reserved

### Bits 5:4 – CSMODE[1:0] Chip Select Mode

The CSMODE field determines how the chip select is de-asserted.

Value	Name	Description
0x0	NORELOAD	The chip select is de-asserted if TD has not been reloaded before the end of the current transfer.
0x1	LASTXFER	The chip select is de-asserted when the bit LASTXFER is written at 1 and the character written in TD has been transferred.
0x2	SYSTEMATICALLY	The chip select is de-asserted systematically after each transfer.
0x3		Reserved

### Bit 3 – SMEMREG Serial Memory Register Mode

Value	Description
0	Serial memory registers are written via AHB access.
1	Serial memory registers are written via APB access. Reset the QSPI.

### Bit 2 – WDRBT Wait Data Read Before Transfer

This bit determines the Wait Data Read Before Transfer option.

### Bit 1 – LOOPEN Local Loopback Enable

This bit defines if the Local Loopback is enabled or disabled.

LOOPEN controls the local loopback on the data serializer for testing in SPI Mode only. (MISO is internally connected on MOSI).

Value	Description
0	Local Loopback is disabled.
1	Local Loopback is enabled.

### Bit 0 – MODE Serial Memory Mode

This bit defines if the QSPI is in SPI Mode or Serial Memory Mode.

Value	Name	Description
0	SPI	SPI operating mode
1	MEMORY	Serial Memory operating mode

# SAM D5x/E5x Family Data Sheet

## QSPI - Quad Serial Peripheral Interface

### 37.8.3 Baud Rate

**Name:** BAUD  
**Offset:** 0x08  
**Reset:** 0x00000000  
**Property:** PAC Write-Protection

	31	30	29	28	27	26	25	24
Access								
Reset								
	23	22	21	20	19	18	17	16
	DLYBS[7:0]							
Access	R/W	R/W	R/W	R/W	R/W	R/W	R/W	R/W
Reset	0	0	0	0	0	0	0	0
	15	14	13	12	11	10	9	8
	BAUD[7:0]							
Access	R/W	R/W	R/W	R/W	R/W	R/W	R/W	R/W
Reset	0	0	0	0	0	0	0	0
	7	6	5	4	3	2	1	0
							CPHA	CPOL
Access							R/W	R/W
Reset							0	0

#### Bits 23:16 – DLYBS[7:0] Delay Before SCK

This field defines the delay from CS valid to the first valid SCK transition.

When DLYBS equals zero, the CS valid to SCK transition is 1/2 the SCK clock period.

Otherwise, the following equation determines the delay:

#### Equation 37-1. Delay Before SCK

$$\text{Delay Before SCK} = \frac{DLYBS}{MCK}$$

#### Bits 15:8 – BAUD[7:0] Serial Clock Baud Rate

The QSPI uses a modulus counter to derive the SCK baud rate from the module clock CLK\_QSPI\_AHB.

The Baud rate is selected by writing a value from 0 to 255 in the BAUD field. The following equation determines the SCK baud rate:

#### Equation 37-2. SCK Baud Rate

$$\text{SCK Baud Rate} = \frac{MCK}{(BAUD + 1)}$$

#### Bit 1 – CPHA Clock Phase

CPHA determines which edge of SCK causes data to change and which edge causes data to be captured. CPHA is used with CPOL to produce the required clock/data relationship between master and slave devices.

# SAM D5x/E5x Family Data Sheet

## QSPI - Quad Serial Peripheral Interface

---

---

Value	Description
0	Data is captured on the leading edge of SCK and changed on the following edge of SCK.
1	Data is changed on the leading edge of SCK and captured on the following edge of SCK.

### Bit 0 – CPOL Clock Polarity

CPOL is used to determine the inactive state value of the serial clock (SCK). It is used with CPHA to produce the required clock/data relationship between master and slave devices.

Value	Description
0	The inactive state value of SCK is logic level zero.
0	The inactive state value of SCK is logic level 'one'.

# SAM D5x/E5x Family Data Sheet

## QSPI - Quad Serial Peripheral Interface

### 37.8.4 Receive Data

**Name:** RXDATA  
**Offset:** 0x0C  
**Reset:** 0x00000000  
**Property:** -

	Bit	31	30	29	28	27	26	25	24
Access									
Reset									
	Bit	23	22	21	20	19	18	17	16
Access									
Reset									
	Bit	15	14	13	12	11	10	9	8
Access		R	R	R	R	R	R	R	R
Reset		0	0	0	0	0	0	0	0
	Bit	7	6	5	4	3	2	1	0
Access		R	R	R	R	R	R	R	R
Reset		0	0	0	0	0	0	0	0

**Bits 15:0 – DATA[15:0] Receive Data**

Data received by the QSPI is stored in this register right-justified. Unused bits read zero.

# SAM D5x/E5x Family Data Sheet

## QSPI - Quad Serial Peripheral Interface

### 37.8.5 Transmit Data

**Name:** TXDATA  
**Offset:** 0x10  
**Reset:** 0x00000000  
**Property:** -

	Bit	31	30	29	28	27	26	25	24
Access									
Reset									
	Bit	23	22	21	20	19	18	17	16
Access									
Reset									
	Bit	15	14	13	12	11	10	9	8
		DATA[15:8]							
Access		W	W	W	W	W	W	W	W
Reset		0	0	0	0	0	0	0	0
	Bit	7	6	5	4	3	2	1	0
		DATA[7:0]							
Access		W	W	W	W	W	W	W	W
Reset		0	0	0	0	0	0	0	0

**Bits 15:0 – DATA[15:0] Transmit Data**

Data to be transmitted by the QSPI is stored in this register. Information to be transmitted must be written to the transmit data register in a right-justified format.

# SAM D5x/E5x Family Data Sheet

## QSPI - Quad Serial Peripheral Interface

### 37.8.6 Interrupt Enable Clear

**Name:** INTENCLR  
**Offset:** 0x14  
**Reset:** 0x00000000  
**Property:** PAC Write-Protection

	Bit	31	30	29	28	27	26	25	24		
		[Bit Field Diagram: 8 bits, all reserved]									
Access											
Reset											
	Bit	23	22	21	20	19	18	17	16		
		[Bit Field Diagram: 8 bits, all reserved]									
Access											
Reset											
	Bit	15	14	13	12	11	10	9	8		
		[Bit Field Diagram: 6 bits, all reserved]						INSTREND	[Bit Field Diagram: 2 bits, all reserved]		CSRISE
Access								R/W			R/W
Reset								0			0
	Bit	7	6	5	4	3	2	1	0		
		[Bit Field Diagram: 4 bits, all reserved]				ERROR	TXC	DRE	[Bit Field Diagram: 2 bits, all reserved]		
Access						R/W	R/W	R/W			
Reset						0	0	0			

**Bit 10 – INSTREND** Instruction End Interrupt Disable  
 Writing a '0' to this bit has no effect.  
 Writing a '1' will clear the corresponding interrupt request.

Value	Description
0	The INSTREND interrupt is disabled.
1	The INSTREND interrupt is enabled.

**Bit 8 – CSRISE** Chip Select Rise Interrupt Disable  
 Writing a '0' to this bit has no effect.  
 Writing a '1' will clear the corresponding interrupt request.

Value	Description
0	The CSRISE interrupt is disabled.
1	The CSRISE interrupt is enabled.

**Bit 3 – ERROR** Overrun Error Interrupt Disable  
 Writing a '0' to this bit has no effect.  
 Writing a '1' will clear the corresponding interrupt request.

Value	Description
0	The ERROR interrupt is disabled.
1	The ERROR interrupt is enabled.

# SAM D5x/E5x Family Data Sheet

## QSPI - Quad Serial Peripheral Interface

---

**Bit 2 – TXC** Transmission Complete Interrupt Disable

Writing a '0' to this bit has no effect.

Writing a '1' will clear the corresponding interrupt request.

Value	Description
0	The TXC interrupt is disabled.
1	The TXC interrupt is enabled.

**Bit 1 – DRE** Transmit Data Register Empty Interrupt Disable

Writing a '0' to this bit has no effect.

Writing a '1' will clear the corresponding interrupt request.

Value	Description
0	The DRE interrupt is disabled.
1	The DRE interrupt is enabled.

**Bit 0 – RXC** Receive Data Register Full Interrupt Disable

Writing a '0' to this bit has no effect.

Writing a '1' will clear the corresponding interrupt request.

Value	Description
0	The RXC interrupt is disabled.
1	The RXC interrupt is enabled.



# SAM D5x/E5x Family Data Sheet

## QSPI - Quad Serial Peripheral Interface

### 37.8.7 Interrupt Enable Set

**Name:** INTENSET  
**Offset:** 0x18  
**Reset:** 0x00000000  
**Property:** PAC Write-Protection

	31	30	29	28	27	26	25	24	
Access									
Reset									
	23	22	21	20	19	18	17	16	
Access									
Reset									
	15	14	13	12	11	10	9	8	
						INSTREND			CSRISE
Access						R/W			R/W
Reset						0			0
	7	6	5	4	3	2	1	0	
					ERROR	TXC	DRE	RXC	
Access					R/W	R/W	R/W	R/W	
Reset					0	0	0	0	

**Bit 10 – INSTREND** Instruction End Interrupt Enable  
 Writing a '0' to this bit has no effect.  
 Writing a '1' will set the corresponding interrupt request.

Value	Description
0	The INSTREND interrupt is disabled.
1	The INSTREND interrupt is enabled.

**Bit 8 – CSRISE** Chip Select Rise Interrupt Enable  
 Writing a '0' to this bit has no effect.  
 Writing a '1' will set the corresponding interrupt request.

Value	Description
0	The CSRISE interrupt is disabled.
1	The CSRISE interrupt is enabled.

**Bit 3 – ERROR** Overrun Error Interrupt Enable  
 Writing a '0' to this bit has no effect.  
 Writing a '1' will set the corresponding interrupt request.

Value	Description
0	The ERROR interrupt is disabled.
1	The ERROR interrupt is enabled.

# SAM D5x/E5x Family Data Sheet

## QSPI - Quad Serial Peripheral Interface

---

---

**Bit 2 – TXC** Transmission Complete Interrupt Enable

Writing a '0' to this bit has no effect.

Writing a '1' will set the corresponding interrupt request.

Value	Description
0	The TXC interrupt is disabled.
1	The TXC interrupt is enabled.

**Bit 1 – DRE** Transmit Data Register Empty Interrupt Enable

Writing a '0' to this bit has no effect.

Writing a '1' will set the corresponding interrupt request.

Value	Description
0	The DRE interrupt is disabled.
1	The DRE interrupt is enabled.

**Bit 0 – RXC** Receive Data Register Full Interrupt Enable

Writing a '0' to this bit has no effect.

Writing a '1' will set the corresponding interrupt request.

Value	Description
0	The RXC interrupt is disabled.
1	The RXC interrupt is enabled.

# SAM D5x/E5x Family Data Sheet

## QSPI - Quad Serial Peripheral Interface

### 37.8.8 Interrupt Flag Status and Clear

**Name:** INTFLAG  
**Offset:** 0x1C  
**Reset:** 0x00000000  
**Property:** -

Bit	31	30	29	28	27	26	25	24	
Access									
Reset									
Bit	23	22	21	20	19	18	17	16	
Access									
Reset									
Bit	15	14	13	12	11	10	9	8	
						INSTREND			CSRISE
Access						R/W			R/W
Reset						0			0
Bit	7	6	5	4	3	2	1	0	
					ERROR	TXC	DRE	RXC	
Access					R/W	R/W	R/W	R/W	
Reset					0	0	0	0	

**Bit 10 – INSTREND** Instruction End  
 This bit is set when an Instruction End has been detected.  
 Writing a '0' to this bit has no effect.  
 Writing a '1' to this bit will clear the flag.

**Bit 8 – CSRISE** Chip Select Rise  
 The bit is set when a Chip Select Rise has been detected.  
 Writing a '0' to this bit has no effect.  
 Writing a '1' to this bit will clear the flag.

**Bit 3 – ERROR** Overrun Error  
 This bit is set when an ERROR has occurred.  
 An ERROR occurs when RXDATA is loaded at least twice from the serializer.  
 Writing a '0' to this bit has no effect.  
 Writing a '1' to this bit will clear the flag.

**Bit 2 – TXC** Transmission Complete  
 0: As soon as data is written in TXDATA.  
 1: TXDATA and internal shifter are empty. If a transfer delay has been defined, TXC is set after the completion of such delay.

# SAM D5x/E5x Family Data Sheet

## QSPI - Quad Serial Peripheral Interface

---

### **Bit 1 – DRE** Transmit Data Register Empty

0: Data has been written to TXDATA and not yet transferred to the serializer.

1: The last data written in the TXDATA has been transferred to the serializer.

This bit is '0' when the QSPI is disabled or at reset.

The bit is set as soon as ENABLE bit is set.

### **Bit 0 – RXC** Receive Data Register Full

0: No data has been received since the last read of RXDATA.

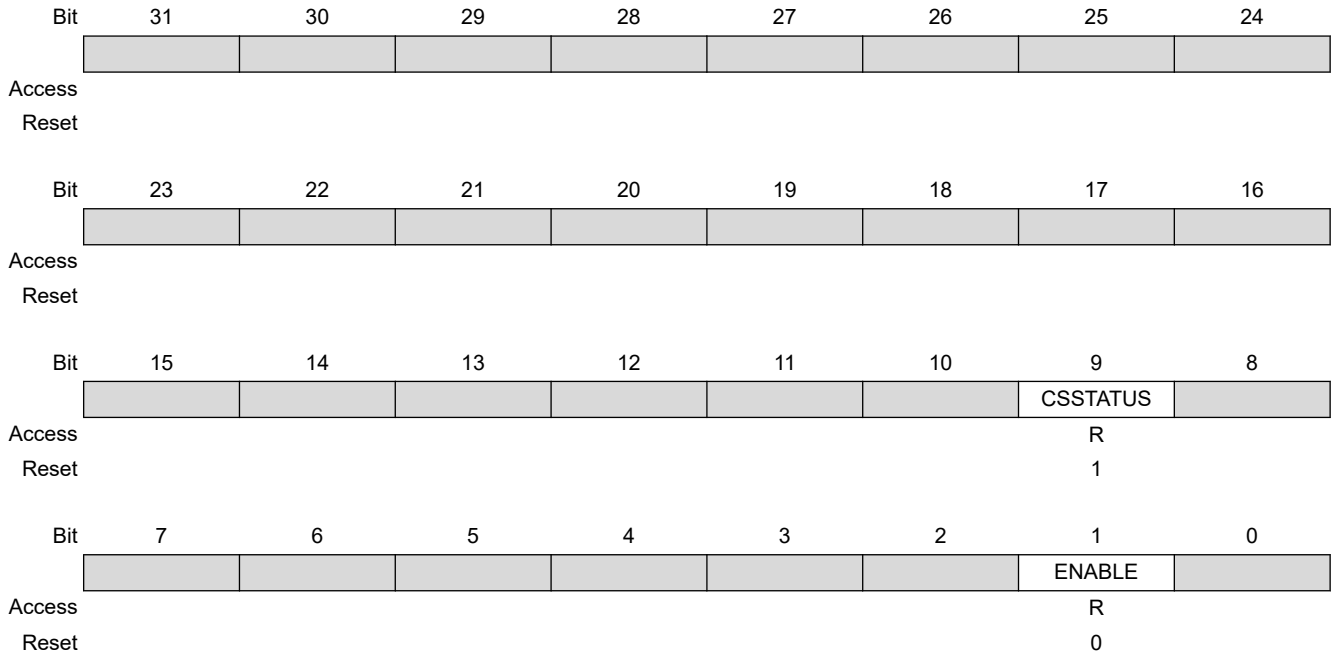
1: Data has been received and the received data has been transferred from the serializer to RXDATA since the last read of RXDATA.

# SAM D5x/E5x Family Data Sheet

## QSPI - Quad Serial Peripheral Interface

### 37.8.9 Status

**Name:** STATUS  
**Offset:** 0x20  
**Reset:** 0x00000200  
**Property:** -



#### Bit 9 – CSSTATUS Chip Select

Value	Description
0	Chip Select is asserted.
1	Chip Select is not asserted.

#### Bit 1 – ENABLE Enable

Value	Description
0	QSPI is disabled.
1	QSPI is enabled.

# SAM D5x/E5x Family Data Sheet

## QSPI - Quad Serial Peripheral Interface

### 37.8.10 Instruction Address

**Name:** INSTRADDR  
**Offset:** 0x30  
**Reset:** 0x00000000  
**Property:** -

	Bit	31	30	29	28	27	26	25	24
		ADDR[31:24]							
Access		R/W	R/W	R/W	R/W	R/W	R/W	R/W	R/W
Reset		0	0	0	0	0	0	0	0
	Bit	23	22	21	20	19	18	17	16
		ADDR[23:16]							
Access		R/W	R/W	R/W	R/W	R/W	R/W	R/W	R/W
Reset		0	0	0	0	0	0	0	0
	Bit	15	14	13	12	11	10	9	8
		ADDR[15:8]							
Access		R/W	R/W	R/W	R/W	R/W	R/W	R/W	R/W
Reset		0	0	0	0	0	0	0	0
	Bit	7	6	5	4	3	2	1	0
		ADDR[7:0]							
Access		R/W	R/W	R/W	R/W	R/W	R/W	R/W	R/W
Reset		0	0	0	0	0	0	0	0

**Bits 31:0 – ADDR[31:0] Instruction Address**

Address to send to the serial flash memory in the instruction frame.

# SAM D5x/E5x Family Data Sheet

## QSPI - Quad Serial Peripheral Interface

### 37.8.11 Instruction Code

**Name:** INSTRCTRL  
**Offset:** 0x34  
**Reset:** 0x00000000  
**Property:** -

Bit	31	30	29	28	27	26	25	24
Access								
Reset								
Bit	23	22	21	20	19	18	17	16
	OPTCODE[7:0]							
Access	R/W	R/W	R/W	R/W	R/W	R/W	R/W	R/W
Reset	0	0	0	0	0	0	0	0
Bit	15	14	13	12	11	10	9	8
Access								
Reset								
Bit	7	6	5	4	3	2	1	0
	INSTR[7:0]							
Access	R/W	R/W	R/W	R/W	R/W	R/W	R/W	R/W
Reset	0	0	0	0	0	0	0	0

**Bits 23:16 – OPTCODE[7:0]** Option Code

These bits define the option code to send to the serial flash memory.

**Bits 7:0 – INSTR[7:0]** Instruction Code

Instruction code to send to the serial flash memory.

# SAM D5x/E5x Family Data Sheet

## QSPI - Quad Serial Peripheral Interface

### 37.8.12 Instruction Frame

**Name:** INSTRFRAME  
**Offset:** 0x38  
**Reset:** 0x00000000  
**Property:** -

Bit	31	30	29	28	27	26	25	24	
Access									
Reset									
Bit	23	22	21	20	19	18	17	16	
				DUMMYLEN[4:0]					
Access				R/W	R/W	R/W	R/W	R/W	
Reset				0	0	0	0	0	
Bit	15	14	13	12	11	10	9	8	
	DDREN	CRMODE	TFRTYPE[1:0]			ADDRLEN	OPTCODELEN[1:0]		
Access	R/W	R/W	R/W	R/W		R/W	R/W	R/W	
Reset	0	0	0	0		0	0	0	
Bit	7	6	5	4	3	2	1	0	
	DATAEN	OPTCODEEN	ADDREN	INSTREN		WIDTH[2:0]			
Access	R/W	R/W	R/W	R/W		R/W	R/W	R/W	
Reset	0	0	0	0		0	0	0	

#### Bits 20:16 – DUMMYLEN[4:0] Dummy Cycles Length

The DUMMYLEN field defines the number of dummy cycles required by the serial Flash memory before data transfer.

#### Bit 15 – DDREN Double Data Rate Enable

Value	Description
0	Double Data Rate operating mode is disabled.
1	Double Data Rate operating mode is enabled.

#### Bit 14 – CRMODE Continuous Read Mode

This bit defines if the Continuous Read Mode is enabled or disabled.

Value	Description
0	Continuous Read Mode is disabled.
1	Continuous Read Mode is enabled.

#### Bits 13:12 – TFRTYPE[1:0] Data Transfer Type

These bits define the data type transfer.

Value	Name	Description
0x0	READ	Read transfer from the serial memory. Scrambling is not performed. Read at random location (fetch) in the serial flash memory is not possible.



# SAM D5x/E5x Family Data Sheet

## QSPI - Quad Serial Peripheral Interface

Value	Name	Description
0x1	READMEMORY	Read data transfer from the serial memory.If enabled, scrambling is performed.Read at random location (fetch) in the serial flash memory is possible.
0x2	WRITE	Write transfer into the serial memory.Scrambling is not performed.
0x3	WRITEMEMORY	Write data transfer into the serial memory. If enabled, scrambling is performed.

### Bit 10 – ADDRLEN Address Length

The ADDRLEN bit determines the length of the address.

Value	Name	Description
0x0	24BITS	24-bits address length
0x1	32BITS	32-bits address length

### Bits 9:8 – OPTCODELEN[1:0] Option Code Length

The OPTCODELEN field determines the length of the option code. The value written in OPTCODELEN must be coherent with value written in the field WIDTH. For example: OPTCODELEN=0 (1-bit option code) is not coherent with WIDTH=6 (option code sent with QuadSPI protocol, thus the minimum length of the option code is 4-bit).

Value	Name	Description
0x0	1BIT	1-bit length option code
0x1	2BITS	2-bits length option code
0x2	4BITS	4-bits length option code
0x3	8BITS	8-bits length option code

### Bit 7 – DATAEN Data Enable

Value	Description
0	No data is sent/received to/from the serial flash memory.
1	Data is sent/received to/from the serial flash memory.

### Bit 6 – OPTCODEEN Option Enable

Value	Description
0	The option is not sent to the serial flash memory
1	The option is sent to the serial flash memory.

### Bit 5 – ADDREN Address Enable

Value	Description
0	The transfer address is not sent to the serial flash memory.
1	The transfer address is sent to the serial flash memory.

### Bit 4 – INSTREN Instruction Enable

Value	Description
0	The instruction is not sent to the serial flash memory.
1	The instruction is sent to the serial flash memory.

### Bits 2:0 – WIDTH[2:0] Instruction Code, Address, Option Code and Data Width

This field defines the width of the instruction code, the address, the option and the data.

# SAM D5x/E5x Family Data Sheet

## QSPI - Quad Serial Peripheral Interface

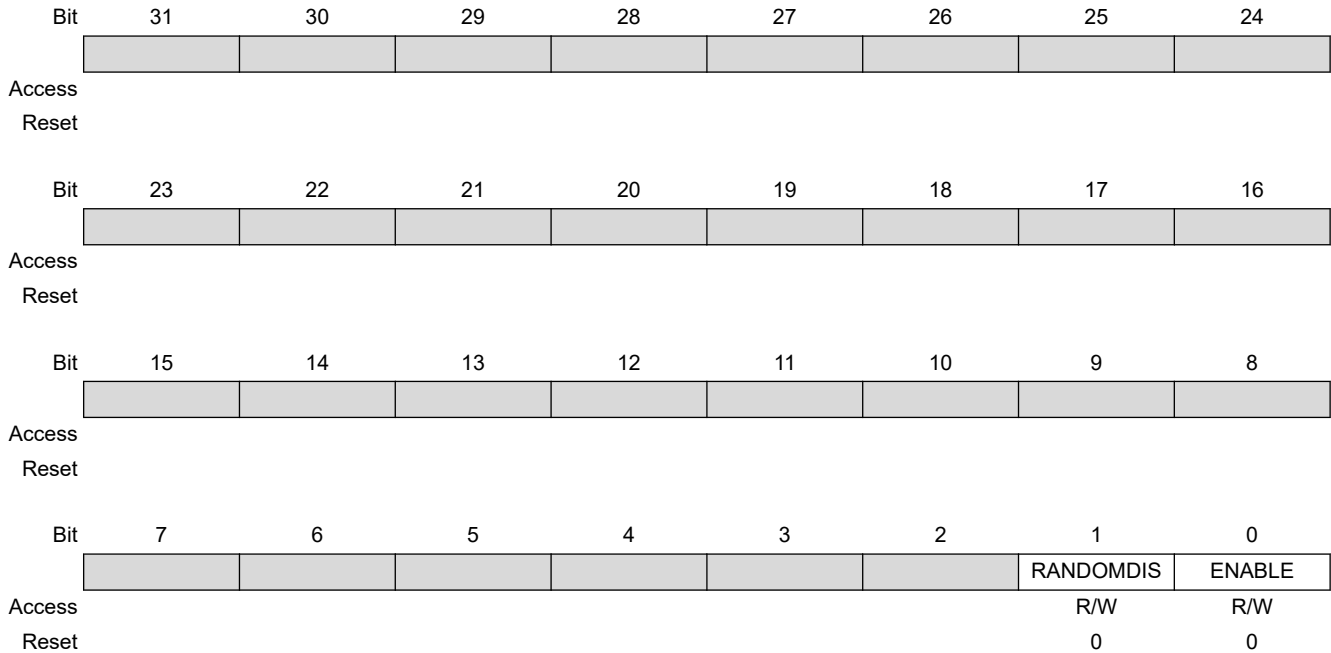
Value	Name	Description
0x0	SINGLE_BIT_SPI	Instruction: Single-bit SPI / Address-Option: Single-bit SPI / Data: Single-bit SPI
0x1	DUAL_OUTPUT	Instruction: Single-bit SPI / Address-Option: Single-bit SPI / Data: Dual SPI
0x2	QUAD_OUTPUT	Instruction: Single-bit SPI / Address-Option: Single-bit SPI / Data: Quad SPI
0x3	DUAL_IO	Instruction: Single-bit SPI / Address-Option: Dual SPI / Data: Dual SPI
0x4	QUAD_IO	Instruction: Single-bit SPI / Address-Option: Quad SPI / Data: Quad SPI
0x5	DUAL_CMD	Instruction: Dual SPI / Address-Option: Dual SPI / Data: Dual SPI
0x6	QUAD_CMD	Instruction: Quad SPI / Address-Option: Quad SPI / Data: Quad SPI
0x7		Reserved

# SAM D5x/E5x Family Data Sheet

## QSPI - Quad Serial Peripheral Interface

### 37.8.13 Scrambling Mode

**Name:** SCRAMBCTRL  
**Offset:** 0x40  
**Reset:** 0x00000000  
**Property:** PAC Write-Protection



**Bit 1 – RANDOMDIS** Scrambling/Unscrambling Random Value Disable

Value	Description
0	The scrambling/unscrambling algorithm includes the scrambling user key plus a random value that may differ from chip to chip.
1	The scrambling/unscrambling algorithm includes only the scrambling user key.

**Bit 0 – ENABLE** Scrambling/Unscrambling Enable

This bit defines if the scrambling/unscrambling is enabled or disabled.

Value	Description
0	Scrambling/unscrambling is disabled.
1	Scrambling/unscrambling is enabled.

# SAM D5x/E5x Family Data Sheet

## QSPI - Quad Serial Peripheral Interface

### 37.8.14 Scrambling Key

**Name:** SCRAMBKEY  
**Offset:** 0x44  
**Reset:** 0x00000000  
**Property:** PAC Write-Protection

	31	30	29	28	27	26	25	24
	KEY[31:24]							
Access	W	W	W	W	W	W	W	W
Reset	0	0	0	0	0	0	0	0
	23	22	21	20	19	18	17	16
	KEY[23:16]							
Access	W	W	W	W	W	W	W	W
Reset	0	0	0	0	0	0	0	0
	15	14	13	12	11	10	9	8
	KEY[15:8]							
Access	W	W	W	W	W	W	W	W
Reset	0	0	0	0	0	0	0	0
	7	6	5	4	3	2	1	0
	KEY[7:0]							
Access	W	W	W	W	W	W	W	W
Reset	0	0	0	0	0	0	0	0

**Bits 31:0 – KEY[31:0]** Scrambling User Key  
 This field defines the user key value.

## 38. USB – Universal Serial Bus

### 38.1 Overview

The Universal Serial Bus interface (USB) module complies with the Universal Serial Bus (USB) 2.1 specification supporting both device and embedded host modes.

The USB device mode supports 8 endpoint addresses. All endpoint addresses have one input and one output endpoint, for a total of 16 endpoints. Each endpoint is fully configurable in any of the four transfer types: control, interrupt, bulk or isochronous. The USB host mode supports up to 8 pipes. The maximum data payload size is selectable up to 1023 bytes.

Internal SRAM is used to keep the configuration and data buffer for each endpoint. The memory locations used for the endpoint configurations and data buffers is fully configurable. The amount of memory allocated is dynamic according to the number of endpoints in use, and the configuration of these. The USB module has a built-in Direct Memory Access (DMA) and will read/write data from/to the system RAM when a USB transaction takes place. No CPU or DMA Controller resources are required.

To maximize throughput, an endpoint can be configured for ping-pong operation. When this is done the input and output endpoint with the same address are used in the same direction. The CPU or DMA Controller can then read/write one data buffer while the USB module writes/reads from the other buffer. This gives double buffered communication.

Multi-packet transfer enables a data payload exceeding the maximum packet size of an endpoint to be transferred as multiple packets without any software intervention. This reduces the number of interrupts and software intervention needed for USB transfers.

For low power operation the USB module can put the microcontroller in any sleep mode when the USB bus is idle and a suspend condition is given. Upon bus resume, the USB module can wake the microcontroller from any sleep mode.

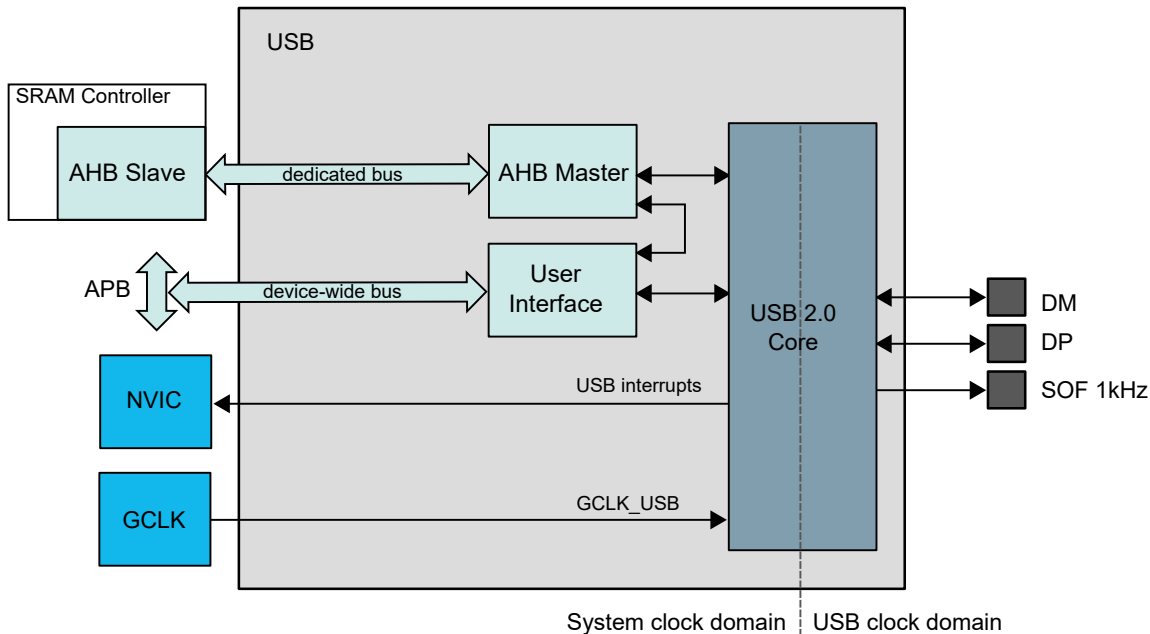
### 38.2 Features

- Compatible with the USB 2.1 specification
- USB Embedded Host and Device mode
- Supports full (12Mbit/s) and low (1.5Mbit/s) speed communication
- Supports Link Power Management (LPM-L1) protocol
- On-chip transceivers with built-in pull-ups and pull-downs
- On-Chip USB serial resistors
- 1kHz SOF clock available on external pin
- Device mode
  - Supports 8 IN endpoints and 8 OUT endpoints
  - No endpoint size limitations
  - Built-in DMA with multi-packet and dual bank for all endpoints
  - Supports feedback endpoint
  - Supports crystal less clock
- Host mode
  - Supports 8 physical pipes

- No pipe size limitations
- Supports multiplexed virtual pipe on one physical pipe to allow an unlimited USB tree
- Built-in DMA with multi-packet support and dual bank for all pipes
- Supports feedback endpoint
- Supports the USB 2.0 Phase-locked SOFs feature

### 38.3 USB Block Diagram

Figure 38-1. LS/FS Implementation: USB Block Diagram



### 38.4 Signal Description

Pin Name	Pin Description	Type
DM	Data -: Differential Data Line - Port	Input/Output
DP	Data +: Differential Data Line + Port	Input/Output
SOF 1kHz	SOF Output	Output

Refer to *I/O Multiplexing and Considerations* for details on the pin mapping for this peripheral. One signal can be mapped on several pins.

#### Related Links

[6. I/O Multiplexing and Considerations](#)

### 38.5 Product Dependencies

In order to use this peripheral module, other parts of the system must be configured correctly, as described below.

### 38.5.1 I/O Lines

The USB pins may be multiplexed with the I/O lines Controller. The user must first configure the I/O Controller to assign the USB pins to their peripheral functions.

A 1kHz SOF clock is available on an external pin. The user must first configure the I/O Controller to assign the 1kHz SOF clock to the peripheral function. The SOF clock is available for device and host mode.

### 38.5.2 Power Management

This peripheral can continue to operate in any Sleep mode where its source clock is running. The interrupts can wake up the device from Sleep modes. Events connected to the event system can trigger other operations in the system without exiting Sleep modes.

#### Related Links

[18. PM – Power Manager](#)

### 38.5.3 Clocks

The USB bus clock (CLK\_USB\_AHB) can be enabled and disabled in the Main Clock module, MCLK, and the default state of CLK\_USB\_AHB can be found in the *Peripheral Clock Masking*.

A generic clock (GCLK\_USB) is required to clock the USB. This clock must be configured and enabled in the Generic Clock Controller before using the USB.

This generic clock is asynchronous to the bus clock (CLK\_USB\_AHB). Due to this asynchronicity, writes to certain registers will require synchronization between the clock domains.

The USB module requires a GCLK\_USB of 48 MHz  $\pm$  0.25% clock for low speed and full speed operation. To follow the USB data rate at 12 Mbit/s in full-speed mode, the CLK\_USB\_AHB clock should be at minimum 8 MHz.

Clock recovery is achieved by a digital phase-locked loop in the USB module, which complies with the USB jitter specifications. If crystal-less operation is used in USB device mode, refer to *USB Clock Recovery Module*.

#### Related Links

[14. GCLK - Generic Clock Controller](#)

[14.6.6 Synchronization](#)

[15.8.7 AHBMASK](#)

[28.6.4.2 Additional Features](#)

### 38.5.4 DMA

The USB has a built-in Direct Memory Access (DMA) and will read/write data to/from the system RAM when a USB transaction takes place. No CPU or DMA Controller resources are required.

### 38.5.5 Interrupts

The interrupt request line is connected to the Interrupt Controller. In order to use interrupt requests of this peripheral, the Interrupt Controller (NVIC) must be configured first. Refer to *Nested Vector Interrupt Controller* for details.

#### Related Links

[10.2 Nested Vector Interrupt Controller](#)

### 38.5.6 Events

Not applicable.

### 38.5.7 Debug Operation

When the CPU is halted in debug mode the USB peripheral continues normal operation. If the USB peripheral is configured in a way that requires it to be periodically serviced by the CPU through interrupts or similar, improper operation or data loss may result during debugging.

### 38.5.8 Register Access Protection

Registers with write access can be optionally write-protected by the Peripheral Access Controller (PAC), except for the following:

- Device Interrupt Flag (INTFLAG) register
- Endpoint Interrupt Flag (EPINTFLAG) register
- Host Interrupt Flag (INTFLAG) register
- Pipe Interrupt Flag (PINTFLAG) register

**Note:** Optional write protection is indicated by the "PAC Write Protection" property in the register description.

Write protection does not apply for accesses through an external debugger.

### 38.5.9 Analog Connections

Not applicable.

### 38.5.10 Calibration

The output drivers for the DP/DM USB line interface can be fine tuned with calibration values from production tests. The calibration values must be loaded from the NVM Software Calibration Area into the USB Pad Calibration register (PADCAL) by software, before enabling the USB, to achieve the specified accuracy. Refer to *NVM Software Calibration Area Mapping* for further details.

For details on Pad Calibration, refer to Pad Calibration ([38.8.1.6 PADCAL](#)) register.

## 38.6 Functional Description

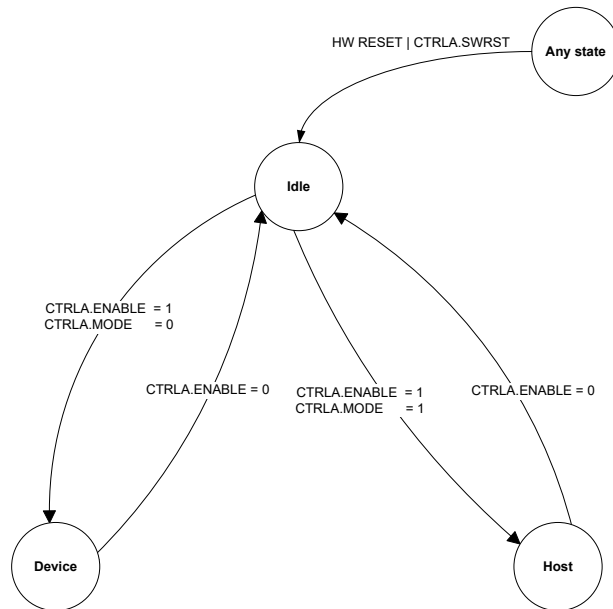
### 38.6.1 USB General Operation

#### 38.6.1.1 Initialization

After a hardware reset, the USB is disabled. The user should first enable the USB (CTRLA.ENABLE) in either device mode or host mode (CTRLA.MODE).



Figure 38-2. General States



After a hardware reset, the USB is in the idle state. In this state:

- The module is disabled. The USB Enable bit in the Control A register (CTRLA.ENABLE) is reset.
- The module clock is stopped in order to minimize power consumption.
- The USB pad is in suspend mode.
- The internal states and registers of the device and host are reset.

Before using the USB, the Pad Calibration register (PADCAL) must be loaded with production calibration values from the NVM Software Calibration Area.

The USB is enabled by writing a '1' to CTRLA.ENABLE. The USB is disabled by writing a '0' to CTRLA.ENABLE.

The USB is reset by writing a '1' to the Software Reset bit in CTRLA (CTRLA.SWRST). All registers in the USB will be reset to their initial state, and the USB will be disabled. Refer to the CTRLA register for details.

The user can configure pads and speed before enabling the USB by writing to the Operating Mode bit in the Control A register (CTRLA.MODE) and the Speed Configuration field in the Control B register (CTRLB.SPDCONF). These values are taken into account once the USB has been enabled by writing a '1' to CTRLA.ENABLE.

After writing a '1' to CTRLA.ENABLE, the USB enters device mode or host mode (according to CTRLA.MODE).

The USB can be disabled at any time by writing a '0' to CTRLA.ENABLE.

Refer to [38.6.2 USB Device Operations](#) for the basic operation of the device mode.

Refer to [38.6.3 Host Operations](#) for the basic operation of the host mode.

### 38.6.2 USB Device Operations

This section gives an overview of the USB module device operation during normal transactions. For more details on general USB and USB protocol, refer to the Universal Serial Bus specification revision 2.1.

#### 38.6.2.1 Initialization

To attach the USB device to start the USB communications from the USB host, a zero should be written to the Detach bit in the Device Control B register (CTRLB.DETACH). To detach the device from the USB host, a one must be written to the CTRLB.DETACH.

After the device is attached, the host will request the USB device descriptor using the default device address zero. On successful transmission, it will send a USB reset. After that, it sends an address to be configured for the device. All further transactions will be directed to this device address. This address should be configured in the Device Address field in the Device Address register (DADD.DADD) and the Address Enable bit in DADD (DADD.ADDEN) should be written to one to accept communications directed to this address. DADD.ADDEN is automatically cleared on receiving a USB reset.

#### 38.6.2.2 Endpoint Configuration

Endpoint data can be placed anywhere in the device RAM. The USB controller accesses these endpoints directly through the AHB master (built-in DMA) with the help of the endpoint descriptors. The base address of the endpoint descriptors needs to be written in the Descriptor Address register (DESCADD) by the user. Refer also to the Endpoint Descriptor structure in [38.8.4.1 Endpoint Descriptor Structure](#).

Before using an endpoint, the user should configure the direction and type of the endpoint in Type of Endpoint field in the Device Endpoint Configuration register (EPCFG.EPTYPE0/1). The endpoint descriptor registers should be initialized to known values before using the endpoint, so that the USB controller does not read random values from the RAM.

The Endpoint Size field in the Packet Size register (PCKSIZE.SIZE) should be configured as per the size reported to the host for that endpoint. The Address of Data Buffer register (ADDR) should be set to the data buffer used for endpoint transfers.

The RAM Access Interrupt bit in Device Interrupt Flag register (INTFLAG.RAMACER) is set when a RAM access underflow error occurs during IN data stage.

When an endpoint is disabled, the following registers are cleared for that endpoint:

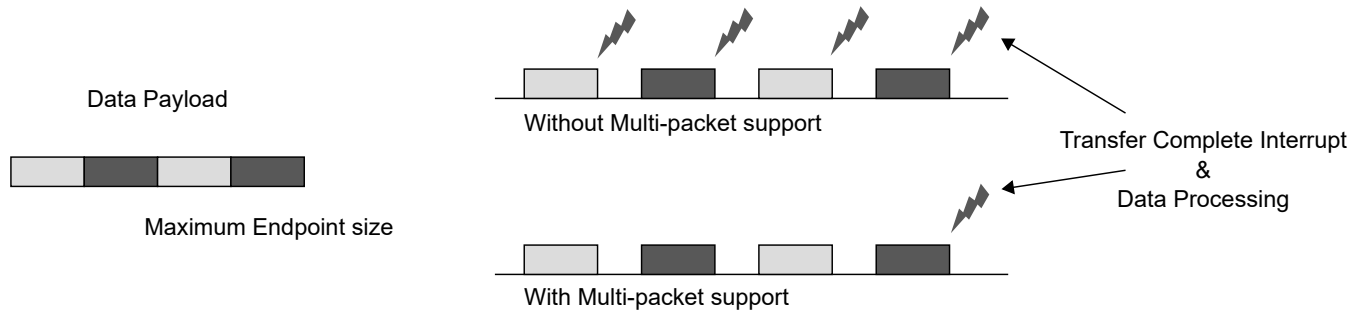
- Device Endpoint Interrupt Enable Clear/Set (EPINTENCLR/SET) register
- Device Endpoint Interrupt Flag (EPINTFLAG) register
- Transmit Stall 0 bit in the Endpoint Status register (EPSTATUS.STALLRQ0)
- Transmit Stall 1 bit in the Endpoint Status register (EPSTATUS.STALLRQ1)

#### 38.6.2.3 Multi-Packet Transfers

Multi-packet transfer enables a data payload exceeding the endpoint maximum transfer size to be transferred as multiple packets without software intervention. This reduces the number of interrupts and software intervention required to manage higher level USB transfers. Multi-packet transfer is identical to the IN and OUT transactions described below unless otherwise noted in this section.

The application software provides the size and address of the RAM buffer to be proceeded by the USB module for a specific endpoint, and the USB module will split the buffer in the required USB data transfers without any software intervention.

**Figure 38-3. Multi-Packet Feature - Reduction of CPU Overhead**



#### 38.6.2.4 USB Reset

The USB bus reset is initiated by a connected host and managed by hardware.

During USB reset the following registers are cleared:

- Device Endpoint Configuration (EPCFG) register - except for Endpoint 0
- Device Frame Number (FNUM) register
- Device Address (DADD) register
- Device Endpoint Interrupt Enable Clear/Set (EPINTENCLR/SET) register
- Device Endpoint Interrupt Flag (EPINTFLAG) register
- Transmit Stall 0 bit in the Endpoint Status register (EPSTATUS.STALLRQ0)
- Transmit Stall 1 bit in the Endpoint Status register (EPSTATUS.STALLRQ1)
- Endpoint Interrupt Summary (EPINTSMRY) register
- Upstream resume bit in the Control B register (CTRLB.UPRSM)

At the end of the reset process, the End of Reset bit is set in the Interrupt Flag register (INTFLAG.EORST).

#### 38.6.2.5 Start-of-Frame

When a Start-of-Frame (SOF) token is detected, the frame number from the token is stored in the Frame Number field in the Device Frame Number register (FNUM.FNUM), and the Start-of-Frame interrupt bit in the Device Interrupt Flag register (INTFLAG.SOF) is set. If there is a CRC or bit-stuff error, the Frame Number Error status flag (FNUM.FNCERR) in the FNUM register is set.

#### 38.6.2.6 Management of SETUP Transactions

When a SETUP token is detected and the device address of the token packet does not match DADD.DADD, the packet is discarded and the USB module returns to idle and waits for the next token packet.

When the address matches, the USB module checks if the endpoint is enabled in EPCFG. If the addressed endpoint is disabled, the packet is discarded and the USB module returns to idle and waits for the next token packet.

When the endpoint is enabled, the USB module then checks on the EPCFG of the addressed endpoint. If the EPCFG.EPTYPE0 is not set to control, the USB module returns to idle and waits for the next token packet.

When the EPCFG.EPTYPE0 matches, the USB module then fetches the Data Buffer Address (ADDR) from the addressed endpoint's descriptor and waits for a DATA0 packet. If a PID error or any other PID than DATA0 is detected, the USB module returns to idle and waits for the next token packet.

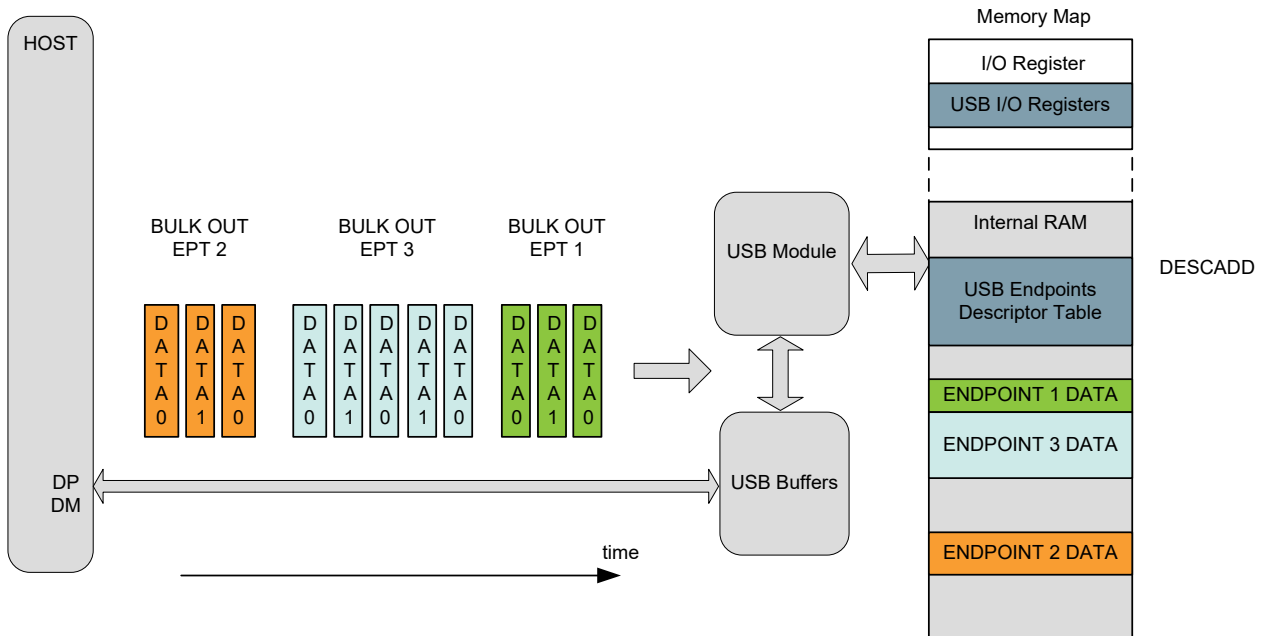
When the data PID matches and if the Received Setup Complete interrupt bit in the Device Endpoint Interrupt Flag register (EPINTFLAG.RXSTP) is equal to zero, ignoring the Bank 0 Ready bit in the Device Endpoint Status register (EPSTATUS.BK0RDY), the incoming data is written to the data buffer pointed to by the Data Buffer Address (ADDR). If the number of received data bytes exceeds the endpoint's maximum data payload size as specified by the PCKSIZE.SIZE, the remainders of the received data bytes are discarded. The packet will still be checked for bit-stuff and CRC errors. Software must never report a endpoint size to the host that is greater than the value configured in PCKSIZE.SIZE. If a bit-stuff or CRC error is detected in the packet, the USB module returns to idle and waits for the next token packet.

If data is successfully received, an ACK handshake is returned to the host, and the number of received data bytes, excluding the CRC, is written to the Byte Count (PCKSIZE.BYTE\_COUNT). If the number of received data bytes is the maximum data payload specified by PCKSIZE.SIZE, no CRC data is written to the data buffer. If the number of received data bytes is the maximum data payload specified by PCKSIZE.SIZE minus one, only the first CRC data is written to the data buffer. If the number of received data is equal or less than the data payload specified by PCKSIZE.SIZE minus two, both CRC data bytes are written to the data buffer.

Finally the EPSTATUS is updated. Data Toggle OUT bit (EPSTATUS.DTGLOUT), the Data Toggle IN bit (EPSTATUS.DTGLIN), the current bank bit (EPSTATUS.CURRBK) and the Bank Ready 0 bit (EPSTATUS.BK0RDY) are set. Bank Ready 1 bit (EPSTATUS.BK1RDY) and the Stall Bank 0/1 bit (EPSTATUS.STALLQR0/1) are cleared on receiving the SETUP request. The RXSTP bit is set and triggers an interrupt if the Received Setup Interrupt Enable bit is set in Endpoint Interrupt Enable Set/Clear register (EPINTENSET/CLR.RXSTP).

### 38.6.2.7 Management of OUT Transactions

**Figure 38-4. OUT Transfer: Data Packet Host to USB Device**



When an OUT token is detected, and the device address of the token packet does not match DADD.DADD, the packet is discarded and the USB module returns to idle and waits for the next token packet.

If the address matches, the USB module checks if the endpoint number received is enabled in the EPCFG of the addressed endpoint. If the addressed endpoint is disabled, the packet is discarded and the USB module returns to idle and waits for the next token packet.

When the endpoint is enabled, the USB module then checks the Endpoint Configuration register (EPCFG) of the addressed output endpoint. If the type of the endpoint (EPCFG.EPTYPE0) is not set to OUT, the USB module returns to idle and waits for the next token packet.

The USB module then fetches the Data Buffer Address (ADDR) from the addressed endpoint's descriptor, and waits for a DATA0 or DATA1 packet. If a PID error or any other PID than DATA0 or DATA1 is detected, the USB module returns to idle and waits for the next token packet.

If EPSTATUS.STALLRQ0 in EPSTATUS is set, the incoming data is discarded. If the endpoint is not isochronous, a STALL handshake is returned to the host and the Transmit Stall Bank 0 interrupt bit in EPINTFLAG (EPINTFLAG.STALL0) is set.

For isochronous endpoints, data from both a DATA0 and DATA1 packet will be accepted. For other endpoint types the PID is checked against EPSTATUS.DTGLOUT. If a PID mismatch occurs, the incoming data is discarded, and an ACK handshake is returned to the host.

If EPSTATUS.BK0RDY is set, the incoming data is discarded, the bit Transmit Fail 0 interrupt bit in EPINTFLAG (EPINTFLAG.TRFAIL0) and the status bit STATUS\_BK.ERRORFLOW are set. If the endpoint is not isochronous, a NAK handshake is returned to the host.

The incoming data is written to the data buffer pointed to by the Data Buffer Address (ADDR). If the number of received data bytes exceeds the maximum data payload specified as PCKSIZE.SIZE, the remainders of the received data bytes are discarded. The packet will still be checked for bit-stuff and CRC errors. If a bit-stuff or CRC error is detected in the packet, the USB module returns to idle and waits for the next token packet.

If the endpoint is isochronous and a bit-stuff or CRC error in the incoming data, the number of received data bytes, excluding CRC, is written to PCKSIZE.BYTE\_COUNT. Finally the EPINTFLAG.TRFAIL0 and CRC Error bit in the Device Bank Status register (STATUS\_BK.CRCERR) is set for the addressed endpoint.

If data was successfully received, an ACK handshake is returned to the host if the endpoint is not isochronous, and the number of received data bytes, excluding CRC, is written to PCKSIZE.BYTE\_COUNT. If the number of received data bytes is the maximum data payload specified by PCKSIZE.SIZE no CRC data bytes are written to the data buffer. If the number of received data bytes is the maximum data payload specified by PCKSIZE.SIZE minus one, only the first CRC data byte is written to the data buffer. If the number of received data is equal or less than the data payload specified by PCKSIZE.SIZE minus two, both CRC data bytes are written to the data buffer.

Finally in EPSTATUS for the addressed output endpoint, EPSTATUS.BK0RDY is set and EPSTATUS.DTGLOUT is toggled if the endpoint is not isochronous. The flag Transmit Complete 0 interrupt bit in EPINTFLAG (EPINTFLAG.TRCPT0) is set for the addressed endpoint.

### 38.6.2.8 Multi-Packet Transfers for OUT Endpoint

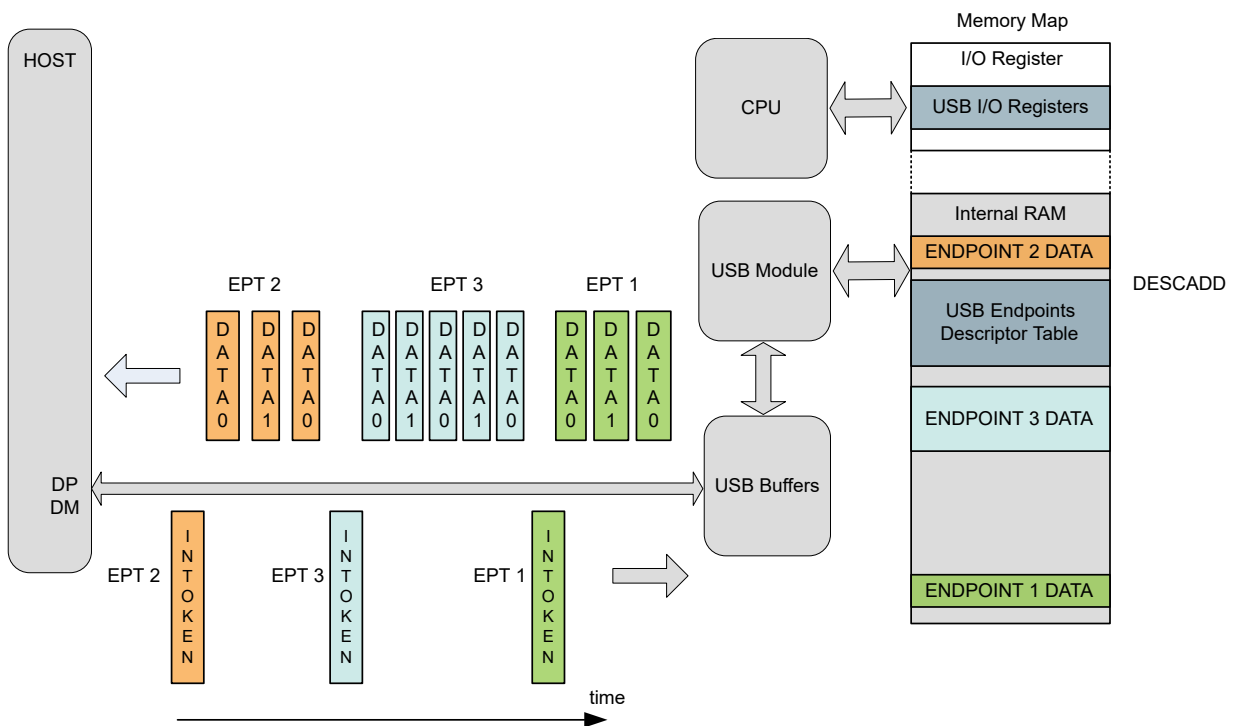
The number of data bytes received is stored in endpoint PCKSIZE.BYTE\_COUNT as for normal operation. Since PCKSIZE.BYTE\_COUNT is updated after each transaction, it must be set to zero when setting up a new transfer. The total number of bytes to be received must be written to PCKSIZE.MULTI\_PACKET\_SIZE. This value must be a multiple of PCKSIZE.SIZE, otherwise excess data may be written to SRAM locations used by other parts of the application.

EPSTATUS.DTGLOUT management for non-isochronous packets and EPINTFLAG.BK1RDY/BK0RDY management are as for normal operation.

If a maximum payload size packet is received, PCKSIZE.BYTE\_COUNT will be incremented by PCKSIZE.SIZE after the transaction has completed, and EPSTATUS.DTGLOUT will be toggled if the endpoint is not isochronous. If the updated PCKSIZE.BYTE\_COUNT is equal to PCKSIZE.MULTI\_PACKET\_SIZE (i.e. the last transaction), EPSTATUS.BK1RDY/BK0RDY, and EPINTFLAG.TRCPT0/TRCPT1 will be set.

### 38.6.2.9 Management of IN Transactions

**Figure 38-5. IN Transfer: Data Packet USB Device to Host After Request from Host**



When an IN token is detected, and if the device address of the token packet does not match DADD.DADD, the packet is discarded and the USB module returns to idle and waits for the next token packet.

When the address matches, the USB module checks if the endpoint received is enabled in the EPCFG of the addressed endpoint and if not, the packet is discarded and the USB module returns to idle and waits for the next token packet.

When the endpoint is enabled, the USB module then checks on the EPCFG of the addressed input endpoint. If the EPCFG.EPTYPE1 is not set to IN, the USB module returns to idle and waits for the next token packet.

If EPSTATUS.STALLRQ1 in EPSTATUS is set, and the endpoint is not isochronous, a STALL handshake is returned to the host and EPINTFLAG.STALL1 is set.

If EPSTATUS.BK1RDY is cleared, the flag EPINTFLAG.TRFAIL1 is set. If the endpoint is not isochronous, a NAK handshake is returned to the host.

The USB module then fetches the Data Buffer Address (ADDR) from the addressed endpoint's descriptor. The data pointed to by the Data Buffer Address (ADDR) is sent to the host in a DATA0 packet if the endpoint is isochronous. For non-isochronous endpoints a DATA0 or DATA1 packet is sent depending on the state of EPSTATUS.DTGLIN. When the number of data bytes specified in endpoint PCKSIZE.BYTE\_COUNT is sent, the CRC is appended and sent to the host.

For isochronous endpoints, EPSTATUS.BK1RDY is cleared and EPINTFLAG.TRCPT1 is set.

For all non-isochronous endpoints the USB module waits for an ACK handshake from the host. If an ACK handshake is not received within 16 bit times, the USB module returns to idle and waits for the next token packet. If an ACK handshake is successfully received EPSTATUS.BK1RDY is cleared, EPINTFLAG.TRCPT1 is set and EPSTATUS.DTGLIN is toggled.

### 38.6.2.10 Multi-Packet Transfers for IN Endpoint

The total number of data bytes to be sent is written to PCKSIZE.BYTE\_COUNT as for normal operation. The Multi-packet size register (PCKSIZE.MULTI\_PACKET\_SIZE) is used to store the number of bytes that are sent, and must be written to zero when setting up a new transfer.

When an IN token is received, PCKSIZE.BYTE\_COUNT and PCKSIZE.MULTI\_PACKET\_SIZE are fetched. If PCKSIZE.BYTE\_COUNT minus PCKSIZE.MULTI\_PACKET\_SIZE is less than the endpoint PCKSIZE.SIZE, endpoint BYTE\_COUNT minus endpoint PCKSIZE.MULTI\_PACKET\_SIZE bytes are transmitted, otherwise PCKSIZE.SIZE number of bytes are transmitted. If endpoint PCKSIZE.BYTE\_COUNT is a multiple of PCKSIZE.SIZE, the last packet sent will be zero-length if the AUTOZLP bit is set.

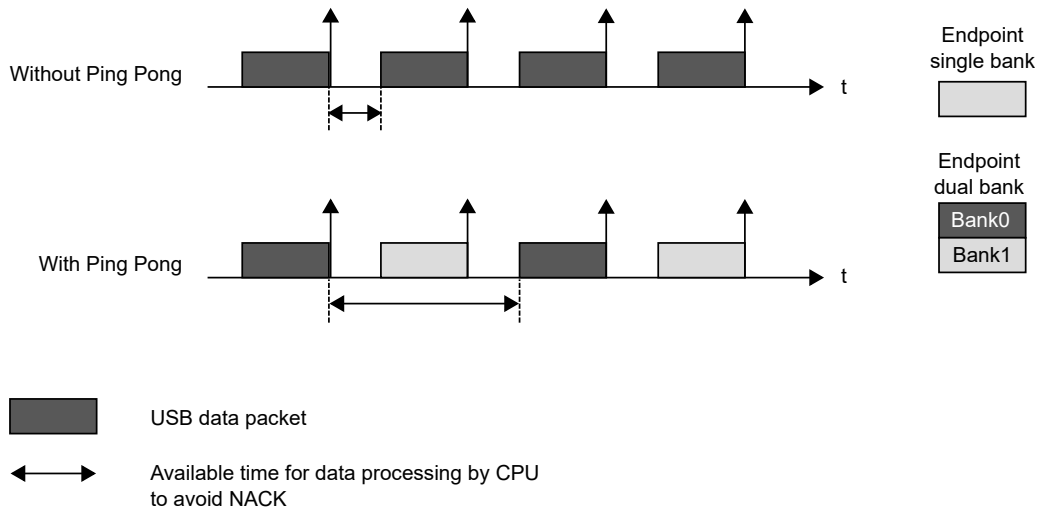
If a maximum payload size packet was sent (i.e. not the last transaction), MULTI\_PACKET\_SIZE will be incremented by the PCKSIZE.SIZE. If the endpoint is not isochronous the EPSTATUS.DTGLIN bit will be toggled when the transaction has completed. If a short packet was sent (i.e. the last transaction), MULTI\_PACKET\_SIZE is incremented by the data payload. EPSTATUS.BK0/1RDY will be cleared and EPINTFLAG.TRCPT0/1 will be set.

### 38.6.2.11 Ping-Pong Operation

When an endpoint is configured for ping-pong operation, it uses both the input and output data buffers (banks) for a given endpoint in a single direction. The direction is selected by enabling one of the IN or OUT direction in EPCFG.EPTYPE0/1 and configuring the opposite direction in EPCFG.EPTYPE1/0 as Dual Bank.

When ping-pong operation is enabled for an endpoint, the endpoint in the opposite direction must be configured as dual bank. The data buffer, data address pointer and byte counter from the enabled endpoint are used as Bank 0, while the matching registers from the disabled endpoint are used as Bank 1.

**Figure 38-6. Ping-Pong Overview**



The Bank Select flag in EPSTATUS.CURBK indicates which bank data will be used in the next transaction, and is updated after each transaction. According to EPSTATUS.CURBK, EPINTFLAG.TRCPT0 or EPINTFLAG.TRFAIL0 or EPINTFLAG.TRCPT1 or EPINTFLAG.TRFAIL1 in EPINTFLAG and Data Buffer 0/1 ready (EPSTATUS.BK0RDY and EPSTATUS.BK1RDY) are set. The EPSTATUS.DTGLOUT and EPSTATUS.DTGLIN are updated for the enabled endpoint direction only.

### 38.6.2.12 Feedback Operation

Feedback endpoints are endpoints with same the address but in different directions. This is usually used in explicit feedback mechanism in USB Audio, where a feedback endpoint is associated to one or more isochronous data endpoints to which it provides feedback service. The feedback endpoint always has the opposite direction from the data endpoint.

The feedback endpoint always has the opposite direction from the data endpoint(s). The feedback endpoint has the same endpoint number as the first (lower) data endpoint. A feedback endpoint can be created by configuring an endpoint with different endpoint size (PCKSIZE.SIZE) and different endpoint type (EPCFG.EPTYPE0/1) for the IN and OUT direction.

Example Configuration for Feedback Operation:

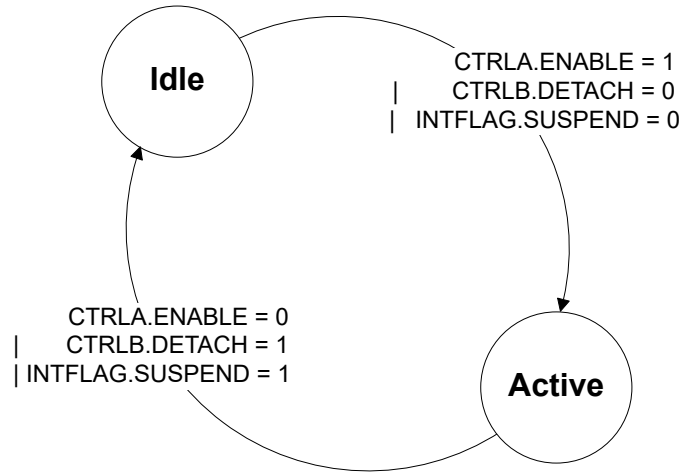
- Endpoint n / IN: EPCFG.EPTYPE1 = Interrupt IN, PCKSIZE.SIZE = 64.
- Endpoint n / OUT: EPCFG.EPTYPE0= Isochronous OUT, PCKSIZE.SIZE = 512.

### 38.6.2.13 Suspend State and Pad Behavior

The following figure, Pad Behavior, illustrates the behavior of the USB pad in Device mode.



**Figure 38-7. Pad Behavior**

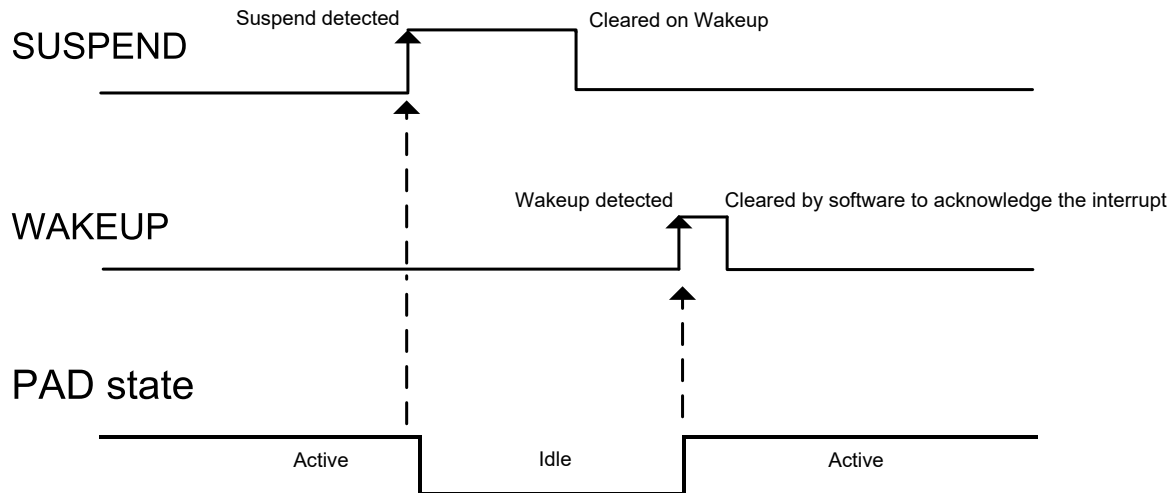


In Idle state, the pad is in Low Power Consumption mode.

In Active state, the pad is active.

The following figure, Pad Events, illustrates the pad events leading to a PAD state change.

**Figure 38-8. Pad Events**



The Suspend Interrupt bit in the Device Interrupt Flag register (INTFLAG.SUSPEND) is set when a USB Suspend state has been detected on the USB bus. The USB pad is then automatically put in the Idle state. The detection of a non-idle state sets the Wake Up Interrupt bit (INTFLAG.WAKEUP) and wakes the USB pad.

The pad goes to the Idle state if the USB module is disabled or if CTRLB.DETACH is written to one. It returns to the Active state when CTRLA.ENABLE is written to one and CTRLB.DETACH is written to zero.

### 38.6.2.14 Remote Wakeup

The remote wakeup request (also known as upstream resume) is the only request the device may send on its own initiative. This should be preceded by a DEVICE\_REMOTE\_WAKEUP request from the host.

First, the USB must have detected a “Suspend” state on the bus, i.e. the remote wakeup request can only be sent after INTFLAG.SUSPEND has been set.

The user may then write a one to the Remote Wakeup bit (CTRLB.UPRSM) to send an Upstream Resume to the host initiating the wakeup. This will automatically be done by the controller after 5 ms of inactivity on the USB bus.

When the controller sends the Upstream Resume INTFLAG.WAKEUP is set and INTFLAG.SUSPEND is cleared.

The CTRLB.UPRSM is cleared at the end of the transmitting Upstream Resume.

In case of a rebroadcast resume initiated by the host, the End of Resume bit (INTFLAG.EORSM) flag is set when the rebroadcast resume is completed.

In the case where the CTRLB.UPRSM bit is set while a host initiated downstream resume is already started, the CTRLB.UPRSM is cleared and the upstream resume request is ignored.

### 38.6.2.15 Link Power Management L1 (LPM-L1) Suspend State Entry and Exit as Device

The LPM Handshake bit in CTRLB.LPMHDSK should be configured to accept the LPM transaction.

When a LPM transaction is received on any enabled endpoint *n* and a handshake has been sent in response by the controller according to CTRLB.LPMHDSK, the Device Link Power Manager (EXTREG) register is updated in the bank 0 of the addressed endpoint's descriptor. It contains information such as the Best Effort Service Latency (BESL), the Remote Wake bit (bRemoteWake), and the Link State parameter (bLinkState). Usually, the LPM transaction uses only the endpoint number 0.

If the LPM transaction was positively acknowledged (ACK handshake), USB sets the Link Power Management Interrupt bit (INTFLAG.LPMSUSP) bit which indicates that the USB transceiver is suspended, reducing power consumption. This suspend occurs 9 microseconds after the LPM transaction according to the specification.

To further reduce consumption, it is recommended to stop the USB clock while the device is suspended.

The MCU can also enter in one of the available sleep modes if the wakeup time latency of the selected sleep mode complies with the host latency constraint (see the BESL parameter in [38.8.4.4 EXTREG](#) register).

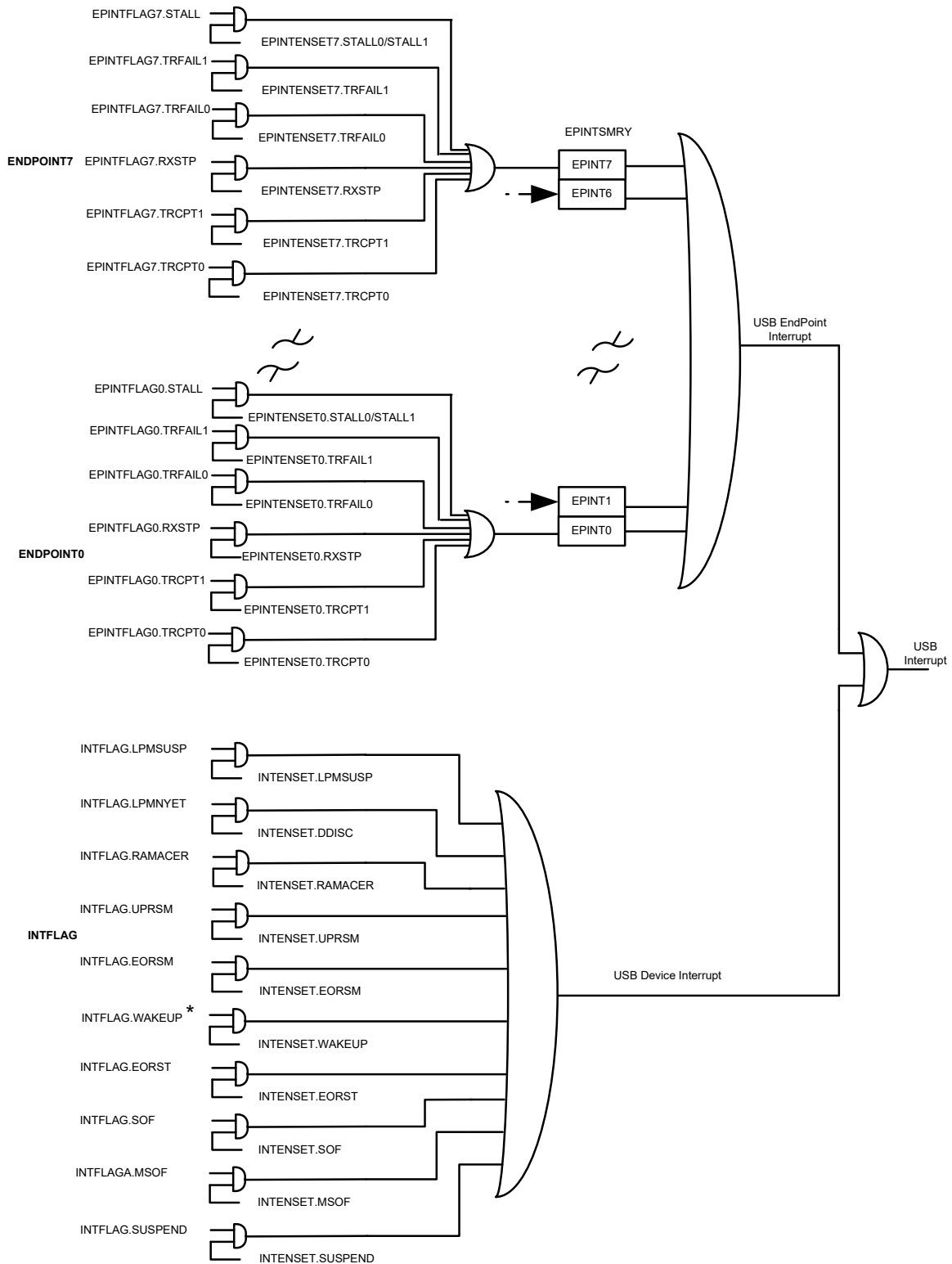
Recovering from this LPM-L1 suspend state is exactly the same as the Suspend state (see Section [38.6.2.13 Suspend State and Pad Behavior](#)) except that the remote wakeup duration initiated by USB is shorter to comply with the Link Power Management specification.

If the LPM transaction is responded with a NYET, the Link Power Management Not Yet Interrupt Flag (INTFLAG.LPMNYET) is set. This generates an interrupt if the Link Power Management Not Yet Interrupt Enable bit (INTENCLR/SET.LPMNYET) is set.

If the LPM transaction is responded with a STALL or no handshake, no flag is set, and the transaction is ignored.

### 38.6.2.16 USB Device Interrupt

**Figure 38-9. Device Interrupt**



\* Asynchronous interrupt

The WAKEUP is an asynchronous interrupt and can be used to wake-up the device from any sleep mode.

### 38.6.3 Host Operations

This section gives an overview of the USB module Host operation during normal transactions. For more details on general USB and USB protocol, refer to Universal Serial Bus Specification revision 2.1.

#### 38.6.3.1 Device Detection and Disconnection

Prior to device detection the software must set the VBUS is OK bit (CTRLB.VBUSOK) register when the VBUS is available. This notifies the USB host that USB operations can be started. When the bit CTRLB.VBUSOK is zero and even if the USB HOST is configured and enabled, host operation is halted. Setting the bit CTRLB.VBUSOK will allow host operation when the USB is configured.

The Device detection is managed by the software using the Line State field in the Host Status (STATUS.LINESTATE) register. The device connection is detected by the host controller when DP or DM is pulled high, depending of the speed of the device.

The device disconnection is detected by the host controller when both DP and DM are pulled down using the STATUS.LINESTATE registers.

The Device Connection Interrupt bit (INTFLAG.DCONN) is set if a device connection is detected.

The Device Disconnection Interrupt bit (INTFLAG.DDISC) is set if a device disconnection is detected.

#### 38.6.3.2 Host Terminology

In host mode, the term pipe is used instead of endpoint. A host pipe corresponds to a device endpoint, refer to "Universal Serial Bus Specification revision 2.1." for more information.

#### 38.6.3.3 USB Reset

The USB sends a USB reset signal when the user writes a one to the USB Reset bit (CTRLB.BUSRESET). When the USB reset has been sent, the USB Reset Sent Interrupt bit in the INTFLAG (INTFLAG.RST) is set and all pipes will be disabled.

If the bus was previously in a suspended state (i.e., the Start of Frame Generation Enable bit (CTRLB.SOFE) is zero), the USB will switch it to the Resume state, causing the bus to asynchronously set the Host Wakeup Interrupt flag (INTFLAG.WAKEUP). The CTRLB.SOFE bit will be set in order to generate SOFs immediately after the USB reset.

During USB reset the following registers are cleared:

- All Host Pipe Configuration register (PCFG)
- Host Frame Number register (FNUM)
- Interval for the Bulk-Out/Ping transaction register (BINTERVAL)
- Host Start-of-Frame Control register (HSOFC)
- Pipe Interrupt Enable Clear/Set register (PINTENCLR/SET)
- Pipe Interrupt Flag register (PINTFLAG)
- Pipe Freeze bit in Pipe Status register (PSTATUS.FREEZE)

After the reset the user should check the Speed Status field in the Status register (STATUS.SPEED) to find out the current speed according to the capability of the peripheral.

#### 38.6.3.4 Pipe Configuration

Pipe data can be placed anywhere in the RAM. The USB controller accesses these pipes directly through the AHB master (built-in DMA) with the help of the pipe descriptors. The base address of the pipe descriptors needs to be written in the Descriptor Address register (DESCADD) by the user. Refer also to [38.8.7.1 Pipe Descriptor Structure](#).

Before using a pipe, the user should configure the direction and type of the pipe in Type of Pipe field in the Host Pipe Configuration register (PCFG.PTYPE). The pipe descriptor registers should be initialized to

known values before using the pipe, so that the USB controller does not read the random values from the RAM.

The Pipe Size field in the Packet Size register (PCKSIZE.SIZE) should be configured as per the size reported by the device for the endpoint associated with this pipe. The Address of Data Buffer register (ADDR) should be set to the data buffer used for pipe transfers.

The Pipe Bank bit (PCFG.BK) should be set to one if dual banking is desired. Dual bank is not supported for Control pipes.

The Ram Access Interrupt bit in Host Interrupt Flag register (INTFLAG.RAMACER) is set when a RAM access underflow error occurs during an OUT stage.

When a pipe is disabled, the following registers are cleared for that pipe:

- Interval for the Bulk-Out/Ping transaction register (BINTERVAL)
- Pipe Interrupt Enable Clear/Set register (PINTENCLR/SET)
- Pipe Interrupt Flag register (PINTFLAG)
- Pipe Freeze bit in Pipe Status register (PSTATUS.FREEZE)

### 38.6.3.5 Pipe Activation

A disabled pipe is inactive, and will be reset along with its context registers (pipe registers for the pipe n). Pipes are enabled by writing the Type of the Pipe bit (PCFG.PTYPE) to a value different than 0x0 (disabled).

When a pipe is enabled, the Pipe Freeze bit in the Pipe Status register (PSTATUS.FREEZE) is set. This allows the user to complete the configuration of the pipe, without starting a USB transfer.

When starting an enumeration, the user retrieves the device descriptor by sending a GET\_DESCRIPTOR USB request. This descriptor contains the maximal packet size of the device default control endpoint (bMaxPacketSize0), which the user should use to reconfigure the size of the default control pipe.

### 38.6.3.6 Pipe Address Setup

Once the device has answered the first host requests with the default device address 0, the host assigns a new address to the device. The host controller has to send a USB reset to the device and a SET\_ADDRESS(addr) SETUP request with the new address to be used by the device. Once this SETUP transaction is complete, the user writes the new address to the Pipe Device Address field in the Host Control Pipe register (CTRL\_PIPE.PDADDR) in Pipe descriptor. All following requests by this pipe will be performed using this new address.

### 38.6.3.7 Suspend and Wakeup

Setting CTRLB.SOFE to zero when in host mode will cause the USB to cease sending Start-of-Frames on the USB bus and enter the Suspend state. The USB device will enter the Suspend state 3ms later.

Before entering suspend by writing CTRLB.SOFE to zero, the user must freeze the active pipes by setting their PSTATUS.FREEZE bit. Any current on-going pipe will complete its transaction, and then all pipes will be inactive. The user should wait at least 1 complete frame before entering the suspend mode to avoid any data loss.

The device can awaken the host by sending an Upstream Resume (Remote Wakeup feature). When the host detects a non-idle state on the USB bus, it sets the INTFLAG.WAKEUP. If the non-idle bus state corresponds to an Upstream Resume (K state), the Upstream Resume Received Interrupt bit in INTFLAG (INTFLAG.UPRSM) is set and the user must generate a Downstream Resume within 1 ms and for at least 20 ms. It is required to first write a one to the Send USB Resume bit in CTRLB (CTRLB.RESUME) to respond to the upstream resume with a downstream resume. Alternatively, the host can resume from a

suspend state by sending a Downstream Resume on the USB bus (CTRLB.RESUME set to 1). In both cases, when the downstream resume is completed, the CTRLB.SOFE bit is automatically set and the host enters again the active state.

### 38.6.3.8 Phase-locked SOFs

To support the Synchronous Endpoints capability, the period of the emitted Start-of-Frame is maintained while the USB connection is not in the active state. This does not apply for the disconnected/connected/reset states. It applies for active/idle/suspend/resume states. The period of Start-of-Frame will be 1ms when the USB connection is in active state and an integer number of milli-seconds across idle/suspend/resume states.

To ensure the Synchronous Endpoints capability, the GCLK\_USB clock must be kept running. If the GCLK\_USB is interrupted, the period of the emitted Start-of-Frame will be erratic.

### 38.6.3.9 Management of Control Pipes

A control transaction is composed of three stages:

- SETUP
- Data (IN or OUT)
- Status (IN or OUT)

The user has to change the pipe token according to each stage using the Pipe Token field in PCFG (PCFG.PTOKEN).

For control pipes only, the token is assigned a specific initial data toggle sequence:

- SETUP: Data0
- IN: Data1
- OUT: Data1

### 38.6.3.10 Management of IN Pipes

IN packets are sent by the USB device controller upon IN request reception from the host. All the received data from the device to the host will be stored in the bank provided the bank is empty. The pipe and its descriptor in RAM must be configured.

The host indicates it is able to receive data from the device by clearing the Bank 0/1 Ready bit in PSTATUS (PSTATUS.BK0/1RDY), which means that the memory for the bank is available for new USB transfer.

The USB will perform IN requests as long as the pipe is not frozen by the user.

The generation of IN requests starts when the pipe is unfrozen (PSTATUS.PFREEZE is set to zero).

When the current bank is full, the Transmit Complete 0/1 bit in PINTFLAG (PINTFLAG.TRCPT0/1) will be set and trigger an interrupt if enabled and the PSTATUS.BK0/1RDY bit will be set.

PINTFLAG.TRCPT0/1 must be cleared by software to acknowledge the interrupt. This is done by writing a one to the PINTFLAG.TRCPT0/1 of the addressed pipe.

The user reads the PCKSIZE.BYTE\_COUNT to know how many bytes should be read.

To free the bank the user must read the IN data from the address ADDR in the pipe descriptor and clear the PKSTATUS.BK0/1RDY bit. When the IN pipe is composed of multiple banks, a successful IN transaction will switch to the next bank. Another IN request will be performed by the host as long as the PSTATUS.BK0/1RDY bit for that bank is set. The PINTFLAG.TRCPT0/1 and PSTATUS.BK0/1RDY will be updated accordingly.

The user can follow the current bank looking at Current Bank bit in PSTATUS (PSTATUS.CURBK) and by looking at Data Toggle for IN pipe bit in PSTATUS (PSTATUS.DTGLIN).

When the pipe is configured as single bank (Pipe Bank bit in PCFG (PCFG.BK) is 0), only PINTFLAG.TRCPT0 and PSTATUS.BK0 are used. When the pipe is configured as dual bank (PCFG.BK is 1), both PINTFLAG.TRCPT0/1 and PSTATUS.BK0/1 are used.

### 38.6.3.11 Management of OUT Pipes

OUT packets are sent by the host. All the data stored in the bank will be sent to the device provided the bank is filled. The pipe and its descriptor in RAM must be configured.

The host can send data to the device by writing to the data bank 0 in single bank or the data bank 0/1 in dual bank.

The generation of OUT packet starts when the pipe is unfrozen (PSTATUS.PFREEZE is zero).

The user writes the OUT data to the data buffer pointer by ADDR in the pipe descriptor and allows the USB to send the data by writing a one to the PSTATUS.BK0/1RDY. This will also cause a switch to the next bank if the OUT pipe is part of a dual bank configuration.

PINTFLAGn.TRCPT0/1 must be cleared before setting PSTATUS.BK0/1RDY to avoid missing an PINTFLAGn.TRCPT0/1 event.

### 38.6.3.12 Alternate Pipe

The user has the possibility to run sequentially several logical pipes on the same physical pipe. It allows addressing of any device endpoint of any attached device on the bus.

Before switching pipe, the user should save the pipe context (Pipe registers and descriptor for pipe n).

After switching pipe, the user should restore the pipe context (Pipe registers and descriptor for pipe n) and in particular PCFG, and PSTATUS.

### 38.6.3.13 Data Flow Error

This error exists only for isochronous and interrupt pipes for both IN and OUT directions. It sets the Transmit Fail bit in PINTFLAG (PINTFLAG.TRFAIL), which triggers an interrupt if the Transmit Fail bit in PINTENCLR/SET(PINTENCLR/SET.TRFAIL) is set. The user must check the Pipe Interrupt Summary register (PINTSMRY) to find out the pipe which triggered the interrupt. Then the user must check the origin of the interrupt's bank by looking at the Pipe Bank Status register (STATUS\_BK) for each bank. If the Error Flow bit in the STATUS\_BK (STATUS\_BK.ERRORFLOW) is set then the user is able to determine the origin of the data flow error. As the user knows that the endpoint is an IN or OUT the error flow can be deduced as OUT underflow or as an IN overflow.

An underflow can occur during an OUT stage if the host attempts to send data from an empty bank. If a new transaction is successful, the relevant bank descriptor STATUS\_BK.ERRORFLOW will be cleared.

An overflow can occur during an IN stage if the device tries to send a packet while the bank is full. Typically this occurs when a CPU is not fast enough. The packet data is not written to the bank and is lost. If a new transaction is successful, the relevant bank descriptor STATUS\_BK.ERRORFLOW will be cleared.

### 38.6.3.14 CRC Error

This error exists only for isochronous IN pipes. It sets the PINTFLAG.TRFAIL, which triggers an interrupt if PINTENCLR/SET.TRFAIL is set. The user must check the PINTSMRY to find out the pipe which triggered the interrupt. Then the user must check the origin of the interrupt's bank by looking at the bank descriptor STATUS\_BK for each bank and if the CRC Error bit in STATUS\_BK (STATUS\_BK.CRCERR) is set then the user is able to determine the origin of the CRC error. A CRC error can occur during the IN



stage if the USB detects a corrupted packet. The IN packet will remain stored in the bank and PINTFLAG.TRCPT0/1 will be set.

### 38.6.3.15 PERR Error

This error exists for all pipes. It sets the PINTFLAG.PERR Interrupt, which triggers an interrupt if PINTFLAG.PERR is set. The user must check the PINTSMRY register to find out the pipe which can cause an interrupt.

A PERR error occurs if one of the error field in the STATUS\_PIPE register in the Host pipe descriptor is set and the Error Count field in STATUS\_PIPE (STATUS\_PIPE.ERCNT) exceeds the maximum allowed number of Pipe error(s) as defined in Pipe Error Max Number field in CTRL\_PIPE (CTRL\_PIPE.PERMAX). Refer to section [38.8.7.7 STATUS\\_PIPE](#) register.

If one of the error field in the STATUS\_PIPE register from the Host Pipe Descriptor is set and the STATUS\_PIPE.ERCNT is less than the CTRL\_PIPE.PERMAX, the STATUS\_PIPE.ERCNT is incremented.

### 38.6.3.16 Link Power Management L1 (LPM-L1) Suspend State Entry and Exit as Host.

An EXTENDED LPM transaction can be transmitted by any enabled pipe. The PCFGn.PTYPE should be set to EXTENDED. Other fields as PCFG.PTOKEN, PCFG.BK and PCKSIZE.SIZE are irrelevant in this configuration. The user should also set the EXTREG.VARIABLE in the descriptor as described in [38.8.7.4 EXTREG](#) register.

When the pipe is configured and enabled, an EXTENDED TOKEN followed by a LPM TOKEN are transmitted. The device responds with a valid HANDSHAKE, corrupted HANDSHAKE or no HANDSHAKE (TIME-OUT).

If the valid HANDSHAKE is an ACK, the host will immediately proceed to L1 SLEEP and the PINTFLAG.TRCT0 is set. The minimum duration of the L1 SLEEP state will be the TL1RetryAndResidency as defined in the reference document "ENGINEERING CHANGE NOTICE, USB 2.0 Link Power Management Addendum". When entering the L1 SLEEP state, the CTRLB.SOFE is cleared, avoiding Start-of-Frame generation.

If the valid HANDSHAKE is a NYET PINTFLAG.TRFAIL is set.

If the valid HANDSHAKE is a STALL the PINTFLAG.STALL is set.

If there is no HANDSHAKE or corrupted HANDSHAKE, the EXTENDED/LPM pair of TOKENS will be transmitted again until reaching the maximum number of retries as defined by the CTRL\_PIPE.PERMAX in the pipe descriptor.

If the last retry returns no valid HANDSHAKE, the PINTFLAGn.PERR is set, and the STATUS\_BK is updated in the pipe descriptor.

All LPM transactions, should they end up with a ACK, a NYET, a STALL or a PERR, will set the PSTATUS.PFREEZE bit, freezing the pipe before a succeeding operation. The user should unfreeze the pipe to start a new LPM transaction.

To exit the L1 STATE, the user initiate a DOWNSTREAM RESUME by setting the bit CTRLB.RESUME or a L1 RESUME by setting the Send L1 Resume bit in CTRLB (CTRLB.L1RESUME). In the case of a L1 RESUME, the K STATE duration is given by the BESL bit field in the EXTREG.VARIABLE field. See [38.8.7.4 EXTREG](#).

When the host is in the L1 SLEEP state after a successful LPM transmitted, the device can initiate an UPSTREAM RESUME. This will set the Upstream Resume Interrupt bit in INTFLAG (INTFLAG.UPRSM). The host should proceed then to a L1 RESUME as described above.

# SAM D5x/E5x Family Data Sheet

## USB – Universal Serial Bus

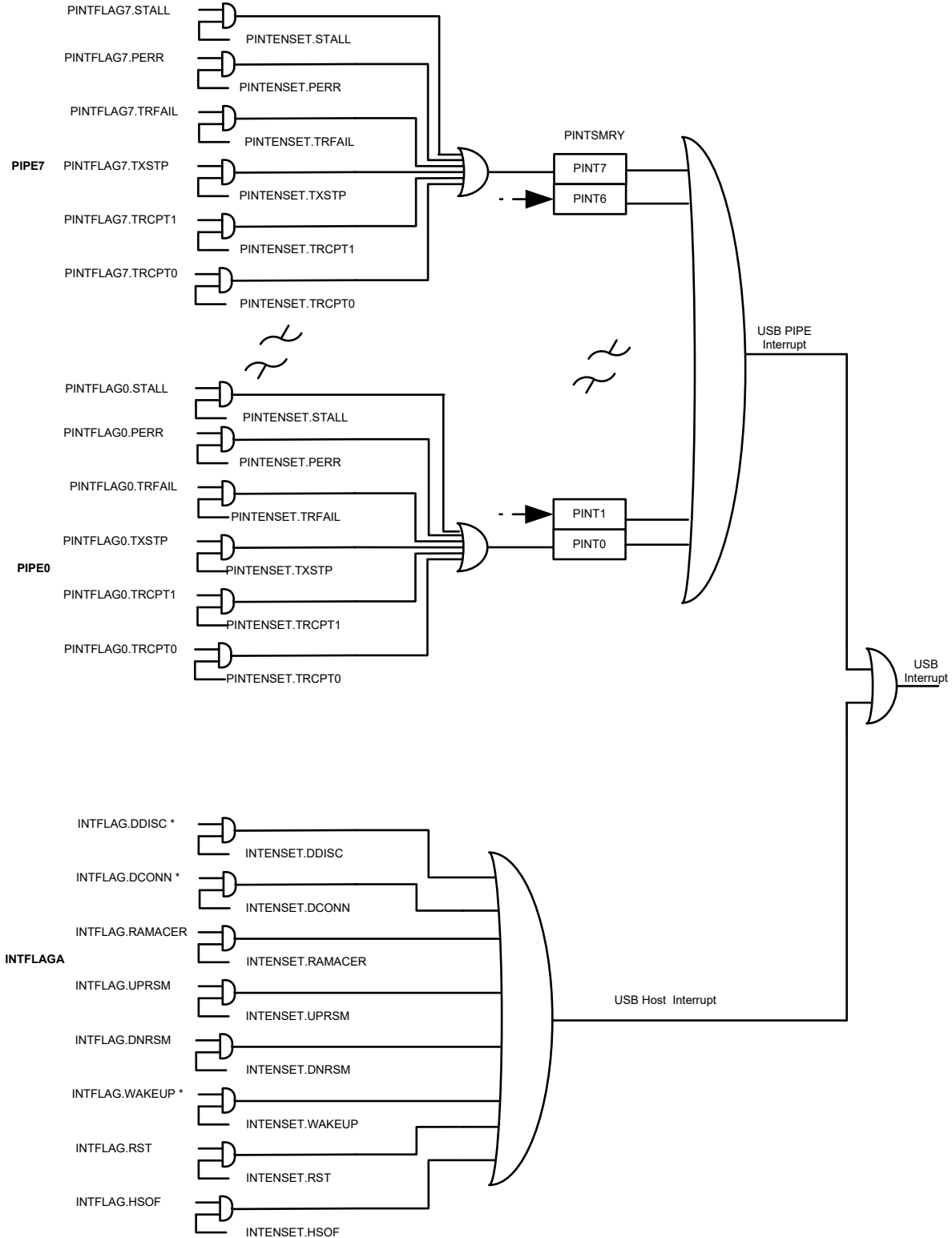
---

---

After resuming from the L1 SLEEP state, the bit CTRLB.SOFE is set, allowing Start-of-Frame generation.

### 38.6.3.17 Host Interrupt

**Figure 38-10. Host Interrupt**



\* Asynchronous interrupt

The WAKEUP is an asynchronous interrupt and can be used to wake-up the device from any sleep mode.

# SAM D5x/E5x Family Data Sheet

## USB – Universal Serial Bus

### 38.7 Register Summary

The register mapping depends on the Operating Mode field in the Control A register (CTRLA.MODE). The register summary is detailed below.

#### 38.7.1 Common Device Summary

Offset	Name	Bit Pos.								
0x00	CTRLA	7:0	MODE					RUNSTBY	ENABLE	SWRST
0x01	Reserved									
0x02	SYNCBUSY	7:0							ENABLE	SWRST
0x03	QOSCTRL	7:0					DQOS[1:0]		CQOS[1:0]	
0x0D	FSMSTATUS	7:0					FSMSTATE[6:0]			
0x24	DESCADD	7:0	DESCADD[7:0]							
0x25		15:8	DESCADD[15:8]							
0x26		23:16	DESCADD[23:16]							
0x27		31:24	DESCADD[31:24]							
0x28	PADCAL	7:0	TRANSN[1:0]				TRANSP[4:0]			
0x29		15:8		TRIM[2:0]				TRANSN[4:2]		

#### 38.7.2 Device Summary

**Table 38-1. General Device Registers**

Offset	Name	Bit Pos.								
0x04	Reserved									
0x05	Reserved									
0x06	Reserved									
0x07	Reserved									
0x08	CTRLB	7:0			NREPLY		SPDCONF[1:0]	UPRSM	DETACH	
0x09		15:8				LPMHDSK[1:0]		GNAK		
0x0A	DADD		ADDEN	DADD[6:0]						
0x0B	Reserved									
0x0C	STATUS	7:0	LINESTATE[1:0]				SPEED[1:0]			
0x0E	Reserved									
0x0F	Reserved									
0x10	FNUM	7:0	FNUM[4:0]							
0x11		15:8	FNCERR	FNUM[10:5]						
0x12	Reserved									
0x14	INTENCLR	7:0	RAMACER	UPRSM	EORSM	WAKEUP	EORST	SOF		SUSPEND
0x15		15:8							LPMSUSP	LPMNYET
0x16	Reserved									
0x17	Reserved									
0x18	INTENSET	7:0	RAMACER	UPRSM	EORSM	WAKEUP	EORST	SOF		SUSPEND
0x19		15:8							LPMSUSP	LPMNYET
0x1A	Reserved									
0x1B	Reserved									

# SAM D5x/E5x Family Data Sheet

## USB – Universal Serial Bus

.....continued

Offset	Name	Bit Pos.								
0x1C	INTFLAG	7:0	RAMACER	UPRSM	EORSM	WAKEUP	EORST	SOF		SUSPEND
0x1D		15:8							LPMSUSP	LPMNYET
0x1E	Reserved									
0x1F	Reserved									
0x20	EPINTSMRY	7:0	EPINT[7:0]							
0x21		15:8	EPINT[15:8]							
0x22	Reserved									
0x23	Reserved									

**Table 38-2. Device Endpoint Register n**

Offset	Name	Bit Pos.									
0x1m0	EPCFGn	7:0		EPTYPE1[1:0]				EPTYPE0[1:0]			
0x1m1	Reserved										
0x1m2	Reserved										
0x1m3	Reserved										
0x1m4	EPSTATUSCLRn	7:0	BK1RDY	BK0RDY	STALLRQ1	STALLRQ0		CURBK	DTGLIN	DTGLOUT	
0x1m5	EPSTATUSSETn	7:0	BK1RDY	BK0RDY	STALLRQ1	STALLRQ0		CURBK	DTGLIN	DTGLOUT	
0x1m6	EPSTATUSn	7:0	BK1RDY	BK0RDY	STALLRQ1	STALLRQ0		CURBK	DTGLIN	DTGLOUT	
0x1m7	EPINTFLAGn	7:0		STALL1	STALL0	RXSTP	TRFAIL1	TRFAIL0	TRCPT1	TRCPT0	
0x1m8	EPINTENCLRn	7:0		STALL1	STALL0	RXSTP	TRFAIL1	TRFAIL0	TRCPT1	TRCPT0	
0x1m9	EPINTENSETn	7:0		STALL1	STALL0	RXSTP	TRFAIL1	TRFAIL0	TRCPT1	TRCPT0	
0x1mA	Reserved										
0x1mB	Reserved										

**Table 38-3. Device Endpoint n Descriptor Bank 0**

Offset 0x n0 + index	Name	Bit Pos.								
0x00	ADDR	7:0	ADD[7:0]							
0x01		15:8	ADD[15:8]							
0x02		23:16	ADD[23:16]							
0x03		31:24	ADD[31:24]							
0x04	PCKSIZE	7:0	BYTE_COUNT[7:0]							
0x05		15:8	MULTI_PACKET_SIZE[1:0]	BYTE_COUNT[13:8]						
0x06		23:16	MULTI_PACKET_SIZE[9:2]							
0x07		31:24	AUTO_ZLP	SIZE[2:0]				MULTI_PACKET_SIZE[13:10]		
0x08	EXTREG	7:0	VARIABLE[3:0]				SUBPID[3:0]			
0x09		15:8	VARIABLE[10:4]							
0x0A	STATUS_BK	7:0							ERRORFLOW	CRCERR
0x0B	Reserved	7:0								
0x0C	Reserved	7:0								
0x0D	Reserved	7:0								
0x0E	Reserved	7:0								
0x0F	Reserved	7:0								

# SAM D5x/E5x Family Data Sheet

## USB – Universal Serial Bus

**Table 38-4. Device Endpoint n Descriptor Bank 1**

Offset 0x n0 + 0x10 + index	Name	Bit Pos.									
0x00	ADDR	7:0	ADD[7:0]								
0x01		15:8	ADD[15:8]								
0x02		23:16	ADD[23:16]								
0x03		31:24	ADD[31:24]								
0x04	PCKSIZE	7:0	BYTE_COUNT[7:0]								
0x05		15:8	MULTI_PACKET_SIZE[1:0]	BYTE_COUNT[13:8]							
0x06		23:16	MULTI_PACKET_SIZE[9:2]								
0x07		31:24	AUTO_ZLP	SIZE[2:0]				MULTI_PACKET_SIZE[13:10]			
0x08	Reserved	7:0									
0x09	Reserved	15:8									
0x0A	STATUS_BK	7:0						ERRORFLOW	CRCERR		
0x0B	Reserved	7:0									
0x0C	Reserved	7:0									
0x0D	Reserved	7:0									
0x0E	Reserved	7:0									
0x0F	Reserved	7:0									

### 38.7.3 Host Summary

**Table 38-5. General Host Registers**

Offset	Name	Bit Pos.									
0x04	Reserved										
0x05	Reserved										
0x06	Reserved										
0x07	Reserved										
0x08	CTRLB	7:0		TSTK	TSTJ		SPDCONF[1:0]		RESUME		
0x09		15:8					L1RESUME	VBUSOK	BUSRESET	SOFE	
0x0A	HISOFC	7:0	FLENCE				FLENC[3:0]				
0x0B	Reserved										
0x0C	STATUS	7:0	LINESTATE[1:0]				SPEED[1:0]				
0x0E	Reserved										
0x0F	Reserved										
0x10	FNUM	7:0	FNUM[4:0]								
0x11		15:8	FNUM[10:5]								
0x12	FLENHIGH	7:0	FLENHIGH[7:0]								
0x14	INTENCLR	7:0	RAMACER	UPRSM	DNRSM	WAKEUP	RST	HSOF			
0x15		15:8							DDISC	DCONN	
0x16	Reserved										
0x17	Reserved										
0x18	INTENSET	7:0	RAMACER	UPRSM	DNRSM	WAKEUP	RST	HSOF			
0x19		15:8							DDISC	DCONN	

# SAM D5x/E5x Family Data Sheet

## USB – Universal Serial Bus

.....continued

Offset	Name	Bit Pos.								
0x1A	Reserved									
0x1B	Reserved									
0x1C	INTFLAG	7:0	RAMACER	UPRSM	DNRSM	WAKEUP	RST	HSOF		
0x1D		15:8							DDISC	DCONN
0x1E	Reserved									
0x1F	Reserved									
0x20	PINTSMRY	7:0	PINT[7:0]							
0x21		15:8	PINT[15:8]							
0x22	Reserved									
0x23										

**Table 38-6. Host Pipe Register n**

Offset	Name	Bit Pos.								
0x1m0	PCFGn	7:0			PTYPE[2:0]			BK	PTOKEN[1:0]	
0x1m1	Reserved									
0x1m2	Reserved									
0x1m3	BINTERVAL	7:0	BINTERVAL[7:0]							
0x1m4	PSTATUSCLRn	7:0	BK1RDY	BK0RDY		PFREEZE		CURBK		DTGL
0x1m5	PSTATUSSETn	7:0	BK1RDY	BK0RDY		PFREEZE		CURBK		DTGL
0x1m6	PSTATUSn	7:0	BK1RDY	BK0RDY		PFREEZE		CURBK		DTGL
0x1m7	PINTFLAGn	7:0			STALL	TXSTP	PERR	TRFAIL	TRCPT1	TRCPT0
0x1m8	PINTENCLRn	7:0			STALL	TXSTP	PERR	TRFAIL	TRCPT1	TRCPT0
0x1m9	PINTENSETn	7:0			STALL	TXSTP	PERR	TRFAIL	TRCPT1	TRCPT0
0x1mA	Reserved									
0x1mB	Reserved									

**Table 38-7. Host Pipe n Descriptor Bank 0**

Offset 0x n0 + index	Name	Bit Pos.								
0x00	ADDR	7:0	ADD[7:0]							
0x01		15:8	ADD[15:8]							
0x02		23:16	ADD[23:16]							
0x03		31:24	ADD[31:24]							
0x04	PCKSIZE	7:0	BYTE_COUNT[7:0]							
0x05		15:8	MULTI_PACKET_SIZE[1:0]	BYTE_COUNT[13:8]						
0x06		23:16	MULTI_PACKET_SIZE[9:2]							
0x07		31:24	AUTO_ZLP	SIZE[2:0]				MULTI_PACKET_SIZE[13:10]		
0x08	EXTREG	7:0	VARIABLE[3:0]				SUBPID[3:0]			
0x09		15:8	VARIABLE[10:4]							
0x0A	STATUS_BK	7:0						ERRORFLOW	CRCERR	
0x0B		15:8								
0x0C	CTRL_PIPE	7:0	PDADDR[6:0]							
0x0D		15:8	PEPMAX[3:0]				PEPNUM[3:0]			

# SAM D5x/E5x Family Data Sheet

## USB – Universal Serial Bus

.....continued

Offset 0x n0 + index	Name	Bit Pos.							
0x0E	STATUS_PIPE	7:0	ERCNT[2:0]		CRC16ER	TOUTER	PIDER	DAPIDER	DTGLER
0x0F		15:8							

**Table 38-8. Host Pipe n Descriptor Bank 1**

Offset 0x n0 +0x10 +index	Name	Bit Pos.							
0x00	ADDR	7:0	ADD[7:0]						
0x01		15:8	ADD[15:8]						
0x02		23:16	ADD[23:16]						
0x03		31:24	ADD[31:24]						
0x04	PCKSIZE	7:0	BYTE_COUNT[7:0]						
0x05		15:8	MULTI_PACKET_SIZE[1:0]	BYTE_COUNT[13:8]					
0x06		23:16	MULTI_PACKET_SIZE[9:2]						
0x07		31:24	AUTO_ZLP	SIZE[2:0]			MULTI_PACKET_SIZE[13:10]		
0x08		7:0							
0x09		15:8							
0x0A	STATUS_BK	7:0						ERRORFLOW	CRCERR
0x0B		15:8							
0x0C		7:0							
0x0D		15:8							
0x0E	STATUS_PIPE	7:0	ERCNT[2:0]		CRC16ER	TOUTER	PIDER	DAPIDER	DTGLER
0x0F		15:8							

### 38.8 Register Description

Registers can be 8, 16, or 32 bits wide. Atomic 8-, 16-, and 32-bit accesses are supported. In addition, the 8-bit quarters and 16-bit halves of a 32-bit register, and the 8-bit halves of a 16-bit register can be accessed directly.

Some registers require synchronization when read and/or written. Synchronization is denoted by the "Read-Synchronized" and/or "Write-Synchronized" property in each individual register description.

Optional write protection by the Peripheral Access Controller (PAC) is denoted by the "PAC Write Protection" property in each individual register description.

Some registers are enable-protected, meaning they can only be written when the module is disabled. Enable protection is denoted by the "Enable-Protected" property in each individual register description.

Refer to the [38.5.8 Register Access Protection, PAC - Peripheral Access Controller](#) and *GCLK Synchronization* for details.

#### Related Links

[27. PAC - Peripheral Access Controller](#)

#### 38.8.1 Communication Device Host Registers



### 38.8.1.1 Control A

**Name:** CTRLA  
**Offset:** 0x00  
**Reset:** 0x00  
**Property:** PAC Write-Protection, Write-Synchronised

Bit	7	6	5	4	3	2	1	0
	MODE					RUNSTDBY	ENABLE	SWRST
Access	R/W					R/W	R/W	R/W
Reset	0					0	0	0

#### Bit 7 – MODE Operating Mode

This bit defines the operating mode of the USB.

Value	Description
0	USB Device mode
1	USB Host mode

#### Bit 2 – RUNSTDBY Run in Standby Mode

This bit is Enable-Protected.

Value	Description
0	USB clock is stopped in standby mode.
1	USB clock is running in standby mode

#### Bit 1 – ENABLE Enable

Due to synchronization there is delay from writing CTRLA.ENABLE until the peripheral is enabled/disabled. The value written to CTRLA.ENABLE will read back immediately and the Synchronization status enable bit in the Synchronization Busy register (SYNCBUSY.ENABLE) will be set. SYNCBUSY.ENABLE will be cleared when the operation is complete.

This bit is Write-Synchronized.

Value	Description
0	The peripheral is disabled or being disabled.
1	The peripheral is enabled or being enabled.

#### Bit 0 – SWRST Software Reset

Writing a zero to this bit has no effect.

Writing a '1' to this bit resets all registers in the USB, to their initial state, and the USB will be disabled.

Writing a '1' to CTRLA.SWRST will always take precedence, meaning that all other writes in the same write-operation will be discarded.

Due to synchronization there is a delay from writing CTRLA.SWRST until the reset is complete.

CTRLA.SWRST and SYNCBUSY.SWRST will both be cleared when the reset is complete.

This bit is Write-Synchronized.

Value	Description
0	There is no reset operation ongoing.
1	The reset operation is ongoing.

### 38.8.1.2 Synchronization Busy

**Name:** SYNCBUSY  
**Offset:** 0x02  
**Reset:** 0x00  
**Property:** -

	7	6	5	4	3	2	1	0
							ENABLE	SWRST
Access							R	R
Reset							0	0

**Bit 1 – ENABLE** Synchronization Enable status bit

This bit is cleared when the synchronization of ENABLE register between the clock domains is complete.  
 This bit is set when the synchronization of ENABLE register between clock domains is started.

**Bit 0 – SWRST** Synchronization Software Reset status bit

This bit is cleared when the synchronization of SWRST register between the clock domains is complete.  
 This bit is set when the synchronization of SWRST register between clock domains is started.

### 38.8.1.3 QOS Control

**Name:** QOSCTRL  
**Offset:** 0x03  
**Reset:** 0x0F  
**Property:** PAC Write-Protection

Bit	7	6	5	4	3	2	1	0
					DQOS[1:0]		CQOS[1:0]	
Access					R/W	R/W	R/W	R/W
Reset					1	1	1	1

**Bits 3:2 – DQOS[1:0]** Data Quality of Service

These bits define the memory priority access during the endpoint or pipe read/write data operation. Refer to *SRAM Quality of Service*.

**Bits 1:0 – CQOS[1:0]** Configuration Quality of Service

These bits define the memory priority access during the endpoint or pipe read/write configuration operation. Refer to *SRAM Quality of Service*.

### 38.8.1.4 Finite State Machine Status

**Name:** FSMSTATUS  
**Offset:** 0x0D  
**Reset:** 0xFFFF  
**Property:** Read only

Bit	7	6	5	4	3	2	1	0
	FSMSTATE[6:0]							
Access		R	R	R	R	R	R	R
Reset		0	0	0	0	0	0	1

#### Bits 6:0 – FSMSTATE[6:0] Fine State Machine Status

These bits indicate the state of the finite state machine of the USB controller.

Value	Name	Description
0x01	OFF (L3)	Corresponds to the powered-off, disconnected, and disabled state.
0x02	ON (L0)	Corresponds to the Idle and Active states.
0x04	SUSPEND (L2)	
0x08	SLEEP (L1)	
0x10	DNRESUME	Down Stream Resume.
0x20	UPRESUME	Up Stream Resume.
0x40	RESET	USB lines Reset.
Others		Reserved

# SAM D5x/E5x Family Data Sheet

## USB – Universal Serial Bus

### 38.8.1.5 Descriptor Address

**Name:** DESCADD  
**Offset:** 0x24  
**Reset:** 0x00000000  
**Property:** PAC Write-Protection

	Bit	31	30	29	28	27	26	25	24
		DESCADD[31:24]							
Access		R/W	R/W	R/W	R/W	R/W	R/W	R/W	R/W
Reset		0	0	0	0	0	0	0	0
	Bit	23	22	21	20	19	18	17	16
		DESCADD[23:16]							
Access		R/W	R/W	R/W	R/W	R/W	R/W	R/W	R/W
Reset		0	0	0	0	0	0	0	0
	Bit	15	14	13	12	11	10	9	8
		DESCADD[15:8]							
Access		R/W	R/W	R/W	R/W	R/W	R/W	R/W	R/W
Reset		0	0	0	0	0	0	0	0
	Bit	7	6	5	4	3	2	1	0
		DESCADD[7:0]							
Access		R/W	R/W	R/W	R/W	R/W	R/W	R/W	R/W
Reset		0	0	0	0	0	0	0	0

**Bits 31:0 – DESCADD[31:0] Descriptor Address Value**

These bits define the base address of the main USB descriptor in RAM. The two least significant bits must be written to zero.

### 38.8.1.6 Pad Calibration

**Name:** PADCAL  
**Offset:** 0x28  
**Reset:** 0x0000  
**Property:** PAC Write-Protection

The Pad Calibration values must be loaded from the NVM Software Calibration Area into the USB Pad Calibration register by software, before enabling the USB, to achieve the specified accuracy. Refer to *NVM Software Calibration Area Mapping* for further details.

Refer to for further details.

	Bit	15	14	13	12	11	10	9	8
			TRIM[2:0]				TRANSN[4:2]		
Access			R/W	R/W	R/W		R/W	R/W	R/W
Reset			0	0	0		0	0	0
	Bit	7	6	5	4	3	2	1	0
		TRANSN[1:0]			TRANSP[4:0]				
Access		R/W	R/W		R/W	R/W	R/W	R/W	R/W
Reset		0	0		0	0	0	0	0

**Bits 14:12 – TRIM[2:0]** Trim bits for DP/DM  
 These bits calibrate the matching of rise/fall of DP/DM.

**Bits 10:6 – TRANSN[4:0]** Trimmable Output Driver Impedance N  
 These bits calibrate the NMOS output impedance of DP/DM drivers.

**Bits 4:0 – TRANSP[4:0]** Trimmable Output Driver Impedance P  
 These bits calibrate the PMOS output impedance of DP/DM drivers.

### 38.8.2 Device Registers - Common

# SAM D5x/E5x Family Data Sheet

## USB – Universal Serial Bus

### 38.8.2.1 Control B

**Name:** CTRLB  
**Offset:** 0x08  
**Reset:** 0x0000  
**Property:** PAC Write-Protection

	Bit	15	14	13	12	11	10	9	8
						LPMHDSK[1:0]		GNAK	
Access						R/W	R/W	R/W	
Reset						0	0	0	
	Bit	7	6	5	4	3	2	1	0
					NREPLY	SPDCONF[1:0]		UPRSM	DETACH
Access					R	R/W	R/W	R/W	R/W
Reset					0	0	0	0	0

#### Bits 11:10 – LPMHDSK[1:0] Link Power Management Handshake

These bits select the Link Power Management Handshake configuration.

Value	Description
0x0	No handshake. LPM is not supported.
0x1	ACK
0x2	NYET
0x3	Reserved

#### Bit 9 – GNAK Global NAK

This bit configures the operating mode of the NAK.

This bit is not synchronized.

Value	Description
0	The handshake packet reports the status of the USB transaction
1	A NAK handshake is answered for each USB transaction regardless of the current endpoint memory bank status

#### Bit 4 – NREPLY No reply excepted SETUP Token

This bit is cleared by hardware when receiving a SETUP packet.

This bit has no effect for any other endpoint but endpoint 0.

Value	Description
0	Disable the “NO_REPLY” feature: Any transaction to endpoint 0 will be handled according to the USB2.0 standard.
1	Enable the “NO_REPLY” feature: Any transaction to endpoint 0 will be ignored except SETUP.

#### Bits 3:2 – SPDCONF[1:0] Speed Configuration

These bits select the speed configuration.

Value	Description
0x0	FS: Full-speed
0x1	LS: Low-speed
0x2	Reserved

# SAM D5x/E5x Family Data Sheet

## USB – Universal Serial Bus

---

---

Value	Description
0x3	Reserved

### Bit 1 – UPRSM Upstream Resume

This bit is cleared when the USB receives a USB reset or once the upstream resume has been sent.

Value	Description
0	Writing a zero to this bit has no effect.
1	Writing a one to this bit will generate an upstream resume to the host for a remote wakeup.

### Bit 0 – DETACH Detach

Value	Description
0	The device is attached to the USB bus so that communications may occur.
1	It is the default value at reset. The internal device pull-ups are disabled, removing the device from the USB bus.



### 38.8.2.2 Device Address

**Name:** DADD  
**Offset:** 0x0A  
**Reset:** 0x00  
**Property:** PAC Write-Protection

Bit	7	6	5	4	3	2	1	0
	ADDEN	DADD[6:0]						
Access	R/W	R/W	R/W	R/W	R/W	R/W	R/W	R/W
Reset	0	0	0	0	0	0	0	0

#### Bit 7 – ADDEN Device Address Enable

This bit is cleared when a USB reset is received.

Value	Description
0	Writing a zero will deactivate the DADD field (USB device address) and return the device to default address 0.
1	Writing a one will activate the DADD field (USB device address).

#### Bits 6:0 – DADD[6:0] Device Address

These bits define the device address. The DADD register is reset when a USB reset is received.

### 38.8.2.3 Status

**Name:** STATUS  
**Offset:** 0x0C  
**Reset:** 0x40  
**Property:** -

Bit	7	6	5	4	3	2	1	0
	LINESTATE[1:0]				SPEED[1:0]			
Access	R	R			R/W	R/W		
Reset	0	1			0	1		

#### Bits 7:6 – LINESTATE[1:0] USB Line State Status

These bits define the current line state DP/DM.

LINESTATE[1:0]	USB Line Status
0x0	SE0/RESET
0x1	FS-J or LS-K State
0x2	FS-K or LS-J State

#### Bits 3:2 – SPEED[1:0] Speed Status

These bits define the current speed used of the device

SPEED[1:0]	SPEED STATUS
0x0	Low-speed mode
0x1	Full-speed mode
0x2	Reserved
0x3	Reserved

### 38.8.2.4 Device Frame Number

**Name:** FNUM  
**Offset:** 0x10  
**Reset:** 0x0000  
**Property:** Read only

Bit	15	14	13	12	11	10	9	8
	FNCERR			FNUM[10:5]				
Access	R/W		R/W	R/W	R/W	R/W	R/W	R/W
Reset	0		0	0	0	0	0	0
Bit	7	6	5	4	3	2	1	0
	FNUM[4:0]					MFNUM[2:0]		
Access	R/W	R/W	R/W	R/W	R/W	R/W	R/W	R/W
Reset	0	0	0	0	0	0	0	0

**Bit 15 – FNCERR** Frame Number CRC Error

This bit is cleared upon receiving a USB reset.

This bit is set when a corrupted frame number (or micro-frame number) is received.

This bit and the SOF (or MSOF) interrupt bit are updated at the same time.

**Bits 13:3 – FNUM[10:0]** Frame Number

These bits are cleared upon receiving a USB reset.

These bits are updated with the frame number information as provided from the last SOF packet even if a corrupted SOF is received.

**Bits 2:0 – MFNUM[2:0]** Micro Frame Number

These bits are cleared upon receiving a USB reset or at the beginning of each Start-of-Frame (SOF interrupt).

These bits are updated with the micro-frame number information as provided from the last MSOF packet even if a corrupted MSOF is received.

### 38.8.2.5 Device Interrupt Enable Clear

**Name:** INTENCLR  
**Offset:** 0x14  
**Reset:** 0x0000  
**Property:** PAC Write-Protection

This register allows the user to disable an interrupt without doing a read-modify-write operation. Changes in this register will also be reflected in the Interrupt Enable Set (INTENSET) register.

	15	14	13	12	11	10	9	8
							LPMSUSP	LPMNYET
Access							R/W	R/W
Reset							0	0
	7	6	5	4	3	2	1	0
	RAMACER	UPRSM	EORSM	WAKEUP	EORST	SOF		SUSPEND
Access	R/W	R/W	R/W	R/W	R/W	R/W		R/W
Reset	0	0	0	0	0	0		0

#### Bit 9 – LPMSUSP Link Power Management Suspend Interrupt Enable

Writing a zero to this bit has no effect.

Writing a one to this bit will clear the Link Power Management Suspend Interrupt Enable bit and disable the corresponding interrupt request.

Value	Description
0	The Link Power Management Suspend interrupt is disabled.
1	The Link Power Management Suspend interrupt is enabled and an interrupt request will be generated when the Link Power Management Suspend interrupt Flag is set.

#### Bit 8 – LPMNYET Link Power Management Not Yet Interrupt Enable

Writing a zero to this bit has no effect.

Writing a one to this bit will clear the Link Power Management Not Yet interrupt Enable bit and disable the corresponding interrupt request.

Value	Description
0	The Link Power Management Not Yet interrupt is disabled.
1	The Link Power Management Not Yet interrupt is enabled and an interrupt request will be generated when the Link Power Management Not Yet interrupt Flag is set.

#### Bit 7 – RAMACER RAM Access Interrupt Enable

Writing a zero to this bit has no effect.

Writing a one to this bit will clear the RAM Access interrupt Enable bit and disable the corresponding interrupt request.

Value	Description
0	The RAM Access interrupt is disabled.
1	The RAM Access interrupt is enabled and an interrupt request will be generated when the RAM Access interrupt Flag is set.

#### Bit 6 – UPRSM Upstream Resume Interrupt Enable

Writing a zero to this bit has no effect.

Writing a one to this bit will clear the Upstream Resume interrupt Enable bit and disable the corresponding interrupt request.

Value	Description
0	The Upstream Resume interrupt is disabled.
1	The Upstream Resume interrupt is enabled and an interrupt request will be generated when the Upstream Resume interrupt Flag is set.

### Bit 5 – EORSM End Of Resume Interrupt Enable

Writing a zero to this bit has no effect.

Writing a one to this bit will clear the End Of Resume interrupt Enable bit and disable the corresponding interrupt request.

Value	Description
0	The End Of Resume interrupt is disabled.
1	The End Of Resume interrupt is enabled and an interrupt request will be generated when the End Of Resume interrupt Flag is set.

### Bit 4 – WAKEUP Wake-Up Interrupt Enable

Writing a zero to this bit has no effect.

Writing a one to this bit will clear the Wake Up interrupt Enable bit and disable the corresponding interrupt request.

Value	Description
0	The Wake Up interrupt is disabled.
1	The Wake Up interrupt is enabled and an interrupt request will be generated when the Wake Up interrupt Flag is set.

### Bit 3 – EORST End of Reset Interrupt Enable

Writing a zero to this bit has no effect.

Writing a one to this bit will clear the End of Reset interrupt Enable bit and disable the corresponding interrupt request.

Value	Description
0	The End of Reset interrupt is disabled.
1	The End of Reset interrupt is enabled and an interrupt request will be generated when the End of Reset interrupt Flag is set.

### Bit 2 – SOF Start-of-Frame Interrupt Enable

Writing a zero to this bit has no effect.

Writing a one to this bit will clear the Start-of-Frame interrupt Enable bit and disable the corresponding interrupt request.

Value	Description
0	The Start-of-Frame interrupt is disabled.
1	The Start-of-Frame interrupt is enabled and an interrupt request will be generated when the Start-of-Frame interrupt Flag is set.

### Bit 0 – SUSPEND Suspend Interrupt Enable

Writing a zero to this bit has no effect.

Writing a one to this bit will clear the Suspend Interrupt Enable bit and disable the corresponding interrupt request.

Value	Description
0	The Suspend interrupt is disabled.

# SAM D5x/E5x Family Data Sheet

## USB – Universal Serial Bus

---

---

Value	Description
1	The Suspend interrupt is enabled and an interrupt request will be generated when the Suspend interrupt Flag is set.

### 38.8.2.6 Device Interrupt Enable Set

**Name:** INTENSET  
**Offset:** 0x18  
**Reset:** 0x0000  
**Property:** PAC Write-Protection

This register allows the user to enable an interrupt without doing a read-modify-write operation. Changes in this register will also be reflected in the Interrupt Enable Clear (INTENCLR) register.

	15	14	13	12	11	10	9	8
							LPMSUSP	LPMNYET
Access							R/W	R/W
Reset							0	0
	7	6	5	4	3	2	1	0
	RAMACER	UPRSM	EORSM	WAKEUP	EORST	SOF		SUSPEND
Access	R/W	R/W	R/W	R/W	R/W	R/W		R/W
Reset	0	0	0	0	0	0		0

**Bit 9 – LPMSUSP** Link Power Management Suspend Interrupt Enable

Writing a zero to this bit has no effect.

Writing a one to this bit will set the Link Power Management Suspend Enable bit and enable the corresponding interrupt request.

Value	Description
0	The Link Power Management Suspend interrupt is disabled.
1	The Link Power Management Suspend interrupt is enabled.

**Bit 8 – LPMNYET** Link Power Management Not Yet Interrupt Enable

Writing a zero to this bit has no effect.

Writing a one to this bit will set the Link Power Management Not Yet interrupt bit and enable the corresponding interrupt request.

Value	Description
0	The Link Power Management Not Yet interrupt is disabled.
1	The Link Power Management Not Yet interrupt is enabled.

**Bit 7 – RAMACER** RAM Access Interrupt Enable

Writing a zero to this bit has no effect.

Writing a one to this bit will set the RAM Access Enable bit and enable the corresponding interrupt request.

Value	Description
0	The RAM Access interrupt is disabled.
1	The RAM Access interrupt is enabled.

**Bit 6 – UPRSM** Upstream Resume Interrupt Enable

Writing a zero to this bit has no effect.

Writing a one to this bit will set the Upstream Resume Enable bit and enable the corresponding interrupt request.

Value	Description
0	The Upstream Resume interrupt is disabled.

Value	Description
1	The Upstream Resume interrupt is enabled.

### Bit 5 – EORSM End Of Resume Interrupt Enable

Writing a zero to this bit has no effect.

Writing a one to this bit will set the End Of Resume interrupt Enable bit and enable the corresponding interrupt request.

Value	Description
0	The End Of Resume interrupt is disabled.
1	The End Of Resume interrupt is enabled.

### Bit 4 – WAKEUP Wake-Up Interrupt Enable

Writing a zero to this bit has no effect.

Writing a one to this bit will set the Wake Up interrupt Enable bit and enable the corresponding interrupt request.

Value	Description
0	The Wake Up interrupt is disabled.
1	The Wake Up interrupt is enabled.

### Bit 3 – EORST End of Reset Interrupt Enable

Writing a zero to this bit has no effect.

Writing a one to this bit will set the End of Reset interrupt Enable bit and enable the corresponding interrupt request.

Value	Description
0	The End of Reset interrupt is disabled.
1	The End of Reset interrupt is enabled.

### Bit 2 – SOF Start-of-Frame Interrupt Enable

Writing a zero to this bit has no effect.

Writing a one to this bit will set the Start-of-Frame interrupt Enable bit and enable the corresponding interrupt request.

Value	Description
0	The Start-of-Frame interrupt is disabled.
1	The Start-of-Frame interrupt is enabled.

### Bit 0 – SUSPEND Suspend Interrupt Enable

Writing a zero to this bit has no effect.

Writing a one to this bit will set the Suspend interrupt Enable bit and enable the corresponding interrupt request.

Value	Description
0	The Suspend interrupt is disabled.
1	The Suspend interrupt is enabled.



### 38.8.2.7 Device Interrupt Flag Status and Clear

**Name:** INTFLAG  
**Offset:** 0x01C  
**Reset:** 0x0000  
**Property:** -

	Bit	15	14	13	12	11	10	9	8
								LPMSUSP	LPMNYET
Access								R/W	R/W
Reset								0	0
	Bit	7	6	5	4	3	2	1	0
		RAMACER	UPRSM	EORSM	WAKEUP	EORST	SOF		SUSPEND
Access		R/W	R/W	R/W	R/W	R/W	R/W		R/W
Reset		0	0	0	0	0	0		0

**Bit 9 – LPMSUSP** Link Power Management Suspend Interrupt Flag

This flag is cleared by writing a one to the flag.

This flag is set when the USB module acknowledge a Link Power Management Transaction (ACK handshake) and has entered the Suspended state and will generate an interrupt if INTENCLR/SET.LPMSUSP is one.

Writing a zero to this bit has no effect.

Writing a one to this bit clears the LPMSUSP Interrupt Flag.

**Bit 8 – LPMNYET** Link Power Management Not Yet Interrupt Flag

This flag is cleared by writing a one to the flag.

This flag is set when the USB module acknowledges a Link Power Management Transaction (handshake is NYET) and will generate an interrupt if INTENCLR/SET.LPMNYET is one.

Writing a zero to this bit has no effect.

Writing a one to this bit clears the LPMNYET Interrupt Flag.

**Bit 7 – RAMACER** RAM Access Interrupt Flag

This flag is cleared by writing a one to the flag.

This flag is set when a RAM access underflow error occurs during IN data stage. This bit will generate an interrupt if INTENCLR/SET.RAMACER is one.

Writing a zero to this bit has no effect.

**Bit 6 – UPRSM** Upstream Resume Interrupt Flag

This flag is cleared by writing a one to the flag.

This flag is set when the USB sends a resume signal called “Upstream Resume” and will generate an interrupt if INTENCLR/SET.UPRSM is one.

Writing a zero to this bit has no effect.

**Bit 5 – EORSM** End Of Resume Interrupt Flag

This flag is cleared by writing a one to the flag.

This flag is set when the USB detects a valid “End of Resume” signal initiated by the host and will generate an interrupt if INTENCLR/SET.EORSM is one.

Writing a zero to this bit has no effect.

**Bit 4 – WAKEUP** Wake Up Interrupt Flag

This flag is cleared by writing a one to the flag.

This flag is set when the USB is reactivated by a filtered non-idle signal from the lines and will generate an interrupt if INTENCLR/SET.WAKEUP is one.

Writing a zero to this bit has no effect.

**Bit 3 – EORST** End of Reset Interrupt Flag

This flag is cleared by writing a one to the flag.

This flag is set when a USB “End of Reset” has been detected and will generate an interrupt if INTENCLR/SET.EORST is one.

Writing a zero to this bit has no effect.

**Bit 2 – SOF** Start-of-Frame Interrupt Flag

This flag is cleared by writing a one to the flag.

This flag is set when a USB “Start-of-Frame” has been detected (every 1 ms) and will generate an interrupt if INTENCLR/SET.SOF is one.

The FNUM is updated. In High Speed mode, the MFNUM register is cleared.

Writing a zero to this bit has no effect.

**Bit 0 – SUSPEND** Suspend Interrupt Flag

This flag is cleared by writing a one to the flag.

This flag is set when a USB “Suspend” idle state has been detected for 3 frame periods (J state for 3 ms) and will generate an interrupt if INTENCLR/SET.SUSPEND is one.

Writing a zero to this bit has no effect.

### 38.8.2.8 Endpoint Interrupt Summary

**Name:** EPINTSMRY  
**Offset:** 0x20  
**Reset:** 0x0000  
**Property:** -

	Bit	15	14	13	12	11	10	9	8
		EPINT[15:8]							
Access		R	R	R	R	R	R	R	R
Reset		0	0	0	0	0	0	0	0
	Bit	7	6	5	4	3	2	1	0
		EPINT[7:0]							
Access		R	R	R	R	R	R	R	R
Reset		0	0	0	0	0	0	0	0

**Bits 15:0 – EPINT[15:0] EndPoint Interrupt**

The flag EPINT[n] is set when an interrupt is triggered by the EndPoint n. See [38.8.3.5 EPINTFLAGn](#) register in the device EndPoint section.

This bit will be cleared when no interrupts are pending for EndPoint n.

### 38.8.3 Device Registers - Endpoint

### 38.8.3.1 Device Endpoint Configuration register n

**Name:** EPCFGn  
**Offset:** 0x100 + (n x 0x20)  
**Reset:** 0x00  
**Property:** PAC Write-Protection

Bit	7	6	5	4	3	2	1	0
	EPTYPE1[2:0]				EPTYPE0[2:0]			
Access		R/W	R/W	R/W		R/W	R/W	R/W
Reset		0	0	0		0	0	0

#### Bits 6:4 – EPTYPE1[2:0] Endpoint Type for IN direction

These bits contains the endpoint type for IN direction.

Upon receiving a USB reset EPCFGn.EPTYPE1 is cleared except for endpoint 0 which is unchanged.

Value	Description
0x0	Bank1 is disabled.
0x1	Bank1 is enabled and configured as Control IN.
0x2	Bank1 is enabled and configured as Isochronous IN.
0x3	Bank1 is enabled and configured as Bulk IN.
0x4	Bank1 is enabled and configured as Interrupt IN.
0x5	Bank1 is enabled and configured as Dual-Bank OUT (Endpoint type is the same as the one defined in EPTYPE0)
0x6–0x7	Reserved

#### Bits 2:0 – EPTYPE0[2:0] Endpoint Type for OUT direction

These bits contains the endpoint type for OUT direction.

Upon receiving a USB reset EPCFGn.EPTYPE0 is cleared except for endpoint 0 which is unchanged.

Value	Description
0x0	Bank0 is disabled.
0x1	Bank0 is enabled and configured as Control SETUP / Control OUT.
0x2	Bank0 is enabled and configured as Isochronous OUT.
0x3	Bank0 is enabled and configured as Bulk OUT.
0x4	Bank0 is enabled and configured as Interrupt OUT.
0x5	Bank0 is enabled and configured as Dual Bank IN (Endpoint type is the same as the one defined in EPTYPE1)
0x6–0x7	Reserved

### 38.8.3.2 EndPoint Status Clear n

**Name:** EPSTATUSCLRn  
**Offset:** 0x104 + (n \* 0x20)  
**Reset:** 0x00  
**Property:** PAC Write-Protection

Bit	7	6	5	4	3	2	1	0
	BK1RDY	BK0RDY	STALLRQ1	STALLRQ0		CURBK	DTGLIN	DTGLOUT
Access	W	W	W	W		W	W	W
Reset	0	0	0	0		0	0	0

**Bit 7 – BK1RDY** Bank 1 Ready Clear  
 Writing a zero to this bit has no effect.  
 Writing a one to this bit will clear EPSTATUS.BK1RDY bit.

**Bit 6 – BK0RDY** Bank 0 Ready Clear  
 Writing a zero to this bit has no effect.  
 Writing a one to this bit will clear EPSTATUS.BK0RDY bit.

**Bit 5 – STALLRQ1** STALL bank 1 Request Clear  
 Writing a zero to this bit has no effect.  
 Writing a one to this bit will clear EPSTATUS.STALLRQ1 bit.

**Bit 4 – STALLRQ0** STALL bank 0 Request Clear  
 Writing a zero to this bit has no effect.  
 Writing a one to this bit will clear EPSTATUS.STALLRQ0 bit.

**Bit 2 – CURBK** Current Bank Clear  
 Writing a zero to this bit has no effect.  
 Writing a one to this bit will clear EPSTATUS.CURBK bit.

**Bit 1 – DTGLIN** Data Toggle IN Clear  
 Writing a zero to this bit has no effect.  
 Writing a one to this bit will clear EPSTATUS.DTGLIN bit.

**Bit 0 – DTGLOUT** Data Toggle OUT Clear  
 Writing a zero to this bit has no effect.  
 Writing a one to this bit will clear the EPSTATUS.DTGLOUT bit.

### 38.8.3.3 EndPoint Status Set n

**Name:** EPSTATUSSETn  
**Offset:** 0x105 + (n x 0x20)  
**Reset:** 0x00  
**Property:** PAC Write-Protection

	7	6	5	4	3	2	1	0
Bit	BK1RDY	BK0RDY	STALLRQ1	STALLRQ0		CURBK	DTGLIN	DTGLOUT
Access	W	W	W	W		W	W	W
Reset	0	0	0	0		0	0	0

**Bit 7 – BK1RDY** Bank 1 Ready Set  
 Writing a zero to this bit has no effect.  
 Writing a one to this bit will set EPSTATUS.BK1RDY bit.

**Bit 6 – BK0RDY** Bank 0 Ready Set  
 Writing a zero to this bit has no effect.  
 Writing a one to this bit will set EPSTATUS.BK0RDY bit.

**Bit 5 – STALLRQ1** STALL Request bank 1 Set  
 Writing a zero to this bit has no effect.  
 Writing a one to this bit will set EPSTATUS.STALLRQ1 bit.

**Bit 4 – STALLRQ0** STALL Request bank 0 Set  
 Writing a zero to this bit has no effect.  
 Writing a one to this bit will set EPSTATUS.STALLRQ0 bit.

**Bit 2 – CURBK** Current Bank Set  
 Writing a zero to this bit has no effect.  
 Writing a one to this bit will set EPSTATUS.CURBK bit.

**Bit 1 – DTGLIN** Data Toggle IN Set  
 Writing a zero to this bit has no effect.  
 Writing a one to this bit will set EPSTATUS.DTGLIN bit.

**Bit 0 – DTGLOUT** Data Toggle OUT Set  
 Writing a zero to this bit has no effect.  
 Writing a one to this bit will set the EPSTATUS.DTGLOUT bit.

# SAM D5x/E5x Family Data Sheet

## USB – Universal Serial Bus

### 38.8.3.4 EndPoint Status n

**Name:** EPSTATUSn  
**Offset:** 0x106 + (n x 0x20)  
**Reset:** 0x00  
**Property:** PAC Write-Protection

Bit	7	6	5	4	3	2	1	0
	BK1RDY	BK0RDY		STALLRQ		CURBK	DTGLIN	DTGLOUT
Access	R	R		R		R	R	R
Reset	0	0		2		0	0	0

#### Bit 7 – BK1RDY Bank 1 is ready

For Control/OUT direction Endpoints, the bank is empty.

Writing a one to the bit EPSTATUSCLR.BK1RDY will clear this bit.

Writing a one to the bit EPSTATUSSET.BK1RDY will set this bit.

Value	Description
0	The bank number 1 is not ready : For IN direction Endpoints, the bank is not yet filled in.
1	The bank number 1 is ready: For IN direction Endpoints, the bank is filled in. For Control/OUT direction Endpoints, the bank is full.

#### Bit 6 – BK0RDY Bank 0 is ready

Writing a one to the bit EPSTATUSCLR.BK0RDY will clear this bit.

Writing a one to the bit EPSTATUSSET.BK0RDY will set this bit.

Value	Description
0	The bank number 0 is not ready : For IN direction Endpoints, the bank is not yet filled in. For Control/OUT direction Endpoints, the bank is empty.
1	The bank number 0 is ready: For IN direction Endpoints, the bank is filled in. For Control/OUT direction Endpoints, the bank is full.

#### Bit 4 – STALLRQ STALL bank x request

Writing a zero to the bit EPSTATUSCLR.STALLRQ will clear this bit.

Writing a one to the bit EPSTATUSSET.STALLRQ will set this bit.

This bit is cleared by hardware when receiving a SETUP packet.

Value	Description
0	Disable STALLRQx feature.
1	Enable STALLRQx feature: a STALL handshake will be sent to the host in regards to bank x.

#### Bit 2 – CURBK Current Bank

Writing a zero to the bit EPSTATUSCLR.CURBK will clear this bit.

Writing a one to the bit EPSTATUSSET.CURBK will set this bit.

Value	Description
0	The bank0 is the bank that will be used in the next single/multi USB packet.
1	The bank1 is the bank that will be used in the next single/multi USB packet.

#### Bit 1 – DTGLIN Data Toggle IN Sequence

Writing a zero to the bit EPSTATUSCLR.DTGLINCLR will clear this bit.

Writing a one to the bit EPSTATUSSET.DTGLINSET will set this bit.

# SAM D5x/E5x Family Data Sheet

## USB – Universal Serial Bus

---

---

Value	Description
0	The PID of the next expected IN transaction will be zero: data 0.
1	The PID of the next expected IN transaction will be one: data 1.

### Bit 0 – DTGLOUT Data Toggle OUT Sequence

Writing a zero to the bit EPSTATUSCLR.DTGLOUTCLR will clear this bit.

Writing a one to the bit EPSTATUSSET.DTGLOUTSET will set this bit.

Value	Description
0	The PID of the next expected OUT transaction will be zero: data 0.
1	The PID of the next expected OUR transaction will be one: data 1.



### 38.8.3.5 Device EndPoint Interrupt Flag n

**Name:** EPINTFLAGn  
**Offset:** 0x107 + (n x 0x20)  
**Reset:** 0x00  
**Property:** -

	7	6	5	4	3	2	1	0
Access			R/W	R/W		R/W		R/W
Reset			0	0		0		0

**Bit 5 – STALL** Transmit Stall x Interrupt Flag

This flag is cleared by writing a one to the flag.

This flag is set when a Transmit Stall occurs and will generate an interrupt if EPINTENCLR/SET.STALL is one.

EPINTFLAG.STALL is set for a single bank OUT endpoint or double bank IN/OUT endpoint when current bank is "0".

Writing a zero to this bit has no effect.

Writing a one to this bit clears the STALL Interrupt Flag.

**Bit 4 – RXSTP** Received Setup Interrupt Flag

This flag is cleared by writing a one to the flag.

This flag is set when a Received Setup occurs and will generate an interrupt if EPINTENCLR/SET.RXSTP is one.

Writing a zero to this bit has no effect.

Writing a one to this bit clears the RXSTP Interrupt Flag.

**Bit 2 – TRFAIL** Transfer Fail x Interrupt Flag

This flag is cleared by writing a one to the flag.

This flag is set when a transfer fail occurs and will generate an interrupt if EPINTENCLR/SET.TRFAIL is one.

EPINTFLAG.TRFAIL is set for a single bank OUT endpoint or double bank IN/OUT endpoint when current bank is "0".

Writing a zero to this bit has no effect.

Writing a one to this bit clears the TRFAIL Interrupt Flag.

**Bit 0 – TRCPT** Transfer Complete x interrupt Flag

This flag is cleared by writing a one to the flag.

This flag is set when a Transfer complete occurs and will generate an interrupt if EPINTENCLR/SET.TRCPT is one. EPINTFLAG.TRCPT is set for a single bank OUT endpoint or double bank IN/OUT endpoint when current bank is "0".

Writing a zero to this bit has no effect.

Writing a one to this bit clears the TRCPT0 Interrupt Flag.

### 38.8.3.6 Device EndPoint Interrupt Enable n

**Name:** EPINTENCLRn  
**Offset:** 0x108 + (n x 0x20)  
**Reset:** 0x00  
**Property:** PAC Write-Protection

This register allows the user to enable an interrupt without doing a read-modify-write operation. Changes in this register will also be reflected in the Endpoint Interrupt Enable Set (EPINTENSET) register.

	7	6	5	4	3	2	1	0
			STALL	RXSTP		TRFAIL		TRCPT
Access			R/W	R/W		R/W		R/W
Reset			0	0		0		0

#### Bit 5 – STALL Transmit STALL x Interrupt Enable

Writing a zero to this bit has no effect.

Writing a one to this bit will clear the Transmit Stall x Interrupt Enable bit and disable the corresponding interrupt request.

Value	Description
0	The Transmit Stall x interrupt is disabled.
1	The Transmit Stall x interrupt is enabled and an interrupt request will be generated when the Transmit Stall x Interrupt Flag is set.

#### Bit 4 – RXSTP Received Setup Interrupt Enable

Writing a zero to this bit has no effect.

Writing a one to this bit will clear the Received Setup Interrupt Enable bit and disable the corresponding interrupt request.

Value	Description
0	The Received Setup interrupt is disabled.
1	The Received Setup interrupt is enabled and an interrupt request will be generated when the Received Setup Interrupt Flag is set.

#### Bit 2 – TRFAIL Transfer Fail x Interrupt Enable

The user should look into the descriptor table status located in ram to be informed about the error condition : ERRORFLOW, CRC.

Writing a zero to this bit has no effect.

Writing a one to this bit will clear the Transfer Fail x Interrupt Enable bit and disable the corresponding interrupt request.

Value	Description
0	The Transfer Fail bank x interrupt is disabled.
1	The Transfer Fail bank x interrupt is enabled and an interrupt request will be generated when the Transfer Fail x Interrupt Flag is set.

#### Bit 0 – TRCPT Transfer Complete x interrupt Enable

Writing a zero to this bit has no effect.

Writing a one to this bit will clear the Transfer Complete x interrupt Enable bit and disable the corresponding interrupt request.

Value	Description
0	The Transfer Complete bank x interrupt is disabled.

# SAM D5x/E5x Family Data Sheet

## USB – Universal Serial Bus

---

---

Value	Description
1	The Transfer Complete bank x interrupt is enabled and an interrupt request will be generated when the Transfer Complete x Interrupt Flag is set.

### 38.8.3.7 Device Interrupt EndPoint Set n

**Name:** EPINTENSETn  
**Offset:** 0x109 + (n x 0x20)  
**Reset:** 0x0000  
**Property:** PAC Write-Protection

This register allows the user to enable an interrupt without doing a read-modify-write operation. Changes in this register will also be reflected in the Endpoint Interrupt Enable Set (EPINTENCLR) register. This register is cleared by USB reset or when EPEN[n] is zero.

	7	6	5	4	3	2	1	0
			STALL	RXSTP		TRFAIL		TRCPT
Access			R/W	R/W		R/W		R/W
Reset			0	0		0		0

#### Bit 5 – STALL Transmit Stall x Interrupt Enable

Writing a zero to this bit has no effect.

Writing a one to this bit will enable the Transmit bank x Stall interrupt.

Value	Description
0	The Transmit Stall x interrupt is disabled.
1	The Transmit Stall x interrupt is enabled.

#### Bit 4 – RXSTP Received Setup Interrupt Enable

Writing a zero to this bit has no effect.

Writing a one to this bit will enable the Received Setup interrupt.

Value	Description
0	The Received Setup interrupt is disabled.
1	The Received Setup interrupt is enabled.

#### Bit 2 – TRFAIL Transfer Fail bank x Interrupt Enable

Writing a zero to this bit has no effect.

Writing a one to this bit will enable the Transfer Fail interrupt.

Value	Description
0	The Transfer Fail interrupt is disabled.
1	The Transfer Fail interrupt is enabled.

#### Bit 0 – TRCPT Transfer Complete bank x interrupt Enable

Writing a zero to this bit has no effect.

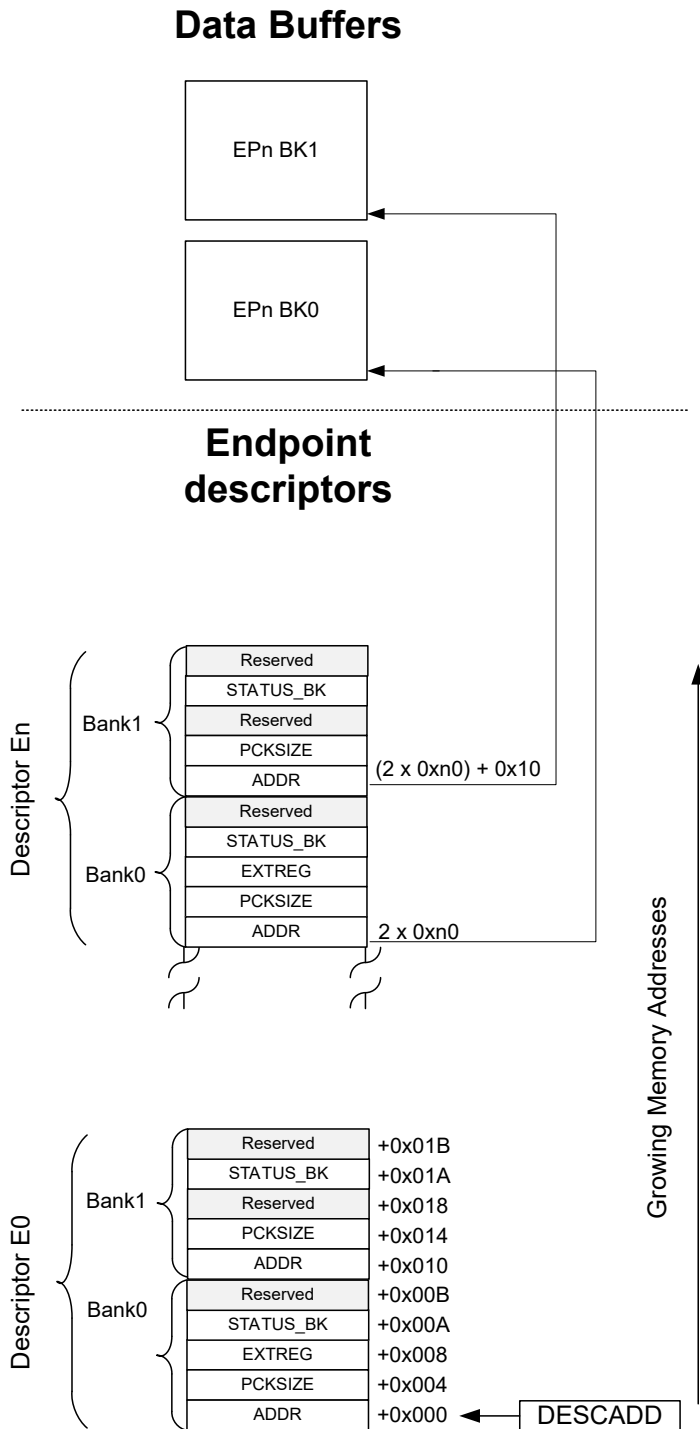
Writing a one to this bit will enable the Transfer Complete x interrupt.

#### 0.2.4 Device Registers - Endpoint RAM

Value	Description
0	The Transfer Complete bank x interrupt is disabled.
1	The Transfer Complete bank x interrupt is enabled.

### 38.8.4 Device Registers - Endpoint RAM

#### 38.8.4.1 Endpoint Descriptor Structure



# SAM D5x/E5x Family Data Sheet

## USB – Universal Serial Bus

### 38.8.4.2 Address of Data Buffer

**Name:** ADDR  
**Offset:** 0x00 & 0x10  
**Reset:** 0xxxxxxx  
**Property:** NA

Bit	31	30	29	28	27	26	25	24
ADDR[31:24]								
Access	R/W	R/W	R/W	R/W	R/W	R/W	R/W	R/W
Reset	x	x	x	x	x	x	x	x
Bit	23	22	21	20	19	18	17	16
ADDR[23:16]								
Access	R/W	R/W	R/W	R/W	R/W	R/W	R/W	R/W
Reset	x	x	x	x	x	x	x	x
Bit	15	14	13	12	11	10	9	8
ADDR[15:8]								
Access	R/W	R/W	R/W	R/W	R/W	R/W	R/W	R/W
Reset	x	x	x	x	x	x	x	x
Bit	7	6	5	4	3	2	1	0
ADDR[7:0]								
Access	R/W	R/W	R/W	R/W	R/W	R/W	R/W	R/W
Reset	x	x	x	x	x	x	x	x

**Bits 31:0 – ADDR[31:0]** Data Pointer Address Value

These bits define the data pointer address as an absolute word address in RAM. The two least significant bits must be zero to ensure the start address is 32-bit aligned.

# SAM D5x/E5x Family Data Sheet

## USB – Universal Serial Bus

### 38.8.4.3 Packet Size

**Name:** PCKSIZE  
**Offset:** 0x04 & 0x14  
**Reset:** 0xxxxxxxx  
**Property:** NA

	Bit	31	30	29	28	27	26	25	24
		AUTO_ZLP		SIZE[2:0]			MULTI_PACKET_SIZE[13:10]		
Access		R/W	R/W	R/W	R/W	R/W	R/W	R/W	R/W
Reset		x	0	0	x	0	0	0	0
	Bit	23	22	21	20	19	18	17	16
		MULTI_PACKET_SIZE[9:2]							
Access		R/W	R/W	R/W	R/W	R/W	R/W	R/W	R/W
Reset		0	0	0	0	0	0	0	0
	Bit	15	14	13	12	11	10	9	8
		MULTI_PACKET_SIZE[1:0]			BYTE_COUNT[13:8]				
Access		R/W	R/W	R/W	R/W	R/W	R/W	R/W	R/W
Reset		0	x	0	0	0	0	0	0
	Bit	7	6	5	4	3	2	1	0
		BYTE_COUNT[7:0]							
Access		R/W	R/W	R/W	R/W	R/W	R/W	R/W	R/W
Reset		0	0	0	0	0	0	0	x

#### Bit 31 – AUTO\_ZLP Automatic Zero Length Packet

This bit defines the automatic Zero Length Packet mode of the endpoint.

When enabled, the USB module will manage the ZLP handshake by hardware. This bit is for IN endpoints only. When disabled the handshake should be managed by firmware.

Value	Description
0	Automatic Zero Length Packet is disabled.
1	Automatic Zero Length Packet is enabled.

#### Bits 30:28 – SIZE[2:0] Endpoint size

These bits contains the maximum packet size of the endpoint.

Value	Description
0x0	8 Byte
0x1	16 Byte
0x2	32 Byte
0x3	64 Byte
0x4	128 Byte <sup>(1)</sup>
0x5	256 Byte <sup>(1)</sup>

.....continued

Value	Description
0x6	512 Byte <sup>(1)</sup>
0x7	1023 Byte <sup>(1)</sup>

(1) for Isochronous endpoints only.

**Bits 27:14 – MULTI\_PACKET\_SIZE[13:0]** Multiple Packet Size

These bits define the 14-bit value that is used for multi-packet transfers.

For IN endpoints, MULTI\_PACKET\_SIZE holds the total number of bytes sent. MULTI\_PACKET\_SIZE should be written to zero when setting up a new transfer.

For OUT endpoints, MULTI\_PACKET\_SIZE holds the total data size for the complete transfer. This value must be a multiple of the maximum packet size.

**Bits 13:0 – BYTE\_COUNT[13:0]** Byte Count

These bits define the 14-bit value that is used for the byte count.

For IN endpoints, BYTE\_COUNT holds the number of bytes to be sent in the next IN transaction.

For OUT endpoint or SETUP endpoints, BYTE\_COUNT holds the number of bytes received upon the last OUT or SETUP transaction.



# SAM D5x/E5x Family Data Sheet

## USB – Universal Serial Bus

### 38.8.4.4 Extended Register

**Name:** EXTREG  
**Offset:** 0x08  
**Reset:** 0xxxxxxx  
**Property:** NA

Bit	15	14	13	12	11	10	9	8
	VARIABLE[10:4]							
Access		R/W	R/W	R/W	R/W	R/W	R/W	R/W
Reset		0	0	0	0	0	0	0
Bit	7	6	5	4	3	2	1	0
	VARIABLE[3:0]				SUBPID[3:0]			
Access	R/W	R/W	R/W	R/W	R/W	R/W	R/W	R/W
Reset	0	0	0	x	0	0	0	x

#### Bits 14:4 – VARIABLE[10:0] Variable field send with extended token

These bits define the VARIABLE field of a received extended token. These bits are updated when the USB has answered by an handshake token ACK to a LPM transaction. See Section 2.1.1 Protocol Extension Token in the reference document “ENGINEERING CHANGE NOTICE, USB 2.0 Link Power Management Addendum”.

To support the USB2.0 Link Power Management addition the VARIABLE field should be read as described below.

VARIABLES	Description
VARIABLE[3:0]	bLinkState (1)
VARIABLE[7:4]	BESL (2)
VARIABLE[8]	bRemoteWake (1)
VARIABLE[10:9]	Reserved

1. For a definition of LPM Token bRemoteWake and bLinkState fields, refer to "Table 2-3 in the reference document ENGINEERING CHANGE NOTICE, USB 2.0 Link Power Management Addendum".
2. For a definition of LPM Token BESL field, refer to "Table 2-3 in the reference document ENGINEERING CHANGE NOTICE, USB 2.0 Link Power Management Addendum" and "Table X-X1 in Errata for ECN USB 2.0 Link Power Management".

#### Bits 3:0 – SUBPID[3:0] SUBPID field send with extended token

These bits define the SUBPID field of a received extended token. These bits are updated when the USB has answered by an handshake token ACK to a LPM transaction. See Section 2.1.1 Protocol Extension Token in the reference document “ENGINEERING CHANGE NOTICE, USB 2.0 Link Power Management Addendum”.

# SAM D5x/E5x Family Data Sheet

## USB – Universal Serial Bus

### 38.8.4.5 Device Status Bank

**Name:** STATUS\_BK  
**Offset:** 0x0A & 0x1A  
**Reset:** 0xxxxxxx  
**Property:** NA

	7	6	5	4	3	2	1	0
							ERRORFLOW	CRCERR
Access							R/W	R/W
Reset							x	x

#### Bit 1 – ERRORFLOW Error Flow Status

This bit defines the Error Flow Status.

This bit is set when a Error Flow has been detected during transfer from/towards this bank.

For OUT transfer, a NAK handshake has been sent.

For Isochronous OUT transfer, an overrun condition has occurred.

For IN transfer, this bit is not valid. EPSTATUS.TRFAIL0 and EPSTATUS.TRFAIL1 should reflect the flow errors.

Value	Description
0	No Error Flow detected.
1	A Error Flow has been detected.

#### Bit 0 – CRCERR CRC Error

This bit defines the CRC Error Status.

This bit is set when a CRC error has been detected in an isochronous OUT endpoint bank.

#### 0.2.5 Host Registers - Common

Value	Description
0	No CRC Error.
1	CRC Error detected.

### 38.8.5 Host Registers - Common

# SAM D5x/E5x Family Data Sheet

## USB – Universal Serial Bus

### 38.8.5.1 Control B

**Name:** CTRLB  
**Offset:** 0x08  
**Reset:** 0x0000  
**Property:** PAC Write-Protection

Bit	15	14	13	12	11	10	9	8
					L1RESUME	VBUSOK	BUSRESET	SOFE
Access					R/W	R/W	R/W	R/W
Reset					0	0	0	0

Bit	7	6	5	4	3	2	1	0
					SPDCONF[1:0]		RESUME	
Access					R/W	R/W	R/W	
Reset					0	0	0	

#### Bit 11 – L1RESUME Send USB L1 Resume

Writing 0 to this bit has no effect.

1: Generates a USB L1 Resume on the USB bus. This bit should only be set when the Start-of-Frame generation is enabled (SOFE bit set). The duration of the USB L1 Resume is defined by the EXTREG.VARIABLE[7:4] bits field also known as BESL (See LPM ECN). See also [38.8.7.4 EXTREG Register](#).

This bit is cleared when the USB L1 Resume has been sent or when a USB reset is requested.

#### Bit 10 – VBUSOK VBUS is OK

This notifies the USB HOST that USB operations can be started. When this bit is zero and even if the USB HOST is configured and enabled, HOST operation is halted. Setting this bit will allow HOST operation when the USB is configured and enabled.

Value	Description
0	The USB module is notified that the VBUS on the USB line is not powered.
1	The USB module is notified that the VBUS on the USB line is powered.

#### Bit 9 – BUSRESET Send USB Reset

Value	Description
0	Reset generation is disabled. It is written to zero when the USB reset is completed or when a device disconnection is detected. Writing zero has no effect.
1	Generates a USB Reset on the USB bus.

#### Bit 8 – SOFE Start-of-Frame Generation Enable

Value	Description
0	The SOF generation is disabled and the USB bus is in suspend state.
1	Generates SOF on the USB bus in full speed and keep it alive in low speed mode. This bit is automatically set at the end of a USB reset (INTFLAG.RST) or at the end of a downstream resume (INTFLAG.DNRSM) or at the end of L1 resume.

#### Bits 3:2 – SPDCONF[1:0] Speed Configuration for Host

These bits select the host speed configuration as shown below

# SAM D5x/E5x Family Data Sheet

## USB – Universal Serial Bus

Value	Description
0x0	Low and Full Speed capable
0x1	Reserved
0x2	Reserved
0x3	Reserved

### **Bit 1 – RESUME** Send USB Resume

Writing 0 to this bit has no effect.

1: Generates a USB Resume on the USB bus.

This bit is cleared when the USB Resume has been sent or when a USB reset is requested.

### 38.8.5.2 Host Start-of-Frame Control

**Name:** HSOFC  
**Offset:** 0x0A  
**Reset:** 0x00  
**Property:** PAC Write-Protection

During a very short period just before transmitting a Start-of-Frame, this register is locked. Thus, after writing, it is recommended to check the register value, and write this register again if necessary. This register is cleared upon a USB reset.

	7	6	5	4	3	2	1	0
	FLENCE				FLENC[3:0]			
Access	R/W				R/W	R/W	R/W	R/W
Reset	0				0	0	0	0

#### Bit 7 – FLENCE Frame Length Control Enable

When this bit is '1', the time between Start-of-Frames can be tuned by up to +/-0.06% using FLENC[3:0].

**Note:** In Low Speed mode, FLENCE must be '0'.

Value	Description
0	Start-of-Frame is generated every 1ms.
1	Start-of-Frame generation depends on the signed value of FLENC[3:0]. USB Start-of-Frame period equals 1ms + (FLENC[3:0]/12000)ms

#### Bits 3:0 – FLENC[3:0] Frame Length Control

These bits define the signed value of the 4-bit FLENC that is added to the Internal Frame Length when FLENCE is '1'. The internal Frame length is the top value of the frame counter when FLENCE is zero.

### 38.8.5.3 Status

**Name:** STATUS  
**Offset:** 0x0C  
**Reset:** 0x00  
**Property:** Read only

Bit	7	6	5	4	3	2	1	0
	LINESTATE[1:0]				SPEED[1:0]			
Access	R	R			R/W	R/W		
Reset	0	0			0	0		

#### Bits 7:6 – LINESTATE[1:0] USB Line State Status

These bits define the current line state DP/DM.

LINESTATE[1:0]	USB Line Status
0x0	SE0/RESET
0x1	FS-J or LS-K State
0x2	FS-K or LS-J State

#### Bits 3:2 – SPEED[1:0] Speed Status

These bits define the current speed used by the host.

SPEED[1:0]	Speed Status
0x0	Full-speed mode
0x1	Low-speed mode
0x2	Reserved
0x3	Reserved

### 38.8.5.4 Host Frame Number

**Name:** FNUM  
**Offset:** 0x10  
**Reset:** 0x0000  
**Property:** PAC Write-Protection

Bit	15	14	13	12	11	10	9	8
			FNUM[10:5]					
Access			R/W	R/W	R/W	R/W	R/W	R/W
Reset			0	0	0	0	0	0
Bit	7	6	5	4	3	2	1	0
	FNUM[4:0]							
Access	R/W	R/W	R/W	R/W	R/W			
Reset	0	0	0	0	0			

#### Bits 13:3 – FNUM[10:0] Frame Number

These bits contains the current SOF number.

These bits can be written by software to initialize a new frame number value. In this case, at the next SOF, the FNUM field takes its new value.

As the FNUM register lies across two consecutive byte addresses, writing byte-wise (8-bits) to the FNUM register may produce incorrect frame number generation. It is recommended to write FNUM register word-wise (32-bits) or half-word-wise (16-bits).

### 38.8.5.5 Host Frame Length

**Name:** FLENHIGH  
**Offset:** 0x12  
**Reset:** 0x00  
**Property:** Read-Only

Bit	7	6	5	4	3	2	1	0
	FLENHIGH[7:0]							
Access	R	R	R	R	R	R	R	R
Reset	0	0	0	0	0	0	0	0

#### Bits 7:0 – FLENHIGH[7:0] Frame Length

These bits contains the 8 high-order bits of the internal frame counter.

**Table 38-9. Counter Description vs. Speed**

Host Register STATUS.SPEED	Description
Full Speed	With a USB clock running at 12MHz, counter length is 12000 to ensure a SOF generation every 1 ms.



### 38.8.5.6 Host Interrupt Enable Register Clear

**Name:** INTENCLR  
**Offset:** 0x14  
**Reset:** 0x0000  
**Property:** PAC Write-Protection

This register allows the user to disable an interrupt without doing a read-modify-write operation. Changes in this register will also be reflected in the Interrupt Enable Set (INTENSET) register.

	15	14	13	12	11	10	9	8
							DDISC	DCONN
Access							R/W	R/W
Reset							0	0
	7	6	5	4	3	2	1	0
	RAMACER	UPRSM	DNRSM	WAKEUP	RST	HSOF		
Access	R/W	R/W	R/W	R/W	R/W	R/W		
Reset	0	0	0	0	0	0		

#### Bit 9 – DDISC Device Disconnection Interrupt Disable

Writing a zero to this bit has no effect.

Writing a one to this bit will clear the Device Disconnection interrupt Enable bit and disable the corresponding interrupt request.

Value	Description
0	The Device Disconnection interrupt is disabled.
1	The Device Disconnection interrupt is enabled and an interrupt request will be generated when the Device Disconnection interrupt Flag is set.

#### Bit 8 – DCONN Device Connection Interrupt Disable

Writing a zero to this bit has no effect.

Writing a one to this bit will clear the Device Connection interrupt Enable bit and disable the corresponding interrupt request.

Value	Description
0	The Device Connection interrupt is disabled.
1	The Device Connection interrupt is enabled and an interrupt request will be generated when the Device Connection interrupt Flag is set.

#### Bit 7 – RAMACER RAM Access Interrupt Disable

Writing a zero to this bit has no effect.

Writing a one to this bit will clear the RAM Access interrupt Enable bit and disable the corresponding interrupt request.

Value	Description
0	The RAM Access interrupt is disabled.
1	The RAM Access interrupt is enabled and an interrupt request will be generated when the RAM Access interrupt Flag is set.

#### Bit 6 – UPRSM Upstream Resume from Device Interrupt Disable

Writing a zero to this bit has no effect.

# SAM D5x/E5x Family Data Sheet

## USB – Universal Serial Bus

Writing a one to this bit will clear the Upstream Resume interrupt Enable bit and disable the corresponding interrupt request.

Value	Description
0	The Upstream Resume interrupt is disabled.
1	The Upstream Resume interrupt is enabled and an interrupt request will be generated when the Upstream Resume interrupt Flag is set.

### Bit 5 – DNRSM Down Resume Interrupt Disable

Writing a zero to this bit has no effect.

Writing a one to this bit will clear the Down Resume interrupt Enable bit and disable the corresponding interrupt request.

Value	Description
0	The Down Resume interrupt is disabled.
1	The Down Resume interrupt is enabled and an interrupt request will be generated when the Down Resume interrupt Flag is set.

### Bit 4 – WAKEUP Wake Up Interrupt Disable

Writing a zero to this bit has no effect.

Writing a one to this bit will clear the Wake Up interrupt Enable bit and disable the corresponding interrupt request.

Value	Description
0	The Wake Up interrupt is disabled.
1	The Wake Up interrupt is enabled and an interrupt request will be generated when the Wake Up interrupt Flag is set.

### Bit 3 – RST BUS Reset Interrupt Disable

Writing a zero to this bit has no effect.

Writing a one to this bit will clear the Bus Reset interrupt Enable bit and disable the corresponding interrupt request.

Value	Description
0	The Bus Reset interrupt is disabled.
1	The Bus Reset interrupt is enabled and an interrupt request will be generated when the Bus Reset interrupt Flag is set.

### Bit 2 – HSOF Host Start-of-Frame Interrupt Disable

Writing a zero to this bit has no effect.

Writing a one to this bit will clear the Host Start-of-Frame interrupt Enable bit and disable the corresponding interrupt request.

Value	Description
0	The Host Start-of-Frame interrupt is disabled.
1	The Host Start-of-Frame interrupt is enabled and an interrupt request will be generated when the Host Start-of-Frame interrupt Flag is set.

### 38.8.5.7 Host Interrupt Enable Register Set

**Name:** INTENSET  
**Offset:** 0x18  
**Reset:** 0x0000  
**Property:** PAC Write-Protection

This register allows the user to enable an interrupt without doing a read-modify-write operation. Changes in this register will also be reflected in the Interrupt Enable Clear (INTENCLR) register.

Bit	15	14	13	12	11	10	9	8
							DDISC	DCONN
Access							R/W	R/W
Reset							0	0
Bit	7	6	5	4	3	2	1	0
	RAMACER	UPRSM	DNRSM	WAKEUP	RST	HSOF		
Access	R/W	R/W	R/W	R/W	R/W	R/W		
Reset	0	0	0	0	0	0		

#### Bit 9 – DDISC Device Disconnection Interrupt Enable

Writing a zero to this bit has no effect.

Writing a one to this bit will set the Device Disconnection interrupt bit and enable the DDSIC interrupt.

Value	Description
0	The Device Disconnection interrupt is disabled.
1	The Device Disconnection interrupt is enabled.

#### Bit 8 – DCONN Device Connection Interrupt Enable

Writing a zero to this bit has no effect.

Writing a one to this bit will set the Device Connection interrupt bit and enable the DCONN interrupt.

Value	Description
0	The Device Connection interrupt is disabled.
1	The Device Connection interrupt is enabled.

#### Bit 7 – RAMACER RAM Access Interrupt Enable

Writing a zero to this bit has no effect.

Writing a one to this bit will set the RAM Access interrupt bit and enable the RAMACER interrupt.

Value	Description
0	The RAM Access interrupt is disabled.
1	The RAM Access interrupt is enabled.

#### Bit 6 – UPRSM Upstream Resume from the device Interrupt Enable

Writing a zero to this bit has no effect.

Writing a one to this bit will set the Upstream Resume interrupt bit and enable the UPRSM interrupt.

Value	Description
0	The Upstream Resume interrupt is disabled.
1	The Upstream Resume interrupt is enabled.

#### Bit 5 – DNRSM Down Resume Interrupt Enable

Writing a zero to this bit has no effect.

Writing a one to this bit will set the Down Resume interrupt Enable bit and enable the DNRSM interrupt.

Value	Description
0	The Down Resume interrupt is disabled.
1	The Down Resume interrupt is enabled.

### Bit 4 – WAKEUP Wake Up Interrupt Enable

Writing a zero to this bit has no effect.

Writing a one to this bit will set the Wake Up interrupt Enable bit and enable the WAKEUP interrupt request.

Value	Description
0	The WakeUp interrupt is disabled.
1	The WakeUp interrupt is enabled.

### Bit 3 – RST Bus Reset Interrupt Enable

Writing a zero to this bit has no effect.

Writing a one to this bit will set the Bus Reset interrupt Enable bit and enable the Bus RST interrupt.

Value	Description
0	The Bus Reset interrupt is disabled.
1	The Bus Reset interrupt is enabled.

### Bit 2 – HSOF Host Start-of-Frame Interrupt Enable

Writing a zero to this bit has no effect.

Writing a one to this bit will set the Host Start-of-Frame interrupt Enable bit and enable the HSOF interrupt.

Value	Description
0	The Host Start-of-Frame interrupt is disabled.
1	The Host Start-of-Frame interrupt is enabled.

### 38.8.5.8 Host Interrupt Flag Status and Clear

**Name:** INTFLAG  
**Offset:** 0x1C  
**Reset:** 0x0000  
**Property:** -

Bit	15	14	13	12	11	10	9	8
							DDISC	DCONN
Access							R/W	R/W
Reset							0	0
Bit	7	6	5	4	3	2	1	0
	RAMACER	UPRSM	DNRSM	WAKEUP	RST	HSOF		
Access	R/W	R/W	R/W	R/W	R/W	R/W		
Reset	0	0	0	0	0	0		

**Bit 9 – DDISC** Device Disconnection Interrupt Flag

This flag is cleared by writing a one to the flag.

This flag is set when the device has been removed from the USB Bus and will generate an interrupt if INTENCLR/SET.DDISC is one.

Writing a zero to this bit has no effect.

Writing a one to this bit clears the DDISC Interrupt Flag.

**Bit 8 – DCONN** Device Connection Interrupt Flag

This flag is cleared by writing a one to the flag.

This flag is set when a new device has been connected to the USB BUS and will generate an interrupt if INTENCLR/SET.DCONN is one.

Writing a zero to this bit has no effect.

Writing a one to this bit clears the DCONN Interrupt Flag.

**Bit 7 – RAMACER** RAM Access Interrupt Flag

This flag is cleared by writing a one to the flag.

This flag is set when a RAM access error occurs during an OUT stage and will generate an interrupt if INTENCLR/SET.RAMACER is one.

Writing a zero to this bit has no effect.

**Bit 6 – UPRSM** Upstream Resume from the Device Interrupt Flag

This flag is cleared by writing a one to the flag.

This flag is set when the USB has received an Upstream Resume signal from the Device and will generate an interrupt if INTENCLR/SET.UPRSM is one.

Writing a zero to this bit has no effect.

**Bit 5 – DNRSM** Down Resume Interrupt Flag

This flag is cleared by writing a one to the flag.

This flag is set when the USB has sent a Down Resume and will generate an interrupt if INTENCLR/SET.DRSM is one.

Writing a zero to this bit has no effect.

**Bit 4 – WAKEUP** Wake Up Interrupt Flag

This flag is cleared by writing a one.

This flag is set when:

| The host controller is in suspend mode (SOFE is zero) and an upstream resume from the device is detected.

| The host controller is in suspend mode (SOFE is zero) and an device disconnection is detected.

| The host controller is in operational state (VBUSOK is one) and an device connection is detected.

In all cases it will generate an interrupt if INTENCLR/SET.WAKEUP is one.

Writing a zero to this bit has no effect.

**Bit 3 – RST** Bus Reset Interrupt Flag

This flag is cleared by writing a one to the flag.

This flag is set when a Bus “Reset” has been sent to the Device and will generate an interrupt if INTENCLR/SET.RST is one.

Writing a zero to this bit has no effect.

**Bit 2 – HSOF** Host Start-of-Frame Interrupt Flag

This flag is cleared by writing a one to the flag.

This flag is set when a USB “Host Start-of-Frame” in Full Speed/High Speed or a keep-alive in Low Speed has been sent (every 1 ms) and will generate an interrupt if INTENCLR/SET.HSOF is one.

The value of the FNUM register is updated.

Writing a zero to this bit has no effect.

### 38.8.5.9 Pipe Interrupt Summary

**Name:** PINTSMRY  
**Offset:** 0x20  
**Reset:** 0x0000  
**Property:** Read-only

Bit	15	14	13	12	11	10	9	8
	PINT[15:8]							
Access	R	R	R	R	R	R	R	R
Reset	0	0	0	0	0	0	0	0
Bit	7	6	5	4	3	2	1	0
	PINT[7:0]							
Access	R	R	R	R	R	R	R	R
Reset	0	0	0	0	0	0	0	0

#### Bits 15:0 – PINT[15:0]

The flag PINT[n] is set when an interrupt is triggered by the pipe n. See [38.8.6.6 PINTFLAG](#) register in the Host Pipe Register section.

This bit will be cleared when there are no interrupts pending for Pipe n.

Writing to this bit has no effect.

### 38.8.6 Host Registers - Pipe

### 38.8.6.1 Host Pipe n Configuration

**Name:** PCFGn  
**Offset:** 0x100 + (n x 0x20)  
**Reset:** 0x00  
**Property:** PAC Write-Protection

	Bit	7	6	5	4	3	2	1	0
				PTYPE[2:0]			BK	PTOKEN[1:0]	
Access				R/W	R/W	R/W	R/W	R/W	R/W
Reset				0	0	0	0	0	0

**Bits 5:3 – PTYPE[2:0]** Type of the Pipe  
 These bits contains the pipe type.

PTYPE[2:0]	Description
0x0	Pipe is disabled
0x1	Pipe is enabled and configured as CONTROL
0x2	Pipe is enabled and configured as ISO
0x3	Pipe is enabled and configured as BULK
0x4	Pipe is enabled and configured as INTERRUPT
0x5	Pipe is enabled and configured as EXTENDED
0x06-0x7	Reserved

These bits are cleared upon sending a USB reset.

#### Bit 2 – BK Pipe Bank

This bit selects the number of banks for the pipe.  
 For control endpoints writing a zero to this bit is required as only Bank0 is used for Setup/In/Out transactions.

This bit is cleared when a USB reset is sent.

BK(1)	Description
0x0	Single-bank endpoint
0x1	Dual-bank endpoint

- Bank field is ignored when PTYPE is configured as EXTENDED.

Value	Description
0	A single bank is used for the pipe.
1	A dual bank is used for the pipe.

#### Bits 1:0 – PTOKEN[1:0] Pipe Token

These bits contains the pipe token.



# SAM D5x/E5x Family Data Sheet

## USB – Universal Serial Bus

PTOKEN[1:0](1)	Description
0x0	SETUP(2)
0x1	IN
0x2	OUT
0x3	Reserved

1. PTOKEN field is ignored when PTYPE is configured as EXTENDED.
2. Available only when PTYPE is configured as CONTROL

These bits are cleared upon sending a USB reset.

### 38.8.6.2 Interval for the Bulk-Out/Ping Transaction

**Name:** BINTERVAL  
**Offset:** 0x103 + (n x 0x20)  
**Reset:** 0x00  
**Property:** PAC Write-Protection

Bit	7	6	5	4	3	2	1	0
	BINTERVAL[7:0]							
Access	R/W	R/W	R/W	R/W	R/W	R/W	R/W	R/W
Reset	0	0	0	0	0	0	0	0

#### Bits 7:0 – BINTERVAL[7:0] BINTERVAL

These bits contains the Ping/Bulk-out period.

These bits are cleared when a USB reset is sent or when PEN[n] is zero.

BINTERVAL	Description
=0	Multiple consecutive OUT token is sent in the same frame until it is acked by the peripheral
>0	One OUT token is sent every BINTERVAL frame until it is acked by the peripheral

Depending from the type of pipe the desired period is defined as:

PTYPE	Description
Interrupt	1 ms to 255 ms
Isochronous	$2^{(Binterval)} * 1 \text{ ms}$
Bulk or control	1 ms to 255 ms
EXT LPM	bInterval ignored. Always 1 ms when a NYET is received.

### 38.8.6.3 Pipe Status Clear n

**Name:** PSTATUSCLR  
**Offset:** 0x104 + (n x 0x20)  
**Reset:** 0x00  
**Property:** PAC Write-Protection

	7	6	5	4	3	2	1	0
Bit	BK1RDY	BK0RDY		PFREEZE		CURBK		DTGL
Access	W	W		W		W		W
Reset	0	0		0		0		0

**Bit 7 – BK1RDY** Bank 1 Ready Clear  
 Writing a zero to this bit has no effect.  
 Writing a one to this bit will clear PSTATUS.BK1RDY bit.

**Bit 6 – BK0RDY** Bank 0 Ready Clear  
 Writing a zero to this bit has no effect.  
 Writing a one to this bit will clear PSTATUS.BK0RDY bit.

**Bit 4 – PFREEZE** Pipe Freeze Clear  
 Writing a zero to this bit has no effect.  
 Writing a one to this bit will clear PSTATUS.PFREEZE bit.

**Bit 2 – CURBK** Current Bank Clear  
 Writing a zero to this bit has no effect.  
 Writing a one to this bit will clear PSTATUS.CURBK bit.

**Bit 0 – DTGL** Data Toggle Clear  
 Writing a zero to this bit has no effect.  
 Writing a one to this bit will clear PSTATUS.DTGL bit.

### 38.8.6.4 Pipe Status Set Register n

**Name:** PSTATUSSET  
**Offset:** 0x105 + (n x 0x20)  
**Reset:** 0x00  
**Property:** PAC Write-Protection

	7	6	5	4	3	2	1	0
Bit	BK1RDY	BK0RDY		PFREEZE		CURBK		DTGL
Access	W	W		W		W		W
Reset	0	0		0		0		0

**Bit 7 – BK1RDY** Bank 1 Ready Set  
 Writing a zero to this bit has no effect.  
 Writing a one to this bit will set the bit PSTATUS.BK1RDY.

**Bit 6 – BK0RDY** Bank 0 Ready Set  
 Writing a zero to this bit has no effect.  
 Writing a one to this bit will set the bit PSTATUS.BK0RDY.

**Bit 4 – PFREEZE** Pipe Freeze Set  
 Writing a zero to this bit has no effect.  
 Writing a one to this bit will set PSTATUS.PFREEZE bit.

**Bit 2 – CURBK** Current Bank Set  
 Writing a zero to this bit has no effect.  
 Writing a one to this bit will set PSTATUS.CURBK bit.

**Bit 0 – DTGL** Data Toggle Set  
 Writing a zero to this bit has no effect.  
 Writing a one to this bit will set PSTATUS.DTGL bit.

### 38.8.6.5 Pipe Status Register n

**Name:** PSTATUS  
**Offset:** 0x106 + (n x 0x20)  
**Reset:** 0x00  
**Property:** PAC Write-Protection

Bit	7	6	5	4	3	2	1	0
	BK1RDY	BK0RDY		PFREEZE		CURBK		DTGL
Access	R	R		R		R		R
Reset	0	0		0		0		0

#### Bit 7 – BK1RDY Bank 1 is ready

Writing a one to the bit EPSTATUSCLR.BK1RDY will clear this bit.

Writing a one to the bit EPSTATUSSET.BK1RDY will set this bit.

This bank is not used for Control pipe.

Value	Description
0	The bank number 1 is not ready: For IN the bank is empty. For Control/OUT the bank is not yet fill in.
1	The bank number 1 is ready: For IN the bank is filled full. For Control/OUT the bank is filled in.

#### Bit 6 – BK0RDY Bank 0 is ready

Writing a one to the bit EPSTATUSCLR.BK0RDY will clear this bit.

Writing a one to the bit EPSTATUSSET.BK0RDY will set this bit.

This bank is the only one used for Control pipe.

Value	Description
0	The bank number 0 is not ready: For IN the bank is not empty. For Control/OUT the bank is not yet fill in.
1	The bank number 0 is ready: For IN the bank is filled full. For Control/OUT the bank is filled in.

#### Bit 4 – PFREEZE Pipe Freeze

Writing a one to the bit EPSTATUSCLR.PFREEZE will clear this bit.

Writing a one to the bit EPSTATUSSET.PFREEZE will set this bit.

This bit is also set by the hardware:

- When a STALL handshake has been received.
- After a PIPE has been enabled (rising of bit PEN.N).
- When an LPM transaction has completed whatever handshake is returned or the transaction was timed-out.
- When a pipe transfer was completed with a pipe error. See [38.8.6.6 PINTFLAG](#) register.

When PFREEZE bit is set while a transaction is in progress on the USB bus, this transaction will be properly completed. PFREEZE bit will be read as “1” only when the ongoing transaction will have been completed.

Value	Description
0	The Pipe operates in normal operation.
1	The Pipe is frozen and no additional requests will be sent to the device on this pipe address.

---

---

**Bit 2 – CURBK** Current Bank

Value	Description
0	The bank0 is the bank that will be used in the next single/multi USB packet.
1	The bank1 is the bank that will be used in the next single/multi USB packet.

**Bit 0 – DTGL** Data Toggle Sequence

Writing a one to the bit EPSTATUSCLR.DTGL will clear this bit.

Writing a one to the bit EPSTATUSSET.DTGL will set this bit.

This bit is toggled automatically by hardware after a data transaction.

This bit will reflect the data toggle in regards of the token type (IN/OUT/SETUP).

Value	Description
0	The PID of the next expected transaction will be zero: data 0.
1	The PID of the next expected transaction will be one: data 1.

### 38.8.6.6 Host Pipe Interrupt Flag Register

**Name:** PINTFLAG  
**Offset:** 0x107 + (n x 0x20)  
**Reset:** 0x00  
**Property:** -

	7	6	5	4	3	2	1	0
Access			R/W	R/W	R/W	R/W		R/W
Reset			0	0	0	0		2

**Bit 5 – STALL** STALL Received Interrupt Flag

This flag is cleared by writing a one to the flag.

This flag is set when a stall occurs and will generate an interrupt if PINTENCLR/SET.STALL is one.

Writing a zero to this bit has no effect.

Writing a one to this bit clears the STALL Interrupt Flag.

**Bit 4 – TXSTP** Transmitted Setup Interrupt Flag

This flag is cleared by writing a one to the flag.

This flag is set when a Transfer Complete occurs and will generate an interrupt if PINTENCLR/SET.TXSTP is one.

Writing a zero to this bit has no effect.

Writing a one to this bit clears the TXSTP Interrupt Flag.

**Bit 3 – PERR** Pipe Error Interrupt Flag

This flag is cleared by writing a one to the flag.

This flag is set when a pipe error occurs and will generate an interrupt if PINTENCLR/SET.PERR is one.

Writing a zero to this bit has no effect.

Writing a one to this bit clears the PERR Interrupt Flag.

**Bit 2 – TRFAIL** Transfer Fail Interrupt Flag

This flag is cleared by writing a one to the flag.

This flag is set when a Transfer Fail occurs and will generate an interrupt if PINTENCLR/SET.TRFAIL is one.

Writing a zero to this bit has no effect.

Writing a one to this bit clears the TRFAIL Interrupt Flag.

**Bit 0 – TRCPT** Transfer Complete x interrupt Flag

This flag is cleared by writing a one to the flag.

This flag is set when a Transfer complete occurs and will generate an interrupt if PINTENCLR/SET.TRCPT is one. PINTFLAG.TRCPT is set for a single bank IN/OUT pipe or a double bank IN/OUT pipe when current bank is 0.

Writing a zero to this bit has no effect.

Writing a one to this bit clears the TRCPT Interrupt Flag.

### 38.8.6.7 Host Pipe Interrupt Clear Register

**Name:** PINTENCLR  
**Offset:** 0x108 + (n x 0x20)  
**Reset:** 0x00  
**Property:** PAC Write-Protection

This register allows the user to disable an interrupt without doing a read-modify-write operation. Changes in this register will also be reflected in the Pipe Interrupt Enable Set (PINTENSET) register.

This register is cleared by USB reset or when PEN[n] is zero.

	7	6	5	4	3	2	1	0
Bit			STALL	TXSTP	PERR	TRFAIL		TRCPT
Access			R/W	R/W	R/W	R/W		R/W
Reset			0	0	0	0		2

#### Bit 5 – STALL Received Stall Interrupt Disable

Writing a zero to this bit has no effect.

Writing a one to this bit will clear the Received Stall interrupt Enable bit and disable the corresponding interrupt request.

Value	Description
0	The received Stall interrupt is disabled.
1	The received Stall interrupt is enabled and an interrupt request will be generated when the received Stall interrupt Flag is set.

#### Bit 4 – TXSTP Transmitted Setup Interrupt Disable

Writing a zero to this bit has no effect.

Writing a one to this bit will clear the Transmitted Setup interrupt Enable bit and disable the corresponding interrupt request.

Value	Description
0	The Transmitted Setup interrupt is disabled.
1	The Transmitted Setup interrupt is enabled and an interrupt request will be generated when the Transmitted Setup interrupt Flag is set.

#### Bit 3 – PERR Pipe Error Interrupt Disable

Writing a zero to this bit has no effect.

Writing a one to this bit will clear the Pipe Error interrupt Enable bit and disable the corresponding interrupt request.

Value	Description
0	The Pipe Error interrupt is disabled.
1	The Pipe Error interrupt is enabled and an interrupt request will be generated when the Pipe Error interrupt Flag is set.

#### Bit 2 – TRFAIL Transfer Fail Interrupt Disable

Writing a zero to this bit has no effect.

Writing a one to this bit will clear the Transfer Fail interrupt Enable bit and disable the corresponding interrupt request.

Value	Description
0	The Transfer Fail interrupt is disabled.



---

---

Value	Description
1	The Transfer Fail interrupt is enabled and an interrupt request will be generated when the Transfer Fail interrupt Flag is set.

**Bit 0 – TRCPT** Transfer Complete Bank x interrupt Disable

Writing a zero to this bit has no effect.

Writing a one to this bit will clear the Transfer Complete interrupt Enable bit x and disable the corresponding interrupt request.

Value	Description
0	The Transfer Complete Bank x interrupt is disabled.
1	The Transfer Complete Bank x interrupt is enabled and an interrupt request will be generated when the Transfer Complete interrupt x Flag is set.

### 38.8.6.8 Host Interrupt Pipe Set Register

**Name:** PINTENSET  
**Offset:** 0x109 + (n x 0x20)  
**Reset:** 0x00  
**Property:** PAC Write-Protection

This register allows the user to enable an interrupt without doing a read-modify-write operation. Changes in this register will also be reflected in the Pipe Interrupt Enable Set (PINTENCLR) register.

This register is cleared by USB reset or when PEN[n] is zero.

	7	6	5	4	3	2	1	0
			STALL	TXSTP	PERR	TRFAIL		TRCPT
Access			R/W	R/W	R/W	R/W		R/W
Reset			0	0	0	0		2

**Bit 5 – STALL** Stall Interrupt Enable  
 Writing a zero to this bit has no effect.  
 Writing a one to this bit will enable the Stall interrupt.

Value	Description
0	The Stall interrupt is disabled.
1	The Stall interrupt is enabled.

**Bit 4 – TXSTP** Transmitted Setup Interrupt Enable  
 Writing a zero to this bit has no effect.  
 Writing a one to this bit will enable the Transmitted Setup interrupt.

Value	Description
0	The Transmitted Setup interrupt is disabled.
1	The Transmitted Setup interrupt is enabled.

**Bit 3 – PERR** Pipe Error Interrupt Enable  
 Writing a zero to this bit has no effect.  
 Writing a one to this bit will enable the Pipe Error interrupt.

Value	Description
0	The Pipe Error interrupt is disabled.
1	The Pipe Error interrupt is enabled.

**Bit 2 – TRFAIL** Transfer Fail Interrupt Enable  
 Writing a zero to this bit has no effect.  
 Writing a one to this bit will enable the Transfer Fail interrupt.

Value	Description
0	The Transfer Fail interrupt is disabled.
1	The Transfer Fail interrupt is enabled.

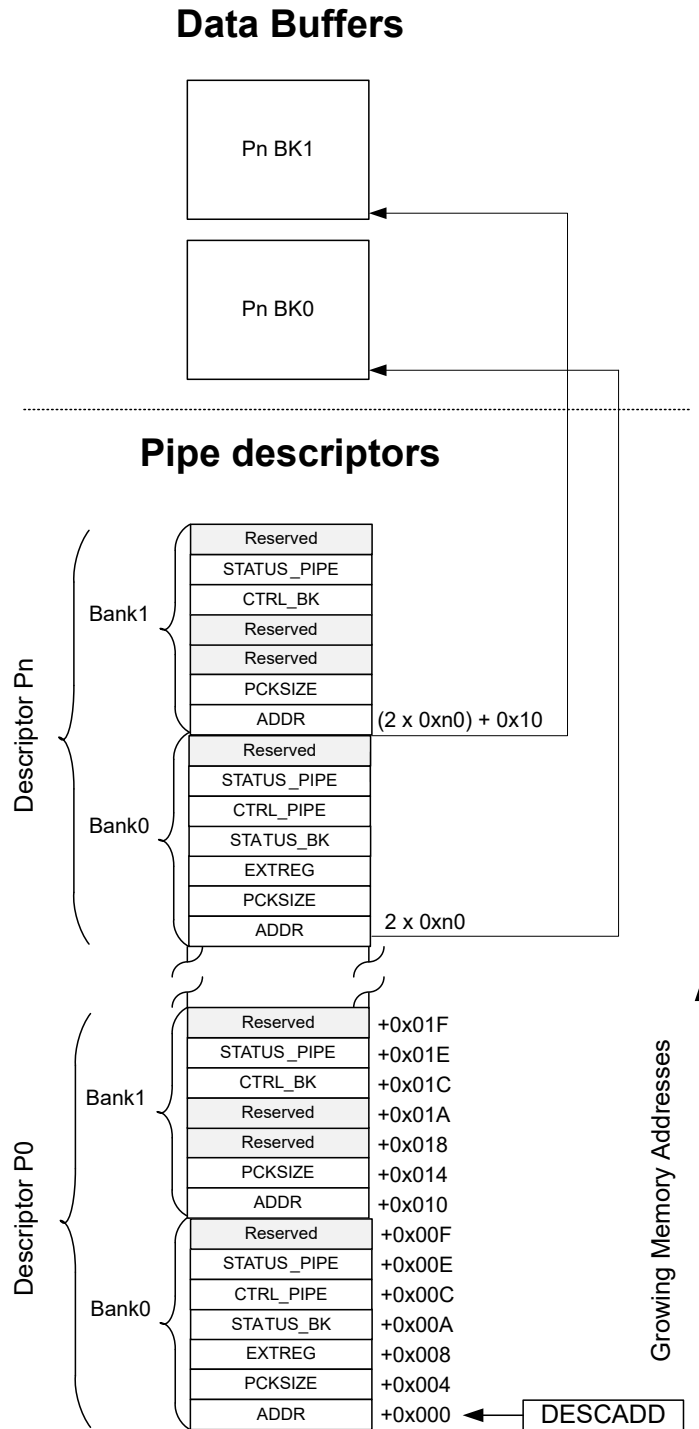
**Bit 0 – TRCPT** Transfer Complete x interrupt Enable  
 Writing a zero to this bit has no effect.  
 Writing a one to this bit will enable the Transfer Complete interrupt Enable bit x.

#### 0.2.7 Host Registers - Pipe RAM

Value	Description
0	The Transfer Complete x interrupt is disabled.
1	The Transfer Complete x interrupt is enabled.

### 38.8.7 Host Registers - Pipe RAM

#### 38.8.7.1 Pipe Descriptor Structure



# SAM D5x/E5x Family Data Sheet

## USB – Universal Serial Bus

### 38.8.7.2 Address of the Data Buffer

**Name:** ADDR  
**Offset:** 0x00 & 0x10  
**Reset:** 0xxxxxxx  
**Property:** NA

Bit	31	30	29	28	27	26	25	24
ADDR[31:24]								
Access	R/W	R/W	R/W	R/W	R/W	R/W	R/W	R/W
Reset	0	0	0	0	0	0	0	0
Bit	23	22	21	20	19	18	17	16
ADDR[23:16]								
Access	R/W	R/W	R/W	R/W	R/W	R/W	R/W	R/W
Reset	0	0	0	0	0	0	0	0
Bit	15	14	13	12	11	10	9	8
ADDR[15:8]								
Access	R/W	R/W	R/W	R/W	R/W	R/W	R/W	R/W
Reset	0	0	0	0	0	0	0	0
Bit	7	6	5	4	3	2	1	0
ADDR[7:0]								
Access	R/W	R/W	R/W	R/W	R/W	R/W	R/W	R/W
Reset	0	0	0	0	0	0	0	x

**Bits 31:0 – ADDR[31:0]** Data Pointer Address Value

These bits define the data pointer address as an absolute double word address in RAM. The two least significant bits must be zero to ensure the descriptor is 32-bit aligned.

# SAM D5x/E5x Family Data Sheet

## USB – Universal Serial Bus

### 38.8.7.3 Packet Size

**Name:** PCKSIZE  
**Offset:** 0x04 & 0x14  
**Reset:** 0xxxxxxx  
**Property:** NA

	Bit	31	30	29	28	27	26	25	24
		AUTO_ZLP	SIZE[2:0]			MULTI_PACKET_SIZE[13:10]			
Access		R/W	R/W	R/W	R/W	R/W	R/W	R/W	R/W
Reset		x	0	0	x	0	0	0	0
	Bit	23	22	21	20	19	18	17	16
		MULTI_PACKET_SIZE[9:2]							
Access		R/W	R/W	R/W	R/W	R/W	R/W	R/W	R/W
Reset		0	0	0	0	0	0	0	0
	Bit	15	14	13	12	11	10	9	8
		MULTI_PACKET_SIZE[1:0]			BYTE_COUNT[5:0]				
Access		R/W	R/W	R/W	R/W	R/W	R/W	R/W	R/W
Reset		0	x	0	0	0	0	0	x
	Bit	7	6	5	4	3	2	1	0
Access									
Reset									

#### Bit 31 – AUTO\_ZLP Automatic Zero Length Packet

This bit defines the automatic Zero Length Packet mode of the pipe.

When enabled, the USB module will manage the ZLP handshake by hardware. This bit is for OUT pipes only. When disabled the handshake should be managed by firmware.

Value	Description
0	Automatic Zero Length Packet is disabled.
1	Automatic Zero Length Packet is enabled.

#### Bits 30:28 – SIZE[2:0] Pipe size

These bits contains the size of the pipe.

Theses bits are cleared upon sending a USB reset.

SIZE[2:0]	Description
0x0	8 Byte
0x1	16 Byte
0x2	32 Byte
0x3	64 Byte
0x4	128 Byte <sup>(1)</sup>
0x5	256 Byte <sup>(1)</sup>

.....continued	
SIZE[2:0]	Description
0x6	512 Byte <sup>(1)</sup>
0x7	1024 Byte in HS mode <sup>(1)</sup> 1023 Byte in FS mode <sup>(1)</sup>

1. For Isochronous pipe only.

**Bits 27:14 – MULTI\_PACKET\_SIZE[13:0]** Multi Packet IN or OUT size

These bits define the 14-bit value that is used for multi-packet transfers.

For IN pipes, MULTI\_PACKET\_SIZE holds the total number of bytes sent. MULTI\_PACKET\_SIZE should be written to zero when setting up a new transfer.

For OUT pipes, MULTI\_PACKET\_SIZE holds the total data size for the complete transfer. This value must be a multiple of the maximum packet size.

**Bits 13:8 – BYTE\_COUNT[5:0]** Byte Count

These bits define the 14-bit value that contains number of bytes sent in the last OUT or SETUP transaction for an OUT pipe, or of the number of bytes to be received in the next IN transaction for an input pipe.

# SAM D5x/E5x Family Data Sheet

## USB – Universal Serial Bus

### 38.8.7.4 Extended Register

**Name:** EXTREG  
**Offset:** 0x08  
**Reset:** 0xxxxxxx  
**Property:** NA

	Bit	15	14	13	12	11	10	9	8
		VARIABLE[10:4]							
Access			R/W	R/W	R/W	R/W	R/W	R/W	R/W
Reset			0	0	0	0	0	0	0
	Bit	7	6	5	4	3	2	1	0
		VARIABLE[3:0]				SUBPID[3:0]			
Access		R/W	R/W	R/W	R/W	R/W	R/W	R/W	R/W
Reset		0	0	0	x	0	0	0	x

#### Bits 14:4 – VARIABLE[10:0] Variable field send with extended token

These bits define the VARIABLE field sent with extended token. See “Section 2.1.1 Protocol Extension Token in the reference document ENGINEERING CHANGE NOTICE, USB 2.0 Link Power Management Addendum.”

To support the USB2.0 Link Power Management addition the VARIABLE field should be set as described below.

VARIABLE	Description
VARIABLE[3:0]	bLinkState <sup>(1)</sup>
VARIABLE[7:4]	BESL (See LPM ECN) <sup>(2)</sup>
VARIABLE[8]	bRemoteWake <sup>(1)</sup>
VARIABLE[10:9]	Reserved

(1) for a definition of LPM Token bRemoteWake and bLinkState fields, refer to "Table 2-3 in the reference document ENGINEERING CHANGE NOTICE, USB 2.0 Link Power Management Addendum"

(2) for a definition of LPM Token BESL field, refer to "Table 2-3 in the reference document ENGINEERING CHANGE NOTICE, USB 2.0 Link Power Management Addendum" and "Table X-X1 in Errata for ECN USB 2.0 Link Power Management."

#### Bits 3:0 – SUBPID[3:0] SUBPID field send with extended token

These bits define the SUBPID field sent with extended token. See “Section 2.1.1 Protocol Extension Token in the reference document ENGINEERING CHANGE NOTICE, USB 2.0 Link Power Management Addendum”.

To support the USB2.0 Link Power Management addition the SUBPID field should be set as described in “Table 2.2 SubPID Types in the reference document ENGINEERING CHANGE NOTICE, USB 2.0 Link Power Management Addendum”.

### 38.8.7.5 Host Status Bank

**Name:** STATUS\_BK  
**Offset:** 0x0A & 0x1A  
**Reset:** 0xxxxxxx  
**Property:** NA

	7	6	5	4	3	2	1	0
							ERRORFLOW	CRCERR
Access							R/W	R/W
Reset							x	x

#### Bit 1 – ERRORFLOW Error Flow Status

This bit defines the Error Flow Status.

This bit is set when a Error Flow has been detected during transfer from/towards this bank.

For IN transfer, a NAK handshake has been received. For OUT transfer, a NAK handshake has been received. For Isochronous IN transfer, an overrun condition has occurred. For Isochronous OUT transfer, an underflow condition has occurred.

Value	Description
0	No Error Flow detected.
1	A Error Flow has been detected.

#### Bit 0 – CRCERR CRC Error

This bit defines the CRC Error Status.

This bit is set when a CRC error has been detected in an isochronous IN endpoint bank.

Value	Description
0	No CRC Error.
1	CRC Error detected.



### 38.8.7.6 Host Control Pipe

**Name:** CTRL\_PIPE  
**Offset:** 0x0C  
**Reset:** 0XXXXX  
**Property:** PAC Write-Protection, Write-Synchronized, Read-Synchronized

	Bit	15	14	13	12	11	10	9	8
		PERMAX[3:0]				PEPNUM[3:0]			
Access		R/W	R/W	R/W	R/W	R/W	R/W	R/W	R/W
Reset		0	0	0	x	0	0	0	x
	Bit	7	6	5	4	3	2	1	0
		PDADDR[6:0]							
Access			R/W	R/W	R/W	R/W	R/W	R/W	R/W
Reset			0	0	0	0	0	0	x

**Bits 15:12 – PERMAX[3:0]** Pipe Error Max Number

These bits define the maximum number of error for this Pipe before freezing the pipe automatically.

**Bits 11:8 – PEPNUM[3:0]** Pipe EndPoint Number

These bits define the number of endpoint for this Pipe.

**Bits 6:0 – PDADDR[6:0]** Pipe Device Address

These bits define the Device Address for this pipe.

### 38.8.7.7 Host Status Pipe

**Name:** STATUS\_PIPE  
**Offset:** 0x0E & 0x1E  
**Reset:** 0xxxxxxx  
**Property:** PAC Write-Protection, Write-Synchronized, Read-Synchronized

Bit	15	14	13	12	11	10	9	8
Access								
Reset								
Bit	7	6	5	4	3	2	1	0
	ERCNT[2:0]			CRC16ER	TOUTER	PIDER	DAPIDER	DTGLER
Access	R/W	R/W	R/W	R/W	R/W	R/W	R/W	R/W
Reset	0	0	x	x	x	x	x	x

**Bits 7:5 – ERCNT[2:0] Pipe Error Counter**  
 These bits define the number of errors detected on the pipe.

**Bit 4 – CRC16ER CRC16 ERROR**  
 This bit defines the CRC16 Error Status.  
 This bit is set when a CRC 16 error has been detected during a IN transactions.

Value	Description
0	No CRC 16 Error detected.
1	A CRC 16 error has been detected.

**Bit 3 – TOUTER TIME OUT ERROR**  
 This bit defines the Time Out Error Status.  
 This bit is set when a Time Out error has been detected during a USB transaction.

Value	Description
0	No Time Out Error detected.
1	A Time Out error has been detected.

**Bit 2 – PIDER PID ERROR**  
 This bit defines the PID Error Status.  
 This bit is set when a PID error has been detected during a USB transaction.

Value	Description
0	No PID Error detected.
1	A PID error has been detected.

**Bit 1 – DAPIDER Data PID ERROR**  
 This bit defines the PID Error Status.  
 This bit is set when a Data PID error has been detected during a USB transaction.

Value	Description
0	No Data PID Error detected.
1	A Data PID error has been detected.

# SAM D5x/E5x Family Data Sheet

## USB – Universal Serial Bus

---

---

**Bit 0 – DTGLER** Data Toggle Error

This bit defines the Data Toggle Error Status.

This bit is set when a Data Toggle Error has been detected.

Value	Description
0	No Data Toggle Error.
1	Data Toggle Error detected.

### 39. CAN - Control Area Network

#### 39.1 Overview

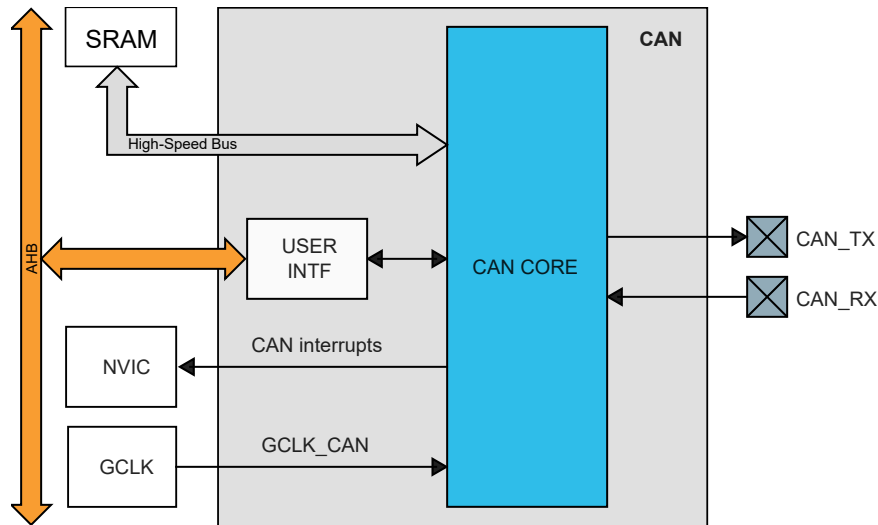
The Control Area Network (CAN) performs communication according to ISO 11898-1:2015 (Bosch CAN specification 2.0 part A,B, ISO CAN FD). The message storage is intended to be a single- or dual-ported Message RAM outside of the module.

#### 39.2 Features

- Conform with CAN protocol version 2.0 part A, B and ISO 11898-1:2015
- Up to two Controller Area Network CAN
  - Supporting CAN2.0 A/B and CAN-FD (ISO 11898-1:2015)
- CAN FD with up to 64 data bytes supported
- CAN Error Logging
- AUTOSAR optimized
- SAE J1939 optimized
- Two configurable Receive FIFOs
- Separate signaling on reception of High-Priority Messages
- Up to 64 dedicated Receive Buffers and up to 32 dedicated Transmit Buffers
- Configurable Transmit FIFO, Transmit Queue, Transmit Event FIFO
- Direct Message RAM access for CPU
- Programmable Loop-Back Test mode
- Maskable module interrupts
- Power-down support; Debug on CAN support
- Transfer rates:
  - 1 Mb/s for CAN 2.0 mode
  - 10 Mb/s for CAN-FD mode

### 39.3 Block Diagram

Figure 39-1. CAN Block Diagram



### 39.4 Signal Description

Table 39-1. Signal Description

Signal	Description	Type
CAN_TX	CAN transmit	Digital output
CAN_RX	CAN receive	Digital input

Refer to for details on the pin mapping for this peripheral. One signal can be mapped to one of several pins.

### 39.5 Product Dependencies

In order to use this peripheral, other parts of the system must be configured correctly, as described below.

#### 39.5.1 I/O Lines

Using the CAN's I/O lines requires the I/O pins to be configured.

#### Related Links

[32. PORT - I/O Pin Controller](#)

#### 39.5.2 Power Management

The CAN will continue to operate in any Idle Sleep mode where the selected source clock is running. The CAN interrupts can be used to wake up the device from sleep modes. Refer to the Power Manager chapter for details on the different sleep modes.

The CAN module has its own Low-Power mode. The clock sources cannot be halted while the CAN is enabled unless this mode is used. Refer to the section "Sleep Mode Operation" for additional information.

#### Related Links

### [39.6.9 Sleep Mode Operation](#)

#### **39.5.3 Clocks**

An AHB clock (CLK\_CAN\_AHB) is required to clock the CAN. This clock can be configured in the Main Clock peripheral (MCLK) before using the CAN, and the default state of CLK\_CAN\_AHB can be found in the MCLK.AHBMASK register.

A generic clock (GCLK\_CAN) is required to clock the CAN. This clock must be configured and enabled in the generic clock controller before using the CAN.

This generic clock is asynchronous to the bus clock (CLK\_CAN\_AHB). Due to this asynchronicity, writes to certain registers will require synchronization between the clock domains.

#### **Related Links**

[15.6.2.6 Peripheral Clock Masking](#)

[14. GCLK - Generic Clock Controller](#)

#### **39.5.4 DMA**

The CAN has a built-in Direct Memory Access (DMA) and will read/write data to/from the system RAM when a CAN transaction takes place. No CPU or DMA Controller (DMAC) resources are required.

The DMAC can be used for debug messages functionality.

#### **Related Links**

[22. DMAC – Direct Memory Access Controller](#)

#### **39.5.5 Interrupts**

The interrupt request lines are connected to the interrupt controller. Using the CAN interrupts requires the interrupt controller to be configured first.

#### **39.5.6 Events**

Not applicable.

#### **39.5.7 Debug Operation**

Not applicable.

#### **39.5.8 Register Access Protection**

Not applicable.

#### **39.5.9 Analog Connections**

No analog connections.

## **39.6 Functional Description**

### **39.6.1 Principle of Operation**

The CAN performs communication according to ISO 11898-1:2015 (identical to Bosch CAN protocol specification 2.0 part A,B, ISO CAN FD).

The message storage is intended to be a single- or dual-ported Message RAM outside the module. It is connected to the CAN via AHB.

All functions concerning the handling of messages are implemented by the Rx Handler and the Tx Handler. The Rx Handler manages message acceptance filtering, the transfer of received messages from

the CAN Core to the Message RAM as well as providing receive message status information. The Tx Handler is responsible for the transfer of transmit messages from the Message RAM to the CAN Core as well as providing transmit status information.

Acceptance filtering is implemented by a combination of up to 128 filter elements where each one can be configured as a range, as a bit mask, or as a dedicated ID filter.

### 39.6.2 Operating Modes

#### 39.6.2.1 Software Initialization

Software initialization is started by setting bit `CCCR.INIT`, either by software or by a hardware reset, when an uncorrected bit error was detected in the Message RAM, or by going `Bus_Off`. While `CCCR.INIT` is set, message transfer from and to the CAN bus is stopped, the status of the CAN bus output `CAN_TX` is "recessive" (HIGH). The counters of the Error Management Logic EML are unchanged. Setting `CCCR.INIT` does not change any configuration register. Resetting `CCCR.INIT` finishes the software initialization. Afterwards the Bit Stream Processor BSP synchronizes itself to the data transfer on the CAN bus by waiting for the occurrence of a sequence of 11 consecutive "recessive" bits (= `Bus_Idle`) before it can take part in bus activities and start the message transfer.

Access to the CAN configuration registers is only enabled when both bits `CCCR.INIT` and `CCCR.CCE` are set (protected write).

`CCCR.CCE` can only be set/reset while `CCCR.INIT = '1'`. `CCCR.CCE` is automatically reset when `CCCR.INIT` is reset.

The following registers are reset when `CCCR.CCE` is set

- HPMS - High Priority Message Status
- RXF0S - Rx FIFO 0 Status
- RXF1S - Rx FIFO 1 Status
- TXFQS - Tx FIFO/Queue Status
- TXBRP - Tx Buffer Request Pending
- TXBTO - Tx Buffer Transmission Occurred
- TXBCF - Tx Buffer Cancellation Finished
- TXEFS - Tx Event FIFO Status

The Timeout Counter value `TOCV.TOC` is preset to the value configured by `TOCC.TOP` when `CCCR.CCE` is set.

In addition the state machines of the Tx Handler and Rx Handler are held in idle state while `CCCR.CCE = '1'`.

The following registers are only writable while `CCCR.CCE = '0'`

- TXBAR - Tx Buffer Add Request
- TXBCR - Tx Buffer Cancellation Request

`CCCR.TEST` and `CCCR.MON` can only be set by the CPU while `CCCR.INIT = '1'` and `CCCR.CCE = '1'`. Both bits may be reset at any time. `CCCR.DAR` can only be set/reset while `CCCR.INIT = '1'` and `CCCR.CCE = '1'`.

#### 39.6.2.2 Normal Operation

Once the CAN is initialized and `CCCR.INIT` is reset to '0', the CAN synchronizes itself to the CAN bus and is ready for communication.

---

After passing the acceptance filtering, received messages including Message ID and DLC are stored into a dedicated Rx Buffer or into Rx FIFO0 or Rx FIFO1.

For messages to be transmitted dedicated Tx Buffers and/or a Tx FIFO or a Tx Queue can be initialized or updated. Automated transmission on reception of remote frames is not implemented.

### 39.6.2.3 CAN FD Operation

There are two variants in the CAN FD frame format, first the CAN FD frame without bit rate switching where the data field of a CAN frame may be longer than 8 bytes. The second variant is the CAN FD frame where control field, data field, and CRC field of a CAN frame are transmitted with a higher bit rate than the beginning and the end of the frame.

The previously reserved bit in CAN frames with 11-bit identifiers and the first previously reserved bit in CAN frames with 29-bit identifiers will now be decoded as FDF bit. FDF = recessive signifies a CAN FD frame, FDF = dominant signifies a Classic CAN frame. In a CAN FD frame, the two bits following FDF, res and BRS, decide whether the bit rate inside of this CAN FD frame is switched. A CAN FD bit rate switch is signified by res = dominant and BRS = recessive. The coding of res = recessive is reserved for future expansion of the protocol. In case the CAN receives a frame with FDF = recessive and res = recessive, it will signal a Protocol Exception Event by setting bit PSR.PXE. When Protocol Exception Handling is enabled (CCCR.PXHD = '0'), this causes the operation state to change from Receiver (PSR.ACT = "10") to Integrating (PSR.ACT = "00") at the next sample point. In case Protocol Exception Handling is disabled (CCCR.PXHD = '1'), the CAN will treat a recessive res bit as a form error and will respond with an error frame.

CAN FD operation is enabled by programming CCCR.FDOE. In case CCCR.FDOE = '1', transmission and reception of CAN FD frames is enabled. Transmission and reception of Classic CAN frames is always possible. Whether a CAN FD frame or a Classic CAN frame is transmitted can be configured via bit FDF in the respective Tx Buffer element. With CCCR.FDOE = '0', received frames are interpreted as Classic CAN frames, which leads to the transmission of an error frame when receiving a CAN FD frame. When CAN FD operation is disabled, no CAN FD frames are transmitted even if bit FDF of a Tx Buffer element is set. CCCR.FDOE and CCCR.BRSE can only be changed while CCCR.INIT and CCCR.CCE are both set.

With CCCR.FDOE = '0', the setting of bits FDF and BRS is ignored and frames are transmitted in Classic CAN format. With CCCR.FDOE = '1' and CCCR.BRSE = '0', only bit FDF of a Tx Buffer element is evaluated. With CCCR.FDOE = '1' and CCCR.BRSE = '1', transmission of CAN FD frames with bit rate switching is enabled. All Tx Buffer elements with bits FDF and BRS set are transmitted in CAN FD format with bit rate switching.

A mode change during CAN operation is only recommended under the following conditions:

- The failure rate in the CAN FD data phase is significantly higher than in the CAN FD arbitration phase. In this case disable the CAN FD bit rate switching option for transmissions.
- During system startup all nodes are transmitting Classic CAN messages until it is verified that they are able to communicate in CAN FD format. If this is true, all nodes switch to CAN FD operation.
- Wake-up messages in CAN Partial Networking have to be transmitted in Classic CAN format.
- End-of-line programming in case not all nodes are CAN FD capable. Non CAN FD nodes are held in silent mode until programming has completed. Then all nodes switch back to Classic CAN communication.

In the CAN FD format, the coding of the DLC differs from the standard CAN format. The DLC codes 0 to 8 have the same coding as in standard CAN, the codes 9 to 15, which in standard CAN all code a data field of 8 bytes, are coded according to the table below.



**Table 39-2. Coding of DLC in CAN FD**

DLC	9	10	11	12	13	14	15
Number of Data Bytes	12	16	20	24	32	48	64

In CAN FD frames, the bit timing will be switched inside the frame, after the BRS (Bit Rate Switch) bit, if this bit is recessive. Before the BRS bit, in the CAN FD arbitration phase, the nominal CAN bit timing is used as defined by the Nominal Bit Timing & Prescaler Register NBTP. In the following CAN FD data phase, the fast CAN bit timing is used as defined by the Data Bit Timing & Prescaler Register DBTP. The bit timing is switched back from the fast timing at the CRC delimiter or when an error is detected, whichever occurs first.

The maximum configurable bit rate in the CAN FD data phase depends on the CAN clock frequency (GCLK\_CAN). Example: with a CAN clock frequency of 20MHz and the shortest configurable bit time of 4  $t_q$ , the bit rate in the data phase is 5 Mbit/s.

In both data frame formats, CAN FD long and CAN FD fast, the value of the bit ESI (Error Status Indicator) is determined by the transmitter's error state at the start of the transmission. If the transmitter is error passive, ESI is transmitted recessive, else it is transmitted dominant.

### 39.6.2.4 Transceiver Delay Compensation

During the data phase of a CAN FD transmission only one node is transmitting, all others are receivers. The length of the bus line has no impact. When transmitting via pin CAN\_TX the CAN receives the transmitted data from its local CAN transceiver via pin CAN\_RX. The received data is delayed by the CAN transceiver's loop delay. In case this delay is greater than TSEG1 (time segment before sample point), a bit error is detected. In order to enable a data phase bit time that is even shorter than the transceiver loop delay, the delay compensation is introduced. Without transceiver delay compensation, the bit rate in the data phase of a CAN FD frame is limited by the transceivers loop delay.

#### Description

The CAN's protocol unit has implemented a delay compensation mechanism to compensate the transmitter delay, thereby enabling transmission with higher bit rates during the CAN FD data phase independent of the delay of a specific CAN transceiver.

To check for bit errors during the data phase of transmitting nodes, the delayed transmit data is compared against the received data at the Secondary Sample Point SSP. If a bit error is detected, the transmitter will react on this bit error at the next following regular sample point. During arbitration phase the delay compensation is always disabled.

The transmitter delay compensation enables configurations where the data bit time is shorter than the transmitter delay, it is described in detail in the new ISO11898-1. It is enabled by setting bit DBTP.TDC.

The received bit is compared against the transmitted bit at the SSP. The SSP position is defined as the sum of the measured delay from the CAN's transmit output CAN\_TX through the transceiver to the receive input CAN\_RX plus the transmitter delay compensation offset as configured by TDCR.TDCO. The transmitter delay compensation offset is used to adjust the position of the SSP inside the received bit (e.g. half of the bit time in the data phase). The position of the secondary sample point is rounded down to the next integer number of  $mtq$ .

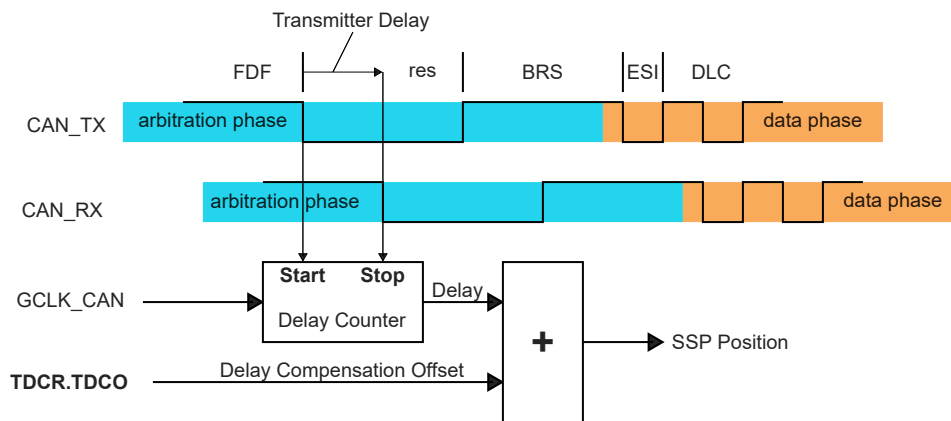
PSR.TDCV shows the actual transmitter delay compensation value. PSR.TDCV is cleared when CCCR.INIT is set and is updated at each transmission of an FD frame while DBTP.TDC is set.

The following boundary conditions have to be considered for the transmitter delay compensation implemented in the CAN:

- The sum of the measured delay from CAN\_TX to CAN\_RX and the configured transceiver delay compensation offset FBTP.TDCO has to be less than 6 bit times in the data phase.
- The sum of the measured delay from CAN\_TX to CAN\_RX and the configured transceiver delay compensation offset FBTP.TDCO has to be less or equal to 127 mtq. In case this sum exceeds 127 mtq, the maximum value of 127 mtq is used for transceiver delay compensation.
- The data phase ends at the sample point of the CRC delimiter, that stops checking of receive bits at the SSPs.  
Transmitter Delay Compensation Measurement

If transmitter delay compensation is enabled by programming DBTP.TDC = '1', the measurement is started within each transmitted CAN FD frame at the falling edge of bit FDF to bit res. The measurement is stopped when this edge is seen at the receive input CAN\_RX of the transmitter. The resolution of this measurement is one mtq.

**Figure 39-2. Transceiver delay measurement**



To avoid that a dominant glitch inside the received FDF bit ends the delay compensation measurement before the falling edge of the received res bit, resulting in a too early SSP position, the use of a transmitter delay compensation filter window can be enabled by programming TDCR.TDCF. This defines a minimum value for the SSP position. Dominant edges of CAN\_RX, that would result in an earlier SSP position are ignored for transmitter delay measurement. The measurement is stopped when the SSP position is at least TDCR.TDCF AND CAN\_RX is low.

### 39.6.2.5 Restricted Operation Mode

In Restricted Operation Mode the node is able to receive data and remote frames and to give acknowledge to valid frames, but it does not send data frames, remote frames, active error frames, or overload frames. In case of an error condition or overload condition, it does not send dominant bits, instead it waits for the occurrence of bus idle condition to resynchronize itself to the CAN communication. The error counters (ECR.REC, ECR.TEC) are frozen while Error Logging (ECR.CEL) is still incremented. The CPU can set the CAN into Restricted Operation mode by setting bit CCCR.ASM. The bit can only be set by the CPU when both CCCR.CCE and CCCR.INIT are set to '1'. The bit can be reset by the CPU at any time.

Restricted Operation Mode is automatically entered when the Tx Handler was not able to read data from the Message RAM in time. To leave Restricted Operation Mode, the CPU has to reset CCCR.ASM.

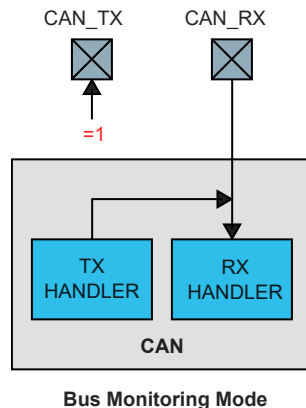
The Restricted Operation Mode can be used in applications that adapt themselves to different CAN bit rates. In this case the application tests different bit rates and leaves the Restricted Operation Mode after it has received a valid frame.

### 39.6.2.6 Bus Monitoring Mode

The CAN is set in Bus Monitoring Mode by programming CCCR.MON to '1'. In Bus Monitoring Mode (see ISO 11898-1, 10.12 Bus monitoring), the CAN is able to receive valid data frames and valid remote frames, but cannot start a transmission. In this mode, it sends only recessive bits on the CAN bus. If the CAN is required to send a dominant bit (ACK bit, overload flag, active error flag), the bit is rerouted internally so that the CAN monitors this dominant bit, although the CAN bus may remain in recessive state. In Bus Monitoring Mode register TXBRP is held in reset state.

The Bus Monitoring Mode can be used to analyze the traffic on a CAN bus without affecting it by the transmission of dominant bits. The figure below shows the connection of signals CAN\_TX and CAN\_RX to the CAN in Bus Monitoring Mode.

**Figure 39-3. Pin Control in Bus Monitoring Mode**



### 39.6.2.7 Disabled Automatic Retransmission

According to the CAN Specification (see ISO 11898-1, 6.3.3 Recovery Management), the CAN provides means for automatic retransmission of frames that have lost arbitration or that have been disturbed by errors during transmission. By default automatic retransmission is enabled. To support time-triggered communication as described in ISO 11898-1, chapter 9.2, the automatic retransmission may be disabled via CCCR.DAR.

#### Frame Transmission in DAR Mode

In DAR mode all transmissions are automatically cancelled after they started on the CAN bus. A Tx Buffer's Tx Request Pending bit TXBRP.TRPx is reset after successful transmission, when a transmission has not yet been started at the point of cancellation, has been aborted due to lost arbitration, or when an error occurred during frame transmission.

- Successful transmission:
  - Corresponding Tx Buffer Transmission Occurred bit TXBTO.TOx set
  - Corresponding Tx Buffer Cancellation Finished bit TXBCF.CFx not set
- Successful transmission in spite of cancellation:
  - Corresponding Tx Buffer Transmission Occurred bit TXBTO.TOx set
  - Corresponding Tx Buffer Cancellation Finished bit TXBCF.CFx set
- Arbitration lost or frame transmission disturbed:
  - Corresponding Tx Buffer Transmission Occurred bit TXBTO.TOx not set
  - Corresponding Tx Buffer Cancellation Finished bit TXBCF.CFx set

In case of a successful frame transmission, and if storage of Tx events is enabled, a Tx Event FIFO element is written with Event Type ET = "10" (transmission in spite of cancellation).

### 39.6.2.8 Test Modes

To enable write access to register TEST, bit CCCR.TEST has to be set to '1'. This allows the configuration of the test modes and test functions.

Four output functions are available for the CAN transmit pin CAN\_TX by programming TEST.TX. Additionally to its default function – the serial data output – it can drive the CAN Sample Point signal to monitor the CAN's bit timing and it can drive constant dominant or recessive values. The actual value at pin CAN\_RX can be read from TEST.RX. Both functions can be used to check the CAN bus' physical layer.

Due to the synchronization mechanism between GCLK\_CAN and GCLK\_CAN\_APB domains, there may be a delay of several GCLK\_CAN\_APB periods between writing to TEST.TX until the new configuration is visible at output pin CAN\_TX. This applies also when reading input pin CAN\_RX via TEST.RX.

Note: Test modes should be used for production tests or self test only. The software control for pin CAN\_TX interferes with all CAN protocol functions. It is not recommended to use test modes for application.

#### External Loop Back Mode

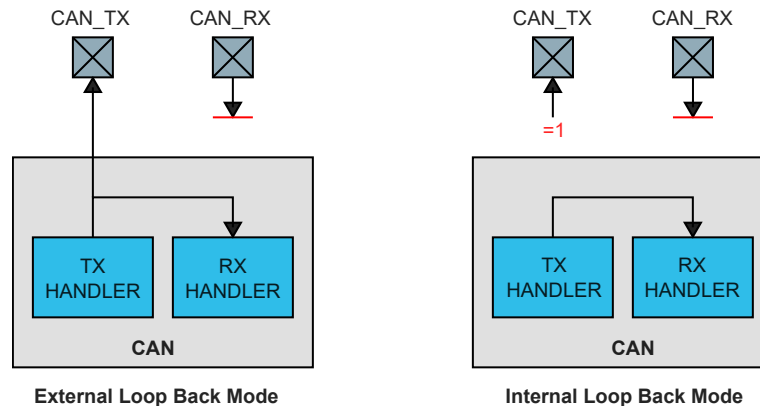
The CAN can be set in External Loop Back Mode by programming TEST.LBCK to '1'. In Loop Back Mode, the CAN treats its own transmitted messages as received messages and stores them (if they pass acceptance filtering) into an Rx Buffer or an Rx FIFO. The figure below shows the connection of signals CAN\_TX and CAN\_RX to the CAN in External Loop Back Mode.

This mode is provided for hardware self-test. To be independent from external stimulation, the CAN ignores acknowledge errors (recessive bit sampled in the acknowledge slot of a data/remote frame) in Loop Back Mode. In this mode the CAN performs an internal feedback from its Tx output to its Rx input. The actual value of the CAN\_RX input pin is disregarded by the CAN. The transmitted messages can be monitored at the CAN\_TX pin.

#### Internal Loop Back Mode

Internal Loop Back Mode is entered by programming bits TEST.LBCK and CCCR.MON to '1'. This mode can be used for a "Hot Selftest", meaning the CAN can be tested without affecting a running CAN system connected to the pins CAN\_TX and CAN\_RX. In this mode pin CAN\_RX is disconnected from the CAN and pin CAN\_TX is held recessive. The figure below shows the connection of CAN\_TX and CAN\_RX to the CAN in case of Internal Loop Back Mode.

**Figure 39-4. Pin Control in Loop Back Modes**



### 39.6.3 Timestamp Generation

For timestamp generation the CAN supplies a 16-bit wrap-around counter. A prescaler TSCC.TCP can be configured to clock the counter in multiples of CAN bit times (1...16). The counter is readable via TSCV.TSC. A write access to register TSCV resets the counter to zero. When the timestamp counter wraps around interrupt flag IR.TSW is set.

On start of frame reception / transmission the counter value is captured and stored into the timestamp section of an Rx Buffer / Rx FIFO (RXTS[15:0]) or Tx Event FIFO (TXTS[15:0]) element.

### 39.6.4 Timeout Counter

To signal timeout conditions for Rx FIFO 0, Rx FIFO 1, and the Tx Event FIFO the CAN supplies a 16-bit Timeout Counter. It operates as down-counter and uses the same prescaler controlled by TSCC.TCP as the Timestamp Counter. The Timeout Counter is configured via register TOCC. The actual counter value can be read from TOCV.TOC. The Timeout Counter can only be started while CCCR.INIT = '0'. It is stopped when CCCR.INIT = '1', e.g. when the CAN enters Bus\_Off state.

The operation mode is selected by TOCC.TOS. When operating in Continuous Mode, the counter starts when CCCR.INIT is reset. A write to TOCV presets the counter to the value configured by TOCC.TOP and continues down-counting.

When the Timeout Counter is controlled by one of the FIFOs, an empty FIFO presets the counter to the value configured by TOCC.TOP. Down-counting is started when the first FIFO element is stored. Writing to TOCV has no effect.

When the counter reaches zero, interrupt flag IR.TOO is set. In Continuous Mode, the counter is immediately restarted at TOCC.TOP.

Note: The clock signal for the Timeout Counter is derived from the CAN Core's sample point signal. Therefore the point in time where the Timeout Counter is decremented may vary due to the synchronization / re-synchronization mechanism of the CAN Core. If the baud rate switch feature in CAN FD is used, the timeout counter is clocked differently in arbitration and data field.

### 39.6.5 Rx Handling

The Rx Handler controls the acceptance filtering, the transfer of received messages to the Rx Buffers or to one of the two Rx FIFOs, as well as the Rx FIFO's Put and Get Indices.

### 39.6.5.1 Acceptance Filtering

The CAN offers the possibility to configure two sets of acceptance filters, one for standard identifiers and one for extended identifiers. These filters can be assigned to an Rx Buffer or to Rx FIFO 0,1. For acceptance filtering each list of filters is executed from element #0 until the first matching element. Acceptance filtering stops at the first matching element. The following filter elements are not evaluated for this message.

The main features are:

- Each filter element can be configured as
  - range filter (from - to)
  - filter for one or two dedicated IDs
  - classic bit mask filter
- Each filter element is configurable for acceptance or rejection filtering
- Each filter element can be enabled / disabled individually
- Filters are checked sequentially, execution stops with the first matching filter element

Related configuration registers are:

- Global Filter Configuration GFC
- Standard ID Filter Configuration SIDFC
- Extended ID Filter Configuration XIDFC
- Extended ID AND Mask XIDAM

Depending on the configuration of the filter element (SFEC/EFEC) a match triggers one of the following actions:

- Store received frame in FIFO 0 or FIFO 1
- Store received frame in Rx Buffer
- Store received frame in Rx Buffer and generate pulse at filter event pin
- Reject received frame
- Set High Priority Message interrupt flag IR.HPM
- Set High Priority Message interrupt flag IR.HPM and store received frame in FIFO 0 or FIFO 1

Acceptance filtering is started after the complete identifier has been received. After acceptance filtering has completed, and if a matching Rx Buffer or Rx FIFO has been found, the Message Handler starts writing the received message data in portions of 32 bit to the matching Rx Buffer or Rx FIFO. If the CAN protocol controller has detected an error condition (e.g. CRC error), this message is discarded with the following impact on the affected Rx Buffer or Rx FIFO:

#### Rx Buffer

New Data flag of matching Rx Buffer is not set, but Rx Buffer (partly) overwritten with received data. For error type see PSR.LEC respectively PSR.FLEC.

#### Rx FIFO

Put index of matching Rx FIFO is not updated, but related Rx FIFO element (partly) overwritten with received data. For error type see PSR.LEC respectively PSR.FLEC. In case the matching Rx FIFO is operated in overwrite mode, the boundary conditions described in [Rx FIFO Overwrite Mode](#) have to be considered.

Note: When an accepted message is written to one of the two Rx FIFOs, or into an Rx Buffer, the unmodified received identifier is stored independent of the filter(s) used. The result of the acceptance filter process is strongly depending on the sequence of configured filter elements.

### Range Filter

The filter matches for all received frames with Message IDs in the range defined by SF1ID/SF2ID for standard frames or EF1ID/EF2ID for extended frames.

There are two possibilities when range filtering is used together with extended frames:

**EFT = “00”** The Message ID of received frames is AND’ed with the Extended ID AND Mask (XIDAM) before the range filter is applied

**EFT = “11”** The Extended ID AND Mask (XIDAM) is not used for range filtering

### Filter for specific IDs

A filter element can be configured to filter for one or two specific Message IDs. To filter for one specific Message ID, the filter element has to be configured with SF1ID = SF2ID resp. EF1ID = EF2ID.

### Classic Bit Mask Filter

Classic bit mask filtering is intended to filter groups of Message IDs by masking single bits of a received Message ID. With classic bit mask filtering SF1ID/EF1ID is used as Message ID filter, while SF2ID/EF2ID is used as filter mask.

A zero bit at the filter mask will mask out the corresponding bit position of the configured ID filter, e.g. the value of the received Message ID at that bit position is not relevant for acceptance filtering. Only those bits of the received Message ID where the corresponding mask bits are one are relevant for acceptance filtering.

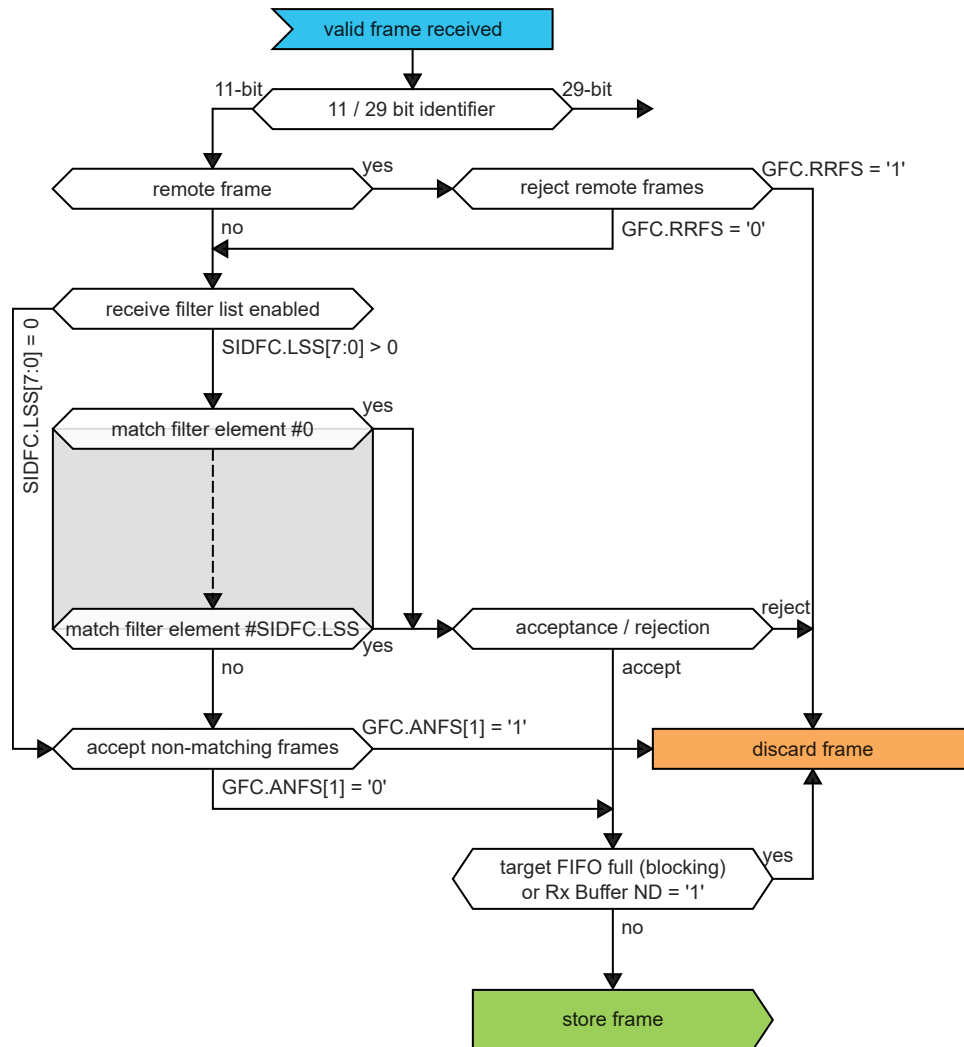
In case all mask bits are one, a match occurs only when the received Message ID and the Message ID filter are identical. If all mask bits are zero, all Message IDs match.

### Standard Message ID Filtering

The figure below shows the flow for standard Message ID (11-bit Identifier) filtering. The Standard Message ID Filter element is described in [39.9.5 Standard Message ID Filter Element](#).

Controlled by the Global Filter Configuration GFC and the Standard ID Filter Configuration SIDFC Message ID, Remote Transmission Request bit (RTR), and the Identifier Extension bit (IDE) of received frames are compared against the list of configured filter elements.

**Figure 39-5. Standard Message ID Filtering**



### Extended Message ID Filtering

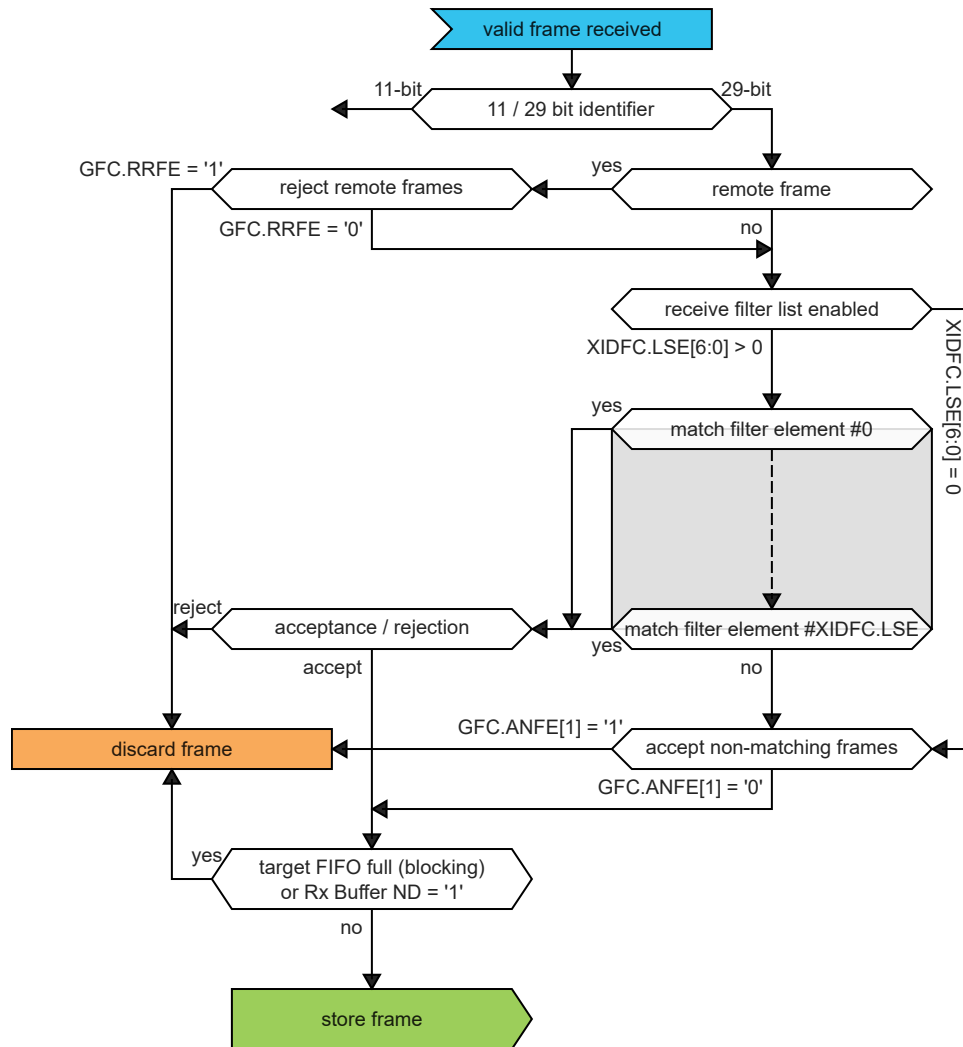
The figure below shows the flow for extended Message ID (29-bit Identifier) filtering. The Extended Message ID Filter element is described in [39.9.6 Extended Message ID Filter Element](#).

Controlled by the Global Filter Configuration GFC and the Extended ID Filter Configuration XIDFC Message ID, Remote Transmission Request bit (RTR), and the Identifier Extension bit (IDE) of received frames are compared against the list of configured filter elements.

The Extended ID AND Mask XIDAM is AND'ed with the received identifier before the filter list is executed.



**Figure 39-6. Extended Message ID Filtering**



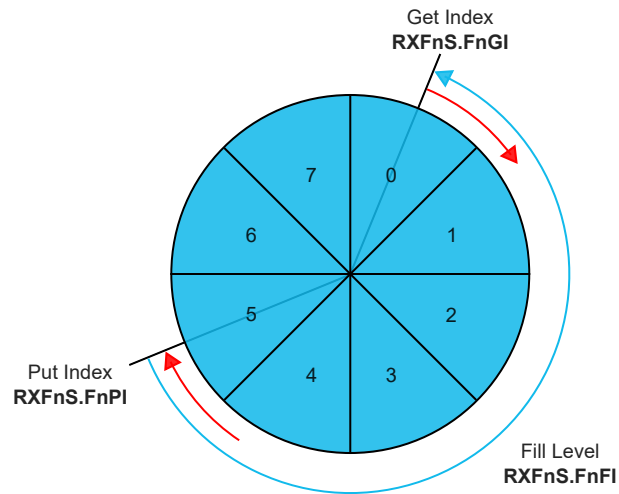
### 39.6.5.2 Rx FIFOs

Rx FIFO 0 and Rx FIFO 1 can be configured to hold up to 64 elements each. Configuration of the two Rx FIFOs is done via registers RXF0C and RXF1C.

Received messages that passed acceptance filtering are transferred to the Rx FIFO as configured by the matching filter element. For a description of the filter mechanisms available for Rx FIFO 0 and Rx FIFO 1 see [39.6.5.1 Acceptance Filtering](#). The Rx FIFO element is described in [39.9.2 Rx Buffer and FIFO Element](#).

To avoid an Rx FIFO overflow, the Rx FIFO watermark can be used. When the Rx FIFO fill level reaches the Rx FIFO watermark configured by RXFnC.FnWM, interrupt flag IR.RFnW is set. When the Rx FIFO Put Index reaches the Rx FIFO Get Index an Rx FIFO Full condition is signalled by RXFnS.FnF. In addition interrupt flag IR.RFnF is set.

**Figure 39-7. Rx FIFO Status**



When reading from an Rx FIFO, Rx FIFO Get Index  $RXFnS.FnGI \cdot \text{FIFO Element Size}$  has to be added to the corresponding Rx FIFO start address  $RXFnC.FnSA$ .

**Table 39-3. Rx Buffer / FIFO Element Size**

$RXESC.RBDS[2:0]$ $RXESC.FnDS[2:0]$	Data Field [bytes]	FIFO Element Size [RAM words]
000	8	4
001	12	5
010	16	6
011	20	7
100	24	8
101	32	10
110	48	14
111	64	18

### Rx FIFO Blocking Mode

The Rx FIFO blocking mode is configured by  $RXFnC.FnOM = '0'$ . This is the default operation mode for the Rx FIFOs.

When an Rx FIFO full condition is reached ( $RXFnS.FnPI = RXFnS.FnGI$ ), no further messages are written to the corresponding Rx FIFO until at least one message has been read out and the Rx FIFO Get Index has been incremented. An Rx FIFO full condition is signaled by  $RXFnS.FnF = '1'$ . In addition interrupt flag  $IR.RFnF$  is set.

In case a message is received while the corresponding Rx FIFO is full, this message is discarded and the message lost condition is signalled by  $RXFnS.RFnL = '1'$ . In addition interrupt flag  $IR.RFnL$  is set.

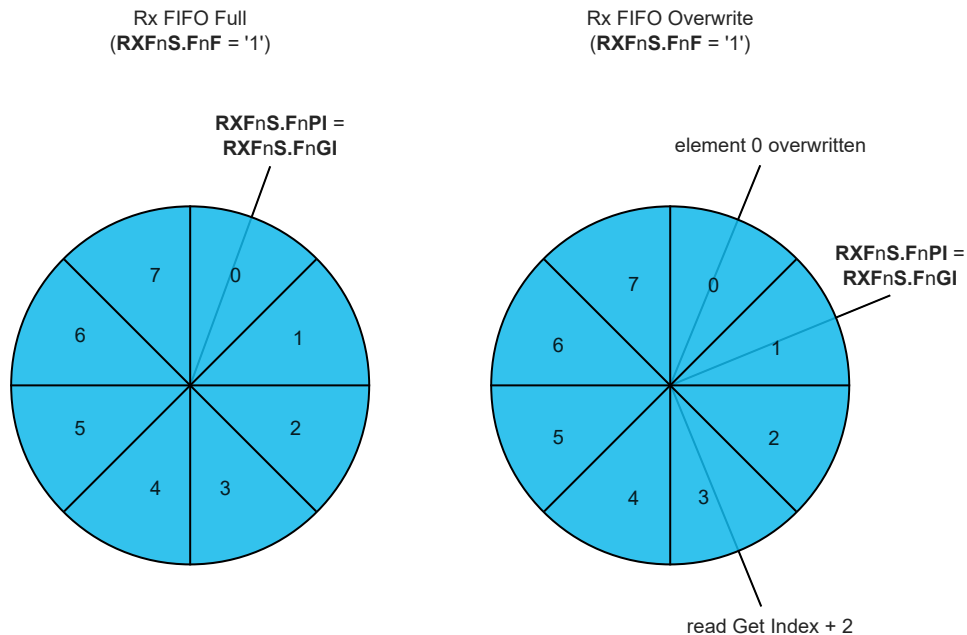
### Rx FIFO Overwrite Mode

The Rx FIFO overwrite mode is configured by  $RXFnC.FnOM = '1'$ .

When an Rx FIFO full condition ( $RXFnS.FnPI = RXFnS.FnGI$ ) is signaled by  $RXFnS.FnF = '1'$ , the next message accepted for the FIFO will overwrite the oldest FIFO message. Put and get index are both incremented by one.

When an Rx FIFO is operated in overwrite mode and an Rx FIFO full condition is signaled, reading of the Rx FIFO elements should start at least at get index + 1. The reason for that is, that it might happen, that a received message is written to the Message RAM (put index) while the CPU is reading from the Message RAM (get index). In this case inconsistent data may be read from the respective Rx FIFO element. Adding an offset to the get index when reading from the Rx FIFO avoids this problem. The offset depends on how fast the CPU accesses the Rx FIFO. The figure below shows an offset of two with respect to the get index when reading the Rx FIFO. In this case the two messages stored in element 1 and 2 are lost.

**Figure 39-8. Rx FIFO Overflow Handling**



After reading from the Rx FIFO, the number of the last element read has to be written to the Rx FIFO Acknowledge Index  $RXFnA.FnA$ . This increments the get index to that element number. In case the put index has not been incremented to this Rx FIFO element, the Rx FIFO full condition is reset ( $RXFnS.FnF = '0'$ ).

### 39.6.5.3 Dedicated Rx Buffers

The CAN supports up to 64 dedicated Rx Buffers. The start address of the dedicated Rx Buffer section is configured via  $RXBC.RBSA$ .

For each Rx Buffer a Standard or Extended Message ID Filter Element with  $SFEC / EFEC = "111"$  and  $SFID2 / EFID2[10:9] = "00"$  has to be configured (see [39.9.5 Standard Message ID Filter Element](#) and [39.9.6 Extended Message ID Filter Element](#)).

After a received message has been accepted by a filter element, the message is stored into the Rx Buffer in the Message RAM referenced by the filter element. The format is the same as for an Rx FIFO element. In addition the flag  $IR.DRX$  (Message stored in Dedicated Rx Buffer) in the interrupt register is set.

**Table 39-4. Example Filter Configuration for Rx Buffers**

Filter Element	SFID1[10:0] / EFID1[28:0]	SFID2[10:9] / EFID2[10:9]	SFID2[5:0] / EFID2[5:0]
0	ID message 1	00	00 0000
1	ID message 2	00	00 0001
2	ID message 3	00	00 0010

After the last word of a matching received message has been written to the Message RAM, the respective New Data flag in register NDAT1, NDAT2 is set. As long as the New Data flag is set, the respective Rx Buffer is locked against updates from received matching frames. The New Data flags have to be reset by the CPU by writing a '1' to the respective bit position.

While an Rx Buffer's New Data flag is set, a Message ID Filter Element referencing this specific Rx Buffer will not match, causing the acceptance filtering to continue. Following Message ID Filter Elements may cause the received message to be stored into another Rx Buffer, or into an Rx FIFO, or the message may be rejected, depending on filter configuration.

### Rx Buffer Handling

- Reset interrupt flag IR.DRX
- Read New Data registers
- Read messages from Message RAM
- Reset New Data flags of processed messages

#### 39.6.5.4 Debug on CAN Support

Debug messages are stored into Rx Buffers. For debug handling three consecutive Rx buffers (e.g. #61, #62, #63) have to be used for storage of debug messages A, B, and C. The format is the same as for an Rx Buffer or an Rx FIFO element (see [39.9.2 Rx Buffer and FIFO Element](#)).

Advantage: Fixed start address for the DMA transfers (relative to RXBC.RBSA), no additional configuration required.

For filtering of debug messages Standard / Extended Filter Elements with SFEC / EFEC = "111" have to be set up. Messages matching these filter elements are stored into the Rx Buffers addressed by SFID2 / EFID2[5:0].

After message C has been stored, the DMA request output is activated and the three messages can be read from the Message RAM under DMA control. The RAM words holding the debug messages will not be changed by the CAN while DMA request is activated. The behavior is similar to that of an Rx Buffers with its New Data flag set.

After the DMA has completed the DMA unit sets the DMA acknowledge. This resets DMA request. Now the CAN is prepared to receive the next set of debug messages.

### Filtering for Debug Messages

Filtering for debug messages is done by configuring one Standard / Extended Message ID Filter Element for each of the three debug messages. To enable a filter element to filter for debug messages SFEC / EFEC has to be programmed to "111". In this case fields SFID1 / SFID2 and EFID1 / EFID2 have a different meaning (see [39.9.5 Standard Message ID Filter Element](#) and [39.9.6 Extended Message ID Filter Element](#)). While SFID2 / EFID2[10:9] controls the debug message handling state machine, SFID2 / EFID2[5:0] controls the location for storage of a received debug message.

When a debug message is stored, neither the respective New Data flag nor IR.DRX are set. The reception of debug messages can be monitored via RXF1S.DMS.

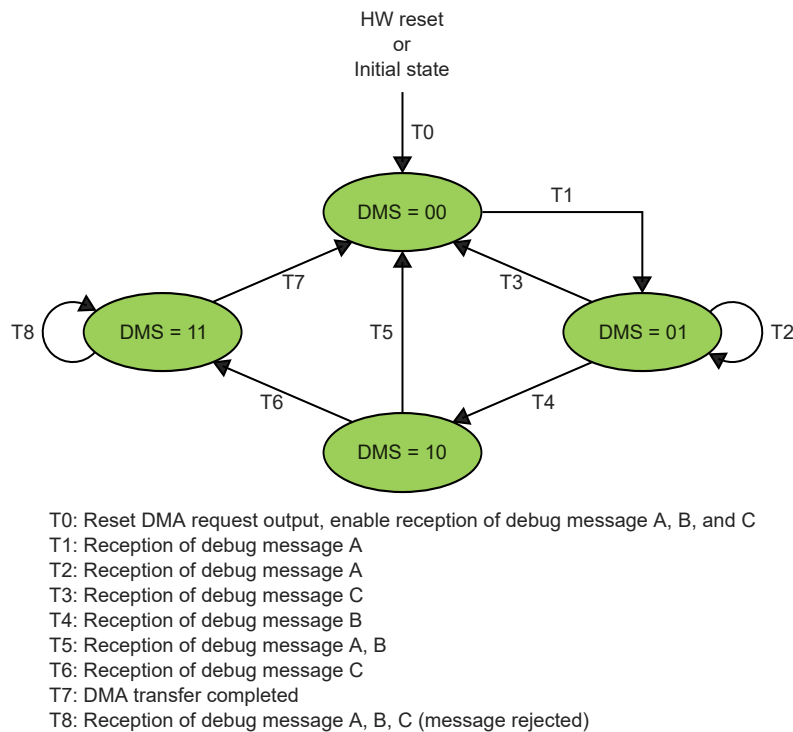
**Table 39-5. Example Filter Configuration for Debug Messages**

Filter Element	SFID1[10:0] / EFID1[28:0]	SFID2[10:9] / EFID2[10:9]	SFID2[5:0] / EFID2[5:0]
0	ID debug message A	01	11 1101
1	ID debug message B	10	11 1110
2	ID debug message C	11	11 1111

### Debug Message Handling

The debug message handling state machine assures that debug messages are stored to three consecutive Rx Buffers in correct order. In case of missing messages the process is restarted. The DMA request is activated only when all three debug messages A, B, C have been received in correct order.

**Figure 39-9. Debug Message Handling State Machine**



### 39.6.6 Tx Handling

The Tx Handler handles transmission requests for the dedicated Tx Buffers, the Tx FIFO, and the Tx Queue. It controls the transfer of transmit messages to the CAN Core, the Put and Get Indices, and the Tx Event FIFO. Up to 32 Tx Buffers can be set up for message transmission. The CAN mode for transmission (Classic CAN or CAN FD) can be configured separately for each Tx Buffer element. The Tx Buffer element is described in [39.9.3 Tx Buffer Element](#). The table below describes the possible configurations for frame transmission.

**Table 39-6. Possible Configurations for Frame Transmission**

CCCR		Tx Buffer Element		Frame Transmission
BRSE	FDOE	FDF	BRS	
ignored	0	ignored	ignored	Classic CAN
0	1	0	ignored	Classic CAN
0	1	1	ignored	FD without bit rate switching
1	1	0	ignored	Classic CAN
1	1	1	0	FD without bit rate switching
1	1	1	1	FD with bit rate switching

Note: AUTOSAR requires at least three Tx Queue Buffers and support of transmit cancellation

The Tx Handler starts a Tx scan to check for the highest priority pending Tx request (Tx Buffer with lowest Message ID) when the Tx Buffer Request Pending register TXBRP is updated, or when a transmission has been started.

### 39.6.6.1 Transmit Pause

The transmit pause feature is intended for use in CAN systems where the CAN message identifiers are (permanently) specified to specific values and cannot easily be changed. These message identifiers may have a higher CAN arbitration priority than other defined messages, while in a specific application their relative arbitration priority should be inverse. This may lead to a case where one ECU sends a burst of CAN messages that cause another ECU's CAN messages to be delayed because that other messages have a lower CAN arbitration priority.

If e.g. CAN ECU-1 has the transmit pause feature enabled and is requested by its application software to transmit four messages, it will, after the first successful message transmission, wait for two CAN bit times of bus idle before it is allowed to start the next requested message. If there are other ECUs with pending messages, those messages are started in the idle time, they would not need to arbitrate with the next message of ECU-1. After having received a message, ECU-1 is allowed to start its next transmission as soon as the received message releases the CAN bus.

The transmit pause feature is controlled by bit CCCR.TXP. If the bit is set, the CAN will, each time it has successfully transmitted a message, pause for two CAN bit times before starting the next transmission. This enables other CAN nodes in the network to transmit messages even if their messages have lower prior identifiers. Default is transmit pause disabled (CCCR.TXP = '0').

This feature looses up burst transmissions coming from a single node and it protects against "babbling idiot" scenarios where the application program erroneously requests too many transmissions.

### 39.6.6.2 Dedicated Tx Buffers

Dedicated Tx Buffers are intended for message transmission under complete control of the CPU. Each Dedicated Tx Buffer is configured with a specific Message ID. In case that multiple Tx Buffers are configured with the same Message ID, the Tx Buffer with the lowest buffer number is transmitted first.

If the data section has been updated, a transmission is requested by an Add Request via TXBAR.ARn. The requested messages arbitrate internally with messages from an optional Tx FIFO or Tx Queue and externally with messages on the CAN bus, and are sent out according to their Message ID.

A Dedicated Tx Buffer allocates Element Size 32-bit words in the Message RAM (refer to table below). Therefore the start address of a dedicated Tx Buffer in the Message RAM is calculated by adding transmit buffer index (0...31) • Element Size to the Tx Buffer Start Address TXBC.TBSA.

**Table 39-7. Tx Buffer / FIFO / Queue Element Size**

TXESC.TBDS[2:0]	Data Field [bytes]	Element Size [RAM words]
000	8	4
001	12	5
010	16	6
011	20	7
100	24	8
101	32	10
110	48	14
111	64	18

### 39.6.6.3 Tx FIFO

Tx FIFO operation is configured by programming TXBC.TFQM to '0'. Messages stored in the Tx FIFO are transmitted starting with the message referenced by the Get Index TXFQS.TFGI. After each transmission the Get Index is incremented cyclically until the Tx FIFO is empty. The Tx FIFO enables transmission of messages with the same Message ID from different Tx Buffers in the order these messages have been written to the Tx FIFO. The CAN calculates the Tx FIFO Free Level TXFQS.TFFL as difference between Get and Put Index. It indicates the number of available (free) Tx FIFO elements.

New transmit messages have to be written to the Tx FIFO starting with the Tx Buffer referenced by the Put Index TXFQS.TFQPI. An Add Request increments the Put Index to the next free Tx FIFO element. When the Put Index reaches the Get Index, Tx FIFO Full (TXFQS.TFQF = '1') is signaled. In this case no further messages should be written to the Tx FIFO until the next message has been transmitted and the Get Index has been incremented.

When a single message is added to the Tx FIFO, the transmission is requested by writing a '1' to the TXBAR bit related to the Tx Buffer referenced by the Tx FIFO's Put Index.

When multiple (n) messages are added to the Tx FIFO, they are written to n consecutive Tx Buffers starting with the Put Index. The transmissions are then requested via TXBAR. The Put Index is then cyclically incremented by n. The number of requested Tx buffers should not exceed the number of free Tx Buffers as indicated by the Tx FIFO Free Level.

When a transmission request for the Tx Buffer referenced by the Get Index is canceled, the Get Index is incremented to the next Tx Buffer with pending transmission request and the Tx FIFO Free Level is recalculated. When transmission cancellation is applied to any other Tx Buffer, the Get Index and the FIFO Free Level remain unchanged.

A Tx FIFO element allocates Element Size 32-bit words in the Message RAM (refer to [Table 39-7](#)). Therefore the start address of the next available (free) Tx FIFO Buffer is calculated by adding Tx FIFO/ Queue Put Index TXFQS.TFQPI (0...31) • Element Size to the Tx Buffer Start Address TXBC.TBSA.

### 39.6.6.4 Tx Queue

Tx Queue operation is configured by programming TXBC.TFQM to '1'. Messages stored in the Tx Queue are transmitted starting with the message with the lowest Message ID (highest priority). In case that

multiple Queue Buffers are configured with the same Message ID, the Queue Buffer with the lowest buffer number is transmitted first.

New messages have to be written to the Tx Buffer referenced by the Put Index TXFQS.TFQPI. An Add Request cyclically increments the Put Index to the next free Tx Buffer. In case that the Tx Queue is full (TXFQS.TFQF = '1'), the Put Index is not valid and no further message should be written to the Tx Queue until at least one of the requested messages has been sent out or a pending transmission request has been canceled.

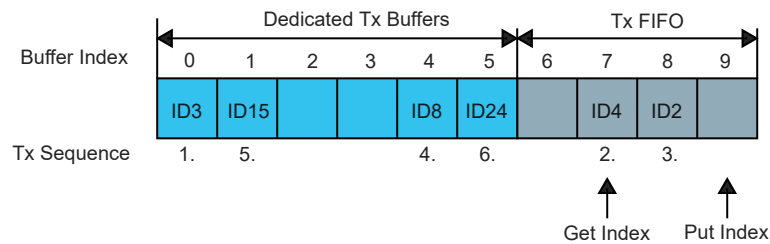
The application may use register TXBRP instead of the Put Index and may place messages to any Tx Buffer without pending transmission request.

A Tx Queue Buffer allocates Element Size 32-bit words in the Message RAM (refer to [Table 39-7](#)). Therefore the start address of the next available (free) Tx Queue Buffer is calculated by adding Tx FIFO/Queue Put Index TXFQS.TFQPI (0...31) • Element Size to the Tx Buffer Start Address TXBC.TBSA.

### 39.6.6.5 Mixed Dedicated Tx Buffers / Tx FIFO

In this case the Tx Buffers section in the Message RAM is subdivided into a set of Dedicated Tx Buffers and a Tx FIFO. The number of Dedicated Tx Buffers is configured by TXBC.NDTB. The number of Tx Buffers assigned to the Tx FIFO is configured by TXBC.TFQS. In case TXBC.TFQS is programmed to zero, only Dedicated Tx Buffers are used.

**Figure 39-10. Example of mixed Configuration Dedicated Tx Buffers / Tx FIFO**



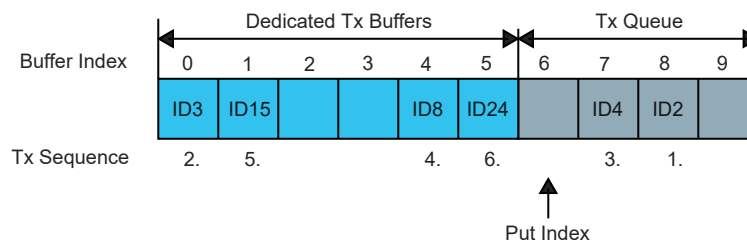
Tx prioritization:

- Scan Dedicated Tx Buffers and oldest pending Tx FIFO Buffer (referenced by TXFS.TFGI)
- Buffer with lowest Message ID gets highest priority and is transmitted next

### 39.6.6.6 Mixed Dedicated Tx Buffers / Tx Queue

In this case the Tx Buffers section in the Message RAM is subdivided into a set of Dedicated Tx Buffers and a Tx Queue. The number of Dedicated Tx Buffers is configured by TXBC.NDTB. The number of Tx Queue Buffers is configured by TXBC.TFQS. In case TXBC.TFQS is programmed to zero, only Dedicated Tx Buffers are used.

**Figure 39-11. Example of mixed Configuration Dedicated Tx Buffers / Tx Queue**



Tx prioritization:

- Scan all Tx Buffers with activated transmission request



- Tx Buffer with lowest Message ID gets highest priority and is transmitted next

### 39.6.6.7 Transmit Cancellation

The CAN supports transmit cancellation. This feature is especially intended for gateway applications and AUTOSAR based applications. To cancel a requested transmission from a dedicated Tx Buffer or a Tx Queue Buffer the CPU has to write a '1' to the corresponding bit position (=number of Tx Buffer) of register TXBCR. Transmit cancellation is not intended for Tx FIFO operation.

Successful cancellation is signaled by setting the corresponding bit of register TXBCF to '1'.

In case a transmit cancellation is requested while a transmission from a Tx Buffer is already ongoing, the corresponding TXBRP bit remains set as long as the transmission is in progress. If the transmission was successful, the corresponding TXBTO and TXBCF bits are set. If the transmission was not successful, it is not repeated and only the corresponding TXBCF bit is set.

**Note:** In case a pending transmission is canceled immediately before this transmission could have been started, there follows a short time window where no transmission is started even if another message is also pending in this node. This may enable another node to transmit a message which may have a lower priority than the second message in this node.

### 39.6.6.8 Tx Event Handling

To support Tx event handling the CAN has implemented a Tx Event FIFO. After the CAN has transmitted a message on the CAN bus, Message ID and timestamp are stored in a Tx Event FIFO element. To link a Tx event to a Tx Event FIFO element, the Message Marker from the transmitted Tx Buffer is copied into the Tx Event FIFO element.

The Tx Event FIFO can be configured to a maximum of 32 elements. The Tx Event FIFO element is described in [39.9.4 Tx Event FIFO Element](#).

When a Tx Event FIFO full condition is signaled by IR.TEFF, no further elements are written to the Tx Event FIFO until at least one element has been read out and the Tx Event FIFO Get Index has been incremented. In case a Tx event occurs while the Tx Event FIFO is full, this event is discarded and interrupt flag IR.TEFL is set.

To avoid a Tx Event FIFO overflow, the Tx Event FIFO watermark can be used. When the Tx Event FIFO fill level reaches the Tx Event FIFO watermark configured by TXEFC.EFWM, interrupt flag IR.TEFW is set.

When reading from the Tx Event FIFO, two times the Tx Event FIFO Get Index TXEFS.EFGI has to be added to the Tx Event FIFO start address TXEFC.EFSA.

### 39.6.7 FIFO Acknowledge Handling

The Get Indexes of Rx FIFO 0, Rx FIFO 1 and the Tx Event FIFO are controlled by writing to the corresponding FIFO Acknowledge Index (refer to [39.8.29 RXF0A](#), [39.8.33 RXF1A](#) and [39.8.47 TXEFA](#)). Writing to the FIFO Acknowledge Index will set the FIFO Get Index to the FIFO Acknowledge Index plus one and thereby updates the FIFO Fill Level. There are two use cases:

When only a single element has been read from the FIFO (the one being pointed to by the Get Index), this Get Index value is written to the FIFO Acknowledge Index.

When a sequence of elements has been read from the FIFO, it is sufficient to write the FIFO Acknowledge Index only once at the end of that read sequence (value: Index of the last element read), to update the FIFO's Get Index.

Due to the fact that the CPU has free access to the CAN's Message RAM, special care has to be taken when reading FIFO elements in an arbitrary order (Get Index not considered). This might be useful when

reading a High Priority Message from one of the two Rx FIFOs. In this case the FIFO's Acknowledge Index should not be written because this would set the Get Index to a wrong position and also alters the FIFO's Fill Level. In this case some of the older FIFO elements would be lost.

**Note:** The application has to ensure that a valid value is written to the FIFO Acknowledge Index. The CAN does not check for erroneous values.

### 39.6.8 Interrupts

The CAN has the following interrupt sources:

- Access to Reserved Address
- Protocol Errors (Data Phase / Arbitration Phase)
- Watchdog Interrupt
- Bus\_Off Status
- Error Warning & Passive
- Error Logging Overflow
- Message RAM Bit Errors (Uncorrected / Corrected)
- Message stored to Dedicated Rx Buffer
- Timeout Occurred
- Message RAM Access Failure
- Timestamp Wraparound
- Tx Event FIFO statuses (Element Lost / Full / Watermark Reached / New Entry)
- Tx FIFO Empty
- Transmission Cancellation Finished
- Timestamp Completed
- High Priority Message
- Rx FIFO 1 Statuses (Message Lost / Full / Watermark Reached / New Message)
- Rx FIFO 0 Statuses (Message Lost / Full / Watermark Reached / New Message)

Each interrupt source has an interrupt flag associated with it. The interrupt flag register (IR) is set when the interrupt condition occurs. Each interrupt can be individually enabled by writing '1' or disabled by writing '0' to the corresponding bit in the interrupt enable register (IE). Each interrupt flag can be assigned to one of two interrupt service lines.

An interrupt request is generated when an interrupt flag is set, the corresponding interrupt enable is set, and the corresponding service line enable assigned to the interrupt is set. The interrupt request remains active until the interrupt flag is cleared, the interrupt is disabled, the service line is disabled, or the CAN is reset. Refer to [39.8.16 IR](#) for details on how to clear interrupt flags. All interrupt requests from the peripheral are sent to the NVIC. The user must read the IR register to determine which interrupt condition is present.

Note that interrupts must be globally enabled for interrupt requests to be generated.

### 39.6.9 Sleep Mode Operation

The CAN can be configured to operate in any idle sleep mode. The CAN cannot operate in Standby sleep mode.

The CAN has its own low power mode that may be used at any time without disabling the CAN. It is also mandatory to allow the CAN to complete all pending transactions before entering standby by activating this low power mode. This is performed by writing one to the Clock Stop Request bit in the CC Control

register (CCCR.CSR = 1). Once all pending transactions are completed and the idle bus state is detected, the CAN will automatically set the Clock Stop Acknowledge bit (CCCR.CSA = 1). The CAN then reverts back to its initial state (CCCR.INIT = 1), blocking further transfers, and it is now safe for CLK\_CANx\_APB and GCLK\_CANx to be switched off and the system may go to standby.

To leave low power mode, CLK\_CANx\_APB and GCLK\_CANx must be active before writing CCCR.CSR to '0'. The CAN will acknowledge this by resetting CCCR.CSA = 0. Afterwards, the application can restart CAN communication by resetting bit CCCR.INIT.

### 39.6.10 Synchronization

Due to the asynchronicity between the main clock domain (CLK\_CAN\_APB) and the peripheral clock domain (GCLK\_CAN) some registers are synchronized when written. When a write-synchronized register is written, the read back value will not be updated until the register has completed synchronization.

The following bits and registers are write-synchronized:

I Initialization bit in CC Control register (CCCR.INIT)

# SAM D5x/E5x Family Data Sheet

## CAN - Control Area Network

### 39.7 Register Summary

Offset	Name	Bit Pos.									
0x00	CREL	7:0									
		15:8									
		23:16	SUBSTEP[3:0]								
		31:24	REL[3:0]			STEP[3:0]					
0x04	ENDN	7:0	ETV[7:0]								
		15:8	ETV[15:8]								
		23:16	ETV[23:16]								
		31:24	ETV[31:24]								
0x08	MRCFG	7:0						DQOS[1:0]			
		15:8									
		23:16									
		31:24									
0x0C	DBTP	7:0	DTSEG2[3:0]			DSJW[3:0]					
		15:8				DTSEG1[4:0]					
		23:16	TDC			DBRP[4:0]					
		31:24									
0x10	TEST	7:0	RX	TX[1:0]	LBCK						
		15:8									
		23:16									
		31:24									
0x14	RWD	7:0	WDC[7:0]								
		15:8	WDV[7:0]								
		23:16									
		31:24									
0x18	CCCR	7:0	TEST	DAR	MON	CSR	CSA	ASM	CCE	INIT	
		15:8		TXP	EFBI	PXHD			BRSE	FDOE	
		23:16									
		31:24									
0x1C	NBTP	7:0	NTSEG2[6:0]								
		15:8	NTSEG1[7:0]								
		23:16	NBRP[7:0]								
		31:24	NSJW[6:0]			NBRP[8:8]					
0x20	TSCC	7:0						TSS[1:0]			
		15:8									
		23:16	TCP[3:0]								
		31:24									
0x24	TSCV	7:0	TSC[7:0]								
		15:8	TSC[14:8]								
		23:16									
		31:24									

# SAM D5x/E5x Family Data Sheet

## CAN - Control Area Network

.....continued

Offset	Name	Bit Pos.										
0x28	TOCC	7:0						TOS[1:0]		ETOC		
		15:8										
		23:16	TOP[7:0]									
		31:24	TOP[15:8]									
0x2C	TOCV	7:0	TOC[7:0]									
		15:8	TOC[15:8]									
		23:16										
		31:24										
0x30 ... 0x3F	Reserved											
0x40	ECR	7:0	TEC[7:0]									
		15:8	RP	REC[6:0]								
		23:16	CEL[7:0]									
		31:24										
0x44	PSR	7:0	BO	EW	EP	ACT[1:0]			LEC[2:0]			
		15:8		PXE	RFDF	RBR5	RESI	DLEC[2:0]				
		23:16	TDCV[6:0]									
		31:24										
0x48	TDCR	7:0	TDCF[6:0]									
		15:8	TDCO[6:0]									
		23:16										
		31:24										
0x4C ... 0x4F	Reserved											
0x50	IR	7:0	RF1L	RF1F	RF1W	RF1N	RF0L	RF0F	RF0W	RF0N		
		15:8	TEFL	TEFF	TEFW	TEFN	TFE	TCF	TC	HPM		
		23:16	EP	ELO	BEU	BEC	DRX	TOO	MRAF	TSW		
		31:24			ARA	PED	PEA	WDI	BO	EW		
0x54	IE	7:0	RF1LE	RF1FE	RF1WE	RF1NE	RF0LE	RF0FE	RF0WE	RF0NE		
		15:8	TEFLE	TEFFE	TEFWE	TEFNE	TFEE	TCFE	TCE	HPME		
		23:16	EPE	ELOE	BEUE	BECE	DRXE	TOOE	MRAFE	TSWE		
		31:24			ARAE	PEDE	PEAE	WDIE	BOE	EWE		
0x58	ILS	7:0	RF1LL	RF1FL	RF1WL	RF1NL	RF0LL	RF0FL	RF0WL	RF0NL		
		15:8	TEFLL	TEFFL	TEFWL	TEFNL	TFEL	TCFL	TCL	HPML		
		23:16	EPL	ELOL	BEUL	BECL	DRXL	TOOL	MRAFL	TSWL		
		31:24			ARAL	PEDL	PEAL	WDIL	BOL	EWL		
0x5C	ILE	7:0	EINTn[1:0]									
		15:8										
		23:16										
		31:24										
0x60 ... 0x7F	Reserved											

# SAM D5x/E5x Family Data Sheet

## CAN - Control Area Network

.....continued

Offset	Name	Bit Pos.								
0x80	GFC	7:0			ANFS[1:0]		ANFE[1:0]		RRFS	RRFE
		15:8								
		23:16								
		31:24								
0x84	SIDFC	7:0	FLSSA[7:0]							
		15:8	FLSSA[15:8]							
		23:16	LSS[7:0]							
		31:24								
0x88	XIDFC	7:0	FLESA[7:0]							
		15:8	FLESA[15:8]							
		23:16		LSE[6:0]						
		31:24								
0x8C ... 0x8F	Reserved									
0x90	XIDAM	7:0	EIDM[7:0]							
		15:8	EIDM[15:8]							
		23:16	EIDM[23:16]							
		31:24		EIDM[28:24]						
0x94	HPMS	7:0	MSI[1:0]			BIDX[5:0]				
		15:8	FLST	FIDX[6:0]						
		23:16								
		31:24								
0x98	NDAT1	7:0	NDn[7:0]							
		15:8	NDn[15:8]							
		23:16	NDn[23:16]							
		31:24	NDn[31:24]							
0x9C	NDAT2	7:0	NDn[7:0]							
		15:8	NDn[15:8]							
		23:16	NDn[23:16]							
		31:24	NDn[31:24]							
0xA0	RXF0C	7:0	F0SA[7:0]							
		15:8	F0SA[15:8]							
		23:16		F0S[6:0]						
		31:24	F0OM	F0WM[6:0]						
0xA4	RXF0S	7:0	F0FL[6:0]							
		15:8		F0GI[5:0]						
		23:16		F0PI[5:0]						
		31:24							RF0L	F0F
0xA8	RXF0A	7:0	F0AI[5:0]							
		15:8								
		23:16								
		31:24								

# SAM D5x/E5x Family Data Sheet

## CAN - Control Area Network

.....continued

Offset	Name	Bit Pos.												
0xAC	RXBC	7:0	RBSA[7:0]											
		15:8	RBSA[15:8]											
		23:16												
		31:24												
0xB0	RXF1C	7:0	F1SA[7:0]											
		15:8	F1SA[15:8]											
		23:16			F1S[6:0]									
		31:24	F1OM		F1WM[6:0]									
0xB4	RXF1S	7:0			F1FL[6:0]									
		15:8			F1GI[5:0]									
		23:16			F1PI[5:0]									
		31:24	DMS[1:0]								RF1L	F1F		
0xB8	RXF1A	7:0			F1AI[5:0]									
		15:8												
		23:16												
		31:24												
0xBC	RXESC	7:0		F1DS[2:0]					F0DS[2:0]					
		15:8						RBDS[2:0]						
		23:16												
		31:24												
0xC0	TXBC	7:0	TBSA[7:0]											
		15:8	TBSA[15:8]											
		23:16			NDTB[5:0]									
		31:24		TFQM		TFQS[5:0]								
0xC4	TXFQS	7:0			TFFL[5:0]									
		15:8				TFGI[4:0]								
		23:16			TFQF	TFQPI[4:0]								
		31:24												
0xC8	TXESC	7:0					TBDS[2:0]							
		15:8												
		23:16												
		31:24												
0xCC	TXBRP	7:0	TRPn[7:0]											
		15:8	TRPn[15:8]											
		23:16	TRPn[23:16]											
		31:24	TRPn[31:24]											
0xD0	TXBAR	7:0	ARn[7:0]											
		15:8	ARn[15:8]											
		23:16	ARn[23:16]											
		31:24	ARn[31:24]											
0xD4	TXBCR	7:0	CRn[7:0]											
		15:8	CRn[15:8]											
		23:16	CRn[23:16]											
		31:24	CRn[31:24]											

# SAM D5x/E5x Family Data Sheet

## CAN - Control Area Network

.....continued											
Offset	Name	Bit Pos.									
0xD8	TXBTO	7:0	TOn[7:0]								
		15:8	TOn[15:8]								
		23:16	TOn[23:16]								
		31:24	TOn[31:24]								
0xDC	TXBCF	7:0	CFn[7:0]								
		15:8	CFn[15:8]								
		23:16	CFn[23:16]								
		31:24	CFn[31:24]								
0xE0	TXBTIE	7:0	TIEn[7:0]								
		15:8	TIEn[15:8]								
		23:16	TIEn[23:16]								
		31:24	TIEn[31:24]								
0xE4	TXBCIE	7:0	CFIEn[7:0]								
		15:8	CFIEn[15:8]								
		23:16	CFIEn[23:16]								
		31:24	CFIEn[31:24]								
0xE8 ... 0xEF	Reserved										
0xF0	TXEFC	7:0	EFSA[7:0]								
		15:8	EFSA[15:8]								
		23:16							EFS[5:0]		
		31:24							EFWM[5:0]		
0xF4	TXEFS	7:0							EFFL[4:0]		
		15:8							EFGL[4:0]		
		23:16							EFPI[4:0]		
		31:24								TEFL    EFF	
0xF8	TXEFA	7:0							EFAL[4:0]		
		15:8									
		23:16									
		31:24									

### 39.8 Register Description

Registers are 32 bits wide. Atomic 8-, 16- and 32-bit accesses are supported. In addition, the 8-bit quarters and 16-bit halves of a 32-bit register, and the 8-bit halves of a 16-bit register can be accessed directly.



# SAM D5x/E5x Family Data Sheet

## CAN - Control Area Network

### 39.8.1 Core Release

**Name:** CREL  
**Offset:** 0x00  
**Reset:** 0x32100000  
**Property:** Read-only

Bit	31	30	29	28	27	26	25	24
	REL[3:0]				STEP[3:0]			
Access	R	R	R	R	R	R	R	R
Reset	0	0	1	1	0	0	1	0
Bit	23	22	21	20	19	18	17	16
	SUBSTEP[3:0]							
Access	R	R	R	R				
Reset	0	0	0	1				
Bit	15	14	13	12	11	10	9	8
Access								
Reset								
Bit	7	6	5	4	3	2	1	0
Access								
Reset								

**Bits 31:28 – REL[3:0]** Core Release

One digit, BCD-coded.

**Bits 27:24 – STEP[3:0]** Step of Core Release

One digit, BCD-coded.

**Bits 23:20 – SUBSTEP[3:0]** Sub-step of Core Release

One digit, BCD-coded.

# SAM D5x/E5x Family Data Sheet

## CAN - Control Area Network

### 39.8.2 Endian

**Name:** ENDN  
**Offset:** 0x04  
**Reset:** 0x87654321  
**Property:** Read-only

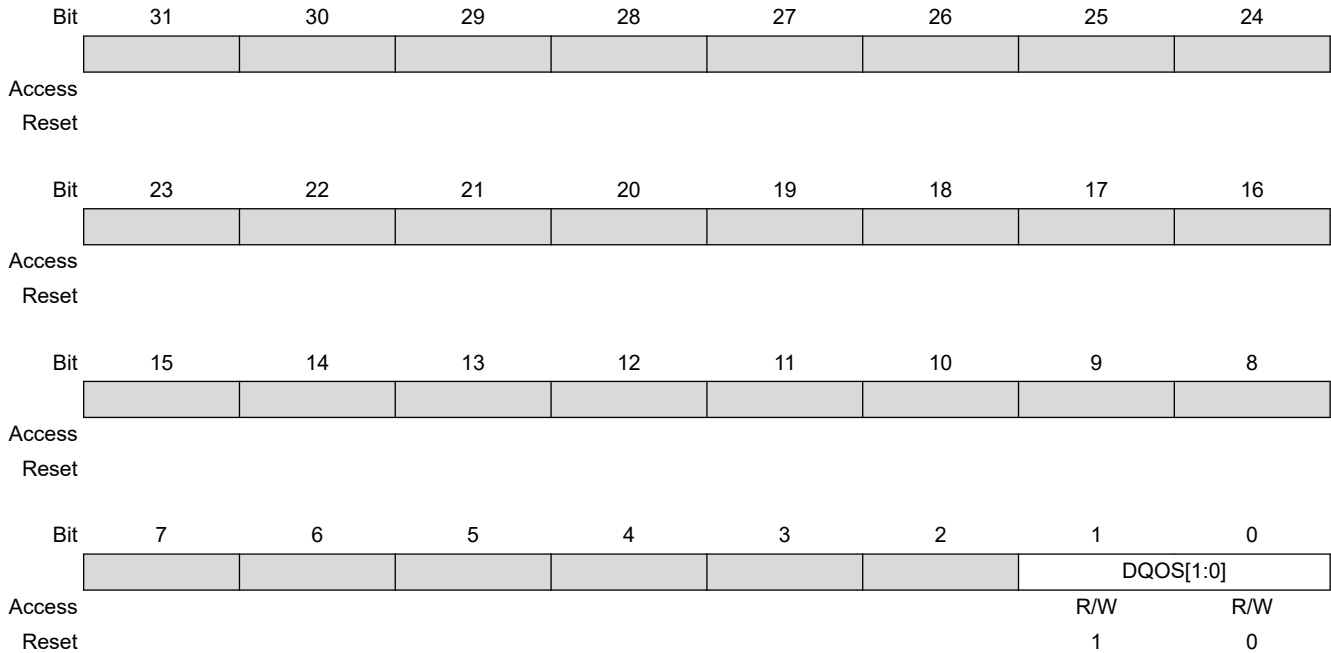
Bit	31	30	29	28	27	26	25	24
	ETV[31:24]							
Access	R	R	R	R	R	R	R	R
Reset	1	0	0	0	0	1	1	1
Bit	23	22	21	20	19	18	17	16
	ETV[23:16]							
Access	R	R	R	R	R	R	R	R
Reset	0	1	1	0	0	1	0	1
Bit	15	14	13	12	11	10	9	8
	ETV[15:8]							
Access	R	R	R	R	R	R	R	R
Reset	0	1	0	0	0	0	1	1
Bit	7	6	5	4	3	2	1	0
	ETV[7:0]							
Access	R	R	R	R	R	R	R	R
Reset	0	0	1	0	0	0	0	1

**Bits 31:0 – ETV[31:0]** Endianness Test Value

The endianness test value is 0x87654321

### 39.8.3 Message RAM Configuration

**Name:** MRCFG  
**Offset:** 0x08  
**Reset:** 0x00000002  
**Property:** -



#### Bits 1:0 – DQOS[1:0] Data Quality of Service

This field defines the memory priority access during the Message RAM read/write data operation.

Value	Name	Description
0x0	DISABLE	Background (no sensitive operation)
0x1	LOW	Sensitive bandwidth
0x2	MEDIUM	Sensitive latency
0x3	HIGH	Critical latency

# SAM D5x/E5x Family Data Sheet

## CAN - Control Area Network

### 39.8.4 Data Bit Timing and Prescaler

**Name:** DBTP  
**Offset:** 0x0C  
**Reset:** 0x00000A33  
**Property:** Write-restricted

This register is write-restricted and only writable if bit fields CCCR.CCE = 1 and CCCR.INIT = 1.

The CAN bit time may be programmed in the range of 4 to 49 time quanta. The CAN time quantum may be programmed in the range of 1 to 32 GCLK\_CAN periods.  $t_q = (DBRP + 1) mtq$ .

**Note:**

With a GCLK\_CAN of 8MHz, the reset value 0x00000A33 configures the CAN for a fast bit rate of 500 kBits/s.

The bit rate configured for the CAN FD data phase via DBTP must be higher or equal to the bit rate configured for the arbitration phase via NBTP.

	Bit	31	30	29	28	27	26	25	24
		[Greyed out bits 31-24]							
Access									
Reset									
	Bit	23	22	21	20	19	18	17	16
		TDC				DBRP[4:0]			
Access		R/W			R/W	R/W	R/W	R/W	R/W
Reset		0			0	0	0	0	0
	Bit	15	14	13	12	11	10	9	8
						DTSEG1[4:0]			
Access					R/W	R/W	R/W	R/W	R/W
Reset					0	1	0	1	0
	Bit	7	6	5	4	3	2	1	0
		DTSEG2[3:0]			DSJW[3:0]				
Access		R/W	R/W	R/W	R/W	R/W	R/W	R/W	R/W
Reset		0	0	1	1	0	0	1	1

**Bit 23 – TDC Transceiver Delay Compensation**

Value	Description
0	Transceiver Delay Compensation disabled.
1	Transceiver Delay Compensation enabled.

**Bits 20:16 – DBRP[4:0] Data Baud Rate Prescaler**

Value	Description
0x00 – 0x1F	The value by which the oscillator frequency is divided for generating the bit time quanta. The bit time is built up from a multiple of this quanta. Valid values for the Baud Rate Prescaler are 0 to 31. The actual interpretation by the hardware of this value is such that one more than the value programmed here is used.

# SAM D5x/E5x Family Data Sheet

## CAN - Control Area Network

---

---

**Bits 12:8 – DTSEG1[4:0]** Fast time segment before sample point

Value	Description
0x00 – 0x1F	Valid values are 0 to 31. The actual interpretation by the hardware of this value is such that one more than the programmed value is used. DTSEG1 is the sum of Prop_Seg and Phase_Seg1.

**Bits 7:4 – DTSEG2[3:0]** Data time segment after sample point

Value	Description
0x0 – 0xF	Valid values are 0 to 15. The actual interpretation by the hardware of this value is such that one more than the programmed value is used. DTSEG2 is Phase_Seg2.

**Bits 3:0 – DSJW[3:0]** Data (Re)Synchronization Jump Width

Value	Description
0x0 – 0xF	Valid values are 0 to 15. The actual interpretation by the hardware of this value is such that one more than the programmed value is used.

### 39.8.5 Test

**Name:** TEST  
**Offset:** 0x10  
**Reset:** 0x00000000  
**Property:** Read-only, Write-restricted

	Bit	31	30	29	28	27	26	25	24										
		<table border="1" style="width: 100%; height: 15px; border-collapse: collapse;"> <tr> <td style="width: 12.5%;"></td> <td style="width: 12.5%;"></td> <td style="width: 12.5%;"></td> <td style="width: 12.5%;"></td> <td style="width: 12.5%;"></td> <td style="width: 12.5%;"></td> <td style="width: 12.5%;"></td> <td style="width: 12.5%;"></td> <td style="width: 12.5%;"></td> <td style="width: 12.5%;"></td> </tr> </table>																	
Access																			
Reset																			
	Bit	23	22	21	20	19	18	17	16										
		<table border="1" style="width: 100%; height: 15px; border-collapse: collapse;"> <tr> <td style="width: 12.5%;"></td> <td style="width: 12.5%;"></td> <td style="width: 12.5%;"></td> <td style="width: 12.5%;"></td> <td style="width: 12.5%;"></td> <td style="width: 12.5%;"></td> <td style="width: 12.5%;"></td> <td style="width: 12.5%;"></td> <td style="width: 12.5%;"></td> <td style="width: 12.5%;"></td> </tr> </table>																	
Access																			
Reset																			
	Bit	15	14	13	12	11	10	9	8										
		<table border="1" style="width: 100%; height: 15px; border-collapse: collapse;"> <tr> <td style="width: 12.5%;"></td> <td style="width: 12.5%;"></td> <td style="width: 12.5%;"></td> <td style="width: 12.5%;"></td> <td style="width: 12.5%;"></td> <td style="width: 12.5%;"></td> <td style="width: 12.5%;"></td> <td style="width: 12.5%;"></td> <td style="width: 12.5%;"></td> <td style="width: 12.5%;"></td> </tr> </table>																	
Access																			
Reset																			
	Bit	7	6	5	4	3	2	1	0										
		RX	TX[1:0]		LBCK														
Access		R	R/W	R/W	R/W														
Reset		0	0	0	0														

#### Bit 7 – RX Receive Pin

Monitors the actual value of pin CAN\_RX

Value	Description
0	The CAN bus is dominant (CAN_RX = 0).
1	The CAN bus is recessive (CAN_RX = 1).

#### Bits 6:5 – TX[1:0] Control of Transmit Pin

This field defines the control of the transmit pin.

Value	Name	Description
0x0	CORE	Reset value, CAN_TX controlled by CAN core, updated at the end of CAN bit time.
0x1	SAMPLE	Sample Point can be monitored at pin CAN_TX.
0x2	DOMINANT	Dominant ('0') level at pin CAN_TX.
0x3	RECESSIVE	Recessive ('1') level at pin CAN_TX.

#### Bit 4 – LBCK Loop Back Mode

Value	Description
0	Loop Back Mode is disabled.
1	Loop Back Mode is enabled.

# SAM D5x/E5x Family Data Sheet

## CAN - Control Area Network

### 39.8.6 RAM Watchdog

**Name:** RWD  
**Offset:** 0x14  
**Reset:** 0x00000000  
**Property:** Read-only, Write-restricted

This register is write-restricted and only writable if bit fields CCCR.CCE = 1 and CCCR.INIT = 1.

The RAM Watchdog monitors the READY output of the Message RAM. A Message RAM access via the CAN's AHB Master Interface starts the Message RAM Watchdog Counter with the value configured by RWD.WDC. The counter is reloaded with RWD.WDC when the Message RAM signals successful completion by activating its READY output. In case there is no response from the Message RAM until the counter has counted down to zero, the counter stops and interrupt IR.WDI is set.

	31	30	29	28	27	26	25	24
Access								
Reset								
	23	22	21	20	19	18	17	16
Access								
Reset								
	15	14	13	12	11	10	9	8
	WDV[7:0]							
Access	R	R	R	R	R	R	R	R
Reset	0	0	0	0	0	0	0	0
	7	6	5	4	3	2	1	0
	WDC[7:0]							
Access	R	R	R	R	R	R	R	R
Reset	0	0	0	0	0	0	0	0

**Bits 15:8 – WDV[7:0]** Watchdog Value  
Actual Message RAM Watchdog Counter Value.

**Bits 7:0 – WDC[7:0]** Watchdog Configuration  
Start value of the Message RAM Watchdog Counter. With the reset value of 0x00 the counter is disabled.

# SAM D5x/E5x Family Data Sheet

## CAN - Control Area Network

### 39.8.7 CC Control

**Name:** CCCR  
**Offset:** 0x18  
**Reset:** 0x00000001  
**Property:** Read-only, Write-restricted

	31	30	29	28	27	26	25	24	
Access									
Reset									
	23	22	21	20	19	18	17	16	
Access									
Reset									
	15	14	13	12	11	10	9	8	
			TXP	EFBI	PXHD			BRSE	FDOE
Access			R/W	R/W	R/W			R/W	R/W
Reset			0	0	0			0	0
	7	6	5	4	3	2	1	0	
	TEST	DAR	MON	CSR	CSA	ASM	CCE	INIT	
Access	R/W	R/W	R/W	R/W	R/W	R/W	R/W	R/W	
Reset	0	0	0	0	0	0	0	1	

#### Bit 14 – TXP Transmit Pause

This bit field is write-restricted and only writable if bit fields CCE = 1 and INIT = 1.

Value	Description
0	Transmit pause disabled.
1	Transmit pause enabled. The CAN pauses for two CAN bit times before starting the next transmission after itself has successfully transmitted a frame.

#### Bit 13 – EFBI Edge Filtering during Bus Integration

Value	Description
0	Edge filtering is disabled.
1	Two consecutive dominant tq required to detect an edge for hard synchronization.

#### Bit 12 – PXHD Protocol Exception Handling Disable

**Note:** When protocol exception handling is disabled, the CAN will transmit an error frame when it detects a protocol exception condition.

Value	Description
0	Protocol exception handling enabled.
1	Protocol exception handling disabled.

#### Bit 9 – BRSE Bit Rate Switch Enable

**Note:** When CAN FD operation is disabled FDOE = 0, BRSE is not evaluated.



# SAM D5x/E5x Family Data Sheet

## CAN - Control Area Network

Value	Description
0	Bit rate switching for transmissions disabled.
1	Bit rate switching for transmissions enabled.

### Bit 8 – FDOE FD Operation Enable

Value	Description
0	FD operation disabled.
1	FD operation enabled.

### Bit 7 – TEST Test Mode Enable

This bit field is write-restricted.

Writing a 0 to this field is always allowed.

Writing a 1 to this field is only allowed if bit fields CCE = 1 and INIT = 1.

Value	Description
0	Normal operation. Register TEST holds reset values.
1	Test Mode, write access to register TEST enabled.

### Bit 6 – DAR Disable Automatic Retransmission

This bit field is write-restricted and only writable if bit fields CCE = 1 and INIT = 1.

Value	Description
0	Automatic retransmission of messages not transmitted successfully enabled.
1	Automatic retransmission disabled.

### Bit 5 – MON Bus Monitoring Mode

This bit field is write-restricted.

Writing a 0 to this field is always allowed.

Writing a 1 to this field is only allowed if bit fields CCE = 1 and INIT = 1.

Value	Description
0	Bus Monitoring Mode is disabled.
1	Bus Monitoring Mode is enabled.

### Bit 4 – CSR Clock Stop Request

Value	Description
0	No clock stop is requested.
1	Clock stop requested. When clock stop is requested, first INIT and then CSA will be set after all pending transfer requests have been completed and the CAN bus reached idle.

### Bit 3 – CSA Clock Stop Acknowledge

Value	Description
0	No clock stop acknowledged.
1	CAN may be set in power down by stopping CLK_CAN_APB and GCLK_CAN.

### Bit 2 – ASM Restricted Operation Mode

This bit field is write-restricted.

Writing a 0 to this field is always allowed.

Writing a 1 to this field is only allowed if bit fields CCE = 1 and INIT = 1.

Value	Description
0	Normal CAN operation.
1	Restricted Operation Mode active.

# SAM D5x/E5x Family Data Sheet

## CAN - Control Area Network

---

**Bit 1 – CCE** Configuration Change Enable

This bit field is write-restricted and only writable if bit field INIT = 1.

Value	Description
0	The CPU has no write access to the protected configuration registers.
1	The CPU has write access to the protected configuration registers (while CCCR.INIT = 1).

**Bit 0 – INIT** Initialization

Due to the synchronization mechanism between the two clock domains, there may be a delay until the value written to INIT can be read back. The programmer has to assure that the previous value written to INIT has been accepted by reading INIT before setting INIT to a new value.

Value	Description
0	Normal Operation.
1	Initialization is started.

# SAM D5x/E5x Family Data Sheet

## CAN - Control Area Network

### 39.8.8 Nominal Bit Timing and Prescaler

**Name:** NBTP  
**Offset:** 0x1C  
**Reset:** 0x00000A33  
**Property:** Write-restricted

This register is write-restricted and only writable if bit fields CCCR.CCE = 1 and CCCR.INIT = 1.

The CAN bit time may be programmed in the range of 4 to 385 time quanta. The CAN time quantum may be programmed in the range of 1 to 512 GCLK\_CAN periods.  $t_q = (NBRP + 1) mtq$ .

**Note:** With a CAN clock (GCLK\_CAN) of 8MHz, the reset value 0x06000A03 configures the CAN for a bit rate of 500 kBits/s.

Bit	31	30	29	28	27	26	25	24
	NSJW[6:0]							NBRP[8:8]
Access	R/W	R/W	R/W	R/W	R/W	R/W	R/W	R/W
Reset	0	0	0	0	0	1	1	0
Bit	23	22	21	20	19	18	17	16
	NBRP[7:0]							
Access	R/W	R/W	R/W	R/W	R/W	R/W	R/W	R/W
Reset	0	0	0	0	0	0	0	0
Bit	15	14	13	12	11	10	9	8
	NTSEG1[7:0]							
Access	R/W	R/W	R/W	R/W	R/W	R/W	R/W	R/W
Reset	0	0	0	0	1	0	1	0
Bit	7	6	5	4	3	2	1	0
		NTSEG2[6:0]						
Access		R/W	R/W	R/W	R/W	R/W	R/W	R/W
Reset		0	0	0	0	0	1	1

#### Bits 31:25 – NSJW[6:0] Nominal (Re)Synchronization Jump Width

Value	Description
0x00 – 0x7F	Valid values are 0 to 127. The actual interpretation by the hardware of this value is such that one more than the programmed value is used.

#### Bits 24:16 – NBRP[8:0] Nominal Baud Rate Prescaler

Value	Description
0x000 – 0x1FF	The value by which the oscillator frequency is divided for generating the bit time quanta. The bit time is built up from a multiple of this quanta. Valid values for the Baud Rate Prescaler are 0 to 511. The actual interpretation by the hardware of this value is such that one more than the value programmed here is used.

#### Bits 15:8 – NTSEG1[7:0] Nominal Time segment before sample point

# SAM D5x/E5x Family Data Sheet

## CAN - Control Area Network

---

---

Value	Description
0x00 - 0x7F	Valid values are 1 to 255. The actual interpretation by the hardware of this value is such that one more than the programmed value is used. NTSEG1 is the sum of Prop_Seg and Phase_Seg1.

**Bits 6:0 – NTSEG2[6:0]** Time segment after sample point

Value	Description
0x00 - 0x7F	Valid values are 0 to 127. The actual interpretation by the hardware of this value is such that one more than the programmed value is used. NTSEG2 is Phase_Seg2.

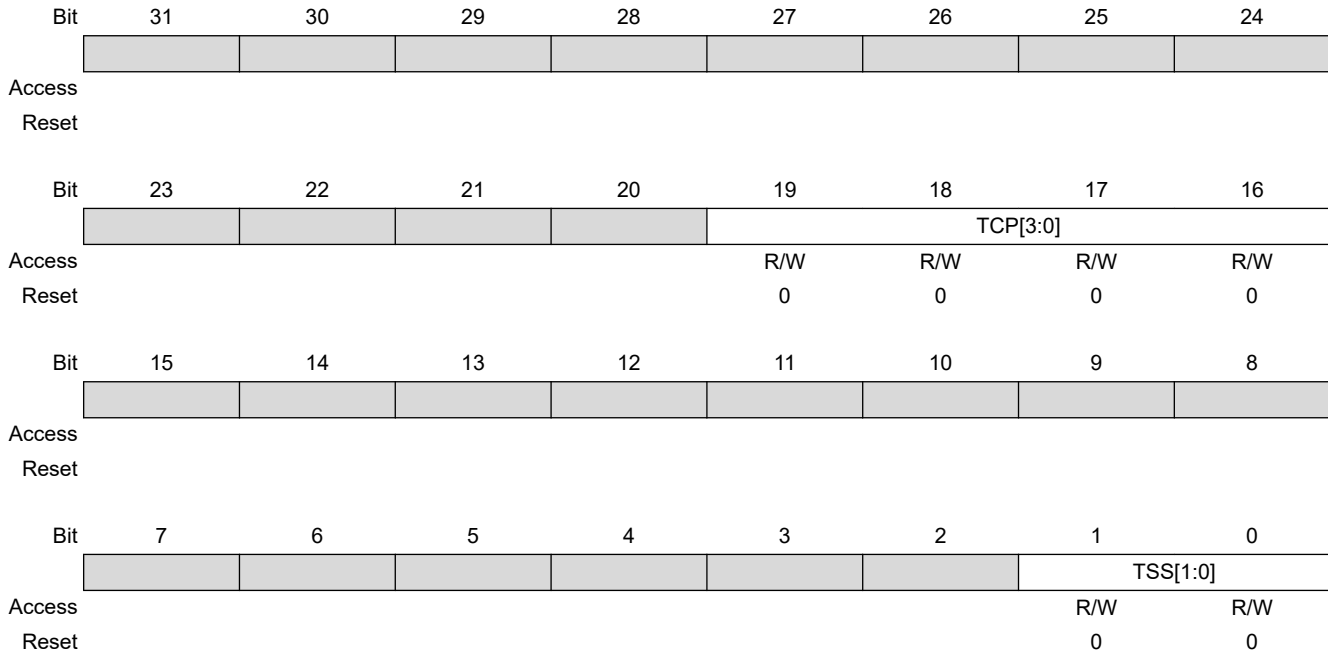
# SAM D5x/E5x Family Data Sheet

## CAN - Control Area Network

### 39.8.9 Timestamp Counter Configuration

**Name:** TSCC  
**Offset:** 0x20  
**Reset:** 0x00000000  
**Property:** Write-restricted

This register is write-restricted and only writable if bit fields CCCR.CCE = 1 and CCCR.INIT = 1.



#### Bits 19:16 – TCP[3:0] Timestamp Counter Prescaler

Value	Description
0x0 – 0xF	Configures the timestamp and timeout counters time unit in multiples of CAN bit times [1...16]. The actual interpretation by the hardware of this value is such that one more than the value programmed here is used.

#### Bits 1:0 – TSS[1:0] Timestamp Select

This field defines the timestamp counter selection.

Value	Name	Description
0x0 or 0x3	ZERO	Timestamp counter value always 0x0000.
0x1	INC	Timestamp counter value incremented by TCP.
0x2		

### 39.8.10 Timestamp Counter Value

**Name:** TSCV  
**Offset:** 0x24  
**Reset:** 0x00000000  
**Property:** Read-only

**Note:**

1. A write access to TSCV while in internal mode clears the Timestamp Counter value. A write access to TSCV while in external mode has no impact.
2. A “wrap around” is a change of the Timestamp Counter value from non-zero to zero not caused by the write access to TSCV.

	Bit	31	30	29	28	27	26	25	24
Access									
Reset									
	Bit	23	22	21	20	19	18	17	16
Access									
Reset									
	Bit	15	14	13	12	11	10	9	8
Access			R	R	R	R	R	R	R
Reset			0	0	0	0	0	0	0
	Bit	7	6	5	4	3	2	1	0
Access		R	R	R	R	R	R	R	R
Reset		0	0	0	0	0	0	0	0

**Bits 14:0 – TSC[14:0] Timestamp Counter**

The internal Timestamp Counter value is captured on start of frame (both Rx and Tx). When TSCC.TSS = 0x1, the Timestamp Counter is incremented in multiples of CAN bit times [1...16] depending on the configuration of TSCC.TCP. A wrap around sets interrupt flag IR.TSW.

# SAM D5x/E5x Family Data Sheet

## CAN - Control Area Network

### 39.8.11 Timeout Counter Configuration

**Name:** TOCC  
**Offset:** 0x28  
**Reset:** 0xFFFF0000  
**Property:** Write-restricted

This register is write-restricted and only writable if bit fields CCCR.CCE = 1 and CCCR.INIT = 1.

Bit	31	30	29	28	27	26	25	24
	TOP[15:8]							
Access	R/W	R/W	R/W	R/W	R/W	R/W	R/W	R/W
Reset	1	1	1	1	1	1	1	1
Bit	23	22	21	20	19	18	17	16
	TOP[7:0]							
Access	R/W	R/W	R/W	R/W	R/W	R/W	R/W	R/W
Reset	1	1	1	1	1	1	1	1
Bit	15	14	13	12	11	10	9	8
Access								
Reset								
Bit	7	6	5	4	3	2	1	0
						TOS[1:0]		ETOC
Access						R/W	R/W	R/W
Reset						0	0	0

#### Bits 31:16 – TOP[15:0] Timeout Period

Start value of the Timeout Counter (down-counter). Configures the Timeout Period.

#### Bits 2:1 – TOS[1:0] Timeout Select

When operating in Continuous mode, a write to TOCV presets the counter to the value configured by TOCC.TOP and continues down-counting. When the Timeout Counter is controlled by one of the FIFOs, an empty FIFO presets the counter to the value configured by TOCC.TOP. Down-counting is started when the first FIFO element is stored.

Value	Name	Description
0x0	CONT	Continuous operation.
0x1	TXEF	Timeout controlled by TX Event FIFO.
0x2	RXF0	Timeout controlled by Rx FIFO 0.
0x3	RXF1	Timeout controlled by Rx FIFO 1.

#### Bit 0 – ETOC Enable Timeout Counter

Value	Description
0	Timeout Counter disabled.
1	Timeout Counter enabled.

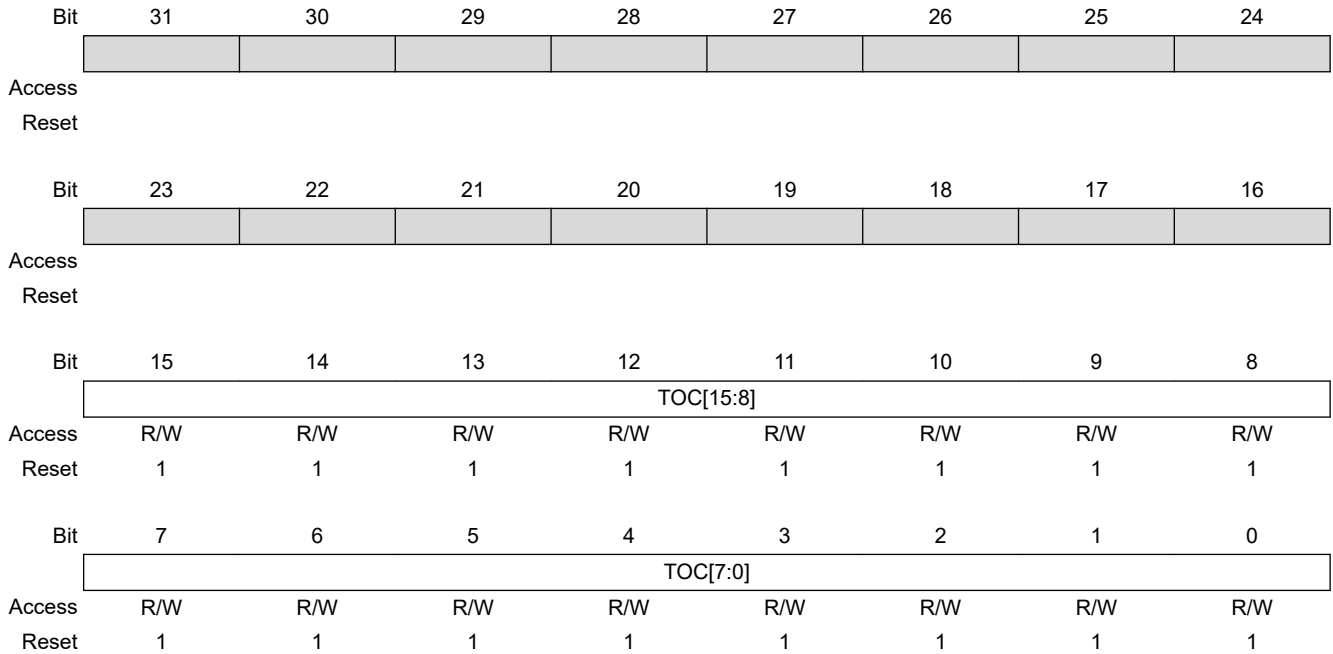
# SAM D5x/E5x Family Data Sheet

## CAN - Control Area Network

### 39.8.12 Timeout Counter Value

**Name:** TOCV  
**Offset:** 0x2C  
**Reset:** 0x0000FFFF  
**Property:** Read-only

**Note:** A write access to TOCV reloads the Timeout Counter with the value of TOCV.TOP.



#### Bits 15:0 – TOC[15:0] Timeout Counter

The Timeout Counter is decremented in multiples of CAN bit times [1...16] depending on the configuration of TSCC.TCP. When decremented to zero, interrupt flag IR.TOO is set and the Timeout Counter is stopped. Start and reset/restart conditions are configured via TOCC.TOS.



# SAM D5x/E5x Family Data Sheet

## CAN - Control Area Network

### 39.8.13 Error Counter

**Name:** ECR  
**Offset:** 0x40  
**Reset:** 0x00000000  
**Property:** Read-only

**Note:** When CCCR.ASM is set, the CAN protocol controller does not increment TEC and REC when a CAN protocol error is detected, but CEL is still incremented.

Bit	31	30	29	28	27	26	25	24
Access								
Reset								
Bit	23	22	21	20	19	18	17	16
	CEL[7:0]							
Access	R	R	R	R	R	R	R	R
Reset	0	0	0	0	0	0	0	0
Bit	15	14	13	12	11	10	9	8
	RP	REC[6:0]						
Access	R	R	R	R	R	R	R	R
Reset	0	0	0	0	0	0	0	0
Bit	7	6	5	4	3	2	1	0
	TEC[7:0]							
Access	R	R	R	R	R	R	R	R
Reset	0	0	0	0	0	0	0	0

**Bits 23:16 – CEL[7:0]** CAN Error Logging

The counter is incremented each time when a CAN protocol error causes the Transmit Error Counter or Receive Error Counter to be incremented. It is reset by read access to CEL. The counter stops at 0xFF; the next increment of TEC or REC sets interrupt flag IR.ELO.

**Bit 15 – RP** Receive Error Passive

**Bits 14:8 – REC[6:0]** Receive Error Counter

Actual state of the Receive Error Counter, values between 0 and 127.

**Bits 7:0 – TEC[7:0]** Transmit Error Counter

Actual state of the Transmit Error Counter, values between 0 and 255.

# SAM D5x/E5x Family Data Sheet

## CAN - Control Area Network

### 39.8.14 Protocol Status

**Name:** PSR  
**Offset:** 0x44  
**Reset:** 0x00000707  
**Property:** Read-only

**Note:**

- When a frame in CAN FD format has reached the data phase with BRS flag set, the next CAN event (error or valid frame) will be shown in FLEC instead of LEC. An error in a fixed stuff bit of a CAN FD CRC sequence will be shown as a Form Error, not Stuff Error.
- The Bus\_Off recovery sequence (see CAN Specification Rev. 2.0 or ISO 11898-1) cannot be shortened by setting or resetting CCCR.INIT. If the device goes Bus\_Off, it will set CCCR.INIT of its own accord, stopping all bus activities. Once CCCR.INIT has been cleared by the CPU, the device will then wait for 129 occurrences of Bus Idle (129 \* 11 consecutive recessive bits) before resuming normal operation. At the end of the Bus\_Off recovery sequence, the Error Management Counters will be reset. During the waiting time after the resetting of CCCR.INIT, each time a sequence of 11 recessive bits has been monitored, a Bit0 Error code is written to PSR.LEC, enabling the CPU to readily check up whether the CAN bus is stuck at dominant or continuously disturbed and to monitor the Bus\_Off recovery sequence. ECR.REC is used to count these sequences.

Bit	31	30	29	28	27	26	25	24
Access								
Reset								
Bit	23	22	21	20	19	18	17	16
Access	R							
Reset	0							
Bit	15	14	13	12	11	10	9	8
			PXE	RFDF	RBRS	RESI		
Access			R	R	R	R	R	R
Reset			0	0	0	0	1	1
Bit	7	6	5	4	3	2	1	0
Access	R		R	R	R	R	R	R
Reset	0		0	0	0	1	1	1

**Bits 22:16 – TDCV[6:0] Transmitter Delay Compensation Value**

Value	Description
0x00 – 0x7F	Position of the secondary sample point, defined by the sum of the measured delay from CAN_TX to CAN_RX and TDCR.TDCO. The SSP position is, in the data phase, the number of mtq between the start of the transmitted bit and the secondary sample point. Valid values are 0 to 127 mtq.

**Bit 14 – PXE** Protocol Exception Event

This field is cleared on read access.

Value	Description
0	No protocol exception event occurred since last read access.
1	Protocol exception event occurred.

**Bit 13 – RFDF** Received a CAN FD Message

This field is cleared on read access.

Value	Description
0	Since this bit was reset by the CPU, no CAN FD message has been received.
1	Message in CAN FD format with FDF flag set has been received. This bit is set independent of acceptance filtering.

**Bit 12 – RBRS** BRS flag of last received CAN FD Message

This field is cleared on read access.

Value	Description
0	Last received CAN FD message did not have its BRS flag set.
1	Last received CAN FD message had its BRS flag set. This bit is set together with RFDF, independent of acceptance filtering.

**Bit 11 – RESI** ESI flag of last received CAN FD Message

This field is cleared on read access.

Value	Description
0	Last received CAN FD message did not have its ESI flag set.
1	Last received CAN FD message had its ESI flag set.

**Bits 10:8 – DLEC[2:0]** Data Last Error Code

Type of last error that occurred in the data phase of a CAN FD format frame with its BRS flag set. Coding is the same as for LEC. This field will be cleared to zero when a CAN FD format frame with its BRS flag set has been transferred (reception or transmission) without error.

**Bit 7 – BO** Bus\_Off Status

Value	Description
0	The CAN is not Bus_Off.
1	The CAN is in Bus_Off state.

**Bit 6 – EW** Error Warning Status

Value	Description
0	Both error counters are below the Error_Warning limit of 96.
1	At least one of the error counter has reached the Error_Warning limit of 96.

**Bit 5 – EP** Error Passive

Value	Description
0	The CAN is in the Error_Active state. It normally takes part in bus communication and sends an active error flag when an error has been detected.
1	The CAN is in the Error_Passive state.

**Bits 4:3 – ACT[1:0]** Activity

Monitors the module's CAN communication state.

# SAM D5x/E5x Family Data Sheet

## CAN - Control Area Network

Value	Name	Description
0x0	SYNC	Node is synchronizing on CAN communication.
0x1	IDLE	Node is neither receiver nor transmitter.
0x2	RX	Node is operating as receiver.
0x3	TX	Node is operating as transmitter.

### Bits 2:0 – LEC[2:0] Last Error Code

The LEC indicates the type of the last error to occur on the CAN bus. This field will be cleared to '0' when a message has been transferred (reception or transmission) without error.

This field is set on read access.

Value	Name	Description
0x0	NONE	No Error: No error occurred since LEC has been reset by successful reception or transmission.
0x1	STUFF	Stuff Error: More than 5 equal bits in a sequence have occurred in a part of a received message where this is not allowed.
0x2	FORM	Form Error: A fixed format part of a received frame has the wrong format.
0x3	ACK	Ack Error: The message transmitted by the CAN was not acknowledged by another node.
0x4	BIT1	Bit1 Error: During the transmission of a message (with the exception of the arbitration field), the device wanted to send a recessive level (bit of logical value '1'), but the monitored bus was dominant.
0x5	BIT0	Bit0 Error: During the transmission of a message (or acknowledge bit, or active error flag, or overload flag), the device wanted to send a dominant level (data or identifier bit logical value '0'), but the monitored bus value was recessive. During Bus_Off recovery this status is set each time a sequence of 11 recessive bits have been monitored. This enables the CPU to monitor the proceeding of the Bus_Off recovery sequence (indicating the bus is not stuck at dominant or continuously disturbed).
0x6	CRC	CRC Error: The CRC checksum of a received message was incorrect. The CRC of an incoming message does not match with the CRC calculated from the received data.
0x7	NC	No Change: Any read access to the Protocol Status Register re-initializes the LEC to '7'. When the LEC shows the value '7', no CAN bus event was detected since the last CPU read access to the Protocol Status Register.

# SAM D5x/E5x Family Data Sheet

## CAN - Control Area Network

### 39.8.15 Transmitter Delay Compensation

**Name:** TDCR  
**Offset:** 0x48  
**Reset:** 0x00000000  
**Property:** Write-restricted

This register is write-restricted and only writable if bit fields CCCR.CCE = 1 and CCCR.INIT = 1.

Bit	31	30	29	28	27	26	25	24
Access								
Reset								
Bit	23	22	21	20	19	18	17	16
Access								
Reset								
Bit	15	14	13	12	11	10	9	8
		TDCO[6:0]						
Access		R/W	R/W	R/W	R/W	R/W	R/W	R/W
Reset		0	0	0	0	0	0	0
Bit	7	6	5	4	3	2	1	0
		TDCF[6:0]						
Access		R/W	R/W	R/W	R/W	R/W	R/W	R/W
Reset		0	0	0	0	0	0	0

#### Bits 14:8 – TDCO[6:0] Transmitter Delay Compensation Offset

Value	Description
0x00 – 0x7F	Offset value defining the distance between the measured delay from CAN_TX to CAN_RX and the secondary sample point. Valid values are 0 to 127 mtq.

#### Bits 6:0 – TDCF[6:0] Transmitter Delay Compensation Filter Window Length

Value	Description
0x00 – 0x7F	Defines the minimum value for the SSP position, dominant edges on CAN_RX that would result in an earlier SSP position are ignored for transmitter delay measurement. The feature is enabled when TDCF is configured to a value greater than TDCO. Valid values are 0 to 127 mtq.

# SAM D5x/E5x Family Data Sheet

## CAN - Control Area Network

### 39.8.16 Interrupt

**Name:** IR  
**Offset:** 0x50  
**Reset:** 0x00000000  
**Property:** -

The flags are set when one of the listed conditions is detected (edge-sensitive). A flag is cleared by writing a 1 to the corresponding bit field. Writing a 0 has no effect. A hard reset will clear the register.

Bit	31	30	29	28	27	26	25	24
			ARA	PED	PEA	WDI	BO	EW
Access			R/W	R/W	R/W	R/W	R/W	R/W
Reset			0	0	0	0	0	0
Bit	23	22	21	20	19	18	17	16
	EP	ELO	BEU	BEC	DRX	TOO	MRAF	TSW
Access	R/W	R/W	R/W	R/W	R/W	R/W	R/W	R/W
Reset	0	0	0	0	0	0	0	0
Bit	15	14	13	12	11	10	9	8
	TEFL	TEFF	TEFW	TEFN	TFE	TCF	TC	HPM
Access	R/W	R/W	R/W	R/W	R/W	R/W	R/W	R/W
Reset	0	0	0	0	0	0	0	0
Bit	7	6	5	4	3	2	1	0
	RF1L	RF1F	RF1W	RF1N	RF0L	RF0F	RF0W	RF0N
Access	R/W	R/W	R/W	R/W	R/W	R/W	R/W	R/W
Reset	0	0	0	0	0	0	0	0

#### Bit 29 – ARA Access to Reserved Address

Value	Description
0	No access to reserved address occurred.
1	Access to reserved address occurred.

#### Bit 28 – PED Protocol Error in Data Phase

Value	Description
0	No protocol error in data phase.
1	Protocol error in data phase detected (PSR.DLEC != 0,7).

#### Bit 27 – PEA Protocol Error in Arbitration Phase

Value	Description
0	No protocol error in arbitration phase.
1	Protocol error in arbitration phase detected (PSR.LEC != 0,7).

#### Bit 26 – WDI Watchdog Interrupt

Value	Description
0	No Message RAM Watchdog event occurred.
1	Message RAM Watchdog event due to missing READY.

**Bit 25 – BO** Bus\_Off Status

Value	Description
0	Bus_Off status unchanged.
1	Bus_Off status changed.

**Bit 24 – EW** Error Warning Status

Value	Description
0	Error_Warning status unchanged.
1	Error_Warning status changed.

**Bit 23 – EP** Error Passive

Value	Description
0	Error_Passive status unchanged.
1	Error_Passive status changed.

**Bit 22 – ELO** Error Logging Overflow

Value	Description
0	CAN Error Logging Counter did not overflow.
1	Overflow of CAN Error Logging Counter occurred.

**Bit 21 – BEU** Bit Error Uncorrected

Message RAM bit error detected, uncorrected. Generated by an optional external parity / ECC logic attached to the Message RAM. An uncorrected Message RAM bit sets CCCR.INIT to 1. This is done to avoid transmission of corrupted data.

Value	Description
0	Not bit error detected when reading from Message RAM.
1	Bit error detected, uncorrected (e.g. parity logic).

**Bit 20 – BEC** Bit Error Corrected

Message RAM bit error detected and corrected. Generated by an optional external parity / ECC logic attached to the Message RAM.

Value	Description
0	Not bit error detected when reading from Message RAM.
1	Bit error detected and corrected (e.g. ECC).

**Bit 19 – DRX** Message stored to Dedicated Rx Buffer

The flag is set whenever a received message has been stored into a dedicated Rx Buffer.

Value	Description
0	No Rx Buffer updated.
1	At least one received message stored into a Rx Buffer.

**Bit 18 – TOO** Timeout Occurred

Value	Description
0	No timeout.
1	Timeout reached.

**Bit 17 – MRAF** Message RAM Access Failure

The flag is set, when the Rx Handler

# SAM D5x/E5x Family Data Sheet

## CAN - Control Area Network

- has not completed acceptance filtering or storage of an accepted message until the arbitration field of the following message has been received. In this case acceptance filtering or message storage is aborted and the Rx Handler starts processing of the following message.
- was not able to write a message to the Message RAM. In this case message storage is aborted.

In both cases the FIFO put index is not updated resp. the New Data flag for a dedicated Rx Buffer is not set, a partly stored message is overwritten when the next message is stored to this location.

The flag is also set when the Tx Handler was not able to read a message from the Message RAM in time. In this case message transmission is aborted. In case of a Tx Handler access failure the CAN is switched into Restricted Operation Mode. To leave Restricted Operation Mode, the Host CPU has to reset CCCR.ASM.

Value	Description
0	No Message RAM access failure occurred.
1	Message RAM access failure occurred.

### Bit 16 – TSW Timestamp Wraparound

Value	Description
0	No timestamp counter wrap-around.
1	Timestamp counter wrapped around.

### Bit 15 – TEFL Tx Event FIFO Element Lost

Value	Description
0	No Tx Event FIFO element lost.
1	Tx Event FIFO element lost, also set after write attempt to Tx Event FIFO of size zero.

### Bit 14 – TEFF Tx Event FIFO Full

Value	Description
0	Tx Event FIFO not full.
1	Tx Event FIFO full.

### Bit 13 – TEFW Tx Event FIFO Watermark Reached

Value	Description
0	Tx Event FIFO fill level below watermark.
1	Tx Event FIFO fill level reached watermark.

### Bit 12 – TEFN Tx Event FIFO New Entry

Value	Description
0	Tx Event FIFO unchanged.
1	Tx Handler wrote Tx Event FIFO element.

### Bit 11 – TFE Tx FIFO Empty

Value	Description
0	Tx FIFO non-empty.
1	Tx FIFO empty.

### Bit 10 – TCF Transmission Cancellation Finished

Value	Description
0	No transmission cancellation finished.
1	Transmission cancellation finished.



# SAM D5x/E5x Family Data Sheet

## CAN - Control Area Network

### Bit 9 – TC Timestamp Completed

Value	Description
0	No transmission completed.
1	Transmission completed.

### Bit 8 – HPM High Priority Message

Value	Description
0	No high priority message received.
1	High priority message received.

### Bit 7 – RF1L Rx FIFO 1 Message Lost

Value	Description
0	No Rx FIFO 1 message lost.
1	Rx FIFO 1 message lost. also set after write attempt to Rx FIFO 1 of size zero.

### Bit 6 – RF1F Rx FIFO 1 Full

Value	Description
0	Rx FIFO 1 not full.
1	Rx FIFO 1 full.

### Bit 5 – RF1W Rx FIFO 1 Watermark Reached

Value	Description
0	Rx FIFO 1 fill level below watermark.
1	Rx FIFO 1 fill level reached watermark.

### Bit 4 – RF1N Rx FIFO 1 New Message

Value	Description
0	No new message written to Rx FIFO 1.
1	New message written to Rx FIFO 1.

### Bit 3 – RF0L Rx FIFO 0 Message Lost

Value	Description
0	No Rx FIFO 0 message lost.
1	Rx FIFO 0 message lost. also set after write attempt to Rx FIFO 0 of size zero.

### Bit 2 – RF0F Rx FIFO 0 Full

Value	Description
0	Rx FIFO 0 not full.
1	Rx FIFO 0 full.

### Bit 1 – RF0W Rx FIFO 0 Watermark Reached

Value	Description
0	Rx FIFO 0 fill level below watermark.
1	Rx FIFO 0 fill level reached watermark.

### Bit 0 – RF0N Rx FIFO 0 New Message

Value	Description
0	No new message written to Rx FIFO 0.
1	New message written to Rx FIFO 0.

# SAM D5x/E5x Family Data Sheet

## CAN - Control Area Network

### 39.8.17 Interrupt Enable

**Name:** IE  
**Offset:** 0x54  
**Reset:** 0x00000000  
**Property:** -

The settings in the Interrupt Enable register determine which status changes in the Interrupt Register will be signalled on an interrupt line.

Bit	31	30	29	28	27	26	25	24
			ARAE	PEDE	PEAE	WDIE	BOE	EWE
Access			R/W	R/W	R/W	R/W	R/W	R/W
Reset			0	0	0	0	0	0
Bit	23	22	21	20	19	18	17	16
	EPE	ELOE	BEUE	BECE	DRXE	TOOE	MRAFE	TSWE
Access	R/W	R/W	R/W	R/W	R/W	R/W	R/W	R/W
Reset	0	0	0	0	0	0	0	0
Bit	15	14	13	12	11	10	9	8
	TEFLE	TEFFE	TEFWE	TEFNE	TFEE	TCFE	TCE	HPME
Access	R/W	R/W	R/W	R/W	R/W	R/W	R/W	R/W
Reset	0	0	0	0	0	0	0	0
Bit	7	6	5	4	3	2	1	0
	RF1LE	RF1FE	RF1WE	RF1NE	RF0LE	RF0FE	RF0WE	RF0NE
Access	R/W	R/W	R/W	R/W	R/W	R/W	R/W	R/W
Reset	0	0	0	0	0	0	0	0

#### Bit 29 – ARAE Access to Reserved Address Interrupt Enable

Value	Description
0	Interrupt disabled.
1	Interrupt enabled.

#### Bit 28 – PEDE Protocol Error in Data Phase Interrupt Enable

Value	Description
0	Interrupt disabled.
1	Interrupt enabled.

#### Bit 27 – PEAE Protocol Error in Arbitration Phase Interrupt Enable

Value	Description
0	Interrupt disabled.
1	Interrupt enabled.

#### Bit 26 – WDIE Watchdog Interrupt Enable

Value	Description
0	Interrupt disabled.
1	Interrupt enabled.

**Bit 25 – BOE** Bus\_Off Status Interrupt Enable

Value	Description
0	Interrupt disabled.
1	Interrupt enabled.

**Bit 24 – EWE** Error Warning Status Interrupt Enable

Value	Description
0	Interrupt disabled.
1	Interrupt enabled.

**Bit 23 – EPE** Error Passive Interrupt Enable

Value	Description
0	Interrupt disabled.
1	Interrupt enabled.

**Bit 22 – ELOE** Error Logging Overflow Interrupt Enable

Value	Description
0	Interrupt disabled.
1	Interrupt enabled.

**Bit 21 – BEUE** Bit Error Uncorrected Interrupt Enable.

Value	Description
0	Interrupt disabled.
1	Interrupt enabled.

**Bit 20 – BECE** Bit Error Corrected Interrupt Enable

Value	Description
0	Interrupt disabled.
1	Interrupt enabled.

**Bit 19 – DRXE** Message stored to Dedicated Rx Buffer Interrupt Enable

Value	Description
0	Interrupt disabled.
1	Interrupt enabled.

**Bit 18 – TOOE** Timeout Occurred Interrupt Enable

Value	Description
0	Interrupt disabled.
1	Interrupt enabled.

**Bit 17 – MRAFE** Message RAM Access Failure Interrupt Enable

Value	Description
0	Interrupt disabled.
1	Interrupt enabled.

**Bit 16 – TSWE** Timestamp Wraparound Interrupt Enable

Value	Description
0	Interrupt disabled.
1	Interrupt enabled.

# SAM D5x/E5x Family Data Sheet

## CAN - Control Area Network

### Bit 15 – TEFLE Tx Event FIFO Event Lost Interrupt Enable

Value	Description
0	Interrupt disabled.
1	Interrupt enabled.

### Bit 14 – TEF FE Tx Event FIFO Full Interrupt Enable

Value	Description
0	Interrupt disabled.
1	Interrupt enabled.

### Bit 13 – TEFWE Tx Event FIFO Watermark Reached Interrupt Enable

Value	Description
0	Interrupt disabled.
1	Interrupt enabled.

### Bit 12 – TEFNE Tx Event FIFO New Entry Interrupt Enable

Value	Description
0	Interrupt disabled.
1	Interrupt enabled.

### Bit 11 – TFEE Tx FIFO Empty Interrupt Enable

Value	Description
0	Interrupt disabled.
1	Interrupt enabled.

### Bit 10 – TCFE Transmission Cancellation Finished Interrupt Enable

Value	Description
0	Interrupt disabled.
1	Interrupt enabled.

### Bit 9 – TCE Transmission Completed Interrupt Enable

Value	Description
0	Interrupt disabled.
1	Interrupt enabled.

### Bit 8 – HPME High Priority Message Interrupt Enable

Value	Description
0	Interrupt disabled.
1	Interrupt enabled.

### Bit 7 – RF1LE Rx FIFO 1 Message Lost Interrupt Enable

Value	Description
0	Interrupt disabled.
1	Interrupt enabled.

### Bit 6 – RF1FE Rx FIFO 1 Full Interrupt Enable

Value	Description
0	Interrupt disabled.
1	Interrupt enabled.

# SAM D5x/E5x Family Data Sheet

## CAN - Control Area Network

---

---

**Bit 5 – RF1WE** Rx FIFO 1 Watermark Reached Interrupt Enable

Value	Description
0	Interrupt disabled.
1	Interrupt enabled.

**Bit 4 – RF1NE** Rx FIFO 1 New Message Interrupt Enable

Value	Description
0	Interrupt disabled.
1	Interrupt enabled.

**Bit 3 – RF0LE** Rx FIFO 0 Message Lost Interrupt Enable

Value	Description
0	Interrupt disabled.
1	Interrupt enabled.

**Bit 2 – RF0FE** Rx FIFO 0 Full Interrupt Enable

Value	Description
0	Interrupt disabled.
1	Interrupt enabled.

**Bit 1 – RF0WE** Rx FIFO 0 Watermark Reached Interrupt Enable

Value	Description
0	Interrupt disabled.
1	Interrupt enabled.

**Bit 0 – RF0NE** Rx FIFO 0 New Message Interrupt Enable

Value	Description
0	Interrupt disabled.
1	Interrupt enabled.

# SAM D5x/E5x Family Data Sheet

## CAN - Control Area Network

### 39.8.18 Interrupt Line Select

**Name:** ILS  
**Offset:** 0x58  
**Reset:** 0x00000000  
**Property:** -

The Interrupt Line Select register assigns an interrupt generated by a specific interrupt flag from IR to one of the two module interrupt lines.

Bit	31	30	29	28	27	26	25	24
			ARAL	PEDL	PEAL	WDIL	BOL	EWL
Access			R/W	R/W	R/W	R/W	R/W	R/W
Reset			0	0	0	0	0	0
Bit	23	22	21	20	19	18	17	16
	EPL	ELOL	BEUL	BECL	DRXL	TOOL	MRAFL	TSWL
Access	R/W	R/W	R/W	R/W	R/W	R/W	R/W	R/W
Reset	0	0	0	0	0	0	0	0
Bit	15	14	13	12	11	10	9	8
	TEFLL	TEFFL	TEFWL	TEFNL	TFEL	TCFL	TCL	HPML
Access	R/W	R/W	R/W	R/W	R/W	R/W	R/W	R/W
Reset	0	0	0	0	0	0	0	0
Bit	7	6	5	4	3	2	1	0
	RF1LL	RF1FL	RF1WL	RF1NL	RF0LL	RF0FL	RF0WL	RF0NL
Access	R/W	R/W	R/W	R/W	R/W	R/W	R/W	R/W
Reset	0	0	0	0	0	0	0	0

#### Bit 29 – ARAL Access to Reserved Address Interrupt Line

Value	Description
0	Interrupt assigned to CAN interrupt line 0.
1	Interrupt assigned to CAN interrupt line 1.

#### Bit 28 – PEDL Protocol Error in Data Phase Interrupt Line

Value	Description
0	Interrupt assigned to CAN interrupt line 0.
1	Interrupt assigned to CAN interrupt line 1.

#### Bit 27 – PEAL Protocol Error in Arbitration Phase Interrupt Line

Value	Description
0	Interrupt assigned to CAN interrupt line 0.
1	Interrupt assigned to CAN interrupt line 1.

#### Bit 26 – WDIL Watchdog Interrupt Line

Value	Description
0	Interrupt assigned to CAN interrupt line 0.
1	Interrupt assigned to CAN interrupt line 1.

**Bit 25 – BOL** Bus\_Off Status Interrupt Line

Value	Description
0	Interrupt assigned to CAN interrupt line 0.
1	Interrupt assigned to CAN interrupt line 1.

**Bit 24 – EWL** Error Warning Status Interrupt Line

Value	Description
0	Interrupt assigned to CAN interrupt line 0.
1	Interrupt assigned to CAN interrupt line 1.

**Bit 23 – EPL** Error Passive Interrupt Line

Value	Description
0	Interrupt assigned to CAN interrupt line 0.
1	Interrupt assigned to CAN interrupt line 1.

**Bit 22 – ELOL** Error Logging Overflow Interrupt Line

Value	Description
0	Interrupt assigned to CAN interrupt line 0.
1	Interrupt assigned to CAN interrupt line 1.

**Bit 21 – BEUL** Bit Error Uncorrected Interrupt Line

Value	Description
0	Interrupt assigned to CAN interrupt line 0.
1	Interrupt assigned to CAN interrupt line 1.

**Bit 20 – BECL** Bit Error Corrected Interrupt Line

Value	Description
0	Interrupt assigned to CAN interrupt line 0.
1	Interrupt assigned to CAN interrupt line 1.

**Bit 19 – DRXL** Message stored to Dedicated Rx Buffer Interrupt Line

Value	Description
0	Interrupt assigned to CAN interrupt line 0.
1	Interrupt assigned to CAN interrupt line 1.

**Bit 18 – TOOL** Timeout Occurred Interrupt Line

Value	Description
0	Interrupt assigned to CAN interrupt line 0.
1	Interrupt assigned to CAN interrupt line 1.

**Bit 17 – MRAFL** Message RAM Access Failure Interrupt Line

Value	Description
0	Interrupt assigned to CAN interrupt line 0.
1	Interrupt assigned to CAN interrupt line 1.

**Bit 16 – TSWL** Timestamp Wraparound Interrupt Line

Value	Description
0	Interrupt assigned to CAN interrupt line 0.
1	Interrupt assigned to CAN interrupt line 1.

# SAM D5x/E5x Family Data Sheet

## CAN - Control Area Network

### Bit 15 – TEFL Tx Event FIFO Event Lost Interrupt Line

Value	Description
0	Interrupt assigned to CAN interrupt line 0.
1	Interrupt assigned to CAN interrupt line 1.

### Bit 14 – TEFFL Tx Event FIFO Full Interrupt Line

Value	Description
0	Interrupt assigned to CAN interrupt line 0.
1	Interrupt assigned to CAN interrupt line 1.

### Bit 13 – TEFWL Tx Event FIFO Watermark Reached Interrupt Line

Value	Description
0	Interrupt assigned to CAN interrupt line 0.
1	Interrupt assigned to CAN interrupt line 1.

### Bit 12 – TEFNL Tx Event FIFO New Entry Interrupt Line

Value	Description
0	Interrupt assigned to CAN interrupt line 0.
1	Interrupt assigned to CAN interrupt line 1.

### Bit 11 – TFEL Tx FIFO Empty Interrupt Line

Value	Description
0	Interrupt assigned to CAN interrupt line 0.
1	Interrupt assigned to CAN interrupt line 1.

### Bit 10 – TCFL Transmission Cancellation Finished Interrupt Line

Value	Description
0	Interrupt assigned to CAN interrupt line 0.
1	Interrupt assigned to CAN interrupt line 1.

### Bit 9 – TCL Transmission Completed Interrupt Line

Value	Description
0	Interrupt assigned to CAN interrupt line 0.
1	Interrupt assigned to CAN interrupt line 1.

### Bit 8 – HPML High Priority Message Interrupt Line

Value	Description
0	Interrupt assigned to CAN interrupt line 0.
1	Interrupt assigned to CAN interrupt line 1.

### Bit 7 – RF1LL Rx FIFO 1 Message Lost Interrupt Line

Value	Description
0	Interrupt assigned to CAN interrupt line 0.
1	Interrupt assigned to CAN interrupt line 1.

### Bit 6 – RF1FL Rx FIFO 1 Full Interrupt Line

Value	Description
0	Interrupt assigned to CAN interrupt line 0.
1	Interrupt assigned to CAN interrupt line 1.



# SAM D5x/E5x Family Data Sheet

## CAN - Control Area Network

---

---

**Bit 5 – RF1WL** Rx FIFO 1 Watermark Reached Interrupt Line

Value	Description
0	Interrupt assigned to CAN interrupt line 0.
1	Interrupt assigned to CAN interrupt line 1.

**Bit 4 – RF1NL** Rx FIFO 1 New Message Interrupt Line

Value	Description
0	Interrupt assigned to CAN interrupt line 0.
1	Interrupt assigned to CAN interrupt line 1.

**Bit 3 – RF0LL** Rx FIFO 0 Message Lost Interrupt Line

Value	Description
0	Interrupt assigned to CAN interrupt line 0.
1	Interrupt assigned to CAN interrupt line 1.

**Bit 2 – RF0FL** Rx FIFO 0 Full Interrupt Line

Value	Description
0	Interrupt assigned to CAN interrupt line 0.
1	Interrupt assigned to CAN interrupt line 1.

**Bit 1 – RF0WL** Rx FIFO 0 Watermark Reached Interrupt Line

Value	Description
0	Interrupt assigned to CAN interrupt line 0.
1	Interrupt assigned to CAN interrupt line 1.

**Bit 0 – RF0NL** Rx FIFO 0 New Message Interrupt Line

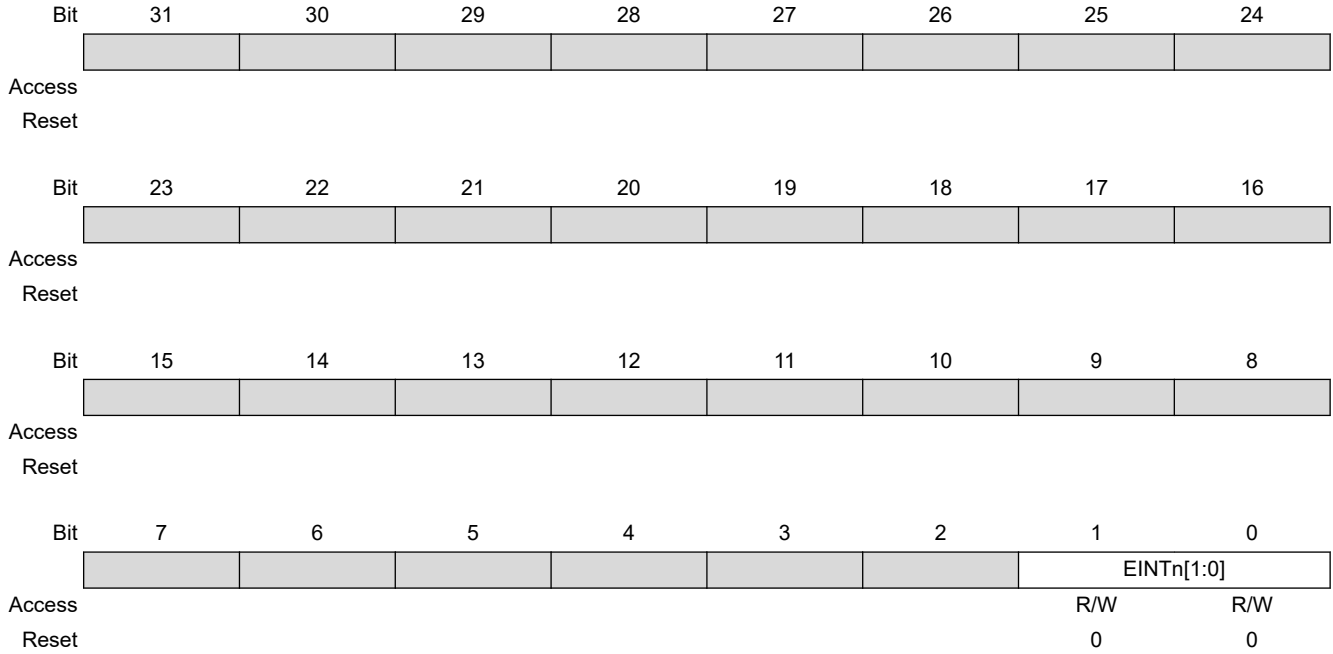
Value	Description
0	Interrupt assigned to CAN interrupt line 0.
1	Interrupt assigned to CAN interrupt line 1.

# SAM D5x/E5x Family Data Sheet

## CAN - Control Area Network

### 39.8.19 Interrupt Line Enable

**Name:** ILE  
**Offset:** 0x5C  
**Reset:** 0x00000000  
**Property:** -



**Bits 1:0 – EINTn[1:0]** Enable Interrupt Line n [n = 1,0]

Value	Description
0	CAN interrupt line n disabled.
1	CAN interrupt line n enabled.

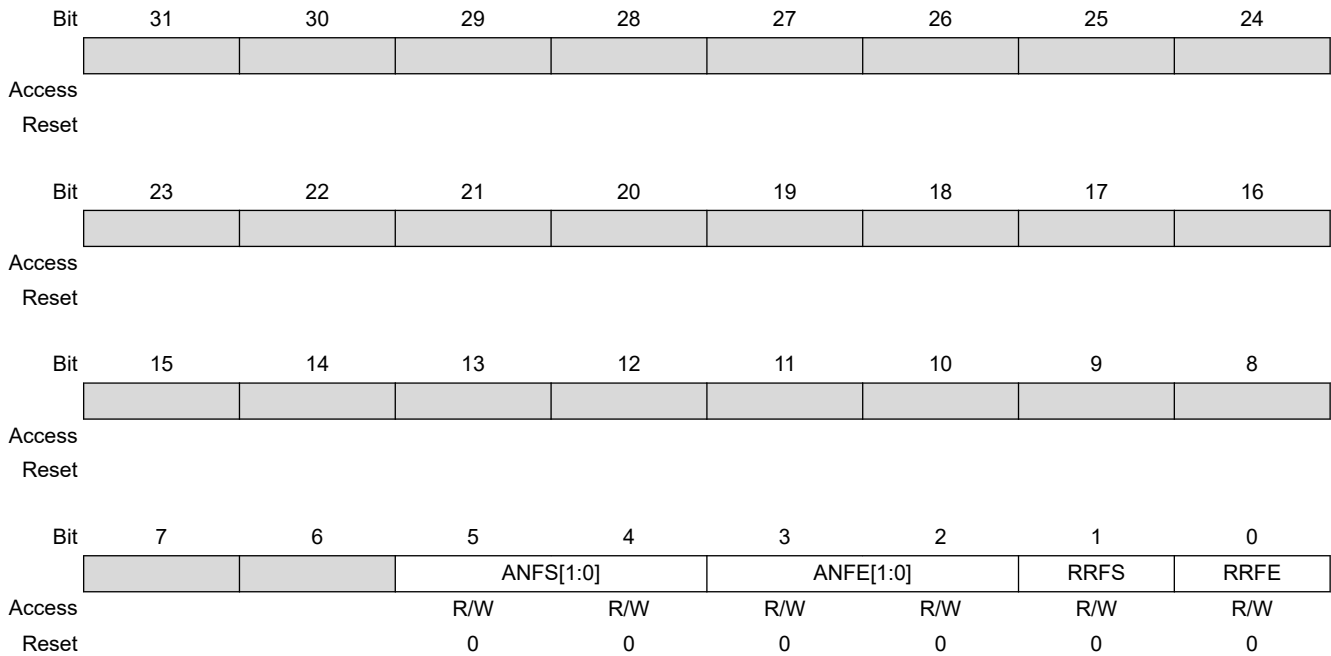
# SAM D5x/E5x Family Data Sheet

## CAN - Control Area Network

### 39.8.20 Global Filter Configuration

**Name:** GFC  
**Offset:** 0x80  
**Reset:** 0x00000000  
**Property:** Write-restricted

This register is write-restricted and only writable if bit fields CCCR.CCE = 1 and CCCR.INIT = 1.



#### Bits 5:4 – ANFS[1:0] Accept Non-matching Frames Standard

Defines how received messages with 11-bit IDs that do not match any element of the filter list are treated.

Value	Name	Description
0x0	RXF0	Accept in Rx FIFO 0.
0x1	RXF1	Accept in Rx FIFO 1.
0x2 or 0x3	REJECT	Reject

#### Bits 3:2 – ANFE[1:0] Accept Non-matching Frames Extended

Defines how received messages with 29-bit IDs that do not match any element of the filter list are treated.

Value	Name	Description
0x0	RXF0	Accept in Rx FIFO 0.
0x1	RXF1	Accept in Rx FIFO 1.
0x2 or 0x3	REJECT	Reject

#### Bit 1 – RRFS Reject Remote Frames Standard

Value	Description
0	Filter remote frames with 11-bit standard IDs.
1	Reject all remote frames with 11-bit standard IDs.

# SAM D5x/E5x Family Data Sheet

## CAN - Control Area Network

---

---

**Bit 0 – RRFE** Reject Remote Frames Extended

Value	Description
0	Filter remote frames with 29-bit extended IDs.
1	Reject all remote frames with 29-bit extended IDS.

# SAM D5x/E5x Family Data Sheet

## CAN - Control Area Network

### 39.8.21 Standard ID Filter Configuration

**Name:** SIDFC  
**Offset:** 0x84  
**Reset:** 0x00000000  
**Property:** Write-restricted

This register is write-restricted and only writable if bit fields CCCR.CCE = 1 and CCCR.INIT = 1.

	Bit	31	30	29	28	27	26	25	24
Access									
Reset									
	Bit	23	22	21	20	19	18	17	16
		LSS[7:0]							
Access		R/W	R/W	R/W	R/W	R/W	R/W	R/W	R/W
Reset		0	0	0	0	0	0	0	0
	Bit	15	14	13	12	11	10	9	8
		FLSSA[15:8]							
Access		R/W	R/W	R/W	R/W	R/W	R/W	R/W	R/W
Reset		0	0	0	0	0	0	0	0
	Bit	7	6	5	4	3	2	1	0
		FLSSA[7:0]							
Access		R/W	R/W	R/W	R/W	R/W	R/W	R/W	R/W
Reset		0	0	0	0	0	0	0	0

#### Bits 23:16 – LSS[7:0] List Size Standard

Value	Description
0	No standard Message ID filter.
1 – 128	Number of standard Message ID filter elements.
> 128	Values greater than 128 are interpreted as 128.

#### Bits 15:0 – FLSSA[15:0] Filter List Standard Start Address

Start address of standard Message ID filter list. When the CAN module addresses the Message RAM it addresses 32-bit words, not single bytes. The configurable start addresses are 32-bit word addresses, i.e. only bits 15 to 2 are evaluated, the two least significant bits are ignored. Bits 1 to 0 will always be read back as “00”.

# SAM D5x/E5x Family Data Sheet

## CAN - Control Area Network

### 39.8.22 Extended ID Filter Configuration

**Name:** XIDFC  
**Offset:** 0x88  
**Reset:** 0x00000000  
**Property:** Write-restricted

	Bit	31	30	29	28	27	26	25	24
		[Greyed out register box]							
Access									
Reset									
	Bit	23	22	21	20	19	18	17	16
		LSE[6:0]							
Access		R/W	R/W	R/W	R/W	R/W	R/W	R/W	R/W
Reset		0	0	0	0	0	0	0	0
	Bit	15	14	13	12	11	10	9	8
		FLESA[15:8]							
Access		R/W	R/W	R/W	R/W	R/W	R/W	R/W	R/W
Reset		0	0	0	0	0	0	0	0
	Bit	7	6	5	4	3	2	1	0
		FLESA[7:0]							
Access		R/W	R/W	R/W	R/W	R/W	R/W	R/W	R/W
Reset		0	0	0	0	0	0	0	0

#### Bits 22:16 – LSE[6:0] List Size Extended

Value	Description
0	No extended Message ID filter.
1 – 64	Number of Extended Message ID filter elements.
> 64	Values greater than 64 are interpreted as 64.

#### Bits 15:0 – FLESA[15:0] Filter List Extended Start Address

Start address of extended Message ID filter list. When the CAN module addresses the Message RAM it addresses 32-bit words, not single bytes. The configurable start addresses are 32-bit word addresses, i.e. only bits 15 to 2 are evaluated, the two least significant bits are ignored. Bits 1 to 0 will always be read back as “00”.

# SAM D5x/E5x Family Data Sheet

## CAN - Control Area Network

### 39.8.23 Extended ID AND Mask

**Name:** XIDAM  
**Offset:** 0x90  
**Reset:** 0x1FFFFFFF  
**Property:** Write-restricted

This register is write-restricted and only writable if bit fields CCCR.CCE = 1 and CCCR.INIT = 1.

Bit	31	30	29	28	27	26	25	24
				EIDM[28:24]				
Access				R/W	R/W	R/W	R/W	R/W
Reset				1	1	1	1	1
Bit	23	22	21	20	19	18	17	16
	EIDM[23:16]							
Access	R/W	R/W	R/W	R/W	R/W	R/W	R/W	R/W
Reset	1	1	1	1	1	1	1	1
Bit	15	14	13	12	11	10	9	8
	EIDM[15:8]							
Access	R/W	R/W	R/W	R/W	R/W	R/W	R/W	R/W
Reset	1	1	1	1	1	1	1	1
Bit	7	6	5	4	3	2	1	0
	EIDM[7:0]							
Access	R/W	R/W	R/W	R/W	R/W	R/W	R/W	R/W
Reset	1	1	1	1	1	1	1	1

#### Bits 28:0 – EIDM[28:0] Extended ID Mask

For acceptance filtering of extended frames the Extended ID AND Mask is ANDed with the Message ID of a received frame. Intended for masking of 29-bit IDs in SAE J1939. With the reset value of all bits set to one the mask is not active.

# SAM D5x/E5x Family Data Sheet

## CAN - Control Area Network

### 39.8.24 High Priority Message Status

**Name:** HPMS  
**Offset:** 0x94  
**Reset:** 0x00000000  
**Property:** Read-only

This register is updated every time a Message ID filter element configured to generate a priority event matches. This can be used to monitor the status of incoming high priority messages and to enable fast access to these messages.

Bit	31	30	29	28	27	26	25	24
	[Greyed out register bits]							
Access								
Reset								
Bit	23	22	21	20	19	18	17	16
	[Greyed out register bits]							
Access								
Reset								
Bit	15	14	13	12	11	10	9	8
	FLST	FIDX[6:0]						
Access	R	R	R	R	R	R	R	R
Reset	0	0	0	0	0	0	0	0
Bit	7	6	5	4	3	2	1	0
	MSI[1:0]		BIDX[5:0]					
Access	R	R	R	R	R	R	R	R
Reset	0	0	0	0	0	0	0	0

#### Bit 15 – FLST Filter List

Indicates the filter list of the matching filter element.

Value	Description
0	Standard Filter List.
1	Extended Filter List.

#### Bits 14:8 – FIDX[6:0] Filter Index

Index of matching filter element. Range is 0 to SIDFC.LSS - 1 (standard) or XIDFC.LSE - 1 (extended).

#### Bits 7:6 – MSI[1:0] Message Storage Indicator

This field defines the message storage information to a FIFO.

Value	Name	Description
0x0	NONE	No FIFO selected.
0x1	LOST	FIFO message lost.
0x2	FIFO0	Message stored in FIFO 0.
0x3	FIFO1	Message stored in FIFO 1.

#### Bits 5:0 – BIDX[5:0] Buffer Index

Index of Rx FIFO element to which the message was stored. Only valid when MSI[1] = 1.



# SAM D5x/E5x Family Data Sheet

## CAN - Control Area Network

### 39.8.25 New Data 1

**Name:** NDAT1  
**Offset:** 0x98  
**Reset:** 0x00000000  
**Property:** -

	Bit	31	30	29	28	27	26	25	24
		NDn[31:24]							
Access		R/W	R/W	R/W	R/W	R/W	R/W	R/W	R/W
Reset		0	0	0	0	0	0	0	0
	Bit	23	22	21	20	19	18	17	16
		NDn[23:16]							
Access		R/W	R/W	R/W	R/W	R/W	R/W	R/W	R/W
Reset		0	0	0	0	0	0	0	0
	Bit	15	14	13	12	11	10	9	8
		NDn[15:8]							
Access		R/W	R/W	R/W	R/W	R/W	R/W	R/W	R/W
Reset		0	0	0	0	0	0	0	0
	Bit	7	6	5	4	3	2	1	0
		NDn[7:0]							
Access		R/W	R/W	R/W	R/W	R/W	R/W	R/W	R/W
Reset		0	0	0	0	0	0	0	0

**Bits 31:0 – NDn[31:0] New Data n [n = 0..31]**

The register holds the New Data flags of Rx Buffers 0 to 31. The flags are set when the respective Rx Buffer has been updated from a received frame. The flags remain set until the Host clears them. A flag is cleared by writing 1 to the corresponding bit position. Writing a 0 has no effect. A hard reset will clear the register.

# SAM D5x/E5x Family Data Sheet

## CAN - Control Area Network

### 39.8.26 New Data 2

**Name:** NDAT2  
**Offset:** 0x9C  
**Reset:** 0x00000000  
**Property:** -

	Bit	31	30	29	28	27	26	25	24
		NDn[31:24]							
Access		R/W	R/W	R/W	R/W	R/W	R/W	R/W	R/W
Reset		0	0	0	0	0	0	0	0
	Bit	23	22	21	20	19	18	17	16
		NDn[23:16]							
Access		R/W	R/W	R/W	R/W	R/W	R/W	R/W	R/W
Reset		0	0	0	0	0	0	0	0
	Bit	15	14	13	12	11	10	9	8
		NDn[15:8]							
Access		R/W	R/W	R/W	R/W	R/W	R/W	R/W	R/W
Reset		0	0	0	0	0	0	0	0
	Bit	7	6	5	4	3	2	1	0
		NDn[7:0]							
Access		R/W	R/W	R/W	R/W	R/W	R/W	R/W	R/W
Reset		0	0	0	0	0	0	0	0

**Bits 31:0 – NDn[31:0] New Data [n = 32..64]**

The register holds the New Data flags of Rx Buffers 32 to 63. The flags are set when the respective Rx Buffer has been updated from a received frame. The flags remain set until the Host clears them. A flag is cleared by writing 1 to the corresponding bit position. Writing a 0 has no effect. A hard reset will clear the register.

# SAM D5x/E5x Family Data Sheet

## CAN - Control Area Network

### 39.8.27 Rx FIFO 0 Configuration

**Name:** RXF0C  
**Offset:** 0xA0  
**Reset:** 0x00000000  
**Property:** Write-restricted

	Bit	31	30	29	28	27	26	25	24
		F0OM		F0WM[6:0]					
Access		R/W	R/W	R/W	R/W	R/W	R/W	R/W	R/W
Reset		0	0	0	0	0	0	0	0
	Bit	23	22	21	20	19	18	17	16
		F0S[6:0]							
Access			R/W	R/W	R/W	R/W	R/W	R/W	R/W
Reset			0	0	0	0	0	0	0
	Bit	15	14	13	12	11	10	9	8
		F0SA[15:8]							
Access		R/W	R/W	R/W	R/W	R/W	R/W	R/W	R/W
Reset		0	0	0	0	0	0	0	0
	Bit	7	6	5	4	3	2	1	0
		F0SA[7:0]							
Access		R/W	R/W	R/W	R/W	R/W	R/W	R/W	R/W
Reset		0	0	0	0	0	0	0	0

#### Bit 31 – F0OM FIFO 0 Operation Mode

FIFO 0 can be operated in blocking or in overwrite mode.

Value	Description
0	FIFO 0 blocking mode.
1	FIFO 0 overwrite mode.

#### Bits 30:24 – F0WM[6:0] Rx FIFO 0 Watermark

Value	Description
0	Watermark interrupt disabled.
1 – 64	Level for Rx FIFO 0 watermark interrupt (IR.RF0W).
>64	Watermark interrupt disabled.

#### Bits 22:16 – F0S[6:0] Rx FIFO 0 Size

The Rx FIFO 0 elements are indexed from 0 to F0S - 1.

Value	Description
0	No Rx FIFO 0
1 – 64	Number of Rx FIFO 0 elements.
>64	Values greater than 64 are interpreted as 64.

**Bits 15:0 – F0SA[15:0]** Rx FIFO 0 Start Address

Start address of Rx FIFO 0 in Message RAM. When the CAN module addresses the Message RAM it addresses 32-bit words, not single bytes. The configurable start addresses are 32-bit word addresses, i.e. only bits 15 to 2 are evaluated, the two least significant bits are ignored. Bits 1 to 0 will always be read back as “00”.

# SAM D5x/E5x Family Data Sheet

## CAN - Control Area Network

### 39.8.28 Rx FIFO 0 Status

**Name:** RXF0S  
**Offset:** 0xA4  
**Reset:** 0x00000000  
**Property:** Read-only

Bit	31	30	29	28	27	26	25	24
							RF0L	F0F
Access							R	R
Reset							0	0
Bit	23	22	21	20	19	18	17	16
			F0PI[5:0]					
Access			R	R	R	R	R	R
Reset			0	0	0	0	0	0
Bit	15	14	13	12	11	10	9	8
			F0GI[5:0]					
Access			R	R	R	R	R	R
Reset			0	0	0	0	0	0
Bit	7	6	5	4	3	2	1	0
		F0FL[6:0]						
Access		R	R	R	R	R	R	R
Reset		0	0	0	0	0	0	0

#### Bit 25 – RF0L Rx FIFO 0 Message Lost

This bit is a copy of interrupt flag IR.RF0L. When IR.RF0L is reset, this bit is also reset. Overwriting the oldest message when RXF0C.F0OM = '1' will not set this flag.

Value	Description
0	No Rx FIFO 0 message lost.
1	Rx FIFO 0 message lost, also set after write attempt to Rx FIFO 0 of size zero.

#### Bit 24 – F0F Rx FIFO 0 Full

Value	Description
0	Rx FIFO 0 not full.
1	Rx FIFO 0 full.

#### Bits 21:16 – F0PI[5:0] Rx FIFO 0 Put Index

Rx FIFO 0 write index pointer, range 0 to 63.

#### Bits 13:8 – F0GI[5:0] Rx FIFO 0 Get Index

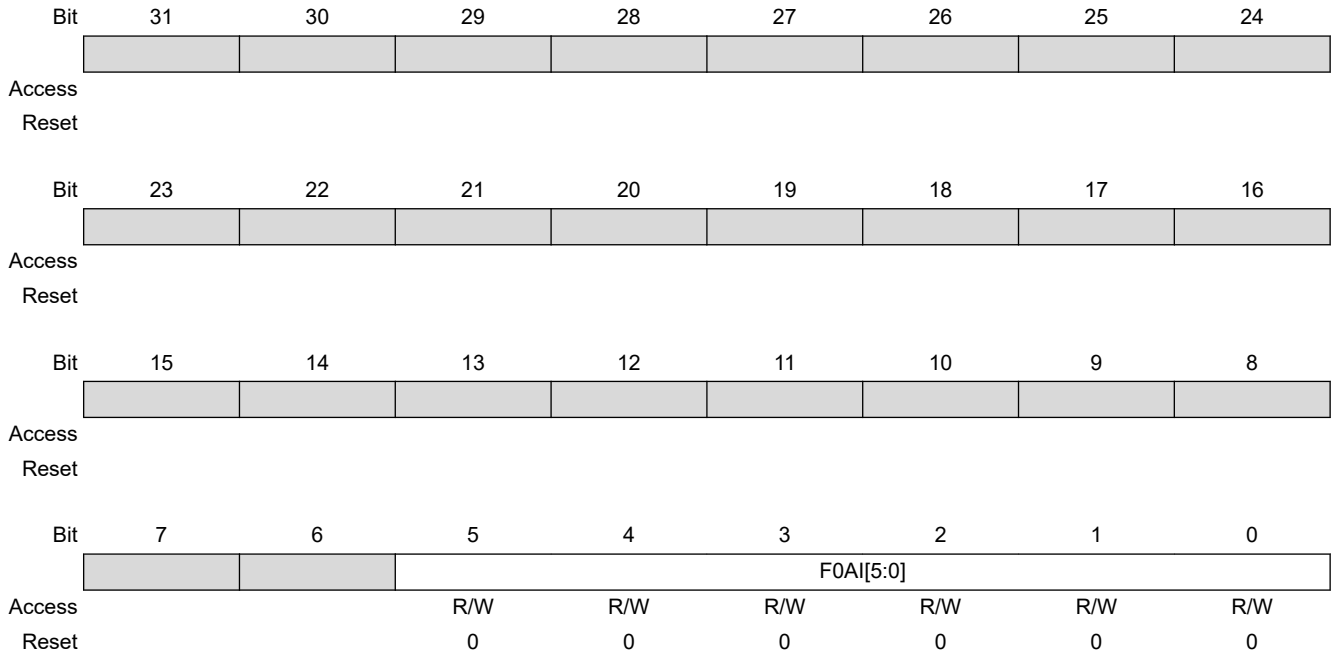
Rx FIFO 0 read index pointer, range 0 to 63.

#### Bits 6:0 – F0FL[6:0] Rx FIFO 0 Fill Level

Number of elements stored in Rx FIFO 0, range 0 to 64.

### 39.8.29 Rx FIFO 0 Acknowledge

**Name:** RXF0A  
**Offset:** 0xA8  
**Reset:** 0x00000000  
**Property:** -



**Bits 5:0 – F0AI[5:0]** Rx FIFO 0 Acknowledge Index

After the Host has read a message or a sequence of messages from Rx FIFO 0 it has to write the buffer index of the last element read from Rx FIFO 0 to F0AI. This will set the Rx FIFO 0 Get Index RXF0S.F0GI to F0AI + 1 and update the FIFO 0 Fill Level RXF0S.F0FL.

# SAM D5x/E5x Family Data Sheet

## CAN - Control Area Network

### 39.8.30 Rx Buffer Configuration

**Name:** RXBC  
**Offset:** 0xAC  
**Reset:** 0x00000000  
**Property:** Write-restricted

This register is write-restricted and only writable if bit fields CCCR.CCE = 1 and CCCR.INIT = 1.

Bit	31	30	29	28	27	26	25	24
Access								
Reset								
Bit	23	22	21	20	19	18	17	16
Access								
Reset								
Bit	15	14	13	12	11	10	9	8
	RBSA[15:8]							
Access	R/W	R/W	R/W	R/W	R/W	R/W	R/W	R/W
Reset	0	0	0	0	0	0	0	0
Bit	7	6	5	4	3	2	1	0
	RBSA[7:0]							
Access	R/W	R/W	R/W	R/W	R/W	R/W	R/W	R/W
Reset	0	0	0	0	0	0	0	0

**Bits 15:0 – RBSA[15:0]** Rx Buffer Start Address

Configures the start address of the Rx Buffers section in the Message RAM. Also used to reference debug message A,B,C. When the CAN module addresses the Message RAM it addresses 32-bit words, not single bytes. The configurable start addresses are 32-bit word addresses, i.e. only bits 15 to 2 are evaluated, the two least significant bits are ignored. Bits 1 to 0 will always be read back as “00”.

# SAM D5x/E5x Family Data Sheet

## CAN - Control Area Network

### 39.8.31 Rx FIFO 1 Configuration

**Name:** RXF1C  
**Offset:** 0xB0  
**Reset:** 0x00000000  
**Property:** Write-restricted

This register is write-restricted and only writable if bit fields CCCR.CCE = 1 and CCCR.INIT = 1.

	Bit	31	30	29	28	27	26	25	24
		F1OM		F1WM[6:0]					
Access		R/W	R/W	R/W	R/W	R/W	R/W	R/W	R/W
Reset		0	0	0	0	0	0	0	0
	Bit	23	22	21	20	19	18	17	16
				F1S[6:0]					
Access			R/W	R/W	R/W	R/W	R/W	R/W	R/W
Reset			0	0	0	0	0	0	0
	Bit	15	14	13	12	11	10	9	8
		F1SA[15:8]							
Access		R/W	R/W	R/W	R/W	R/W	R/W	R/W	R/W
Reset		0	0	0	0	0	0	0	0
	Bit	7	6	5	4	3	2	1	0
		F1SA[7:0]							
Access		R/W	R/W	R/W	R/W	R/W	R/W	R/W	R/W
Reset		0	0	0	0	0	0	0	0

#### Bit 31 – F1OM FIFO 1 Operation Mode

FIFO 1 can be operated in blocking or in overwrite mode.

Value	Description
0	FIFO 1 blocking mode.
1	FIFO 1 overwrite mode.

#### Bits 30:24 – F1WM[6:0] Rx FIFO 1 Watermark

Value	Description
0	Watermark interrupt disabled.
1 – 64	Level for Rx FIFO 1 watermark interrupt (IR.RF1W).
>64	Watermark interrupt disabled.

#### Bits 22:16 – F1S[6:0] Rx FIFO 1 Size

The Rx FIFO 1 elements are indexed from 0 to F1S - 1.

Value	Description
0	No Rx FIFO 1
1 – 64	Number of Rx FIFO 1 elements.
>64	Values greater than 64 are interpreted as 64.



**Bits 15:0 – F1SA[15:0]** Rx FIFO 1 Start Address

Start address of Rx FIFO 1 in Message RAM. When the CAN module addresses the Message RAM it addresses 32-bit words, not single bytes. The configurable start addresses are 32-bit word addresses, i.e. only bits 15 to 2 are evaluated, the two least significant bits are ignored. Bits 1 to 0 will always be read back as “00”.

# SAM D5x/E5x Family Data Sheet

## CAN - Control Area Network

### 39.8.32 Rx FIFO 1 Status

**Name:** RXF1S  
**Offset:** 0xB4  
**Reset:** 0x00000000  
**Property:** Read-only

	Bit	31	30	29	28	27	26	25	24
		DMS[1:0]						RF1L	F1F
Access		R	R					R	R
Reset		0	0					0	0
	Bit	23	22	21	20	19	18	17	16
		F1PI[5:0]							
Access				R	R	R	R	R	R
Reset				0	0	0	0	0	0
	Bit	15	14	13	12	11	10	9	8
		F1GI[5:0]							
Access				R	R	R	R	R	R
Reset				0	0	0	0	0	0
	Bit	7	6	5	4	3	2	1	0
		F1FL[6:0]							
Access			R	R	R	R	R	R	R
Reset			0	0	0	0	0	0	0

#### Bits 31:30 – DMS[1:0] Debug Message Status

This field defines the debug message status.

Value	Name	Description
0x0	IDLE	Idle state, wait for reception of debug messages, DMA request is cleared.
0x1	DBGA	Debug message A received.
0x2	DBGB	Debug message A, B received.
0x3	DBGC	Debug message A, B, C received, DMA request is set.

#### Bit 25 – RF1L Rx FIFO 1 Message Lost

This bit is a copy of interrupt flag IR.RF1L. When IR.RF1L is reset, this bit is also reset.

Overwriting the oldest message when RXF1C.FOOM = '1' will not set this flag.

Value	Description
0	No Rx FIFO 1 message lost.
1	Rx FIFO 1 message lost, also set after write attempt to Rx FIFO 1 of size zero.

#### Bit 24 – F1F Rx FIFO 1 Full

Value	Description
0	Rx FIFO 1 not full.
1	Rx FIFO 1 full.

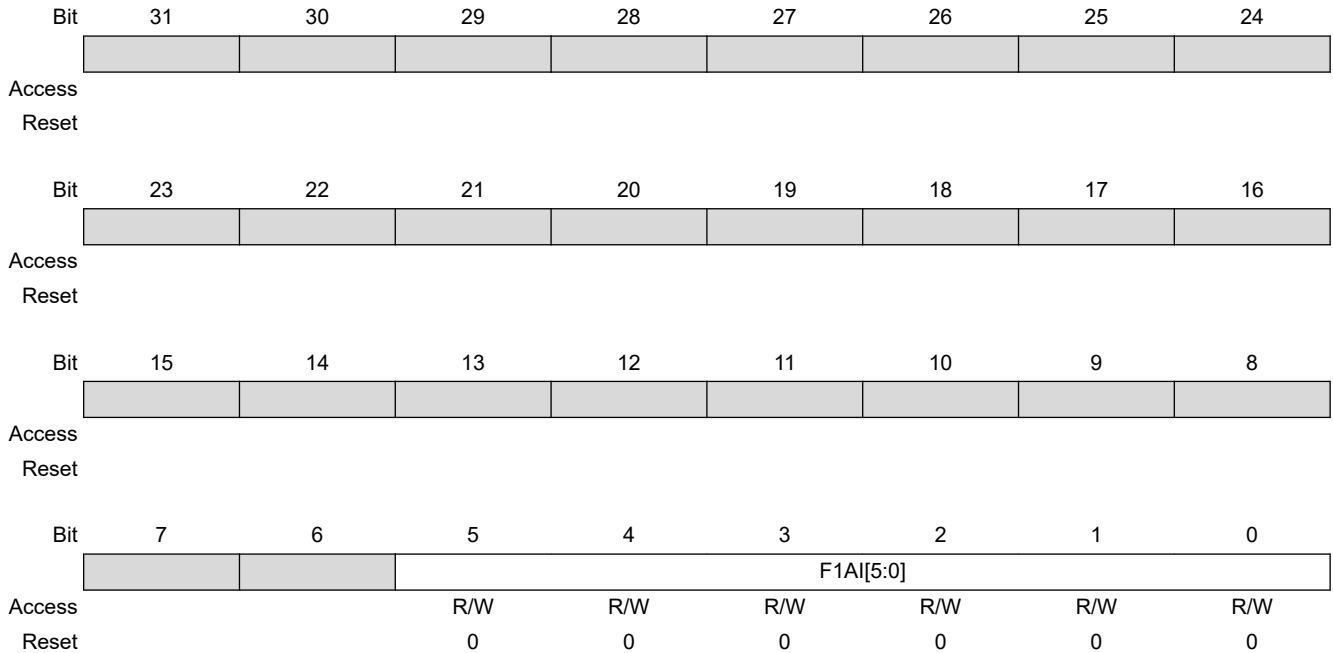
**Bits 21:16 – F1PI[5:0]** Rx FIFO 1 Put Index  
Rx FIFO 1 write index pointer, range 0 to 63.

**Bits 13:8 – F1GI[5:0]** Rx FIFO 1 Get Index  
Rx FIFO 1 read index pointer, range 0 to 63.

**Bits 6:0 – F1FL[6:0]** Rx FIFO 1 Fill Level  
Number of elements stored in Rx FIFO 1, range 0 to 64.

### 39.8.33 Rx FIFO 1 Acknowledge

**Name:** RXF1A  
**Offset:** 0xB8  
**Reset:** 0x00000000  
**Property:** -



**Bits 5:0 – F1AI[5:0]** Rx FIFO 1 Acknowledge Index

After the Host has read a message or a sequence of messages from Rx FIFO 1 it has to write the buffer index of the last element read from Rx FIFO 1 to F1AI. This will set the Rx FIFO 1 Get Index RXF1S.F0GI to F1AI + 1 and update the FIFO 1 Fill Level RXF1S.F1FL.

# SAM D5x/E5x Family Data Sheet

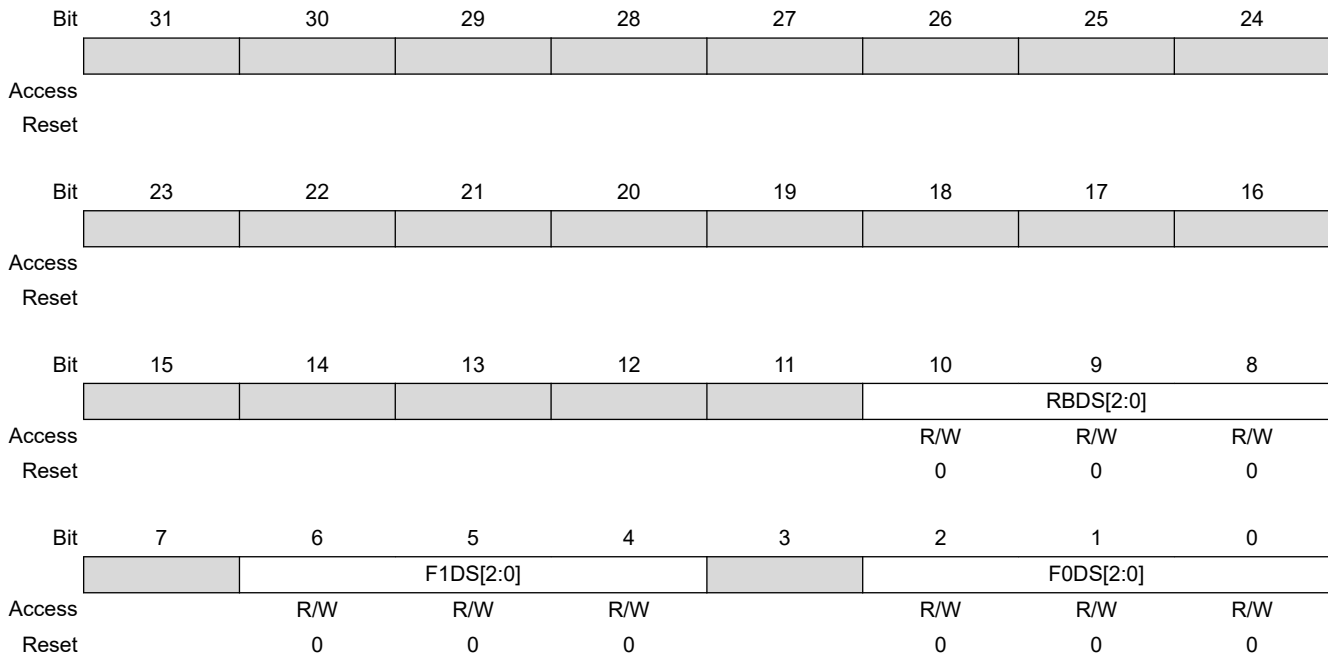
## CAN - Control Area Network

### 39.8.34 Rx Buffer / FIFO Element Size Configuration

**Name:** RXESC  
**Offset:** 0xBC  
**Reset:** 0x00000000  
**Property:** Write-restricted

This register is write-restricted and only writable if bit fields CCCR.CCE = 1 and CCCR.INIT = 1.

Configures the number of data bytes belonging to an Rx Buffer / Rx FIFO element. Data field sizes >8 bytes are intended for CAN FD operation only.



#### Bits 10:8 – RBDS[2:0] Rx Buffer Data Field Size

In case the data field size of an accepted CAN frame exceeds the data field size configured for the matching Rx Buffer, only the number of bytes as configured by RXESC are stored to the Rx Buffer element. The rest of the frame's data field is ignored.

Value	Name	Description
0x0	DATA8	8 byte data field.
0x1	DATA12	12 byte data field.
0x2	DATA16	16 byte data field.
0x3	DATA20	20 byte data field.
0x4	DATA24	24 byte data field.
0x5	DATA32	32 byte data field.
0x6	DATA48	48 byte data field.
0x7	DATA64	64 byte data field.

#### Bits 6:4 – F1DS[2:0] Rx FIFO 1 Data Field Size

In case the data field size of an accepted CAN frame exceeds the data field size configured for the matching Rx FIFO 1, only the number of bytes as configured by RXESC are stored to the Rx FIFO 1 element. The rest of the frame's data field is ignored.

# SAM D5x/E5x Family Data Sheet

## CAN - Control Area Network

Value	Name	Description
0x0	DATA8	8 byte data field.
0x1	DATA12	12 byte data field.
0x2	DATA16	16 byte data field.
0x3	DATA20	20 byte data field.
0x4	DATA24	24 byte data field.
0x5	DATA32	32 byte data field.
0x6	DATA48	48 byte data field.
0x7	DATA64	64 byte data field.

### Bits 2:0 – F0DS[2:0] Rx FIFO 0 Data Field Size

In case the data field size of an accepted CAN frame exceeds the data field size configured for the matching Rx FIFO 0, only the number of bytes as configured by RXESC are stored to the Rx FIFO 0 element. The rest of the frame's data field is ignored.

Value	Name	Description
0x0	DATA8	8 byte data field.
0x1	DATA12	12 byte data field.
0x2	DATA16	16 byte data field.
0x3	DATA20	20 byte data field.
0x4	DATA24	24 byte data field.
0x5	DATA32	32 byte data field.
0x6	DATA48	48 byte data field.
0x7	DATA64	64 byte data field.

# SAM D5x/E5x Family Data Sheet

## CAN - Control Area Network

### 39.8.35 Tx Buffer Configuration

**Name:** TXBC  
**Offset:** 0xC0  
**Reset:** 0x00000000  
**Property:** Write-restricted

This register is write-restricted and only writable if bit fields CCCR.CCE = 1 and CCCR.INIT = 1.

**Note:** Be aware that the sum of TFQS and NDTB may not be greater than 32. There is no check for erroneous configurations. The Tx Buffers section in the Message RAM starts with the dedicated Tx Buffers.

	Bit	31	30	29	28	27	26	25	24
			TFQM	TFQS[5:0]					
Access			R/W	R/W	R/W	R/W	R/W	R/W	R/W
Reset			0	0	0	0	0	0	0
	Bit	23	22	21	20	19	18	17	16
				NDTB[5:0]					
Access				R/W	R/W	R/W	R/W	R/W	R/W
Reset				0	0	0	0	0	0
	Bit	15	14	13	12	11	10	9	8
		TBSA[15:8]							
Access		R/W	R/W	R/W	R/W	R/W	R/W	R/W	R/W
Reset		0	0	0	0	0	0	0	0
	Bit	7	6	5	4	3	2	1	0
		TBSA[7:0]							
Access		R/W	R/W	R/W	R/W	R/W	R/W	R/W	R/W
Reset		0	0	0	0	0	0	0	0

#### Bit 30 – TFQM Tx FIFO/Queue Mode

Value	Description
0	Tx FIFO operation.
1	Tx Queue operation.

#### Bits 29:24 – TFQS[5:0] Transmit FIFO/Queue Size

Value	Description
0	No Tx FIFO/Queue.
1 – 32	Number of Tx Buffers used for Tx FIFO/Queue.
>32	Values greater than 32 are interpreted as 32.

#### Bits 21:16 – NDTB[5:0] Number of Dedicated Transmit Buffers

Value	Description
0	No Tx FIFO/Queue.
1 – 32	Number of Tx Buffers used for Tx FIFO/Queue.
>32	Values greater than 32 are interpreted as 32.

**Bits 15:0 – TBSA[15:0]** Tx Buffers Start Address

Start address of Tx Buffers section in Message RAM. When the CAN module addresses the Message RAM it addresses 32-bit words, not single bytes. The configurable start addresses are 32-bit word addresses, i.e. only bits 15 to 2 are evaluated, the two least significant bits are ignored. Bits 1 to 0 will always be read back as “00”.



# SAM D5x/E5x Family Data Sheet

## CAN - Control Area Network

### 39.8.36 Tx FIFO/Queue Status

**Name:** TXFQS  
**Offset:** 0xC4  
**Reset:** 0x00000000  
**Property:** Read-only

**Note:** In case of mixed configurations where dedicated Tx Buffers are combined with a Tx FIFO or a Tx Queue, the Put and Get Indexes indicate the number of the Tx Buffer starting with the first dedicated Tx Buffers. Example: For a configuration of 12 dedicated Tx Buffers and a Tx FIFO of 20 Buffers a Put Index of 15 points to the fourth buffer of the Tx FIFO.

Bit	31	30	29	28	27	26	25	24	
Access									
Reset									
Bit	23	22	21	20	19	18	17	16	
			TFQF	TFQPI[4:0]					
Access			R	R	R	R	R	R	
Reset			0	0	0	0	0	0	
Bit	15	14	13	12	11	10	9	8	
				TFGI[4:0]					
Access				R	R	R	R	R	
Reset				0	0	0	0	0	
Bit	7	6	5	4	3	2	1	0	
			TFFL[5:0]						
Access			R	R	R	R	R	R	
Reset			0	0	0	0	0	0	

**Bit 21 – TFQF** Tx FIFO/Queue Full

Value	Description
0	Tx FIFO/Queue not full.
1	Tx FIFO/Queue full.

**Bits 20:16 – TFQPI[4:0]** Tx FIFO/Queue Put Index

Tx FIFO/Queue write index pointer, range 0 to 31.

**Bits 12:8 – TFGI[4:0]** Tx FIFO/Queue Get Index

Tx FIFO read index pointer, range 0 to 31. Read as zero when Tx Queue operation is configured (TXBC.TFQM = '1').

**Bits 5:0 – TFFL[5:0]** Tx FIFO Free Level

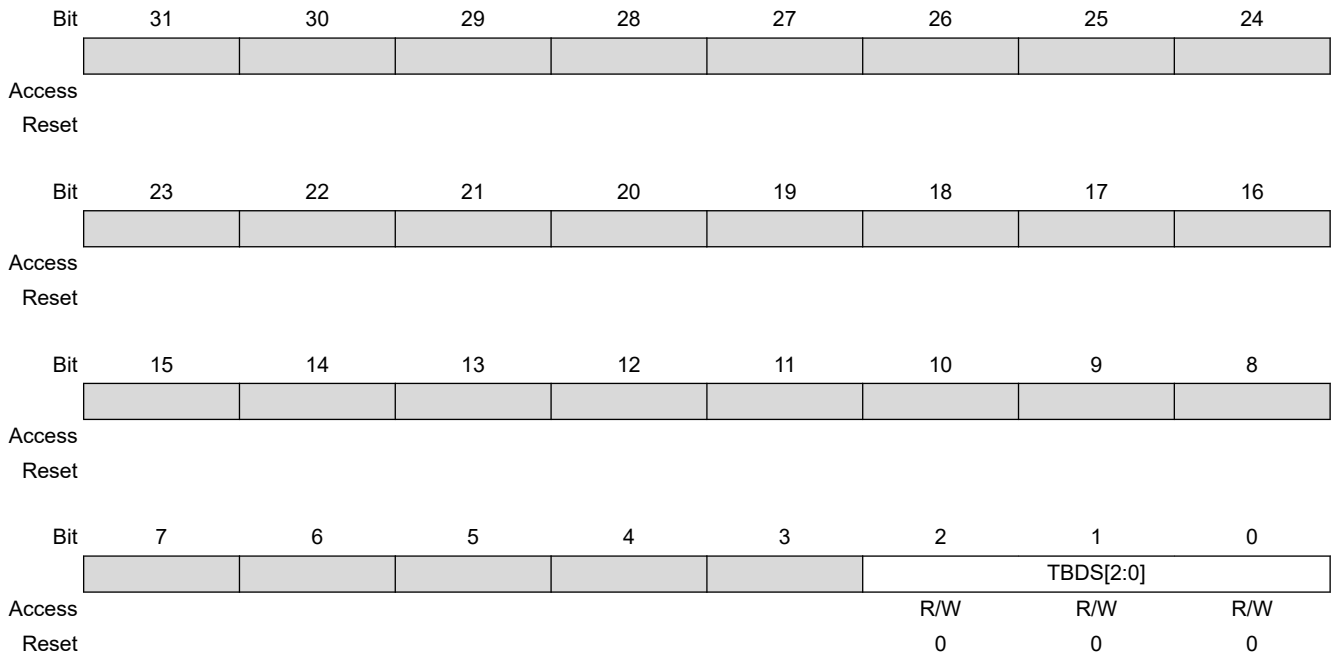
Number of consecutive free Tx FIFO elements starting from TFGI, range 0 to 32. Read as zero when Tx Queue operation is configured (TXBC.TFQM = '1').

### 39.8.37 Tx Buffer Element Size Configuration

**Name:** TXESC  
**Offset:** 0xC8  
**Reset:** 0x00000000  
**Property:** Write-restricted

This register is write-restricted and only writable if bit fields CCCR.CCE = 1 and CCCR.INIT = 1.

Configures the number of data bytes belonging to a Tx Buffer element. Data field sizes >8 bytes are intended for CAN FD operation only.



#### Bits 2:0 – TBDS[2:0] Tx Buffer Data Field Size

In case the data length code DLC of a Tx Buffer element is configured to a value higher than the Tx Buffer data field size TXESC.TBDS, the bytes not defined by the Tx Buffer are transmitted as “0xCC” (padding bytes).

Value	Name	Description
0x0	DATA8	8 byte data field.
0x1	DATA12	12 byte data field.
0x2	DATA16	16 byte data field.
0x3	DATA20	20 byte data field.
0x4	DATA24	24 byte data field.
0x5	DATA32	32 byte data field.
0x6	DATA48	48 byte data field.
0x7	DATA64	64 byte data field.

# SAM D5x/E5x Family Data Sheet

## CAN - Control Area Network

### 39.8.38 Tx Buffer Request Pending

**Name:** TXBRP  
**Offset:** 0xCC  
**Reset:** 0x00000000  
**Property:** Read-only

**Note:** TXBRP bits which are set while a Tx scan is in progress are not considered during this particular Tx scan. In case a cancellation is requested for such a Tx Buffer, this Add Request is canceled immediately, the corresponding TXBRP bit is reset.

Bit	31	30	29	28	27	26	25	24
	TRPn[31:24]							
Access	R	R	R	R	R	R	R	R
Reset	0	0	0	0	0	0	0	0
Bit	23	22	21	20	19	18	17	16
	TRPn[23:16]							
Access	R	R	R	R	R	R	R	R
Reset	0	0	0	0	0	0	0	0
Bit	15	14	13	12	11	10	9	8
	TRPn[15:8]							
Access	R	R	R	R	R	R	R	R
Reset	0	0	0	0	0	0	0	0
Bit	7	6	5	4	3	2	1	0
	TRPn[7:0]							
Access	R	R	R	R	R	R	R	R
Reset	0	0	0	0	0	0	0	0

#### Bits 31:0 – TRPn[31:0] Transmission Request Pending

Each Tx Buffer has its own Transmission Request Pending bit.

The bits are reset after a requested transmission has completed or has been cancelled via register TXBCR.

TXBRP bits are set only for those Tx Buffers configured via TXBC. After a TXBRP bit has been set, a Tx scan is started to check for the pending Tx request with the highest priority (Tx Buffer with lowest Message ID).

A cancellation request resets the corresponding transmission request pending bit of register TXBRP. In case a transmission has already been started when a cancellation is requested, this is done at the end of the transmission, regardless whether the transmission was successful or not. The cancellation request bits are reset directly after the corresponding TXBRP bit has been reset.

After a cancellation has been requested, a finished cancellation is signaled via TXBCF

- after successful transmission together with the corresponding TXBTO bit
- when the transmission has not yet been started at the point of cancellation
- when the transmission has been aborted due to lost arbitration
- when an error occurred during frame transmission

# SAM D5x/E5x Family Data Sheet

## CAN - Control Area Network

---

---

In DAR mode all transmissions are automatically canceled if they are not successful. The corresponding TXBCF bit is set for all unsuccessful transmissions.

Value	Description
0	No transmission request pending.
1	Transmission request pending.

# SAM D5x/E5x Family Data Sheet

## CAN - Control Area Network

### 39.8.39 Tx Buffer Add Request

**Name:** TXBAR  
**Offset:** 0xD0  
**Reset:** 0x00000000  
**Property:** -

**Note:** If an add request is applied for a Tx Buffer with pending transmission request (corresponding TXBRP bit is already set), this add request is ignored.

Bit	31	30	29	28	27	26	25	24
	ARn[31:24]							
Access	R/W	R/W	R/W	R/W	R/W	R/W	R/W	R/W
Reset	0	0	0	0	0	0	0	0
Bit	23	22	21	20	19	18	17	16
	ARn[23:16]							
Access	R/W	R/W	R/W	R/W	R/W	R/W	R/W	R/W
Reset	0	0	0	0	0	0	0	0
Bit	15	14	13	12	11	10	9	8
	ARn[15:8]							
Access	R/W	R/W	R/W	R/W	R/W	R/W	R/W	R/W
Reset	0	0	0	0	0	0	0	0
Bit	7	6	5	4	3	2	1	0
	ARn[7:0]							
Access	R/W	R/W	R/W	R/W	R/W	R/W	R/W	R/W
Reset	0	0	0	0	0	0	0	0

#### Bits 31:0 – ARn[31:0] Add Request

Each Tx Buffer has its own Add Request bit.

Writing a '1' will set the corresponding Add Request bit; writing a '0' has no impact. This enables the Host to set transmission requests for multiple Tx Buffers with one write to TXBAR. TXBAR bits are set only for those Tx Buffers configured via TXBC. When no Tx scan is running, the bits are reset immediately, else the bits remain set until the Tx scan process has completed.

# SAM D5x/E5x Family Data Sheet

## CAN - Control Area Network

### 39.8.40 Tx Buffer Cancellation Request

**Name:** TXBCR  
**Offset:** 0xD4  
**Reset:** 0x00000000  
**Property:** -

	Bit	31	30	29	28	27	26	25	24
		CRn[31:24]							
Access		R/W	R/W	R/W	R/W	R/W	R/W	R/W	R/W
Reset		0	0	0	0	0	0	0	0
	Bit	23	22	21	20	19	18	17	16
		CRn[23:16]							
Access		R/W	R/W	R/W	R/W	R/W	R/W	R/W	R/W
Reset		0	0	0	0	0	0	0	0
	Bit	15	14	13	12	11	10	9	8
		CRn[15:8]							
Access		R/W	R/W	R/W	R/W	R/W	R/W	R/W	R/W
Reset		0	0	0	0	0	0	0	0
	Bit	7	6	5	4	3	2	1	0
		CRn[7:0]							
Access		R/W	R/W	R/W	R/W	R/W	R/W	R/W	R/W
Reset		0	0	0	0	0	0	0	0

#### Bits 31:0 – CRn[31:0] Cancellation Request

Each Tx Buffer has its own Cancellation Request bit.

Writing a '1' will set the corresponding Cancellation Request bit; writing a '0' has no impact. This enables the Host to set cancellation requests for multiple Tx Buffers with one write to TXBCR. TXBCR bits are set only for those Tx Buffers configured via TXBC. The bits remain set until the corresponding bit of TXBRP is reset.

Value	Description
0	No cancellation pending.
1	Cancellation pending.

# SAM D5x/E5x Family Data Sheet

## CAN - Control Area Network

### 39.8.41 Tx Buffer Transmission Occurred

**Name:** TXBTO  
**Offset:** 0xD8  
**Reset:** 0x00000000  
**Property:** Read-only

	31	30	29	28	27	26	25	24
	TOn[31:24]							
Access	R	R	R	R	R	R	R	R
Reset	0	0	0	0	0	0	0	0
	23	22	21	20	19	18	17	16
	TOn[23:16]							
Access	R	R	R	R	R	R	R	R
Reset	0	0	0	0	0	0	0	0
	15	14	13	12	11	10	9	8
	TOn[15:8]							
Access	R	R	R	R	R	R	R	R
Reset	0	0	0	0	0	0	0	0
	7	6	5	4	3	2	1	0
	TOn[7:0]							
Access	R	R	R	R	R	R	R	R
Reset	0	0	0	0	0	0	0	0

**Bits 31:0 – TOn[31:0] Transmission Occurred**

Each Tx Buffer has its own Transmission Occurred bit.

The bits are set when the corresponding TXBRP bit is cleared after a successful transmission.

The bits are reset when a new transmission is requested by writing '1' to the corresponding bit of register TXBAR.

# SAM D5x/E5x Family Data Sheet

## CAN - Control Area Network

### 39.8.42 Tx Buffer Cancellation Finished

**Name:** TXBCF  
**Offset:** 0xDC  
**Reset:** 0x00000000  
**Property:** Read-only

Bit	31	30	29	28	27	26	25	24
CFn[31:24]								
Access	R	R	R	R	R	R	R	R
Reset	0	0	0	0	0	0	0	0
Bit	23	22	21	20	19	18	17	16
CFn[23:16]								
Access	R	R	R	R	R	R	R	R
Reset	0	0	0	0	0	0	0	0
Bit	15	14	13	12	11	10	9	8
CFn[15:8]								
Access	R	R	R	R	R	R	R	R
Reset	0	0	0	0	0	0	0	0
Bit	7	6	5	4	3	2	1	0
CFn[7:0]								
Access	R	R	R	R	R	R	R	R
Reset	0	0	0	0	0	0	0	0

#### Bits 31:0 – CFn[31:0] Cancellation Finished

Each Tx Buffer has its own Cancellation Finished bit.

The bits are set when the corresponding TXBRP bit is cleared after a cancellation was requested via TXBCR. In case the corresponding TXBRP bit was not set at the point of cancellation, CF is set immediately.

The bits are reset when a new transmission is requested by writing '1' to the corresponding bit of register TXBAR.



### 39.8.43 Tx Buffer Transmission Interrupt Enable

**Name:** TXBTIE  
**Offset:** 0xE0  
**Reset:** 0x00000000  
**Property:** -

	Bit	31	30	29	28	27	26	25	24
	TIEEn[31:24]								
Access	R/W	R/W	R/W	R/W	R/W	R/W	R/W	R/W	R/W
Reset	0	0	0	0	0	0	0	0	0
	Bit	23	22	21	20	19	18	17	16
	TIEEn[23:16]								
Access	R/W	R/W	R/W	R/W	R/W	R/W	R/W	R/W	R/W
Reset	0	0	0	0	0	0	0	0	0
	Bit	15	14	13	12	11	10	9	8
	TIEEn[15:8]								
Access	R/W	R/W	R/W	R/W	R/W	R/W	R/W	R/W	R/W
Reset	0	0	0	0	0	0	0	0	0
	Bit	7	6	5	4	3	2	1	0
	TIEEn[7:0]								
Access	R/W	R/W	R/W	R/W	R/W	R/W	R/W	R/W	R/W
Reset	0	0	0	0	0	0	0	0	0

#### Bits 31:0 – TIEEn[31:0] Transmission Interrupt Enable

Each Tx Buffer has its own Transmission Interrupt Enable bit.

Value	Description
0	Transmission interrupt disabled.
1	Transmission interrupt enabled.

# SAM D5x/E5x Family Data Sheet

## CAN - Control Area Network

### 39.8.44 Tx Buffer Cancellation Finished Interrupt Enable

**Name:** TXBCIE  
**Offset:** 0xE4  
**Reset:** 0x00000000  
**Property:** -

Bit	31	30	29	28	27	26	25	24
CFIEn[31:24]								
Access	R/W	R/W	R/W	R/W	R/W	R/W	R/W	R/W
Reset	0	0	0	0	0	0	0	0
Bit	23	22	21	20	19	18	17	16
CFIEn[23:16]								
Access	R/W	R/W	R/W	R/W	R/W	R/W	R/W	R/W
Reset	0	0	0	0	0	0	0	0
Bit	15	14	13	12	11	10	9	8
CFIEn[15:8]								
Access	R/W	R/W	R/W	R/W	R/W	R/W	R/W	R/W
Reset	0	0	0	0	0	0	0	0
Bit	7	6	5	4	3	2	1	0
CFIEn[7:0]								
Access	R/W	R/W	R/W	R/W	R/W	R/W	R/W	R/W
Reset	0	0	0	0	0	0	0	0

#### Bits 31:0 – CFIEn[31:0] Cancellation Finished Interrupt Enable

Each Tx Buffer has its own Cancellation Finished Interrupt Enable bit.

Value	Description
0	Cancellation finished interrupt disabled.
1	Cancellation finished interrupt enabled.

# SAM D5x/E5x Family Data Sheet

## CAN - Control Area Network

### 39.8.45 Tx Event FIFO Configuration

**Name:** TXEFC  
**Offset:** 0xF0  
**Reset:** 0x00000000  
**Property:** Write-restricted

This register is write-restricted and only writable if bit fields CCCR.CCE = 1 and CCCR.INIT = 1.

Bit	31	30	29	28	27	26	25	24
			EFWM[5:0]					
Access			R/W	R/W	R/W	R/W	R/W	R/W
Reset			0	0	0	0	0	0
Bit	23	22	21	20	19	18	17	16
			EFS[5:0]					
Access			R	R	R	R	R	R
Reset			0	0	0	0	0	0
Bit	15	14	13	12	11	10	9	8
	EFSA[15:8]							
Access	R/W	R/W	R/W	R/W	R/W	R/W	R/W	R/W
Reset	0	0	0	0	0	0	0	0
Bit	7	6	5	4	3	2	1	0
	EFSA[7:0]							
Access	R/W	R/W	R/W	R/W	R/W	R/W	R/W	R/W
Reset	0	0	0	0	0	0	0	0

#### Bits 29:24 – EFWM[5:0] Event FIFO Watermark

Value	Description
0	Watermark interrupt disabled.
1 – 32	Level for Tx Event FIFO watermark interrupt (IR.TEFW).
>32	Watermark interrupt disabled.

#### Bits 21:16 – EFS[5:0] Event FIFO Size

The Tx Event FIFO elements are indexed from 0 to EFS - 1.

Value	Description
0	Tx Event FIFO disabled
1 – 32	Number of Tx Event FIFO elements.
>32	Values greater than 32 are interpreted as 32.

#### Bits 15:0 – EFSA[15:0] Event FIFO Start Address

Start address of Tx Event FIFO in Message RAM. When the CAN module addresses the Message RAM it addresses 32-bit words, not single bytes. The configurable start addresses are 32-bit word addresses, i.e. only bits 15 to 2 are evaluated, the two least significant bits are ignored. Bits 1 to 0 will always be read back as “00”.

# SAM D5x/E5x Family Data Sheet

## CAN - Control Area Network

### 39.8.46 Tx Event FIFO Status

**Name:** TXEFS  
**Offset:** 0xF4  
**Reset:** 0x00000000  
**Property:** Read-only

	Bit	31	30	29	28	27	26	25	24	
								TEFL	EFF	
Access								R	R	
Reset								0	0	
	Bit	23	22	21	20	19	18	17	16	
					EFPI[4:0]					
Access					R	R	R	R	R	
Reset					0	0	0	0	0	
	Bit	15	14	13	12	11	10	9	8	
					EFGI[4:0]					
Access					R	R	R	R	R	
Reset					0	0	0	0	0	
	Bit	7	6	5	4	3	2	1	0	
					EFFL[4:0]					
Access					R	R	R	R	R	
Reset					0	0	0	0	0	

**Bit 25 – TEFL** Tx Event FIFO Element Lost

This bit is a copy of interrupt flag IR.TEFL. When IR.TEFL is reset, this bit is also reset.

Value	Description
0	No Tx Event FIFO element lost.
1	Tx Event FIFO element lost, also set after write attempt to Tx Event FIFO of size zero.

**Bit 24 – EFF** Event FIFO Full

Value	Description
0	Tx Event FIFO not full.
1	Tx Event FIFO full.

**Bits 20:16 – EFPI[4:0]** Event FIFO Put Index

Tx Event FIFO write index pointer, range 0 to 31.

**Bits 12:8 – EFGI[4:0]** Event FIFO Get Index

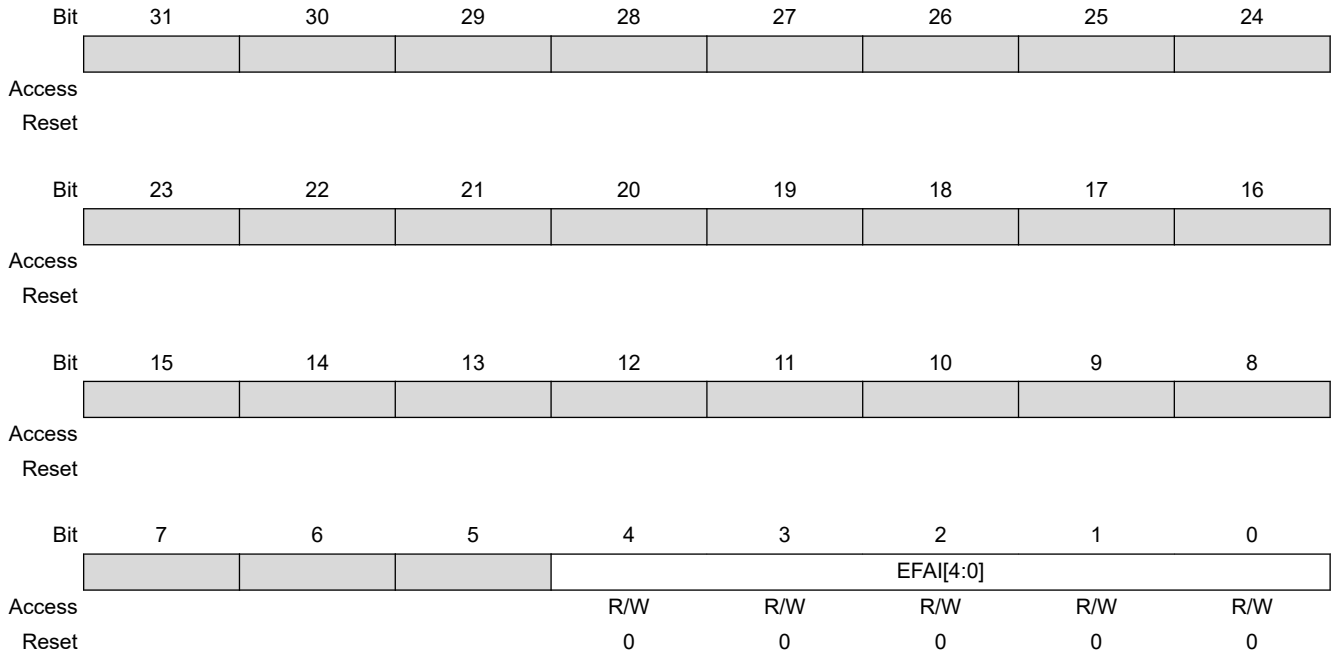
Tx Event FIFO read index pointer, range 0 to 31.

**Bits 4:0 – EFFL[4:0]** Event FIFO Fill Level

Number of elements stored in Tx Event FIFO, range 0 to 32.

### 39.8.47 Tx Event FIFO Acknowledge

**Name:** TXEFA  
**Offset:** 0xF8  
**Reset:** 0x00000000  
**Property:** -



**Bits 4:0 – EFAI[4:0]** Event FIFO Acknowledge Index

After the Host has read an element or a sequence of elements from the Tx Event FIFO it has to write the index of the last element read from Tx Event FIFO to EFAI. This will set the Tx Event FIFO Get Index TXEFS.EFGI to EFAI + 1 and update the FIFO 0 Fill Level TXEFS.EFFL.

### 39.9 Message RAM

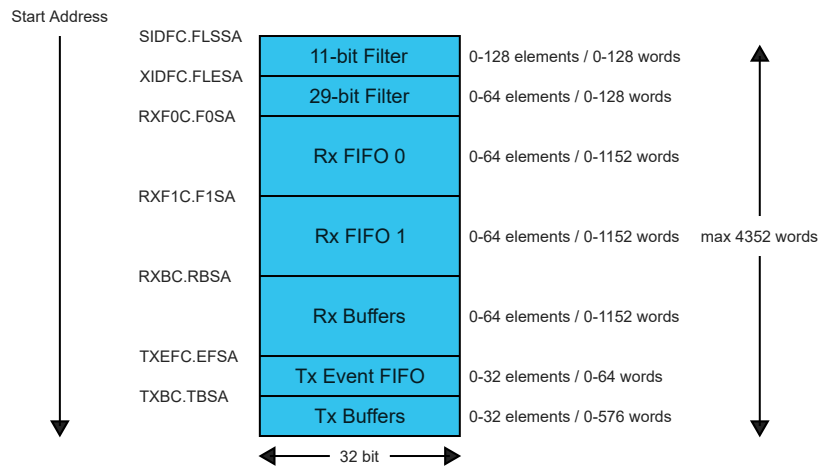
For storage of Rx/Tx messages and for storage of the filter configuration a single- or dual-ported Message RAM has to be connected to the CAN module.

#### 39.9.1 Message RAM Configuration

The Message RAM has a width of 32 bits. In case parity checking or ECC is used a respective number of bits has to be added to each word. The CAN module can be configured to allocate up to 4352 words in the Message RAM. It is not necessary to configure each of the sections listed in the figure below, nor is there any restriction with respect to the sequence of the sections.

When operated in CAN FD mode the required Message RAM size strongly depends on the element size configured for Rx FIFO 0, Rx FIFO 1, Rx Buffers, and Tx Buffers via RXESC.F0DS, RXESC.F1DS, RXESC.RBDS, and TXESC.TBDS.

**Figure 39-12. Message RAM Configuration**



When the CAN addresses the Message RAM it addresses 32-bit words, not single bytes. The configurable start addresses are 32-bit word addresses (i.e. only bits 15 to 2 are evaluated and the two LSBs are ignored).



**WARNING** The CAN does not check for erroneous configuration of the Message RAM. Especially the configuration of the start addresses of the different sections and the number of elements of each section has to be done carefully to avoid falsification or loss of data.

### 39.9.2 Rx Buffer and FIFO Element

Up to 64 Rx Buffers and two Rx FIFOs can be configured in the Message RAM. Each Rx FIFO section can be configured to store up to 64 received messages. The structure of a Rx Buffer / FIFO element is shown in the table below. The element size can be configured for storage of CAN FD messages with up to 64 bytes data field via register RXESC.

**Table 39-8. Rx Buffer and FIFO Element**

	31	30	29	28	27	26	25	24	23	22	21	20	19	18	17	16	15	14	13	12	11	10	9	8	7	6	5	4	3	2	1	0
R0	E	X	R	ID[28:0]																												
R1	A	FIDX[6:0]								F	B	DLC[3:0]			RXTS[15:0]																	
				DB3[7:0]								DB2[7:0]			DB1[7:0]						DB0[7:0]											
R3				DB7[7:0]								DB6[7:0]			DB5[7:0]						DB4[7:0]											
...				...								...			...						...											
Rn				DBm[7:0]								DBm-1[7:0]			DBm-2[7:0]						DBm-3[7:0]											

- R0 Bit 31 - ESI: Error State Indicator

- 0 : Transmitting node is error active.
- 1 : Transmitting node is error passive.
- R0 Bit 30 - XTD: Extended Identifier
  - Signals to the Host whether the received frame has a standard or extended identifier.
  - 0 : 11-bit standard identifier.
  - 1 : 29-bit extended identifier.
- R0 Bit 29 - RTR: Remote Transmission Request
  - Signals to the Host whether the received frame is a data frame or a remote frame.
  - 0 : Received frame is a data frame.
  - 1 : Received frame is a remote frame.

**Note:** There are no remote frames in CAN FD format. In case a CAN FD frame was received (EDL = '1'), bit RTR reflects the state of the reserved bit r1.
- R0 Bits 28:0 - ID[28:0]: Identifier
  - Standard or extended identifier depending on bit XTD. A standard identifier is stored into ID[28:18].
- R1 Bit 31 - ANMF: Accepted Non-matching Frame
  - Acceptance of non-matching frames may be enabled via GFC.ANFS and GFC.ANFE.
  - 0 : Received frame matching filter index FIDX.
  - 1 : Received frame did not match any Rx filter element.
- R1 Bits 30:24 - FIDX[6:0]: Filter Index
  - 0-127 : Index of matching Rx acceptance filter element (invalid if ANMF = '1').

**Note:** Range is 0 to SIDFC.LSS-1 for standard and 0 to XIDFC.LSE-1 for extended.
- R1 Bits 23:22 - Reserved
- R1 Bit 21 - FDF: FD Format
  - 0 : Standard frame format.
  - 1 : CAN FD frame format (new DLC-coding and CRC).
- R1 Bit 20 - BRS: Bit Rate Search
  - 0 : Frame received without bit rate switching.
  - 1 : Frame received with bit rate switching.
- R1 Bits 19:16 - DLC[3:0]: Data Length Code
  - 0-8 : CAN + CAN FD: received frame has 0-8 data bytes.
  - 9-15 : CAN: received frame has 8 data bytes.
  - 9-15 : CAN FD: received frame has 12/16/20/24/32/48/64 data bytes.
- R1 Bits 15:0 - RXTS[15:0]: Rx Timestamp
  - Timestamp Counter value captured on start of frame reception. Resolution depending on configuration of the Timestamp Counter Prescaler TSCC.TCP.

# SAM D5x/E5x Family Data Sheet

## CAN - Control Area Network

- R2 Bits 31:24 - DB3[7:0]: Data Byte 3
- R2 Bits 23:16 - DB2[7:0]: Data Byte 2
- R2 Bits 15:8 - DB1[7:0]: Data Byte 1
- R2 Bits 7:0 - DB0[7:0]: Data Byte 0
- R3 Bits 31:24 - DB7[7:0]: Data Byte 7
- R3 Bits 23:16 - DB6[7:0]: Data Byte 6
- R3 Bits 15:8 - DB5[7:0]: Data Byte 5
- R3 Bits 7:0 - DB4[7:0]: Data Byte 4
- ...
- Rn Bits 31:24 - DBm[7:0]: Data Byte m
- Rn Bits 23:16 - DBm-1[7:0]: Data Byte m-1
- Rn Bits 15:8 - DBm-2[7:0]: Data Byte m-2
- Rn Bits 7:0 - DBm-3[7:0]: Data Byte m-3



Depending on the configuration of RXESC, between two and sixteen 32-bit words (Rn = 3 ... 17) are used for storage of a CAN message's data field.

### 39.9.3 Tx Buffer Element

The Tx Buffers section can be configured to hold dedicated Tx Buffers as well as a Tx FIFO / Tx Queue. In case that the Tx Buffers section is shared by dedicated Tx buffers and a Tx FIFO / Tx Queue, the dedicated Tx Buffers start at the beginning of the Tx Buffers section followed by the buffers assigned to the Tx FIFO or Tx Queue. The Tx Handler distinguishes between dedicated Tx Buffers and Tx FIFO / Tx Queue by evaluating the Tx Buffer configuration TXBC.TFQS and TXBC.NDTB. The element size can be configured for storage of CAN FD messages with up to 64 bytes data field via register TXESC.

**Table 39-9. Tx Buffer Element**

	31	30	29	28	27	26	25	24	23	22	21	20	19	18	17	16	15	14	13	12	11	10	9	8	7	6	5	4	3	2	1	0
T0	E	X	R	ID[28:0]																												
T1	MM[7:0]			EFC			FDFS			BDRS			DLC[3:0]																			
T2	DB3[7:0]			DB2[7:0]			DB1[7:0]			DB0[7:0]																						
T3	DB7[7:0]			DB6[7:0]			DB5[7:0]			DB4[7:0]																						
...	...			...			...			...																						
Tn	DBm[7:0]			DBm-1[7:0]			DBm-2[7:0]			DBm-3[7:0]																						

- T0 Bit 31 - ESI: Error State Indicator
  - 0 : ESI bit in CAN FD format depends only on error passive flag.
  - 1 : ESI bit in CAN FD format transmitted recessive.



# SAM D5x/E5x Family Data Sheet

## CAN - Control Area Network

**Note:** The ESI bit of the transmit buffer is OR'ed with the error passive flag to decide the value of the ESI bit in the transmitted FD frame. As required by the CAN FD protocol specification, an error active node may optionally transmit the ESI bit recessive, but an error passive node will always transmit the ESI bit recessive.

- T0 Bit 30 - XTD: Extended Identifier
  - 0 : 11-bit standard identifier.
  - 1 : 29-bit extended identifier.
- T0 Bit 29 - RTR: Remote Transmission Request
  - 0 : Transmit data frame.
  - 1 : Transmit remote frame.

**Note:** When RTR = '1', the CAN transmits a remote frame according to ISO 11898-1, even if CCCR.CME enables the transmission in CAN FD format.

- T0 Bits 28:0 - ID[28:0]: Identifier
  - Standard or extended identifier depending on bit XTD. A standard identifier is stored into ID[28:18].
- T1 Bits 31:24 - MM[7:0]: Message Marker
  - Written by CPU during Tx Buffer configuration. Copied into Tx Event FIFO element for identification of Tx message status.
- T1 Bit 23 - EFC: Event FIFO Control
  - 0 : Don't store Tx events.
  - 1 : Store Tx events.
- T1 Bit 22 - Reserved
- TR1 Bit 21 - FDF: FD Format
  - 0 : Frame transmitted in Classic CAN format.
  - 1 : Frame transmitted in CAN FD format.
- T1 Bit 20 - BRS: Bit Rate Search
  - 0 : CAN FD frames transmitted without bit rate switching.
  - 1 : CAN FD frames transmitted with bit rate switching.

**Note:** Bits ESI, FDF, and BRS are only evaluated when CAN FD operation is enabled CCCR.FDOE = '1'. Bit BRS is only evaluated when in addition CCCR.BRSE = '1'.

- T1 Bits 19:16 - DLC[3:0]: Data Length Code
  - 0-8 : CAN + CAN FD: received frame has 0-8 data bytes.
  - 9-15 : CAN: received frame has 8 data bytes.
  - 9-15 : CAN FD: received frame has 12/16/20/24/32/48/64 data bytes.
- T1 Bits 15:0 - Reserved
- T2 Bits 31:24 - DB3[7:0]: Data Byte 3
- T2 Bits 23:16 - DB2[7:0]: Data Byte 2
- T2 Bits 15:8 - DB1[7:0]: Data Byte 1
- T2 Bits 7:0 - DB0[7:0]: Data Byte 0
- T3 Bits 31:24 - DB7[7:0]: Data Byte 7

# SAM D5x/E5x Family Data Sheet

## CAN - Control Area Network

- T3 Bits 23:16 - DB6[7:0]: Data Byte 6
- T3 Bits 15:8 - DB5[7:0]: Data Byte 5
- T3 Bits 7:0 - DB4[7:0]: Data Byte 4
- ...
- Tn Bits 31:24 - DBm[7:0]: Data Byte m
- Tn Bits 23:16 - DBm-1[7:0]: Data Byte m-1
- Tn Bits 15:8 - DBm-2[7:0]: Data Byte m-2
- Tn Bits 7:0 - DBm-3[7:0]: Data Byte m-3

**Note:** Depending on the configuration of TXESC, between two and sixteen 32-bit words (Tn = 3 ... 17) are used for storage of a CAN message's data field.

### 39.9.4 Tx Event FIFO Element

Each element stores information about transmitted messages. By reading the Tx Event FIFO the Host CPU gets this information in the order the messages were transmitted. Status information about the Tx Event FIFO can be obtained from register TXEFS.

**Table 39-10. Tx Event FIFO Element**

	31	30	29	28	27	26	25	24	23	22	21	20	19	18	17	16	15	14	13	12	11	10	9	8	7	6	5	4	3	2	1	0
E0	E S I	X T D	R T R	ID[28:0]																												
E1	MM[7:0]							ET [1:0]	F D F	B R S	DLC[3:0]			TXTS[15:0]																		

- E0 Bit 31 - ESI: Error State Indicator
  - 0 : Transmitting node is error active.
  - 1 : Transmitting node is error passive.
- E0 Bit 30 - XTD: Extended Identifier
  - 0 : 11-bit standard identifier.
  - 1 : 29-bit extended identifier.
- E0 Bit 29 - RTR: Remote Transmission Request
  - 0 : Received frame is a data frame.
  - 1 : Received frame is a remote frame.
- E0 Bits 28:0 - ID[28:0]: Identifier
  - Standard or extended identifier depending on bit XTD. A standard identifier is stored into ID[28:18].
- E1 Bits 31:24 - MM[7:0]: Message Marker
  - Copied from Tx Buffer into Tx Event FIFO element for identification of Tx message status.
- E1 Bits 23:22 - ET[1:0]: Event Type
  - This field defines the event type.

**Table 39-11. Event Type**

Value	Name	Description
0x0 or 0x3	RES	Reserved
0x1	TXE	Tx event
0x2	TXC	Transmission in spite of cancellation (always set for transmission in DAR mode)

- E1 Bit 21 - FDF: FD Format
  - 0 : Standard frame format.
  - 1 : CAN FD frame format (new DLC-coding and CRC).
- E1 Bit 20 - BRS: Bit Rate Search
  - 0 : Frame received without bit rate switching.
  - 1 : Frame received with bit rate switching.
- E1 Bits 19:16 - DLC[3:0]: Data Length Code
  - 0-8 : CAN + CAN FD: received frame has 0-8 data bytes.
  - 9-15 : CAN: received frame has 8 data bytes.
  - 9-15 : CAN FD: received frame has 12/16/20/24/32/48/64 data bytes.
- E1 Bits 15:0 - TXTS[15:0]: Tx Timestamp
  - Timestamp Counter value captured on start of frame transmission. Resolution depending on configuration of the Timestamp Counter Prescaler TSCC.TCP.

### 39.9.5 Standard Message ID Filter Element

Up to 128 filter elements can be configured for 11-bit standard IDs. When accessing a Standard Message ID Filter element, its address is the Filter List Standard Start Address SIDFC.FLSSA plus the index of the filter element (0 ... 127).

**Table 39-12. Standard Message ID Filter Element**

	31	30	29	28	27	26	25	24	23	22	21	20	19	18	17	16	15	14	13	12	11	10	9	8	7	6	5	4	3	2	1	0
S0	SFT [1:0]		SFEC [2:0]		SFID1[10:0]										SFID2[10:0]																	

- Bits 31:30 - SFT[1:0]: Standard Filter Type
  - This field defines the standard filter type.

**Table 39-13. Standard Filter Type**

Value	Name	Description
0x0	RANGE	Range filter from SFID1 to SFID2 (SFID2 >= SFID1)
0x1	DUAL	Dual ID filter for SFID1 or SFID2
0x2	CLASSIC	Classic filter: SFID1 = filter, SFID2 = mask
0x3	RES	Reserved

# SAM D5x/E5x Family Data Sheet

## CAN - Control Area Network

- Bits 29:27 - SFEC[2:0]: Standard Filter Element Configuration

All enabled filter elements are used for acceptance filtering of standard frames. Acceptance filtering stops at the first matching enabled filter element or when the end of the filter list is reached. If SFEC = “100”, “101”, or “110” a match sets interrupt flag IR.HPM and, if enabled, an interrupt is generated. In this case register HPMS is updated with the status of the priority match.

**Table 39-14. Standard Filter Element Configuration**

Value	Name	Description
0x0	DISABLE	Disable filter element
0x1	STF0M	Store in Rx FIFO 0 if filter matches
0x2	STF1M	Store in Rx FIFO 1 if filter matches
0x3	REJECT	Reject ID if filter matches
0x4	PRIORITY	Set priority if filter matches.
0x5	PRIF0M	Set priority and store in FIFO 0 if filter matches.
0x6	PRIF1M	Set priority and store in FIFO 1 if filter matches.
0x7	STRXBUF	Store into Rx Buffer or as debug message, configuration of SFT[1:0] ignored.

- Bits 26:16 - SFID1[10:0]: Standard Filter ID 1

First ID of standard ID filter element.

When filtering for Rx Buffers or for debug messages this field defines the ID of a standard message to be stored. The received identifiers must match exactly, no masking mechanism is used.

- Bits 15:11 - Reserved
- Bits 10:0 - SFID2[10:0]: Standard Filter ID 2

This bit field has a different meaning depending on the configuration of SFEC.

1. SFEC = “001” ... “110”: Second ID of standard ID filter element.
2. SFEC = “111”: Filter for Rx Buffers or for debug messages.

SFID2[10:9] decides whether the received message is stored into an Rx Buffer or treated as message A, B, or C of the debug message sequence.

00 = Store message into an Rx Buffer

01 = Debug Message A

10 = Debug Message B

11 = Debug Message C

SFID2[8:6] is used to control the filter event pins at the Extension Interface. A ‘1’ at the respective bit position enables generation of a pulse at the related filter event pin with the duration of one CLK\_CAN\_APB period in case the filter matches.

SFID2[5:0] defines the offset to the Rx Buffer Start Address RXBC.RBSA for storage of a matching message.

### 39.9.6 Extended Message ID Filter Element

Up to 64 filter elements can be configured for 29-bit extended IDs. When accessing an Extended Message ID Filter element, its address is the Filter List Extended Start Address XIDFC.FLESA plus two times the index of the filter element (0...63).

# SAM D5x/E5x Family Data Sheet

## CAN - Control Area Network

**Table 39-15. Extended Message ID Filter Element**

	31	30	29	28	27	26	25	24	23	22	21	20	19	18	17	16	15	14	13	12	11	10	9	8	7	6	5	4	3	2	1	0
F0	EFEC [2:0]		EFID1[28:0]																													
F1	EFT [1:0]		EFID2[28:0]																													

- F0 Bits 31:29 - EFEC[2:0]: Extended Filter Element Configuration

All enabled filter elements are used for acceptance filtering of extended frames. Acceptance filtering stops at the first matching enabled filter element or when the end of the filter list is reached. If EFEC = “100”, “101”, or “110” a match sets interrupt flag IR.HPM and, if enabled, an interrupt is generated. In this case register HPMS is updated with the status of the priority match.

**Table 39-16. Extended Filter Element Configuration**

Value	Name	Description
0x0	DISABLE	Disable filter element.
0x1	STF0M	Store in Rx FIFO 0 if filter matches.
0x2	STF1M	Store in Rx FIFO 1 if filter matches.
0x3	REJECT	Reject ID if filter matches.
0x4	PRIORITY	Set priority if filter matches.
0x5	PRIF0M	Set priority and store in FIFO 0 if filter matches.
0x6	PRIF1M	Set priority and store in FIFO 1 if filter matches.
0x7	STRXBUF	Store into Rx Buffer or as debug message, configuration of EFT[1:0] ignored.

- F0 Bits 28:0 - EFID1[28:0]: Extended Filter ID 1  
First ID of extended ID filter element.  
When filtering for Rx Buffers or for debug messages this field defines the ID of a extended message to be stored. The received identifiers must match exactly, only XIDAM masking mechanism is used.
- F1 Bits 31:30 - EFT[1:0]: Extended Filter Type  
This field defines the extended filter type.

**Table 39-17. Extended Filter Type**

Value	Name	Description
0x0	RANGEM	Range filter from EFID1 to EFID2 (EFID2 >= EFID1).
0x1	DUAL	Dual ID filter for EFID1 or EFID2.
0x2	CLASSIC	Classic filter: EFID1 = filter, EFID2 = mask.
0x3	RANGE	Range filter from EFID1 to EFID2 (EFID2 >= EFID1), XIDAM mask not applied.

- F1 Bits 28:0 - EFID2[28:0]: Extended Filter ID 2

# SAM D5x/E5x Family Data Sheet

## CAN - Control Area Network

---

This bit field has a different meaning depending on the configuration of EFEC.

- 1) EFEC = "001" ... "110" Second ID of standard ID filter element.
- 2) EFEC = "111" Filter for Rx Buffers or for debug messages.

EFID2[10:9] decides whether the received message is stored into an Rx Buffer or treated as message A, B, or C of the debug message sequence.

00 = Store message into an Rx Buffer

01 = Debug Message A

10 = Debug Message B

11 = Debug Message C

EFID2[8:6] is used to control the filter event pins at the Extension Interface. A '1' at the respective bit position enables generation of a pulse at the related filter event pin with the duration of one CLK\_CAN\_APB period in case the filter matches.

EFID2[5:0] defines the offset to the Rx Buffer Start Address RXBC.RBSA for storage of a matching message.

## 40. SD/MMC Host Controller (SDHC)

### 40.1 Overview

The SD/MMC Host Controller (SDHC) supports the embedded MultiMedia Card (e.MMC) Specification, the SD Memory Card Specification, and the SDIO Specification. It is compliant with the SD Host Controller Standard specifications. Refer to [40.1.1 Reference Documents](#) for details.

The SDHC includes the register set defined in the “SD Host Controller Simplified Specification V3.00” and additional registers to manage e.MMC devices and enhanced features.

The SDHC is clocked by up to three clocks (bus clock, SDHC core clock, and a slow clock for certain functions). Both the MCLK and GCLK must be configured before the SDHC can be used.

The SAM D5x/E5x provides two instances of the SDHC, SDHC0 and SDHC1.

#### Related Links

[40.3.1 Block Diagram](#)

### 40.1.1 Reference Documents

Name	Link
SD Host Controller Simplified Specification V3.00	<a href="https://www.sdcard.org">https://www.sdcard.org</a>
SDIO Simplified Specification V3.00	
Physical Layer Simplified Specification V3.01	
Embedded MultiMedia Card (e.MMC) Electrical Standard 4.51	<a href="http://www.jedec.org">http://www.jedec.org</a>

### 40.2 Features

- Compatibility:
  - SD Host Controller Standard Specification
  - MultiMedia Card Specification
  - SD Memory Card Specification
  - SDIO Specification Version

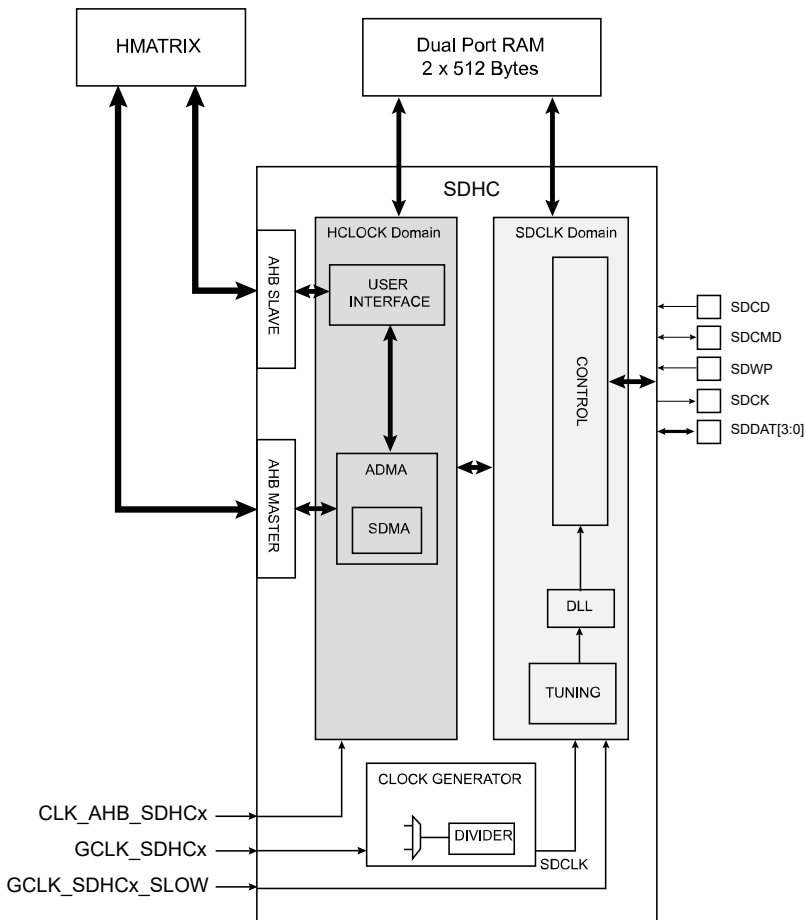
Refer to [40.1.1 Reference Documents](#) for details.

- Support for 1-bit/ 4-bit SD/SDIO Devices
- Support for 1-bit/4-bit e.MMC Devices
- Support for SD/SDIO Default Speed (Maximum SDCLK Frequency = 25 MHz)
- Support for SD/SDIO High Speed (Maximum SDCLK Frequency = 50 MHz)
- Support for e.MMC Default Speed (Maximum SDCLK Frequency = 26 MHz)
- e.MMC Boot Operation Mode Support
- Support for Block Size from 1 to 512 bytes
- Support for Stream, Block and Multi-block Data Read and Write – Advanced DMA and SDMA Capability

- Internal 1024-byte Dual Port RAM
- Support for both synchronous and asynchronous abort
- Supports for SDIO Card Interrupt

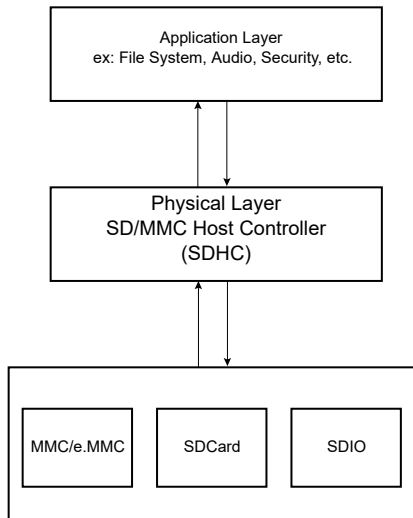
### 40.3 Block Diagrams

#### 40.3.1 Block Diagram





### 40.3.2 Application Block Diagram



### 40.4 Signal Description

Signal Name	Type	Description
SDCD	Input	SD Card / SDIO /e.MMC Card Detect
SDCMD	I/O	SD Card / SDIO /e.MMC Command/Response Line
SDWP	Input	SD Card Connector Write Protect Signal
SDCK	Output	SD Card / SDIO /e.MMC Clock Signal
SDDAT[3:0]	I/O	SD Card / SDIO /e.MMC data lines

### 40.5 Product Dependencies

#### 40.5.1 I/O Lines

In order to use the I/O lines, the I/O pins must be configured using the IO Pin Controller (PORT).

#### 40.5.2 Power Management

This peripheral can continue to operate in any sleep mode where its source clock is running. Refer to PM – Power Manager for details on the different sleep modes.

#### 40.5.3 Clocks

The peripheral is using two generic clocks and one bus clock.

The clock for the SDHC bus interface (CLK\_AHB\_SDHC) is enabled and disabled by the Main Clock Controller. The default state of CLK\_AHB\_SDHC can be found in the Peripheral Clock Masking section.

The two generic clocks are:

- The core clock GCLK\_SDHCx is required to clock the SDHC core.
- The slow clock GCLK\_SDHCx\_SLOW is only required for certain functions. When this clock is required, GCLK\_SDHCx must be enabled.

These clocks must be configured and enabled in the Generic Clock Controller (GCLK) before using the SDHC. The generic clocks are asynchronous to the user interface clock (CLK\_SDHCx\_AHB). Due to this asynchronicity, writing to certain registers will require synchronization between the clock domains.

### Related Links

[15. MCLK – Main Clock](#)

#### 40.5.4 DMA

Not applicable.

#### 40.5.5 Interrupts

The interrupt request line is connected to the Interrupt Controller. In order to use interrupt requests of this peripheral, the Interrupt Controller (NVIC) must be configured first.

#### 40.5.6 Events

Not applicable.

### 40.6 Functional Description

#### 40.6.1 SD/SDIO Operating Mode

This peripheral is fully compliant with the "SD Host Controller Simplified Specification V3.00" for SD/SDIO devices. Refer to this specification for configuration.

Refer to "Physical Layer Simplified Specification V3.01" and "SDIO Simplified Specification V3.00" for SD/SDIO management.

### Related Links

[40.1.1 Reference Documents](#)

#### 40.6.2 e.MMC Operating Mode

This peripheral supports e.MMC devices management. As the "SD Host Controller Simplified Specification V3.00" does not apply to e.MMC devices, some registers have been added to those described in this specification in order to manage e.MMC devices. Most of the registers described in the "SD Host Controller Simplified Specification V3.00" must be used for e.MMC management, but e.MMC-specific features are managed using MC1R and MC2R.

### Related Links

[40.1.1 Reference Documents](#)

# SAM D5x/E5x Family Data Sheet

## SD/MMC Host Controller ...

### 40.7 Register Summary

Offset	Name	Bit Pos.									
0x00	SSAR	7:0	ARG2[7:0]								
		15:8	ARG2[15:8]								
		23:16	ARG2[23:16]								
		31:24	ARG2[31:24]								
0x04	BSR	7:0	BLKSIZE[7:0]								
		15:8	BOUNDARY[2:0]						BLKSIZE[9:8]		
0x06	BCR	7:0	BLKCNT[7:0]								
		15:8	BLKCNT[15:8]								
0x08	ARG1R	7:0	ARG1[7:0]								
		15:8	ARG1[15:8]								
		23:16	ARG1[23:16]								
		31:24	ARG1[31:24]								
0x0C	TMR	7:0			MSBSEL	DTDSEL	ACMDEN[1:0]		BCEN	DMAEN	
		15:8									
0x0E	CR	7:0	CMDTYP[1:0]		DPSEL	CMDICEN	CMDCCEN			RESPTYP[1:0]	
		15:8			CMDIDX[5:0]						
0x10	RR0	7:0	CMDRESP[7:0]								
		15:8	CMDRESP[15:8]								
		23:16	CMDRESP[23:16]								
		31:24	CMDRESP[31:24]								
0x14	RR1	7:0	CMDRESP[7:0]								
		15:8	CMDRESP[15:8]								
		23:16	CMDRESP[23:16]								
		31:24	CMDRESP[31:24]								
0x18	RR2	7:0	CMDRESP[7:0]								
		15:8	CMDRESP[15:8]								
		23:16	CMDRESP[23:16]								
		31:24	CMDRESP[31:24]								
0x1C	RR3	7:0	CMDRESP[7:0]								
		15:8	CMDRESP[15:8]								
		23:16	CMDRESP[23:16]								
		31:24	CMDRESP[31:24]								
0x20	BDPR	7:0	BUFDATA[7:0]								
		15:8	BUFDATA[15:8]								
		23:16	BUFDATA[23:16]								
		31:24	BUFDATA[31:24]								
0x24	PSR	7:0					RTREQ	DLACT	CMDINHDL	CMDINHCL	
		15:8					BUFRDEN	BUFWREN	RTACT	WTACT	
		23:16	DATLL[3:0]				WRPPL	CARDDDL	CARDSS	CARDINS	
		31:24								CMDLL	
0x28	HC1R	7:0	CARDSEL	CARDDTL		DMASEL[1:0]		HSEN	DW	LEDCTRL	
0x29	PCR	7:0				SDBVSEL[2:0]			SDBPWR		
0x2A	BGCR	7:0				INTBG	RWCTRL	CONTR	STPBGR		

# SAM D5x/E5x Family Data Sheet

## SD/MMC Host Controller ...

.....continued

Offset	Name	Bit Pos.									
0x2B	WCR	7:0						WKENCREM	WKENCINS	WKENCINT	
0x2C	CCR	7:0	USDCLKFSEL[1:0]	CLKGSEL				SDCLKEN	INTCLKS	INTCLKEN	
		15:8	SDCLKFSEL[7:0]								
0x2E	TCR	7:0						DTCVAL[3:0]			
0x2F	SRR	7:0						SWRSTDAT	SWRSTCMD	SWRSTALL	
0x30	NISTR	7:0	CREM	CINS	BRDRDY	BWRRDY	DMAINT	BLKGE	TRFC	CMDC	
		15:8	ERRINT	BOOTAR						CINT	
0x32	EISTR	7:0	CURLIM	DATEND	DATCRC	DATTEO	CMDIDX	CMDEND	CMDCRC	CMDTEO	
		15:8				BOOTAE			ADMA	ACMD	
0x34	NISTER	7:0	CREM	CINS	BRDRDY	BWRRDY	DMAINT	BLKGE	TRFC	CMDC	
		15:8		BOOTAR						CINT	
0x36	EISTER	7:0	CURLIM	DATEND	DATCRC	DATTEO	CMDIDX	CMDEND	CMDCRC	CMDTEO	
		15:8				BOOTAE			ADMA	ACMD	
0x38	NISIER	7:0	CREM	CINS	BRDRDY	BWRRDY	DMAINT	BLKGE	TRFC	CMDC	
		15:8		BOOTAR						CINT	
0x3A	EISIER	7:0	CURLIM	DATEND	DATCRC	DATTEO	CMDIDX	CMDEND	CMDCRC	CMDTEO	
		15:8				BOOTAE			ADMA	ACMD	
0x3C	ACESR	7:0	CMDNI			ACMDIDX	ACMDEND	ACMDCRC	ACMDTEO	ACMD12NE	
		15:8									
0x3E	HC2R - EMMC	7:0	SCLKSEL	EXTUN	DRVSEL[1:0]			HS200EN[3:0]			
		15:8	PVALEN								
0x3E	HC2R - DEFAULT	7:0	SCLKSEL	EXTUN	DRVSEL[1:0]		VS18EN	UHSMS[2:0]			
		15:8	PVALEN	ASINTEN							
0x40	CA0R	7:0	TEOCLKU		TEOCLKF[5:0]						
		15:8	BASECLKF[7:0]								
		23:16	SRSUP	SDMASUP	HSSUP		ADMA2SUP	ED8SUP		MAXBLKL	
		31:24	SLTYPE[1:0]		ASINTSUP	SB64SUP		V18VSUP	V30VSUP	V33VSUP	
0x44	CA1R	7:0		DRVDSUP	DRVCSUP	DRVASUP		DDR50SUP	SDR104SUP	SDR50SUP	
		15:8			TSDR50		TCNTRT[3:0]				
		23:16	CLKMULT[7:0]								
		31:24									
0x48	MCCAR	7:0	MAXCUR33V[7:0]								
		15:8	MAXCUR30V[7:0]								
		23:16	MAXCUR18V[7:0]								
		31:24									
0x4C ... 0x4F	Reserved										
0x50	FERACES	7:0	CMDNI			ACMDIDX	ACMDEND	ACMDCRC	ACMDTEO	ACMD12NE	
		15:8									
0x52	FEREIS	7:0	CURLIM	DATEND	DATCRC	DATTEO	CMDIDX	CMDEND	CMDCRC	CMDTEO	
		15:8				BOOTAE			ADMA	ACMD	
0x54	AESR	7:0						LMIS	ERRST[1:0]		

# SAM D5x/E5x Family Data Sheet

## SD/MMC Host Controller ...

.....continued											
Offset	Name	Bit Pos.									
0x55 ... 0x57	Reserved										
0x58	ASAR	7:0	ADMASA[7:0]								
		15:8	ADMASA[15:8]								
		23:16	ADMASA[23:16]								
		31:24	ADMASA[31:24]								
0x5C ... 0x5F	Reserved										
0x60	PVR0	7:0	SDCLKFSEL[7:0]								
		15:8							CLKGSEL	SDCLKFSEL[9:8]	
0x62	PVR1	7:0	SDCLKFSEL[7:0]								
		15:8							CLKGSEL	SDCLKFSEL[9:8]	
0x64	PVR2	7:0	SDCLKFSEL[7:0]								
		15:8							CLKGSEL	SDCLKFSEL[9:8]	
0x66	PVR3	7:0	SDCLKFSEL[7:0]								
		15:8							CLKGSEL	SDCLKFSEL[9:8]	
0x68	PVR4	7:0	SDCLKFSEL[7:0]								
		15:8							CLKGSEL	SDCLKFSEL[9:8]	
0x6A	PVR5	7:0	SDCLKFSEL[7:0]								
		15:8							CLKGSEL	SDCLKFSEL[9:8]	
0x6C	PVR6	7:0	SDCLKFSEL[7:0]								
		15:8							CLKGSEL	SDCLKFSEL[9:8]	
0x6E	PVR7	7:0	SDCLKFSEL[7:0]								
		15:8							CLKGSEL	SDCLKFSEL[9:8]	
0x70 ... 0xFB	Reserved										
0xFC	SISR	7:0	INTSSL[7:0]								
		15:8									
0xFE	HCVR	7:0	SVER[7:0]								
		15:8	VVER[7:0]								
0x0100 ... 0x01FF	Reserved										
0x0200	APSR	7:0								HDATLL[3:0]	
		15:8									
		23:16									
		31:24									
0x0204	MC1R	7:0	FCD	RSTN	BOOTA	OPD	DDR	CMDTYP[1:0]			
0x0205	MC2R	7:0							ABOOT	SRESP	
0x0206 ... 0x0207	Reserved										

# SAM D5x/E5x Family Data Sheet

## SD/MMC Host Controller ...

.....continued

Offset	Name	Bit Pos.								
0x0208	ACR	7:0							BMAX[1:0]	
		15:8								
		23:16								
		31:24								
0x020C	CC2R	7:0							FSDCLKD	
		15:8								
		23:16								
		31:24								
0x0210 ... 0x022F	Reserved									
0x0230	CACR	7:0							CAPWREN	
		15:8	KEY[7:0]							
		23:16								
		31:24								
0x0234	DBGCR	7:0							NIDBG	
		15:8								

### 40.8 Register Description

### 40.8.1 SDMA System Address / Argument 2 Register

**Name:** SSAR  
**Offset:** 0x00  
**Reset:** 0x00000000  
**Property:** -

This register contains the physical system memory address used for SDMA transfers or the second argument for Auto CMD23.

Bit	31	30	29	28	27	26	25	24
	ARG2[31:24]							
Access	R/W	R/W	R/W	R/W	R/W	R/W	R/W	R/W
Reset	0	0	0	0	0	0	0	0
Bit	23	22	21	20	19	18	17	16
	ARG2[23:16]							
Access	R/W	R/W	R/W	R/W	R/W	R/W	R/W	R/W
Reset	0	0	0	0	0	0	0	0
Bit	15	14	13	12	11	10	9	8
	ARG2[15:8]							
Access	R/W	R/W	R/W	R/W	R/W	R/W	R/W	R/W
Reset	0	0	0	0	0	0	0	0
Bit	7	6	5	4	3	2	1	0
	ARG2[7:0]							
Access	R/W	R/W	R/W	R/W	R/W	R/W	R/W	R/W
Reset	0	0	0	0	0	0	0	0

#### Bits 31:0 – ARG2[31:0] SDMA System Address/Argument 2

The function of this bit field is depending on the operation mode:

For a SDMA transfer, this field is the system memory address. When the peripheral stops an SDMA transfer, this field points to the system address of the next contiguous data position. This field can be accessed only if no transaction is executing (i.e., after a transaction has stopped). Read operations during transfers may return an invalid value. An interrupt can be generated to instruct the software to update this field. Writing the next system address of the next data position restarts the SDMA transfer. When executing Auto CMD23, this field is used with Auto CMD23 to set a 32-bit block count value to the CMD23 argument. If Auto CMD23 is used with ADMA, the full 32-bit block count value can be used. If Auto CMD23 is used without ADMA, the available block count value is limited by BCR. In this case, 65535 blocks is the maximum value.

### 40.8.2 Block Size Register

**Name:** BSR  
**Offset:** 0x04  
**Reset:** 0x0000  
**Property:** -

	Bit	15	14	13	12	11	10	9	8
		BOUNDARY[2:0]						BLKSIZE[9:8]	
Access								R/W	R/W
Reset			0	0	0			0	0
	Bit	7	6	5	4	3	2	1	0
		BLKSIZE[7:0]							
Access		R/W	R/W	R/W	R/W	R/W	R/W	R/W	R/W
Reset		0	0	0	0	0	0	0	0

#### Bits 14:12 – BOUNDARY[2:0] SDMA Buffer Boundary

This field specifies the size of the contiguous buffer in the system memory. The SDMA transfer waits at every boundary specified by this field and the peripheral generates the DMA Interrupt to instruct the software to update SSAR. If this field is set to 0 (buffer size = 4 Kbytes), the lowest 12 bits of SSAR.ADDRESS point to data in the contiguous buffer, and the upper 20 bits point to the location of the buffer in the system memory. This function is active when the DMA Enable bit in the Transfer Mode Register (TMR.DMAEN) is '1'.

Value	Name	Description
0	4K	4-Kbyte boundary
1	8K	8-Kbyte boundary
2	16K	16-Kbyte boundary
3	32K	32-Kbyte boundary
4	64K	64-Kbyte boundary
5	128K	128-Kbyte boundary
6	256k	256-Kbyte boundary
7	512K	512-Kbyte boundary

#### Bits 9:0 – BLKSIZE[9:0] Transfer Block Size

This field specifies the block size of data transfers for CMD17, CMD18, CMD24, CMD25 and CMD53. Values ranging from 1 to 512 can be set. It can be accessed only if no transaction is executing (i.e., after a transaction has stopped). Read operations during transfers may return an invalid value, and write operations are ignored.



### 40.8.3 Block Count Register

**Name:** BCR  
**Offset:** 0x06  
**Reset:** 0x0000  
**Property:** -

	Bit	15	14	13	12	11	10	9	8
		BLKCNT[15:8]							
Access		R/W	R/W	R/W	R/W	R/W	R/W	R/W	R/W
Reset		0	0	0	0	0	0	0	0
	Bit	7	6	5	4	3	2	1	0
		BLKCNT[7:0]							
Access		R/W	R/W	R/W	R/W	R/W	R/W	R/W	R/W
Reset		0	0	0	0	0	0	0	0

**Bits 15:0 – BLKCNT[15:0]** Block Count for Current Transfer

This field is used only if TMR.BCEN (Block Count Enable) is set to 1 and is valid only for multiple block transfers. BLKCNT is the number of blocks to be transferred and it must be set to a value between 1 and the maximum block count. The peripheral decrements the block count after each block transfer and stops when the count reaches 0. When this field is set to 0, no data block is transferred.

This register should be accessed only when no transaction is executing (i.e., after transactions are stopped). During data transfer, read operations on this register may return an invalid value and write operations are ignored.

When a suspend command is completed, the number of blocks yet to be transferred can be determined by reading this register. Before issuing a resume command, the previously saved block count is restored.

### 40.8.4 Argument 1 Register

**Name:** ARG1R  
**Offset:** 0x08  
**Reset:** 0x00000000  
**Property:** Read/Write

	Bit	31	30	29	28	27	26	25	24
		ARG1[31:24]							
Access		R/W	R/W	R/W	R/W	R/W	R/W	R/W	R/W
Reset		0	0	0	0	0	0	0	0
	Bit	23	22	21	20	19	18	17	16
		ARG1[23:16]							
Access		R/W	R/W	R/W	R/W	R/W	R/W	R/W	R/W
Reset		0	0	0	0	0	0	0	0
	Bit	15	14	13	12	11	10	9	8
		ARG1[15:8]							
Access		R/W	R/W	R/W	R/W	R/W	R/W	R/W	R/W
Reset		0	0	0	0	0	0	0	0
	Bit	7	6	5	4	3	2	1	0
		ARG1[7:0]							
Access		R/W	R/W	R/W	R/W	R/W	R/W	R/W	R/W
Reset		0	0	0	0	0	0	0	0

#### Bits 31:0 – ARG1[31:0] Argument 1

This register contains the SD command argument which is specified as the bit 39-8 of Command-Format in the “Physical Layer Simplified Specification V3.01” or “Embedded MultiMedia Card (e.MMC) Electrical Standard 4.51”.

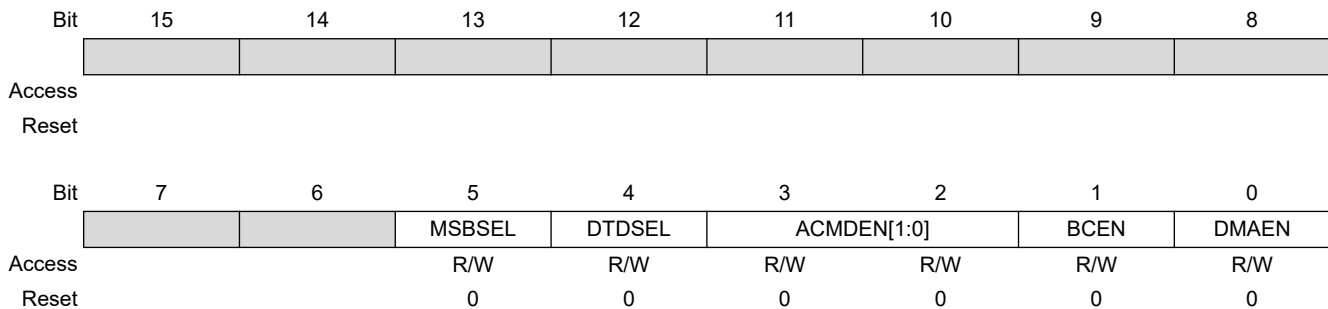
### 40.8.5 Transfer Mode Register

**Name:** TMR  
**Offset:** 0x0C  
**Reset:** 0x0000  
**Property:** -

This register is used to control data transfers. The user shall set this register before issuing a command which transfers data (refer to bit DPSEL in CR), or before issuing a Resume command. The user must save the value of this register when the data transfer is suspended (as a result of a Suspend command) and restore it before issuing a Resume command. To prevent data loss, this register cannot be written while data transactions are in progress. Writes to this register are ignored when bit PSR.CMDINH is '1'.

**Table 40-1. Determining the Transfer Type**

MSBSEL	BCEN	BCR.BLKCNT	Function
0	Don't care	Don't care	Single Transfer
1	0	Don't care	Infinite Transfer
1	1	Not Zero	Multiple Transfer
1	1	Zero	Stop Multiple Transfer



**Bit 5 – MSBSEL** Multi/Single Block Selection

Write this bit to '1' when issuing multiple-block transfer commands using DAT line(s). For any other commands, write this bit to 0. If this bit is 0, it is not necessary to write BCR to '1' (refer to [Table 1-4](#)).

**Bit 4 – DTDSEL** Data Transfer Direction Selection

This bit defines the direction of the DAT lines data transfers. Write this bit to '1' to transfer data from the device (SD Card/SDIO/e.MMC) to the peripheral. Write this bit to '0' for all other commands.

Value	Name	Description
0	WRITE	Writes data from the peripheral to the device.
1	READ	Reads data from the device to the peripheral.

**Bits 3:2 – ACMDEN[1:0]** Auto Command Enable

Two methods can be used to stop Multiple-block read and write operation:

1. Auto CMD12: when the ACMDEN field is set to 1, the peripheral issues CMD12 automatically when the last block transfer is completed. An Auto CMD12 error is indicated to ACESR. Auto CMD12 is not enabled if the command does not require CMD12.

- Auto CMD23: when the ACMDEN field is set to 2, the peripheral issues a CMD23 automatically before issuing a command specified in CR.

The following conditions are required to use Auto CMD23:

- A memory card that supports CMD23 (SCR[33] = 1)
- If DMA is used, it must be ADMA (SDMA not supported).
- Only CMD18 or CMD25 is issued.

**Note:** The peripheral does not check the command index.

Auto CMD23 can be used with or without ADMA. By writing CR, the peripheral issues a CMD23 first and then issues a command specified by the CR.CMDIDX field. If CMD23 response errors are detected, the second command is not issued. A CMD23 error is indicated in ACESR. The CMD23 argument (32-bit block count value) is defined in SSAR.

This field determines the use of auto command functions.

Value	Name	Description
0	DISABLED	Auto Command Disabled
1	CMD12	Auto CMD12 Enabled
2	CMD23	Auto CMD23 Enabled
3	Reserved	Reserved

### Bit 1 – BCEN Block Count Enable

This bit is used to enable BCR, which is only relevant for multiple block transfers. When this bit is 0, BCR is disabled, which is useful when executing an infinite transfer (refer to [Table 1-4](#)). If an ADMA2 transfer is more than 65535 blocks, this bit is set to 0 and the data transfer length is designated by the Descriptor Table.

Value	Name	Description
0	DISABLED	Block count is disabled
1	ENABLED	Block count is enabled

### Bit 0 – DMAEN DMA Enable

This bit enables the DMA functionality described in section “Supporting DMA” in “SD Host Controller Simplified Specification V3.00”. DMA can be enabled only if it is supported as indicated by the bit CA0R.ADMA2SUP. One of the DMA modes can be selected using the field HC1R.DMASEL. If DMA is not supported, this bit is meaningless and then always reads 0. When this bit is set to 1, a DMA operation begins when the user writes to the upper byte of CR.

Value	Name	Description
0	DISABLED	DMA functionality is disabled
1	ENABLED	DMA functionality is enabled

### 40.8.6 Command Register

**Name:** CR  
**Offset:** 0x0E  
**Reset:** 0x0000  
**Property:** -

	Bit	15	14	13	12	11	10	9	8
		CMDIDX[5:0]							
Access				R/W	R/W	R/W	R/W	R/W	R/W
Reset				0	0	0	0	0	0
	Bit	7	6	5	4	3	2	1	0
		CMDTYP[1:0]		DPSEL	CMDICEN	CMDCCEN		RESPTYP[1:0]	
Access		R/W	R/W	R/W		R/W		R/W	R/W
Reset		0	0	0	0	0		0	0

#### Bits 13:8 – CMDIDX[5:0] Command Index

This bit shall be set to the command number (CMD0-63, ACMD0-63) that is specified in bits 45-40 of the Command-Format in the “Physical Layer Simplified Specification V3.01”, “SDIO Simplified Specification V3.00”, and “Embedded MultiMedia Card (e.MMC) Electrical Standard 4.51”.

#### Bits 7:6 – CMDTYP[1:0] Command Type

Value	Name	Description
0	NORMAL	Other commands
1	SUSPEND	CMD52 to write “Bus Suspend” in the Card Common Control Registers (CCCR) (for SDIO only)
2	RESUME	CMD52 to write “Function Select” in the Card Common Control Registers (CCCR) (for SDIO only)
3	ABORT	CMD12, CMD52 to write “I/O Abort” in the Card Common Control Registers (CCCR) (for SDIO only)

#### Bit 5 – DPSEL Data Present Select

This bit is set to 1 to indicate that data is present and shall be transferred using the DAT lines. It is set to 0 for the following:

1. Commands using only CMD line (Ex. CMD52)
2. Commands with no data transfer but using Busy signal on DAT[0] line (Ex. CMD38)
3. Resume command

Value	Description
0	No data present
1	Data present

#### Bit 4 – CMDICEN Command Index Check Enable

If this bit is set to 1, the peripheral checks the Index field in the response to see if it has the same value as the command index. If it has not, it is reported as a Command Index Error (CMDIDX) in EISTR. If this bit is set to 0, the Index field of the response is not checked.

Value	Name	Description
0	DISABLED	The Command Index Check is disabled.

# SAM D5x/E5x Family Data Sheet

## SD/MMC Host Controller ...

Value	Name	Description
1	ENABLED	The Command Index Check is enabled.

### Bit 3 – CMDCCEN Command CRC Check Enable

If this bit is set to 1, the peripheral checks the CRC field in the response. If an error is detected, it is reported as a Command CRC Error (CMDCRC) in EISTR. If this bit is set to 0, the CRC field is not checked. The position of the CRC field is determined according to the length of the response.

Value	Name	Description
0	DISABLED	The Command CRC Check is disabled.
1	ENABLED	The Command CRC Check is enabled.

### Bits 1:0 – RESPTYP[1:0] Response Type

This field is set according to the response type expected for the command index (CMDIDX).

Value	Name	Description
0	NORESP	No Response
1	RL136	Response Length 136
2	RL48	Response Length 48
3	RL48BUSY	Response Length 48 with Busy

# SAM D5x/E5x Family Data Sheet

## SD/MMC Host Controller ...

### 40.8.7 Response Register n

**Name:** RR  
**Offset:** 0x10 + n\*0x04 [n=0..3]  
**Reset:** 0x00000000  
**Property:** -

	Bit	31	30	29	28	27	26	25	24
		CMDRESP[31:24]							
Access		R	R	R	R	R	R	R	R
Reset		0	0	0	0	0	0	0	0
	Bit	23	22	21	20	19	18	17	16
		CMDRESP[23:16]							
Access		R	R	R	R	R	R	R	R
Reset		0	0	0	0	0	0	0	0
	Bit	15	14	13	12	11	10	9	8
		CMDRESP[15:8]							
Access		R	R	R	R	R	R	R	R
Reset		0	0	0	0	0	0	0	0
	Bit	7	6	5	4	3	2	1	0
		CMDRESP[7:0]							
Access		R	R	R	R	R	R	R	R
Reset		0	0	0	0	0	0	0	0

#### Bits 31:0 – CMDRESP[31:0] Command Response

The table below describes the mapping of command responses from the SD/SDIO/e.MMC bus to these registers for each responses type. In this table, R[] refers to a bit range of the response data as transmitted on the SD/SDIO/e.MMC bus.

Type of response	Meaning of response	Response field	Response register
R1, R1b (normal response)	Card Status	R[39:8]	RR0[31:0]
R1b (Auto CMD12 response)	Card Status for Auto CMD12	R[39:8]	RR3[31:0]
R1 (Auto CMD23 response)	Card Status for Auto CMD23	R[39:8]	RR3[31:0]
R2 (CID, CSD register)	CID or CSD register	R[127:8]	RR0[31:0] RR1[31:0] RR2[31:0] RR3[23:0]
R3 (OCR register)	OCR register for memory	R[39:8]	RR0[31:0]
R4 (OCR register)	OCR register for I/O	R[39:8]	RR0[31:0]
R5, R5b	SDIO response	R[39:8]	RR0[31:0]

# SAM D5x/E5x Family Data Sheet

SD/MMC Host Controller ...

.....continued

Type of response	Meaning of response	Response field	Response register
R6 (Published RCA response)	New published RCA[31:16] and Card status bits	R[39:8]	RR0[31:0]



### 40.8.8 Buffer Data Port Register

**Name:** BDPR  
**Offset:** 0x20  
**Reset:** 0x00000000  
**Property:** -

	Bit	31	30	29	28	27	26	25	24
		BUFDATA[31:24]							
Access		R/W	R/W	R/W	R/W	R/W	R/W	R/W	R/W
Reset		0	0	0	0	0	0	0	0
	Bit	23	22	21	20	19	18	17	16
		BUFDATA[23:16]							
Access		R/W	R/W	R/W	R/W	R/W	R/W	R/W	R/W
Reset		0	0	0	0	0	0	0	0
	Bit	15	14	13	12	11	10	9	8
		BUFDATA[15:8]							
Access		R/W	R/W	R/W	R/W	R/W	R/W	R/W	R/W
Reset		0	0	0	0	0	0	0	0
	Bit	7	6	5	4	3	2	1	0
		BUFDATA[7:0]							
Access		R/W	R/W	R/W	R/W	R/W	R/W	R/W	R/W
Reset		0	0	0	0	0	0	0	0

**Bits 31:0 – BUFDATA[31:0] Buffer Data**

The peripheral's data buffer can be accessed through this 32-bit Data Port register.

# SAM D5x/E5x Family Data Sheet

## SD/MMC Host Controller ...

### 40.8.9 Present State Register

**Name:** PSR  
**Offset:** 0x24  
**Reset:** 0x00F80000  
**Property:** -

	Bit	31	30	29	28	27	26	25	24	
									CMDLL	
Access									R	
Reset									0	
	Bit	23	22	21	20	19	18	17	16	
		DATLL[3:0]				WRPPL	CARDDDL	CARDSS	CARDINS	
Access		R	R	R	R	R	R	R	R	
Reset		1	1	1	1	1	0	0	0	
	Bit	15	14	13	12	11	10	9	8	
						BUFRDEN	BUFWREN	RTACT	WTACT	
Access						R	R	R	R	
Reset						0	0	0	0	
	Bit	7	6	5	4	3	2	1	0	
						RTREQ	DLACT	CMDINHDL	CMDINHC	
Access						R	R	R	R	
Reset						0	0	0	0	

**Bit 24 – CMDLL** CMD Line Level

This status is used to check the CMD line level to recover from errors, and for debugging.

**Bits 23:20 – DATLL[3:0]** DAT[3:0] Line Level

This status is used to check the DAT line level to recover from errors, and for debugging. This is especially useful in detecting the Busy signal level from DAT[0].

**Bit 19 – WRPPL** Write Protect Pin Level

The Write Protect Switch is supported for memory and combo cards. This bit reflects the WP pin.

Value	Description
0	Write protected (WP = 0)
1	Write enabled (WP = 1)

**Bit 18 – CARDDDL** Card Detect Pin Level

This bit reflects the inverse value of the CD pin. Debouncing is not performed on this bit. This bit may be valid when CARDSS is set to 1, but it is not guaranteed because of the propagation delay. Use of this bit is limited to testing since it must be debounced by software.

Value	Description
0	No card present (CD = 1)
1	Card present (CD = 0)

### Bit 17 – CARDSS Card State Stable

This bit is used for testing. If it is 0, the CARDDPL is not stable. If this bit is set to 1, it means that the CARDDPL is stable. No Card state can be detected if this bit is set to 1 and CARDINS is set to 0. The Software Reset For All (SWRSTALL) in SRR does not affect this bit.

Value	Description
0	Reset or debouncing
1	No card or card inserted

### Bit 16 – CARDINS Card Inserted

This bit indicates whether a card has been inserted. The peripheral debounces this signal so that the user does not need to wait for it to stabilize.

A change from 0 to 1 rises the Card Insertion (CINS) status flag in NISTR if NISTER.CINS is set to 1. An interrupt is generated if NISIER.CINS is set to 1.

A change from 1 to 0 rises the Card Removal (CREM) status flag in NISTR if NISTER.CREM is set to 1. An interrupt is generated if NISIER.CREM is set to 1.

The Software Reset For All (SWRSTALL) in SRR does not affect this bit.

### Bit 11 – BUFRDEN Buffer Read Enable

This bit is used for non-DMA read transfers. This flag indicates that valid data exists in the peripheral data buffer. If this bit is 1, readable data exists in the buffer.

A change from 1 to 0 occurs when all the block data is read from the buffer.

A change from 0 to 1 occurs when block data is ready in the buffer. This rises the Buffer Read Ready (BRDRDY) status flag in NISTR if NISTER.BRDRDY is set to 1. An interrupt is generated if NISIER.BRDRDY is set to 1.

### Bit 10 – BUFWREN Buffer Write Enable

This bit is used for non-DMA write transfers. This flag indicates if space is available for write data. If this bit is 1, data can be written to the buffer.

A change from 1 to 0 occurs when all the block data are written to the buffer.

A change from 0 to 1 occurs when top of block data can be written to the buffer. This rises the Buffer Write Ready (BRWRDY) status flag in NISTR if NISTER.BRWRDY is set to 1. An interrupt is generated if NISIER.BRWRDY is set to 1.

### Bit 9 – RTACT Read Transfer Active

This bit is used to detect completion of a read transfer. Refer to section “Read Transaction Wait / Continue Timing” in the “SD Host Controller Simplified Specification V3.00” for more details on the sequence of events.

This bit is set to 1 in either of the following conditions:

- After the end bit of the read command.
- When a read operation is restarted by writing a 1 to BGCR.CONTR (Continue Request).

This bit is cleared to 0 in either of the following conditions:

- When the last data block as specified by Transfer Block Size (BLKSIZE) is transferred to the system.
- In case of ADMA2, end of read is designated by the descriptor table.
- When all valid data blocks in the peripheral have been transferred to the system and no current block transfers are being sent as a result of the Stop At Block Gap Request (STPBGR) of BGCR being set to 1.

A change from 1 to 0 rises the Transfer Complete (TRFC) status flag in NISTR if NISTER.TRFC is set to 1. An interrupt is generated if NISIER.TRFC is set to 1.

### Bit 8 – WTACT Write Transfer Active

This bit indicates a write transfer is active. If this bit is 0, it means no valid write data exists in the peripheral. Refer to section “Write Transaction Wait / Continue Timing” in the “SD Host Controller Simplified Specification V3.00” for more details on the sequence of events.

This bit is set to 1 in either of the following conditions:

- After the end bit of the write command.
- When a write operation is restarted by writing a 1 to BGCR.CONTR (Continue Request).

This bit is cleared to 0 in either of the following conditions:

- After getting the CRC status of the last data block as specified by the transfer count (single and multiple). In case of ADMA2, transfer count is designated by the descriptor table.
- After getting the CRC status of any block where a data transmission is about to be stopped by a Stop At Block Gap Request (STPBGR) of BGCR.

During a write transaction and as the result of the Stop At Block Gap Request (STPBGR) being set, a change from 1 to 0 rises the Block Gap Event (BLKGE) status flag in NISTR if NISTER.BLKGE is set to 1. An interrupt is generated if BLKGE is set to 1 in NISIER. This status is useful to determine whether non-DAT line commands can be issued during Write Busy.

### Bit 3 – RTREQ Retuning Request

The peripheral can instruct the software to execute a re-tuning sequence by setting this bit when the data window is shifted by a temperature drift and a tuned sampling point does not have a good margin to receive correct data.

This bit is cleared to 0 when a command is issued by setting Execute Tuning (EXTUN) in HC2R.

A change from 0 to 1 rises the Re-Tuning Event (RTEVT) status flag in NISTR if NISTER.RTEVT is set to 1. An interrupt is generated if NISIER.RTEVT is set to 1.

This bit is not set to 1 if Sampling Clock Select (SCLKSEL) in HC2R is set to 0 (using a fixed sampling clock). Refer to Re-Tuning Modes (RTMODE) in CA1R.

Value	Description
0	Fixed or well-tuned sampling clock
1	Sampling clock needs re-tuning

### Bit 2 – DLACT DAT Line Active

This bit indicates whether one of the DAT lines on the bus is in use.

In the case of read transactions:

This status indicates whether a read transfer is executing on the bus. A change from 1 to 0 resulting from setting the Stop At Block Gap Request (STPBGR) rises the Block Gap Event (BLKGE) status flag in NISTR if NISTER.BLKGE is set to 1. An interrupt is generated if NISIER.BLKGE is set to 1. Refer to section “Read Transaction Wait / Continue Timing” in the “SD Host Controller Simplified Specification V3.00” for details on timing.

This bit is set in either of the following cases:

- After the end bit of the read command.
- When writing 1 to BGCR.CONTR (Continue Request) to restart a read transfer.

This bit is peripheral cleared in either of the following cases:

- When the end bit of the last data block is sent from the bus to the peripheral. In case of ADMA2, the last block is designated by the last transfer of the Descriptor Table.
- When a read transfer is stopped at the block gap initiated by a Stop At Block Gap Request (STPBGR).

# SAM D5x/E5x Family Data Sheet

## SD/MMC Host Controller ...

The peripheral stops a read operation at the start of the interrupt cycle by driving the Read Wait (DAT[2] line) or by stopping the SD Clock. If the Read Wait signal is already driven (due to the fact that the data buffer cannot receive data), the peripheral can continue to stop the read operation by driving the Read Wait signal. It is necessary to support the Read Wait in order to use the Suspend/Resume operation.

In the case of write transactions:

This status indicates that a write transfer is executing on the bus. A change from 1 to 0 rises the Transfer Complete (TRFC) status flag in NISTR if NISTER.TRFC is set to 1. An interrupt is generated if NISIER.TRFC is set to 1. Refer to section “Write Transaction Wait / Continue Timing” in the “SD Host Controller Simplified Specification V3.00” for details on timing.

This bit is set in either of the following cases:

- After the end bit of the write command.
- When writing 1 to BGCR.CONTR (Continue Request) to continue a write transfer.

This bit is cleared in either of the following cases:

- When the card releases Write Busy of the last data block. If the card does not drive a Busy signal for 8 SDCLK, the peripheral considers the card drive “Not Busy”. In the case of ADMA2, the last block is designated by the last transfer of the Descriptor Table.
- When the card releases Write Busy prior to wait for write transfer as a result of a Stop At Block Gap Request (STPBGR).

Command with Busy:

This status indicates whether a command that indicates Busy (ex. erase command for memory) is executing on the bus. This bit is set to 1 after the end bit of the command with Busy and cleared when Busy is de-asserted. A change from 1 to 0 rises the Transfer Complete (TRFC) status flag in NISTR if NISTER.TRFC is set to 1. An interrupt is generated if NISIER.TRFC is set to 1. Refer to Figures 2.11 to 2.13 in the “SD Host Controller Simplified Specification V3.00”.

Value	Description
0	DAT Line Inactive
1	DAT Line Active

### Bit 1 – CMDINH D Command Inhibit (DAT)

This status bit is 1 if either the DAT Line Active (DLACT) or the Read Transfer Active (RTACT) is set to 1. If this bit is 0, it indicates that the peripheral can issue the next command. Commands with a Busy signal belong to Command Inhibit (DAT) (ex. R1b, R5b type). A change from 1 to 0 rises the Transfer Complete (TRFC) status flag in NISTR if NISTER.TRFC is set to 1. An interrupt is generated if NISIER.TRFC is set to 1.

Note: The software can save registers in the 000-00Dh range for a suspend transaction after this bit has changed from 1 to 0.

Value	Description
0	Can issue a command which uses the DAT line(s).
1	Cannot issue a command which uses the DAT line(s).

### Bit 0 – CMDINH C Command Inhibit (CMD)

If this bit is 0, it indicates the CMD line is not in use and the peripheral can issue a command using the CMD line. This bit is set to 1 immediately after CR is written. This bit is cleared when the command response is received. Auto CMD12 and Auto CMD23 consist of two responses. In this case, this bit is not cleared by the CMD12 or CMD23 response, but by the Read/Write command response.

Status issuing Auto CMD12 is not read from this bit. So, if a command is issued during Auto CMD12 operation, the peripheral manages to issue both commands: CMD12 and a command set by CR.

# SAM D5x/E5x Family Data Sheet

## SD/MMC Host Controller ...

Even if the Command Inhibit (DAT) is set to 1, commands using only the CMD line can be issued if this bit is 0.

A change from 1 to 0 rises the Command Complete (CMDC) status flag in NISTR if NISTER.CMDC is set to 1. An interrupt is generated if NISIER.CMDC is set to 1.

If the peripheral cannot issue the command because of a command conflict error (refer to CMDCRC in EISTR) or because of a 'Command Not Issued By Auto CMD12' error (refer to [Section 1.2.31 "SDMMC Auto CMD Error Status Register"](#)), this bit remains 1 and Command Complete is not set.

Value	Description
0	Can issue a command using only CMD line.
1	Cannot issue a command.

### 40.8.10 Host Control 1 Register

**Name:** HC1R  
**Offset:** 0x28  
**Reset:** 0x00  
**Property:** -

	7	6	5	4	3	2	1	0
	CARDDSEL	CARDDTL		DMASEL[1:0]		HSEN	DW	LEDCTRL
Access	R/W	R/W				R/W	R/W	R/W
Reset	0	0		0	0	0	0	0

#### Bit 7 – CARDDSEL Card Detect Signal Selection

**Note:**

This register entry is specific to the SD/SDIO operation mode.

This bit selects the source for the card detection.

Value	Description
0	The CD pin is selected.
1	The Card Detect Test Level (CARDDTL) is selected (for test purpose).

#### Bit 6 – CARDDTL Card Detect Test Level

**Note:**

This register entry is specific to the SD/SDIO operation mode.

This bit is enabled while the Card Detect Signal Selection (CARDDSEL) is set to 1 and it indicates whether the card is inserted or not.

Value	Description
0	No card.
1	Card inserted.

#### Bits 4:3 – DMASEL[1:0] DMA Select

One of the supported DAM modes can be selected. The user must check support of DMA modes by referring the CA0R. Use of selected DMA is determined by DMA Enable (DMAEN) in TMR.

Value	Name	Description
0	SDMA	SDMA is selected
1	Reserved	Reserved
2	ADMA32	32-bit Address ADMA2 is selected
3	Reserved	Reserved

#### Bit 2 – HSEN High Speed Enable

Before setting this bit, the user must check the High Speed Support (HSSUP) in CA0R.

If this bit is set to 0 (default), the peripheral outputs CMD line and DAT lines at the falling edge of the SD clock (up to 25 MHz). If this bit is set to 1, the SDMMC outputs the CMD line and the DAT lines at the rising edge of the SD clock (up to 50 MHz).

If Preset Value Enable (PVALEN) in HC2R is set to 1, the user needs to reset SD Clock Enable (SDCLKEN) before changing this bit to avoid generating clock glitches. After setting this bit to 1, the user sets SDCLEN to 1 again.

Value	Description
0	Normal Speed mode.

Value	Description
1	High Speed mode. Note: 1. This bit is effective only if MC1R.DDR is set to 0. 2. The clock divider (DIV) in CCR must be set to a value different from 0 when HSEN is 1.

### Bit 1 – DW Data Width

This bit selects the data width of the peripheral. It must be set to match the data width of the card.

**Note:** If the Extended Data Transfer Width is 1, this bit has no effect and the data width is 8-bit mode.

Value	Name	Description
0	1_BIT	1-bit mode
1	4_BIT	4-bit mode

### Bit 0 – LEDCTRL LED Control

**Note:**

This register entry is specific to the SD/SDIO operation mode.

This bit is used to caution the user not to remove the card while it is being accessed. If the software is going to issue multiple commands, this bit is set to 1 during all transactions.

Value	Name	Description
0	OFF	LED off
1	ON	LED on



### 40.8.11 Power Control Register

**Name:** PCR  
**Offset:** 0x29  
**Reset:** 0x0E  
**Property:** -

	7	6	5	4	3	2	1	0
					SDBVSEL[2:0]			SDBPWR
Access					R/W	R/W	R/W	R/W
Reset					1	1	1	0

#### Bits 3:1 – SDBVSEL[2:0] SD Bus Voltage Select

By setting this bit, the user selects the voltage level for the card. Before setting this register, the user must check the Voltage Support in CA0R. If an unsupported voltage is selected, the system does not supply the bus voltage.

Value	Name	Description
0x0–0x4	Reserved	Reserved
0x5	1V8	1.8 Volt (Typical)
0x6	3V0	3.0 Volt (Typical)
0x7	3V3	3.3 Volt (Typical)

#### Bit 0 – SDBPWR SD Bus Power

This bit is automatically cleared by the peripheral if the card is removed. If this bit is cleared, the peripheral stops driving CMD and DAT[7:0] (tri-state) and drives CK to low level.

### 40.8.12 Block Gap Control Register

**Name:** BGCR  
**Offset:** 0x2A  
**Reset:** 0x00  
**Property:** -

	7	6	5	4	3	2	1	0
					INTBG	RWCTRL	CONTR	STPBGR
Access					R/W	R/W	R/W	R/W
Reset					0	0	0	0

#### Bit 3 – INTBG Interrupt at Block Gap

**Note:**

This register entry is specific to the SD/SDIO operation mode.

This bit is valid only in 4-bit mode of the SDIO card and selects a sample point in the interrupt cycle. Setting to 1 enables interrupt detection at the block gap for a multiple block transfer. If the SDIO card cannot signal an interrupt during a multiple block transfer, this bit should be set to 0. When the software detects an SDIO card insertion, it sets this bit according to the CCCR of the SDIO card.

Value	Name	Description
0	DISABLED	Interrupt detection disabled
1	ENABLED	Interrupt detection enabled

#### Bit 2 – RWCTRL Read Wait Control

**Note:**

This register entry is specific to the SD/SDIO operation mode.

The Read Wait control is optional for SDIO cards. If the card supports Read Wait, set this bit to enable use of the Read Wait protocol to stop read data using the DAT[2] line. Otherwise, the peripheral stops the SDCLK to hold read data, which restricts command generation. When the software detects an SD card insertion, this bit must be set according to the CCCR of the SDIO card. If the card does not support Read Wait, this bit shall never be set to 1, otherwise an DAT line conflict may occur. If this bit is set to 0, Suspend/Resume cannot be supported.

Value	Description
0	Disables Read Wait control.
1	Enables Read Wait control.

#### Bit 1 – CONTR Continue Request

This bit is used to restart a transaction which was stopped using a Stop At Block Gap Request (STPBGR). To cancel stop at the block gap, set STPBGR to 0 and set this bit to 1 to restart the transfer. The peripheral automatically clears this bit in either of the following cases:

- In the case of a read transaction, the DAT Line Active (DLACT) changes from 0 to 1 as a read transaction restarts.
- In the case of a write transaction, the Write Transfer Active (WTACT) changes from 0 to 1 as the write transaction restarts.

Therefore, it is not necessary to set this bit to 0. If STPBGR is set to 1, any write to this bit is ignored. Refer to the “Abort Transaction” and “Suspend/Resume” sections in the “SD Host Controller Simplified Specification V3.00” for more details.

Value	Description
0	No affect
1	Restart

**Bit 0 – STPBGR** Stop At Block Gap Request

This bit is used to stop executing read and write transactions at the next block gap for non-DMA, SDMA, and ADMA transfers. The user must leave this bit set to 1 until Transfer Complete (TRFC) in NISTR. Clearing both Stop At Block Gap Request and Continue Request does not cause the transaction to restart. This bit can be set whether the card supports the Read Wait signal or not.

During read transfers, the peripheral stops the transaction by using the Read Wait signal (DAT[2]) if supported, or by stopping the SD clock otherwise.

In case of write transfers in which the user writes data to BDPR, this bit must be set to 1 after all the block of data is written. If this bit is set to 1, the user does not write data to BDPR.

This bit affects Read Transfer Active (RTACT), Write Transfer Active (WTACT), DAT Line Active (DLACT) and Command Inhibit (DAT) (CMDINH) in PSR.

Refer to the “Abort Transaction” and “Suspend/Resume” sections in the “SD Host Controller Simplified Specification V3.00” for more details.

Value	Description
0	Transfer
1	Stop

### 40.8.13 Wakeup Control Register: SD/SDIO

**Name:** WCR  
**Offset:** 0x2B  
**Reset:** 0x00  
**Property:** -

	7	6	5	4	3	2	1	0
						WKENCREM	WKENCINS	WKENCINT
Access						R/W	R/W	R/W
Reset						0	0	0

**Bit 2 – WKENCREM** Wake-up Event Enable on Card Removal

This bit enables a wake-up event via Card Removal (CREM) in NISTR. FN\_WUS (Wake-Up Support) in the CIS (Card Information Structure) does not affect this bit.

Value	Name	Description
0	DISABLED	Wake-Up Event disabled
1	ENABLED	Wake-Up Event enabled

**Bit 1 – WKENCINS** Wake-Up Event Enable on Card Insertion

This bit enables a wake-up event via Card Insertion (CINS) in NISTR. FN\_WUS (Wake-Up Support) in the CIS (Card Information Structure) does not affect this bit.

Value	Name	Description
0	DISABLED	Wake-Up Event disabled
1	ENABLED	Wake-Up Event enabled

**Bit 0 – WKENCINT** Wake-Up Event Enable on Card Interrupt

This bit enables a wake-up event via Card Interrupt (CINT) in NISTR. This bit can be set to 1 if FN\_WUS (Wake-Up Support) in the CIS (Card Information Structure) is set to 1 in the SDIO card.

Value	Name	Description
0	DISABLED	Wake-Up Event disabled
1	ENABLED	Wake-Up Event enabled

### 40.8.14 Clock Control Register

**Name:** CCR  
**Offset:** 0x2C  
**Reset:** 0x0000  
**Property:** -

	Bit	15	14	13	12	11	10	9	8
		SDCLKFSEL[7:0]							
Access		R/W	R/W	R/W	R/W	R/W	R/W	R/W	R/W
Reset		0	0	0	0	0	0	0	0
	Bit	7	6	5	4	3	2	1	0
		USDCLKFSEL[1:0]		CLKGSEL			SDCLKEN	INTCLKS	INTCLKEN
Access		R/W	R/W	R/W			R/W	R/W	R/W
Reset		0	0	0			0	0	0

#### Bits 15:8 – SDCLKFSEL[7:0] SDCLK Frequency Select

This register is used to select the frequency of the SDCLK pin. There are two SDCLK Frequency modes according to Clock Generator Select (CLKGSEL).

The length of the clock divider (DIV) is extended to 10 bits (DIV[9:8] = USDCLKFSEL, DIV[7:0] = SDCLKFSEL)

– 10-bit Divided Clock Mode (CLKGSEL = 0):

$$F_{SDCLK} = F_{BASECLK} / (2 \times DIV)$$

. If DIV = 0 then

$$F_{SDCLK} = F_{BASECLK}$$

– Programmable Clock Mode (CLKGSEL = 1):

$$F_{SDCLK} = F_{MULTCLK} / (DIV + 1)$$

This field depends on the setting of Preset Value Enable (PVALEN) in HC2R.

If HC2R.PVALEN = 0, this field is set by the user.

If HC2R.PVALEN = 1, this field is automatically set to a value specified in one of the PVR.

#### Bits 7:6 – USDCLKFSEL[1:0] Upper Bits of SDCLK Frequency Select

These bits expand the SDCLK Frequency Select (SDCLKFSEL) to 10 bits. These two bits are assigned to bit 09-08 of the clock divider as described in SDCLKFSEL.

#### Bit 5 – CLKGSEL Clock Generator Select

This bit is used to select the clock generator mode in the SDCLK Frequency Select field. If the Programmable mode is not supported (CA1R.CLKMULT (Clock Multiplier) set to 0), then this bit cannot be written and is always read at 0.

This bit depends on the setting of Preset Value Enable (PVALEN) in HC2R.

If HC2R.PVALEN = 0, this bit is set by the user.

If HC2R.PVALEN = 1, this bit is automatically set to a value specified in one of the PVRx.

Value	Description
0	Divided Clock mode (BASECLK is used to generate SDCLK).
1	Programmable Clock mode (MULTCLK is used to generate SDCLK).

### Bit 2 – SDCLKEN SD Clock Enable

The peripheral stops the SD Clock when writing this bit to 0. SDCLK Frequency Select (SDCLKFSEL) can be changed when this bit is 0. Then, the peripheral maintains the same clock frequency until SDCLK is stopped (Stop at SDCLK=0). If Card Inserted (CARDINS) in PSR is cleared, this bit is also cleared.

Value	Description
0	SD Clock disabled
1	SD Clock enabled

### Bit 1 – INTCLKS Internal Clock Stable

This bit is set to 1 when the SD clock is stable after setting CCR.INTCLKEN (Internal Clock Enable) to 1. The user must wait to set SD Clock Enable (SDCLKEN) until this bit is set to 1.

Value	Description
0	Internal clock not ready
1	Internal clock ready

### Bit 0 – INTCLKEN Internal Clock Enable

This bit is set to 0 when the peripheral is not used or is awaiting a wakeup interrupt. In this case, its internal clock is stopped to reach a very low power state. Registers are still able to be read and written. The clock starts to oscillate when this bit is set to 1. Once the clock oscillation is stable, the peripheral sets Internal Clock Stable (INTCLKS) in this register to 1.

This bit does not affect card detection.

Value	Description
0	The internal clock stops.
1	The internal clock oscillates.

### 40.8.15 Timeout Control Register

**Name:** TCR  
**Offset:** 0x2E  
**Reset:** 0x00  
**Property:** -

Bit	7	6	5	4	3	2	1	0
					DTCVAL[3:0]			
Access					R/W	R/W	R/W	R/W
Reset					0	0	0	0

**Bits 3:0 – DTCVAL[3:0]** Data Timeout Counter Value

This value determines the interval at which DAT line timeouts are detected. For more information about timeout generation, refer to Data Timeout Error (DATTEO) in EISTR. When setting this register, the user can prevent inadvertent timeout events by clearing the Data Timeout Error Status Enable (in EISTER).

$$\text{TIMEOUT}_{(\mu\text{s})} = \frac{2^{13 + \text{DTCVAL}}}{F_{\text{BASECLK(MHz)}}}$$

Note: DTCVAL = F<sub>(Hexa)</sub> is reserved.

### 40.8.16 Software Reset Register

**Name:** SRR  
**Offset:** 0x2F  
**Reset:** 0x00  
**Property:** -

	7	6	5	4	3	2	1	0
						SWRSTDAT	SWRSTCMD	SWRSTALL
Access						R/W	R/W	R/W
Reset						0	0	0

**Bit 2 – SWRSTDAT** Software reset for DAT line

Only part of a data circuit is reset. The DMA circuit is also reset.

The following registers and bits are cleared by this bit:

- Buffer Data Port Register [40.8.8 BDPR](#): BUFDATA is cleared and initialized.
- Present State Register [40.8.9 PSR](#):
  - Buffer Read Enable (BUFRDEN)
  - Buffer Write Enable (BUFWREN)
  - Read Transfer Active (RTACT)
  - Write Transfer Active (WTACT)
  - DAT Line Active (DATLL)
  - Command Inhibit - DAT (CMDINH)
- Block Gap Control Register [40.8.12 BGCR](#):
  - Continue Request (CONTR)
  - Stop At Block Gap Request (STPBGR)
- Normal Interrupt Status Register [40.8.17 NISTR](#):
  - Buffer Read Ready (BRDRDY)
  - Buffer Write Ready (BWRRDY)
  - DMA Interrupt (DMAINT)
  - Block Gap Event (BLKGE)
  - Transfer Complete (TRFC)

Value	Description
0	Work
1	Reset

**Bit 1 – SWRSTCMD** Software reset for CMD line

Only part of a command circuit is reset.

The following registers and bits are cleared by this bit:

- Present State Register [40.8.9 PSR](#):
  - Command Inhibit (CMD) (CMDINH)
- Normal Interrupt Status Register [40.8.17 NISTR](#):
  - Command Complete (CMDC)



Value	Description
0	Work
1	Reset

**Bit 0 – SWRSTALL** Software reset for All

This reset affects the entire peripheral except the card detection circuit. During initialization, the peripheral must be reset by setting this bit to 1. This bit is automatically cleared to 0 when CA0R and CA1R are valid and the user can read them. If this bit is set to 1, the user should issue a reset command and reinitialize the card.

List of registers cleared to 0:

- SDMA System Address / Argument 2 Register [40.8.1 SSAR](#)
- Block Size Register [40.8.2 BSR](#)
- Block Count Register [40.8.3 BCR](#)
- Argument 1 Register [40.8.4 ARG1R](#)
- Transfer Mode Register [40.8.5 TMR](#)
- Command Register [40.8.6 CR](#)
- Response Register n [40.8.7 RR](#)
- Buffer Data Port Register [40.8.8 BDPR](#)
- Present State Register [40.8.9 PSR](#) (except CMDLL, DATLL, WRPPL, CARDDDL, CARDSS, CARDINS)
- Host Control 1 Register [40.8.10 HC1R](#)
- Power Control Register [40.8.11 PCR](#)
- Block Gap Control Register [40.8.12 BGCR](#)
- Wakeup Control Register [40.8.13 WCR](#)
- Clock Control Register [40.8.14 CCR](#)
- Timeout Control Register [40.8.15 TCR](#)
- Normal Interrupt Status Register [40.8.17 NISTR](#)
- Error Interrupt Status Register [40.8.18 EISTR](#)
- Normal Interrupt Status Enable Register [40.8.19 NISTER](#)
- Error Interrupt Status Enable Register [40.8.20 EISTER](#)
- Normal Interrupt Signal Enable Register [40.8.21 NISIER](#)
- Error Interrupt Signal Enable Register [40.8.22 EISIER](#)
- Auto CMD Error Status Register [40.8.23 ACESR](#)
- Host Control 2 Register [40.8.25 HC2R - DEFAULT](#)
- ADMA Error Status Register [40.8.31 AESR](#)
- ADMA System Address Registers [40.8.32 ASAR](#)
- Slot Interrupt Status Register [40.8.34 SISR](#)
- e.MMC Control 1 Register [40.8.37 MC1R](#)
- e.MMC Control 2 Register [40.8.38 MC2R](#)
- AHB Control Register [40.8.39 ACR](#)
- Clock Control 2 Register [40.8.40 CC2R](#)
- Capabilities Control Register [40.8.41 CACR](#) (except KEY)

Value	Description
0	Work

# SAM D5x/E5x Family Data Sheet

SD/MMC Host Controller ...

---

---

Value	Description
1	Reset

### 40.8.17 Normal Interrupt Status Register

**Name:** NISTR  
**Offset:** 0x30  
**Reset:** 0x0000  
**Property:** -

	15	14	13	12	11	10	9	8
	ERRINT	BOOTAR						CINT
Access	R/W	R/W						R/W
Reset	0	0						0
	7	6	5	4	3	2	1	0
	CREM	CINS	BRDRDY	BWRRDY	DMAINT	BLKGE	TRFC	CMDC
Access	R/W	R/W	R/W	R/W	R/W	R/W	R/W	R/W
Reset	0	0	0	0	0	0	0	0

#### Bit 15 – ERRINT Error Interrupt

If any of the bits in EISTR are set, then this bit is set. Therefore, the user can efficiently test for an error by checking this bit first. This bit is read-only.

Value	Description
0	No error
1	Error

#### Bit 14 – BOOTAR Boot Acknowledge Received

**Note:** This register entry is specific to the e.MMC operation mode.

This bit is set to 1 when the peripheral received a Boot Acknowledge pattern from the e.MMC. This bit can only be set to 1 if NISTER.BOOTAR is set to 1. An interrupt can only be generated if NISIER.BOOTAR is set to 1.

Writing this bit to 1 clears this bit.

Value	Description
0	Boot Acknowledge pattern not received.
1	Boot Acknowledge pattern received.

#### Bit 8 – CINT Card Interrupt

**Note:**

This register entry is specific to the SD/SDIO operation mode.

Writing this bit to 1 does not clear this bit. It is cleared by resetting the SD card interrupt factor. In 1-bit mode, the peripheral detects the Card Interrupt without SDCLK to support wake-up. In 4-bit mode, the Card Interrupt signal is sampled during the interrupt cycle, so there are some sample delays between the interrupt signal from the SD card and the interrupt to the system.

When this bit has been set to 1 and the user needs to start this interrupt service, Card Interrupt Status Enable (CINT) in NISTER may be set to 0 in order to clear the card interrupt statuses latched in the peripheral and to stop driving the interrupt signal to the system. After completion of the card interrupt service (it should reset interrupt factors in the SD card and the interrupt signal may not be asserted), set NISTER.CINT to 1 and start sampling the interrupt signal again.

Interrupt detected by DAT[1] is supported when there is one card per slot. In case of a shared bus, interrupt pins are used to detect interrupts. If 0 is set to Interrupt Pin Select (INTPSEL) in SBCR, this

status is effective. If a non-zero value is set to INTPSEL, INT\_A, INT\_B or INT\_C is used as device interrupts.

This bit can only be set to 1 if NISTER.CREM is set to 1. An interrupt can only be generated if NISIER.CREM is set to 1.

Value	Description
0	No card interrupt
1	Card interrupt

### Bit 7 – CREM Card Removal

#### Note:

This register entry is specific to the SD/SDIO operation mode.

This status is set to 1 if Card Inserted (CARDINS) in PSR changes from 1 to 0. When the user writes this bit to 1 to clear this status, the status of PSR.CARDINS must be confirmed because the card detect state may possibly be changed when the user clears this bit and no interrupt event can be generated.

This bit can only be set to 1 if NISTER.CREM is set to 1. An interrupt can only be generated if NISIER.CREM is set to 1.

Writing this bit to 1 clears this bit.

Value	Description
0	Card state unstable or card inserted
1	Card removed

### Bit 6 – CINS Card Insertion

#### Note:

This register entry is specific to the SD/SDIO operation mode.

This status is set if Card Inserted (CARDINS) in PSR changes from 0 to 1. When the user writes this bit to 1 to clear this status, the status of PSR.CARDINS must be confirmed because the card detect state may possibly be changed when the user clears this bit and no interrupt event can be generated.

This bit can only be set to 1 if NISTER.CINS is set to 1. An interrupt can only be generated if NISIER.CINS is set to 1.

Writing this bit to 1 clears this bit.

Value	Description
0	Card state unstable or card removed
1	Card inserted

### Bit 5 – BRDRDY Buffer Read Ready

This status is set to 1 if the Buffer Read Enable (BUFRDEN) changes from 0 to 1. Refer to BUFRDEN in PSR.

This bit can only be set to 1 if NISTER.BRDRDY is set to 1. An interrupt can only be generated if NISIER.BRDRDY is set to 1.

Writing this bit to 1 clears this bit.

Value	Description
0	Not ready to read buffer
1	Ready to read buffer

### Bit 4 – BWRRDY Buffer Write Ready

This status is set to 1 if the Buffer Write Enable (BUFWREN) changes from 0 to 1. Refer to BUFWREN in PSR.

This bit can only be set to 1 if NISTER.BWRRDY is set to 1. An interrupt can only be generated if NISIER.BWRRDY is set to 1.

Writing this bit to 1 clears this bit.

Value	Description
0	Not ready to write buffer
1	Ready to write buffer

### Bit 3 – DMAINT DMA Interrupt

This status is set if the peripheral detects the Host SDMA Buffer boundary during transfer. Refer to SDMA Buffer Boundary (BOUNDARY) in BSR.

In case of ADMA, by setting the “int” field in the descriptor table, the peripheral rises this status flag when the descriptor line is completed. This status flag does not rise after Transfer Complete (TRFC).

This bit can only be set to 1 if NISTER.DMAINT is set to 1. An interrupt can only be generated if NISIER.DMAINT is set to 1.

Writing this bit to 1 clears this bit.

Value	Description
0	No DMA Interrupt
1	DMA Interrupt

### Bit 2 – BLKGE Block Gap Event

If the Stop At Block Gap Request (STPBGR) in BGCR is set to 1, this bit is set when either a read or a write transaction is stopped at a block gap. If STPBGR is not set to 1, this bit is not set to 1.

In the case of a Read transaction:

This bit is set at the falling edge of the DAT Line Active (DLACT) status (when the transaction is stopped at SD bus timing). The Read Wait must be supported in order to use this function. Refer to section “Read Transaction Wait / Continue Timing” in the “SD Host Controller Simplified Specification V3.00” about the detailed timing.

In the case of a Write transaction:

This bit is set at the falling edge of the Write Transfer Active (WTACT) status (after getting the CRC status at SD bus timing). Refer to section “Write Transaction Wait / Continue Timing” in the “SD Host Controller Simplified Specification V3.00” for more details on the sequence of events.

This bit can only be set to 1 if NISTER.BLKGE is set to 1. An interrupt can only be generated if NISIER.BLKGE is set to 1.

Writing this bit to 1 clears this bit.

Value	Description
0	No block gap event
1	Transaction stopped at block gap

### Bit 1 – TRFC Transfer Complete

This bit is set when a read/write transfer and a command with Busy is completed.

In the case of a Read Transaction:

This bit is set at the falling edge of the Read Transfer Active Status. The interrupt is generated in two cases. The first is when a data transfer is completed as specified by the data length (after the last data has been read to the system). The second is when data has stopped at the block gap and completed the data transfer by setting the Stop At Block Gap Request (STPBGR) in BGCR (after valid data has been read to the system). Refer to section “Read Transaction Wait / Continue Timing” in the “SD Host Controller Simplified Specification V3.00” for more details on the sequence of events.

In the case of a Write Transaction:

# SAM D5x/E5x Family Data Sheet

## SD/MMC Host Controller ...

This bit is set at the falling edge of the DAT Line Active (DLACT) status. This interrupt is generated in two cases. The first is when the last data is written to the card as specified by the data length and the Busy signal is released. The second is when data transfers are stopped at the block gap by setting Stop At Block Gap Request (STPBGR) in BGCR and data transfers are completed. (After valid data is written to the card and the Busy signal is released). Refer to section “Write Transaction Wait / Continue Timing” in the “SD Host Controller Simplified Specification V3.00” for more details on the sequence of events.

In the case of command with Busy:

This bit is set when Busy is de-asserted. Refer to DAT Line Active (DLACT) and Command Inhibit (DAT) (CMDINH) in PSR.

This bit can only be set to 1 if NISTER.TRFC is set to 1. An interrupt can only be generated if NISIER.TRFC is set to 1.

Writing this bit to 1 clears this bit.

The table below shows that Transfer Complete (TRFC) has a higher priority than Data Timeout Error (DATTEO). If both bits are set to 1, execution of a command can be considered to be completed.

TRFC	DATTEO	Meaning of the status
0	0	Interrupted by another factor
0	1	Timeout occurred during transfer
1	Don't Care	Command execution complete

Value	Description
0	Command execution is not complete.
1	Command execution is complete.

### Bit 0 – CMDC Command Complete

This bit is set when getting the end bit of the command response. Auto CMD12 and Auto CMD23 consist of two responses. Command Complete is not generated by the response of CMD12 or CMD23, but it is generated by the response of a read/write command. Refer to Command Inhibit (CMD) in PSR for details on how to control this bit.

This bit can only be set to 1 if NISTER.CMDC is set to 1. An interrupt can only be generated if NISIER.CMDC is set to 1.

Writing this bit to 1 clears this bit.

The table below shows that Command Timeout Error (CMDTEO) has a higher priority than Command Complete (CMDC). If both bits are set to 1, it can be considered that the response was not received correctly.

CMDC	CMDTEO	Meaning of the status
0	0	Interrupted by another factor
Don't care	1	Response not received within 64 SDCLK cycles
1	0	Response received

Value	Description
0	No command complete
1	Command complete

### 40.8.18 Error Interrupt Status Register

**Name:** EISTR  
**Offset:** 0x32  
**Reset:** 0x0000  
**Property:** -

	15	14	13	12	11	10	9	8
				BOOTAE			ADMA	ACMD
Access				R/W			R/W	R/W
Reset				0			0	0
	7	6	5	4	3	2	1	0
	CURLIM	DATEND	DATCRC	DATTEO	CMDIDX	CMDEND	CMDCRC	CMDTEO
Access	R/W	R/W	R/W	R/W	R/W	R/W	R/W	R/W
Reset	0	0	0	0	0	0	0	0

#### Bit 12 – BOOTAE Boot Acknowledge Error

**Note:** This register entry is specific to the e.MMC operation mode.

This bit is set to 1 when detecting that the e.MMC Boot Acknowledge Status has a value other than “010”. This bit can only be set to 1 if EISTER.BOOTAE is set to 1. An interrupt can only be generated if EISIER.BOOTAE is set to 1.

Writing this bit to 1 clears this bit.

Value	Description
0	No error
1	Error

#### Bit 9 – ADMA ADMA Error

This bit is set to 1 when the peripheral detects errors during an ADMA-based data transfer. The state of the ADMA at an error occurrence is saved in AESR.

In addition, the peripheral rises this status bit when it detects some invalid description data (Valid=0) at the ST\_FDS state (refer to section “Advanced DMA” in the “SD Host Controller Simplified Specification V3.00”. ADMA Error Status (ERRST) in AESR indicates that an error occurs in ST\_FDS state. The user may find that the Valid bit is not set at the error descriptor.

This bit can only be set to 1 if EISTER.ADMA is set to 1. An interrupt can only be generated if EISIER.ADMA is set to 1.

Writing this bit to 1 clears this bit.

Value	Description
0	No error
1	Error

#### Bit 8 – ACMD Auto CMD Error

Auto CMD12 and Auto CMD23 use this error status. This bit is set to 1 when detecting that one of the 0 to 4 bits in AESR (ACESR[4:0]) has changed from 0 to 1. In the case of Auto CMD12, this bit is set to 1, not only when errors occur in Auto CMD12, but also when Auto CMD12 is not executed due to the previous command error.

This bit can only be set to 1 if EISTER.ACMD is set to 1. An interrupt can only be generated if EISIER.ACMD is set to 1.

Writing this bit to 1 clears this bit.

Value	Description
0	No error
1	Error

### Bit 7 – CURLIM Current Limit Error

By setting SD Bus Power (SDBPWR) in PCR, the peripheral is requested to supply power for the SD Bus. The peripheral is protected from an illegal card by stopping power supply to the card, in which case this bit indicates a failure status. Reading 1 means the peripheral is not supplying power to the card due to some failure. Reading 0 means that the peripheral is supplying power and no error has occurred. The peripheral may require some sampling time to detect the current limit.

This bit can only be set to 1 if EISTER.CURLIM is set to 1. An interrupt can only be generated if EISIER.CURLIM is set to 1.

Writing this bit to 1 clears this bit.

Value	Description
0	No error
1	Error

### Bit 6 – DATEND Data End Bit Error

This bit is set to 1 either when detecting 0 at the end bit position of read data which uses the DAT line or at the end bit position of the CRC Status.

This bit can only be set to 1 if EISTER.DATEND is set to 1. An interrupt can only be generated if EISIER.DATEND is set to 1.

Writing this bit to 1 clears this bit.

Value	Description
0	No error
1	Error

### Bit 5 – DATCRC Data CRC Error

This bit is set to 1 when detecting a CRC error during a transfer of read data which uses the DAT line or when detecting that the Write CRC Status has a value other than '010'.

This bit can only be set to 1 if EISTER.DATCRC is set to 1. An interrupt can only be generated if EISIER.DATCRC is set to 1.

Writing this bit to 1 clears this bit.

Value	Description
0	No error
1	Error

### Bit 4 – DATTEO Data Timeout error

This bit is set to 1 when detecting one of following timeout conditions:

- Busy timeout for R1b, R5b response type (see “Physical Layer Simplified Specification V3.01” and “SDIO Simplified Specification V3.00” ).
- Busy timeout after Write CRC Status.
- Write CRC Status timeout.
- Read data timeout.

This bit can only be set to 1 if EISTER.DATTEO is set to 1. An interrupt can only be generated if EISIER.DATTEO is set to 1.

Writing this bit to 1 clears this bit.



Value	Description
0	No error
1	Error

### Bit 3 – CMDIDX Command Index Error

This bit is set to 1 if a Command Index error occurs in the command response.

This bit can only be set to 1 if EISTER.CMDIDX is set to 1. An interrupt can only be generated if EISIER.CMDIDX is set to 1.

Writing this bit to 1 clears this bit.

Value	Description
0	No error
1	Error

### Bit 2 – CMDEND Command End Bit Error

This bit is set to 1 when detecting that the end bit of a command response is 0.

This bit can only be set to 1 if EISTER.CMDEND is set to 1. An interrupt can only be generated if EISIER.CMDEND is set to 1.

Writing this bit to 1 clears this bit.

Value	Description
0	No error
1	Error

### Bit 1 – CMDCRC Command CRC Error

The Command CRC Error is generated in two cases.

If a response is returned and Command Timeout Error (CMDTEO) is set to 0 (indicating no command timeout), this bit is set to 1 when detecting a CRC error in the command response.

The peripheral detects a CMD line conflict by monitoring the CMD line when a command is issued. If the peripheral drives the CMD line to 1 level, but detects 0 level on the CMD line at the next SDCLK edge, then the peripheral aborts the command (stops driving the CMD line) and sets this bit to 1. CMDTEO is also set to 1 to indicate a CMD line conflict (refer to [Table 40-2](#)).

This bit can only be set to 1 if EISTER.CMDCRC is set to 1. An interrupt can only be generated if EISIER.CMDCRC is set to 1.

Writing this bit to 1 clears this bit.

### Bit 0 – CMDTEO Command Timeout Error

This bit is set to 1 only if no response is returned within 64 SDCLK cycles from the end bit of the command. If the peripheral detects a CMD line conflict, in which case Command CRC Error (CMDCRC) is also set to 1 (refer to [Table 40-2](#)), this bit is set without waiting for 64 SDCLK cycles because the command is aborted by the peripheral.

This bit can only be set to 1 if EISTER.CMDTEO is set to 1. An interrupt can only be generated if EISIER.CMDTEO is set to 1.

Writing this bit to 1 clears this bit.

**Table 40-2. CMD Error Types**

CMDCRC	CMDTEO	Types of error
0	0	No error
0	1	Response timeout error
1	0	Response CRC error

# SAM D5x/E5x Family Data Sheet

SD/MMC Host Controller ...

.....continued

CMDCRC	CMDTEO	Types of error
1	1	CMD line conflict

### 40.8.19 Normal Interrupt Status Enable Register: e.MMC

**Name:** NISTER  
**Offset:** 0x34  
**Reset:** 0x0000  
**Property:** -

	15	14	13	12	11	10	9	8
		BOOTAR						CINT
Access		R/W						R/W
Reset		0						0
	7	6	5	4	3	2	1	0
	CREM	CINS	BRDRDY	BWRRDY	DMAINT	BLKGE	TRFC	CMDC
Access	R/W	R/W	R/W	R/W	R/W	R/W	R/W	R/W
Reset	0	0	0	0	0	0	0	0

#### Bit 14 – BOOTAR Boot Acknowledge Received Status Enable

**Note:** This register entry is specific to the e.MMC operation mode.

Value	Name	Description
0	MASKED	The BOOTAR status flag in NISTR is masked.
1	ENABLED	The BOOTAR status flag in NISTR is enabled.

#### Bit 8 – CINT Card Interrupt Status Enable

If this bit is set to 0, the peripheral clears interrupt requests to the system. The Card Interrupt detection is stopped when this bit is cleared and restarted when this bit is set to 1. The user may clear this bit before servicing the Card Interrupt and may set this bit again after all interrupt requests from the card are cleared to prevent inadvertent interrupts.

Value	Name	Description
0	MASKED	The CINT status flag in NISTR is masked.
1	ENABLED	The CINT status flag in NISTR is enabled.

#### Bit 7 – CREM Card Removal Status Enable

Value	Name	Description
0	MASKED	The CREM status flag in NISTR is masked.
1	ENABLED	The CREM status flag in NISTR is enabled.

#### Bit 6 – CINS Card Insertion Status Enable

Value	Name	Description
0	MASKED	The CINS status flag in NISTR is masked.
1	ENABLED	The CINS status flag in NISTR is enabled.

#### Bit 5 – BRDRDY Buffer Read Ready Status Enable

Value	Name	Description
0	MASKED	The BRDRDY status flag in NISTR is masked.
1	ENABLED	The BRDRDY status flag in NISTR is enabled.

#### Bit 4 – BWRRDY Buffer Write Ready Status Enable

# SAM D5x/E5x Family Data Sheet

## SD/MMC Host Controller ...

Value	Name	Description
0	MASKED	The BWRRDY status flag in NISTR is masked.
1	ENABLED	The BWRRDY status flag in NISTR is enabled.

### Bit 3 – DMAINT DMA Interrupt Status Enable

Value	Name	Description
0	MASKED	The DMAINT status flag in NISTR is masked.
1	ENABLED	The DMAINT status flag in NISTR is enabled.

### Bit 2 – BLKGE Block Gap Event Status Enable

Value	Name	Description
0	MASKED	The BLKGE status flag in NISTR is masked.
1	ENABLED	The BLKGE status flag in NISTR is enabled.

### Bit 1 – TRFC Transfer Complete Status Enable

Value	Name	Description
0	MASKED	The TRFC status flag in NISTR is masked.
1	ENABLED	The TRFC status flag in NISTR is enabled.

### Bit 0 – CMDC Command Complete Status Enable

Value	Name	Description
0	MASKED	The CMDC status flag in NISTR is masked.
1	ENABLED	The CMDC status flag in NISTR is enabled.

### 40.8.20 Error Interrupt Status Enable Register

**Name:** EISTER  
**Offset:** 0x36  
**Reset:** 0x0000  
**Property:** -

	15	14	13	12	11	10	9	8
				BOOTAE			ADMA	ACMD
Access	R/W				R/W			
Reset	0				0			
	7	6	5	4	3	2	1	0
	CURLIM	DATEND	DATCRC	DATTEO	CMDIDX	CMDEND	CMDCRC	CMDTEO
Access	R/W	R/W	R/W	R/W	R/W	R/W	R/W	R/W
Reset	0	0	0	0	0	0	0	0

#### Bit 12 – BOOTAE Boot Acknowledge Error Status Enable

**Note:** This register entry is specific to the e.MMC operation mode.

Value	Name	Description
0	MASKED	The BOOTAE status flag in EISTR is masked.
1	ENABLED	The BOOTAE status flag in EISTR is enabled.

#### Bit 9 – ADMA ADMA Error Status Enable

Value	Name	Description
0	MASKED	The ADMA status flag in EISTR is masked.
1	ENABLED	The ADMA status flag in EISTR is enabled.

#### Bit 8 – ACMD Auto CMD Error Status Enable

Value	Name	Description
0	MASKED	The ACMD status flag in EISTR is masked.
1	ENABLED	The ACMD status flag in EISTR is enabled.

#### Bit 7 – CURLIM Current Limit Error Status Enable

Value	Name	Description
0	MASKED	The CURLIM status flag in EISTR is masked.
1	ENABLED	The CURLIM status flag in EISTR is enabled.

#### Bit 6 – DATEND Data End Bit Error Status Enable

Value	Name	Description
0	MASKED	The DATEND status flag in EISTR is masked.
1	ENABLED	The DATEND status flag in EISTR is enabled.

#### Bit 5 – DATCRC Data CRC Error Status Enable

Value	Name	Description
0	MASKED	The DATCRC status flag in EISTR is masked.
1	ENABLED	The DATCRC status flag in EISTR is enabled.

**Bit 4 – DATTEO** Data Timeout Error Status Enable

Value	Name	Description
0	MASKED	The DATTEO status flag in EISTR is masked.
1	ENABLED	The DATTEO status flag in EISTR is enabled.

**Bit 3 – CMDIDX** Command Index Error Status Enable

Value	Name	Description
0	MASKED	The CMDIDX status flag in EISTR is masked.
1	ENABLED	The CMDIDX status flag in EISTR is enabled.

**Bit 2 – CMDEND** Command End Bit Error Status Enable

Value	Name	Description
0	MASKED	The CMDEND status flag in EISTR is masked.
1	ENABLED	The CMDEND status flag in EISTR is enabled.

**Bit 1 – CMDCRC** Command CRC Error Status Enable

Value	Name	Description
0	MASKED	The CMDCRC status flag in EISTR is masked.
1	ENABLED	The CMDCRC status flag in EISTR is enabled.

**Bit 0 – CMDTEO** Command Timeout Error Status Enable

Value	Name	Description
0	MASKED	The CMDTEO status flag in EISTR is masked.
1	ENABLED	The CMDTEO status flag in EISTR is enabled.

### 40.8.21 Normal Interrupt Signal Enable Register

**Name:** NISIER  
**Offset:** 0x38  
**Reset:** 0x0000  
**Property:** -

Bit	15	14	13	12	11	10	9	8
		BOOTAR						CINT
Access		R/W						R/W
Reset		0						0
Bit	7	6	5	4	3	2	1	0
	CREM	CINS	BRDRDY	BWRRDY	DMAINT	BLKGE	TRFC	CMDC
Access	R/W	R/W	R/W	R/W	R/W	R/W	R/W	R/W
Reset	0	0	0	0	0	0	0	0

**Bit 14 – BOOTAR** Boot Acknowledge Received Signal Enable

**Note:** This register entry is specific to the e.MMC operation mode.

Value	Name	Description
0	MASKED	No interrupt is generated when NISTR.BOOTAR is set.
1	ENABLED	An interrupt is generated when NISTR.BOOTAR is set.

**Bit 8 – CINT** Card Interrupt Signal Enable

**Note:**

This register entry is specific to the SD/SDIO operation mode.

Value	Name	Description
0	MASKED	No interrupt is generated when NISTR.CINT is set.
1	ENABLED	An interrupt is generated when NISTR.CINT is set.

**Bit 7 – CREM** Card Removal Signal Enable

**Note:**

This register entry is specific to the SD/SDIO operation mode.

Value	Name	Description
0	MASKED	No interrupt is generated when NISTR.CREM is set.
1	ENABLED	An interrupt is generated when NISTR.CREM is set.

**Bit 6 – CINS** Card Insertion Signal Enable

**Note:**

This register entry is specific to the SD/SDIO operation mode.

Value	Name	Description
0	MASKED	No interrupt is generated when NISTR.CINS is set.
1	ENABLED	An interrupt is generated when NISTR.CINS is set.

**Bit 5 – BRDRDY** Buffer Read Ready Signal Enable

Value	Name	Description
0	MASKED	No interrupt is generated when NISTR.BRDRDY is set.

# SAM D5x/E5x Family Data Sheet

## SD/MMC Host Controller ...

Value	Name	Description
1	ENABLED	An interrupt is generated when NISTR.BRDRDY is set.

### Bit 4 – BWRRDY Buffer Write Ready Signal Enable

Value	Name	Description
0	MASKED	No interrupt is generated when NISTR.BWRRDY is set.
1	ENABLED	An interrupt is generated when NISTR.BWRRDY is set.

### Bit 3 – DMAINT DMA Interrupt Signal Enable

Value	Name	Description
0	MASKED	No interrupt is generated when NISTR.DMAINT is set.
1	ENABLED	An interrupt is generated when NISTR.DMAINT is set.

### Bit 2 – BLKGE Block Gap Event Signal Enable

Value	Name	Description
0	MASKED	No interrupt is generated when NISTR.BLKGE is set.
1	ENABLED	An interrupt is generated when NISTR.BLKGE is set.

### Bit 1 – TRFC Transfer Complete Signal Enable

Value	Name	Description
0	MASKED	No interrupt is generated when NISTR.TRFC is set.
1	ENABLED	An interrupt is generated when NISTR.TRFC is set.

### Bit 0 – CMDC Command Complete Signal Enable

Value	Name	Description
0	MASKED	No interrupt is generated when NISTR.CMDC is set.
1	ENABLED	An interrupt is generated when NISTR.CMDC is set.



### 40.8.22 Error Interrupt Signal Enable Register

**Name:** EISIER  
**Offset:** 0x3A  
**Reset:** 0x0000  
**Property:** -

	15	14	13	12	11	10	9	8
				BOOTAE			ADMA	ACMD
Access				R/W				R/W
Reset				0				0
	7	6	5	4	3	2	1	0
	CURLIM	DATEND	DATCRC	DATTEO	CMDIDX	CMDEND	CMDCRC	CMDTEO
Access	R/W	R/W	R/W	R/W	R/W	R/W	R/W	R/W
Reset	0	0	0	0	0	0	0	0

**Bit 12 – BOOTAE** Boot Acknowledge Error Signal Enable

**Note:** This register entry is specific to the e.MMC operation mode.

Value	Name	Description
0	MASKED	No interrupt is generated when EISTR.BOOTAE is set.
1	ENABLED	An interrupt is generated when EISTR.BOOTAE is set.

**Bit 9 – ADMA** ADMA Error Signal Enable

Value	Name	Description
0	MASKED	No interrupt is generated when EISTR.ADMA is set.
1	ENABLED	An interrupt is generated when EISTR.ADMA is set.

**Bit 8 – ACMD** Auto CMD Error Signal Enable

Value	Name	Description
0	MASKED	No interrupt is generated when EISTR.ACMD is set.
1	ENABLED	An interrupt is generated when EISTR.ACMD is set.

**Bit 7 – CURLIM** Current Limit Error Signal Enable

Value	Name	Description
0	MASKED	No interrupt is generated when EISTR.CURLIM is set.
1	ENABLED	An interrupt is generated when EISTR.CURLIM is set.

**Bit 6 – DATEND** Data End Bit Error Signal Enable

Value	Name	Description
0	MASKED	No interrupt is generated when EISTR.DATEND is set.
1	ENABLED	An interrupt is generated when EISTR.DATEND is set.

**Bit 5 – DATCRC** Data CRC Error Signal Enable

Value	Name	Description
0	MASKED	No interrupt is generated when EISTR.DATCRC is set.
1	ENABLED	An interrupt is generated when EISTR.DATCRC is set.

**Bit 4 – DATTEO** Data Timeout Error Signal Enable

Value	Name	Description
0	MASKED	No interrupt is generated when EISTR.DATTEO is set.
1	ENABLED	An interrupt is generated when EISTR.DATTEO is set.

**Bit 3 – CMDIDX** Command Index Error Signal Enable

Value	Name	Description
0	MASKED	No interrupt is generated when EISTR.CMDIDX is set.
1	ENABLED	An interrupt is generated when EISTR.CMDIDX is set.

**Bit 2 – CMDEND** Command End Bit Error Signal Enable

Value	Name	Description
0	MASKED	No interrupt is generated when EISTR.CMDEND is set.
1	ENABLED	An interrupt is generated when EISTR.CMDEND is set.

**Bit 1 – CMDCRC** Command CRC Error Signal Enable

Value	Name	Description
0	MASKED	No interrupt is generated when EISTR.CMDCRC is set.
1	ENABLED	An interrupt is generated when EISTR.CMDCRC is set.

**Bit 0 – CMDTEO** Command Timeout Error Signal Enable

Value	Name	Description
0	MASKED	No interrupt is generated when EISTR.CMDTEO is set.
1	ENABLED	An interrupt is generated when EISTR.CMDTEO is set.

### 40.8.23 Auto CMD Error Status Register

**Name:** ACESR  
**Offset:** 0x3C  
**Reset:** 0x0000  
**Property:** -

	Bit	15	14	13	12	11	10	9	8
Access									
Reset									
	Bit	7	6	5	4	3	2	1	0
		CMDNI			ACMDIDX	ACMDEND	ACMDCRC	ACMDTEO	ACMD12NE
Access		R			R	R	R	R	R
Reset		0			0	0	0	0	0

**Bit 7 – CMDNI** Command Not Issued by Auto CMD12 Error  
 Setting this bit to 1 means CMD\_wo\_DAT is not executed due to an Auto CMD12 error (ACESR[4:1]). This bit is set to 0 when Auto CMD Error is generated by Auto CMD23.

Value	Description
0	No error
1	Error

**Bit 4 – ACMDIDX** Auto CMD Index Error  
 This bit is set to 1 when the Command Index error occurs in response to a command.

Value	Description
0	No error
1	Error

**Bit 3 – ACMDEND** Auto CMD End Bit Error  
 This bit is set to 1 when detecting that the end bit of the command response is 0.

Value	Description
0	No error
1	Error

**Bit 2 – ACMDCRC** Auto CMD CRC Error  
 This bit is set to 1 when detecting a CRC error in the command response (refer to [Table 1-7](#) for more details).

**Bit 1 – ACMDTEO** Auto CMD Timeout Error  
 This bit is set to 1 if no response is returned within 64 SDCLK cycles from the end bit of the command. If this bit is set to 1, the other error status bits (ACESR[4:2]) are meaningless.

ACMDCRC	ACMDTEO	Types of error
0	0	No error
0	1	Response Timeout error

# SAM D5x/E5x Family Data Sheet

## SD/MMC Host Controller ...

.....continued

ACMDCRC	ACMDTEO	Types of error
1	0	Response CRC error
1	1	CMD line conflict

### Bit 0 – ACMD12NE Auto CMD12 Not Executed

If a memory multiple block data transfer is not started due to a command error, this bit is not set to 1 because it is not necessary to issue Auto CMD12. Setting this bit to 1 means the peripheral cannot issue Auto CMD12 to stop a memory multiple block data transfer due to some error. If this bit is set to 1, other error status bits (ACESR[4:1]) are meaningless.

This bit is set to 0 when an Auto CMD error is generated by Auto CMD23.

Value	Description
0	No error
1	Error

### 40.8.24 Host Control 2 Register: e.MMC

**Name:** HC2R - EMMC  
**Offset:** 0x3E  
**Reset:** 0x0000  
**Property:** -

**Note:** The content of the HC2R register is depending on the mode. This description is for e.MMC mode. For SD/SDIO mode, see [40.8.25 HC2R - DEFAULT](#).

	Bit	15	14	13	12	11	10	9	8
		PVALEN							
Access		R/W							
Reset		0							
	Bit	7	6	5	4	3	2	1	0
		SCLKSEL		EXTUN		DRVSEL[1:0]		HS200EN[3:0]	
Access		R/W	R/W	R/W	R/W	R/W	R/W	R/W	R/W
Reset		0	0	0	0	0	0	0	0

#### Bit 15 – PVALEN Preset Value Enable

As the operating SDCLK frequency depends on the system implementation, it is difficult to determine these parameters in the standard host driver. When Preset Value Enable (PVALEN) is set to 1, automatic SDCLK frequency generation is performed without considering system-specific conditions. This bit enables the functions defined in PVR.

If this bit is written to 0, the Clock Generator Select bit (CCR.CLKGSEL) and the SDCLK Frequency Select bit (CCR.SDCLKFSEL) in the Clock Control Register (CCR) are selected by the user.

If this bit is set to 1, CCR.SDCLKFSEL and .CLKGSEL and HC2R.DRVSEL are set by the peripheral as specified in the Preset Value Register (PVR).

Value	Description
0	CCR.SDCLK, CCR.SDCLKFSEL controlled by the user.
1	Automatic selection by Preset Value is enabled.

#### Bit 7 – SCLKSEL Sampling Clock Select

The peripheral uses this bit to select the sampling clock to receive CMD and DAT.

This bit is set by the tuning procedure and is valid after completion of tuning (when EXTUN is cleared).

Setting 1 means that tuning is completed successfully and setting 0 means that tuning has failed.

Writing 1 to this bit is meaningless and ignored. A tuning circuit is reset by writing to 0. This bit can be cleared by setting EXTUN to 1. Once the tuning circuit is reset, it takes time to complete a tuning sequence. Therefore, the user should keep this bit to 1 to perform a re-tuning sequence to complete a re-tuning sequence in a short time. Changing this bit is not allowed while the peripheral is receiving a response or a read data block. Refer to Figure 2.29 in the “SD Host Controller Simplified Specification V3.00”.

Value	Description
0	The fixed clock is used to sample data.
1	The tuned clock is used to sample data.

### Bit 6 – EXTUN Execute Tuning

This bit is set to 1 to start the tuning procedure and is automatically cleared when the tuning procedure is completed. The result of tuning is indicated to Sampling Clock Select (SCLKSEL). The tuning procedure is aborted by writing 0. Refer to Figure 2.29 in the “SD Host Controller Simplified Specification V3.00” .

Value	Description
0	Not tuned or tuning completed
1	Execute tuning

### Bits 5:4 – DRVSEL[1:0] Driver Strength Select

The peripheral output driver in 1.8V signaling is selected by this bit. In 3.3V signaling, this field is not effective. This field can be set according to the Driver Type A, C and D support bits in CA1R.

This field depends on setting of Preset Value Enable (PVALEN):

- PVALEN=0 - This field is set by the user.
- PVALEN=1 - This field is automatically set by a value specified in one of the PVRx.

Value	Name	Description
0	TYPEB	Driver Type B is selected (Default)
1	TYPEA	Driver Type A is selected
2	TYPEC	Driver Type C is selected
3	TYPED	Driver Type D is selected

### Bits 3:0 – HS200EN[3:0] HS200 Mode Enable

This field is used to select the e.MMC HS200 mode. When HS200EN is set to B<sub>(hexa)</sub>, the HS200 mode is enabled. Any other value except 0 is forbidden when interfacing an e.MMC device.

If Preset Value Enable is set to 1, peripheral sets SDCLK Frequency Select (SDCLKFSEL), Clock Generator Select (CLKGSEL) in CCR and Driver Strength Select (DRVSEL) according to PVR. In this case, one of the preset value registers is selected by this field. The user needs to reset SD Clock Enable (SDCLKEN) before changing this field to avoid generating a clock glitch. After setting this field, the user sets SDCLKEN to 1 again.

**Note:** This field is effective only if MC1R.DDR is written to 0.

### 40.8.25 Host Control 2 Register: SD/SDIO

**Name:** HC2R - DEFAULT  
**Offset:** 0x3E  
**Reset:** 0x0000  
**Property:** -

**Note:** The content of the HC2R register is depending on the mode. This description is for SD/SDIO mode. For e.MMC mode, see [40.8.24 HC2R - EMMC](#).

	15	14	13	12	11	10	9	8
	PVALEN	ASINTEN						
Access	R/W	R/W						
Reset	0	0						
	7	6	5	4	3	2	1	0
	SCLKSEL	EXTUN	DRVSEL[1:0]		VS18EN		UHSMS[2:0]	
Access	R/W	R/W	R/W	R/W	R/W	R/W	R/W	R/W
Reset	0	0	0	0	0	0	0	0

#### Bit 15 – PVALEN Preset Value Enable

As the operating SDCLK frequency depends on the system implementation, it is difficult to determine these parameters in the standard host driver. When Preset Value Enable (PVALEN) is set to 1, automatic SDCLK frequency generation is performed without considering system-specific conditions. This bit enables the functions defined in PVR.

If this bit is written to 0, the Clock Generator Select bit (CCR.CLKGSEL) and the SDCLK Frequency Select bit (CCR.SDCLKFSEL) in the Clock Control Register (CCR) are selected by the user.

If this bit is set to 1, CCR.SDCLKFSEL and .CLKGSEL and HC2R.DRVSEL are set by the peripheral as specified in the Preset Value Register (PVR).

Value	Description
0	CCR.SDCLK, CCR.SDCLKFSEL controlled by the user.
1	Automatic selection by Preset Value is enabled.

#### Bit 14 – ASINTEN Asynchronous Interrupt Enable

This bit can be set to 1 if a card support asynchronous interrupts and Asynchronous Interrupt Support (ASINTSUP) is set to 1 in CA0R. Asynchronous interrupt is effective when DAT[1] interrupt is used in 4-bit SD mode. If this bit is set to 1, the user can stop the SDCLK during the asynchronous interrupt period to save power. During this period, the peripheral continues to deliver the Card Interrupt to the host when it is asserted by the card.

Value	Description
0	Disabled
1	Enabled

#### Bit 7 – SCLKSEL Sampling Clock Select

The peripheral uses this bit to select the sampling clock to receive CMD and DAT.

This bit is set by the tuning procedure and is valid after completion of tuning (when EXTUN is cleared). Setting 1 means that tuning is completed successfully and setting 0 means that tuning has failed.

Writing 1 to this bit is meaningless and ignored. A tuning circuit is reset by writing to 0. This bit can be cleared by setting EXTUN to 1. Once the tuning circuit is reset, it takes time to complete the tuning sequence. Therefore, the user should keep this bit to 1 to perform a re-tuning sequence to complete a re-

tuning sequence in a short time. Changing this bit is not allowed while the peripheral is receiving a response or a read data block. Refer to Figure 2.29 in the “SD Host Controller Simplified Specification V3.00” .

Value	Description
0	The fixed clock is used to sample data.
1	The tuned clock is used to sample data.

### Bit 6 – EXTUN Execute Tuning

This bit is set to 1 to start the tuning procedure and is automatically cleared when the tuning procedure is completed. The result of tuning is indicated to Sampling Clock Select (SCLKSEL). The tuning procedure is aborted by writing 0. Refer to Figure 2.29 in the “SD Host Controller Simplified Specification V3.00” .

Value	Description
0	Not tuned or tuning completed
1	Execute tuning

### Bits 5:4 – DRVSEL[1:0] Driver Strength Select

The peripheral output driver in 1.8V signaling is selected by this bit. In 3.3V signaling, this field is not effective. This field can be set according to the Driver Type A, C and D support bits in CA1R.

This field depends on setting of Preset Value Enable (PVALEN):

- PVALEN=0 - This field is set by the user.
- PVALEN=1 - This field is automatically set by a value specified in one of the PVRx.

Value	Name	Description
0	TYPEB	Driver Type B is selected (Default)
1	TYPEA	Driver Type A is selected
2	TYPEC	Driver Type C is selected
3	TYPED	Driver Type D is selected

### Bit 3 – VS18EN 1.8V Signaling Enable

This bit controls the voltage regulator for the I/O cell. 3.3V is supplied to the card regardless of the signaling voltage.

Setting this bit from 0 to 1 starts changing the signal voltage from 3.3V to 1.8V. The 1.8V regulator output must be stable within 5 ms.

Clearing this bit from 1 to 0 starts changing the signal voltage from 1.8V to 3.3V. The 3.3V regulator output must be stable within 5ms.

The user can set this bit to 1 when the peripheral supports 1.8V signaling (one of the support bits is set to 1: SDR50SUP, SDR104SUP or DDR50SUP in CA1R) and the card or device supports UHS-I (S18A = 1. Refer to “Bus Switch Voltage Switch Sequence in the “Physical Layer Simplified Specification V3.01” ).

Value	Description
0	3.3V signaling
1	1.8V signaling

### Bits 2:0 – UHSMS[2:0] UHS Mode Select

This field is used to select one of the UHS-I modes and is effective when 1.8V Signal Enable (VS18EN) is set to 1.

If Preset Value Enable is set to 1, the peripheral sets SDCLK Frequency Select (SDCLKFSEL), Clock Generator Select (CLKGSEL) in CCR and Driver Strength Select (DRVSEL) according to PVR. In this case, one of the preset value registers is selected by this field. The user needs to reset SD Clock Enable (SDCLKEN) before changing this field to avoid generating a clock glitch. After setting this field, the user sets SDCLKEN to 1 again.



# SAM D5x/E5x Family Data Sheet

SD/MMC Host Controller ...

Value	Name	Description
0	SDR12	UHS SDR12 Mode
1	SDR25	UHS SDR25 Mode
2	SDR50	UHS SDR50 Mode
3	SDR104	UHS SDR104 Mode
4	DDR50	UHS DDR50 Mode
		Note: This field is effective only if MC1R.DDR is set to 0.

# SAM D5x/E5x Family Data Sheet

## SD/MMC Host Controller ...

### 40.8.26 Capabilities 0 Register

**Name:** CA0R  
**Offset:** 0x40  
**Reset:** 0x27E80080  
**Property:** -

**Note:** The Capabilities 0 Register is not supposed to be written by the user.

	Bit	31	30	29	28	27	26	25	24
		SLTYPE[1:0]		ASINTSUP	SB64SUP		V18VSUP	V30VSUP	V33VSUP
Access		R/W	R/W	R/W	R/W		R/W	R/W	R/W
Reset		0	0	1	0		1	1	1
	Bit	23	22	21	20	19	18	17	16
		SRSUP	SDMASUP	HSSUP		ADMA2SUP	ED8SUP		MAXBLKL
Access		R/W	R/W	R/W		R/W	R/W		R/W
Reset		1	1	1		1	0		0
	Bit	15	14	13	12	11	10	9	8
		BASECLKF[7:0]							
Access		R/W	R/W	R/W	R/W	R/W	R/W	R/W	R/W
Reset		0	0	0	0	0	0	0	0
	Bit	7	6	5	4	3	2	1	0
		TEOCLKU		TEOCLKF[5:0]					
Access		R/W		R/W	R/W	R/W	R/W	R/W	R/W
Reset		1		0	0	0	0	0	0

#### Bits 31:30 – SLTYPE[1:0] Slot Type

This field indicates usage of a slot by a specific system. An peripheral control register set is defined per slot.

Embedded Slot for One Device means that only one non-removable device is connected to a bus slot. The Standard Host Driver controls a removable card (SLTYPE = 0) or one embedded device (SLTYPE = 1) connected to an SD bus slot.

Value	Name
0	Removable Card Slot
1	Embedded Slot for One Device
2	Shared Bus Slot
2	Reserved
3	Reserved

#### Bit 29 – ASINTSUP Asynchronous Interrupt Support

Refer to section “Asynchronous Interrupt” in the “SDIO Simplified Specification V3.00”.

Value	Description
0	Asynchronous interrupt not supported
1	Asynchronous interrupt supported

# SAM D5x/E5x Family Data Sheet

## SD/MMC Host Controller ...

### Bit 28 – SB64SUP 64-Bit System Bus Support

This bit indicates if the peripheral supports the 64-bit Address Descriptor mode and is connected to the 64-bit address system bus.

Value	Description
0	64-bit address bus not supported
1	64-bit address bus supported

### Bit 26 – V18VSUP Voltage Support 1.8V

Value	Description
0	1.8V Voltage supply not supported
1	1.8V Voltage supply supported

### Bit 25 – V30VSUP Voltage Support 3.0V

**Note:** The signal and supply voltages of the peripheral are limited by the supply voltage of the device.

Value	Description
0	3.0V Voltage supply not supported
1	3.0V Voltage supply supported

### Bit 24 – V33VSUP Voltage Support 3.3V

**Note:** The signal and supply voltages of the peripheral are limited by the supply voltage of the device.

Value	Description
0	3.3V Voltage supply not supported
1	3.3V Voltage supply supported

### Bit 23 – SRSUP Suspend/Resume Support

This bit indicates whether the peripheral supports the Suspend/Resume functionality. If this bit is set to 0, the user does not issue either Suspend or Resume commands because the Suspend and Resume mechanism (refer to “Suspend and Resume Mechanism” in the “SD Host Controller Simplified Specification V3.00” ) is not supported.

Value	Description
0	Suspend/Resume not supported
1	Suspend/Resume supported

### Bit 22 – SDMASUP SDMA Support

This bit indicates whether the peripheral is capable of using SDMA to transfer data between system memory and the peripheral directly.

Value	Description
0	SDMA not supported
1	SDMA supported

### Bit 21 – HSSUP High Speed Support

This bit indicates whether the peripheral and the system support High Speed mode and they can supply SDCLK frequency from 25MHz to 50MHz.

Value	Description
0	High Speed not supported
1	High Speed supported

**Bit 19 – ADMA2SUP** ADMA2 Support

This bit indicates whether the peripheral is capable of using ADMA2.

Value	Description
0	ADMA2 not supported
1	ADMA2 supported

**Bit 18 – ED8SUP** 8-Bit Support for Embedded Device

This bit indicates whether the peripheral is capable of using the 8-bit Bus Width mode.

Value	Description
0	8-bit bus width not supported
1	8-bit bus width supported

**Bit 16 – MAXBLKL** Max Block Length

This field indicates the maximum block size that the user can read and write to the buffer in the peripheral.

**Note:** For SD Memory Cards, the transfer block length is always 512 bytes, regardless of this field.

Value	Name	Description
0	512	512 bytes
1	NONE	Reserved

**Bits 15:8 – BASECLKF[7:0]** Base Clock Frequency

This value indicates the frequency of the base clock (BASECLK). The user uses this value to calculate the clock divider value (refer to SDCLK Frequency Select (SDCLKFSEL) in CCR).

If this field is set to 0, the user must get the information via another method.

$$F_{\text{BASECLK}} = \text{BASECLKF}_{\text{MHz}}$$

**Bit 7 – TEOCLKU** Timeout Clock Unit

This bit shows the unit of the base clock frequency used to detect Data Timeout Error.

Value	Description
0	KHz
1	MHz

**Bits 5:0 – TEOCLKF[5:0]** Timeout Clock Frequency

This bit shows the timeout clock frequency (TEOCLK) used to detect Data Timeout Error.

If this field is set to 0, the user must get the information via another method.

The Timeout Clock Unit (TEOCLKU) defines the unit of this field's value.

– TEOCLKU = 0:

$$F_{\text{TEOCLK}} = \text{TEOCLKF}_{\text{KHz}}$$

– TEOCLKU = 1:

$$F_{\text{TEOCLK}} = \text{TEOCLKF}_{\text{MHz}}$$

### 40.8.27 Capabilities 1 Register

**Name:** CA1R  
**Offset:** 0x44  
**Reset:** 0x00000070  
**Property:** -

**Note:** The Capabilities 1 Register is not supposed to be written by the user.

Bit	31	30	29	28	27	26	25	24
Access								
Reset								
Bit	23	22	21	20	19	18	17	16
	CLKMULT[7:0]							
Access	R/W	R/W	R/W	R/W	R/W	R/W	R/W	R/W
Reset	0	0	0	0	0	0	0	0
Bit	15	14	13	12	11	10	9	8
			TSDR50			TCNTRT[3:0]		
Access			R/W			R/W	R/W	R/W
Reset			0			0	0	0
Bit	7	6	5	4	3	2	1	0
			DRVDSUP	DRVCSUP	DRVASUP			SDR50SUP
Access			R/W	R/W	R/W			R/W
Reset			0	0	0			0

#### Bits 23:16 – CLKMULT[7:0] Clock Multiplier

This field indicates the multiplier factor between the Base Clock (BASECLK) used for the Divided Clock Mode and the Multiplied Clock (MULTCLK) used for the Programmable Clock mode (refer to CCR). Reading this field to 0 means that the Programmable Clock mode is not supported.

$$F_{MULTCLK} = F_{BASECLK} \times (CLKMULT + 1)$$

#### Bit 13 – TSDR50 Use Tuning for SDR50

If this bit is set to 1, the peripheral requires tuning to operate SDR50 (tuning is always required to operate SDR104).

Value	Description
0	SDR50 does not require tuning.
1	SDR50 requires tuning.

#### Bits 11:8 – TCNTRT[3:0] Timer Count For Re-Tuning

This field indicates an initial value of the Re-Tuning Timer for Re-Tuning Mode (RTMODE) 1 to 3. Reading this field at 0 means that the Re-Tuning Timer is disabled. The Re-Tuning Timer initial value ranges from 0 to 1024 seconds.

$$T_{TIMER} = 2^{(TCNTRT + 1)} \text{Seconds}$$

#### Bit 6 – DRVDSUP Driver Type D Support

# SAM D5x/E5x Family Data Sheet

## SD/MMC Host Controller ...

---

---

Value	Description
0	Driver type D is not supported.

### Bit 5 – DRVCSUP Driver Type C Support

Value	Description
0	Driver type C is not supported.

### Bit 4 – DRVASUP Driver Type A Support

Value	Description
0	Driver type A is not supported.

### Bit 2 – DDR50SUP DDR50 Support

Value	Description
0	DDR50 mode is not supported.

### Bit 1 – SDR104SUP SDR104 Support

Value	Description
0	SDR104 mode is not supported.
1	SDR104 mode is supported.

### Bit 0 – SDR50SUP SDR50 Support

Value	Description
0	SDR50 mode is not supported.
1	SDR50 mode is supported.

### 40.8.28 Maximum Current Capabilities Register

**Name:** MCCAR  
**Offset:** 0x48  
**Reset:** 0x00000000  
**Property:** -

	31	30	29	28	27	26	25	24
Access								
Reset								
	23	22	21	20	19	18	17	16
	MAXCUR18V[7:0]							
Access	R	R	R	R	R	R	R	R
Reset	0	0	0	0	0	0	0	0
	15	14	13	12	11	10	9	8
	MAXCUR30V[7:0]							
Access	R	R	R	R	R	R	R	R
Reset	0	0	0	0	0	0	0	0
	7	6	5	4	3	2	1	0
	MAXCUR33V[7:0]							
Access	R	R	R	R	R	R	R	R
Reset	0	0	0	0	0	0	0	0

**Bits 23:16 – MAXCUR18V[7:0] Maximum Current for 1.8V**

This field indicates the maximum current capability for 1.8V voltage. This value is meaningful only if V18VSUP is set to 1 in CA0RCA1R. Reading MAXCUR18V at 0 means that the user must get information via another method.

$$I_{max_{mA}} = 4 \times \text{MAXCURR18V}$$

**Bits 15:8 – MAXCUR30V[7:0] Maximum Current for 3.0V**

This field indicates the maximum current capability for 3.0V voltage. This value is meaningful only if V30VSUP is set to 1 in CA0R. Reading MAXCUR30V at 0 means that the user must get information via another method.

$$I_{max_{mA}} = 4 \times \text{MAXCURR30V}$$

**Bits 7:0 – MAXCUR33V[7:0] Maximum Current for 3.3V**

This field indicates the maximum current capability for 3.3V voltage. This value is meaningful only if V33VSUP is set to 1 in CA0R. Reading MAXCUR33V at 0 means that the user must get information via another method.

$$I_{max_{mA}} = 4 \times \text{MAXCURR33V}$$

### 40.8.29 Force Event Register for Auto CMD Error Status

**Name:** FERACES  
**Offset:** 0x50  
**Reset:** 0x0000  
**Property:** -

	15		14		13		12		11		10		9		8
Access															
Reset															
	7		6		5		4		3		2		1		0
	CMDNI				ACMDIDX	ACMDEND	ACMDCRC	ACMDTEO	ACMD12NE						
Access	W				W	W	W	W	W	W					
Reset	0				0	0	0	0	0	0					

**Bit 7 – CMDNI** Force Event for Command Not Issued by Auto CMD12 Error  
 For testing purposes, the user can write this bit to 1 to rise the CMDNI status flag in ACESR.  
 Writing this bit to 0 has no effect.

**Bit 4 – ACMDIDX** Force Event for Auto CMD Index Error  
 For testing purposes, the user can write this bit to 1 to rise the ACMDIDX status flag in ACESR.  
 Writing this bit to 0 has no effect.

**Bit 3 – ACMDEND** Force Event for Auto CMD End Bit Error  
 For testing purposes, the user can write this bit to 1 to rise the ACMDEND status flag in ACESR.  
 Writing this bit to 0 has no effect.

**Bit 2 – ACMDCRC** Force Event for Auto CMD CRC Error  
 For testing purposes, the user can write this bit to 1 to rise the ACMDCRC status flag in ACESR.  
 Writing this bit to 0 has no effect.

**Bit 1 – ACMDTEO** Force Event for Auto CMD Timeout Error  
 For testing purposes, the user can write this bit to 1 to rise the ACMDTEO status flag in ACESR.  
 Writing this bit to 0 has no effect.

**Bit 0 – ACMD12NE** Force Event for Auto CMD12 Not Executed  
 For testing purposes, the user can write this bit to 1 to rise the ACMD12NE status flag in ACESR.  
 Writing this bit to 0 has no effect.



### 40.8.30 Force Event Register for Error Interrupt Status

**Name:** FEREIS  
**Offset:** 0x52  
**Reset:** 0x0000  
**Property:** -

	15	14	13	12	11	10	9	8
				BOOTAE			ADMA	ACMD
Access				W			W	W
Reset				0			0	0
	7	6	5	4	3	2	1	0
	CURLIM	DATEND	DATCRC	DATTEO	CMDIDX	CMDEND	CMDCRC	CMDTEO
Access	W	W	W	W	W	W	W	W
Reset	0	0	0	0	0	0	0	0

**Bit 12 – BOOTAE** Force Event for Boot Acknowledge Error  
 For testing purposes, the user can write this bit to 1 to rise the BOOTAE status flag in EISTR.  
 Writing this bit to 0 has no effect.

**Bit 9 – ADMA** Force Event for ADMA Error  
 For testing purposes, the user can write this bit to 1 to rise the ADMA status flag in EISTR.  
 Writing this bit to 0 has no effect.

**Bit 8 – ACMD** Force Event for Auto CMD Error  
 For testing purposes, the user can write this bit to 1 to rise the ACMD status flag in EISTR.  
 Writing this bit to 0 has no effect.

**Bit 7 – CURLIM** Force Event for Current Limit Error  
 For testing purposes, the user can write this bit to 1 to rise the CURLIM status flag in EISTR.  
 Writing this bit to 0 has no effect.

**Bit 6 – DATEND** Force Event for Data End Bit Error  
 For testing purposes, the user can write this bit to 1 to rise the DATEND status flag in EISTR.  
 Writing this bit to 0 has no effect.

**Bit 5 – DATCRC** Force Event for Data CRC error  
 For testing purposes, the user can write this bit to 1 to rise the DATCRC status flag in EISTR.  
 Writing this bit to 0 has no effect.

**Bit 4 – DATTEO** Force Event for Data Timeout error  
 For testing purposes, the user can write this bit to 1 to rise the DATTEO status flag in EISTR.  
 Writing this bit to 0 has no effect.

**Bit 3 – CMDIDX** Force Event for Command Index Error  
 For testing purposes, the user can write this bit to 1 to rise the CMDIDX status flag in EISTR.  
 Writing this bit to 0 has no effect.

**Bit 2 – CMDEND** Force Event for Command End Bit Error

For testing purposes, the user can write this bit to 1 to rise the CDMEND status flag in EISTR.

Writing this bit to 0 has no effect.

**Bit 1 – CMDCRC** Force Event for Command CRC Error

For testing purposes, the user can write this bit to 1 to rise the CMDCRC status flag in EISTR.

Writing this bit to 0 has no effect.

**Bit 0 – CMDTEO** Force Event for Command Timeout Error

For testing purposes, the user can write this bit to 1 to rise the CMDTEO status flag in EISTR.

Writing this bit to 0 has no effect.

### 40.8.31 ADMA Error Status Register

**Name:** AESR  
**Offset:** 0x54  
**Reset:** 0x00  
**Property:** -

	Bit	7	6	5	4	3	2	1	0
							LMIS	ERRST[1:0]	
Access							R	R	R
Reset							0	0	0

#### Bit 2 – LMIS ADMA Length Mismatch Error

This error occurs in the following two cases:

- While Block Count Enable (BCEN) is being set, the total data length specified by the Descriptor table is different from that specified by the Block Count (BLKCNT) and Transfer Block Size (BLKSIZE).
- The total data length cannot be divided by the Transfer Block Size (BLKSIZE).

Value	Description
0	No error
1	Error

#### Bits 1:0 – ERRST[1:0] ADMA Error State

This field indicates the state of ADMA when an error has occurred during an ADMA data transfer. This field never indicates 2 because ADMA never stops in this state.

Value	Name	Description
0x0	ST_STOP (Stop DMA)	Points to the descriptor following the error descriptor
0x1	ST_FDS (Fetch Descriptor)	Points to the error descriptor
0x2	-	Reserved
0x3	ST_TRF (Transfer Data)	Points to the descriptor following the error descriptor

### 40.8.32 ADMA System Address Register

**Name:** ASAR  
**Offset:** 0x58  
**Reset:** 0x00000000  
**Property:** -

	Bit	31	30	29	28	27	26	25	24
		ADMASA[31:24]							
Access		R/W	R/W	R/W	R/W	R/W	R/W	R/W	R/W
Reset		0	0	0	0	0	0	0	0
	Bit	23	22	21	20	19	18	17	16
		ADMASA[23:16]							
Access		R/W	R/W	R/W	R/W	R/W	R/W	R/W	R/W
Reset		0	0	0	0	0	0	0	0
	Bit	15	14	13	12	11	10	9	8
		ADMASA[15:8]							
Access		R/W	R/W	R/W	R/W	R/W	R/W	R/W	R/W
Reset		0	0	0	0	0	0	0	0
	Bit	7	6	5	4	3	2	1	0
		ADMASA[7:0]							
Access		R/W	R/W	R/W	R/W	R/W	R/W	R/W	R/W
Reset		0	0	0	0	0	0	0	0

**Bits 31:0 – ADMASA[31:0] ADMA System Address**

This field holds the byte address of the executing command of the descriptor table. At the start of ADMA, the user must set the start address of the descriptor table. The ADMA increments this register address, which points to the next Descriptor line to be fetched.

When the ADMA Error (ADMA) status flag rises, this field holds a valid descriptor address depending on the ADMA Error State (ERRST). The user must program Descriptor Table on 32-bit boundary and set 32-bit boundary address to this register. ADMA2 ignores the lower 2 bits of this register and assumes it to be 0.

### 40.8.33 Preset Value Register

**Name:** PVR  
**Offset:** 0x60 + n\*0x02 [n=0..7]  
**Reset:** 0x0000  
**Property:** Read/Write

One of the Preset Value Registers is effective based on the selected bus speed mode. The table below defines the conditions to select one of the PVRs.

**Table 40-3. Preset Value Register Select Condition**

Selected Bus Speed Mode	VS18EN (HC2R)	HSEN (HC1R)	UHSMS (HC2R)
Default Speed	0	0	don't care
High Speed	0	Response Timeout Error	don't care
Reserved	1	don't care	Other values

The following table shows the effective Preset Value Register according to the Selected Bus Speed mode.

**Table 40-4. Preset Value Registers**

PVRx	Selected Bus Speed Mode	Signal Voltage
PVR0	Initialization	3.3V or 1.8V
PVR1	Default Speed	3.3V
PVR2	High Speed	3.3V

When Preset Value Enable (PVALEN) in HC2R is set to 1, SDCLK Frequency Select (SDLCKFSEL) and Clock Generator Select (CLKGSEL) in CCR are automatically set based on the Selected Bus Speed mode. This means that the user does not need to set these fields when preset is enabled. A Preset Value Register for Initialization (PVR0) is not selected by Bus Speed mode. Before starting the initialization sequence, the user needs to set a clock preset value to SDLCKFSEL in CCR. PVALEN can be set to 1 after the initialization is completed.

**Note:** Preset Values in PVRx registers are not supposed to be written by the user. However, the user can modify preset values only if Capabilities Write Enable (CAPWREN) is written to 1 in CACR.

# SAM D5x/E5x Family Data Sheet

## SD/MMC Host Controller ...

Bit	15	14	13	12	11	10	9	8
						CLKGSEL	SDCLKFSEL[9:8]	
Access						R/W	R/W	R/W
Reset						0	0	0
Bit	7	6	5	4	3	2	1	0
	SDCLKFSEL[7:0]							
Access	R/W	R/W	R/W	R/W	R/W	R/W	R/W	R/W
Reset	0	0	0	0	0	0	0	0

**Bit 10 – CLKGSEL** Clock Generator Select  
Refer to CGGSEL in CCR.

**Bits 9:0 – SDCLKFSEL[9:0]** SDCLK Frequency Select  
Refer to SDCLKFSEL in CCR.

### 40.8.34 Slot Interrupt Status Register

**Name:** SISR  
**Offset:** 0xFC  
**Reset:** 0x0000  
**Property:** -

Bit	15	14	13	12	11	10	9	8
Access								
Reset								
Bit	7	6	5	4	3	2	1	0
	INTSSL[7:0]							
Access	R	R	R	R	R	R	R	R
Reset	0	0	0	0	0	0	0	0

**Bits 7:0 – INTSSL[7:0]** Interrupt Signal for Each Slot

These status bits indicate the logical OR of Interrupt Signals and WakeUp Signal for each peripheral instance in the device. INTSSL[x] corresponds to instance SDHCx. There are 2 instances in this device.

### 40.8.35 Host Controller Version Register

**Name:** HCVR  
**Offset:** 0xFE  
**Reset:** 0x1802  
**Property:** -

	Bit	15	14	13	12	11	10	9	8
		VVER[7:0]							
Access		R	R	R	R	R	R	R	R
Reset		0	0	0	1	1	0	0	0
	Bit	7	6	5	4	3	2	1	0
		SVER[7:0]							
Access		R	R	R	R	R	R	R	R
Reset		0	0	0	0	0	0	1	0

**Bits 15:8 – VVER[7:0]** Vendor Version Number  
 Reserved. Value subject to change. No functionality associated.

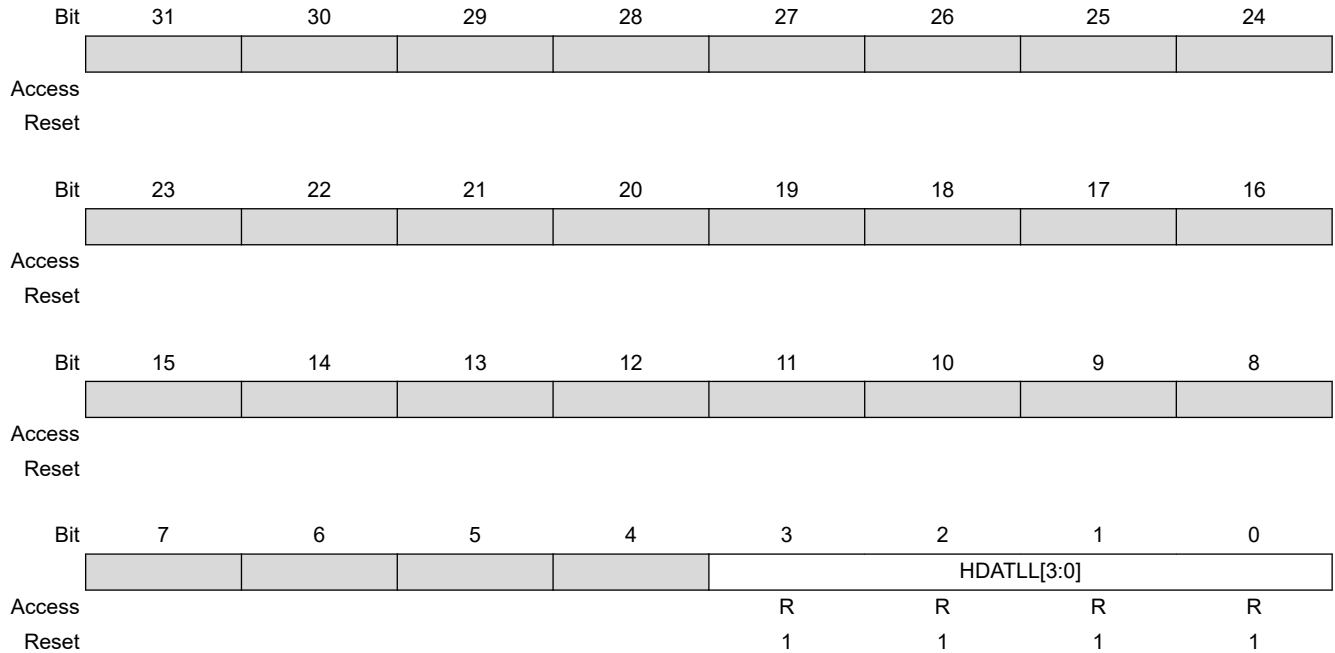
**Bits 7:0 – SVER[7:0]** Specification Version Number  
 This status indicates the SD Host Controller Specification Version.

Value	Name
0	SD Host Specification Version 1.00
1	SD Host Specification Version 2.00, including the feature of the ADMA and Test Register
2	SD Host Specification Version 3.00



### 40.8.36 Additional Present State Register

**Name:** APSR  
**Offset:** 0x200  
**Reset:** 0x0000000F  
**Property:** -



**Bits 3:0 – HDATLL[3:0] High Line Level**

This status is used to check the DAT[7:4] line level to recover from errors, and for debugging.

### 40.8.37 e.MMC Control 1 Register

**Name:** MC1R  
**Offset:** 0x204  
**Reset:** 0x00  
**Property:** R/W

	7	6	5	4	3	2	1	0
	FCD	RSTN	BOOTA	OPD	DDR		CMDTYP[1:0]	
Access	R/W	R/W	R/W	R/W	R/W		R/W	R/W
Reset	0	0	0	0	0		0	0

#### Bit 7 – FCD e.MMC Force Card Detect

When using e.MMC, the user can set this bit to 1 to bypass the card detection procedure using the CD signal.

Value	Name	Description
0	DISABLED	e.MMC Forced Card Detect is disabled. The CD signal is used and debounce timing is applied.
1	ENABLED	e.MMC Forced Card Detect is enabled.

#### Bit 6 – RSTN e.MMC Reset Signal

This bit controls the e.MMC reset signal.

Value	Description
0	Reset signal is inactive.
1	Reset signal is active.

#### Bit 5 – BOOTA e.MMC Boot Acknowledge Enable

This bit must be set according to the value of BOOT\_ACK in the Extended CSD Register (refer to “Embedded MultiMedia Card (e.MMC) Electrical Standard 4.51”).

When this bit is set to 1, the peripheral waits for boot acknowledge pattern from the e.MMC before receiving boot data.

If the boot acknowledge pattern is wrong, the BOOTAE status flag rises in EISTR if BOOTAE is set in EISTER. An interrupt is generated if BOOTAE is set in EISIER.

If the no boot acknowledge pattern is received, the DATTEO status flag rises in EISTR if DATTEO is set in EISTER. An interrupt is generated if DATTEO is set in EISIER.

#### Bit 4 – OPD e.MMC Open Drain Mode

This bit sets the command line in open drain.

Value	Description
0	The command line is in push-pull.
1	The command line is in open drain.

#### Bit 3 – DDR e.MMC HSDDR Mode

This bit selects the High Speed DDR mode.

Value	Description
0	High Speed DDR is not selected.

# SAM D5x/E5x Family Data Sheet

## SD/MMC Host Controller ...

Value	Description
1	High Speed DDR is selected.  Note: The clock divider (DIV) in CCR must be set to a value different from 0 when HSEN is 1.

### Bits 1:0 – CMDTYP[1:0] e.MMC Command Type

Value	Name	Description
0	NORMAL	The command is not an e.MMC specific command.
1	WAITIRQ	This bit must be set to 1 when the e.MMC is in Interrupt mode (CMD40). Refer to “Interrupt Mode” in the “Embedded MultiMedia Card (e.MMC) Electrical Standard 4.51” .
2	STREAM	This bit must be set to 1 in the case of Stream Read(CMD11) or Stream Write (CMD20). Only effective for e.MMC up to revision 4.41.
3	BOOT	Starts a Boot Operation mode at the next write to CR. Boot data are read directly from e.MMC device.

### 40.8.38 e.MMC Control 2 Register

**Name:** MC2R  
**Offset:** 0x205  
**Reset:** 0x00  
**Property:** -

	7	6	5	4	3	2	1	0
							ABOOT	SRESP
Access							W	W
Reset							0	0

**Bit 1 – ABOOT** e.MMC Abort Boot

This bit is used to exit from Boot mode. Writing this bit to 1 exits the Boot Operation mode. Writing 0 is ignored.

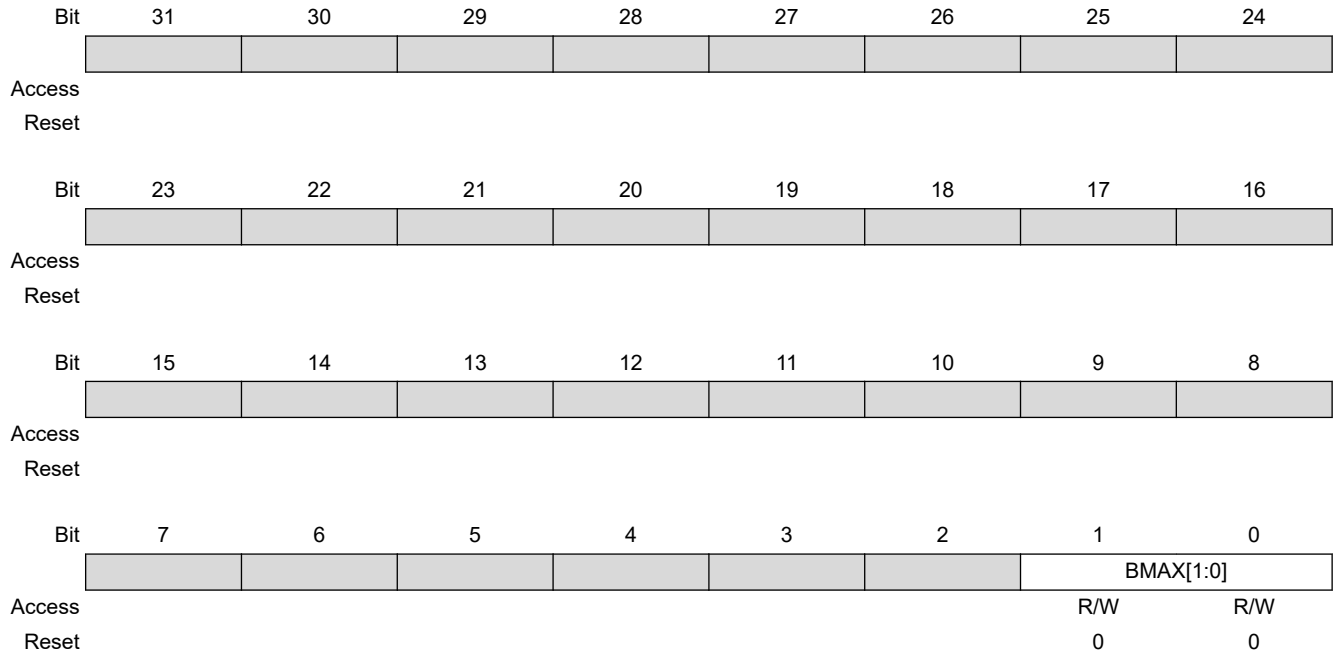
**Bit 0 – SRESP** e.MMC Abort Wait IRQ

This bit is used to exit from the Interrupt mode. When this bit is written to 1, the peripheral sends the CMD40 response automatically. This brings the e.MMC from Interrupt mode to the standard Data Transfer mode. Writing this bit to 0 is ignored.

Note: This bit is only effective when CMD\_TYP in MC1R is set to WAITIRQ.

### 40.8.39 AHB Control Register

**Name:** ACR  
**Offset:** 0x208  
**Reset:** 0x00000000  
**Property:** -



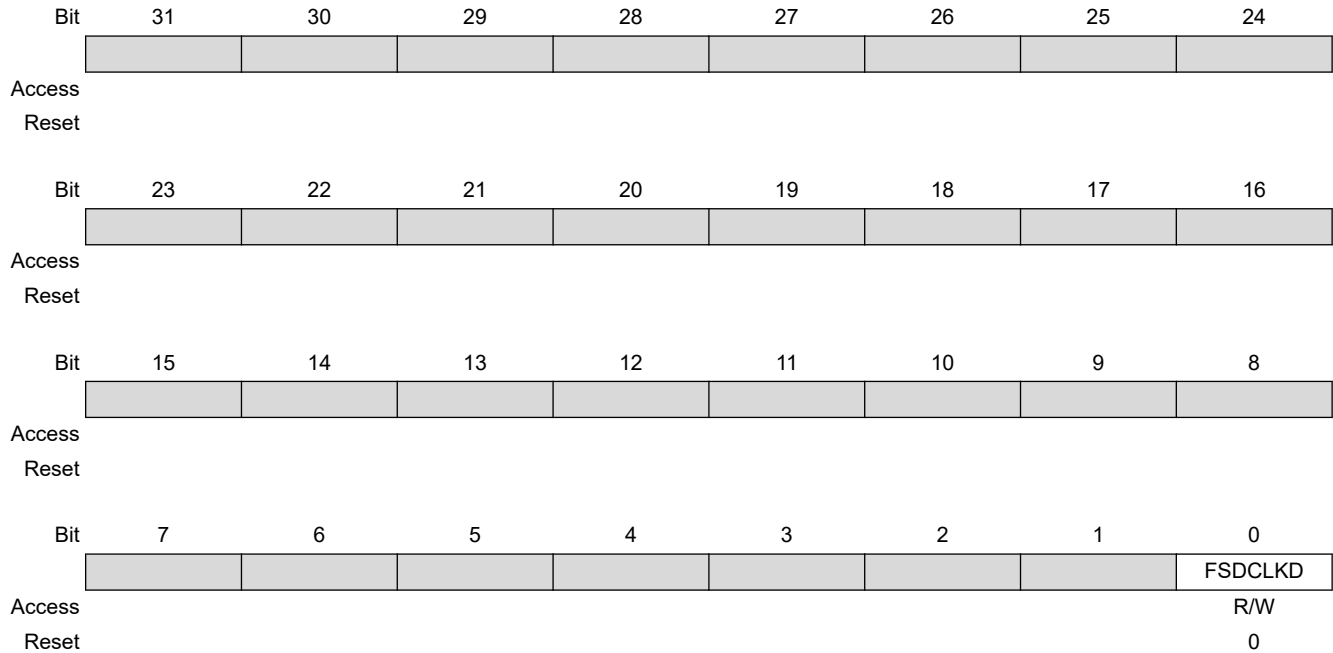
#### Bits 1:0 – BMAX[1:0] AHB Maximum Burst

This field selects the maximum burst size in case of DMA transfer.

Value	Name	Description
0	INCR16	The maximum burst size is INCR16.
1	INCR8	The maximum burst size is INCR8.
2	INCR4	The maximum burst size is INCR4.
3	SINGLE	Only SINGLE transfers are performed.

### 40.8.40 Clock Control 2 Register

**Name:** CC2R  
**Offset:** 0x20C  
**Reset:** 0x00000000  
**Property:** -



**Bit 0 – FSDCLKD** Force SDCLK Disabled

The user can choose to maintain the SDCLK during 8 SDCLK cycles after the end bit of the last data block in case of a read transaction, or after the end bit of the CRC status in case of a write transaction.

Value	Description
0	The SDCLK is forced and it cannot be stopped immediately after the transaction.
1	The SDCLK is not forced and it can be stopped immediately after the transaction.

### 40.8.41 Capabilities Control Register

**Name:** CACR  
**Offset:** 0x230  
**Reset:** 0x00000000  
**Property:** -

	Bit	31	30	29	28	27	26	25	24
		[Greyed out bits 31-24]							
Access									
Reset									
	Bit	23	22	21	20	19	18	17	16
		[Greyed out bits 23-16]							
Access									
Reset									
	Bit	15	14	13	12	11	10	9	8
		KEY[7:0]							
Access	R/W	R/W	R/W	R/W	R/W	R/W	R/W	R/W	R/W
Reset	0	0	0	0	0	0	0	0	0
	Bit	7	6	5	4	3	2	1	0
		[Greyed out bits 7-1]							CAPWREN
Access									R/W
Reset									0

#### Bits 15:8 – KEY[7:0] Key

Value	Name	Description
46h	KEY	Writing any other value in this field aborts the write operation of the CAPWREN bit. Always reads as 0.

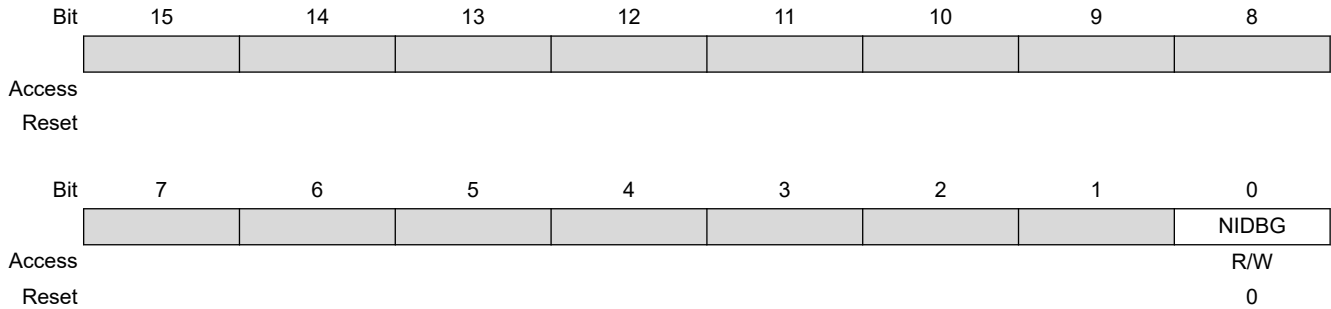
#### Bit 0 – CAPWREN Capabilities Write Enable

This bit can only be written if KEY correspond to 46h.

Value	Description
0	Capabilities registers (CA0R and CA1R) cannot be written.
1	Capabilities registers (CA0R and CA1R) can be written.

### 40.8.42 Debug Register

**Name:** DBGR  
**Offset:** 0x234  
**Reset:** 0x00  
**Property:** -



#### Bit 0 – NIDBG Non-Intrusive Debug

Value	Name	Description
0	DISABLED	Reading the BDPR via debugger increments the dual port RAM read pointer.
1	ENABLED	Reading the BDPR via debugger does not increment the dual port RAM read pointer.



## **41. CCL – Configurable Custom Logic**

### **41.1 Overview**

The Configurable Custom Logic (CCL) is a programmable logic peripheral which can be connected to the device pins, to events, or to other internal peripherals. This allows the user to eliminate logic gates for simple glue logic functions on the PCB.

Each LookUp Table (LUT) consists of three inputs, a truth table, an optional synchronizer/filter, and an optional edge detector. Each LUT can generate an output as a user programmable logic expression with three inputs. Inputs can be individually masked.

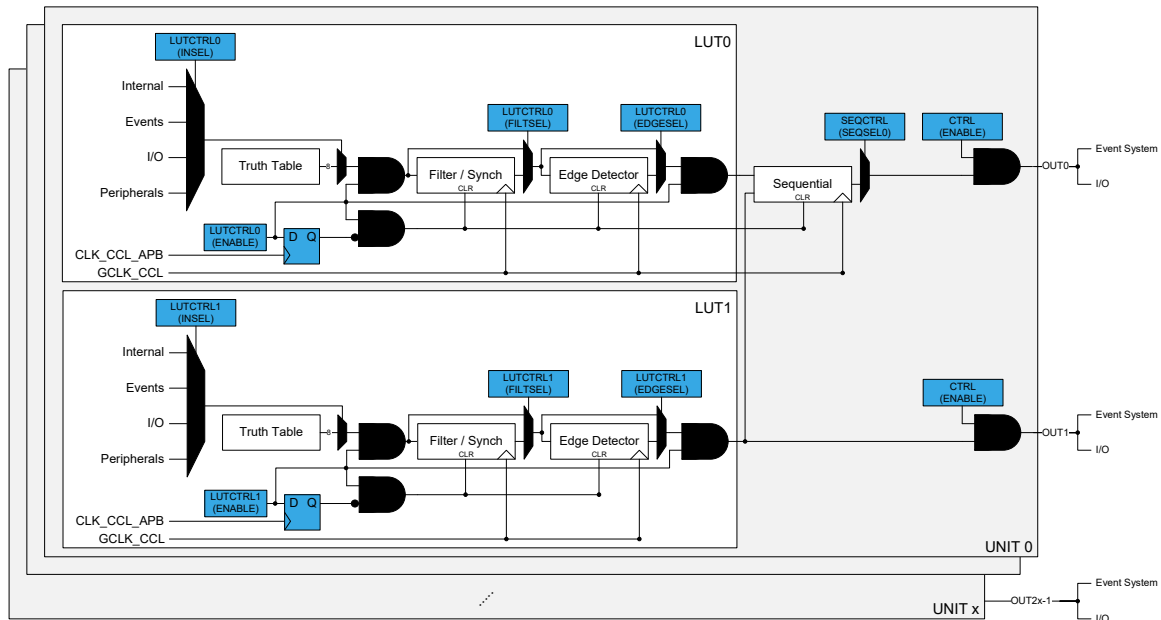
The output can be combinatorially generated from the inputs, and can be filtered to remove spikes. Optional sequential logic can be used. The inputs of the sequential module are individually controlled by two independent, adjacent LUT (LUT0/LUT1, LUT2/LUT3 etc.) outputs, enabling complex waveform generation.

### **41.2 Features**

- Glue logic for general purpose PCB design
- Up to 4 programmable LookUp Tables (LUTs)
- Combinatorial logic functions:  
AND, NAND, OR, NOR, XOR, XNOR, NOT
- Sequential logic functions:  
Gated D Flip-Flop, JK Flip-Flop, gated D Latch, RS Latch
- Flexible LUT inputs selection:
  - I/Os
  - Events
  - Internal peripherals
  - Subsequent LUT output
- Output can be connected to the I/O pins or the Event System
- Optional synchronizer, filter, or edge detector available on each LUT output

### 41.3 Block Diagram

Figure 41-1. Configurable Custom Logic



### 41.4 Signal Description

Pin Name	Type	Description
OUT[n:0]	Digital output	Output from lookup table
IN[3n+2:0]	Digital input	Input to lookup table

- n is the number of CCL groups.

Refer to *I/O Multiplexing and Considerations* for details on the pin mapping for this peripheral. One signal can be mapped on several pins.

#### Related Links

[6. I/O Multiplexing and Considerations](#)

### 41.5 Product Dependencies

In order to use this peripheral, other parts of the system must be configured correctly, as described below.

#### 41.5.1 I/O Lines

The CCL can take inputs and generate output through I/O pins. For this to function properly, the I/O pins must be configured to be used by a Look Up Table (LUT).

#### Related Links

[32. PORT - I/O Pin Controller](#)

### 41.5.2 Power Management

This peripheral can continue to operate in any Sleep mode where its source clock is running. Events connected to the event system can trigger other operations in the system without exiting Sleep modes.

#### Related Links

[18. PM – Power Manager](#)

### 41.5.3 Clocks

The CCL bus clock (CLK\_CCL\_APB) can be enabled and disabled in the Main Clock module, MCLK (see *MCLK - Main Clock*), and the default state of CLK\_CCL\_APB can be found in *Peripheral Clock Masking*.

A generic clock (GCLK\_CCL) is optionally required to clock the CCL. This clock must be configured and enabled in the Generic Clock Controller (GCLK) before using input events, filter, edge detection or sequential logic. GCLK\_CCL is required when input events, a filter, an edge detector, or a sequential sub-module is enabled. Refer to *GCLK - Generic Clock Controller* for details.

This generic clock is asynchronous to the user interface clock (CLK\_CCL\_APB).

#### Related Links

[15. MCLK – Main Clock](#)

[15.6.2.6 Peripheral Clock Masking](#)

[14. GCLK - Generic Clock Controller](#)

### 41.5.4 DMA

Not applicable.

### 41.5.5 Interrupts

Not applicable.

### 41.5.6 Events

The CCL can use events from other peripherals and generate events that can be used by other peripherals. For this feature to function, the events have to be configured properly. Refer to the Related Links below for more information about the event users and event generators.

#### Related Links

[31. EVSYS – Event System](#)

### 41.5.7 Debug Operation

When the CPU is halted in Debug mode the CCL continues normal operation. However, the CCL cannot be halted when the CPU is halted in Debug mode. If the CCL is configured in a way that requires it to be periodically serviced by the CPU, improper operation or data loss may result during debugging.

### 41.5.8 Register Access Protection

All registers with write access can be write-protected optionally by the Peripheral Access Controller (PAC). Refer to *PAC - Peripheral Access Controller* for details.

Optional write protection by the Peripheral Access Controller (PAC) is denoted by the "PAC Write Protection" property in each individual register description.

PAC write protection does not apply to accesses through an external debugger.

#### Related Links

[27. PAC - Peripheral Access Controller](#)

### 41.5.9 Analog Connections

Not applicable.

## 41.6 Functional Description

### 41.6.1 Principle of Operation

Configurable Custom Logic (CCL) is a programmable logic block that can use the device port pins, internal peripherals, and the internal Event System as both input and output channels. The CCL can serve as glue logic between the device and external devices. The CCL can eliminate the need for external logic component and can also help the designer overcome challenging real-time constraints by combining core independent peripherals in clever ways to handle the most time critical parts of the application independent of the CPU.

### 41.6.2 Operation

#### 41.6.2.1 Initialization

The following bits are enable-protected, meaning that they can only be written when the corresponding even LUT is disabled (LUTCTRLx.ENABLE=0):

- Sequential Selection bits in the Sequential Control x (SEQCTRLx.SEQSEL) register

The following registers are enable-protected, meaning that they can only be written when the corresponding LUT is disabled (LUTCTRLx.ENABLE=0):

- LUT Control x (LUTCTRLx) register, except the ENABLE bit

Enable-protected bits in the LUTCTRLx registers can be written at the same time as LUTCTRLx.ENABLE is written to '1', but not at the same time as LUTCTRLx.ENABLE is written to '0'.

Enable-protection is denoted by the Enable-Protected property in the register description.

#### 41.6.2.2 Enabling, Disabling, and Resetting

The CCL is enabled by writing a '1' to the Enable bit in the Control register (CTRL.ENABLE). The CCL is disabled by writing a '0' to CTRL.ENABLE.

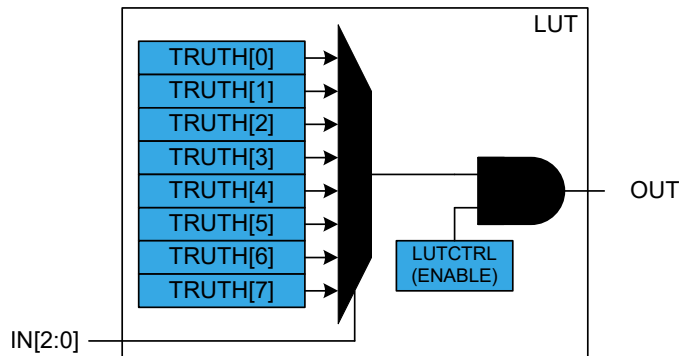
Each LUT is enabled by writing a '1' to the Enable bit in the LUT Control x register (LUTCTRLx.ENABLE). Each LUT is disabled by writing a '0' to LUTCTRLx.ENABLE.

The CCL is reset by writing a '1' to the Software Reset bit in the Control register (CTRL.SWRST). All registers in the CCL will be reset to their initial state, and the CCL will be disabled. Refer to [41.8.1 CTRL](#) for details.

#### 41.6.2.3 Lookup Table Logic

The lookup table in each LUT unit can generate any logic expression OUT as a function of three inputs (IN[2:0]), as shown in [Figure 41-2](#). One or more inputs can be masked. The truth table for the expression is defined by TRUTH bits in LUT Control x register (LUTCTRLx.TRUTH).

**Figure 41-2. Truth Table Output Value Selection**



**Table 41-1. Truth Table of LUT**

IN[2]	IN[1]	IN[0]	OUT
0	0	0	TRUTH[0]
0	0	1	TRUTH[1]
0	1	0	TRUTH[2]
0	1	1	TRUTH[3]
1	0	0	TRUTH[4]
1	0	1	TRUTH[5]
1	1	0	TRUTH[6]
1	1	1	TRUTH[7]

#### 41.6.2.4 Truth Table Inputs Selection

##### Input Overview

The inputs can be individually:

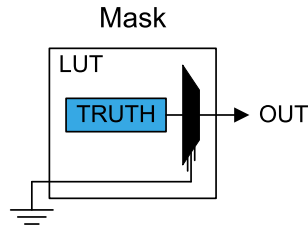
- Masked
- Driven by peripherals:
  - Analog comparator output (AC)
  - Timer/Counters waveform outputs (TC)
  - Serial Communication output transmit interface (SERCOM)
- Driven by internal events from Event System
- Driven by other CCL sub-modules

The Input Selection for each input y of LUT x is configured by writing the Input y Source Selection bit in the LUT x Control register (LUTCTRLx.INSELY).

##### Masked Inputs (MASK)

When a LUT input is masked (LUTCTRLx.INSELY=MASK), the corresponding TRUTH input (IN) is internally tied to zero, as shown in this figure:

**Figure 41-3. Masked Input Selection**



**Internal Feedback Inputs (FEEDBACK)**

When selected (LUTCTRLx.INSELY=FEEDBACK), the Sequential (SEQ) output is used as input for the corresponding LUT.

The output from an internal sequential sub-module can be used as input source for the LUT, see figure below for an example for LUT0 and LUT1. The sequential selection for each LUT follows the formula:

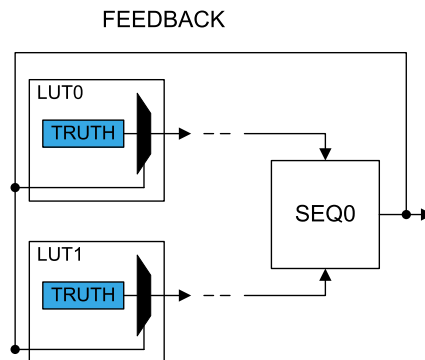
$$IN[2N][i] = SEQ[N]$$

$$IN[2N+1][i] = SEQ[N]$$

With  $N$  representing the sequencer number and  $i=0,1,2$  representing the LUT input index.

For details, refer to [41.6.2.7 Sequential Logic](#).

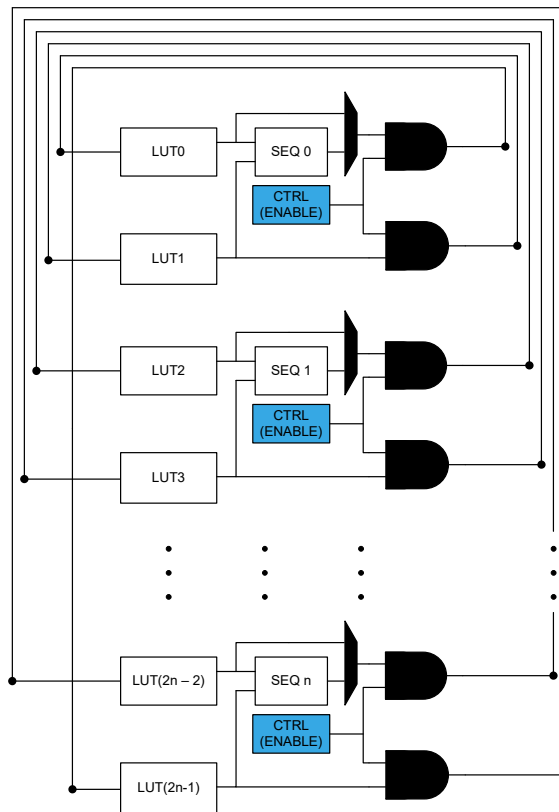
**Figure 41-4. Feedback Input Selection**



**Linked LUT (LINK)**

When selected (LUTCTRLx.INSELY=LINK), the subsequent LUT output is used as the LUT input (e.g., LUT2 is the input for LUT1), as shown in this figure:

**Figure 41-5. Linked LUT Input Selection**



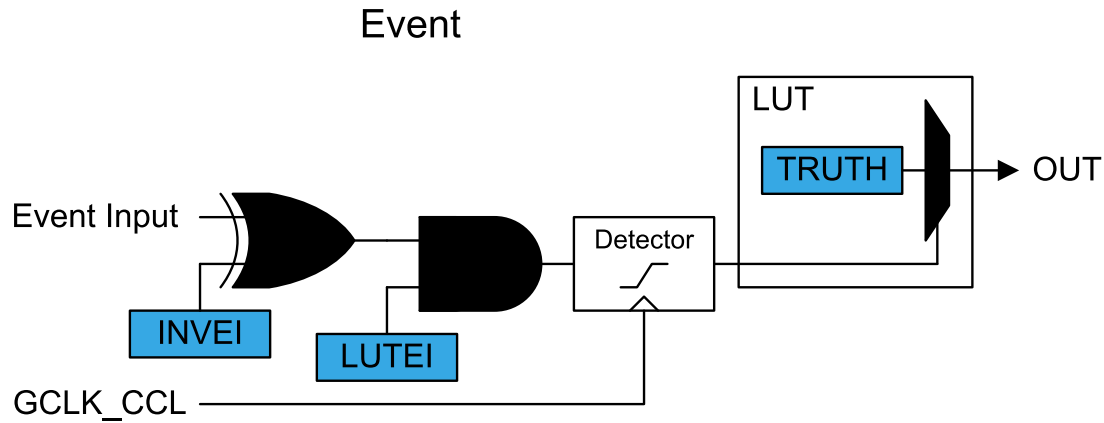
### Internal Events Inputs Selection (EVENT)

Asynchronous events from the Event System can be used as input selection, as shown in the below image. For each LUT, one event input line is available and can be selected on each LUT input. Before enabling the event selection by writing `LUTCTRLx.INSELY=EVENT`, the Event System must be configured first.

By default CCL includes an edge detector. When the event is received, an internal strobe is generated when a rising edge is detected. The pulse duration is one `GCLK_CCL` clock cycle. The following steps ensure proper operation:

1. Enable the `GCLK_CCL` clock.
2. Configure the Event System to route the event asynchronously.
3. Select the event input type (`LUTCTRLx.INSEL`).
4. If a strobe must be generated on the event input falling edge, write a '1' to the Inverted Event Input Enable bit in LUT Control register (`LUTCTRLx.INVEI`).
5. Enable the event input by writing the Event Input Enable bit in LUT Control register (`LUTCTRLx.LUTEI`) to '1'.

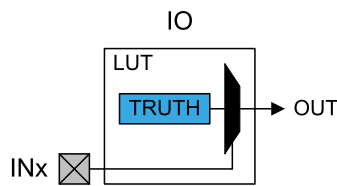
**Figure 41-6. Event Input Selection**



**I/O Pin Inputs (IO)**

When the IO pin is selected as LUT input (LUTCTRLx.INSELY=IO), the corresponding LUT input will be connected to the pin, as shown in the figure below.

**Figure 41-7. I/O Pin Input Selection**



**Analog Comparator Inputs (AC)**

The AC outputs can be used as input source for the LUT (LUTCTRLx.INSELY=AC).

The analog comparator outputs are distributed following the formula:

$$IN[N][i]=AC[N \% \text{ComparatorOutput\_Number}]$$

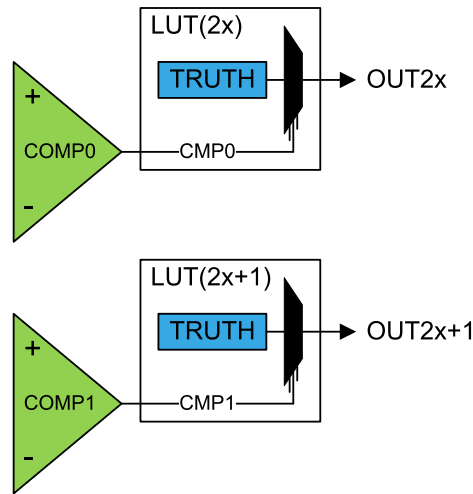
With  $N$  representing the LUT number and  $i=[0,1,2]$  representing the LUT input index.

Before selecting the comparator output, the AC must be configured first.

The output of comparator 0 is available on even LUTs ("LUT(2x)": LUT0, LUT2) and the comparator 1 output is available on odd LUTs ("LUT(2x+1)": LUT1, LUT3), as shown in the figure below.



**Figure 41-8. AC Input Selection**



### Timer/Counter Inputs (TC)

The TC waveform output WO[0] can be used as input source for the LUT (LUTCTRLx.INSELy=TC). Only consecutive instances of the TC, i.e. TCx and the subsequent TC(x+1), are available as default and alternative TC selections (e.g., TC0 and TC1 are sources for LUT0, TC1 and TC2 are sources for LUT1, etc). See the figure below for an example for LUT0. More general, the Timer/Counter selection for each LUT follows the formula:

$$IN[N][i] = \text{DefaultTC}[N \% \text{TC\_Instance\_Number}]$$

$$IN[N][i] = \text{AlternativeTC}[(N + 1) \% \text{TC\_Instance\_Number}]$$

Where N represents the LUT number and i represents the LUT input index (i=0,1,2).

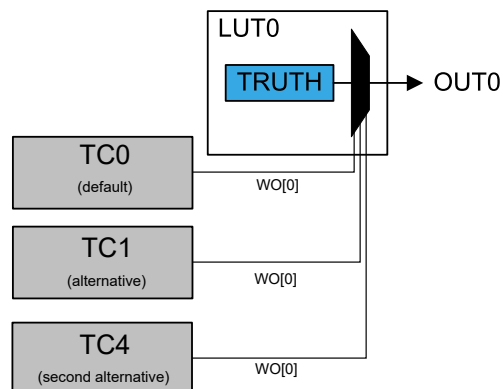
For devices with more than four TC instances, it is also possible to enable a second alternative option (LUTCTRLx.INSEL=ALT2TC). This option is intended to relax the alternative pin function or PCB design constraints when the default or the alternative TC instances are used for other purposes. When enabled, the Timer/Counter selection for each LUT follows the formula:

$$IN[N][i] = \text{SecondAlternativeTC}[(N + 4) \% \text{TC\_Instance\_Number}]$$

Note that for not implemented TC\_Instance\_Number, the corresponding input is tied to ground.

Before selecting the waveform outputs, the TC must be configured first.

**Figure 41-9. TC Input Selection**



### Timer/Counter for Control Application Inputs (TCC)

The TCC waveform outputs can be used as input source for the LUT. Only WO[2:0] outputs can be selected and routed to the respective LUT input (i.e., IN0 is connected to WO0, IN1 to WO1, and IN2 to WO2), as shown in the figure below.

**Note:**

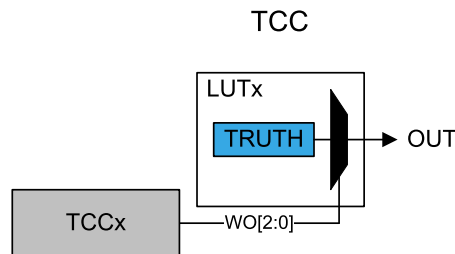
The TCC selection for each LUT follows the formula:

$$IN[N][i] = TCC[N \% TCC\_Instance\_Number]$$

Where  $N$  represents the LUT number.

Before selecting the waveform outputs, the TCC must be configured first.

**Figure 41-10. TCC Input Selection**



### Serial Communication Output Transmit Inputs (SERCOM)

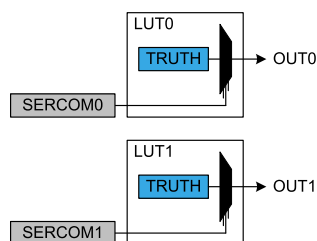
The serial engine transmitter output from Serial Communication Interface (SERCOM TX, TXd for USART, MOSI for SPI) can be used as input source for the LUT. The figure below shows an example for LUT0 and LUT1. The SERCOM selection for each LUT follows the formula:

$$IN[N][i] = SERCOM[N \% SERCOM\_Instance\_Number]$$

With  $N$  representing the LUT number and  $i=0,1,2$  representing the LUT input index.

Before selecting the SERCOM as input source, the SERCOM must be configured first: the SERCOM TX signal must be output on SERCOMn/pad[0], which serves as input pad to the CCL.

**Figure 41-11. SERCOM Input Selection**



**Related Links**

- [6. I/O Multiplexing and Considerations](#)
- [32. PORT - I/O Pin Controller](#)
- [14. GCLK - Generic Clock Controller](#)
- [46. AC – Analog Comparators](#)
- [48. TC – Timer/Counter](#)
- [49. TCC – Timer/Counter for Control Applications](#)
- [33. SERCOM – Serial Communication Interface](#)

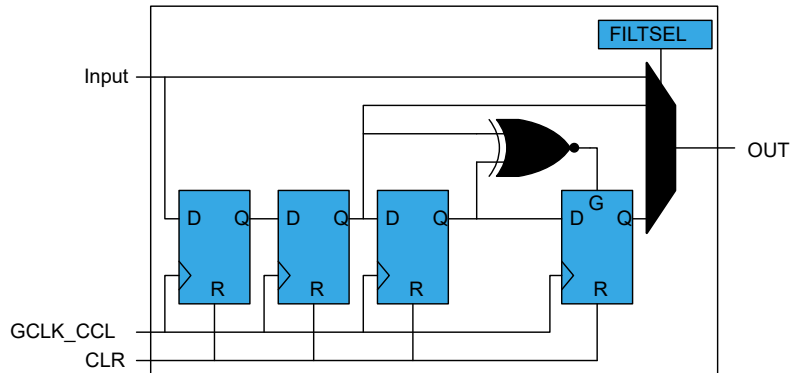
### 41.6.2.5 Filter

By default, the LUT output is a combinatorial function of the LUT inputs. This may cause some short glitches when the inputs change value. These glitches can be removed by clocking through filters, if demanded by application needs.

The Filter Selection bits in LUT Control register (LUTCTRLx.FILTSEL) define the synchronizer or digital filter options. When a filter is enabled, the OUT output will be delayed by two to five GCLK\_CCL cycles. One APB clock after the corresponding LUT is disabled, all internal filter logic is cleared.

**Note:** Events used as LUT input will also be filtered, if the filter is enabled.

**Figure 41-12. Filter**



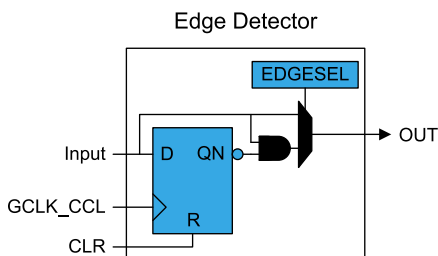
### 41.6.2.6 Edge Detector

The edge detector can be used to generate a pulse when detecting a rising edge on its input. To detect a falling edge, the TRUTH table should be inverted.

The edge detector is enabled by writing '1' to the Edge Selection bit in LUT Control register (LUTCTRLx.EDGESEL). In order to avoid unpredictable behavior, either the filter or synchronizer must be enabled.

Edge detection is disabled by writing a '0' to LUTCTRLx.EDGESEL. After disabling a LUT, the corresponding internal Edge Detector logic is cleared one APB clock cycle later.

**Figure 41-13. Edge Detector**



### 41.6.2.7 Sequential Logic

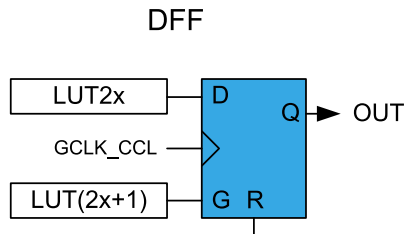
Each LUT pair can be connected to the internal sequential logic which can be configured to work as D flip flop, JK flip flop, gated D-latch or RS-latch by writing the Sequential Selection bits on the corresponding Sequential Control x register (SEQCTRLx.SEQSEL). Before using sequential logic, the GCLK\_CCL clock and optionally each LUT filter or edge detector must be enabled.

**Note:** While configuring the sequential logic, the even LUT must be disabled. When configured the even LUT must be enabled.

### Gated D Flip-Flop (DFF)

When the DFF is selected, the D-input is driven by the even LUT output (LUT0 and LUT2), and the G-input is driven by the odd LUT output (LUT1 and LUT3), as shown in [Figure 41-14](#).

**Figure 41-14. D Flip Flop**



When the even LUT is disabled (LUTCTRL0.ENABLE=0 / LUTCTRL2.ENABLE=0), the flip-flop is asynchronously cleared. The reset command (R) is kept enabled for one APB clock cycle. In all other cases, the flip-flop output (OUT) is refreshed on rising edge of the GCLK\_CCL, as shown in [Table 41-2](#).

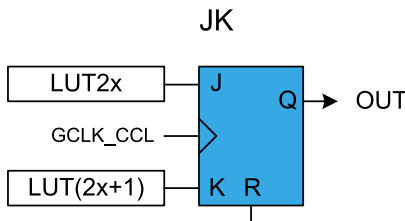
**Table 41-2. DFF Characteristics**

R	G	D	OUT
1	X	X	Clear
0	1	1	Set
		0	Clear
	0	X	Hold state (no change)

### JK Flip-Flop (JK)

When this configuration is selected, the J-input is driven by the even LUT output (LUT0 and LUT2), and the K-input is driven by the odd LUT output (LUT1 and LUT3), as shown in [Figure 41-15](#).

**Figure 41-15. JK Flip Flop**



When the even LUT is disabled (LUTCTRL0.ENABLE=0 / LUTCTRL2.ENABLE=0), the flip-flop is asynchronously cleared. The reset command (R) is kept enabled for one APB clock cycle. In all other cases, the flip-flop output (OUT) is refreshed on rising edge of the GCLK\_CCL, as shown in [Table 41-3](#).

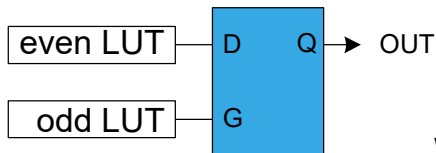
**Table 41-3. JK Characteristics**

R	J	K	OUT
1	X	X	Clear
0	0	0	Hold state (no change)
0	0	1	Clear
0	1	0	Set
0	1	1	Toggle

### Gated D-Latch (DLATCH)

When the DLATCH is selected, the D-input is driven by the even LUT output (LUT0 and LUT2), and the G-input is driven by the odd LUT output (LUT1 and LUT3), as shown in [Figure 41-14](#).

**Figure 41-16. D-Latch**



When the even LUT is disabled (LUTCTRL0.ENABLE=0 / LUTCTRL2.ENABLE=0), the latch output will be cleared. The G-input is forced enabled for one more APB clock cycle, and the D-input to zero. In all other cases, the latch output (OUT) is refreshed as shown in [Table 41-4](#).

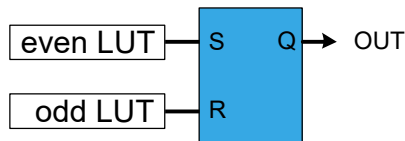
**Table 41-4. D-Latch Characteristics**

G	D	OUT
0	X	Hold state (no change)
1	0	Clear
1	1	Set

### RS Latch (RS)

When this configuration is selected, the S-input is driven by the even LUT output (LUT0 and LUT2), and the R-input is driven by the odd LUT output (LUT1 and LUT3), as shown in [Figure 41-17](#).

**Figure 41-17. RS-Latch**



When the even LUT is disabled (LUTCTRL0.ENABLE=0 / LUTCTRL2.ENABLE=0), the latch output will be cleared. The R-input is forced enabled for one more APB clock cycle and S-input to zero. In all other cases, the latch output (OUT) is refreshed as shown in [Table 41-5](#).

**Table 41-5. RS-Latch Characteristics**

S	R	OUT
0	0	Hold state (no change)
0	1	Clear
1	0	Set
1	1	Forbidden state

#### 41.6.3 Events

The CCL can generate the following output events:

- OUTx: Lookup Table Output Value

Writing a '1' to the LUT Control Event Output Enable bit (LUTCTRL.LUTE0) enables the corresponding output event. Writing a '0' to this bit disables the corresponding output event.

The CCL can take the following actions on an input event:

- INSELx: The event is used as input for the TRUTH table. For further details refer to [41.5.6 Events](#).

Writing a '1' to the LUT Control Event Input Enable bit (LUTCTRL.LUTEI) enables the corresponding action on input event. Writing a '0' to this bit disables the corresponding action on input event.

### Related Links

[31. EVSYS – Event System](#)

#### 41.6.4 Sleep Mode Operation

When using the GCLK\_CCL internal clocking, writing the Run In Standby bit in the Control register (CTRL.RUNSTDBY) to '1' will allow GCLK\_CCL to be enabled in Standby Sleep mode.

If CTRL.RUNSTDBY=0, the GCLK\_CCL will be disabled in Standby Sleep mode. If the Filter, Edge Detector or Sequential logic are enabled, the LUT output will be forced to zero in STANDBY mode. In all other cases, the TRUTH table decoder will continue operation and the LUT output will be refreshed accordingly.

### Related Links

[18. PM – Power Manager](#)

### 41.7 Register Summary

Offset	Name	Bit Pos.							
0x00	<b>CTRL</b>	7:0		RUNSTDBY					ENABLE SWRST
0x01	Reserved								
...									
0x03									
0x04	<b>SEQCTRL0</b>	7:0							SEQSEL[3:0]
0x05	<b>SEQCTRL1</b>	7:0							SEQSEL[3:0]
0x06	Reserved								
...									
0x07									
0x08	<b>LUTCTRL0</b>	7:0	EDGESEL			FILTSEL[1:0]			ENABLE
		15:8	INSELx[3:0]			INSELx[3:0]			
		23:16		LUTEO	LUTEI	INVEI	INSELx[3:0]		
		31:24	TRUTH[7:0]						
0x0C	<b>LUTCTRL1</b>	7:0	EDGESEL			FILTSEL[1:0]			ENABLE
		15:8	INSELx[3:0]			INSELx[3:0]			
		23:16		LUTEO	LUTEI	INVEI	INSELx[3:0]		
		31:24	TRUTH[7:0]						
0x10	<b>LUTCTRL2</b>	7:0	EDGESEL			FILTSEL[1:0]			ENABLE
		15:8	INSELx[3:0]			INSELx[3:0]			
		23:16		LUTEO	LUTEI	INVEI	INSELx[3:0]		
		31:24	TRUTH[7:0]						
0x14	<b>LUTCTRL3</b>	7:0	EDGESEL			FILTSEL[1:0]			ENABLE
		15:8	INSELx[3:0]			INSELx[3:0]			
		23:16		LUTEO	LUTEI	INVEI	INSELx[3:0]		
		31:24	TRUTH[7:0]						

### 41.8 Register Description

Registers can be 8, 16, or 32 bits wide. Atomic 8-, 16- and 32-bit accesses are supported. In addition, the 8-bit quarters and 16-bit halves of a 32-bit register, and the 8-bit halves of a 16-bit register can be accessed directly.

Some registers are optionally write-protected by the Peripheral Access Controller (PAC). Optional PAC write protection is denoted by the "PAC Write-Protection" property in each individual register description. For details, refer to [41.5.8 Register Access Protection](#).

Some registers are enable-protected, meaning they can only be written when the peripheral is disabled. Enable-protection is denoted by the "Enable-Protected" property in each individual register description.

### 41.8.1 Control

**Name:** CTRL  
**Offset:** 0x00  
**Reset:** 0x00  
**Property:** PAC Write-Protection

	7	6	5	4	3	2	1	0
		RUNSTDBY					ENABLE	SWRST
Access		R/W					R/W	W
Reset		0					0	0

#### Bit 6 – RUNSTDBY Run in Standby

This bit indicates if the GCLK\_CCL clock must be kept running in standby mode. The setting is ignored for configurations where the generic clock is not required. For details refer to [41.6.4 Sleep Mode Operation](#).



**Important:** This bit must be written before enabling the CCL.

Value	Description
0	Generic clock is not required in standby sleep mode.
1	Generic clock is required in standby sleep mode.

#### Bit 1 – ENABLE Enable

Value	Description
0	The peripheral is disabled.
1	The peripheral is enabled.

#### Bit 0 – SWRST Software Reset

Writing a '0' to this bit has no effect.

Writing a '1' to this bit resets all registers in the CCL to their initial state.

Value	Description
0	There is no reset operation ongoing.
1	The reset operation is ongoing.



# SAM D5x/E5x Family Data Sheet

## CCL – Configurable Custom Logic

### 41.8.2 Sequential Control x

**Name:** SEQCTRL  
**Offset:** 0x04 + n\*0x01 [n=0..1]  
**Reset:** 0x00  
**Property:** PAC Write-Protection

	7	6	5	4	3	2	1	0
					SEQSEL[3:0]			
Access					R/W	R/W	R/W	R/W
Reset					0	0	0	0

#### Bits 3:0 – SEQSEL[3:0] Sequential Selection

These bits select the sequential configuration:

#### Sequential Selection

Value	Name	Description
0x0	DISABLE	Sequential logic is disabled
0x1	DFF	D flip flop
0x2	JK	JK flip flop
0x3	LATCH	D latch
0x4	RS	RS latch
0x5 – 0xF		Reserved

# SAM D5x/E5x Family Data Sheet

## CCL – Configurable Custom Logic

### 41.8.3 LUT Control x

**Name:** LUTCTRL  
**Offset:** 0x08 + n\*0x04 [n=0..3]  
**Reset:** 0x00000000  
**Property:** PAC Write-Protection, Enable-protected

	Bit	31	30	29	28	27	26	25	24
		TRUTH[7:0]							
Access		R/W	R/W	R/W	R/W	R/W	R/W	R/W	R/W
Reset		0	0	0	0	0	0	0	0
	Bit	23	22	21	20	19	18	17	16
			LUTEO	LUTEI	INVEI	INSELx[3:0]			
Access			R/W	R/W	R/W	R/W	R/W	R/W	R/W
Reset			0	0	0	0	0	0	0
	Bit	15	14	13	12	11	10	9	8
		INSELx[3:0]				INSELx[3:0]			
Access		R/W	R/W	R/W	R/W	R/W	R/W	R/W	R/W
Reset		0	0	0	0	0	0	0	0
	Bit	7	6	5	4	3	2	1	0
		EDGESEL		FILTSEL[1:0]				ENABLE	
Access		R/W		R/W	R/W			R/W	
Reset		0		0	0			0	

#### Bits 31:24 – TRUTH[7:0] Truth Table

These bits define the value of truth logic as a function of inputs IN[2:0].

#### Bit 22 – LUTEO LUT Event Output Enable

Value	Description
0	LUT event output is disabled.
1	LUT event output is enabled.

#### Bit 21 – LUTEI LUT Event Input Enable

Value	Description
0	LUT incoming event is disabled.
1	LUT incoming event is enabled.

#### Bit 20 – INVEI Inverted Event Input Enable

Value	Description
0	Incoming event is not inverted.
1	Incoming event is inverted.

#### Bit 7 – EDGESEL Edge Selection

Value	Description
0	Edge detector is disabled.
1	Edge detector is enabled.

# SAM D5x/E5x Family Data Sheet

## CCL – Configurable Custom Logic

### Bits 5:4 – FILTSEL[1:0] Filter Selection

These bits select the LUT output filter options:

#### Filter Selection

Value	Name	Description
0x0	DISABLE	Filter disabled
0x1	SYNCH	Synchronizer enabled
0x2	FILTER	Filter enabled
0x3	-	Reserved

### Bit 1 – ENABLE LUT Enable

Value	Description
0	The LUT is disabled.
1	The LUT is enabled.

### Bits 19:16,15:12,11:8 – INSELx LUT Input x Source Selection

These bits select the LUT input x source:

Value	Name	Description
0x0	MASK	Masked input
0x1	FEEDBACK	Feedback input source
0x2	LINK	Linked LUT input source
0x3	EVENT	Event input source
0x4	IO	I/O pin input source
0x5	AC	AC input source
0x6	TC	TC input source
0x7	ALTTC	Alternative TC input source
0x8	TCC	TCC input source
0x9	SERCOM	SERCOM input source

## **42. AES – Advanced Encryption Standard**

### **42.1 Overview**

The Advanced Encryption Standard peripheral (AES) provides a means for symmetric-key encryption of 128-bit blocks, in compliance to NIST specifications.

A symmetric-key algorithm requires the same key for both encryption and decryption.

Different key sizes are supported. The key size determines the number of repetitions of transformation rounds that convert the input (called the "plaintext") into the final output ("ciphertext"). The number of rounds of repetition is as follows:

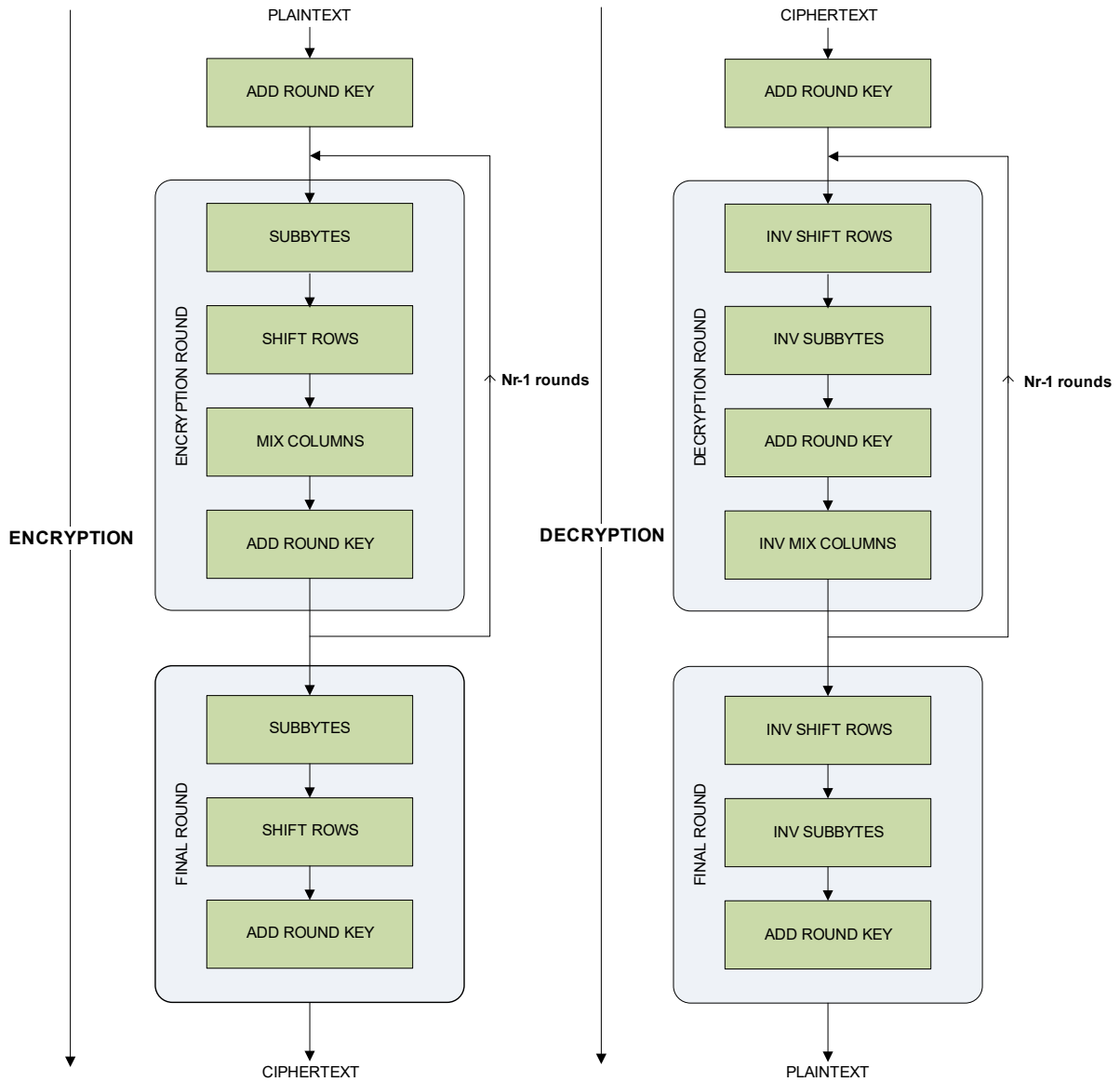
- 10 rounds of repetition for 128-bit keys
- 12 rounds of repetition for 192-bit keys
- 14 rounds of repetition for 256-bit keys

### **42.2 Features**

- Compliant with FIPS Publication 197, Advanced Encryption Standard (AES)
- 128/192/256 bit cryptographic key supported
- Encryption time of 57/67/77 cycles with 128-bit/192-bit/256-bit cryptographic key
- Five confidentiality modes of operation as recommended in NIST Special Publication 800-38A
- Electronic Code Book (ECB)
- Cipher Block Chaining (CBC)
- Cipher Feedback (CFB)
- Output Feedback (OFB)
- Counter (CTR)
- Supports Counter with CBC-MAC (CCM/CCM\*) mode for authenticated encryption
- 8, 16, 32, 64, 128-bit data sizes possible in CFB mode
- Optional (parameter) Galois Counter mode (GCM) encryption and authentication

**42.3 Block Diagram**

**Figure 42-1. AES Block Diagram**



### 42.4 Signal Description

Not applicable.

### 42.5 Product Dependencies

In order to use this AES module, other parts of the system must be configured correctly, as described below.

#### 42.5.1 I/O Lines

Not applicable.

#### 42.5.2 Power Management

The AES will continue to operate in Standby sleep mode, if it's source clock is running.

The AES interrupts can be used to wake up the device from Standby sleep mode. Refer to the Power Manager chapter for details on the different sleep modes.

AES is clocked only on the following conditions:

- When the DMA is enabled.
- Whenever there is an APB access for any read and write operation to the AES registers. (Not in Standby sleep mode.)
- When the AES is enabled & encryption/decryption is ongoing.

#### 42.5.3 Clocks

The AES bus clock (CLK\_AES\_APB) can be enabled and disabled in the Main Clock module, and the default state of CLK\_AES\_APB can be found in *Peripheral Clock Masking*. The module is fully clocked by CLK\_AES\_APB.

##### Related Links

[15.6.2.6 Peripheral Clock Masking](#)

#### 42.5.4 DMA

The AES has two DMA request lines; one for input data, and one for output data. They are both connected to the DMA Controller (DMAC). These DMA request triggers will be acknowledged by the DMAC ACK signals. Using the AES DMA requests requires the DMA Controller to be configured first. Refer to the device DMA documentation.

#### 42.5.5 Interrupts

The interrupt request line is connected to the interrupt controller. Using the AES interrupt requires the interrupt controller to be configured first. Refer to the Processor and Architecture chapter for details.

All the AES interrupts are synchronous wake-up sources. See *Sleep Mode Controller* for details.

##### Related Links

[18.6.3.3 Sleep Mode Controller](#)

#### 42.5.6 Events

Not applicable.

### 42.5.7 Debug Operation

When the CPU is halted in debug mode, the AES module continues normal operation. If the AES module is configured in a way that requires it to be periodically serviced by the CPU through interrupts or similar, improper operation or data loss may result during debugging. The AES module can be forced to halt operation during debugging.

### 42.5.8 Register Access Protection

All registers with write-access are optionally write-protected by the peripheral access controller (PAC), except the

following register:

- Interrupt Flag Register (INTFLAG)

Write-protection is denoted by the Write-Protected property in the register description.

Write-protection does not apply to accesses through an external debugger. Refer to *PAC - Peripheral Access Controller* chapter for details.

#### Related Links

[27. PAC - Peripheral Access Controller](#)

### 42.5.9 Analog Connections

Not applicable.

## 42.6 Functional Description

### 42.6.1 Principle of Operation

The following is a high level description of the algorithm. These are the steps:

- KeyExpansion: Round keys are derived from the cipher key using Rijndael's key schedule.
- InitialRound:
  - AddRoundKey: Each byte of the state is combined with the round key using bitwise XOR.
- Rounds:
  - SubBytes: A non-linear substitution step where each byte is replaced with another according to a lookup table.
  - ShiftRows: A transposition step where each row of the state is shifted cyclically a certain number of steps.
  - MixColumns: A mixing operation which operates on the columns of the state, combining the four bytes in each column.
  - AddRoundKey
- Final Round (no MixColumns):
  - SubBytes
  - ShiftRows
  - AddRoundKey

The relationship between the module's clock frequency and throughput (in bytes per second) is given by:

Clock Frequency = (Throughput/2) x (Nr+1) for 2 byte parallel processing

Clock Frequency = (Throughput/4) x (Nr+1) for 4 byte parallel processing

where  $N_r$  is the number of rounds, depending on the key length.

### 42.6.2 Basic Operation

#### 42.6.2.1 Initialization

The following register is enable-protected:

- Control A (CTRLA)

Enable-protection is denoted by the Enable-Protected property in the register description.

#### 42.6.2.2 Enabling, Disabling, and Resetting

The AES module is enabled by writing a one to the Enable bit in the Control A register (CTRLA.ENABLE). The module is disabled by writing a zero to CTRLA.ENABLE. The module is reset by writing a one to the Software Reset bit in the Control A register (CTRLA.SWRST).

#### 42.6.2.3 Basic Programming

The CIPHER bit in the Control A Register (CTRLA.CIPHER) allows selection between the encryption and the decryption processes. The AES is capable of using cryptographic keys of 128/192/256 bits to encrypt and decrypt data in blocks of 128 bits. The Key Size (128/192/256) can be programmed in the KEYSIZE field in the Control A Register (CTRLA.KEYSIZE). This 128-bit/192-bit/256-bit key is defined in the Key Word Registers (KEYWORD). By setting the XORKEY bit of CTRLA register, keyword can be updated with the resulting XOR value of user keyword and previous keyword content.

The input data for processing is written to a data buffer consisting of four 32-bit registers through the Data register address. The data buffer register (note that input and output data shares the same data buffer register) that is written to when the next write is performed is indicated by the Data Pointer in the Data Buffer Pointer (DATABUFPTR) register. This field is incremented by one or wrapped by hardware when a write to the DATA register address is performed. This field can also be programmed, allowing the user direct control over which input buffer register to write to. Note that when AES module is in the CFB operation mode with the data segment size less than 128 bits, the input data must be written to the first (DATABUFPTR = 0) and/or second (DATABUFPTR = 1) input buffer registers (see [Table 42-1](#)).

The input to the encryption processes of the CBC, CFB and OFB modes includes, in addition to the plaintext, a 128-bit data block called the Initialization Vector (IV), which must be set in the Initialization Vector Registers (INTVECT). Additionally, the GCM mode 128-bit authentication data needs to be programmed. The Initialization Vector is used in the initial step in the encryption of a message and in the corresponding decryption of the message. The Initialization Vector Registers are also used by the Counter mode to set the counter value.

It is necessary to notify AES module whenever the next data block it is going to process is the beginning of a new message. This is done by writing a one to the New Message bit in the Control B register (CTRLB.NEWMMSG).

The AES modes of operation are selected by setting the AESMODE field in the Control A Register (CTRLA.AESMODE). In Cipher Feedback Mode (CFB), five data sizes are possible (8, 16, 32, 64 or 128 bits), configurable by means of the CFBS field in the Control A Register (CTRLA.CFBS). In Counter mode, the size of the block counter embedded in the module is 16 bits. Therefore, there is a rollover after processing 1 megabyte of data. The data pre-processing, post-processing and data chaining for the concerned modes are automatically performed by the module.

When data processing has completed, the Encryption Complete bit in the Interrupt Flag register (INTFLAG.ENCCMP) is set by hardware (which triggers an interrupt request if the corresponding interrupt is enabled). The processed output data is read out through the Output Data register (DATA) address from the data buffer consisting of four 32-bit registers. The data buffer register that is read from when the next



# SAM D5x/E5x Family Data Sheet

## AES – Advanced Encryption Standard

read is performed is indicated by the Data Pointer field in the Data Buffer Pointer register (DATABUFPTR). This field is incremented by one or wrapped by hardware when a read from the DATA register address is performed. This field can also be programmed, giving the user direct control over which output buffer register to read from. Note that when AES module is in the CFB operation mode with the data segment size less than 128 bits, the output data must be read from the first (DATABUFPTR = 0) and/or second (DATABUFPTR = 1) output buffer registers (see [Table 42-1](#)). The Encryption Complete bit (INTFLAG.ENCCMP) is cleared by hardware after the processed data has been read from the relevant output buffer registers.

**Table 42-1. Relevant Input/Output Data Registers for Different Confidentiality Modes**

Confidentiality Mode	Relevant Input / Output Data Registers
ECB	All
CBC	All
OFB	All
128-bit CFB	All
64-bit CFB	First and Second
32-bit CFB	First
16-bit CFB	First
8-bit CFB	First
CTR	All

#### 42.6.2.4 Start Modes

The Start mode field in the Control A Register (CTRLA.STARTMODE) allows the selection of encryption start mode.

##### 1. Manual Start Mode

In the Manual Start Mode the sequence is as follows:

- 1.1. Write the 128/192/256 bit key in the Key Register (KEYWORD)
- 1.2. Write the initialization vector or counter in the Initialization Vector Register (INTVECT). The initialization vector concerns all modes except ECB
- 1.3. Enable interrupts in Interrupt Enable Set Register (INTENSET), depending on whether an interrupt is required or not at the end of processing.
- 1.4. Write the data to be encrypted or decrypted in the Data Registers (DATA).
- 1.5. Set the START bit in Control B Register (CTRLB.START) to begin the encryption or the decryption process.
- 1.6. When the processing completes, the Encryption Complete bit in the Interrupt Flag Register (INTFLAG.ENCCMP) raises. If Encryption Complete interrupt has been enabled, the interrupt line of the AES is activated.
- 1.7. When the software reads one of the Output Data Registers (DATA), INTFLAG.ENCCMP bit is automatically cleared.

##### 2. Auto start Mode

The Auto Start Mode is similar to the manual one, except in this mode, as soon as the correct number of input data registers is written, processing is automatically started without setting the START bit in the Control B Register. DMA operation uses this mode.

### 3. Last Output Data Mode (LOD)

This mode is used to generate message authentication code (MAC) on data in CCM mode of operation. The CCM mode combines counter mode for encryption and CBC-MAC generation for authentication.

When LOD is disabled in CCM mode then counter mode of encryption is performed on the input data block.

When LOD is enabled in CCM mode then CBC-MAC generation is performed. Zero block is used as the initialization vector by the hardware. Also software read from the Output Data Register (DATA) is not required to clear the ENCCMP flag. The ENCCMP flag is automatically cleared by writing into the Input Data Register (DATA). This allows retrieval of only the last data in several encryption/decryption processes. No output data register reads are necessary between each block of encryption/decryption process.

Note that assembling message depending on the security level identifier in CCM\* has to be done in software.

#### 42.6.2.5 Computation of last $N_k$ words of expanded key

The AES algorithm takes the cryptographic key provided by the user and performs a Key Expansion routine to generate an expanded key. The expanded key contains a total of  $4(N_r + 1)$  32-bit words, where the first  $N_k$  (4/6/8 for a 128-/192-/256-bit key) words are the user-provided key. For data encryption, the expanded key is used in the forward direction, i.e., the first four words are used in the initial round of data processing, the second four words in the first round, the third four words in the second round, and so on. On the other hand, for data decryption, the expanded key is used in the reverse direction, i.e., the last four words are used in the initial round of data processing, the last second four words in the first round, the last third four words in the second round, and so on.

To reduce gate count, the AES module does not generate and store the entire expanded key prior to data processing. Instead, it computes on-the-fly the round key (four 32-bit words) required for the current round of data processing. In general, the round key for the current round of data processing can be computed from the  $N_k$  words of the expanded key generated in the previous rounds. When AES module is operating in the encryption mode, the round key for the initial round of data processing is simply the user-provided key written to the KEY registers. On the other hand, when AES module is operating in the decryption mode, the round key for the initial round of data processing is the last four words of the expanded key, which is not available unless AES module has performed at least one encryption process prior to operating in the decryption mode.

In general, the last  $N_k$  words of the expanded key must be available before decryption can start. If desired, AES module can be instructed to compute the last  $N_k$  words of the expanded key in advance by writing a one to the Key Generate (KEYGEN) bit in the CTRLA register (CTRLA.KEYGEN). The computation takes  $N_r$  clock cycles. Alternatively, the last  $N_k$  words of the expanded key can be automatically computed by AES module when a decryption process is initiated if they have not been computed in advance or have become invalid. Note that this will introduce a latency of  $N_r$  clock cycles to the first decryption process.

#### 42.6.2.6 Hardware Countermeasures against Differential Power Analysis Attacks

The AES module features four types of hardware countermeasures that are useful for protecting data against differential power analysis attacks:

- Type 1: Randomly add one cycle to data processing
- Type 2: Randomly add one cycle to data processing (other version)

# SAM D5x/E5x Family Data Sheet

## AES – Advanced Encryption Standard

---

- Type 3: Add a random number of clock cycles to data processing, subject to a maximum of 11/13/15 clock cycles for key sizes of 128/192/256 bits
- Type 4: Add random spurious power consumption during data processing

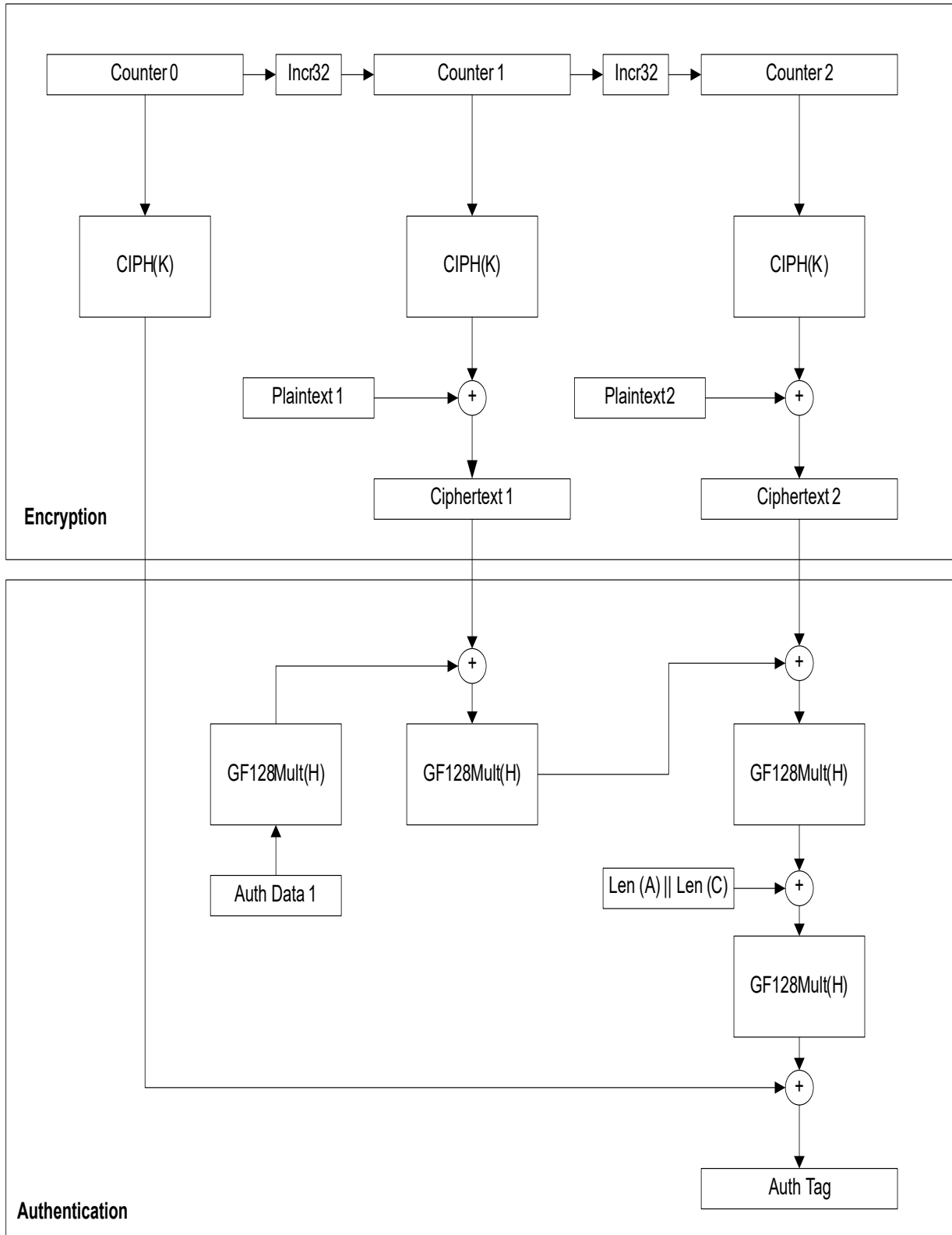
By default, all countermeasures are enabled. One or more of the countermeasures can be disabled by programming the Countermeasure Type field in the Control A (CTRLA.CTYPE) register. The countermeasures use random numbers generated by a deterministic random number generator embedded in AES module. The seed for the random number generator is written to the RANDSEED register. Note also that a new seed must be written after a change in the keysize. Note that enabling countermeasures reduces AES module's throughput. In short, the throughput is highest with all the countermeasures disabled. On the other hand, with all of the countermeasures enabled, the best protection is achieved but the throughput is worst.

### 42.6.3 Galois Counter Mode (GCM)

GCM is comprised of the AES engine in CTR mode along with a universal hash function (GHASH engine) that is defined over a binary Galois field to produce a message authentication tag. The GHASH engine processes data packets after the AES operation. GCM provides assurance of the confidentiality of data through the AES Counter mode of operation for encryption. Authenticity of the confidential data is assured through the GHASH engine. Refer to the NIST Special Publication 800-38D Recommendation for more complete information.

# SAM D5x/E5x Family Data Sheet

## AES – Advanced Encryption Standard



### 42.6.3.1 GCM Operation

#### 42.6.3.1.1 Hashkey Generation

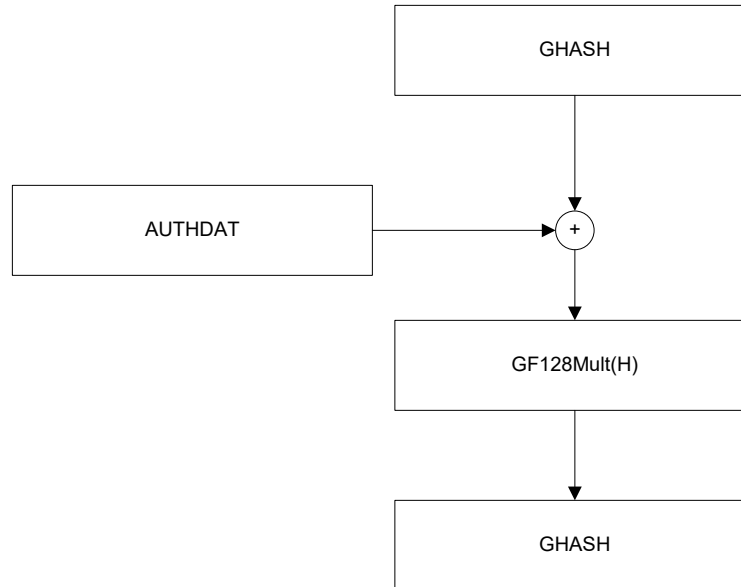
- Configure CTRLA register as follows:
  1. CTRLA.STARTMODE as Manual (Auto for DMAC)
  2. CTRLA.CIPHER as Encryption
  3. CTRLA.KEYSIZE as per the key used
  4. CTRLA.AESMODE as ECB
  5. CTRLA.CTYPE as per the countermeasures required.
- Set CTRLA.ENABLE
- Write zero to CIPLN reg.
- Write the key in KEYWORD register
- Write the zeros to DATA reg
- Set CTRLB.Start.
- Wait for INTFLAG.ENCCMP to be set
- AES Hardware generates Hash Subkey in HASHKEY register.

#### 42.6.3.1.2 Authentication Header Processing

- Configure CTRLA register as follows:
  1. CTRLA.STARTMODE as Manual
  2. CTRLA.CIPHER as Encryption
  3. CTRLA.KEYSIZE as per the key used
  4. CTRLA.AESMODE as GCM
  5. CTRLA.CTYPE as per the countermeasures required.
- Set CTRLA.ENABLE
- Write the key in KEYWORD register
- Set CTRLB.GFMUL
- Write the Authdata to DATA reg
- Set CTRLB.START as 1
- Wait for INTFLAG.GFMCMP to be set.
- AES Hardware generates output in GHASH register
- Continue steps 4 to 7 for remaining Authentication Header.  
Note: If the Auth data is less than 128 bit, it has to be padded with zero to make it 128 bit aligned.

# SAM D5x/E5x Family Data Sheet

## AES – Advanced Encryption Standard



### 42.6.3.1.3 Plain text Processing

- Set CTRLB.NEWMSG for the new set of plain text processing.
- Load CIPLN reg.
- Load (J0+1) in INTVECT register.
- As described in NIST documentation  $J_0 = IV \parallel 0 \ 31 \parallel 1$  when  $\text{len}(IV)=96$  and  $J_0 = \text{GHASH}_H(IV \parallel 0 \ s \ +64 \parallel [\text{len}(IV)] \ 64)$  (s is the minimum number of zeroes that should be padded with the Initialization Vector to make it a multiple of 128) if  $\text{len}(IV) \neq 96$ .
- Load plain text in DATA register.
- Set CTRLB.START as 1.
- Wait for INTFLAG.ENCCMP to be set.
- AES Hardware generates output in DATA register.
- Intermediate GHASH is stored in GHASH register and Cipher Text available in DATA register.
- Continue 3 to 6 till the input of plain text to get the cipher text and the Hash keys.
- At the last input, set CTRLB.EOM.
- Write last in-data to DATA reg.
- Set CTRLB.START as 1.
- Wait for INTFLAG.ENCCMP to be set.
- AES Hardware generates output in DATA register and final Hash key in GHASH register.
- Load  $[\text{LEN}(A)]64 \parallel [\text{LEN}(C)]64$  in DATA register and set CTRLB.GFMUL and CTRLB.START as 1.
- Wait for INTFLAG.GFMCMP to be set.
- AES Hardware generates final GHASH value in GHASH register.

### 42.6.3.1.4 Plain text processing with DMAC

- Set CTRLB.NEWMSG for the new set of plain text processing.
- Load CIPLN reg.
- Load (J0+1) in INTVECT register.
- Load plain text in DATA register.
- Wait for INTFLAG.ENCCMP to be set.

# SAM D5x/E5x Family Data Sheet

## AES – Advanced Encryption Standard

---

- AES Hardware generates output in DATA register.
- Intermediate GHASH is stored in GHASH register and Cipher Text available in DATA register.
- Continue 3 to 5 till the input of plain text to get the cipher text and the Hash keys.
- At the last input, set CTRLB.EOM.
- Write last in-data to DATA reg.
- Wait for INTFLAG.ENCCMP to be set.
- AES Hardware generates output in DATA register and final Hash key in GHASH register.
- Load  $[\text{LEN(A)}]64||[\text{LEN(C)}]64$  in DATA register and set CTRLB.GFMUL and CTRLB.START as 1.
- Wait for INTFLAG.GFMCMP to be set.
- AES Hardware generates final GHASH value in GHASH register.

### 42.6.3.1.5 Tag Generation

- Configure CTRLA
  1. Set CTRLA.ENABLE to 0
  2. Set CTRLA.AESMODE as CTR
  3. Set CTRLA.ENABLE to 1
- Load J0 value to INITVECTV reg.
- Load GHASH value to DATA reg.
- Set CTRLB.NEWMSG and CTRLB.START to start the Counter mode operation.
- Wait for INTFLAG.ENCCMP to be set.
- AES Hardware generates the GCM Tag output in DATA register.

### 42.6.4 Synchronization

Not applicable.

# SAM D5x/E5x Family Data Sheet

## AES – Advanced Encryption Standard

### 42.7 Register Summary

Offset	Name	Bit Pos.									
0x00	CTRLA	7:0	CFBS[2:0]		AESMODE[2:0]			ENABLE	SWRST		
		15:8	XORKEY	KEYGEN	LOD	STARTMODE	CIPHER	KEYSIZE[1:0]			
		23:16	CTYPE[3:0]								
		31:24									
0x04	CTRLB	7:0				GFMUL	EOM	NEWMSG	START		
0x05	INTENCLR	7:0						GFMCMP	ENCCMP		
0x06	INTENSET	7:0						GFMCMP	ENCCMP		
0x07	INTFLAG	7:0						GFMCMP	ENCCMP		
0x08	DATABUFPTR	7:0						INDATAPTR[1:0]			
0x09	DBGCTRL	7:0							DBGRUN		
0x0A ... 0x0B	Reserved										
0C	KEYWORD0	7:0	KEYWORD[7:0]								
		15:8	KEYWORD[15:8]								
		23:16	KEYWORD[23:16]								
		31:24	KEYWORD[31:24]								
10	KEYWORD1	7:0	KEYWORD[7:0]								
		15:8	KEYWORD[15:8]								
		23:16	KEYWORD[23:16]								
		31:24	KEYWORD[31:24]								
14	KEYWORD2	7:0	KEYWORD[7:0]								
		15:8	KEYWORD[15:8]								
		23:16	KEYWORD[23:16]								
		31:24	KEYWORD[31:24]								
18	KEYWORD3	7:0	KEYWORD[7:0]								
		15:8	KEYWORD[15:8]								
		23:16	KEYWORD[23:16]								
		31:24	KEYWORD[31:24]								
1C	KEYWORD4	7:0	KEYWORD[7:0]								
		15:8	KEYWORD[15:8]								
		23:16	KEYWORD[23:16]								
		31:24	KEYWORD[31:24]								
20	KEYWORD5	7:0	KEYWORD[7:0]								
		15:8	KEYWORD[15:8]								
		23:16	KEYWORD[23:16]								
		31:24	KEYWORD[31:24]								
24	KEYWORD6	7:0	KEYWORD[7:0]								
		15:8	KEYWORD[15:8]								
		23:16	KEYWORD[23:16]								
		31:24	KEYWORD[31:24]								



# SAM D5x/E5x Family Data Sheet

## AES – Advanced Encryption Standard

.....continued									
Offset	Name	Bit Pos.							
28	KEYWORD7	7:0	KEYWORD[7:0]						
		15:8	KEYWORD[15:8]						
		23:16	KEYWORD[23:16]						
		31:24	KEYWORD[31:24]						
0x2C ... 0x37	Reserved								
0x38	DATA	7:0	DATA[7:0]						
		15:8	DATA[15:8]						
		23:16	DATA[23:16]						
		31:24	DATA[31:24]						
3C	INTVECTV0	7:0	INTVECTV[7:0]						
		15:8	INTVECTV[15:8]						
		23:16	INTVECTV[23:16]						
		31:24	INTVECTV[31:24]						
40	INTVECTV1	7:0	INTVECTV[7:0]						
		15:8	INTVECTV[15:8]						
		23:16	INTVECTV[23:16]						
		31:24	INTVECTV[31:24]						
44	INTVECTV2	7:0	INTVECTV[7:0]						
		15:8	INTVECTV[15:8]						
		23:16	INTVECTV[23:16]						
		31:24	INTVECTV[31:24]						
48	INTVECTV3	7:0	INTVECTV[7:0]						
		15:8	INTVECTV[15:8]						
		23:16	INTVECTV[23:16]						
		31:24	INTVECTV[31:24]						
0x4C ... 0x5B	Reserved								
0x5C	HASHKEY0	7:0	HASHKEY[7:0]						
		15:8	HASHKEY[15:8]						
		23:16	HASHKEY[23:16]						
		31:24	HASHKEY[31:24]						
0x60	HASHKEY1	7:0	HASHKEY[7:0]						
		15:8	HASHKEY[15:8]						
		23:16	HASHKEY[23:16]						
		31:24	HASHKEY[31:24]						
0x64	HASHKEY2	7:0	HASHKEY[7:0]						
		15:8	HASHKEY[15:8]						
		23:16	HASHKEY[23:16]						
		31:24	HASHKEY[31:24]						

# SAM D5x/E5x Family Data Sheet

## AES – Advanced Encryption Standard

.....continued									
Offset	Name	Bit Pos.							
0x68	HASHKEY3	7:0	HASHKEY[7:0]						
		15:8	HASHKEY[15:8]						
		23:16	HASHKEY[23:16]						
		31:24	HASHKEY[31:24]						
0x6C	GHASH0	7:0	GHASH[7:0]						
		15:8	GHASH[15:8]						
		23:16	GHASH[23:16]						
		31:24	GHASH[31:24]						
0x70	GHASH1	7:0	GHASH[7:0]						
		15:8	GHASH[15:8]						
		23:16	GHASH[23:16]						
		31:24	GHASH[31:24]						
0x74	GHASH2	7:0	GHASH[7:0]						
		15:8	GHASH[15:8]						
		23:16	GHASH[23:16]						
		31:24	GHASH[31:24]						
0x78	GHASH3	7:0	GHASH[7:0]						
		15:8	GHASH[15:8]						
		23:16	GHASH[23:16]						
		31:24	GHASH[31:24]						
0x7C ... 0x7F	Reserved								
80	CIPLN	7:0	CIPLN[7:0]						
		15:8	CIPLN[15:8]						
		23:16	CIPLN[23:16]						
		31:24	CIPLN[31:24]						
0x84	RANDSEED	7:0	RANDSEED[7:0]						
		15:8	RANDSEED[15:8]						
		23:16	RANDSEED[23:16]						
		31:24	RANDSEED[31:24]						

### 42.8 Register Description

Registers can be 8, 16, or 32 bits wide. Atomic 8-, 16- and 32-bit accesses are supported. In addition, the 8-bit quarters and 16-bit halves of a 32-bit register, and the 8-bit halves of a 16-bit register can be accessed directly.

Some registers are optionally write-protected by the Peripheral Access Controller (PAC). Optional PAC write protection is denoted by the "PAC Write-Protection" property in each individual register description. For details, refer to [42.5.8 Register Access Protection](#).

Some registers are enable-protected, meaning they can only be written when the peripheral is disabled. Enable-protection is denoted by the "Enable-Protected" property in each individual register description.

# SAM D5x/E5x Family Data Sheet

## AES – Advanced Encryption Standard

### 42.8.1 Control A

**Name:** CTRLA  
**Offset:** 0x00  
**Reset:** 0x00000000  
**Property:** PAC Write-Protection, Enable-protected

	Bit	31	30	29	28	27	26	25	24
		[Greyed out bits 31-24]							
Access									
Reset									
	Bit	23	22	21	20	19	18	17	16
		[Greyed out bits 23-20] CTYPE[3:0]							
Access						R/W	R/W	R/W	R/W
Reset						0	0	0	0
	Bit	15	14	13	12	11	10	9	8
		[Greyed out bit 15]	XORKEY	KEYGEN	LOD	STARTMODE	CIPHER	KEYSIZE[1:0]	
Access			R/W	R/W	R/W	R/W	R/W	R/W	R/W
Reset			0	0	0	0	0	0	0
	Bit	7	6	5	4	3	2	1	0
		CFBS[2:0]			AESMODE[2:0]			ENABLE	SWRST
Access		R/W	R/W	R/W	R/W	R/W	R/W	R/W	R/W
Reset		0	0	0	0	0	0	0	0

#### Bits 19:16 – CTYPE[3:0] Counter Measure Type

Value	Name	Description
XXX0	CTYPE1 disabled	Countermeasure1 disabled
XXX1	CTYPE1 enabled	Countermeasure1 enabled
XX0X	CTYPE2 disabled	Countermeasure2 disabled
XX1X	CTYPE2 enabled	Countermeasure2 enabled
X0XX	CTYPE3 disabled	Countermeasure3 disabled
X1XX	CTYPE3 enabled	Countermeasure3 enabled
0XXX	CTYPE4 disabled	Countermeasure4 disabled
1XXX	CTYPE4 enabled	Countermeasure4 enabled

#### Bit 14 – XORKEY XOR Key Operation

Value	Description
0	No effect
1	The user keyword gets XORed with the previous keyword register content.

#### Bit 13 – KEYGEN Last Key Generation

Value	Description
0	No effect
1	Start Computation of the last NK words of the expanded key

# SAM D5x/E5x Family Data Sheet

## AES – Advanced Encryption Standard

### Bit 12 – LOD Last Output Data Mode

Value	Description
0	No effect
1	Start encryption in Last Output Data mode

### Bit 11 – STARTMODE Start Mode Select

Value	Name	Description
0	Manual Mode	Start Encryption / Decryption in Manual mode
1	Auto Mode	Start Encryption / Decryption in Auto mode

### Bit 10 – CIPHER Cipher Mode Select

Value	Description
0	Decryption
1	Encryption

### Bits 9:8 – KEYSIZE[1:0] Encryption Key Size

Value	Name	Description
0	128-bit Key	128-bit Key for Encryption / Decryption
1	192-bit Key	192-bit Key for Encryption / Decryption
2	256-bit Key	256-bit Key for Encryption / Decryption
3	Reserved	Reserved

### Bits 7:5 – CFBS[2:0] Cipher Feedback Block Size

Value	Name	Description
0	128-bit data block	128-bit Input data block for Encryption/Decryption in Cipher Feedback mode
1	64-bit data block	64-bit Input data block for Encryption/Decryption in Cipher Feedback mode
2	32-bit data block	32-bit Input data block for Encryption/Decryption in Cipher Feedback mode
3	16-bit data block	16-bit Input data block for Encryption/Decryption in Cipher Feedback mode
4	8-bit data block	8-bit Input data block for Encryption/Decryption in Cipher Feedback mode
5-7	Reserved	Reserved

### Bits 4:2 – AESMODE[2:0] AES Modes of Operation

Value	Name	Description
0	ECB	Electronic code book mode
1	CBC	Cipher block chaining mode
2	OFB	Output feedback mode
3	CFB	Cipher feedback mode
4	Counter	Counter mode
5	CCM	CCM mode
6	GCM	Galois counter mode
7	Reserved	Reserved

### Bit 1 – ENABLE Enable

Value	Description
0	The peripheral is disabled

# SAM D5x/E5x Family Data Sheet

## AES – Advanced Encryption Standard

---

---

Value	Description
1	The peripheral is enabled

### Bit 0 – SWRST Software Reset

Writing a '0' to this bit has no effect.

Writing a '1' to this bit resets all registers in the AES module to their initial state, and the module will be disabled.

Writing a '1' to SWRST will always take precedence, meaning that all other writes in the same write operation will be discarded.

Value	Description
0	There is no reset operation ongoing
1	The reset operation is ongoing

# SAM D5x/E5x Family Data Sheet

## AES – Advanced Encryption Standard

### 42.8.2 Control B

**Name:** CTRLB  
**Offset:** 0x04  
**Reset:** 0x00  
**Property:** PAC Write-Protection

	7	6	5	4	3	2	1	0
					GFMUL	EOM	NEWMSG	START
Access					R/W	R/W	R/W	R/W
Reset					0	0	0	0

**Bit 3 – GFMUL** GF Multiplication  
 This bit is applicable only to GCM mode.

Value	Description
0	No action
1	Setting this bit calculates GF multiplication with data buffer content and hashkey register content.

**Bit 2 – EOM** End of Message  
 This bit is applicable only to GCM mode.

Value	Description
0	No action
1	Setting this bit generates final GHASH value for the message.

**Bit 1 – NEWMSG** New Message  
 This bit is used in cipher block chaining (CBC), cipher feedback (CFB) and output feedback (OFB), counter (CTR) modes to indicate the hardware to use Initialization vector for encrypting the first block of message.

Value	Description
0	No action
1	Setting this bit indicates start of new message to the module.

**Bit 0 – START** Start Encryption/Decryption

Value	Description
0	No action
1	Start encryption / decryption in manual mode.

# SAM D5x/E5x Family Data Sheet

## AES – Advanced Encryption Standard

### 42.8.3 Interrupt Enable Clear

**Name:** INTENCLR  
**Offset:** 0x05  
**Reset:** 0x00  
**Property:** PAC Write-Protection

This register allows the user to disable an interrupt without doing a read-modify-write operation. Changes in this register will also be reflected in the Interrupt Enable Set (*INTENSET*) register.

	7	6	5	4	3	2	1	0
							GFMCMP	ENCCMP
Access							R/W	R/W
Reset							0	0

**Bit 1 – GFMCMP** GF Multiplication Complete Interrupt Enable

Writing a '0' to this bit has no effect.

Writing a '1' to this bit will clear the GF Multiplication Complete Interrupt Enable bit, which disables the GF Multiplication Complete interrupt.

Value	Description
0	The GF Multiplication Complete interrupt is disabled.
1	The GF Multiplication Complete interrupt is enabled.

**Bit 0 – ENCCMP** Encryption Complete Interrupt Enable

Writing a '0' to this bit has no effect.

Writing a '1' to this bit will clear the Encryption Complete Interrupt Enable bit, which disables the Encryption Complete interrupt.

Value	Description
0	The Encryption Complete interrupt is disabled.
1	The Encryption Complete interrupt is enabled.

# SAM D5x/E5x Family Data Sheet

## AES – Advanced Encryption Standard

### 42.8.4 Interrupt Enable Set

**Name:** INTENSET  
**Offset:** 0x06  
**Reset:** 0x00  
**Property:** PAC Write-Protection

This register allows the user to enable an interrupt without doing a read-modify-write operation. Changes in this register will also be reflected in the Interrupt Enable Clear (`INTENCLR`) register.

	7	6	5	4	3	2	1	0
							GFMCMP	ENCCMP
Access							R/W	R/W
Reset							0	0

**Bit 1 – GFMCMP** GF Multiplication Complete Interrupt Enable

Writing a '0' to this bit has no effect. Writing a '1' to this bit will clear the GF Multiplication Complete Interrupt Enable bit, which enables the GF Multiplication Complete interrupt.

Value	Description
0	The GF Multiplication Complete interrupt is disabled.
1	The GF Multiplication Complete interrupt is enabled.

**Bit 0 – ENCCMP** Encryption Complete Interrupt Enable

Writing a '0' to this bit has no effect. Writing a '1' to this bit will clear the Encryption Complete Interrupt Enable bit, which enables the Encryption Complete interrupt.

Value	Description
0	The Encryption Complete interrupt is disabled.
1	The Encryption Complete interrupt is enabled.



# SAM D5x/E5x Family Data Sheet

## AES – Advanced Encryption Standard

### 42.8.5 Interrupt Flag Status and Clear

**Name:** INTFLAG  
**Offset:** 0x07  
**Reset:** 0x00

Bit	7	6	5	4	3	2	1	0
							GFMCMP	ENCCMP
Access							R/W	R/W
Reset							0	0

#### Bit 1 – GFMCMP GF Multiplication Complete

This flag is cleared by writing a '1' to it.

This flag is set when GHASH value is available on the Galois Hash Registers (GHASH<sub>x</sub>) in GCM mode.

Writing a '0' to this bit has no effect.

This flag is also automatically cleared in the following cases.

1. Manual encryption/decryption occurs (START in CTRLB register).
2. Reading from the GHASH<sub>x</sub> register.

#### Bit 0 – ENCCMP Encryption Complete

This flag is cleared by writing a '1' to it.

This flag is set when encryption/decryption is complete and valid data is available on the Data Register.

Writing a '0' to this bit has no effect.

This flag is also automatically cleared in the following cases:

1. Manual encryption/decryption occurs (START in CTRLA register). (This feature is needed only if we do not support double buffering of DATA registers).
2. Reading from the data register (DATA<sub>x</sub>) when LOD = 0.
3. Writing into the data register (DATA<sub>x</sub>) when LOD = 1.
4. Reading from the Hash Key register (HASHKEY<sub>x</sub>).

# SAM D5x/E5x Family Data Sheet

## AES – Advanced Encryption Standard

### 42.8.6 Data Buffer Pointer

**Name:** DATABUFPTR  
**Offset:** 0x08  
**Reset:** 0x00  
**Property:** PAC Write-Protection

Bit	7	6	5	4	3	2	1	0
							INDATAPTR[1:0]	
Access							R/W	R/W
Reset							0	0

#### **Bits 1:0 – INDATAPTR[1:0] Input Data Pointer**

Writing to this field changes the value of the input data pointer, which determines which of the four data registers is written to/read from when the next write/read to the `DATA` register address is performed.

# SAM D5x/E5x Family Data Sheet

## AES – Advanced Encryption Standard

### 42.8.7 Debug

**Name:** DBGCTRL  
**Offset:** 0x09  
**Reset:** 0x00  
**Property:** PAC Write-Protection

Bit	7	6	5	4	3	2	1	0
								DBGRUN
Access								W
Reset								0

#### Bit 0 – DBGRUN Debug Run

Writing a '0' to this bit causes the AES to halt during debug mode.

Writing a '1' to this bit allows the AES to continue normal operation during debug mode. This bit can only be changed while the AES is disabled.

# SAM D5x/E5x Family Data Sheet

## AES – Advanced Encryption Standard

### 42.8.8 Keyword

**Name:** KEYWORD  
**Offset:** 0x0C + n\*0x04 [n=0..7]  
**Reset:** 0x00000000  
**Property:** PAC Write-Protection

	Bit	31	30	29	28	27	26	25	24
		KEYWORD[31:24]							
Access		W	W	W	W	W	W	W	W
Reset		0	0	0	0	0	0	0	0
	Bit	23	22	21	20	19	18	17	16
		KEYWORD[23:16]							
Access		W	W	W	W	W	W	W	W
Reset		0	0	0	0	0	0	0	0
	Bit	15	14	13	12	11	10	9	8
		KEYWORD[15:8]							
Access		W	W	W	W	W	W	W	W
Reset		0	0	0	0	0	0	0	0
	Bit	7	6	5	4	3	2	1	0
		KEYWORD[7:0]							
Access		W	W	W	W	W	W	W	W
Reset		0	0	0	0	0	0	0	0

#### Bits 31:0 – KEYWORD[31:0] Key Word Value

The four/six/eight 32-bit Key Word registers set the 128-bit/192-bit/256-bit cryptographic key used for encryption/decryption. KEYWORD0 .KEYWORD corresponds to the first word of the key and KEYWORD3/KEYWORD5/KEYWORD7 .KEYWORD to the last one.

**Note:** By setting the XORKEY bit of CTRLA register, keyword will update with the resulting XOR value of user keyword and previous keyword content.

# SAM D5x/E5x Family Data Sheet

## AES – Advanced Encryption Standard

### 42.8.9 Data

**Name:** DATA  
**Offset:** 0x38  
**Reset:** 0x00000000

	Bit	31	30	29	28	27	26	25	24
		DATA[31:24]							
Access		R/W	R/W	R/W	R/W	R/W	R/W	R/W	R/W
Reset		0	0	0	0	0	0	0	0
	Bit	23	22	21	20	19	18	17	16
		DATA[23:16]							
Access		R/W	R/W	R/W	R/W	R/W	R/W	R/W	R/W
Reset		0	0	0	0	0	0	0	0
	Bit	15	14	13	12	11	10	9	8
		DATA[15:8]							
Access		R/W	R/W	R/W	R/W	R/W	R/W	R/W	R/W
Reset		0	0	0	0	0	0	0	0
	Bit	7	6	5	4	3	2	1	0
		DATA[7:0]							
Access		R/W	R/W	R/W	R/W	R/W	R/W	R/W	R/W
Reset		0	0	0	0	0	0	0	0

#### Bits 31:0 – DATA[31:0] Data Value

A write to or read from this register corresponds to a write to or read from one of the four data registers. The four 32-bit Data registers set the 128-bit data block used for encryption/decryption. The data register that is written to or read from is given by the `DATABUFPTR.DATPTR` field.

**Note:** Both input and output shares the same data buffer. Reading DATA register will return 0's when AES is performing encryption or decryption operation.

# SAM D5x/E5x Family Data Sheet

## AES – Advanced Encryption Standard

### 42.8.10 Initialization Vector Register

**Name:** INTVECTV  
**Offset:** 0x3C + n\*0x04 [n=0..3]  
**Reset:** 0x00000000  
**Property:** PAC Write-Protection

	Bit	31	30	29	28	27	26	25	24
		INTVECTV[31:24]							
Access		W	W	W	W	W	W	W	W
Reset		0	0	0	0	0	0	0	0
	Bit	23	22	21	20	19	18	17	16
		INTVECTV[23:16]							
Access		W	W	W	W	W	W	W	W
Reset		0	0	0	0	0	0	0	0
	Bit	15	14	13	12	11	10	9	8
		INTVECTV[15:8]							
Access		W	W	W	W	W	W	W	W
Reset		0	0	0	0	0	0	0	0
	Bit	7	6	5	4	3	2	1	0
		INTVECTV[7:0]							
Access		W	W	W	W	W	W	W	W
Reset		0	0	0	0	0	0	0	0

#### Bits 31:0 – INTVECTV[31:0] Initialization Vector Value

The four 32-bit Initialization Vector registers  $INTVECTV_n$  set the 128-bit Initialization Vector data block that is used by some modes of operation as an additional initial input.  $INTVECTV_0$  .  $INTVECTV$  corresponds to the first word of the Initialization Vector,  $INTVECTV_3$  .  $INTVECTV$  to the last one. These registers are write-only to prevent the Initialization Vector from being read by another application. For CBC, OFB, and CFB modes, the Initialization Vector corresponds to the initialization vector. For CTR mode, it corresponds to the counter value.

# SAM D5x/E5x Family Data Sheet

## AES – Advanced Encryption Standard

### 42.8.11 Hash Key (GCM mode only)

**Name:** HASHKEY  
**Offset:** 0x5C + n\*0x04 [n=0..3]  
**Reset:** 0x00000000  
**Property:** PAC Write-protection

	Bit	31	30	29	28	27	26	25	24
		HASHKEY[31:24]							
Access		R/W	R/W	R/W	R/W	R/W	R/W	R/W	R/W
Reset		0	0	0	0	0	0	0	0
	Bit	23	22	21	20	19	18	17	16
		HASHKEY[23:16]							
Access		R/W	R/W	R/W	R/W	R/W	R/W	R/W	R/W
Reset		0	0	0	0	0	0	0	0
	Bit	15	14	13	12	11	10	9	8
		HASHKEY[15:8]							
Access		R/W	R/W	R/W	R/W	R/W	R/W	R/W	R/W
Reset		0	0	0	0	0	0	0	0
	Bit	7	6	5	4	3	2	1	0
		HASHKEY[7:0]							
Access		R/W	R/W	R/W	R/W	R/W	R/W	R/W	R/W
Reset		0	0	0	0	0	0	0	0

**Bits 31:0 – HASHKEY[31:0] Hash Key Value**

The four 32-bit `HASHKEY` registers contain the 128-bit Hash Key value computed from the AES KEY. The Hash Key value can also be programmed offering single GF128 multiplication possibilities.

# SAM D5x/E5x Family Data Sheet

## AES – Advanced Encryption Standard

### 42.8.12 Galois Hash (GCM mode only)

**Name:** GHASH  
**Offset:** 0x6C + n\*0x04 [n=0..3]  
**Reset:** 0x00000000  
**Property:** PAC Write-Protection

	Bit	31	30	29	28	27	26	25	24
		GHASH[31:24]							
Access		R/W	R/W	R/W	R/W	R/W	R/W	R/W	R/W
Reset		0	0	0	0	0	0	0	0
	Bit	23	22	21	20	19	18	17	16
		GHASH[23:16]							
Access		R/W	R/W	R/W	R/W	R/W	R/W	R/W	R/W
Reset		0	0	0	0	0	0	0	0
	Bit	15	14	13	12	11	10	9	8
		GHASH[15:8]							
Access		R/W	R/W	R/W	R/W	R/W	R/W	R/W	R/W
Reset		0	0	0	0	0	0	0	0
	Bit	7	6	5	4	3	2	1	0
		GHASH[7:0]							
Access		R/W	R/W	R/W	R/W	R/W	R/W	R/W	R/W
Reset		0	0	0	0	0	0	0	0

**Bits 31:0 – GHASH[31:0]** Galois Hash Value

The four 32-bit Hash Word registers `GHASH` contain the `GHASH` value after GF128 multiplication in GCM mode. Writing a new key to `KEYWORD` registers causes `GHASH` to be initialized with zeroes. These registers can also be programmed.



# SAM D5x/E5x Family Data Sheet

## AES – Advanced Encryption Standard

### 42.8.13 Galois Hash x (GCM mode only)

**Name:** CIPLN  
**Offset:** 0X80  
**Reset:** 0x00000000  
**Property:** PAC Write-Protection

	Bit	31	30	29	28	27	26	25	24
		CIPLN[31:24]							
Access		R/W	R/W	R/W	R/W	R/W	R/W	R/W	R/W
Reset		0	0	0	0	0	0	0	0
	Bit	23	22	21	20	19	18	17	16
		CIPLN[23:16]							
Access		R/W	R/W	R/W	R/W	R/W	R/W	R/W	R/W
Reset		0	0	0	0	0	0	0	0
	Bit	15	14	13	12	11	10	9	8
		CIPLN[15:8]							
Access		R/W	R/W	R/W	R/W	R/W	R/W	R/W	R/W
Reset		0	0	0	0	0	0	0	0
	Bit	7	6	5	4	3	2	1	0
		CIPLN[7:0]							
Access		R/W	R/W	R/W	R/W	R/W	R/W	R/W	R/W
Reset		0	0	0	0	0	0	0	0

**Bits 31:0 – CIPLN[31:0] Cipher Length**

This register contains the length in bytes of the Cipher text that is to be processed. This is programmed by the user in GCM mode for Tag generation.

# SAM D5x/E5x Family Data Sheet

## AES – Advanced Encryption Standard

### 42.8.14 Random Seed

**Name:** RANDSEED  
**Offset:** 0x84  
**Reset:** 0x00000000  
**Property:** PAC Write-Protection

	Bit	31	30	29	28	27	26	25	24
		RANDSEED[31:24]							
Access		R/W	R/W	R/W	R/W	R/W	R/W	R/W	R/W
Reset		0	0	0	0	0	0	0	0
	Bit	23	22	21	20	19	18	17	16
		RANDSEED[23:16]							
Access		R/W	R/W	R/W	R/W	R/W	R/W	R/W	R/W
Reset		0	0	0	0	0	0	0	0
	Bit	15	14	13	12	11	10	9	8
		RANDSEED[15:8]							
Access		R/W	R/W	R/W	R/W	R/W	R/W	R/W	R/W
Reset		0	0	0	0	0	0	0	0
	Bit	7	6	5	4	3	2	1	0
		RANDSEED[7:0]							
Access		R/W	R/W	R/W	R/W	R/W	R/W	R/W	R/W
Reset		0	0	0	0	0	0	0	0

**Bits 31:0 – RANDSEED[31:0] Random Seed**

A write to this register corresponds to loading a new seed into the Random number generator.

## 43. Public Key Cryptography Controller (PUKCC)

### 43.1 Overview

The Public Key Cryptography Controller (PUKCC) processes public key cryptography algorithm calculus in both GF(p) and GF(2n) fields.

The PUKCL (Public Key Cryptography Library) is stored in ROM inside the device. This library can be used in applications to access features of PUKCC.

The Public Key Cryptography Library includes complete implementation of the following public key cryptography algorithms:

- RSA (Rivest-Shamir-Adleman public key cryptosystem), DSA (Digital Signature Algorithm):
  - Modular Exponentiation with CRT up to 7168 bits
  - Modular Exponentiation without CRT up to 5376 bits
  - Prime generation
  - Utilities: GCD/modular Inverse, Divide, Modular reduction, Multiply, ...
- Elliptic Curves:
  - ECDSA GF(p) up to 521 bits for common curves (up to 1120 bits for future use)
  - ECDSA GF(2n) up to 571 bits for common curves (up to 1440 bits for future use)
  - Choice of the curves parameters so compatibility with NIST Curves or other curves in Weierstrass equation
  - Point Multiply
  - Point Add/Doubling
  - Other high level elliptic curves algorithms (ECDH, ...) can be implemented by user using library functions
- Deterministic Random Number Generation (DRNG ANSI X9.31) for DSA

### 43.2 Product Dependencies

#### 43.2.1 I/O Lines

Not applicable.

#### 43.2.2 Power Management

The PUKCC will continue to operate in any sleep mode, as long as its source clock is running.

#### 43.2.3 Clocks

The bus clock (CLK\_PUKCC\_AHB) can be enabled and disabled by the Main Clock Controller.

#### Related Links

[15. MCLK – Main Clock](#)

#### 43.2.4 DMA

Not applicable.

#### 43.2.5 Interrupts

Not applicable.

### 43.2.6 Events

Not applicable.

## 43.3 Functional Description

### 43.3.1 Public Key Cryptography Library (PUKCL) Application Programming Interface (API)

The Public Key Cryptography Controller (PUKCC) is a peripheral that can be used to accelerate public key cryptography, and processes public key cryptography algorithm calculus in both Prime field ( $GF(p)$ ) and Binary field ( $GF(2^n)$ ). Different functionalities of the PUKCC are accessed with the help of the Public Key Cryptography Library (PUKCL), which is embedded into a dedicated ROM inside the microcontroller.

The PUKCL provides access to many algorithms and functions. The features provided, start from basic addition or comparison, up to the RSA or ECDSA complete computation. The library can be utilized by including the PUKCL Driver in the application and passing parameters through a common Application Programming Interface (API). The PUKCC Driver is available in Atmel START within *Drivers > Cryptography*. This library can be used in conjunction with a SSL software stack to improve performance and helps to reduce the RAM usage and time taken to perform different cryptographic functions.

### 43.3.2 PUKCL Features

PUKCL features include:

- [43.3.4 Basic Arithmetic and Cryptographic Services](#) - PUKCL self-test, GCD, integral division, etc.
- [43.3.5 Modular Arithmetic Services](#) - Modular reduction, modular exponentiation, probable prime generation and modular exponentiation
- [43.3.6 Elliptic Curves Over  \$GF\(p\)\$  Services](#) - Point addition and doubling on an elliptic curve in a prime field, ECDSA signature generation and verification on an elliptic curve over  $GF(p)$
- [43.3.7 Elliptic Curves Over  \$GF\(2^n\)\$  Services](#) - Point addition and doubling on an elliptic curve in a prime field, ECDSA signature generation and verification on an elliptic curve over  $GF(2^n)$

### 43.3.3 PUCKL Usage

The following sections provide details on accessing the PUKCL and its features.

#### 43.3.3.1 Initializing the PUKCC and PUKCL

For a project created with Atmel START, the clock initialization is handled by the initialization function `atmel_start_init`. After a power-on reset, and when the PUKCC Clock is enabled, a Crypto RAM clear process is launched. It is mandatory to wait until the end of this process before using the Crypto Library.

The following code shows how to wait for the Crypto RAM clear process.

```
while ((PUKCCSR & BIT_PUKCCSR_CLRRAM_BUSY) != 0);
```

The next task to be done is self-test. From the generated project in Atmel Studio, copy the example for the PUKCC Driver SelfTest and add it to the main source file. This is a mandatory step before using the library. The return values from the SelfTest service must be compared against known values mentioned in the service description (see the **Description** section in [43.3.4.1 SelfTest](#)).

#### Example 43-1. PUKCC Initialization

```
void PUKCC_self_test(void)
{
```

# SAM D5x/E5x Family Data Sheet

## Public Key Cryptography Controller (PUKCC)

```
// Clear contents of PUKCLParam
memset(&PUKCLParam, 0, sizeof(PUKCL_PARAM));

pvPUKCLParam = &PUKCLParam;
vPUKCL_Process(SelfTest, pvPUKCLParam);

// In case of error, loop here
while (PUKCL(u2Status) != PUKCL_OK) {
;
}
while (pvPUKCLParam->P.PUKCL_SelfTest.u4Version != PUKCL_VERSION) {
;
}
while (pvPUKCLParam->P.PUKCL_SelfTest.u4CheckNum1 != 0x6E70DDD2) {
;
}
while (pvPUKCLParam->P.PUKCL_SelfTest.u4CheckNum2 != 0x25C8D64F) {
;
}
}

int main(void)
{
/* Initializes MCU, drivers and middleware */
atmel_start_init();

// Wait for Crypto RAM clear process
while ((PUKCCSR & BIT_PUKCCSR_CLRRAM_BUSY) != 0);

// Initialize PUKCC and perform self test
PUKCC_self_test();
while(1)
{
}
}
```

**Note:** It may also be necessary to initialize the Random Number Generator (RNG) on the microcontroller, as some services in the library use the peripheral. Before calling such services, be sure to follow the directives given for random number generation on the selected microcontroller (particularly initialization and seeding) and compulsorily start the RNG. For details refer to each service.

### 43.3.3.2 Accessing Different Library Services

All cryptographic services in the library are accessed by the macro `vPUKCL_Process`. All of these services use the same process for receiving and returning parameters. PUKCL receives two arguments: the requested service and a pointer to a structure called the parameter block. The parameter block contains two structures, a common parameter structure for all commands and specific parameter structure for each service. A specific service is accessed with `vPUKCL_Process` by passing the service name as the first argument. For example, to perform `SelfTest`, use `vPUKCL_Process(SelfTest, pvPUKCLParam)`.

#### Example 43-2. PUKCL Parameter Block

```
typedef struct _PUKCL_param {
    PUKCL_HEADER PUKCL_Header;
    union {
        _PUKCL_CLEARFLAGS PUKCL_ClearFlags;
        _PUKCL_COMP PUKCL_Comp;
        _PUKCL_CONDCOPY PUKCL_CondCopy;
        _PUKCL_CRT PUKCL_CRT;
        _PUKCL_DIV PUKCL_Div;
        _PUKCL_EXPMOD PUKCL_ExpMod;
        _PUKCL_FASTCOPY PUKCL_FastCopy;
        _PUKCL_FILL PUKCL_Fill;
        _PUKCL_FMULT PUKCL_Fmult;
        _PUKCL_GCD PUKCL_GCD;
        _PUKCL_PRIMEGEN PUKCL_PrimeGen;
        _PUKCL_REDMOD PUKCL_RedMod;
        _PUKCL_RNG PUKCL_Rng;
    }
};
```

# SAM D5x/E5x Family Data Sheet

## Public Key Cryptography Controller (PUKCC)

```

_PUKCL_SELFTEST      PUKCL_SelfTest;
_PUKCL_SMULT         PUKCL_Smult;
_PUKCL_SQUARE       PUKCL_Square;
_PUKCL_SWAP         PUKCL_Swap;

// ECC
_PUKCL_ZPECCADD      PUKCL_ZpEccAdd;
_PUKCL_ZPECCDBL     PUKCL_ZpEccDb1;
_PUKCL_ZPECCADDSUB  PUKCL_ZpEccAddSub;
_PUKCL_ZPECCMUL     PUKCL_ZpEccMul;
_PUKCL_ZPECDSAGENERATE PUKCL_ZpEcDsaGenerate;
_PUKCL_ZPECDSAVERIFY PUKCL_ZpEcDsaVerify;
_PUKCL_ZPECDSAQUICKVERIFY PUKCL_ZpEcDsaQuickVerify;
_PUKCL_ZPECCQUICKDUALMUL PUKCL_ZpEccQuickDualMul;
_PUKCL_ZPECCONVPROJTOAFFINE PUKCL_ZpEcConvProjToAffine;
_PUKCL_ZPECCONVAFFINETOPROJECTIVE PUKCL_ZpEcConvAffineToProjective;
_PUKCL_ZPECRANDOMIZECOORDINATE PUKCL_ZpEcRandomiseCoordinate;
_PUKCL_ZPECPOINTISONCURVE PUKCL_ZpEcPointIsOnCurve;

// ECC
_PUKCL_GF2NECCADD      PUKCL_GF2NEccAdd;
_PUKCL_GF2NECCDBL     PUKCL_GF2NEccDb1;
_PUKCL_GF2NECCMUL     PUKCL_GF2NEccMul;
_PUKCL_GF2NECDSAGENERATE PUKCL_GF2NEcDsaGenerate;
_PUKCL_GF2NECDSAVERIFY PUKCL_GF2NEcDsaVerify;
_PUKCL_GF2NECCONVPROJTOAFFINE PUKCL_GF2NEcConvProjToAffine;
_PUKCL_GF2NECCONVAFFINETOPROJECTIVE PUKCL_GF2NEcConvAffineToProjective;
_PUKCL_GF2NECRANDOMIZECOORDINATE PUKCL_GF2NEcRandomiseCoordinate;
_PUKCL_GF2NECPOINTISONCURVE PUKCL_GF2NEcPointIsOnCurve;
} P;
} PUKCL_PARAM,

```

### 43.3.3.2.1 PUKCL\_HEADER Structure

The PUKCL\_HEADER is common for all services of the library. This header includes standard fields to indicate the requested service, sub-service, options, return status, and so on, as shown in the following tables.

Different terms used in the below description to be understood, are as follows:

- **Parameter** – Represents a variable used by the PUKCL. Every parameter belongs to either PUKCL\_HEADER or PUKCL Service Specific Header
- **Type** – Indicates the data type. For details on data type, please refer to CryptoLib\_typedef\_pb.h file in the library
- **Dir** – Direction. Indicates whether PUKCL considers the variable as input or output. Input means that the application passes data to the PUKCL using the variable. Output means that the PUKCL uses the variable to pass data to the application.
- **Location** – Suggests whether the parameter need to be stored in Crypto RAM or device SRAM. The PUKCL driver has macros for placing parameters into Crypto RAM, so that the user does not have to worry about the addresses
- **Data Length** – If a parameter is a pointer variable, the Data Length column shows the size of the data pointed by the pointer

**Table 43-1. PUKCL\_HEADER Structure**

Parameter	Type	Direction	Location	Data Length	Before Executing the Service	After Executing the Service
u1Service	u1	I	–	–	Required service	Executed service
u1SubService	u1	I	–	–	Required sub-service	Executed sub-service
u2Option	u2	I	–	–	Required option	Executed option
Specific	PUKCL_STATUS	I/O	–	–	See <a href="#">Table 43-2</a>	See <a href="#">Table 43-2</a>

# SAM D5x/E5x Family Data Sheet

## Public Key Cryptography Controller (PUKCC)

.....continued

Parameter	Type	Direction	Location	Data Length	Before Executing the Service	After Executing the Service
u2Status (see 43.3.3.6 Return Codes)	u2	I/O	–	–	–	Output Status
Reserved	u2	–	–	–	–	–
Reserved	u4	–	–	–	–	–

The Specific field in the PUKCL\_HEADER structure is another structure named PUKCL\_STATUS. The following table describes this structure. The details of the use of these bits are provided in the individual service descriptions.

### 43.3.3.2.2 PUKCL\_STATUS Structure

Members of the PUKCL\_STATUS structure are shown in the following table.

**Table 43-2. PUKCL\_STATUS Structure**

Parameter	Type	Direction	Location	Data Length	Before Executing the Service	After Executing the Service
CarryIn (see Note 1)	bit	I	–	–	CarryIn	–
CarryOut	bit	O	–	–	–	CarryOut
Zero	bit	O	–	–	–	1: Result is zero 0: Result is not zero
Gf2n (see Note 1)	bit	I	–	–	Mathematical field 0: Integers ( $Z_p$ ) 1: Field $GF(2^n)$	–
Violation	bit	O	–	–	–	Indicates a violation

**Note:**

- Two of these fields must be filled in to avoid problems during computations. If the Gf2n and CarryIn fields are not reset or initialized properly, problems may be encountered during computations. For instance, not initializing the Gf2n field may result in getting a correct mathematical result, but computed over  $GF(2^n)$  instead of  $Z_p$ .

### 43.3.3.2.3 PUKCL Service Specific Header

Details about each service specific header are provided with service descriptions in a subsequent section. Such structures may contain input or output parameters. A parameter is considered as an input parameter when it used for passing information to the PUKCL, and it is considered as an output parameter when the PUKCL uses it to pass a result back to the application code.

The following code provides the service specific header example for the SelfTest service.

```
typedef struct _PUKCL_selftest {
    u4 u4Version;
    u4 u4PUKCCVersion;
    u4 u4CheckNum1;
    u4 u4CheckNum2;
    u1 u1Step;
} _PUKCL_SELFTEST;
```

After the SelfTest service is invoked (with `vPUKCL_Process(SelfTest, pvPUKCLParam)`), the service specific return values can be checked using `pvPUKCLParam`.

# SAM D5x/E5x Family Data Sheet

## Public Key Cryptography Controller (PUKCC)

To check whether the version returned by the PUKCL is correct, the following code can be used.

```
while (pvPUKCLParam->P.PUKCL_SelfTest.u4Version != PUKCL_VERSION);
```

In a similar way, other returns can also be accessed.

### 43.3.3.3 Parameter Passing (Special Considerations)

Most of the PUKCL services work with memory area and accept pointers and lengths as parameters to define input and output areas. Most of the time, the pointers and lengths are untouched by the services, while the defined areas are read, filled, or overwritten. These memory areas are defined with an initial pointer and a byte length. For most of the commands, the memory area location must be in the PUKCC Cryptographic RAM. The Cryptographic RAM is the memory area for parameter exchange with the PUKCL and is 4 Kbytes large. Sometimes memory areas can be located in Embedded SRAM, which is detailed in the Location column of the parameters description tables.

When working with binary fields, polynomials in  $GF(2^n)$  need no transformation to be written in an area:

- Each bit represents a polynomial coefficient 0 or 1
- The polynomials must be written Low Significant Byte First
- A zero padding on the Most Significant Bytes may be added if the area is larger than the real size of the polynomial



**Important:** The Cryptographic RAM is 4 Kbytes in size and is dedicated to PUKCC. However, to ensure correct library operation, the two last 32-bit words must not be used. Unless otherwise specified, these memory areas contain integers in  $GF(p)$  or polynomials in  $GF(2^n)$  with the Less Significant Byte first.

Unless otherwise specified, the length must be a multiple of four and the pointers must be four bytes aligned. This is because most of the services work with 32-bit words.

### 43.3.3.4 Aligned Significant Length

Parameters in memory areas can have any Significant Length in bytes. As the lengths in PUKCL must be a multiple of four, a padding is processed on the Most Significant Side with zero to three bytes cleared to zero. Now the parameter can be considered to meet the Aligned Significant Length requirement for PUKCL.

### 43.3.3.5 Processing Field $GF(p)$ and $GF(2^n)$

The library can process arithmetic functions over  $GF(p)$  (or  $Z_p$  integers) and  $GF(2^n)$ , when applicable. The choice of these processing fields is made using the following rules:

- If a processing field is not applicable to the function, it is not mentioned and the Specific.GF2n bit has no effect.
- If the function can support both processing fields, the choice is mentioned and the Specific.GF2n bit must be filled according to the choice.
- If the function supports only one of the processing fields, the processing field is mentioned and the Specific.GF2n bit has no effect.

### 43.3.3.6 Return Codes

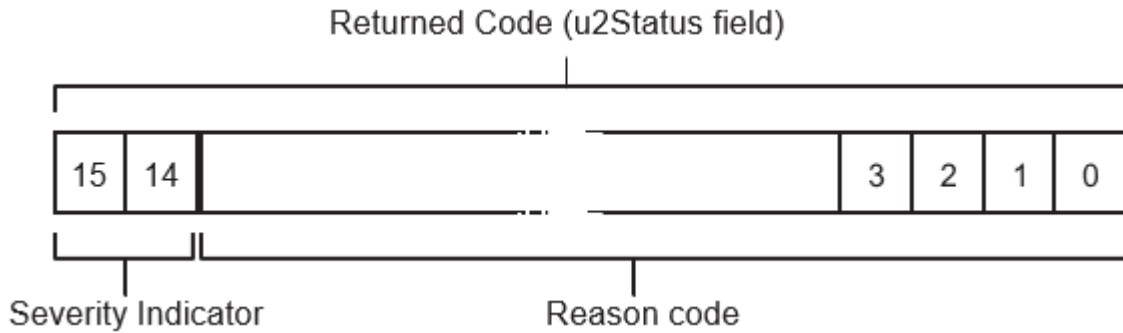
Each call to one of the PUKCL services returns a status code indicating whether or not the execution is correct, which can be decoded, as shown in the following figure.



# SAM D5x/E5x Family Data Sheet

## Public Key Cryptography Controller (PUKCC)

**Figure 43-1. Return Code Status Decoding**



The following table shows how the severity indicators should be decoded.

**Table 43-3. Severity Indicators**

Value for Bits 14–15	Severity	Comment
0xC000	Severe	Indicates a blocking error condition
0x8000	Warning	Indicates a cautionary use of the return values
0x4000	Information	Indicates the result is correct and gives information
0x0000	–	No error or no severity given

The following table contains the exhaustive list of all reason codes.

**Table 43-4. Return Codes**

Value for Bits 00–13	Severity Code	Reason Code
0x0000	–	PUKCL_OK
0x4001	Informative	PUKCL_NUMBER_IS_NOT_PRIME
0x4002	Informative	PUKCL_NUMBER_IS_PRIME
0xC001	Severe	PUKCL_COMPUTATION_NOT_STARTED
0xC002	Severe	PUKCL_UNKNOWN_SERVICE
0xC003	Severe	PUKCL_UNEXPLOITABLE_OPTIONS
0xC004	Severe	PUKCL_HARDWARE_ISSUE
0xC005	Severe	PUKCL_WRONG_HARDWARE
0xC006	Severe	PUKCL_LIBRARY_MALFORMED
0xC007	Severe	PUKCL_ERROR
0xC008	Severe	PUKCL_UNKNOWN_SUBSERVICE
0xC101	Severe	PUKCL_DIVISION_BY_ZERO
0xC102	Severe	PUKCL_MALFORMED_MODULUS
0xC103	Severe	PUKCL_FAULT_DETECTED
0xC104	Severe	PUKCL_MALFORMED_KEY

# SAM D5x/E5x Family Data Sheet

## Public Key Cryptography Controller (PUKCC)

Please note the following rules about return codes:

- A status value indicating a severe error, means that an expected operation has not been executed or has been corrupted. Therefore, the result of such an operation should never be used.
- A status value indicating a warning should be looked at precisely, as the expected correctness of the result cannot be guaranteed.
- A status value indicating an information always means that the result is correct with no possible misinterpretation of the values.
- A status value zero indicates that there is no error or no severity.

In the following sections, for each service, the constraints on the parameters placement are detailed. For reduced code size and higher execution speed, tests are processed on these constraints. It is important that PUKCL users take these placement constraints into consideration at the development and test stages to ensure the correct functioning of the library.

### 43.3.4 Basic Arithmetic and Cryptographic Services

#### 43.3.4.1 SelfTest

##### 43.3.4.1.1 Purpose

This service is used to initialize the PUKCL. It resets the PUKCC, clears the Crypto RAM, and returns the library and PUKCC version numbers.

It must be called before using any other services in the library and the user must verify the return status at the end of the service execution.

##### 43.3.4.1.2 How to Use the Service

##### 43.3.4.1.3 Description

This service processes internal tests and returns information and status codes as described in [43.3.4.1.7 Status Returned Values](#). The service name for this operation is `SelfTest`.

##### 43.3.4.1.4 Parameters Definition

It is possible to directly address this service through the `PUKCL_SelfTest()` macro.

**Table 43-5. SelfTest Service Parameters**

Parameter	Type	Dir.	Location	Data Length	Before Executing the Service	After Executing the Service
u4Version	u4	O	–	–	–	PUKCL version
u4PUKCCVersion	u4	O	–	–	–	PUKCC Version
u4CheckNum1	u4	O	–	–	–	Test result value 1
u4CheckNum2	u4	O	–	–	–	Test result value 2
u1Step	u1	O	–	–	–	Latest correctly executed step

##### 43.3.4.1.5 Code Example

```
PUKCL_PARAM PUKCLParam;
P_PUKCL_PARAM pvPUKCLParam = &PUKCLParam;

// vPUKCL_Process() is a macro command, which populates the service name
// and then calls the library
vPUKCL_Process(SelfTest, pvPUKCLParam);

if (PUKCL(u2Status) == PUKCL_OK)
```

# SAM D5x/E5x Family Data Sheet

## Public Key Cryptography Controller (PUKCC)

```

{
// The Library version is available
// in PUKCL_SelfTest(u4Version)
// The PUKCL version is available
// in PUKCL_SelfTest(u4PUKCCVersion)
}

```

### 43.3.4.1.6 Returned Values

The expected u4Version value depends on the version of PUKCL being used, and the u4PUKCCVersion value depends on the version of PUKCC being used.

The expected u4CheckNum1 value is 0x6e70ddd2 and the expected one for u4CheckNum2 is 0x25c8d64f. The expected final u1Step value is 3.

### 43.3.4.1.7 Status Returned Values

**Table 43-6. SelfTest Service Return Codes**

Returned Status	Importance	Meaning
PUKCL_OK	–	Service functioned correctly.
PUKCL_ERROR	Severe	An issue has been encountered.

### 43.3.4.2 Clear Flags

#### 43.3.4.2.1 Purpose

This service can be used to clear parameter structure flags.

#### 43.3.4.2.2 How to Use the Service

#### 43.3.4.2.3 Description

This service clears CarryOut, CarryIn, Zero and Violation flags in the Specific bit field. The Gf2n flag is untouched.

The service name for this operation is `ClearFlags`.

#### 43.3.4.2.4 Parameters Definition

It is possible to directly address this service through the `PUKCL_ClearFlags()` macro.

**Table 43-7. Clear Flags Service Parameters**

Parameter	Type	Direction	Location	Data Length	Before Executing the Service	After Executing the Service
Specific/CarryOut	Bit	O	–	–	–	Cleared
Specific/CarryIn	Bit	O	–	–	–	Cleared
Specific/Zero	Bit	O	–	–	–	Cleared
Specific/Violation	Bit	O	–	–	–	Cleared

#### 43.3.4.2.5 Code Example

```

PUKCL_PARAM PUKCLParam;
PUPUKCL_PARAM pvPUKCLParam = &PUKCLParam;

// vPUKCL_Process() is a macro command, which populates the service name
// and then calls the library...
vPUKCL_Process(ClearFlags,pvPUKCLParam);
if (PUKCL(u2Status) == PUKCL_OK)
{
// Success
}

```

# SAM D5x/E5x Family Data Sheet

## Public Key Cryptography Controller (PUKCC)

```

    }
else // Manage the error

```

### 43.3.4.2.6 Status Returned Values

**Table 43-8. ClearFlags Service Return Codes**

Returned Status	Importance	Meaning
PUKCL_OK	–	Service functioned correctly.

### 43.3.4.3 Swap

#### 43.3.4.3.1 Purpose

This service performs swapping of two buffers.

#### 43.3.4.3.2 How to Use the Service

#### 43.3.4.3.3 Description

This service swaps two buffers, X and Y, of the same size in memory.

The service name for this operation is *Swap*.

#### 43.3.4.3.4 Parameters Definition

This service can easily be accessed through the use of the `PUKCL_Swap()` macro.

**Table 43-9. Swap Service Parameters**

Parameter	Type	Direction	Location	Data Length	Before Executing the Service	After Executing the Service
nu1XBase	nu1	I	Crypto RAM	u2Length	Base of the number X	Base of X filled with Y
nu1YBase	nu1	I	Crypto RAM	u2Length	Base of the number Y	Base of Y filled with X
u2XLength	u2	I	–	–	Length of X and Y	Length of X and Y

#### 43.3.4.3.5 Code Example

```

PARAM PUKCLParam;
PUKCL_PARAM pvPUKCLParam = &PUKCLParam;

// Initialize parameters
PUKCL_Swap(nu1XBase) = <Base of the X number>;
PUKCL_Swap(nu1YBase) = <Base of the Y number>;
PUKCL_Swap(u2XLength) = <Length of the numbers>;

// vPUKCL_Process() is a macro command, which populates the service name
// and then calls the library...
vPUKCL_Process(Swap,pvPUKCLParam);
if (PUKCL(u2Status) == PUKCL_OK)
{
    ...
}
else // Manage the error

```

#### 43.3.4.3.6 Constraints

The following conditions must be avoided to ensure that the service works correctly:

- nu1XBase or nu1YBase are not aligned on 32-bit boundaries
- u2XLength is either <4, > 0xffc, or not a 32-bit length
- {nu1XBase, u2XLength} or {nu1YBase, u2XLength} do not entirely lie in PUKCCRAM

# SAM D5x/E5x Family Data Sheet

## Public Key Cryptography Controller (PUKCC)

- {nu1XBase, u2XLength} overlaps {nu1YBase,u2YLength}

### 43.3.4.3.7 Status Returned Values

**Table 43-10. Swap Service Return Codes**

Returned status	Importance	Meaning
PUKCL_OK	–	Service functioned correctly

### 43.3.4.4 Fill

#### 43.3.4.4.1 Purpose

This service performs a memory fill operation, with a given 32-bit constant.

#### 43.3.4.4.2 How to Use the Service

#### 43.3.4.4.3 Description

This service fills a Crypto RAM space with a provided 32-bit constant: Fill (R, FillValue)

The service name for this operation is `Fill`.

#### 43.3.4.4.4 Parameters Definition

This service can easily be accessed through the use of the `PUKCL_Fill()` macro.

**Table 43-11. Fill Service Parameters**

Parameter	Type	Direction.	Location	Data Length	Before Executing the Service	After Executing the Service
nu1RBase	nu1	I	Crypto RAM	u2RLength	Base of R	Base of R value filled repetitively with u4FillValue
u2RLength	u2	I	Crypto RAM	–	Length of R	Length of R
u4FillValue	u4	I	–	–	Filling value	Filling value

#### 43.3.4.4.5 Code Example

```

PUKCL_PARAM PUKCLParam;
PPUKCL_PARAM pvPUKCLParam = &PUKCLParam;

// Initialize parameters
PUKCL_Fill(nu1RBase) = <Base of the R number>;
PUKCL_Fill(u2RLength) = <Length of the R number>;
PUKCL_Fill(u4FillValue) = <32-bits value to fill with>;

// vPUKCL_Process() is a macro command, which populates the service name
// and then calls the library...
vPUKCL_Process(Fill,pvPUKCLParam);
if (PUKCL(u2Status) == PUKCL_OK)
{
    ...
}
else // Manage the error

```

#### 43.3.4.4.6 Constraints

The following conditions must be avoided to ensure that the service works correctly:

- nu1RBase are not aligned on 32-bit boundaries
- u2RLength is either: <4, >0xffc or not a 32-bit length
- {nu1RBase, u2RLength} do not entirely lie in Crypto RAM

# SAM D5x/E5x Family Data Sheet

## Public Key Cryptography Controller (PUKCC)

### 43.3.4.4.7 Status Returned Values

**Table 43-12. Fill Service Return Codes**

Returned Status	Importance	Meaning
PUKCL_OK	–	Service functioned correctly.

### 43.3.4.5 Fast Copy/Clear

#### 43.3.4.5.1 Purpose

This service performs a copy from a memory area to another or a memory area clear.

#### 43.3.4.5.2 How to Use the Service

#### 43.3.4.5.3 Description

This service copies a number X into another number R, padding with zero on the MSB side up to the length specified for R.

$$R = X$$

If the lengths of R and X are equal, a complete fast copy is processed.

If the length of R is strictly greater than the length of X, X is first copied in the Low Significant Bytes side of R, and R is padded with zeros on the Most Significant Bytes side.

If the pointer on the X area equals zero, R is filled with zeros. This operation can also be made by using the Fill service (see [43.3.4.4 Fill](#)).

The service name for this operation is `FastCopy`.



**Important:** The length of R must be greater or equal to the length of X.

#### 43.3.4.5.4 Parameters Definition

This service can easily be accessed through the use of the `PUKCL_FastCopy()` macro.

**Table 43-13. FastCopy Service Parameters**

Parameter	Type	Direction	Location	Data Length	Before Executing the Service	After Executing the Service
nu1XBase	nu1	I	Crypto RAM	u2XLength	Base of X	Base of X number untouched
nu1RBase	nu1	I	Crypto RAM	u2RLength	Base of R	Base of R filled with X
u2RLength	u2	I	–	–	Length of R	Length of R
u2XLength	u2	I	–	–	Length of X	Length of X

#### 43.3.4.5.5 Code Example

```

PUKCL_PARAM PUKCLParam;
P_PUKCL_PARAM pvPUKCLParam = &PUKCLParam;

// Initialize parameters
PUKCL_FastCopy(nu1XBase) = <Base of the X number>;
PUKCL_FastCopy(nu1RBase) = <Base of the R number>;
PUKCL_FastCopy(u2XLength) = <Length of the X number>;
PUKCL_FastCopy(u2RLength) = <Length of the R number>;

```

# SAM D5x/E5x Family Data Sheet

## Public Key Cryptography Controller (PUKCC)

```
// vPUKCL_Process() is a macro command, which populates the service name
// and then calls the library...
vPUKCL_Process(FastCopy,pvPUKCLParam);
if (PUKCL(u2Status) == PUKCL_OK)
{
    ...
}
else // Manage the error
```

### 43.3.4.5.6 Constraints

The parameter placements that are not allowed are as follows.

If nu1XBase equals zero, no checks are made on nu1XBase (fixed) and u2XLength (unused).

The following conditions must be avoided to ensure that the service works correctly:

- nu1XBase or nu1RBase are not aligned on 32-bit boundaries
- u2XLength or u2RLength is either: <4, >0xffc or not a 32-bit length or u2XLength >u2RLength
- {nu1XBase, u2XLength} or {nu1RBase, u2RLength} do not entirely lie in Crypto RAM
- {nu1XBase, u2XLength} overlaps {nu1RBase,u2RLength}

### 43.3.4.5.7 Status Returned Values

**Table 43-14. FastCopy Service Return Codes**

Returned status	Importance	Meaning
PUKCL_OK	–	Service functioned correctly

### 43.3.4.6 Conditional Copy/Clear

#### 43.3.4.6.1 Purpose

This service conditionally performs a copy from a memory area to another or a memory area clear.

#### 43.3.4.6.2 How to Use the Service

#### 43.3.4.6.3 Description

This service copies a number X into another number R, padding with zero on the MSB side up to the length specified for R. This copy operation is performed under the conditions specified in the options.

If the condition is verified,  $R = X$ .

The copy or clear action is made under condition.

The four possible options for the condition are described in the following table. Two of the conditions check the Specific.CarryIn bit (see [43.3.3.2 Accessing Different Library Services](#)).

The processing is done as follows:

- If the condition is not verified, nothing is processed.
- If the condition is verified the copy or clear follows the rules:
  - If the lengths of R and X are equal, a complete fast copy is processed
  - If the length of R is strictly greater than the length of X, X is first copied in the Low Significant Bytes side of R, and R is padded with zeros on the Most Significant Bytes side.
  - If the pointer on the X area equals zero, R is filled with zeros.

The service name for this operation is `CondCopy`.

# SAM D5x/E5x Family Data Sheet

## Public Key Cryptography Controller (PUKCC)



**Important:** If the condition is verified, the length of R must be greater or equal to the length of X.

### 43.3.4.6.4 Parameters Definition

This service can easily be accessed through the use of the `PUKCL_CondCopy()` and `PUKCL()` macros.

**Table 43-15. CondCopy Service Parameters**

Parameter	Type	Direction	Location	Data Length	Before Executing the Service	After Executing the Service
u2Options	u2	I	–	–	Option for condition (see the following table)	Option for condition (see the following table)
Specific/CarryIn	Bit	I	–	–	Bit CarryIn	Bit CarryIn
nu1XBase	nu1	I	Crypto RAM	u2XLength	Base of X	Base of X number untouched
nu1RBase	nu1	I	Crypto RAM	u2RLength	Base of R	Base of R filled with X if condition holds
u2RLength	u2	I	–	–	Length of R	Length of R
u2XLength	u2	I	–	–	Length of X	Length of X

### 43.3.4.6.5 Available Options

The option for the condition is set by the `u2Options` input parameter that must take one of the values listed in the following table.

**Table 43-16. CondCopy Service Options**

Option	Purpose	Needed parameters
<code>PUKCL_CONDCOPY_ALWAYS</code>	Always perform the copy	<code>nu1XBase</code> , <code>u2XLength</code> , <code>nu1RBase</code> , <code>u2RLength</code>
<code>PUKCL_CONDCOPY_NEVER</code>	Never perform the copy	None
<code>PUKCL_CONDCOPY_IF_CARRY</code>	Perform the copy if CarryIn is 1	<code>Specific/CarryIn</code> , <code>nu1XBase</code> , <code>u2XLength</code> , <code>nu1RBase</code> , <code>u2RLength</code>
<code>PUKCL_CONDCOPY_IF_NOT_CARRY</code>	Perform the copy if CarryIn is zero	<code>Specific/CarryIn</code> , <code>nu1XBase</code> , <code>u2XLength</code> , <code>nu1RBase</code> , <code>u2RLength</code>

### 43.3.4.6.6 Code Example

```

PUKCL_PARAM PUKCLParam;
PUPUKCL_PARAM pvPUKCLParam = &PUKCLParam;

// CarryIn shall be beforehand filled (with zero or one) PUKCL(Specific).CarryIn = ...;

```



# SAM D5x/E5x Family Data Sheet

## Public Key Cryptography Controller (PUKCC)

```

// Condition Option PUKCL(u2Options) = ...;

// Initialize parameters
PUKCL_CondCopy(nu1XBase) = <Base of the X number>;
PUKCL_CondCopy(nu1RBase) = <Base of the R number>;
PUKCL_CondCopy(u2XLength) = <Length of the X number>;
PUKCL_CondCopy(u2RLength) = <Length of the R number>;

// vPUKCL_Process() is a macro command, which populates the service name
// and then calls the library...
vPUKCL_Process(CondCopy,pvPUKCLParam);
if (PUKCL(u2Status) == PUKCL_OK)
{
    ...
}
else // Manage the error

```

### 43.3.4.6.7 Constraints

The parameters placement that are not allowed are listed below.

If the conditional option and the CarryIn do not lead to execute the copy, no checks are made on the constraints to be respected.

If nu1XBase equals zero, no checks are made on nu1XBase (fixed) and u2XLength (unused).

The following conditions must be avoided to ensure that the service works correctly:

- nu1XBase or nu1RBase are not aligned on 32-bit boundaries
- u2XLength or u2RLength is either: <4, >0xffc or not a 32-bit length or u2XLength >u2RLength
- {nu1XBase, u2XLength} or {nu1RBase, u2RLength} do not entirely lie in Crypto RAM
- {nu1XBase, u2XLength} overlaps {nu1RBase,u2RLength}

### 43.3.4.6.8 Status Returned Values

**Table 43-17. CondCopy Service Return Codes**

Returned status	Importance	Meaning
PUKCL_WRONG_SERVICE	Severe	An inconsistency has been detected between the called service and the provided service number.
PUKCL_OK	–	Service functioned correctly

### 43.3.4.7 Small Multiply, Add, Subtract, Exclusive OR

#### 43.3.4.7.1 Purpose

This purpose of this service is to multiply a large number X by a single-word number, MulValue, and perform an optional accumulation/subtract with a large number Z, returning the result R.

The following options are available:

- Work in the GF(2<sup>n</sup>) or in the standard GF(p) arithmetic integer field
- Add of a supplemental CarryOperand
- Overlap of the operands is possible, taking into account some constraints
- Modulo-reduction of the computation result (see [43.3.5.1 Modular Reduction](#))

In addition to a multiply, possible uses of this service can include:

- Copy a block of data from one place to another (if u4MulValue is 1). This operation can alternatively be made by using the Fast Copy service (see [43.3.4.5 Fast Copy/Clear](#)).
- Adding/Subtracting two numbers (if u4MulValue is 1)
- Xoring two blocks of data (if u4MulValue is 1 and the selected mathematical field is GF(2<sup>n</sup>))

### 43.3.4.7.2 How to Use the Service

#### 43.3.4.7.3 Description

This service processes the following operation (if not computing a modular reduction of the result):

$$R = [Z] \pm (MulValue \times X + CarryOperand)$$

Or (if computing a modular reduction of the result):

$$R = ([Z] \pm (MulValue \times X + CarryOperand)) \bmod N$$

The service name for this operation is `Smult`.

The result of the Small Multiply Operation is stored on `u2RLength` bytes, so the choice of this length compared to `u2XLength` may lead to:

- A truncation if the result is too big to be stored on `u2RLength` bytes.
  - A padding on the MSB side if the result does not take all the `u2RLength` bytes.
- However, in all cases this rule must be followed:



**Important:** The length of R must be greater than or equal to the length of X.

---

In these computations, the following parameters need to be provided:

- R the result (pointed by `{nu1RBase,u2RLength}`)
- X one input number or  $GF(2^n)$  polynomial (pointed by `{nu1XBase,u2XLength}`)
- Z one optional input number or  $GF(2^n)$  polynomial (pointed by `{nu1ZBase,u2RLength}`).
- `MulValue` one input number or  $GF(2^n)$  polynomial on one word (provided in `u4MulValue`)
- `CarryOperand` (provided through the `CarryOptions` and `Carry` values).



**Important:** Even if neither accumulation nor subtraction is specified, the `nu1ZBase` must always be filled and point to a Crypto RAM space. In this case, `nu1ZBase` can point to the same space as the `nu1RBase`.

---

If using the modular reduction option, the Multiply operation is followed by a reduction (see [43.3.5.1 Modular Reduction](#)) and the following parameters must be additionally provided:

- N—the modulus (pointed by `{nu1ModBase,u2Modlength +4}`)
- Cns—the reduction constant
  - In case of Big reduction, Cns is pointed by `{nu1CnsBase,64bytes}`.
  - In case of Fast or Normalized reduction, Cns is pointed by `{nu1CnsBase,u2ModLength +8}`

# SAM D5x/E5x Family Data Sheet

## Public Key Cryptography Controller (PUKCC)



**Important:**

The result buffer R must first be padded with zero bytes until its length is sufficient to perform the reduction ( $2 \cdot u2ModLength + 8$ ) to be used by the Modular Reduction service as an input parameter.

The result of the reduction is written in the area X pointed by  $\{nu1XBase, u2ModLength + 4\}$ .

- For example, if relevant  $u2ModLength$  is 0x80 bytes and  $u2XLength$  is 0x80 too, the length of the Rspace may be  $2 \cdot (u2ModLength + 4) = 0x108$  bytes.  
In case of fast or normalized reduction, the length of the result may be  $u2ModLength + 4$  so 0x84 bytes. Therefore, the zone X may lengths 0x84 bytes (at least). The multiplication of X by 1 word provide a result in the zone R which MSB bytes will be padded with zero bytes.

In that example, the length of the zone R will be  $2 \cdot u2ModLength + 8 = 0x108$  bytes.

#### 43.3.4.7.4 Parameters Definition

**Table 43-18. Smult Service Parameters**

Parameter	Type	Direction	Location	Data Length	Before Executing the Service	After Executing the Service
u2Options	u2	I	–	–	Options (see below)	Options (see below)
Specific/Gf2n CarryIn	Bits	I	–	–	GF(2 <sup>n</sup> ) Bit and Carry In	–
Specific/CarryOut Zero Violation	Bits	I	–	–	–	Carry Out, Zero Bit and Violation Bit filled according to the result
nu1ModBase	nu1	I	Crypto RAM	$u2ModLength + 4$	Base of N	Base of N untouched
nu1CnsBase	nu1	I	Crypto RAM	$u2ModLength + 8$	Base of Cns	Base of Cns untouched
u2ModLength	u2	I	–	–	Length of N	Length of N
nu1XBase	nu1	I	Crypto RAM	$u2XLength$ or $u2ModLength + 4$ (see <b>Note 1</b> )	Base of X	Base of X ( see <b>Note 2</b> )
u2XLength	u2	I	–	–	Length of X	Length of X
nu1ZBase	nu1	I	Crypto RAM	$u2RLength$	Base of Z	Base of Z untouched
nu1RBase	nu1	I	Crypto RAM	$u2RLength$	Base of R	Base of R (see <b>Note 3</b> )
u2RLength	u2	I	–	–	Length of R	Length of R

# SAM D5x/E5x Family Data Sheet

## Public Key Cryptography Controller (PUKCC)

.....continued

Parameter	Type	Direction	Location	Data Length	Before Executing the Service	After Executing the Service
u4MulValue	u4	I	–	–	Value of MulValue	Value of MulValue untouched

**Note:**

1. If a reduction option is specified, the area X will be, if necessary, extended to u2ModLength + 4 bytes.
2. If Smult is without reduction, X is untouched. If Smult is with reduction, X is filled with the final result.
3. If Smult is without reduction, R is filled with the final result. If Smult is with reduction, R is corrupted.

### 43.3.4.7.5 Available Options

The options are set by the u2Options input parameter, which is composed of:

- the mandatory Small Multiplication operation option described in [Table 43-19](#)
- the mandatory CarryOperand option described in [Table 43-20](#) and [Table 43-21](#)
- the facultative Modular Reduction option (see [43.3.5.1 Modular Reduction](#)). If the Modular Reduction is not requested, this option is absent.

The u2Options number is calculated by an “Inclusive OR” of the options. Some examples in C language are:

- Operation: Small Multiply only without carry and without Modular Reduction  

```
PUKCL(u2Options) = SET_MULTIPLIEROPTION(PUKCL_SMULT_ONLY) |
SET_CARRYOPTION(CARRY_NONE);
```
- Operation: Small Multiply with addition with Specific/CarryIn addition and with Fast Modular Reduction  

```
PUKCL(u2Options) =SET_MULTIPLIEROPTION(PUKCL_SMULT_ADD) |
SET_CARRYOPTION(ADD_CARRY) | PUKCL_REDMOD_REDUCTION |
PUKCL_REDMOD_USING_FASTRED;
```

The following table lists all of the necessary parameters for the Small Multiply option. When the Addition or Subtraction option is not chosen, it is not necessary to fill in the nu1ZBase parameter.

**Table 43-19. Smult Service Operation Options**

Option	Purpose	Required Parameters
SET_MULTIPLIEROPTION(PUKCL_SMULT_ONLY)	Perform $R = \text{MulValue} * X + \text{CarryOperand}$	nu1RBase, u2RLength, nu1XBase, u2XLength, u4MulValue
SET_MULTIPLIEROPTION(PUKCL_SMULT_ADD)	Perform $R = Z + \text{MulValue} * X + \text{CarryOperand}$	nu1RBase, u2RLength, nu1ZBase, nu1XBase, u2XLength, u4MulValue
SET_MULTIPLIEROPTION(PUKCL_SMULT_SUB)	Perform $R = Z - (\text{MulValue} * X + \text{CarryOperand})$	nu1RBase, u2RLength, nu1ZBase, nu1XBase, u2XLength, u4MulValue

### 43.3.4.7.6 Code Example

```
PUKCL_PARAM PUKCLParam;
pvPUKCL_PARAM pvPUKCLParam = &PUKCLParam;

// Gf2n and CarryIn shall be beforehand filled (with zero or one)
PUKCL(Specific).Gf2n = ...;
PUKCL(Specific).CarryIn = ...; PUKCL(u2Options) =...;

// Depending on the option specified, not all fields should be filled
PUKCL_Smult(nu1XBase) = <Base of the X number>;
PUKCL_Smult(u2XLength) = <Length of the X number>;
PUKCL_Smult(nu1RBase) = <Base of the R number>;
PUKCL_Smult(u2RLength) = <Length of the R number>;
PUKCL_Smult(nu1ZBase) = <Base of the Z number>;
PUKCL_Smult(u4MulValue) = <Value to be multiplied with>;

// vPUKCL_Process() is a macro command, which populates the service name
// and then calls the library...
vPUKCL_Process(Smult,pvPUKCLParam);
if (PUKCL(u2Status) == PUKCL_OK)
{
    // The Small multiplication has been executed correctly
    ...
}
else // Manage the error
```

#### Note:

The length of R must be greater or equal to the length of X. Additional options are available through the use of a modular reduction to be executed at the end of this operation. Some important considerations have to be taken into account concerning the length of resulting operands to get a mathematically correct result.

The output of this operation is not obviously compatible with the modular reduction, as it may be either smaller or bigger. In the case (most of the time) where the result (pointed by nu1RBase) is smaller in size than twice the modulus plus one word, it is mandatory to add padding bytes to zero. Otherwise, the reduced value will be taken considering the high order words (potentially uninitialized) as part of the number, thus resulting in a mathematically correct but unexpected result.

In the case that the result is bigger than twice the modulus plus one word, the modular reduction feature has to be executed as a separate operation, using an Euclidean division.

### 43.3.4.7.7 Constraints

For the case of a small multiplication with an option indicating either subtraction or accumulation, the following conditions must be avoided to ensure the service works correctly:

- nu1XBase, nu1RBase or nu1ZBase are not aligned on 32-bit boundaries
- {nu1XBase, u2XLength}, {nu1ZLength, u2RLength} or {nu1RBase, u2RLength} do not entirely lie in Crypto RAM
- u2XLength or u2RLength is either: < 4, > 0xffc or not a 32-bit length or u2XLength > u2RLength
- {nu1RBase, u2RLength} overlaps {nu1XBase, u2XLength} or nu1R < nu1Z and {nu1RBase, u2RLength} overlaps {nu1ZBase, u2RLength}

If the nu1R value is greater or equals to the nu1Z one, the overlapping between R and Z is allowed.

If a modular reduction is specified, the relevant parameters must be defined according to the chosen reduction and follow the description in [43.3.5.1 Modular Reduction](#). Additional constraints to be respected and error codes are described in this section and in [Table 43-22](#).

#### **Multiplication with Accumulation or Subtraction**

When the options bits specify that either an Accumulation or a Subtraction should be performed, this service performs the following operation:

# SAM D5x/E5x Family Data Sheet

## Public Key Cryptography Controller (PUKCC)

$$R = (Z \pm (\text{MulValue} \times X + \text{CarryOperand})) \bmod B^{\text{RLength}}$$

**Table 43-20. Smult Service (with Accumulate/Subtract From) Carry Settings**

Carry Options	CarryOperand	Resulting Operation
SET_CARRYOPTION(ADD_CARRY)	CarryIn	$R = Z \pm (\text{MulValue} * X + \text{CarryIn})$
SET_CARRYOPTION(SUB_CARRY)	- CarryIn	$R = Z \pm (\text{MulValue} * X - \text{CarryIn})$
SET_CARRYOPTION(ADD_1_PLUS_CARRY)	1 + CarryIn	$R = Z \pm (\text{MulValue} * X + 1 + \text{CarryIn})$
SET_CARRYOPTION(ADD_1_MINUS_CARRY)	1 - CarryIn	$R = Z \pm (\text{MulValue} * X + 1 - \text{CarryIn})$
SET_CARRYOPTION(CARRY_NONE)	0	$R = Z \pm (\text{MulValue} * X)$
SET_CARRYOPTION(ADD_1)	1	$R = Z \pm (\text{MulValue} * X + 1)$
SET_CARRYOPTION(SUB_1)	- 1	$R = Z \pm (\text{MulValue} * X - 1)$
SET_CARRYOPTION(ADD_2)	2	$R = Z \pm (\text{MulValue} * X + 2)$

### **Multiplication without Accumulation or Subtraction**

When the case the options bits specify that neither an Accumulation nor a Subtraction should be performed, this service performs the following operation:

$$R = (\text{MulValue} \times X + \text{CarryOperand}) \bmod B^{\text{RLength}}$$

**Table 43-21. Smult Service Carry Settings**

Carry Options	CarryOperand	Resulting Operation
SET_CARRYOPTION(ADD_CARRY)	CarryIn	$R = \text{MulValue} * X + \text{CarryIn}$
SET_CARRYOPTION(SUB_CARRY)	- CarryIn	$R = \text{MulValue} * X - \text{CarryIn}$
SET_CARRYOPTION(ADD_1_PLUS_CARRY)	1 + CarryIn	$R = \text{MulValue} * X + 1 + \text{CarryIn}$
SET_CARRYOPTION(ADD_1_MINUS_CARRY)	1 - CarryIn	$R = \text{MulValue} * X + 1 - \text{CarryIn}$
SET_CARRYOPTION(CARRY_NONE)	0	$R = \text{MulValue} * X$
SET_CARRYOPTION(ADD_1)	1	$R = \text{MulValue} * X + 1$
SET_CARRYOPTION(SUB_1)	-1	$R = \text{MulValue} * X - 1$
SET_CARRYOPTION(ADD_2)	2	$R = \text{MulValue} * X + 2$

### 43.3.4.7.8 Status Returned Values

**Table 43-22. Smult Service Return Codes**

Returned Status	Importance	Meaning
PUKCL_OK	–	Service functioned correctly

### 43.3.4.8 Compare

#### 43.3.4.8.1 Purpose

The purpose of this service is to compare two numbers in classical arithmetic GF(p).



**Important:** This service works only with integers.

### 43.3.4.8.2 How to Use the Service

#### 43.3.4.8.3 Description

This service accepts two numbers in classical arithmetic in input and performs a comparison, virtually subtracting  $(X + \text{CarryIn})$  from  $Y$ :

CompareGetFlags ( $Y - (X + \text{CarryIn})$ )

The numbers  $X$  and  $Y$  are untouched but the resulting flags  $\text{CarryOut}$  and the Zero Bit are filled. If the lengths of  $Y$  and  $X$  are equal, a comparison is processed.

If the length of  $Y$  is strictly greater than the length of  $X$ ,  $X$  is first virtually padded with zeros on the Most Significant Bytes side, then a comparison is processed.

**Note:** The length of  $Y$  must be greater or equal to the length of  $X$ .

In this computation, the following data need to be provided:

- $X$  (pointed by  $\{\text{nu1XBase}, \text{u2XLength}\}$ )
- $Y$  (pointed by  $\{\text{nu1YBase}, \text{u2YLength}\}$ )

The service name for this operation is `Comp`.

#### 43.3.4.8.4 Parameters Definition

**Table 43-23. Comp Service Parameters**

Parameter	Type	Direction	Location	Data Length	Before Executing the Service	After Executing the Service
Specific/Gf2n CarryIn	Bits	I	–	–	GF(2n) Bit and Carry In	–
Specific/CarryOut Zero Violation	Bits	I	–	–	–	Carry Out, Zero Bit and Violation Bit filled according to the result
nu1XBase	nu1	I	Crypto RAM	u2XLength	Base of X	Base of X
u2XLength	u2	I	–	–	Length of X	Length of X
nu1YBase	nu1	I	Crypto RAM	u2YLength	Base of Y	Base of Y
u2YLength	u2	I	–	–	Length of Y	Length of Y

#### 43.3.4.8.5 Code Example

```

PUKCL_PARAM PUKCLParam;
PPUKCL_PARAM pvPUKCLParam = &PUKCLParam;

// CarryIn shall be beforehand filled (with zero or one) PUKCL(Specific).CarryIn = ...;

// Initializing parameters
PUKCL_Comp(nu1XBase) = <Base of the ram location of X>;
PUKCL_Comp(u2XLength) = <Length of X>;
PUKCL_Comp(nu1YBase) = <Base of the ram location of Y>;
PUKCL_Comp(u2YLength) = <Length of Y>;
    
```

# SAM D5x/E5x Family Data Sheet

## Public Key Cryptography Controller (PUKCC)

```

// vPUKCL_Process() is a macro command,
// and then calls the library...
vPUKCL_Process(Comp,pvPUKCLParam);
if (PUKCL(u2Status) == PUKCL_OK)
{
    // The COMPARE has been executed correctly
    // CarryOut, Zero ... are available
    ... = PUKCL(Specific).CarryOut;
    ... = PUKCL(Specific).Zero;
}
else // Manage the error

```

### 43.3.4.8.6 Constraints

The following conditions must be avoided to ensure that the service works correctly:

- nu1XBase or nu1YBase are not aligned on 32-bit boundaries
- {nu1XBase, u2XLength} or {nu1YLength, u2YLength} are not in Crypto RAM
- u2XLength or u2YLength is either: < 4, > 0xffc or not a 32-bit length or u2XLength > u2YLength

### 43.3.4.8.7 Status Returned Values

**Table 43-24. Comp Service Return Codes**

Returned Status	Importance	Meaning
PUKCL_OK	–	Service functioned correctly

### 43.3.4.9 Full Multiply

#### 43.3.4.9.1 Purpose

The purpose of this service is to multiply two large numbers, X and Y, and optionally accumulate/subtract from a third large number, Z, returning the result, R.

The available options are as follows:

- Work in the GF(2<sup>n</sup>) field or in the standard arithmetic field
- Add of a supplemental CarryOperand
- Overlap of the operands is possible, taking into account some constraints
- Modular Reduction of the computation result (see [43.3.5.1 Modular Reduction](#))

#### 43.3.4.9.2 How to Use the Service

#### 43.3.4.9.3 Description

This service provides the following (if not computing a modular reduction of the result):

$$R = [Z] \pm (X \times Y + \text{CarryOperand})$$

Or (if computing a modular reduction of the result):

$$R = ([Z] \pm (X \times Y + \text{CarryOperand})) \bmod N$$

The service name for this operation is `Fmult`.

In these computations, the following data has to be provided:

- R the result (pointed by {nu1RBase,u2Xlength +u2YLength})
- X one input number or GF(2<sup>n</sup>) polynomial (pointed by{nu1XBase,u2XLength})
- Y one input number or GF(2<sup>n</sup>) polynomial (pointed by{nu1YBase,u2YLength})
- Z one optional input number or GF(2<sup>n</sup>) polynomial (pointed by {nu1ZBase,u2Xlength +u2YLength})



# SAM D5x/E5x Family Data Sheet

## Public Key Cryptography Controller (PUKCC)

- CarryOperand (provided through the Carry Options and Carry values)



**Important:** Even if neither accumulation nor subtraction is specified, the nu1ZBase must always be filled and point to a Crypto RAM space. In this case, nu1ZBase can point to the same space as the nu1RBase.

If using the big modular reduction option, the Multiply operation is followed by a reduction (see [43.3.5.1 Modular Reduction](#)). In this case, the length of Cns is 64 bytes.

If using the modular reduction option, the Multiply operation is followed by a reduction (see [43.3.5.1 Modular Reduction](#)). In this case the following parameters must be additionally provided:

- N—the modulus (pointed by {nu1ModBase,u2Modlength +4})
- Cns—the reduction constant
  - In case of Big reduction, Cns is pointed by {nu1CnsBase,64bytes}.
  - In case of Fast or Normalized reduction, Cns is pointed by (pointed by {nu1CnsBase,u2ModLength+ 8})

**Note:**

The result buffer R must first be padded with zero bytes until its length is sufficient to perform the reduction ( $2 * u2ModLength + 8$ ) to be used by the Modular Reduction service as an input parameter.

The result of the reduction is written in the area X pointed by {nu1XBase, u2ModLength + 4}.

For example, if u2ModLength, u2XLength and u2YLength are 0x80 bytes, the length of the R space is  $2 * (u2ModLength + 4) = 0x108$  bytes because of the constraints of modular reduction.

In case of Fast or Normalized Reduction, the length of the result is u2ModLength + 4 so 0x84 bytes. Thus, the zone X has a length of 0x84 bytes (at least). The multiplication of X by Y provides a result of length 0x100 bytes in the zone R so the 8 MSB bytes must be previously padded with zero bytes (in offsets 0x100 to 0x107).

#### 43.3.4.9.4 Parameters Definition

**Table 43-25. Fmult Service Parameters**

Parameter	Type	Direction	Location	Data Length	Before Executing the Service	After Executing the Service
u2Options	u2	I	–	–	Options (see below)	Options (see below)
Specific/Gf2n CarryIn	Bits	I	–	–	GF(2n) Bit and Carry In	–
Specific/ CarryOut Zero Violation	Bits	I	–	–	–	Carry Out, Zero Bit and Violation Bit filled according to the result
nu1ModBase	nu1	I	Crypto RAM	u2ModLength + 4	Base of N	Base of N untouched

# SAM D5x/E5x Family Data Sheet

## Public Key Cryptography Controller (PUKCC)

.....continued

Parameter	Type	Direction	Location	Data Length	Before Executing the Service	After Executing the Service
nu1CnsBase	nu1	I	Crypto RAM	u2ModLength + 8 or 64 bytes	Base of Cns	Base of Cns untouched
u2ModLength	u2	I	–	–	Length of N	Length of N
nu1XBase	nu1	I	Crypto RAM	u2XLength or u2ModLength + 4 (see <b>Note 1</b> )	Base of X	Base of X (see <b>Note 2</b> )
u2XLength	u2	I	–	–	Length of X	Length of X
nu1YBase	nu1	I	Crypto RAM	u2YLength	Base of Y	Base of Y
u2YLength	u2	I	–	–	Length of Y	Length of Y
nu1ZBase	nu1	I	Crypto RAM	u2XLength + u2YLength	Base of Z	Base of Z untouched
nu1RBase	nu1	I	Crypto RAM	u2XLength + u2YLength	Base of R	Base of R (see <b>Note 3</b> )

**Note:**

1. In case of a reduction option is specified, if necessary, the area X will be extended to u2ModLength + 4 bytes.
2. If FMult is without reduction, X is untouched. If FMult is with reduction, X is filled with the final result.
3. If FMult is without reduction, R is filled with the final result. If FMult is with reduction, R is corrupted.

### 43.3.4.9.5 Available Options

The options are set by the u2Options input parameter, which is composed of:

- the mandatory Full Multiplication operation option described in [Table 43-26](#)
- the mandatory CarryOperand option described in [Table 43-27](#) and [Table 43-28](#)
- the facultative Modular Reduction option (see [43.3.5.1 Modular Reduction](#)). If the Modular Reduction is not requested, this option is absent.

The u2Options number is calculated by an Inclusive OR of the options.

Some Examples in C language are:

- Operation: Full Multiply only without carry and without Modular Reduction  

```
PUKCL(u2Options) = SET_MULTIPLIEROPTION(PUKCL_FMULT_ONLY) |
SET_CARRYOPTION(CARRY_NONE);
```
- Operation: Full Multiply with addition with Specific/CarryIn addition and with Fast Modular Reduction  

```
PUKCL(u2Options) = SET_MULTIPLIEROPTION(PUKCL_FMULT_ADD) |
SET_CARRYOPTION(ADD_CARRY) |
PUKCL_REDMOD_REDUCTION |
PUKCL_REDMOD_USING_FASTRED;
```

# SAM D5x/E5x Family Data Sheet

## Public Key Cryptography Controller (PUKCC)

The following table shows all of the necessary parameters for the Full Multiply option. When the Addition or Subtraction option is not chosen, it is not necessary to fill in the nu1ZBase parameter.

**Table 43-26. Fmult Service Options**

Option	Purpose	Required Parameters
SET_MULTIPLIEROPTION(PUKCL_FMUL_ONLY)	Perform $R = X*Y + \text{CarryOperand}$	nu1RBase, nu1YBase, u2YLength, nu1XBase, u2XLength
SET_MULTIPLIEROPTION(PUKCL_FMUL_ADD)	Perform $R = Z + X*Y + \text{CarryOperand}$	nu1RBase, nu1ZBase, nu1YBase, u2YLength, nu1XBase, u2XLength
SET_MULTIPLIEROPTION(PUKCL_FMUL_SUB)	Perform $R = Z - (X*Y + \text{CarryOperand})$	nu1RBase, nu1ZBase, nu1YBase, u2YLength, nu1Xlength, u2XLength

### 43.3.4.9.6 Code Example

```

PUKCL_PARAM PUKCLParam;
PUPUKCL_PARAM pvPUKCLParam = &PUKCLParam;

// Gf2n and CarryIn shall be beforehand filled (with zero or one)
PUKCL(Specific).Gf2n = ...;
PUKCL(Specific).CarryIn = ...;

PUKCL(u2Option) = ...;
// Depending on the option specified, not all fields should be filled
PUKCL_Fmult(nu1XBase) = <Base of the ram location of X>;
PUKCL_Fmult(u2XLength) = <Length of X>;
PUKCL_Fmult(nu1YBase) = <Base of the ram location of Y>;
PUKCL_Fmult(u2YLength) = <Length of Y>;
PUKCL_Fmult(nu1ZBase) = <Base of the ram location of Z>;
PUKCL_Fmult(nu1RBase) = <Base of the ram location of R>;

// vPUKCL_Process() is a macro command, which populates the service name
// and then calls the library...
vPUKCL_Process(Fmult, pvPUKCLParam);
if (PUKCL(u2Status) == PUKCL_OK)
{
    // The Full multiply has been executed correctly
    ...
}
else // Manage the error

```

# SAM D5x/E5x Family Data Sheet

## Public Key Cryptography Controller (PUKCC)

### 43.3.4.9.7 Important Considerations for Modular Reduction of a Fmult Computation Result

**Note:**

Additional options are available through the use of a modular reduction to be executed at the end of this operation. Some important considerations have to be taken into account concerning the length of resulting operands to get a mathematically correct result.

The output of this operation is not always compatible with the modular reduction as it may be either smaller or bigger. In the case (most of the time) the result (pointed by nu1RBase) is smaller in size than “twice the modulus plus one word” by one word, a padding word must be added to zero. Otherwise, the reduced value will be taken considering the high order words (potentially uninitialized) as part of the number, thus resulting in getting a mathematically correct but unexpected result.

In the case that the result is bigger than twice the modulus plus one word, the modular reduction feature has to be executed as a separate operation, using an Euclidean division.

### 43.3.4.9.8 Constraints

The following conditions must be avoided to ensure that the service works correctly:

- nu1XBase, nu1YBase, nu1RBase or nu1ZBase are not aligned on 32-bit boundaries
- {nu1XBase, u2XLength}, {nu1YLength, u2YLength}, {nu1ZBase, u2XLength+u2YLength} or {nu1RBase, u2XLength+u2YLength} are not in Crypto RAM
- u2XLength, u2YLength is either: < 4, > 0xffc or not a 32-bit length
- {nu1RBase, u2XLength+u2YLength} overlaps {nu1YBase, u2YLength} or {nu1RBase, u2XLength+u2YLength} overlaps {nu1XBase, u2XLength}
- {nu1RBase, u2XLength+u2YLength} overlaps {nu1ZBase, u2XLength+u2YLength} and nu1RBase > nu1ZBase

If a modular reduction is specified, the relevant parameters must be defined according to the chosen reduction and follow the description in [43.3.5.1 Modular Reduction](#). Additional constraints to be respected and error codes are described in this section and in [Table 43-49](#).

**Multiplication with Accumulation or Subtraction**

In the case where the options bits specify that either an Accumulation or a subtraction should be performed, this service performs the following operation:

$$R = (Z \pm (X \times Y + CarryOperand)) \bmod B^{XLength + YLength}$$

**Table 43-27. Fmult Service (with Accumulate/Subtract From) Carry Settings**

Option AND CARRYOPTIONS	CarryOperand	Resulting Operation
SET_CARRYOPTION(ADD_CARRY)	CarryIn	$R = Z \pm (X*Y + CarryIn)$
SET_CARRYOPTION(SUB_CARRY)	- CarryIn	$R = Z \pm (X*Y - CarryIn)$
SET_CARRYOPTION(ADD_1_PLUS_CARRY)	1 + CarryIn	$R = Z \pm (X*Y + 1 + CarryIn)$
SET_CARRYOPTION(ADD_1_MINUS_CARRY)	1 - CarryIn	$R = Z \pm (X*Y + 1 - CarryIn)$
SET_CARRYOPTION(CARRY_NONE)	0	$R = Z \pm (X*Y)$
SET_CARRYOPTION(ADD_1)	1	$R = Z \pm (X*Y + 1)$
SET_CARRYOPTION(SUB_1)	- 1	$R = Z \pm (X*Y - 1)$
SET_CARRYOPTION(ADD_2)	2	$R = Z \pm (X*Y + 2)$

# SAM D5x/E5x Family Data Sheet

## Public Key Cryptography Controller (PUKCC)

### **Multiplication without Accumulation or Subtraction**

In the case the options bits specify that either an Accumulation or a subtraction should be performed, this service performs the following operation:

$$R = (X \times Y + \text{CarryOperand}) \bmod B^{X\text{Length} + Y\text{Length}}$$

**Table 43-28. Fmult Service Carry Settings**

Option AND CARRYOPTIONS	CarryOperand	Resulting Operation
SET_CARRYOPTION(ADD_CARRY)	CarryIn	$R = X*Y + \text{CarryIn}$
SET_CARRYOPTION(SUB_CARRY)	- CarryIn	$R = X*Y - \text{CarryIn}$
SET_CARRYOPTION(ADD_1_PLUS_CARRY)	1 + CarryIn	$R = X*Y + 1 + \text{CarryIn}$
SET_CARRYOPTION(ADD_1_MINUS_CARRY)	1 - CarryIn	$R = X*Y + 1 - \text{CarryIn}$
SET_CARRYOPTION(CARRY_NONE)	0	$R = X*Y$
SET_CARRYOPTION(ADD_1)	1	$R = X*Y + 1$
SET_CARRYOPTION(SUB_1)	- 1	$R = X*Y - 1$
SET_CARRYOPTION(ADD_2)	2	$R = X*Y + 2$

#### 43.3.4.9.9 Status Returned Values

**Table 43-29. Fmult Service Return Codes**

Returned Status	Importance	Meaning
PUKCL_OK	–	Service functioned correctly

#### 43.3.4.10 Square

##### 43.3.4.10.1 Purpose

The purpose of this service is to compute the square of a big number and optionally accumulate/subtract from a second big number.

Please note that this service uses an optimized implementation of the squaring. It also means that when the GF(2<sup>n</sup>) flag is set, the execution time will be smaller than when not set (in that case, the squaring execution time will still be smaller than for a standard multiplication).

The available options are as follows:

- Work in the GF(2<sup>n</sup>) or in the standard integer arithmetic field
- Add of a supplemental CarryOperand
- Overlapping of the operands is possible, taking into account some constraints
- Modular Reduction of the computation result

##### 43.3.4.10.2 How to Use the Service

##### 43.3.4.10.3 Description

This service provides the following (if not computing a modular reduction of the result):

$$R = [Z] \pm (X^2 + \text{CarryOperand})$$

Or (if computing a modular reduction of the result):

$$R = ([Z] \pm (X^2 + \text{CarryOperand})) \bmod N$$

# SAM D5x/E5x Family Data Sheet

## Public Key Cryptography Controller (PUKCC)

The service name for this operation is `Square`.

In these computations, the following data has to be provided:

- R the result (pointed by  $\{\text{nu1RBase}, 2 * \text{u2Xlength}\}$ )
- X one input number or GF(2n) polynomial (pointed by  $\{\text{nu1XBase}, \text{u2XLength}\}$ )
- Z one optional input number or GF(2n) polynomial (pointed by  $\{\text{nu1ZBase}, 2 * \text{u2Xlength}\}$ )
- CarryOperand (provided through the CarryOptions and Carry values)



**Important:** Even if neither accumulation nor subtraction is specified, the `nu1ZBase` must always be filled and point to a Crypto RAM space. In this case, `nu1ZBase` can point to the same space as the `nu1RBase`.

If using the big modular reduction option, the Multiply operation is followed by a reduction (see [43.3.5.1 Modular Reduction](#)). In this case, the length of `Cns` is 64 bytes.

If using the modular reduction option the Square operation is followed by a reduction (see [43.3.5.1 Modular Reduction](#)). In this case the following parameters must be additionally provided:

- N—the modulus (pointed by  $\{\text{nu1ModBase}, \text{u2Modlength} + 4\}$ ).
- `Cns`—the reduction constant (pointed by  $\{\text{nu1CnsBase}, \text{u2Modlength} + 8\}$ )
  - In case of big reduction option, the length of `Cns` is 64bytes.

**Note:**

The result buffer R must first be padded with zero bytes until its length is sufficient to perform the reduction ( $2 * \text{u2ModLength} + 8$ ) to be used by the Modular Reduction service as an input parameter.

The result of the reduction is written in the area X pointed by  $\{\text{nu1XBase}, \text{u2ModLength} + 4\}$ .

For example, if `u2ModLength`, `u2XLength` is 0x80 bytes, the length of the R space is  $2 * (\text{u2ModLength} + 4) = 0x108$  bytes because of the constraints of modular reduction.

In case of Fast or Normalized Reduction, the length of the result is `u2ModLength + 4` so 0x84 bytes. Thus, the zoneX has a length of 0x84 bytes (at least). The square of X provides a result of length 0x100 bytes in the zone R so the 8 MSB bytes previously must be previously padded with zero bytes (in offsets 0x100 to 0x107).

#### 43.3.4.10.4 Parameters Definition

**Table 43-30. Square Service Parameters**

Parameter	Type	Direction	Location	Data Length	Before Executing the Service	After Executing the Service
<code>u2Options</code>	u2	I	–	–	Options (see below)	Options (see below)
<code>Specific/Gf2n CarryIn</code>	Bits	I	–	–	GF(2n) Bit and Carry In	–

# SAM D5x/E5x Family Data Sheet

## Public Key Cryptography Controller (PUKCC)

.....continued

Parameter	Type	Direction	Location	Data Length	Before Executing the Service	After Executing the Service
Specific/ CarryOut Zero Violation	Bits	I	–	–	–	Carry Out, Zero Bit and Violation Bit filled according to the result
nu1ModBase	nu1	I	Crypto RAM	u2ModLength + 4	Base of N	Base of N untouched
nu1CnsBase	nu1	I	Crypto RAM	u2ModLength + 8 or 64 bytes	Base of Cns	Base of Cns untouched
u2ModLength	u2	I	–	–	Length of N	Length of N
nu1XBase	nu1	I	Crypto RAM	u2XLength or u2ModLength + 4 (see <b>Note 1</b> )	Base of X	Base of X ( see <b>Note 2</b> )
u2XLength	u2	I	–	–	Length of X	Length of X
nu1ZBase	nu1	I	Crypto RAM	2 * u2XLength	Base of Z	Base of Z
nu1RBase	nu1	I	Crypto RAM	2 * u2XLength	Base of R	Base of R (see <b>Note 3</b> )

**Note:**

1. In case of a reduction option is specified, the area X will be, if necessary, extended to u2ModLength + 4 bytes.
2. If Square is without reduction, X is untouched. If Square is with reduction, X is filled with the final result.
3. If Square is without reduction, R is filled with the final result. If Square is with reduction, R is corrupted.

**43.3.4.10.5 Available Options**

The options are set by the u2Options input parameter, which is composed of:

- the mandatory Square operation option described in [Table 43-31](#)
- the mandatory CarryOperand option described in [Table 43-32](#) and [Table 43-33](#)
- the facultative Modular Reduction option (see [43.3.5.1 Modular Reduction](#)). If the Modular Reduction is not requested, this option is absent.

The u2Options number is calculated by an Inclusive OR of the options. Some Examples in C language are:

- Operation: Square only without carry and without Modular Reduction  

```
PUKCL(u2Options) = SET_MULTIPLIEROPTION(PUKCL_SQUARE_ONLY) | SET_CARRYOPTION(CARRY_NONE);
```
- Operation: Square with addition with Specific/CarryIn addition and with Fast Modular Reduction

# SAM D5x/E5x Family Data Sheet

## Public Key Cryptography Controller (PUKCC)

```

PUKCL(u2Options) = SET_MULTIPLIEROPTION(PUKCL_SQUARE_ADD) |
SET_CARRYOPTION(ADD_CARRY) | PUKCL_REDMOD_REDUCTION |
PUKCL_REDMOD_USING_FASTRED;

```

The following table lists all of the necessary parameters for the Square option. When the Addition or Subtraction option is not chosen it is not necessary to fill in the nu1ZBase parameter.

**Table 43-31. Square Service Options**

Option	Purpose	Required Parameters
SET_MULTIPLIEROPTION(PUKCL_SQUARE_ONLY)	Perform $R = X^2 + \text{CarryOperand}$	nu1RBase, nu1ZBase, nu1XBase, u2XLength
SET_MULTIPLIEROPTION(PUKCL_SQUARE_ADD)	Perform $R = Z + X^2 + \text{CarryOperand}$	nu1RBase, nu1ZBase, nu1XBase, u2XLength
SET_MULTIPLIEROPTION(PUKCL_SQUARE_SUB)	Perform $R = Z - (X^2 + \text{CarryOperand})$	nu1RBase, nu1ZBase, nu1Xlength, u2XLength

### 43.3.4.10.6 Code Example

```

PUKCL_PARAM PUKCLParam;
PPUKCL_PARAM pvPUKCLParam = &PUKCLParam;

// Gf2n and CarryIn shall be beforehand filled (with zero or one)
PUKCL(Specific).Gf2n = ...;
PUKCL(Specific).CarryIn = ...;

PUKCL(u2Option) = ...;
// Depending on the option specified, not all fields should be filled
PUKCL_Fmult(nu1XBase) = <Base of the ram location of X>;
PUKCL_Fmult(u2XLength) = <Length of X>;
PUKCL_Fmult(nu1ZBase) = <Base of the ram location of Z>;

// vPUKCL_Process() is a macro command, which populates the service name
// and then calls the library...
vPUKCL_Process(Square, pvPUKCLParam);
if (PUKCL(u2Status) == PUKCL_OK)
{
    // The Squaring has been executed correctly
    ...
}
else // Manage the error

```

### 43.3.4.10.7 Important Considerations for Modular Reduction of a Square Computation

**Note:**

Additional options are available through the use of a modular reduction to be executed at the end of this operation. Some important considerations have to be taken into account concerning the length of resulting operands to get a mathematically correct result.

The output of this operation is not obviously compatible with the modular reduction as it may be either smaller or bigger. In the case (most of the time) the result (pointed by nu1RBase) is smaller in size than “twice the modulus plus one word” by one word, a padding word must be added to zero. Otherwise, the reduced value will be taken considering the high order words (potentially uninitialized) as part of the number, thus resulting in getting a mathematically correct but unexpected result.

In the case that the result is greater than twice the modulus plus one word, the modular reduction feature has to be executed as a separate operation, using an Euclidean division.



# SAM D5x/E5x Family Data Sheet

## Public Key Cryptography Controller (PUKCC)

### 43.3.4.10.8 Constraints

When the options only indicate a square, the constraints involving nu1ZBase are not checked. The following conditions must be avoided to ensure that the service works correctly:

- nu1XBase, nu1RBase or nu1ZBase are not aligned on 32-bit boundaries
- {nu1XBase, u2XLength}, {nu1ZBase, 2\*u2XLength} or {nu1RBase, 2\*u2XLength} are not in Crypto RAM
- u2XLength is either: < 4, > 0xffc or not a 32-bit length
- {nu1RBase, 2\*u2XLength} overlaps {nu1XBase, u2XLength}
- {nu1RBase, 2\*u2XLength} overlaps {nu1ZBase, 2\*u2XLength} and nu1RBase > nu1ZBase

If a modular reduction is specified, the relevant parameters must be defined according to the chosen reduction and follow the description in [43.3.5.1 Modular Reduction](#). Additional constraints to be respected and error codes are described in this section and in [Table 43-49](#).

#### **Multiplication with Accumulation or Subtraction**

Where the options bits specify that either an Accumulation or a subtraction should be performed, this command performs the following operation:

$$R = (Z \pm (X^2 + CarryOperand)) \bmod B^{2 \times XLength}$$

**Table 43-32. Multiplication with Accumulation or Subtraction**

Option AND CARRYOPTIONS	CarryOperand	Resulting Operation
SET_CARRYOPTION(ADD_CARRY)	CarryIn	$R = Z \pm (X^2 + CarryIn)$
SET_CARRYOPTION(SUB_CARRY)	- CarryIn	$R = Z \pm (X^2 - CarryIn)$
SET_CARRYOPTION(ADD_1_PLUS_CARRY)	1 + CarryIn	$R = Z \pm (X^2 + 1 + CarryIn)$
SET_CARRYOPTION(ADD_1_MINUS_CARRY)	1 - CarryIn	$R = Z \pm (X^2 + 1 - CarryIn)$
SET_CARRYOPTION(CARRY_NONE)	0	$R = Z \pm (X^2)$
SET_CARRYOPTION(ADD_1)	1	$R = Z \pm (X^2 + 1)$
SET_CARRYOPTION(SUB_1)	- 1	$R = Z \pm (X^2 - 1)$
SET_CARRYOPTION(ADD_2)	2	$R = Z \pm (X^2 + 2)$

### 43.3.4.10.9 Multiplication without Accumulation or Subtraction

Where the options bits specify that either an accumulation or a subtraction should be performed, this command performs the following operation:

$$R = (X^2 + CarryOperand) \bmod B^{2 \times XLength}$$

**Table 43-33. Square Service Carry Settings**

Option AND CARRYOPTIONS	CarryOperand	Resulting Operation
SET_CARRYOPTION(ADD_CARRY)	CarryIn	$R = X^2 + CarryIn$
SET_CARRYOPTION(SUB_CARRY)	- CarryIn	$R = X^2 - CarryIn$
SET_CARRYOPTION(ADD_1_PLUS_CARRY)	1 + CarryIn	$R = X^2 + 1 + CarryIn$
SET_CARRYOPTION(ADD_1_MINUS_CARRY)	1 - CarryIn	$R = X^2 + 1 - CarryIn$
SET_CARRYOPTION(CARRY_NONE)	0	$R = X^2$

# SAM D5x/E5x Family Data Sheet

## Public Key Cryptography Controller (PUKCC)

.....continued

Option AND CARRYOPTIONS	CarryOperand	Resulting Operation
SET_CARRYOPTION(ADD_1)	1	$R = X^2 + 1$
SET_CARRYOPTION(SUB_1)	- 1	$R = X^2 - 1$
SET_CARRYOPTION(ADD_2)	2	$R = X^2 + 2$

### 43.3.4.10.10 Status Returned Values

**Table 43-34. Square Service Return Codes**

Returned status	Importance	Meaning
PUKCL_OK	–	Service functioned correctly

### 43.3.4.11 Integral (Euclidean) Division

#### 43.3.4.11.1 Purpose

The purpose of this service is to compute the Euclidean Division of two multiple precision numbers in GF(p) or polynomial in GF(2<sup>n</sup>). The Numerator is divided by the Denominator giving the Quotient “Quo” and the Remainder “R”.

The following options are available:

- Work in the GF(2<sup>n</sup>) field or in the standard integer arithmetic field GF(p)

#### 43.3.4.11.2 How to Use the Service

#### 43.3.4.11.3 Description

This service processes the calculus corresponding to:

$$Num = Mod \times Quo + R \text{ with } 0 \leq R < Mod \text{ and } Quo = \left\lfloor \frac{Num}{Mod} \right\rfloor$$

The Numerator is Num.

The Divisor (Modulus) is Mod.

The Quotient is Quo.

The Remainder is R.

The Inputs are, the Numerator Num, and the Denominator Mod. The service calculates the Quotient and the Remainder. The Remainder overwrites the Numerator and is copied to the R area.

If the parameter nu1QuoBase equals zero, the Quotient is not stored in memory.

If nu1QuoBase is different from zero, the Quotient length is (<Numerator Length> - <Denominator Length>) + 4 bytes.

In this computation, the following areas need to be provided:

- Num (pointed by {nu1NumBase,u2NumLength}) filled with the Numerator (with MSB word to zero).
- Mod (pointed by {nu1ModBase,u2ModLength}) filled with the Denominator.
- Workspace (pointed by {nu1CnsBase,64 or68}).
- Quo (pointed by {nu1QuoBase,u2NumLength - u2ModLength + 4}) to contain calculated Quotient.
  - When the quotient is not needed, the nu1QuoBase pointer can be provided as NULL. In that case, only the remainder will be provided as a result.

# SAM D5x/E5x Family Data Sheet

## Public Key Cryptography Controller (PUKCC)

- R (pointed by {nu1RBase,u2ModLength}) to contain the calculated Remainder.

The service name for this operation is `Div`.

### 43.3.4.11.4 Parameters Definition

**Table 43-35. Div Service Parameters**

Parameter	Type	Dir.	Location	Data Length	Before Executing the Service	After Executing the Service
Specific/Gf2n	Bit	I	–	–	GF(2n) Bit	–
nu1NumBase	nu1	I	Crypto RAM	u2NumLength	Base of Num Filled with the Numerator	Base of Num Filled with the Remainder
u2NumLength	u2	I	–	–	Length of the Numerator	Length of the Numerator
nu1ModBase	nu1	I	Crypto RAM	u2ModLengt	Base of the Divisor	Base of the Divisor untouched
u2ModLength	u2	I	–	–	Length of the Divisor	Length of the Divisor
nu1QuoBase (see <b>Note 1</b> )	nu1	I	Crypto RAM	u2NumLength - u2ModLength + 4	Base of the Quotient	Base of the Quotient
nu1WorkSpace	nu1	I	Crypto RAM	GF(p): 64 GF(2n): 68	Base of the WorkSpace	Base of the WorkSpace corrupted
nu1RBase ( see <b>Note 2</b> )	nu1	I	Crypto RAM	u2ModLength	Base of the Remainder	Base of the Remainder

**Note:**

1. If the quotient is not needed, set nu1QuoBase to zero and the quotient will not be written to memory. If the quotient is needed, set the nu1QuoBase to the beginning of an area of size (u2NumLength - u2ModLength + 4) to write the whole quotient.
2. The Remainder is present in the area {nu1NumBase, u2NumLength} at the end of the calculus. The nu1RBase parameter makes it possible to copy this result in the other area {nu1RBase, u2ModLength}, if this copy is not needed, set nu1RBase to the same value as nu1NumBase and the copy will not be done.

# SAM D5x/E5x Family Data Sheet

## Public Key Cryptography Controller (PUKCC)

**Note:** The parameter Num must have its most significant 32-bit word cleared to zero. The length u2NumLength is the length of Num including this zero word.

One additional word is used on the LSB side of the Num parameter, this word is restored at the end of the calculus. As a consequence the parameter nu1NumBase must never be at the beginning of the Crypto RAM, i.e., ensure that  $\text{nu1NumBase} \geq \langle \text{Crypto RAM Base} \rangle + 4$  bytes.

One additional word is used on the MSB side of the Num parameter, this word is not corrupted. As a consequence the Area {nu1NumBase, u2NumLength} must not be at the end of the Crypto RAM, i.e., ensure that  $\text{nu1NumBase} + \text{u2NumLength} \leq \langle \text{Crypto RAM End} \rangle - 4$ .

u2ModLength must be the true length of the Modulus, i.e., the MSB word of the area {nu1ModBase, u2ModLength} must be different from zero.

The minimum value for u2ModLength is 8 bytes, so the significant length of Num must be at least 8 bytes. To divide by a 32-bit value, the divider and numerator shall be multiplied by 232. The resulting remainder will have to be divided by  $2^{32}$ , the quotient will be exact.

### 43.3.4.11.5 Code Example

```
PUKCL_PARAM PUKCLParam;
P_PUKCL_PARAM pvPUKCLParam = &PUKCLParam;

// Fill all the fields
// In that case, the quotient will be computed
// If it was not needed, set nulQuoBase to NULL
PUKCL_Div(nulNumBase) = <Base of the ram location of Num>;
PUKCL_Div(nulModBase) = <Base of the ram location of Mod>;
PUKCL_Div(nulQuoBase) = <Base of the ram location of Quo>;
PUKCL_Div(nulWorkSpace) = <Base of the workspace>;
PUKCL_Div(nulRBase) = <Base of the ram location of R>;
PUKCL_Div(u2NumLength) = <Length of Num>;
PUKCL_Div(u2ModLength) = <Length of Mod>;

// vPUKCL_Process() is a macro command, which populates the service name
// and then calls the library...
vPUKCL_Process(Div, pvPUKCLParam);
if (PUKCL(u2Status) == PUKCL_OK)
{
    // The Division has been executed correctly
    ...
}
else // Manage the error
```

### 43.3.4.11.6 Constraints

The following conditions must be avoided to ensure the service works correctly:

- nu1ModBase, nu1RBase, nu1QuoBase, nu1WorkSpace or nu1NumBase are not aligned on 32-bit boundaries
- {nu1ModBase, u2ModLength}, {nu1RBase, u2ModLength}, {nu1WorkSpace, 64} or {nu1NumBase, u2NumLength} are not in Crypto RAM
- u2ModLength, u2NumLength is either:  $< 4$ ,  $> 0\text{xffc}$  or not a 32-bit length
- One or more overlaps exist between two of the areas: {nu1ModBase, u2ModLength}, {nu1RBase, u2ModLength} {nu1NumBase, u2NumLength}(1) or {nu1WorkSpace, 64}
- If nu1QuoBase is different from zero and: {nu1QuoBase, u2NumLength - u2ModLength + 4} are not in Crypto RAM
- If nu1QuoBase is different from zero and one or more overlaps exist between two of the areas: {nu1QuoBase, u2NumLength - u2ModLength + 4}, {nu1ModBase, u2ModLength}, {nu1RBase, u2ModLength}, {nu1NumBase, u2NumLength} or {nu1WorkSpace, 64}

Overlaps between {nu1RBase, u2ModLength} and {nu1NumBase, u2NumLength} are forbidden, but the equality between nu1RBase and nu1NumBase is authorized

### 43.3.4.11.7 Status Returned Values

**Table 43-36. Div Service Return Codes**

Returned Status	Importance	Meaning
PUKCL_OK	–	Service functioned correctly.
PUKCL_DIVISION_BY_ZERO	Severe	The operation was not performed because the Denominator value is zero.

### 43.3.4.12 GCD, Modular Inverse

#### 43.3.4.12.1 Purpose

The purpose of this command is to compute the Greatest Common Divisor (GCD) and the Modular Inverse. The algorithm used is the Extended Euclidean Algorithm for the GCD.

This command accepts as input two multiple precision numbers in GF(p) or two polynomials in GF(2<sup>n</sup>) X and Y and computes their GCD (D), if D equals one, the command also supplies the inverse of X modulo Y.

The available options are as follows:

- Work in the GF(2<sup>n</sup>) field or in the standard integer arithmetic field GF(p)

#### 43.3.4.12.2 How to Use the Service

#### 43.3.4.12.3 Description

This command calculates:

$$D = GCD(X, Y).$$

and parameter A in the Bezout equation:

$$A \times X + B \times Y = D.$$

The first input, or input to inverse is X.

The second input, or modulus is Y.

The GCD is output in D.

The modular inverse if X and Y are co-primes is output A:

$$A = X^{-1} \text{mod}(Y)$$

The command calculates the GCD and the value A. The value A is the multiplicative inverse of X, only if X and Y are co-prime. As a supplemental result, Z is given back, being the quotient of Y divided by D only if D is different from zero:

$$Z = \left\lfloor \frac{Y}{D} \right\rfloor$$

At the end of the command: X is overwritten by D.

Y is cleared.

The value of A is calculated and stored.

The value of Z is calculated and stored if D is different from zero.

The service name for this operation is GCD.

In this computation, the following areas have to be provided:

# SAM D5x/E5x Family Data Sheet

## Public Key Cryptography Controller (PUKCC)

- X (pointed by {nu1XBase,u2Length}) filled with X (with MSB word to zero)
- Y (pointed by {nu1YBase,u2Length}) filled with Y (with MSB word to zero)
- A (pointed by {nu1ABase,u2Length}) to contain calculated A
- Z (pointed by {nu1ZBase,u2Length}) to contain calculated Z
- The workspace (pointed by {nu1WorkSpace,32})

### 43.3.4.12.4 Parameters Definition

**Table 43-37. GCD Service Parameters**

Parameter	Type	Dir.	Location	Data Length	Before Executing the Service	After Executing the Service
Specific/Gf2n	Bit	I	–	–	GF(2n) Bit	–
nu1XBase	nu1	I	Crypto RAM	u2Length	Base of X Number X	Base of X Filled with the GCD D
u2Length	u2	I	–	–	Length of the Areas X, Y, A, Z	Length of the Areas X, Y, A, Z
nu1YBase	nu1	I	Crypto RAM	u2Length	Base of Y Number Y	Base of Y Cleared area
nu1ABase	nu1	I	Crypto RAM	u2Length	Base of A	Base of A Filled with the result
nu1ZBase	nu1	I	Crypto RAM	u2Length + 4 (see <b>Note 1</b> )	Base of Z	Base of Z Filled with the result
nu1WorkSpace	nu1	I	Crypto RAM	32 bytes	Base of the workspace	Base of the workspace corrupted

**Note:**

1. The additional word is 4 zero bytes.

The parameters X and Y must have their most significant 32-bit word cleared to zero. The length u2Length is the length of the longer of the parameters X and Y including this zero word.

To clarify here is an example:

- X is an 8 bytes number.
- Y is a 12 bytes number.

This example is processed this way before the use of the GCD service:

- The longer number is Y so its length is taken and increased by 4 bytes for the 32-bit word cleared to zero, this gives u2Length = 16 bytes. Therefore, X, Y, A and Z areas have a length of 16 bytes.
- Y is padded with 4 bytes cleared to zero on the MSB side and the u2Length = 16 bytes are written in memory (LSB first).
- X is padded with 8 bytes cleared to zero on the MSB side and the u2Length = 16 bytes are written in memory (LSB first).
- The areas A and Z are mapped in memory with a size of u2Length = 16 bytes.
- The workspace is mapped in memory with its constant size of 32 bytes

### 43.3.4.12.5 Code Example

```

PUKCL_PARAM PUKCLParam;
PPUKCL_PARAM pvPUKCLParam = &PUKCLParam;
// Fill all the fields
PUKCL(u2Option) = 0;
PUKCL_GCD(nu1XBase) = <Base of the ram location of X>;
PUKCL_GCD(nu1YBase) = <Base of the ram location of Y>;
PUKCL_GCD(nu1ABase) = <Base of the ram location of A>;
PUKCL_GCD(nu1ZBase) = <Base of the ram location of Z>;
PUKCL_GCD(nu1WorkSpace) = <Base of the workspace>;
PUKCL_GCD(u2Length) = <Length of X, Y, A and Z>;
// vPUKCL_Process() is a macro command, which populates the service name
// and then calls the library...
vPUKCL_Process(GCD, pvPUKCLParam);
if (PUKCL_Param.Status == PUKCL_OK)
    {
        // The GCD has been executed correctly
        ...
    }
else // Manage the error

```

### 43.3.4.12.6 Constraints

The following conditions must be avoided to ensure that the service works correctly:

- nu1XBase, nu1YBase, nu1ABase or nu1ZBase are not aligned on 32-bit boundaries
- {nu1XBase, u2Length}, {nu1YBase, u2Length}, {nu1ABase, u2Length} or {nu1ZBase, u2Length} are not in Crypto RAM
- u2Length is either: < 4, > 0xffc or not a 32-bit length
- {nu1XBase, u2Length} overlaps {nu1YBase, u2Length} or {nu1XBase, u2Length} overlaps {nu1ABase, u2Length} or {nu1XBase, u2Length} overlaps {nu1ZBase, u2Length} or {nu1YBase, u2Length} overlaps

{nu1ABase, u2Length} or {nu1YBase, u2Length} overlaps {nu1ZBase, u2Length} or {nu1ABase, u2Length} overlaps {nu1ZBase, u2Length}

### 43.3.4.12.7 Status Returned Values

**Table 43-38. GCD Service Return Codes**

Returned Status	Importance	Meaning
PUKCL_OK	–	Service functioned correctly

### 43.3.4.13 Get Random Number

#### 43.3.4.13.1 Purpose

The purpose of this command is to provide the user with a source of entropy. The options available for this service are:

- Generation of random numbers from a Hardware Random Number Generator (TRNG).
- Generation of random numbers from a Deterministic Random Number Generator (DRNG).

# SAM D5x/E5x Family Data Sheet

## Public Key Cryptography Controller (PUKCC)



### Important:

When using this service, be sure to strictly follow the directives given for the RNG on the chip you use (particularly initialization, seeding) and compulsorily start the RNG. If the directives require not to use this service, follow them and use the proposed method to get random numbers.

This service only has the option to get random numbers and does not seed, initialize or start the RNG. Other options are reserved for future use.

Neither continuous testing nor entropy testing is included in this service. If this is needed (FIPS 140, ZKA, ...), this service should not be used and the users shall develop their own command.

The DRNG is compatible with both ANSI X9.31 and FIPS 186-2 standards (see the important note below). The DRNG is designed according to:

- The algorithm described in the document ANSI Digital Signatures Using Reversible Public Key Cryptography for the Financial Services Industry (rDSA) X9.31 dated September 9, 1998.
- The Change recommendation for ANSI X9.0 - 1995 (Part 1) and ANSI X9.31 -1998:

The algorithm B.2.1 Algorithm for computing m Values of x is the one applied in the Toolbox 3 X9.31 DRNG. The DRNG is compatible with:

- The DRNG is described in the document NIST Digital Signature Standard (DSS) FIPS Pub 186-2 January 27, 2000 Appendix 3.1
- The FIPS 186-2 Change Notice 1 dated October 5, 2001 modifies this algorithm.



**Important:** To apply the FIPS 186-2 algorithm, the parameters XSeed[0] and XSeed[1] must be set to the same value.

### 43.3.4.13.2 How to Use the Service

#### 43.3.4.13.3 Description

This service has four possible options described in [Table 43-41](#). Two of these options are reserved for future use. This service performs the following operations:

- Generation of a random number from the Hardware RNG
- Generation of a random number from the Deterministic RNG

#### **Generation of a Random Number from the Hardware RNG**

This service, activated with the option PUKCL\_RNG\_GET, makes it possible to get a random number R from the Hardware RNG:

R = HardwareRandomGenerate()

In the Generation of random from the RNG service, the following parameters need to be provided:

- R the generated number area (pointed by{nu1RBase,u2RLength})

#### 43.3.4.13.4 Generation of a Random Number from the Deterministic RNG

This service, activated with the option PUKCL\_RNG\_X931\_GET, makes it possible to get a random number R from the Deterministic Random Number Generator with input parameters the Key XKey and the Seed XSeed:

(XKey, R) = DeterministicRandomGenerateFromSeed ( XKey, XSeed, Q)



# SAM D5x/E5x Family Data Sheet

## Public Key Cryptography Controller (PUKCC)

In the generation of a random number from the Deterministic RNG service, the following parameters need to be provided:

- XKey the input and output Key (pointed by {nu1XKeyBase,u2XKeyLength})
- XSeed the input Seed (pointed by {nu1XseedBase,u2XKeyLength})
- Q the prime number (pointed by {nu1QBase, 20bytes})
- R the generated number area (pointed by {nu1RBase, 20bytes})

### 43.3.4.13.5 Hardware RNG Parameters Definition

The parameters for the generation of random from the Hardware RNG are described in the following table. This service can easily be accessed through the use of the `PUKCL_Rng()` and `PUKCL()` macros.

**Table 43-39. RNG Service Hardware Generated Parameters**

Parameter	Type	Dir.	Location	Data Length	Before Executing the Service	After Executing the Service
u2Options	u2	I	–	–	Option (see <a href="#">Table 43-41</a> )	Option (see <a href="#">Table 43-41</a> )
nu1RBase	nu1	I	Crypto RAM or Device RAM	u2RLength	Base of R	Base of R filled with random values depending on the option
u2RLength	u2	I	–	–	Length of R	Length of R

### 43.3.4.13.6 Deterministic RNG Parameters Definition

The parameters for the generation of random from the Deterministic RNG are described in the following table. This service can easily be accessed through the use of the `PUKCL_Rng()` and `PUKCL()` macros.

**Table 43-40. RNG Service Deterministic Generated Parameters**

Parameter	Type	Direction	Location	Data Length	Before Executing the Service	After Executing the Service
u2Options	u2	I	–	–	Option (see <a href="#">Table 43-41</a> )	Option (see <a href="#">Table 43-41</a> )
nu1XKeyBase	nu1	I/O	Crypto RAM	u2XKeyLength	Base of XKey	Base of XKey filled with the resulting XKey
nu1Workspace	nu1	NA	Crypto RAM	64 bytes	Base of the workspace	Base of the workspace corrupted
nu1Workspace2 (see <a href="#">Note 1</a> )	nu1	NA	Crypto RAM	2*nu1XKeyLength + 4	Base of the workspace 2	Base of the workspace corrupted
nu1XSeedBase	nu1	I/O	Crypto RAM	max ( 2*u2XKeyLength, 44 bytes)	Base of the values XSeed[0] and XSeed[1]	Base of XSeed filled with the result on 20 bytes

# SAM D5x/E5x Family Data Sheet

## Public Key Cryptography Controller (PUKCC)

.....continued

Parameter	Type	Direction	Location	Data Length	Before Executing the Service	After Executing the Service
u2XKeyLength	u2	I	–	–	Length of XKey, Xseed[0] and Xseed[1]	Length of XKey, Xseed[0] and Xseed[1]
nu1QBase	nu1	I	Crypto RAM	20 bytes	Base of Q	Base of Q
nu1RBase	nu1	I	Crypto RAM	u2RLength	Base of R	Base of R filled with the result on 20 bytes

**Note:**

1. The nu1 Workspace2 must be a multiple of 256.

### 43.3.4.13.7 Options

The option is set by the u2Options input parameter that must take one of the values listed in the following table. Please note that the values, OPTION\_RNG\_SEED and OPTION\_RNG\_GETSEED, are reserved for future use.

**Table 43-41. RNG Service Options**

Option	Purpose	Required Parameters
PUKCL_RNG_SEED	Reserved	Reserved
PUKCL_RNG_GET	Generation of a random number from the RNG	nu1RBase, u2RLength
PUKCL_RNG_X931_GET	Generation of a random number from the Deterministic RNG	nu1XKeyBase, nu1Workspace, nu1XSeedBase, u2XKeyLength, nu1QBase, nu1RBase
PUKCL_RNG_GETSEED	Reserved	Reserved

### 43.3.4.13.8 Code Example

```

PUKCL_PARAM PUKCLParam;
PPUKCL_PARAM pvPUKCLParam = &PUKCLParam;

// ! The Random Number Generator must be initialized and started
// ! following the directives given for the RNG on the chip

PUKCL(u2Option) =...;

// Initializing parameters
PUKCL_Rng(nu1RBase) = <Base of the ram location to store the rng>;
PUKCL_Rng(u2RLength) = <Length of the rng to get>;

// vPUKCL_Process() is a macro command, which populates the service name
// and then calls the library...
vPUKCL_Process(Rng,pvPUKCLParam);
if (PUKCL(u2Status) == PUKCL_OK)
{
    // The RNG generation has been executed correctly
    ...
}

```

# SAM D5x/E5x Family Data Sheet

## Public Key Cryptography Controller (PUKCC)

```
    }  
else // Manage the error
```

### 43.3.4.13.9 Constraints

#### **Random Number Generation**

The following conditions must be avoided to ensure that the service works correctly:

- {nu1RBase,u2RLength} not in RAM
- {nu1RBase,u2RLength} not accessible or authorized for writing

#### **Deterministic Random Number Generation**

The length of the parameter nu1XSeedbase is:  $XSeedLength = \max(2 * u2XKeyLength, 44 \text{ bytes})$  The `max()` macro takes a maximum of two values.

The following conditions must be avoided to ensure that the service works correctly:

- nu1XKeyBase, nu1Workspace, nu1Workspace2, nu1XSeedBase, nu1QBase, nu1RBase are not aligned on 32-bit boundaries
- {nu1XKeyBase, u2XKeyLength}, {nu1Workspace, 64 bytes}, {nu1Workspace2, 2\*u1XKeyLength +4}, {nu1XSeedBase, XSeedLength}, {nu1QBase, 24 bytes} or {nu1RBase, 20 bytes} are not in PUKCC RAM
- u2XKeyLength is either: < 20, > 64 or not a 32-bit length
- nu1Workspace2 not multiple of 256.
- Overlaps exist between two or more of the areas: {nu1XKeyBase, u2XKeyLength}, {nu1Workspace, 64 bytes}, {nu1XSeedBase, XSeedLength}, {nu1QBase, 24 bytes} or {nu1RBase, 20 bytes} The area {nu1RBase, 20} can overlap with {nu1Workspace, 64 bytes} or {nu1QBas, 24 bytes}. The pointer nu1RBase can equal the pointer nu1XSeedBase.

### 43.3.4.13.10 Status Returned Values

**Table 43-42. RNG Service Return Codes**

Returned status	Importance	Meaning
PUKCL_OK	Information	Service functioned correctly

### 43.3.5 Modular Arithmetic Services

This section provides a complete description of the modular arithmetic services, which consists of two sets:

- Modular reductions, which can be used as stand alone operations, or used as a final step of most arithmetic operations (full and small multiplications, squaring).
- Modular operations, which include modular exponentiations (with or without using the CRT) and a probabilistic prime number generation.

These operations work on general data so the modulus has no special form. The modular services are available through:

- a Fast form (may return a congruence of the result, with a high probability to have a Normalized result)
- a Normalized form (returns the exact result, strictly lower than the modulus)
- a Euclidean form (returns the exact result, strictly lower than the modulus)

The following table describes the modes of the modular reduction with the hypothesis:

- In  $GF(p)$ : The modulus is N with length NLength in bytes

# SAM D5x/E5x Family Data Sheet

## Public Key Cryptography Controller (PUKCC)

- In  $GF(2^n)$ : The modulus is  $P[X]$  with length  $NLength$  in bytes

For the exact calculus of  $NLength$  see below.

**Table 43-43. Modular Reduction Modes**

Modular Reduction Form	Input Dynamic	Result Dynamic	Comments
Fast	$GF(p): 0 \leq Input < (N^2) * (2^{32})$ $GF(2^n): Input < ((P[x])^2) * (X^{32})$	$GF(p): 0 \leq Res < N * 4$ $GF(2^n): Res < P[X] * (X^2)$	The fastest reduction available, needs a precomputed constant.
Normalized	$InputLength < NLength + 4$ bytes	$GF(p): 0 \leq Res < N$ $GF(2^n): Res < P[X]$	<p>The correction step does not runs in constant time. Needs a precomputed constant.</p> <p>The Normalize function cannot be applied to the product of two numbers of length <math>u2NLength</math>.</p>
Using Euclidean division	$InputLength < 2 * NLength + 4$ bytes	$GF(p): 0 \leq Res < N$ $GF(2^n): Res < P[X]$	Does not need any precomputed constant.

To be able to use these modular reduction services (except the Euclidean division), first the implementer shall call the setup service, providing the modulus as well as one free memory space for the constant (this constant is used to speed up the modular reduction). In most commands (except the modular exponentiation), the quotient is stored in the high order bytes of the number to be reduced, using only eight bytes more than the maximum size of the number to be reduced.

The following rules must be respected to ensure the modular reduction services function correctly:

- The numbers to be reduced can have any significant length, given the fact it CANNOT BE GREATER than  $2 * u2ModLength + 4$  bytes.
- The modulus SHALL ALWAYS HAVE a significant length of  $<u2ModLength>$  bytes. The modulus must be provided as a  $<u2ModLength + 4>$  bytes long number, padded on the most significant side with a 32-bit word cleared to zero. Not respecting this rule leads to unexpected and wrong results from the modular reduction.
- The normalization operation ALWAYS performs a modular reduction step, and will therefore have the same memory usage as this one.
- The very first operation before any modular operation SHALL BE a modular setup.

### 43.3.5.1 Modular Reduction

#### 43.3.5.1.1 Purpose

This service is used to perform the various steps necessary to perform a modular reduction and accepts as input numbers in  $GF(p)$  or polynomials in  $GF(2^n)$ .

The available options for this service are:

- Work in the  $GF(2^n)$  or in the standard integer arithmetic field  $GF(p)$
- Operation is the generation of the reduction constant.

- Operation is a Modular Reduction.
- Operation is a Normalization.

### 43.3.5.1.2 How to Use the Service

#### 43.3.5.1.3 Description

This service performs one of the following operations:

- Setup of the Fast or Normalize functions: generation of the reduction constant
- Fast Modular Reduction
- Big Modular Reduction (using Euclide's division)
- Normalization

The service name for this operation is `RedMod`.

#### 43.3.5.1.4 Modular Reduction Setup

This service calculates the constant `Cns`, computed from the modulus and used to speed up the modular reduction:

$Cns = SetupConstant(N)$

This service must be processed before the use of the Fast or Normalize functions. In the Setup computations, the following data must be provided:

- `N` the modulus (pointed by  $\{nu1ModBase, u2ModLength + 4\}$ ).
- `Cns` the Setup Constant Result (pointed by  $\{nu1CnsBase, u2ModLength + 12\}$ ).
- `X` used as a workspace (pointed by  $\{nu1XBase, 2 * u2ModLength + 8\}$ ) (include the supplementary bytes; see **Note 2** in [Table 43-44](#))
- `R` used as a workspace (pointed by  $\{nu1RBase, 64 \text{ or } 68\text{bytes}\}$ ).
- `u2ModLength` is the Aligned Significant Length of the modulus and is not the byte Significant Length (see [43.3.3.4 Aligned Significant Length](#)).

#### 43.3.5.1.5 Fast Reductions and Normalization

These commands calculate an approximated or exact Modular Reduction, that is, the result may be greater than the modulus, but is always congruent to the true result.



**Important:** Before using these functions, ensure that the constant `Cns` has been calculated with the setup for the Modular Reduction service.

Input and Result significant values verify:

- For the Fast Modular Reduction:

$$0 \leq X < N^2 \times 2^{32}$$

$$R = X \bmod(N) + k \times N \quad \text{with} \quad 0 \leq k \leq 4$$

- For the Normalize:

$$XLength < (NLength + 4) \text{bytes} \quad R$$

$$= X \bmod(N)$$

In these Fast Modular Reduction and Normalize computations, the following data have to be provided:

- `X` (pointed by  $\{nu1XBase, 2 * u2ModLength + 8\}$ )

# SAM D5x/E5x Family Data Sheet

## Public Key Cryptography Controller (PUKCC)

- The Normalize computation accept as entry a value whose length is lower or equal to  $u2ModLength + 4$  (that is, for example, a value yet reduced but not normalized.). The  $u2ModLength + 4$  MSB bytes are cleared at the beginning of the computation.
- in case of Fast RedMod computations, the value X may verify:  $X < (N^2) * (2^{32})$ .
- include the supplementary bytes; see **Note 3** in [Table 43-45](#))
- R (pointed by {nu1RBase,u2Modlength +4})
- N (pointed by {nu1ModBase,u2ModLength +4})
- Cns (pointed by {nu1CnsBase,u2ModLength +12})
- $u2ModLength$  is the Aligned Significant Length of the modulus and is not the byte Significant Length (see [43.3.3.4 Aligned Significant Length](#)).

The Fast Modular Reduction is able to reduce inputs up to  $<2 * u2ModLength + 4>$  bytes. The input can come from a multiplication of 2  $<u2ModLength + 4>$  bytes numbers. The input X is considered as a  $<2 * u2ModLength + 8>$  bytes number.



**Important:** Additionally the Fast Reduction and Normalize functions need supplemental bytes located on the MSB side of the number to be reduced but these bytes are restored at the end of the operation and are therefore unchanged. However, these bytes are to be taken into account when the mapping is created, and could lead to unexpected results if overlapping with other area used by the function.

The Fast Modular Reduction returns a  $<u2ModLength + 4>$  bytes number, but this number is in fact a  $<u2ModLength + 2>$  significant bytes number. When using the Fast Modular Reduction, the two MSB bytes of the  $<u2ModLength + 2>$  can have a maximum of two lsb bits set (depending on the reduced number and the modulo).

The Normalize computation accepts as entry a resulting value of Fast Modular Reduction and computes an exact result. It can not be applied to the result of the product of two numbers of size NLength: a Fast Modular Reduction must be applied before.

For the Normalize computation, the X value is limited by the preceding formula but the area in memory is bigger as described in [Table 43-45](#).

As input, the Normalize sub-service only accept values, which length is lower or equal to  $u2ModLength + 4$ . The Most Significant  $u2ModLength + 4$  bytes are firstly cleared by this service.

### 43.3.5.1.6 Big Modular Reduction Using Euclide's Division

This command calculates:

$$XLength < (2 \times NLength + 4) \text{ bytes } R \\ = X \bmod(N)$$

In this Big Modular Reduction computations, the following data must be provided:

- X (pointed by {nu1XBase, 2 \*  $u2ModLength + 8$ }) (include the supplementary bytes; see **Note 1** in [Table 43-46](#))
- R (pointed by {nu1RBase,u2Modlength +4})
- N (pointed by {nu1ModBase,u2ModLength +4})
- $u2ModLength$  is the Aligned Significant Length of the modulus and is not the byte Significant Length (see [43.3.3.4 Aligned Significant Length](#))
- Workspace (pointed by {nu1CnsBase,64 or 68}).

# SAM D5x/E5x Family Data Sheet

## Public Key Cryptography Controller (PUKCC)

### 43.3.5.1.7 Modular Reductions Service Parameters Definition

**Table 43-44. RedMod Service Parameters**

Parameter	Type	Direction	Location	Data Length	Before Executing the Service	After Executing the Service
u2Options	u2	I	–	–	Options (see below)	Options (see below)
Specific/CarryIn	Bits	I	–	–	Must be set to zero.	–
Specific/Gf2n	Bit	I	–	–	GF(2 <sup>n</sup> ) Bit	–
Specific/CarryOut Zero Violation	Bits	I	–	–	–	Carry Out, Zero Bit and Violation Bit filled according to the result
nu1ModBase ( see <b>Note 1</b> )	nu1	I	Crypto RAM	u2ModLength + 4	Base of N	Base of N untouched
nu1CnsBase	nu1	I	Crypto RAM	u2ModLength + 12	Base of Cns	Base of Cns filled with the Setup Constant
u2ModLength	u2	I	–	–	Length of N	Length of N
nu1RBase	nu1	I	Crypto RAM	GF(p): 64 bytes GF(2n): 68 bytes	Base of R as a workspace	Base of R workspace corrupted
nu1XBase (see <b>Note 2</b> )	nu1	I	Crypto RAM	2*u2ModLength + 8	Base of X as a workspace	Base of X workspace corrupted

**Note:**

1. The Modulus is to be given as a u2ModLength Aligned Significant Length Bytes however, it has to be provided as a u2ModLength + 4 bytes long number, having the four high-order bytes set to zero.
2. Before the X (pointed by {nu1XBase, 2 \* u2ModLength + 8}) LSB bytes, four supplementary bytes will be saved/restored. Other four supplementary bytes will also be saved/restored after the X MSB bytes. All these supplementary bytes may be entirely in the Crypto RAM (therefore, do not place the X area too near the end of the Crypto RAM) and shall not overlap with other area used by the service.

# SAM D5x/E5x Family Data Sheet

## Public Key Cryptography Controller (PUKCC)

### 43.3.5.1.8 Fast Modular Reductions Service Parameters Definition

**Table 43-45. Fast RedMode and Normalize Service Parameters**

Parameter	Type	Direction	Location	Data Length	Before Executing the Service	After Executing the Service
u2Options	u2	I	–	–	Options (see below)	Options (see below)
Specific/CarryIn	Bits	I	–	–	Must be set to zero.	–
Specific/Gf2n	Bit	I	–	–	GF(2n) Bit	–
Specific/CarryOut Zero Violation	Bits	I	–	–	–	Carry Out, Zero Bit and Violation Bit filled according to the result
nu1ModBase (see <b>Note 1</b> )	nu1	I	Crypto RAM	u2ModLength + 4	Base of N	Base of N untouched
nu1CnsBase	nu1	I	Crypto RAM	u2ModLength + 12	Base of Cns	Base of Cns untouched
u2ModLength	u2	I	–	–	Length of N	Length of N
nu1RBase (see <b>Note 2</b> )	nu1	I	Crypto RAM	u2ModLength + 4	Base of R	Base of R filled with the result
nu1XBase (see <b>Note 3</b> )	nu1	I	Crypto RAM	2*u2ModLength + 8	Base of X the number to reduce	Base of X corrupted

**Note:**

1. The Modulus is to be given as a u2ModLength Aligned Significant Length Bytes however, it has to be provided as a u2ModLength + 4 bytes long number, having the four high-order bytes set to zero.
2. To make profitable the space memory, it is possible to set nu1RBase exactly equal to nu1XBase.
3. After the X (pointed by {nu1XBase, 2 \* u2ModLength + 8}) MSB bytes, supplementary bytes will be saved/restored (8 bytes in case of Fast RedMod, otherwise; 12 bytes). These supplementary bytes may be entirely in the Crypto RAM (therefore, do not place the X area too near the end of the Crypto RAM) and shall not overlap with other area used by the service.

### 43.3.5.1.9 Big Modular Reduction Parameters Definition

**Table 43-46. Big RedMod Service Parameters**

Parameter	Type	Direction	Location	Data Length	Before Executing the Service	After Executing the Service
u2Options	u2	I	–	–	Options (see below)	Options (see below)



# SAM D5x/E5x Family Data Sheet

## Public Key Cryptography Controller (PUKCC)

.....continued

Parameter	Type	Direction	Location	Data Length	Before Executing the Service	After Executing the Service
Specific/CarryIn	Bits	I	–	–	Must be set to zero	–
Specific/Gf2n	Bit	I	–	–	GF(2n) Bit	–
Specific/ CarryOut Zero Violation	Bits	I	–	–	–	Carry Out, Zero Bit and Violation Bit filled according to the result
nu1ModBase	nu1	I	Crypto RAM	u2ModLength + 4	Base of N	Base of N untouched
nu1CnsBase	nu1	I	Crypto RAM	GF(p): 64 bytes GF(2n): 68 bytes	Base of Cns as a workspace	Base of Cns corrupted
u2ModLength	u2	I	–	–	Length of N	Length of N
nu1RBase	nu1	I	Crypto RAM	u2ModLength + 4	Base of R	Base of R filled with the result
nu1XBase (see <b>Note 1</b> )	nu1	I	Crypto RAM	2*u2ModLength + 8	Base of X the number to reduce	Base of X filled with the result

**Note:**

1. Before the X (pointed by {nu1XBase, 2 \* u2ModLength + 8}) LSB bytes, four supplementary bytes will be saved/restored. Other four supplementary bytes will also be saved/restored after the X MSB bytes. All of these supplementary bytes may be entirely in the Crypto RAM (therefore, do not place the X area too near the end of the Crypto RAM) and shall not overlap with other area used by the service.

### 43.3.5.1.10 Options

The options are set by the u2Options input parameter, which is composed of:

- the mandatory Operation Option described in [Table 43-47](#)
- if the Operation Option is PUKCL\_REDMOD\_REDUCTION, the Modular Reduction Sub-Option described in [Table 43-48](#)

The u2Options number is calculated by an Inclusive OR of the options. Some Examples in C language are:

- Operation: Setup for the ModularReductions.  
`PUKCL(u2Options) = PUKCL_REDMOD_SETUP;`
- Operation: Fast ModularReduction.  
`PUKCL(u2Options) = PUKCL_REDMOD_REDUCTION | PUKCL_REDMOD_USING_FASTRED;`

# SAM D5x/E5x Family Data Sheet

## Public Key Cryptography Controller (PUKCC)

For this command three exclusive options can be specified. The following table lists the operations that can be performed.

**Table 43-47. RedMod Service Options**

Option	Purpose	Required Parameters
PUKCL_REDMOD_SETUP	Perform the Cns value computation	nu1ModBase, u2ModLength, nu1CnsBase, nu1XBase
PUKCL_REDMOD_REDUCTION	Perform $R \equiv X \text{ Mod } N$ , see sub-option for details	nu1ModBase, u2ModLength, nu1CndBase, nu1XBase, nu1RBase
PUKCL_REDMOD_NORMALIZE	Perform $R = X \text{ Mod } N$	nu1ModBase, u2ModLength, nu1CndBase, nu1XBase, nu1RBase

When selecting the PUKCL\_REDMOD\_REDUCTION option, one of the two sub-options listed in the following table must be selected.

**Table 43-48. RedMode Service Options with PUKCL\_RED\_MOD\_REDUCTION**

Option	Purpose	Required Parameters
PUKCL_REDMOD_USING_DIVISION	Perform $R = X \text{ Mod } N$	nu1ModBase, u2ModLength, nu1CndBase, nu1XBase
PUKCL_REDMOD_USING_FASTRED	Perform $R \equiv X \text{ Mod } N$ The entropy is minimized (~2 bits)	nu1ModBase, u2ModLength, nu1CndBase, nu1XBase, nu1RBase

### 43.3.5.1.11 Code Example

```

PUKCL_PARAM PUKCLParam;
PPUKCL_PARAM pvPUKCLParam = &PUKCLParam;

PUKCL(Specific).CarryIn = 0;
PUKCL(Specific).GF2n = ...;

PUKCL(u2Option) = ...;

// Depending on the option specified, not all fields should be filled
PUKCL_RedMod(nu1ModBase) = <Base of the ram location of N>;
PUKCL_RedMod(u2ModLength) = <Length of N>;
PUKCL_RedMod(nu1CnsBase) = <Base of the ram location of Cns>;
...

// vPUKCL_Process() is a macro command, which populates the service name
// and then calls the library...
vPUKCL_Process(RedMod,pvPUKCLParam);
if (PUKCL_Param.Status == PUKCL_OK)
{
    // operation has correctly been performed
    ...
}
else // Manage the error

```

### 43.3.5.1.12 Constraints

Depending on the options chosen the lengths of the R area and Cns area differ:

- For the Setup:
  - RLength = 64bytes

# SAM D5x/E5x Family Data Sheet

## Public Key Cryptography Controller (PUKCC)

- CnsLength = u2ModLength +12
- For the Fast Reduction and Normalize:
  - RLength = u2ModLength +4
  - CnsLength = u2ModLength +8
- For the BigRedMod:
  - RLength = u2ModLength +4
  - CnsLength =64

The following combinations of input values should be avoided in the case of a modular reduction ‘alone’, meaning that it has not been requested as an option of any other command:

- nu1ModBase, nu1CnsBase, nu1RBase, nu1XBase are not aligned on 32-bit boundaries
- {nu1ModBase, u2ModLength + 4}, {nu1CnsBase, u2CnsLength}, {nu1XBase, 2\*u2XLength + 8 + s} or {nu1RBase, u2RLength} are not in Crypto RAM
- u2ModLength is either: < 4, > 0xffc or not a 32-bit length
- Overlaps exist between two or more of the areas: {nu1ModBase, u2ModLength + 4},{nu1CnsBase, u2CnsLength}, {nu1XBase, 2\*u2XLength + 8 + s} or {nu1RBase, u2RLength}

**Note:** Overlaps between {nu1RBase, RLength} and {nu1XBase, 2\*u2XLength + 8} are forbidden; but if the operation is the Fast, Normalized or Big Modular Reduction, the equality between nu1RBase and nu1XBase is authorized.

### 43.3.5.1.13 Status Returned Values

**Table 43-49. RedMod Service Return Codes**

Returned Status	Importance	Meaning
PUKCL_OK	–	Service functioned correctly
PUKCL_DIVISION_BY_ZERO	Severe	When computing an Euclidean division, the Modulus was found to be zero. This occurs ONLY when either reducing using an Euclidean division or computing the reduction constant usable for a Fast or Normalize Reduction.
PUKCL_UNEXPLOITABLE_OPTIONS	Severe	A bad combination of options has been detected.
PUKCL_MALFORMED_MODULUS	Severe	The Msw of the modulus is not zero.

### 43.3.5.2 Modular Exponentiation (Without CRT)

#### 43.3.5.2.1 Purpose

This service is used to perform the Modular Exponentiation computation. This service processes integers in GF(p) only.

The options available for this service are:

- Fast implementation
- Regular implementation
- Exponent is located in Crypto RAM or not in Crypto RAM
- Exponent window size

# SAM D5x/E5x Family Data Sheet

## Public Key Cryptography Controller (PUKCC)

### 43.3.5.2.2 How to Use the Service

#### 43.3.5.2.3 Description



**Important:** Before using these functions, ensure that the constant Cns has been calculated with the Setup of the Modular Reductions service.

This service processes the following operation:

The service name for this operation is `ExpMod`.

$$R = X^{Exp} \text{mod}(N)$$

In this computation, the following parameters need to be provided:

- X: input number (pointed by {nu1XBase,u2ModLength +16})
- N: modulus (pointed by {nu1ModBase,u2ModLength +4}).
- Exp: exponent (pointed by {pfu1ExpBase,u2ExpLength +4})
- Cns: Fast Modular Constant (pointed by {nu1CnsBase,u2ModLength +8})
- Precomp: precomputation workspace (pointed by {nu1PrecompBase,PrecompLen})
- Blinding: exponent blinding value (provided in u1Blinding)

The length PrecompLen depends on the lengths and options chosen; its calculus is detailed in Options below.

**Note:** The minimum value for u2ModLength is 12 bytes. Therefore, the significant length of N must be at least three 32-bit words.

#### 43.3.5.2.4 Parameters Definition

**Table 43-50. ExpMod Service Parameters**

Parameter	Type	Direction	Location	Data Length	Before Executing the Service	After Executing the Service
u2Options	u2	I	–	–	Options (see below)	Options (see below)
nu1ModBase	nu1	I	Crypto RAM	u2ModLength + 4	Base of N	Base of N untouched
nu1CnsBase	nu1	I	Crypto RAM	u2ModLength + 8	Base of Cns	Base of Cns untouched
u2ModLength	u2	I	–	–	Length of N	Length of N
nu1XBase (see <b>Note 1</b> )	nu1	I	Crypto RAM	u2ModLength + 16	Base of X	Base of X Filled with the result
nu1PrecompBase	nu1	I	Crypto RAM	See below	Base of Precomp as a workspace	Base of Precomp workspace corrupted

# SAM D5x/E5x Family Data Sheet

## Public Key Cryptography Controller (PUKCC)

.....continued

Parameter	Type	Direction	Location	Data Length	Before Executing the Service	After Executing the Service
pfu1ExpBase (see <b>Note 2</b> )	pfu1	I	Any place (see <b>Note 3</b> )	u2ExpLength + 4	Base of the Exponent	Base of the Exponent untouched
u2ExpLength (see <b>Note 4</b> )	u2	I	–	–	Significant length of Exponent	Significant length of Exponent
u1Blinding (see <b>Note 5</b> )	u1	I	–	–	Exponent unblinding value	Exponent unblinding value untouched

**Note:**

1. This zone contains the number to be exponentiated (u2ModLength bytes) and is used during the computations as a workspace (four 32-bit words longer than the number to be exponentiated). At the end of the computation, it contains the correct result of the operation.
2. The exponent must be given with a supplemental word on the LSB side (low addresses). This word shall be set to zero.
3. If the PUKCL\_EXPMOD\_EXPINPUKCCRAM option is not set, the location of the exponent MUST NOT be the Crypto RAM, even partially.
4. The u2ExpLength parameter does not take into account the supplemental word needed on the LSB side of the exponent.
5. It is possible to mask the exponent in memory using an 8-bits XOR mask value. Be aware that not only the exponent, but also the supplemental word has to be masked. If masking is not desired, then this parameter should be set to 0.

### 43.3.5.2.5 Options

The options are set by the u2Options input parameter, which is composed of:

- the mandatory Calculus Mode Option described in [Table 43-51](#)
- the mandatory Window Size Option described in [Table 43-52](#)
- the indication of the presence of the exponent in Crypto RAM

**Note:** Please check precisely if one part of the exponent is in Crypto RAM. If this is the case the PUKCL\_EXPMOD\_EXPINPUKCCRAM must be used.

The u2Options number is calculated by an “Inclusive OR” of the options. Some examples in C language are:

- Operation:Fast Modular Exponentiation with the window size equal to 1 and with no part of the Exponent in the Crypto RAM  
`PUKCL(u2Options) = PUKCL_EXPMOD_FASTRSA | PUKCL_EXPMOD_WINDOWSIZE_1;`
- Operation: Regular Modular Exponentiation with the window size equal to 2 and with one part of the Exponent in the Crypto RAM  
`PUKCL(u2Options) = PUKCL_EXPMOD_REGULARRSA | PUKCL_EXPMOD_WINDOWSIZE_2 | PUKCL_EXPMOD_EXPINPUKCCRAM;`

# SAM D5x/E5x Family Data Sheet

## Public Key Cryptography Controller (PUKCC)

There is no difference on the final result when using any of the options for this service. The choice has to be made according to the available resources (RAM, Time) and also taking into account the expected security level.

For this service, two exclusive Calculus Modes are possible. The following table describes the Calculus Mode Options.

**Table 43-51. ExpMod Service Calculus Mode Option**

Option	Explanation
PUKCL_EXPMOD_FASTRSA	Performs a Fast computation
PUKCL_EXPMOD_REGULARRSA	Performs a Regular computation, slower than the Fast version, but using Regular calculus methods

For this service, four window sizes are possible. The window size in bits is those of the windowing method used for the exponent.

The choice of the window size is a balance between the size of the parameters and the computation time:

- Increasing the window size increases the precomputation workspace.
- Increasing the window size reduces the computation time (may not be relevant for very small exponents).

The following table details the size of the precomputation workspace, depending on the chosen window size option.

**Table 43-52. ExpMod Service Window Size Options and Precomputation Space Size**

Option specified	Size of the PrecompBase Workspace (bytes)	Content of the Workspace
PUKCL_EXPMOD_WINDOWSIZE_1	$3 \cdot (u2ModLength + 4) + 8$	$x$
PUKCL_EXPMOD_WINDOWSIZE_2	$4 \cdot (u2ModLength + 4) + 8$	$x \ x^3$
PUKCL_EXPMOD_WINDOWSIZE_3	$6 \cdot (u2ModLength + 4) + 8$	$x \ x^3 \ x^5 \ x^7$
PUKCL_EXPMOD_WINDOWSIZE_4	$10 \cdot (u2ModLength + 4) + 8$	$x \ x^3 \ x^5 \ x^7 \ x^9 \ x^{11} \ x^{13} \ x^{15}$

The exponent can be located in RAM or in the data space. If one part of the exponent is in Crypto RAM this must be mandatory signaled by using the option PUKCL\_EXPMOD\_EXPINPUKCCRAM.

The following table describes this option.

**Table 43-53. ExpMod Service Exponent in Crypto RAM Option**

Option	Purpose
PUKCL_EXPMOD_EXPINPUKCCRAM	The exponent can be read from any data space of memory, including Flash, RAM or even Crypto RAM. When at least one word the exponent is in Crypto RAM, this option has to be set.

### 43.3.5.2.6 Code Example

```

PUKCL_PARAM PUKCLParam;
PPUKCL_PARAM pvPUKCLParam = &PUKCLParam;

PUKCL(u2Option) = ...;

```

# SAM D5x/E5x Family Data Sheet

## Public Key Cryptography Controller (PUKCC)

```

// Depending on the option specified, not all fields should be filled
PUKCL_ExpMod(nu1ModBase) = <Base of the ram location of N>;
PUKCL_ExpMod(u2ModLength) = <Length of N>;
PUKCL_ExpMod(nu1CnsBase) = <Base of the ram location of Cns>;
PUKCL_ExpMod(nu1XBase) = <Base of the ram location of X>;
PUKCL_ExpMod(nu1PrecompBase) = <Base of the ram location of Precomp>;
PUKCL_ExpMod(pf1ExpBase) = <Base of the location of Exp>;
PUKCL_ExpMod(u2ExpLength) = <Length of Exp>;
...

// vPUKCL_Process() is a macro command, which populates the service name
// and then calls the library...
vPUKCL_Process(ExpMod, pvPUKCLParam);
if (PUKCL_Param.Status == PUKCL_OK)
    {
        // operation has been performed correctly
        ...
    }
else // Manage the error

```

### 43.3.5.2.7 Constraints

The following combinations of input values should be avoided in the case of a modular reduction ‘alone’, meaning that it has not been requested as an option of any other command:

- nu1ModBase, nu1CnsBase, nu1XBase, nu1PrecompBase, nu1ExpBase are not aligned on 32-bit boundaries
- {nu1ModBase, u2ModLength + 4}, {nu1CnsBase, u2ModLength + 8}, {nu1XBase, u2ModLength + 16}, {nu1PrecompBase, <PrecompLength>} are not in Crypto RAM
- {nu1ExpBase, u2ExpLength + 4} has no part in Crypto RAM and PUKCL\_EXPMOD\_EXPINPUKCCRAM is specified
- u2ModLength or u2ExpLength are either: < 4, > 0xffc or not a 32-bit length
- None or both PUKCL\_EXPMOD\_REGULARRSA and PUKCL\_EXPMOD\_FASTRSA are specified.
- {nu1PrecompBase, <PrecompLength>} overlaps with either: {nu1ModBase, u2ModLength + 4}, {nu1CnsBase, u2ModLength + 8} {nu1XBase, u2ModLength + 16} or {nu1ExpBase, u2ExpLength + 4}
- {nu1XBase, u2ModLength + 16} overlaps with either: {nu1ModBase, u2ModLength + 4}, {nu1CnsBase, u2ModLength + 8} or {nu1ExpBase, u2ExpLength + 4}
- {nu1ModBase, u2ModLength + 4} overlaps {nu1CnsBase, u2ModLength + 8}

### 43.3.5.2.8 Maximum Sizes for the Modular Exponentiation

The following table provides the maximum sizes for the Modular Exponentiation, depending on the window size and the presence of the exponent in Crypto RAM.

- The figures below are calculated supposing that u2ExpLength = u2ModLength.
- In case of the PUKCL\_EXPMOD\_EXPINPUKCCRAM option is specified, for the computation of the maximum acceptable size, it is assumed the Exponent is entirely in the Crypto RAM and its length is equal to the Modulus one.
- Otherwise, the Exponent is entirely out of the Crypto RAM and so the computation do not depend on its length.

**Table 43-54. Maximum Exponentiation Sizes**

Option Specified	Maximum Modulus Size (bytes)	Maximum Modulus Size (bits)
Exponent in Crypto RAM, 1 bit window	576	4608

# SAM D5x/E5x Family Data Sheet

## Public Key Cryptography Controller (PUKCC)

.....continued		
Option Specified	Maximum Modulus Size (bytes)	Maximum Modulus Size (bits)
Exponent in Crypto RAM, 2 bits window	504	4032
Exponent in Crypto RAM, 3 bits window	400	3200
Exponent in Crypto RAM, 4 bits window	284	2272
Exponent not in Crypto RAM, 1 bit window	672	5376
Exponent not in Crypto RAM, 2 bits window	576	4608
Exponent not in Crypto RAM, 3 bits window	448	3584
Exponent not in Crypto RAM, 4 bits window	308	2464

### 43.3.5.2.9 Status Returned Values

**Table 43-55. ExpMod Service Return Codes**

Returned Status	Importance	Meaning
PUKCL_OK	–	Service functioned correctly

### 43.3.5.3 Probable Prime Generation (Using Rabin-Miller)

#### 43.3.5.3.1 Purpose

This service is used to perform probable prime generation or test. This service processes integers in GF(p) only.

The options available for this service are:

- Choice of the number of iterations of the Rabin-Miller test
- Generation or Test of a probable prime number
- Fast Implementation
- Regular Implementation
- Exponent Window Size

#### 43.3.5.3.2 Additional Information

The Rabin-Miller test is a probable-primality testing algorithm. As a consequence, the primality of the generated number is not guaranteed at 100%, however, numerous publications have been issued explaining how to estimate the probability of getting a composite number, giving the size of the number and the number of iterations (the T parameter).

Useful information can be found in the *“Handbook of Applied Cryptography (Discrete Mathematics and Its Applications”* by Alfred J. Menezes, Paul C. van Oorschot, and Scott A. Vanstone, in the following sections:

- 4.2.3. “Rabin-Miller Test”
- 4.4. “Prime Number Generation”

#### 43.3.5.3.3 How to Use the Service

#### 43.3.5.3.4 Description

This service processes a test for probable primality or a generation of a probable prime number.



# SAM D5x/E5x Family Data Sheet

## Public Key Cryptography Controller (PUKCC)

**Note:** When using this service be sure to follow the directives given for the RNG on the chip you use (particularly initialization, seeding) and compulsorily start the RNG.

This service processes one of the following operations: CheckProbablePrimality(N)

or

N = GenerateProbablePrimeFromSeed (NSeed)

In this computation, the following parameters need to be provided:

- N the input number (pointed by {nu1NBase,u2NLength +4})
  - If the requested operation is a test, it is untouched after the operation.
  - If the requested operation is a generation and a probable prime number was found before reaching the Maximum Increment, it contains the resulting probable prime after the operation.
  - If the requested operation was a generation and Maximum Increment was reached before a probable prime number was found, it contains no relevant information.
- Cns as a workspace (pointed by {nu1CnsBase,u2NLength +12})
- Rnd as a workspace (pointed by {nu1RndBase,u2NLength +16})
- Precomp the precomputation workspace (pointed by{nu1PrecompBase,PrecompLen})
- Exp as a workspace (pointed by {pfu1ExpBase,u2ExpLength +4})
- u1MillerRabinIterations the number of Miller Rabin Iterations requested
- u2MaxIncrement, maximum increment of the number in case of probable prime generation

The length PrecompLen depends on the lengths and options chosen; its calculus is detailed in Options below.

The service name for this operation is `PrimeGen`.

### 43.3.5.3.5 Parameters Definition

**Table 43-56. PrimeGen Service Parameters**

Parameter	Type	Direction	Location	Data Length	Before Executing the Service	After Executing the Service
nu1NBase (see <b>Note 1</b> )	nu1	I	Crypto RAM	u2NLength + 4	Base of N Number to test or Seed for the generation	Base of N unchanged if test or generation result ( see <b>Note 1</b> )
nu1CnsBase	nu1	I	Crypto RAM	u2NLength + 12	Base of Cns as a workspace	Base of Cns workspace corrupted
u2NLength	u2	I	–	–	Length of N	Length of N
nu1RndBase	nu1	I	Crypto RAM	Max (u2NLength + 16,64)	Internal Workspace	Internal Workspace corrupted
nu1PrecompBase	nu1	I	Crypto RAM	See Options below	Base of Precomp workspace	Base of Precomp workspace corrupted
nu1RBase (see <b>Note 2</b> )	nu1	–	Crypto RAM	–	–	–
nu1ExpBase (see <b>Note 3</b> )	nu1	I	Crypto RAM	u2NLength + 4	Base of Exponent (R)	Base of Exponent (R)
u1MillerRabin-Iterations	u1	I	–	–	Miller Rabin's T parameter	Miller Rabin's T parameter

# SAM D5x/E5x Family Data Sheet

## Public Key Cryptography Controller (PUKCC)

.....continued

Parameter	Type	Direction	Location	Data Length	Before Executing the Service	After Executing the Service
u2MaxIncrement	u2	I	–	–	Maximum Increment (see <b>Note 4</b> )	Maximum Increment

**Note:**

1. This zone contains the number to be either tested or used as a seed for generation. It has to be provided with one zero word on the MSB side. This area has supplementary constraints (see the following Important note).
1. This parameter does not have to be provided and is used as an internal value for computing the reduction's constant.
2. The area {nu1ExpBase, u2NLength + 4} must be entirely in the Crypto RAM.
3. The generation starts from the number in {nu1NBase, u2NLength + 4} and increments it until a number is found as probable prime. However, the generation may stop for two reasons: The number has been incremented in a way it is bigger than <u2NLength> bytes, or the original number has been incremented by more than <u2MaxIncrement>.

In case of probable prime generation, ensure that the addition of NSeed and Maximum Increment is not a number with more bytes than u2NLength, as this would produce an overflow.



**Important:**

One additional word is used on the LSB side of the NBase parameter; this word is restored at the end of the calculus. As a consequence, the parameter nu1NBase must never be at the beginning of the Crypto RAM, but at least at one word from the beginning.

One additional word is used on the MSB side of the NBase parameter; this word is not corrupted. As a consequence the Area {nu1NBase, u2NLength} must not be at the end of the Crypto RAM but at least at one word from the end.

Prime numbers of a size lower than 96 bits (three 32-bit words) cannot be generated or tested by this service.

**43.3.5.3.6 Options**

Some of the Prime Generation options configure the Modular Exponentiation steps and so are very similar to the Modular Exponentiation options.

The options are set by the u2Options input parameter, which is composed of:

- the mandatory Operation Option described in [Table 43-57](#)
- the mandatory Calculus Mode Option described in [Table 43-58](#)
- the mandatory Window Size Option described in [Table 43-59](#)

The u2Options number is calculated by an “Inclusive OR” of the options. Some Examples in C language are:

- Operation: Probable Prime Testing with Fast Modular Exponentiation and the window size equal to 1  
`PUKCL(u2Options) = PUKCL_PRIMEGEN_TEST | PUKCL_EXPMOD_FASTRSA | PUKCL_EXPMOD_WINDOWSIZE_1;`
- Operation: Probable Prime Generate with Regular Modular Exponentiation and the window size equal to 2

# SAM D5x/E5x Family Data Sheet

## Public Key Cryptography Controller (PUKCC)

PUKCL(u2Options) = PUKCL\_EXPMOD\_REGULARRSA | PUKCL\_EXPMOD\_WINDOWSIZE\_2;

The following table describes the PrimeGen service features available from the various options.

**Table 43-57. PrimeGen Service Options**

Option	Method Used
PUKCL_PRIMEGEN_TEST	This option is used to specify that only tests will be made on the provided number.  When this option is not specified, a prime generation algorithm is selected, starting from the given seed and incrementing it.
PUKCL_EXPMOD_WINDOWSIZE_1,2,3 or 4	Depending on this option, different bit-window sizes will be used. For long exponents, the bigger the window, the faster the computation. However, this has also an impact on the size of the precomputations table.

For this service, two exclusive Calculus Modes are possible. The following table describes the Calculus Mode Options.

**Table 43-58. PrimeGen Service Calculus Mode Options**

Option	Explanation
PUKCL_EXPMOD_FASTRSA	Perform a Fast computation.
PUKCL_EXPMOD_REGULARRSA	Performs a Regular computation, slower than the Fast version, but using regular calculus methods.

The length of the Precomp area depends on the window size W and u2NLength. The Precomp area length is:

$$\text{PrecompLen} = \max(2 \cdot (\text{u2NLength} + 4) + 2W - 1 \cdot (\text{u2NLength} + 4), \text{u2NLength} + 8 + 64) + 8$$

**Note:** Please calculate precisely the length PrecompLen with the formula and the `max()` macro, which takes a maximum of two values.

The following table shows the size of the precomputation workspace (PrecompLen), depending on the chosen window size option.

**Table 43-59. PrimeGen Service Precomputation Space Size**

Option Specified	Size of the PrecompBase Workspace (bytes)	Content of the Workspace
PUKCL_EXPMOD_WINDOWSIZE_1	$\max(3 \cdot (\text{u2NLength} + 4), \text{u2NLength} + 72) + 8$	x
PUKCL_EXPMOD_WINDOWSIZE_2	$\max(4 \cdot (\text{u2NLength} + 4), \text{u2NLength} + 72) + 8$	x x <sup>3</sup>
PUKCL_EXPMOD_WINDOWSIZE_3	$\max(6 \cdot (\text{u2NLength} + 4), \text{u2NLength} + 72) + 8$	x x <sup>3</sup> x <sup>5</sup> x <sup>7</sup>

# SAM D5x/E5x Family Data Sheet

## Public Key Cryptography Controller (PUKCC)

.....continued

Option Specified	Size of the PrecompBase Workspace (bytes)	Content of the Workspace
PUKCL_EXPMOD_WINDOWSIZE_4	$\max(10 \cdot (u2NLength + 4) \cdot u2NLength + 72) + 8$	$x \ x^3 \ x^5 \ x^7 \ x^9 \ x^{11} \ x^{13} \ x^{15}$

The following table provides the maximum sizes for the Prime Generation depending on the window size.

**Table 43-60. PrimeGen Service Maximum Sizes**

Characteristics of the Operation	Maximum Prime Sizes (bits)
1 bit window	4608
2 bits window	4032
3 bits window	3200
4 bits window	2272

### 43.3.5.3.7 Code Example

```

PUKCL_PARAM PUKCLParam;
PPUKCL_PARAM pvPUKCLParam = &PUKCLParam;

// ! The Random Number Generator must be initialized and started
// ! following the directives given for the RNG on the chip PUKCL(u2Option) =...;
// Depending on the option specified, not all fields should be filled
PUKCL_PrimeGen(nu1NBase) = <Base of the ram location of N>;
PUKCL_PrimeGen(u2NLength) = <Length of N>;
PUKCL_PrimeGen(nu1CnsBase) = <Base of the ram location of Cns>;
PUKCL_PrimeGen(nu1PrecompBase) = <Base of the ram location of Precomp>;
PUKCL_PrimeGen(pf1ExpBase) = <Base of the location of Exp>;
PUKCL_PrimeGen(u2ExpLength) = <Length of Exp>;
PUKCL_PrimeGen(u1MillerRabinIterations) = <Number of iterations>;
PUKCL_PrimeGen(u2MaxIncrement) = <Maximum Increment>;
...

// vPUKCL_Process() is a macro command, which populates the service name
// and then calls the library...
vPUKCL_Process(PrimeGen, pvPUKCLParam);
if (PUKCL_Param.Status == PUKCL_NUMBER_IS_PRIME)
{
    // The number is probably prime
    ...
}
else if (PUKCL_Param.Status == PUKCL_NUMBER_IS_NOT_PRIME)
{
    // The number is not prime
    ...
}
else // Manage the error

```

### 43.3.5.3.8 Constraints

The following combinations of input values should be avoided in the case of a modular reduction 'alone', meaning that it has not been requested as an option of any other service:

- nu1NBase, nu1CnsBase, nu1RndBase, nu1PrecompBase, nu1ExpBase are not aligned on 32-bit boundaries
- {nu1NBase, u2NLength + 4}, {nu1CnsBase, u2NLength + 12}, {nu1RndBase, u2NLength + 12}, {nu1PrecompBase, <PrecompLength>} are not in Crypto RAM
- u2NLength is either: < 12, > 0xffc or not a 32-bit length
- Both PUKCL\_EXPMOD\_REGULARRSA and PUKCL\_EXPMOD\_FASTRSA are specified.

# SAM D5x/E5x Family Data Sheet

## Public Key Cryptography Controller (PUKCC)

- $\{\text{nu1PrecompBase}, \langle \text{PrecompLength} \rangle\}$  overlaps with either:  $\{\text{nu1NBase}, \text{u2NLength} + 4\}$ ,  $\{\text{nu1CnsBase}, \text{u2NLength} + 12\}$   $\{\text{nu1RndBase}, \text{u2NLength} + 12\}$  or  $\{\text{nu1ExpBase}, \text{u2ExpLength} + 4\}$
- $\{\text{nu1RndBase}, 3 * \text{u2NLength} + 24\}$  overlaps with either:  $\{\text{nu1NBase}, \text{u2NLength} + 4\}$ ,  $\{\text{nu1CnsBase}, \text{u2NLength} + 12\}$   $\{\text{nu1XBase}, \text{u2NLength} + 12\}$  or  $\{\text{nu1ExpBase}, \text{u2ExpLength} + 4\}$
- $\{\text{nu1NBase}, \text{u2NLength} + 4\}$  overlaps  $\{\text{nu1CnsBase}, \text{u2NLength} + 12\}$

### 43.3.5.3.9 Status Returned Values

**Table 43-61. PrimeGen Service Return Codes**

Returned Status	Importance	Meaning
PUKCL_NUMBER_IS_PRIME	Information	The generated or tested number has been detected as probably prime.
PUKCL_NUMBER_IS_NOT_PRIME	Information	The generated or tested number has been detected as composite.

### 43.3.5.4 Modular Exponentiation (With CRT)

#### 43.3.5.4.1 Purpose

The purpose of this service is to perform the Modular Exponentiation with the Chinese Remainders Theorem (CRT). This service processes integers in GF(p) only.

The options available for this service are:

- Fast implementation
- Regular implementation
- Exponent is located in Crypto RAM or not
- Exponent window size

#### 43.3.5.4.2 How to Use the Service

#### 43.3.5.4.3 Description

This service processes a Modular Exponentiation with the Chinese Remainder Theorem:

$$R = X^D \text{mod}(N) \text{ with } N = P * Q$$



**Important:** For this service, be sure to follow the directives given for the RSA implementation on the chip you use.

This service requires that the modulus N is the product of two co-primes P and Q and that the decryption exponents D is co-prime with the product  $((P-1)*(Q-1))$ .

The Input data are P, Q, EP, EQ, Rvalue, and X. P and Q are the co-primes so that  $N = P * Q$ .

X is the number to exponentiate.

EP, EQ and Rval are calculated as follows:

$$EP = D \text{mod}(P - 1) \quad EQ = D \text{mod}(Q - 1) \quad Rval = P^{-1} \text{mod}(Q)$$

In some cases, the decryption exponent D may not be available and the encryption exponent E may be available instead. The possibilities to calculate the parameters are:

- Calculate D from E with the formula:  

$$D = E^{-1} \text{mod}((P - 1) * (Q - 1))$$

# SAM D5x/E5x Family Data Sheet

## Public Key Cryptography Controller (PUKCC)

- Calculate the parameters from E:  
 $EP = E^{-1} \bmod (P - 1)$   $EQ = E^{-1} \bmod (Q - 1)$   $Rval = P^{-1} \bmod (Q)$

In this computation, the following parameters need to be provided:

- X the input number (pointed by {nu1XBase, 2\*u2ModLength + 16})
- P and Q the primes (pointed by {nu1ModBase, 2\*u2ModLength + 8}).
- EP and EQ the reduced exponents (pointed by {pfu1ExpBase, 2\*u2ExpLength + 8})
- Rval and Precomp (pointed by {nu1PrecompBase, RAndPrecompLen})
- Blinding the exponent blinding value (provided in u1Blinding)

The length RAndPrecompLen depends on the lengths and options chosen; its calculus is detailed in Options below.

The service for this operation is CRT.

**Note:** The minimum value for u2ModLength is 12 bytes. Therefore, the significant length of P or Q must be at least three 32-bit words.

#### 43.3.5.4.4 Parameters Definition

The following table shows the parameter block for the CRT service.

Many parameters have complex placement in memory; therefore, detailed figures are provided in CRT Service Placement below.

**Table 43-62. CRT Service Parameters**

Parameter	Type	Direction	Location	Data Length	Before Executing the Service	After Executing the Service
u2Options	u2	I	–	–	Options (see below)	Options (see below)
nu1ModBase	nu1	I	Crypto RAM	2*u2ModLength + 8	Base of P, Q	Base of P, Q untouched
u2ModLength	u2	I	–	–	Length of P or Q greater than or equal to 12	Length of P or Q
nu1XBase (see <b>Note 1</b> )	nu1	I	Crypto RAM	2*u2ModLength + 16	Base of X	Base of X Filled with the result
nu1PrecompBase	nu1	I	Crypto RAM	See Options below	Base of Rvalue and Pre computations workspace	Corrupted
pfu1ExpBase (see <b>Note 2</b> )	pfu1	I	Any place	2*u2ExpLength + 8	Base of EP, EQ	Base of EP, EQ untouched
u2ExpLength	u2	I	–	–	Significant length of EP or EQ	Significant length of EP or EQ

# SAM D5x/E5x Family Data Sheet

## Public Key Cryptography Controller (PUKCC)

.....continued

Parameter	Type	Direction	Location	Data Length	Before Executing the Service	After Executing the Service
u1Blinding (see <b>Note 3</b> )	u4	I	–	–	Exponent unblinding value	Exponent unblinding value

**Note:**

1. This zone contains the number to be exponentiated (u2ModLength bytes) and is used during the computations as a workspace (four 32-bit words longer than the number to be exponentiated). At the end of the computation, it contains the correct result of the operation.
2. If the PUKCL\_EXPMOD\_EXPINPUKCCRAM option is not set, the location of the exponent MUST NOT be placed in the Crypto RAM, even partially.
3. It is possible to mask the exponent in memory using a 32-bit XOR mask value. Be aware that not only the exponent, but also the supplemental spill word has to be masked. If masking is not desired, the parameter should be set to 0.

#### 43.3.5.4.5 Options

Most of the CRT options configure the Modular Exponentiation steps of the CRT and so are very similar to the Fast Modular Exponentiation options.

The options are set by the u2Options input parameter, which is composed of:

- the mandatory Calculus Mode Option described in [Table 43-63](#)
- the mandatory Window Size Option described in [Table 43-64](#)
- the indication of the presence of the exponent in Crypto RAM



**Important:** Please check precisely if one part of the exponent area (containing EP and EQ) is in Crypto RAM. If this is the case, the PUKCL\_EXPMOD\_EXPINPUKCCRAM option must be used.

The u2Options number is calculated by an “Inclusive OR” of the options. Some Examples in C language are:

- Operation: CRT using the Fast Modular Exponentiation with the window size equal to 1 and with no part of the Exponent area in the Crypto RAM  
`PUKCL(u2Options) = PUKCL_EXPMOD_FASTRSA | PUKCL_EXPMOD_WINDOWSIZE_1;`
- Operation: CRT using the Regular Modular Exponentiation with the window size equal to 2 and with one part the Exponent area in the Crypto RAM  
`PUKCL(u2Options) = PUKCL_EXPMOD_REGULARRSA | PUKCL_EXPMOD_WINDOWSIZE_2 | PUKCL_EXPMOD_EXPINPUKCCRAM;`

For this service, two exclusive Calculus Modes for the Modular Exponentiation steps of the CRT are possible. The following table describes the Calculus Mode Options.

**Table 43-63. CRT Service Calculus Mode Options**

Option	Explanation
PUKCL_EXPMOD_FASTRSA	Perform a Fast computation.

# SAM D5x/E5x Family Data Sheet

## Public Key Cryptography Controller (PUKCC)

.....continued

Option	Explanation
PUKCL_EXPMOD_REGULARRSA	Performs a Regular computation, slower than the Fast version, but using regular calculus methods.

For this service, four window sizes for the Modular Exponentiation Steps are possible. The window size in bits is those of the windowing method used for the exponent.

The choice of the window size is a balance between the size of the parameters and the computation time:

- Increasing the window size increases the precomputation workspace.
- Increasing the window size reduces the computation time (may not be relevant for very small exponents). The length of the Rval and Precomp area depends on the window size  $W$  and  $u2ModLength$ .

The Rval and Precomp area length is:

$$RandPrecompLen = 4 * (u2ModLength + 4) + \max(64, 2^{(W-1)} * (u2ModLength + 4)) + 8$$



**Important:** Please calculate precisely the length  $RandPrecompLen$  with the formula and the `max()` macro, which takes the maximum of two values.

The following table shows the size of the Rval and Precomp area, depending on the chosen window size option.

**Table 43-64. CRT Service Window Size Options and Rval and Precomp Area Size**

Option Specified	Size of the Rval and Precomp Area (bytes)	Precomputation Values
PUKCL_EXPMOD_WINDOWSIZE_1	$4 * (u2ModLength + 4) + \max(64, (u2ModLength + 4)) + 8$	$x$
PUKCL_EXPMOD_WINDOWSIZE_2	$4 * (u2ModLength + 4) + \max(64, 2 * (u2ModLength + 4)) + 8$	$x x^3$
PUKCL_EXPMOD_WINDOWSIZE_3	$4 * (u2ModLength + 4) + \max(64, 4 * (u2ModLength + 4)) + 8$	$x x^3 x^5 x^7$
PUKCL_EXPMOD_WINDOWSIZE_4	$10 * (u2ModLength + 4) + \max(64, 8 * (u2ModLength + 4)) + 8$	$x x^3 x^5 x^7 x^9 x^{11} x^{13} x^{15}$

The exponent area can be located in RAM or in the data space. If one part of the exponent area is in Crypto RAM this must be mandatory signaled by using the `PUKCL_EXPMOD_EXPINPUKCCRAM` option.

The following table describes this option.



# SAM D5x/E5x Family Data Sheet

## Public Key Cryptography Controller (PUKCC)

**Table 43-65. CRT Service Crypto RAM Option Exponent Area**

Option	Purpose
PUKCL_EXPMOD_EXPINPUKCCRAM	The exponent area can be read from any data space of memory, including Crypto RAM. When at least one word the exponent is in Crypto RAM, this option has to be set.

### 43.3.5.4.6 Code Example

```

PUKCL_PARAM PUKCLParam;
pvPUKCL_PARAM pvPUKCLParam = &PUKCLParam;

PUKCL(u2Option) =...;

// Depending on the option specified, not all fields should be filled
PUKCL_CRT(nu1ModBase) = <Base of the ram location of P and Q>; PUKCL_CRT(u2ModLength) = <Length of P or Q>;
PUKCL_CRT(nu1XBase) = <Base of the ram location of X>;
PUKCL_CRT(nu1PrecompBase) = <Base of the ram location of RVal and Precomp>;
PUKCL_CRT(pf1ExpBase) = <Base of the ram location of EP and EQ>;
PUKCL_CRT(u2ExpLength) = <Length of EP or EQ>;
PUKCL_CRT(u1Blinding) = <Blinding value>;
...

// vPUKCL_Process() is a macro command, which populates the service name
// and then calls the library...
vPUKCL_Process(CRT, pvPUKCLParam);
if (PUKCL_Param.Status == PUKCL_OK)
{
    // operation has been performed correctly
    ...
}
else // Manage the error

```

### 43.3.5.4.7 Constraints

The following conditions must be avoided to ensure that the service works correctly:

- nu1ModBase, nu1XBase, nu1PrecompBase, pf1ExpBase are not aligned on 32-bit boundaries
- {nu1XBase, 2\*u2ModLength + 16}, {nu1ModBase, 2\*u2ModLength + 8}, {nu1PrecompBase, <PrecompLength>} are not in Crypto RAM
- {nu1ExpBase, 2\*u2ExpLength + 8} is not in Crypto RAM and PUKCL\_EXPMOD\_EXPINPUKCCRAM is specified
- u2ModLength or u2ExpLength are either: < 4, > 0xffc or not a 32-bit length
- None or both PUKCL\_EXPMOD\_REGULARRSA and PUKCL\_EXPMOD\_FASTRSA are specified.
- {nu1XBase, 2\*u2ModLength + 16} overlaps with either: {nu1ModBase, 2\*u2ModLength + 8}, {nu1PrecompBase, <PrecompLength>} or {pf1ExpBase, 2\*u2ExpLength + 8}
- {nu1ModBase, 2\*u2ModLength + 8} overlaps with either: {nu1PrecompBase, <PrecompLength>} or {pf1ExpBase, 2\*u2ExpLength + 8}
- {nu1PrecompBase, <PrecompLength>} overlaps {pf1ExpBase, 2\*u2ExpLength + 8}

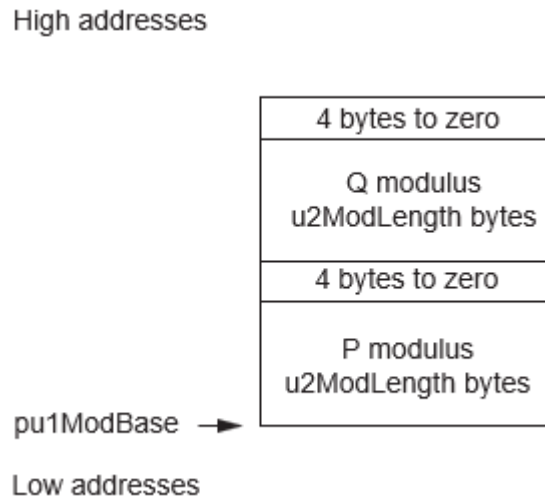
### 43.3.5.4.8 CRT Service Parameter Placement

The parameters' placements are described in detail in the following figures.

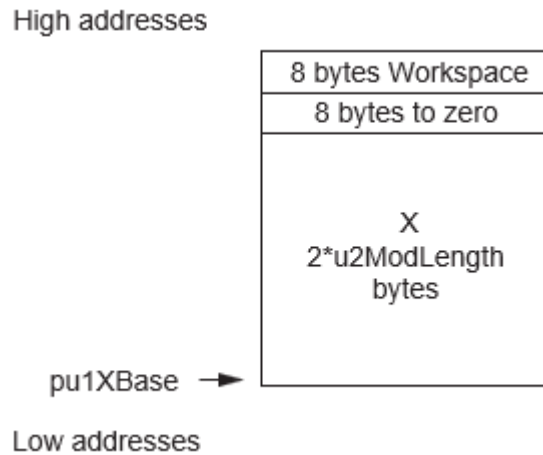
# SAM D5x/E5x Family Data Sheet

## Public Key Cryptography Controller (PUKCC)

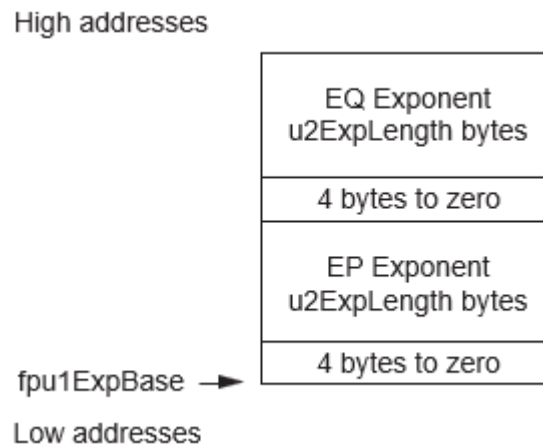
**Figure 43-2. Modulus P and Q in {nu1ModBase, 2\*u2ModLength + 8}**



**Figure 43-3. Value X in {nu1XBase, 2\*u2ModLength + 16}**



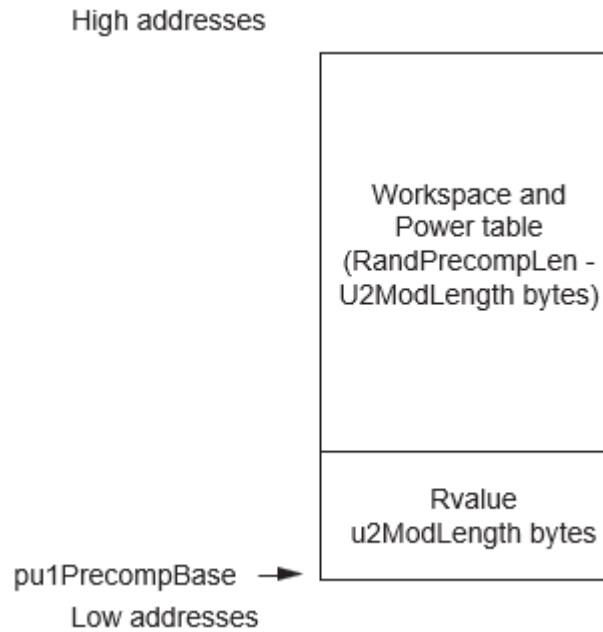
**Figure 43-4. Exponents EP and EQ in {fpu1ExpBase, 2\*u2ExpLength + 8}**



# SAM D5x/E5x Family Data Sheet

## Public Key Cryptography Controller (PUKCC)

**Figure 43-5. Value Rval and Precomp in {nu1PrecompBase, RandPrecompLen}**



#### 43.3.5.4.9 CRT Service Modular Exponentiation Maximum Size

The following table details the maximum size in bits of P or Q, of N and of EP or EQ.

- The maximum size in bits of P or Q equals:  
 $\langle \text{Max Size Bits P} \rangle = \langle \text{Max Size Bits Q} \rangle = 8 * \langle \text{Max u2ModLength bytes} \rangle$
- The maximum size in bits of  $N=P*Q$  equals:  
 $\langle \text{Max Size Bits N} \rangle = 2 * \langle \text{Max Size Bits P} \rangle$
- The maximum size in bits of EP or EQ equals:  
 $\langle \text{Max Size Bits EP} \rangle = \langle \text{Max Size Bits EQ} \rangle = 8 * \langle \text{Max u2ExpLength bytes} \rangle$
- In case of the PUKCL\_EXPMOD\_EXPINPUKCCRAM option is specified, for the computation of the maximum acceptable size, it is assumed the Exponent is entirely in the Crypto RAM and its length equal the Modulus one.
- Otherwise, the Exponent is entirely out of the Crypto RAM and so the computation do not depend on its length.

**Table 43-66. CRT Service Maximum Sizes**

Characteristics of the Operation	P or Q Max Bit Sizes	N Max Bit Sizes	EP or EQ Max Bit Sizes
Exponent in Crypto RAM, 1 bit window	2912	5824	2912
Exponent in Crypto RAM, 2 bits window	2688	5376	2688
Exponent in Crypto RAM, 3 bits window	2464	4928	2464
Exponent in Crypto RAM, 4 bits window	2304	4608	2304
Exponent not in Crypto RAM, 1 bit window	3584	7168	<application dependent>
Exponent not in Crypto RAM, 2 bits window	3232	6464	<application dependent>
Exponent not in Crypto RAM, 3 bits window	2912	5824	<application dependent>

# SAM D5x/E5x Family Data Sheet

## Public Key Cryptography Controller (PUKCC)

.....continued			
Characteristics of the Operation	P or Q Max Bit Sizes	N Max Bit Sizes	EP or EQ Max Bit Sizes
Exponent not in Crypto RAM, 4 bits window	2688	5376	<application dependent>

### 43.3.5.4.10 Status Returned Values

**Table 43-67. CRT Service Return Codes**

Returned Status	Importance	Meaning
PUKCL_OK	Information	Service functioned correctly

### 43.3.6 Elliptic Curves Over GF(p) Services

This section provides a complete description of the currently available elliptic curve over Prime Fields services. These services process integers in GF(p) only.

The offered services cover the basic operations over elliptic curves such as:

- Adding two points over a curve
- Doubling a point over a curve
- Multiplying a point by an integral constant
- Converting a point's projective coordinates (resulting from a doubling or an addition) to the affine coordinates, and oppositely converting a point's affine coordinates to the projective coordinates.
- Testing the point presence on the curve.

Additionally, some higher level services covering the needs for signature generation and verification are offered:

- Generating an ECDSA signature (compliant with FIPS186-2)
- Verifying an ECDSA signature (compliant with FIPS186-2) The supported curves use the following curve equation:

$$Y^2 = X^3 + aX + b$$

#### 43.3.6.1 Coordinate Systems

##### 43.3.6.1.1 General Considerations

In this implementation, several choices have been made related to the coordinate systems managed by the elliptic curve primitives.

There are two systems currently managed by the library:

- Affine Coordinates System where each curve point has two coordinates (X, Y)
- Projective Coordinates System where each point is represented with three coordinates (X,Y, Z)

Converting from the affine coordinates system to a projective coordinates system is performed by extending its representation with Z = 1:

$$(X, Y) \Rightarrow (X, Y, Z= 1)$$

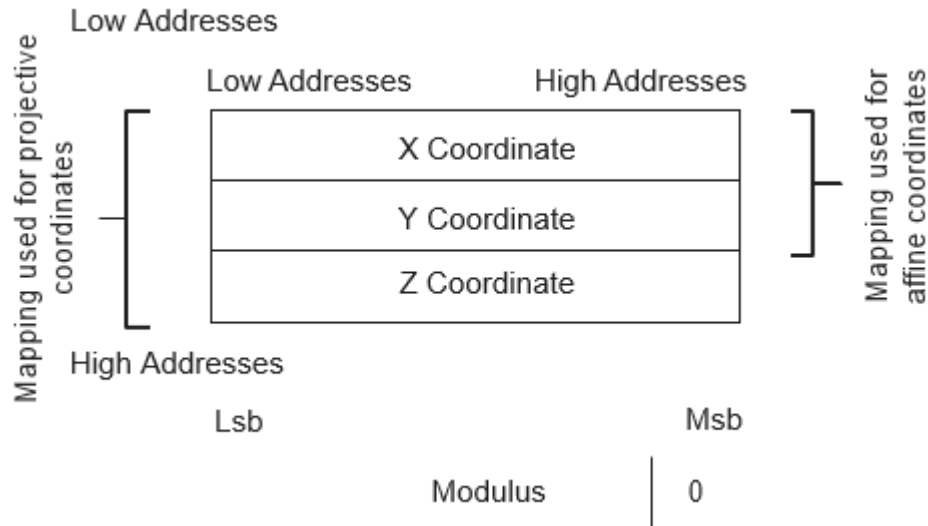
Converting from a projective coordinate to an affine one is a service offered by the PUKCL. The formula to perform this conversion is:

$$(X, Y, Z) \Rightarrow (X / Z^2, Y / Z^3)$$

### 43.3.6.1.2 Points Representations

Depending on the representation (Projective or Affine), points are represented in memory, as shown in the following figure.

**Figure 43-6. Points Representation in Memory**



In this figure, the modulus is represented as a reference, and to show that coordinates are always to be provided on the length of the modulus plus one 32-bit word.

The different types of representations are as follows:

$$\text{Affine representation} \quad Pt = \begin{bmatrix} X_{Affine} < P \times 2^{15} \\ Y_{Affine} < P \times 2^{15} \end{bmatrix}$$

$$\text{Projective representation} \quad Pt = \begin{bmatrix} X_{Projective} < P \times 2^{15} \\ Y_{Projective} < P \times 2^{15} \\ Z_{Projective} < P \times 2^{15} \end{bmatrix}$$

**Note:**

1. The minimum value for u2ModLength is 12 bytes. Therefore, the significant length of the modulus must be at least three 32-bit words.
2. In some cases the point can be the infinite point. In this case, it is represented with its Z coordinates equal or congruent to zero.

### 43.3.6.1.3 Modulus and Modular Constant Parameters

In most of the services the following parameters must be provided:

- P the Modulus (often pointed by {nu1ModBase,u2ModLength + 4}): This parameter contains the Modulus Integer prime P defining the Galois Field used in points coordinates computations. The Modulus must be u2ModLength bytes long, while having a supplemental zeroed 32-bit word on the MSB side.

# SAM D5x/E5x Family Data Sheet

## Public Key Cryptography Controller (PUKCC)

---

**Note:** Most of the Elliptic Curve computations are reduced modulo P. In many functions the reductions are made with the Fast Reduction.

- Cns the Modular Constant (often pointed by {nu1CnsBase,u2ModLength + 12}): This parameter contains the Modular Constant associated to the Modulus



**Important:** The Modular Constant must be calculated before using the GF(p) Elliptic Curves functions by a call to the Setup for Modular Reductions with the GF(p) option (see Modular Reduction Setup in the [43.3.5.1 Modular Reduction](#) section).

---

### 43.3.6.2 Point Addition

#### 43.3.6.2.1 Purpose

This service is used to perform a point addition, based on a given elliptic curve over GF(p). Please note that:

- This service is not intended to add the same point twice. In this particular case, use the doubling service (see [43.3.6.4 Fast Point Doubling](#)).

#### 43.3.6.2.2 How to Use the Service

#### 43.3.6.2.3 Description

The operation performed is:

$$Pt_C = Pt_A + Pt_B$$

In this computation, the following parameters need to be provided:

- A the input point is filled in projective coordinates (X,Y,Z) (pointed by {nu1PointABase, 3\*u2ModLength + 12}). This point can be the Infinite Point.
- B the input point is filled in projective coordinates (X,Y,Z) (pointed by {nu1PointBBase, 3\*u2ModLength + 12}). This point can be the Infinite Point.
- Cns the Fast Modular Constant filled (pointed by {nu1CnsBase,u2ModLength + 8})
- P the modulus filled (pointed by {nu1ModBase,u2ModLength + 4})
- The workspace not initialized (pointed by {nu1WorkSpace, 5\*u2ModLength + 32})

The resulting C point is represented in projective coordinates (X,Y,Z) and is stored at the very same place than the input point A. This Point can be the Infinite Point.

The service name for this operation is `ZpEccAddFast`. This service uses Fast mode and Fast Modular Reduction for computations.



**Important:** Before using this service, ensure that the constant Cns has been calculated with the Setup of the Modular Reduction functions.

---

# SAM D5x/E5x Family Data Sheet

## Public Key Cryptography Controller (PUKCC)

### 43.3.6.2.4 Parameters Definition

**Table 43-68. ZpEccAddFast Service Parameters**

Parameter	Type	Direction	Location	Data Length	Before Executing the Service	After Executing the Service
nu1ModBase	nu1	I	Crypto RAM	u2ModLength + 4	Base of Modulus P	Base of Modulus P
nu1CnsBase	nu1	I	Crypto RAM	u2ModLength + 8	Base of Cns	Base of Cns
u2ModLength	u2	I	–	–	Length of modulo	Length of modulo
nu1PointABase	nu1	I/O	Crypto RAM	3*u2ModLength + 12	Input point A (projective coordinates)	Resulting point C (projective coordinates)
nu1PointBBase	nu1	I	Crypto RAM	3*u2ModLength + 12	Input point B (projective coordinates)	Input point B
nu1Workspace	nu1	I	Crypto RAM	5*u2ModLength + 32	–	Corrupted workspace

### 43.3.6.2.5 Code Example

```

PUKCL_PARAM PUKCLParam;
PPUKCL_PARAM pvPUKCLParam = &PUKCLParam;

PUKCL (u2Option) = 0;

PUKCL _ZpEccAdd(nu1ModBase) = <Base of the ram location of P>;
PUKCL _ZpEccAdd(nu1CnsBase) = <Base of the ram location of Cns>;
PUKCL _ZpEccAdd(u2ModLength) = <Byte length of P>;
PUKCL _ZpEccAdd(nu1PointABase) = <Base of the ram location of the A point>;
PUKCL _ZpEccAdd(nu1PointBBase) = <Base of the ram location of the B point>;
PUKCL _ZpEccAdd(nu1Workspace) = <Base of the ram location of the workspace>;
...

// vPUKCL_Process() is a macro command, which populates the service name
// and then calls the library...
vPUKCL_Process(ZpEccAddFast, &PUKCLParam);
if (PUKCL (u2Status) == PUKCL_OK)
{
    ...
}
else // Manage the error

```

### 43.3.6.2.6 Constraints

No overlapping between either input and output are allowed. The following conditions must be avoided to ensure that the service works correctly:

- nu1ModBase, nu1CnsBase, nu1PointABase, nu1PointBBase, nu1Workspace are not aligned on 32-bit boundaries
- {nu1ModBase, u2ModLength + 4}, {nu1CnsBase, u2ModLength + 8}, {nu1PointABase, 3\*u2ModLength + 12}, {nu1PointBBase, 3\*u2ModLength + 12}, {nu1Workspace, <WorkspaceLength>} are not in Crypto RAM
- u2ModLength is either: < 12, > 0xffc or not a 32-bit length

# SAM D5x/E5x Family Data Sheet

## Public Key Cryptography Controller (PUKCC)

- All overlapping between {nu1ModBase, u2ModLength + 4}, {nu1CnsBase, u2ModLength + 8}, {nu1PointABase, 3\*u2ModLength + 12}, {nu1PointBBase, 3\*u2ModLength + 12} and {nu1Workspace, 5\*u2ModLength + 32}

### 43.3.6.2.7 Status Returned Values

**Table 43-69. ZpEccAddFast Service Return Codes**

Returned Status	Importance	Meaning
PUKCL_OK	–	The computation passed without problem.

### 43.3.6.3 Point Addition and Subtraction

#### 43.3.6.3.1 Purpose

This service is used to perform a point addition and point subtraction, based on a given elliptic curve over GF(p). Please note that:

- This service is not intended to add the same point twice. In this particular case, use the doubling service (see [43.3.6.4 Fast Point Doubling](#)).

#### 43.3.6.3.2 How to Use the Service

#### 43.3.6.3.3 Description

The operation performed is:

$$Pt_C = Pt_A \pm Pt_B$$

In this computation, the following parameters need to be provided:

- A the input point is filled in projective coordinates (X,Y,Z) (pointed by {nu1PointABase, 3\*u2ModLength + 12}). This point can be the Infinite Point.
- B the input point is filled in projective coordinates (X,Y,Z) (pointed by {nu1PointBBase, 3\*u2ModLength + 12}). This point can be the Infinite Point.
- Cns the Fast Modular Constant filled (pointed by {nu1CnsBase,u2ModLength + 8})
- P the modulus filled (pointed by {nu1ModBase,u2ModLength + 4})
- The workspace not initialized (pointed by {nu1WorkSpace, 5\*u2ModLength + 32})
- The operator filled with the operation to perform (Addition or Subtraction)

The resulting C point is represented in projective coordinates (X,Y,Z) and is stored at the very same place than the input point A. This Point can be the Infinite Point.

The service name for this operation is `ZpEccAddSubFast`. This service uses Fast mode and Fast Modular Reduction for computations.

**Note:** Before using this service, ensure that the constant Cns has been calculated with the setup of the modular reduction functions.

#### 43.3.6.3.4 Parameters Definition

**Table 43-70. ZpEccAddSubFast Service Parameters**

Parameter	Type	Direction	Location	Data Length	Before Executing the Service	After Executing the Service
nu1ModBase	nu1	I	Crypto RAM	u2ModLength + 4	Base of Modulus P	Base of Modulus P



# SAM D5x/E5x Family Data Sheet

## Public Key Cryptography Controller (PUKCC)

.....continued

Parameter	Type	Direction	Location	Data Length	Before Executing the Service	After Executing the Service
nu1CnsBase	nu1	I	Crypto RAM	u2ModLength + 8	Base of Cns	Base of Cns
u2ModLength	u2	I	-	-	Length of modulo	Length of modulo
nu1PointABase	nu1	I/O	Crypto RAM	3*u2ModLength + 12	Input point A (projective coordinates)	Resulting point C (projective coordinates)
nu1PointBBase	nu1	I	Crypto RAM	3*u2ModLength + 12	Input point B (projective coordinates)	Input point B
u2Operator	u2	I	-	-	Addition or Subtraction	Addition or Subtraction
nu1Workspace	nu1	I	Crypto RAM	5*u2ModLength + 32	-	Corrupted workspace

### 43.3.6.3.5 Code Example

```

PUKCL_PARAM PUKCLParam;
PUPUKCL_PARAM pvPUKCLParam = &PUKCLParam;

PUKCL (u2Option) = 0;

PUKCL _ZpEccAddSub(nu1ModBase) = <Base of the ram location of P>;
PUKCL _ZpEccAddSub(nu1CnsBase) = <Base of the ram location of Cns>;
PUKCL _ZpEccAddSub(u2ModLength) = <Byte length of P>;
PUKCL _ZpEccAddSub(nu1PointABase) = <Base of the ram location of the A point>;
PUKCL _ZpEccAddSub(nu1PointBBase) = <Base of the ram location of the B point>;
PUKCL _ZpEccAddSub(nu1Workspace) = <Base of the ram location of the workspace>;
PUKCL _ZpEccAddSub(u2Operator) = <Operation to perform (PUKCL_ZPECCADD or PUKCL_ZPECCSUB)>;
...

// vPUKCL_Process() is a macro command, which populates the service name
// and then calls the library...
vPUKCL_Process(ZpEccAddSubFast, &PUKCLParam);
if (PUKCL (u2Status) == PUKCL_OK)
{
    ...
}
else // Manage the error

```

### 43.3.6.3.6 Constraints

No overlapping between either input and output are allowed. The following conditions must be avoided to ensure that the service works correctly:

- nu1ModBase, nu1CnsBase, nu1PointABase, nu1PointBBase, nu1Workspace are not aligned on 32-bit boundaries
- {nu1ModBase, u2ModLength + 4}, {nu1CnsBase, u2ModLength + 8}, {nu1PointABase, 3\*u2ModLength + 12}, {nu1PointBBase, 3\*u2ModLength + 12}, {nu1Workspace, <WorkspaceLength>} are not in Crypto RAM
- u2ModLength is either: < 12, > 0xffc or not a 32-bit length

# SAM D5x/E5x Family Data Sheet

## Public Key Cryptography Controller (PUKCC)

- All overlapping between {nu1ModBase, u2ModLength + 4}, {nu1CnsBase, u2ModLength + 8}, {nu1PointABase, 3\*u2ModLength + 12}, {nu1PointBBase, 3\*u2ModLength + 12} and {nu1Workspace, 5\*u2ModLength + 32}

### 43.3.6.3.7 Status Returned Values

**Table 43-71. ZpEccAddFast Service Return Codes**

Returned Status	Importance	Meaning
PUKCL_OK	–	The computation passed without problem.

### 43.3.6.4 Fast Point Doubling

#### 43.3.6.4.1 Purpose

This service is used to perform a Point Doubling, based on a given elliptic curve over GF(p).

#### 43.3.6.4.2 How to Use the Service

#### 43.3.6.4.3 Description

These two services process the Point Doubling:

$$Pt_C = 2 \times Pt_A$$

In this computation, the following parameters need to be provided:

- A the input point is filled in projective coordinates (X,Y,Z) (pointed by {nu1PointABase, 3\*u2ModLength + 12}). This point can be the Infinite Point.
- Cns the Fast Modular Constant filled (pointed by {nu1CnsBase,u2ModLength + 8})
- P the modulus filled (pointed by {nu1ModBase,u2ModLength + 4})
- The workspace not initialized (pointed by {nu1WorkSpace, 4\*u2ModLength + 28})
- The a parameter relative to the elliptic curve (pointed by {nu1ABase,u2ModLength + 4})
- The resulting C point is represented in projective coordinates (X,Y,Z) and is stored at the same location than the input point A. This point can be the Infinite Point.

The service name for this operation is `ZpEccDblFast`. This service uses Fast mode and Fast Modular Reduction for computations.



**Important:** Before using this service, ensure that the constant Cns has been calculated with the setup of the Fast Modular Reduction service.

#### 43.3.6.4.4 Parameters Definition

**Table 43-72. ZpEccDblFastService**

Parameter	Type	Direction	Location	Data Length	Before Executing the Service	After Executing the Service
nu1ModBase	nu1	I	Crypto RAM	u2ModLength + 4	Base of modulus P	Base of modulus P
nu1CnsBase	nu1	I	Crypto RAM	u2ModLength + 8	Base of Cns	Base of Cns

# SAM D5x/E5x Family Data Sheet

## Public Key Cryptography Controller (PUKCC)

.....continued

Parameter	Type	Direction	Location	Data Length	Before Executing the Service	After Executing the Service
u2ModLength	u2	I	–	–	Length of modulus P	Length of modulus P
nu1ABase	u2	I	Crypto RAM	u2ModLength + 4	Parameter a of the elliptic curve	Parameter a of the elliptic curve
nu1PointABase	nu1	I/O	Crypto RAM	3*u2ModLength + 12	Input point A (projective coordinates)	Resulting point C (projective coordinates)
nu1Workspace	nu1	I	Crypto RAM	4*u2ModLength + 28	–	Corrupted workspace

### 43.3.6.4.5 Code Example

```

PUKCL_PARAM PUKCLParam;
PUPUKCL_PARAM pvPUKCLParam = &PUKCLParam;

PUKCL (u2Option) = 0;

PUKCL _ZpEccDb1(nu1ModBase) = <Base of the ram location of P>;
PUKCL _ZpEccDb1(u2ModLength) = <Byte length of P>;
PUKCL _ZpEccDb1(nu1CnsBase) = <Base of the ram location of Cns>;
PUKCL _ZpEccDb1(nu1PointABase) = <Base of the ram location of the A point>;
PUKCL _ZpEccDb1(nu1ABase) = <Base of the a parameter of the elliptic curve>;
PUKCL _ZpEccDb1(nu1Workspace) = <Base of the ram location of the workspace>;
...

// vPUKCL_Process() is a macro command, which populates the service name
// and then calls the library...
vPUKCL_Process(ZpEccDb1Fast, &PUKCLParam);
if (PUKCL (u2Status) == PUKCL_OK)
{
    ...
}
else // Manage the error

```

### 43.3.6.4.6 Constraints

No overlapping between either input and output are allowed. The following conditions must be avoided to ensure that the service works correctly:

- nu1ModBase, nu1CnsBase, nu1PointABase, nu1ABase, nu1Workspace are not aligned on 32-bit boundaries
- {nu1ModBase, u2ModLength + 4}, {nu1CnsBase, u2ModLength + 8}, {nu1PointABase, 3\*u2ModLength + 12}, {nu1ABase, u2ModLength + 4}, {nu1Workspace, <WorkspaceLength>} are not in Crypto RAM
- u2ModLength is either: < 12, > 0xffc or not a 32-bit length
- All overlapping between {nu1ModBase, u2ModLength + 4}, {nu1CnsBase, u2ModLength + 8}, {nu1PointABase, 3\*u2ModLength + 12}, {nu1ABase, u2ModLength + 4} and {nu1Workspace, 4\*u2ModLength + 28}

# SAM D5x/E5x Family Data Sheet

## Public Key Cryptography Controller (PUKCC)

### 43.3.6.4.7 Status Returned Values

Returned Status	Importance	Meaning
PUKCL_OK	–	The computation passed without problem.

### 43.3.6.5 Fast Multiplying by a Scalar Number of a Point

#### 43.3.6.5.1 Purpose

This service is used to multiply a point by an integral constant K on a given elliptic curve over GF(p).

#### 43.3.6.5.2 How to Use the Service

#### 43.3.6.5.3 Description

These two services process the Multiplying by a scalar number:

$$Pt_C = K \times Pt_A$$

In this computation, the following parameters need to be provided:

- A the input point is filled in projective coordinates (X,Y,Z) (pointed by {nu1PointABase, 3\*u2ModLength + 12}). This point can be the Infinite Point.
- Cns the Fast Modular Constant filled (pointed by {nu1CnsBase,u2ModLength + 8})
- P the modulus filled (pointed by {nu1ModBase,u2ModLength + 4})
- The workspace not initialized (pointed by {nu1WorkSpace, 8\*u2ModLength + 44})
- The a parameter relative to the elliptic curve (pointed by {nu1ABase,u2ModLength + 4})
- K the scalar number (pointed by {nu1ScalarNumber,u2ScalarLength + 4})

The resulting C point is represented in projective coordinates (X,Y,Z) and is stored at the very same place than the input point A. This point can be the Infinite Point.

The service name for this operation is `ZpEccMulFast`. This service uses Fast mode and Fast Modular Reduction for computations.

**Note:** Before using this service, ensure that the constant Cns has been calculated with the setup of the Fast Modular Reduction service.

#### 43.3.6.5.4 Parameters Definition

**Table 43-73. ZpEccMulFast Service Parameters**

Parameter	Type	Direction	Location	Data Length	Before Executing the Service	After Executing the Service
nu1ModBase	nu1	I	Crypto RAM	u2ModLength + 4	Base of modulus P	Base of modulus P
nu1CnsBase	nu1	I	Crypto RAM	u2ModLength + 8	Base of Cns	Base of Cns
u2ModLength	u2	I	–	–	Length of modulus P	Length of modulus P
nu1KBase	nu1	I	Crypto RAM	u2KLength	Scalar number used to multiply the point A	Unchanged

# SAM D5x/E5x Family Data Sheet

## Public Key Cryptography Controller (PUKCC)

.....continued

Parameter	Type	Direction	Location	Data Length	Before Executing the Service	After Executing the Service
u2KLength	u2	I	–	–	Length of scalar K	Length of scalar K
nu1PointABase	nu1	I/O	Crypto RAM	3*u2ModLength + 12	Input point A (projective coordinates)	Resulting point C (projective coordinates)
nu1ABas	nu1	I	Crypto RAM	u2ModLength + 4	Parameter a of the elliptic curve	Unchanged
nu1Workspace	nu1	I	Crypto RAM	8*u2ModLength + 44	–	Corrupted workspace

### 43.3.6.5.5 Code Example

```

PUKCL_PARAM PUKCLParam;
PUPUKCL_PARAM pvPUKCLParam = &PUKCLParam;

PUKCL (u2Option) = 0;

PUKCL _ZpEccMul(nu1ModBase) = <Base of the ram location of P>;
PUKCL _ZpEccMul(u2ModLength) = <Byte length of P>;
PUKCL _ZpEccMul(nu1CnsBase) = <Base of the ram location of Cns>;
PUKCL _ZpEccMul(nu1PointABase) = <Base of the ram location of the A point>;
PUKCL _ZpEccMul(nu1ABase) = <Base of the ram location of the parameter A of the elliptic curve>;
PUKCL _ZpEccMul(nu1KBase) = <Base of the ram location of the scalar number>;
PUKCL _ZpEccMul(nu1Workspace) = <Base of the ram location of the workspace>;
PUKCL _ZpEccMul(u2KLength) = <Byte length of the Scalar Number K>;
...

// vPUKCL_Process() is a macro command, which populates the service name
// and then calls the library...
vPUKCL_Process(ZpEccMulFast,&PUKCLParam);
if (PUKCL (u2Status) == PUKCL_OK)
{
    ...
}
else // Manage the error

```

### 43.3.6.5.6 Constraints

No overlapping between either input and output are allowed. The following conditions must be avoided to ensure that the service works correctly:

- nu1ModBase, nu1CnsBase, nu1PointABase, nu1ABase, nu1ScalarNumber, nu1Workspace are not aligned on 32-bit boundaries
- {nu1ModBase, u2ModLength + 4}, {nu1CnsBase, u2ModLength + 8}, {nu1PointABase, 3\*u2ModLength+ 12}, {nu1ABase, u2ModLength + 4}, {nu1ScalarNumber, u2ScalarLength} or {nu1Workspace, 8\*u2ModLength + 44} are not in Crypto RAM
- u2ModLength is either: < 12, > 0xffc or not a 32-bit length
- All overlapping between {nu1ModBase, u2ModLength + 4}, {nu1CnsBase, u2ModLength + 8}, {nu1PointABase, 3\*u2ModLength + 12}, {nu1ABase, u2ModLength + 4}, {nu1ScalarNumber, u2ScalarLength} and {nu1Workspace, 8\*u2ModLength + 44}

### 43.3.6.5.7 Status Returned Values

Returned Status	Importance	Meaning
PUKCL_OK	–	The computation passed without problem.

### 43.3.6.6 Quick Dual Multiplying by Two Scalar Numbers and Two Points

#### 43.3.6.6.1 Purpose

This service is used to multiply two points by two integral constants K1 and K2, and then provide the addition of these multiplications results.



**Important:** This service has a quick implementation without additional security.

#### 43.3.6.6.2 How to Use the Service

#### 43.3.6.6.3 Description

This service processes the dual Multiplying by two scalar numbers:

$$PtC = K_1 \times Pt_A + K_2 \times Pt_B$$

In this computation, the following parameters need to be provided:

- A the first input point is filled in projective coordinates (X,Y,Z) (pointed by {pu1PointABase, (3\*(u2ModLength + 4)) \* (2(WA-2))}). This point can be the Infinite Point.
- B the 2nd input point is filled in projective coordinates (X,Y,Z) (pointed by {pu1PointBBase, (3\*(u2ModLength + 4)) \* (2(WB-2))}). This point can be the Infinite Point.
- P the modulus filled and Cns the Fast Modular Constant filled (pointed by {pu1ModCnsBase, 2\*u2ModLength + 16})
- The a parameter filled and the workspace not initialized (pointed by {pu1AWorkBase, 9\*u2ModLength + 48})
- KAB the scalar numbers (pointed by {pu1KABBase, 2\*u2KLength + 8})
- The options are set by the u2Options input parameter, which is composed of:
  - wA: Size of window for Point A between 2 and 15
  - wB: Size of window for Point B between 2 and 15
  - PUKCL\_ZPECCMUL\_SCAL\_IN\_CLASSIC\_RAM flag: to set only if the scalars are entirely in Classic RAM with no part in PUKCC RAM

The resulting C point is represented in projective coordinates (X,Y,Z) and is stored at (pu1AWorkBase + u2ModLength + 4). This point can be the Infinite Point.



**Important:** Before using this service, ensure that the constant Cns has been calculated with the setup of the Fast Modular Reduction service.

#### 43.3.6.6.4 Parameters Definition

WA is the Point A window size and WB is the Point B window size (see Options below for details).

# SAM D5x/E5x Family Data Sheet

## Public Key Cryptography Controller (PUKCC)



**Important:** Please calculate precisely the length of areas with the formulas. Ensure that the pu1 type is a pointer on 4 bytes and contains the full address (see [43.3.3.4 Aligned Significant Length](#)).

**Table 43-74. ZpEccQuickDualMulFast Service Parameters**

Parameter	Type	Direction	Location	Data Length	Before Executing the Service	After Executing the Service
pu1ModCnsBase	pu1	I	Crypto RAM	$2 * u2ModLength + 16$	Base of modulus P, Base of Cns	Base of modulus P, Base of Cns
u2Option	u2	I	–	–	Option related to the called service (see below)	–
u2ModLength	u2	I	–	–	Length of modulus P	Length of modulus P
pu1KABBase	pu1	I	Any RAM	$2 * u2KLength + 8$	Scalar numbers used to multiply the points A and B	Unchanged
u2KLength	u2	I	–	–	Length of scalars KA and KB	Length of scalars KA and KB
pu1PointABase	pu1	I/O	Crypto RAM	$(3 * (u2ModLength + 4)) * (2^{(WA-2)}) (1)$	Input point A (projective coordinates)	Unchanged
pu1PointBBase	pu1	I	Crypto RAM	$(3 * (u2ModLength + 4)) * (2^{(WB-2)}) (2)$	Input point B (projective coordinates)	Unchanged
pu1AWorkBase	pu1	I	Crypto RAM	$9 * u2ModLength + 48$	Parameter a of the elliptic curve	Resulting point C (projective coordinates) in pu1AWorkBase Base + u2ModLength + 4

**Note:**

1. The precalculus table size for the point A is calculated from chosen window size “WA”.
2. The precalculus table size for the point B is calculated from chosen window size “WB”.

**43.3.6.6.5 Options**

The options are set by the u2Options input parameter, which is composed of:

- the mandatory windows sizes WA and WB

# SAM D5x/E5x Family Data Sheet

## Public Key Cryptography Controller (PUKCC)

- the indication of the presence of the scalars in system RAM

**Note:** Please check precisely if one part of the scalars is in Crypto RAM. If this is the case, the PUKCL\_ZPECCMUL\_SCAL\_IN\_CLASSIC\_RAM option must not be used.

The u2Options number is calculated by an “Inclusive OR” of the options. Some Examples in C language are:

- ```
// Scalars are in system RAM
// The Point A window size is 3
// The Point B window size is 4

PUKCL(u2Options) = PUKCL_ZPECCMUL_SCAL_IN_CLASSIC_RAM |
PUKCL_ZPECCMUL_WINSIZE_A_VAL_TO_OPT(3) |
PUKCL_ZPECCMUL_WINSIZE_B_VAL_TO_OPT(4);
```
- ```
// Scalars are in the PUKCC Cryptographic RAM
// The Point A window size is 2
// The Point B window size is 5

PUKCL(u2Options) = PUKCL_ZPECCMUL_WINSIZE_A_VAL_TO_OPT(2) |
PUKCL_ZPECCMUL_WINSIZE_B_VAL_TO_OPT(5);
```

For this service, many window sizes are possible. The window sizes in bits are those of the windowing method used for the scalar multiplying.

The choice of the window sizes is a balance between the size of the parameters and the computation time:

- Increasing the window size increases the precomputation table size.
- Increasing the window size to the optimum reduces the computation time.

The following table details the size of the point and the precomputation table, depending on the chosen window size option.

**Table 43-75. ZpEccQuickDualMulFast Service Window Size Options and Precomputation Table Size**

Option Specified	Size of the Point and the Precomputation Table
PUKCL_ZPECCMUL_WINSIZE_A_VAL_TO_OPT(WA) WA in [2, 15]	$(3*(u2ModLength + 4)) * (2^{(WA-2)})$
PUKCL_ZPECCMUL_WINSIZE_B_VAL_TO_OPT(WB) WB in [2, 15]	$(3*(u2ModLength + 4)) * (2^{(WB-2)})$

The scalars can be located in PUKCC RAM or in system RAM. If both scalars are entirely in system RAM with no part in PUKCC RAM this can be signaled by using the option PUKCL\_ZPECCMUL\_SCAL\_IN\_CLASSIC\_RAM. In all other cases this option must not be used.

The following table describes this option.



# SAM D5x/E5x Family Data Sheet

## Public Key Cryptography Controller (PUKCC)

**Table 43-76. ZpEccQuickDualMulFast Service System RAM Scalar Options**

Option	Purpose
PUKCL_ZPECCMUL_SCAL_IN_CLASSIC_RAM	<p>The scalars can be located in Crypto RAM or in system RAM.</p> <p>If both scalars are entirely in system RAM with no part in Crypto RAM this can be signaled by using this option . In all other cases this option must not be used.</p>

### 43.3.6.6.6 Code Example

```

PUKCL_PARAM PUKCLParam;
PUPUKCL_PARAM pvPUKCLParam = &PUKCLParam;

PUKCL(u2Option) = <Configure scalar numbers location and windows sizes>;
PUKCL_ZpEccQuickDualMulFast(pu1ModCnsBase) = <Base of the ram location of P and Cns>;
PUKCL_ZpEccQuickDualMulFast(u2ModLength) = <Byte length of P>;
PUKCL_ZpEccQuickDualMulFast(u2KLength) = <Byte length of scalars>;
PUKCL_ZpEccQuickDualMulFast(pu1PointABase) = <Base of the ram location of the A point>;
PUKCL_ZpEccQuickDualMulFast(pu1PointBBase) = <Base of the ram location of the B point>;
PUKCL_ZpEccQuickDualMulFast(pu1AWorkBase) = <Base of the ram location of the parameter A of
the elliptic curve and workspace>;
PUKCL_ZpEccQuickDualMulFast(pu1KABBase) = <Base of the ram location of the scalar numbers KA
and KB>;
...

// vPUKCL_Process() is a macro command, which populates the service name
// and then calls the library...
vPUKCL_Process(ZpEccQuickDualMulFast, pvPUKCLParam);
if (PUKCL(u2Status) == PUKCL_OK)
{
    ...
}
else // Manage the error

```

### 43.3.6.6.7 Constraints

No overlapping between either input and output are allowed. The following conditions must be avoided to ensure that the service works correctly:

- pu1ModCnsBase, pu1PointABase, pu1PointBBase, pu1AWorkBase, pu1KABBase are not aligned on 32-bit boundaries
- {pu1ModCnsBase, 2\*u2ModLength + 16}, {pu1PointABase, (3\*(u2ModLength + 4)) \* (2<sup>(WA-2)</sup>)}, {pu1PointBBase, (3\*(u2ModLength + 4)) \* (2<sup>(WB-2)</sup>)} or { pu1AWorkBase, 9\*u2ModLength + 48} are not in PUKCC RAM
- u2ModLength is either: < 12, > 0xffc or not a 32-bit length
- All overlapping between {pu1ModCnsBase, 2\*u2ModLength + 16}, {pu1PointABase, (3\*(u2ModLength + 4)) \* (2<sup>(WA-2)</sup>)}, {pu1PointBBase, (3\*(u2ModLength + 4)) \* (2<sup>(WB-2)</sup>)} or {pu1AWorkBase, 9\*u2ModLength + 48}.

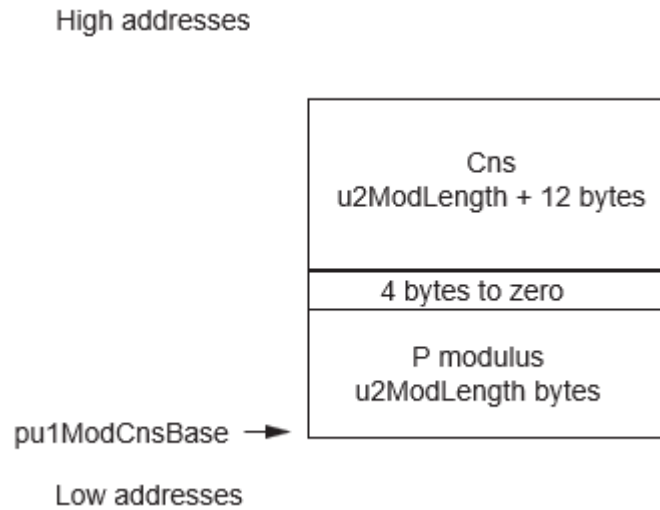
### 43.3.6.6.8 Parameters Placement

The parameters' placement is described in the following figures.

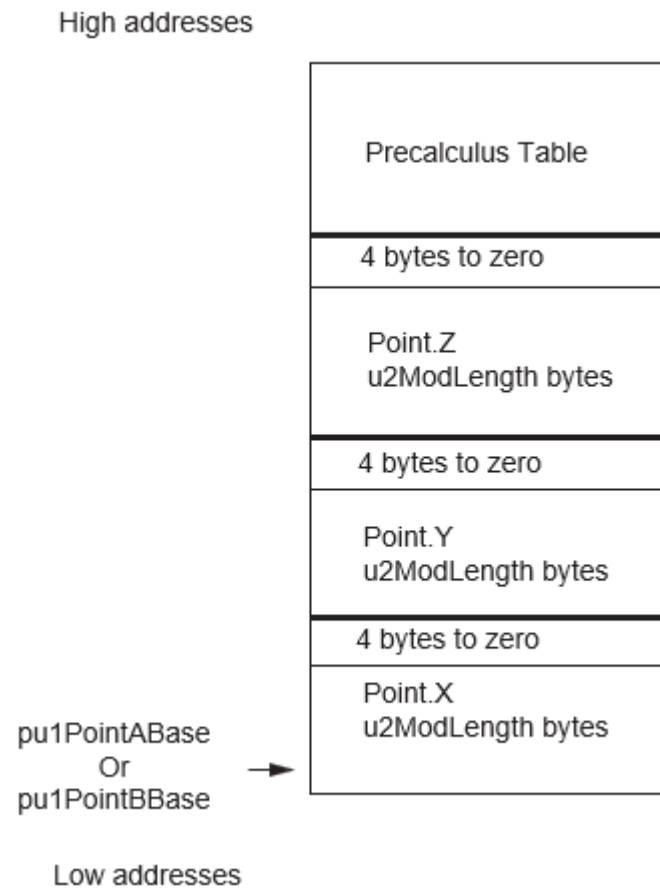
# SAM D5x/E5x Family Data Sheet

## Public Key Cryptography Controller (PUKCC)

**Figure 43-7. Modulus P and Cns{pu1ModCnsBase, 2\*u2ModLength + 16}**



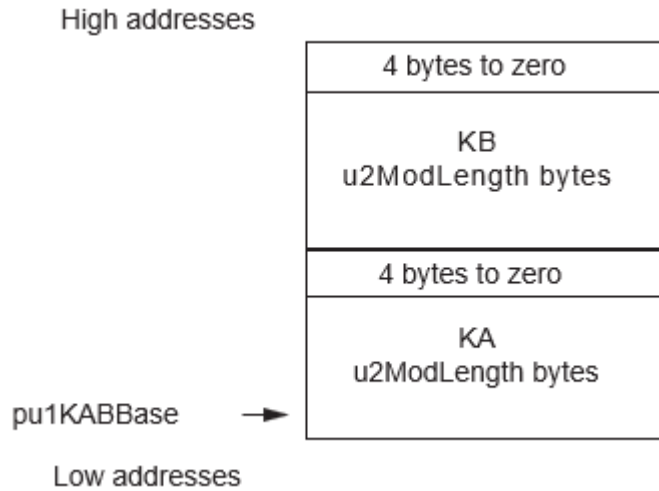
**Figure 43-8. Points A and B {pu1PointABase, [(3\*(u2ModLength + 4)) \* (2<sup>(WA-2)</sup>)] Or [(3\*(u2ModLength + 4)) \* (2<sup>(WB-2)</sup>)]}**



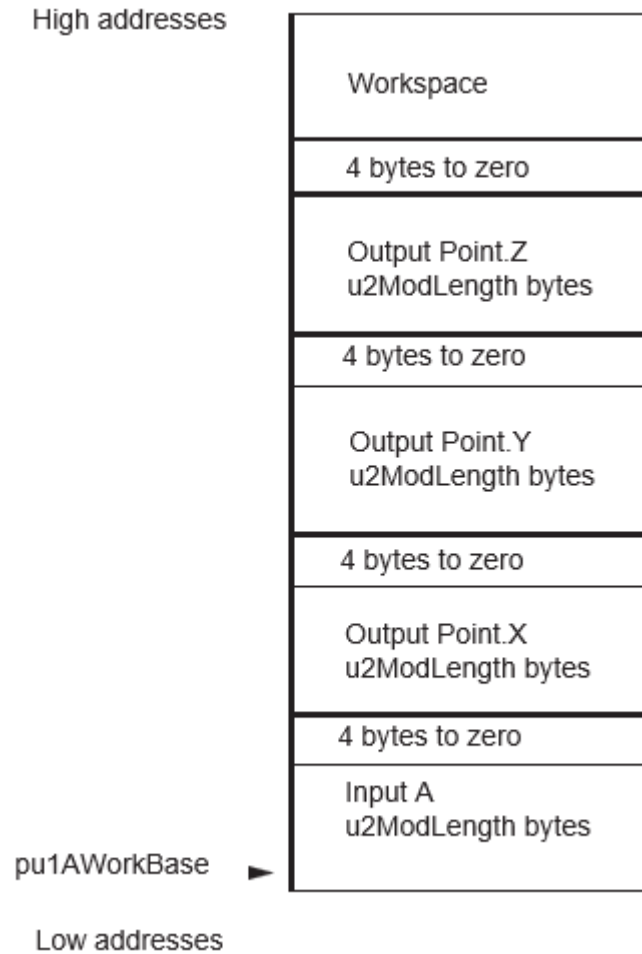
# SAM D5x/E5x Family Data Sheet

## Public Key Cryptography Controller (PUKCC)

**Figure 43-9. Scalars KA and KB {pu1KABBase, 2 \* u2KLength + 8}**



**Figure 43-10. The a parameter and Workspace {pu1AWorkBase, 9\*u2ModLength + 48}**



# SAM D5x/E5x Family Data Sheet

## Public Key Cryptography Controller (PUKCC)

### 43.3.6.6.9 Status Returned Values

Returned Status	Importance	Meaning
PUKCL_OK	–	The computation passed without problem.

### 43.3.6.7 Projective to Affine Coordinates Conversion

#### 43.3.6.7.1 Purpose

This service is used to perform a point coordinates conversion from projective representation to affine.

#### 43.3.6.7.2 How to Use the Service

#### 43.3.6.7.3 Description

The operation performed is:

$$Pt_X \text{ Affine coordinate} = \left[ \frac{Pt_X \text{ Projective coordinate}}{(Pt_Z \text{ Projective coordinate})^2} \right]$$

$$Pt_Y \text{ Affine coordinate} = \left[ \frac{Pt_Y \text{ Projective coordinate}}{(Pt_Z \text{ Projective coordinate})^3} \right]$$

In this computation, the following parameters need to be provided:

- A the input point is filled in projective coordinates (X,Y,Z) or affine coordinates for X and Y, and setting Z to 1 (pointed by {nu1PointABase, 3\*u2ModLength + 12}). The Point A can be the point at infinity. In this case, the u2Status returned is PUKCL\_POINT\_AT\_INFINITY.
- Cns the Fast Modular Constant filled (pointed by {nu1CnsBase, u2ModLength + 8})
- P the modulus filled (pointed by {nu1ModBase, u2ModLength + 4})
- The workspace not initialized (pointed by {nu1WorkSpace, 4\*u2ModLength + 48})

The result is the point A with its (X,Y) coordinates converted to affine, and the Z coordinate set to 1. The service for this operation is ZpEcConvProjToAffine.



**Important:** Before using this service, ensure that the constant Cns has been calculated with the Setup of the fast Modular Reductions service.

### 43.3.6.7.4 Parameters Definition

**Table 43-77. ZpEcConvAffineToProjective Service Parameters**

Parameter	Type	Direction	Location	Data Length	Before Executing the Service	After Executing the Service
nu1ModBase	nu1	I	Crypto RAM	u2ModLength + 4	Base of modulus P	Base of modulus P
nu1CnsBase	nu1	I	Crypto RAM	u2ModLength + 8	Base of Cns	Base of Cns
u2ModLength	u2	I	–	–	Length of modulus P	Length of modulus P

# SAM D5x/E5x Family Data Sheet

## Public Key Cryptography Controller (PUKCC)

.....continued

Parameter	Type	Direction	Location	Data Length	Before Executing the Service	After Executing the Service
nu1PointABase	nu1	I	Crypto RAM	3*u2ModLength + 12	Input point A	Resulting point A in affine coordinates
nu1Workspace	nu1	I	Crypto RAM	4*u2ModLength + 48	–	Workspace

### 43.3.6.7.5 Code Example

```

PUKCL_PARAM PUKCLParam;
PUPKCL_PARAM pvPUKCLParam = &PUKCLParam;

PUKCL (u2Option) = 0;

PUKCL _ZpEcConvProjToAffine(nu1ModBase) = <Base of the ram location of P>;
PUKCL _ZpEcConvProjToAffine(u2ModLength) = <Byte length of P>;
PUKCL _ZpEcConvProjToAffine(nu1CnsBase) = <Base of the ram location of Cns>;
PUKCL _ZpEcConvProjToAffine(nu1PointABase) = <Base of the ram location of the A point>;
PUKCL _ZpEcConvProjToAffine(nu1Workspace) = <Base of the ram location of the workspace>;
...

// vPUKCL_Process() is a macro command, which populates the service name
// and then calls the library...
vPUKCL_Process(ZpEcConvProjToAffine,&PUKCLParam);
if (PUKCL (u2Status) == PUKCL_OK)
{
    ...
}
else // Manage the error

```

### 43.3.6.7.6 Constraints

No overlapping between either input and output are allowed. The following conditions must be avoided to ensure that the service works correctly:

- nu1ModBase, nu1CnsBase, nu1PointABase, nu1Workspace are not aligned on 32-bit boundaries
- {nu1ModBase, u2ModLength + 4}, {nu1CnsBase, u2ModLength + 8}, {nu1PointABase, 3\*u2ModLength+ 12}, {nu1Workspace, <WorkspaceLength>} are not in Crypto RAM
- u2ModLength is either: < 12, > 0xffc or not a 32-bit length
- All overlapping between {nu1ModBase, u2ModLength + 4}, {nu1CnsBase, u2ModLength +8},

{nu1PointABase, 3\*u2ModLength + 12} and {nu1Workspace, 4\*u2ModLength + 48}

### 43.3.6.7.7 Status Returned Values

**Table 43-78. ZpEccConvAffineToProjective Service Return Codes**

Returned Status	Importance	Meaning
PUKCL_OK	–	The computation passed without problem.
PUKCL_POINT_AT_INFINITY	Warning	The input point has its Z equal to zero, so it's a representation of the infinite point.

# SAM D5x/E5x Family Data Sheet

## Public Key Cryptography Controller (PUKCC)

### 43.3.6.8 Affine to Projective Coordinates Conversion

#### 43.3.6.8.1 Purpose

This service is used to perform a point coordinates conversion from an affine point representation to projective.

#### 43.3.6.8.2 How to Use the Service

#### 43.3.6.8.3 Description

The operation performed is:

$$\text{affine}(X_a, Y_a) \rightarrow \text{projective}(X_p, Y_p, Z_p)$$

In this computation, the following parameters need to be provided:

- A the input point is filled in affine coordinates for X and Y, and setting Z to 1 (pointed by {nu1PointABase, 3\*u2ModLength + 4}).
- Cns the Fast Modular Constant filled (pointed by {nu1CnsBase, u2ModLength + 8})
- P the modulus filled (pointed by {nu1ModBase, u2ModLength + 4})
- The workspace not initialized (pointed by {nu1WorkSpace, 2\*u2ModLength + 16})

The result is the point A with its (X,Y,Z) projective coordinates.

The service for this operation is ZpEccConvAffineToProjective



**Important:** Before using this service, ensure that the constant Cns has been calculated with the setup of the Fast Modular Reductions service.

#### 43.3.6.8.4 Parameters Definition

**Table 43-79. ZpEccConvAffineToProjective Service Parameters**

Parameter	Type	Direction	Location	Data Length	Before Executing the Service	After Executing the Service
nu1ModBase	nu1	I	Crypto RAM	u2ModLength + 4	Base of modulus P	Base of modulus P
nu1CnsBase	nu1	I	Crypto RAM	u2ModLength + 8	Base of Cns	Base of Cns
u2ModLength	u2	I	–	–	Length of modulus P	Length of modulus P
nu1PointABase	nu1	I	Crypto RAM	3*u2ModLength + 12	Input point A	Resulting point A in affine coordinates
nu1Workspace	nu1	I	Crypto RAM	2*u2ModLength + 16	–	Workspace

#### 43.3.6.8.5 Code Example

```
PUKCL_PARAM PUKCLParam;
PPUKCL_PARAM pvPUKCLParam = &PUKCLParam;
```

# SAM D5x/E5x Family Data Sheet

## Public Key Cryptography Controller (PUKCC)

```

PUKCL (u2Option) = 0;

PUKCL _ZpEcConvAffineToProjective(nu1ModBase) = <Base of the ram location of P>;
PUKCL _ZpEcConvAffineToProjective(u2ModLength) = <Byte length of P>;
PUKCL _ZpEcConvAffineToProjective(nu1CnsBase) = <Base of the ram location of Cns>;
PUKCL _ZpEcConvAffineToProjective(nu1PointABase) = <Base of the ram location of the A point>;
PUKCL _ZpEcConvAffineToProjective(nu1Workspace) = <Base of the ram location of the workspace>;
...

// vPUKCL_Process() is a macro command, which populates the service name
// and then calls the library...
vPUKCL_Process(ZpEcConvAffineToProjective,&PUKCLParam);
if (PUKCL (u2Status) == PUKCL_OK)
    {
        ...
    }
else // Manage the error

```

### 43.3.6.8.6 Constraints

No overlapping between either input and output are allowed. The following conditions must be avoided to ensure that the service works correctly:

- nu1ModBase, nu1CnsBase, nu1PointABase, nu1Workspace are not aligned on 32-bit boundaries
- {nu1ModBase, u2ModLength + 4}, {nu1CnsBase, u2ModLength + 8}, {nu1PointABase, 3\*u2ModLength+ 12}, {nu1Workspace, <WorkspaceLength>} are not in Crypto RAM
- u2ModLength is either: < 12, > 0xffc or not a 32-bit length
- All overlapping between {nu1ModBase, u2ModLength + 4}, {nu1CnsBase, u2ModLength +8}, {nu1PointABase, 3\*u2ModLength + 12}, and {nu1Workspace, 2\*u2ModLength + 16}

### 43.3.6.8.7 Status Returned Values

**Table 43-80. ZpEccConvAffineToProjective Service Return Codes**

Returned Status	Importance	Meaning
PUKCL_OK	–	The computation passed without problem.

### 43.3.6.9 Randomize a Coordinate

#### 43.3.6.9.1 Purpose

This service is used to convert the projective representation of a point to another projective representation.

#### 43.3.6.9.2 How to Use the Service

#### 43.3.6.9.3 Description

The operation performed is:

$$Projective(X_1, Y_1, Z_1) \rightarrow Projective(X_2, Y_2, Z_2)$$

In this computation, the following parameters need to be provided:

- The input point is filled in projective coordinates (X,Y,Z) (pointed by {nu1PointBase,3\*u2ModLength + 12}). This Point must not be the point at infinity.
- Cns the Fast Modular Constant filled (pointed by {nu1CnsBase,u2ModLength +8})
- P the modulus filled (pointed by {nu1ModBase,u2ModLength +4})
- The workspace not initialized (pointed by {nu1WorkSpace, 3\*u2ModLength +28})
- The random number (pointed by {nu1RandomBase, u2ModLength +4}).

The result is the point nu1PointBase with its (X,Y,Z) coordinates randomized.

The service for this operation is ZpEcRandomiseCoordinate.

# SAM D5x/E5x Family Data Sheet

## Public Key Cryptography Controller (PUKCC)



**Important:** Before using this service:

- Ensure that the constant Cns has been calculated with the setup of the Modular Reduction service.
- Be sure to follow the directives given for the RNG on the chip you use (particularly initialization, seeding) and compulsorily start the RNG

### 43.3.6.9.4 Parameters Definition

**Table 43-81. ZpEccRandomiseCoordinate Service Parameters**

Parameter	Type	Direction	Location	Data Length	Before Executing the Service	After Executing the Service
nu1ModBase	nu1	I	Crypto RAM	u2ModLength + 4	Base of modulus P	Base of modulus P
nu1CnsBase	nu1	I	Crypto RAM	u2ModLength + 8	Base of Cns	Base of Cns
u2ModLength	u2	I	–	–	Length of modulus P	Length of modulus P
nu1PointBase	nu1	I	Crypto RAM	3*u2ModLength + 12	Input point	Resulting point
nu1RandomBase	nu1	I	Crypto RAM	u2ModLength + 4	Random	Corrupted
nu1Workspace	nu1	I	Crypto RAM	3*u2ModLength + 28	–	Workspace

### 43.3.6.9.5 Code Example

```

PUKCL_PARAM PUKCLParam;
PUPKCL_PARAM pvPUKCLParam = &PUKCLParam;

// ! The Random Number Generator must be initialized and started
// ! following the directives given for the RNG on the chip

PUKCL (u2Option) = 0;

// Depending on the option specified, not all fields should be filled
PUKCL _ZpEccRandomiseCoordinate(nu1ModBase) = <Base of the ram location of P>;
PUKCL _ZpEccRandomiseCoordinate(u2ModLength) = <Byte length of P>;
PUKCL _ZpEccRandomiseCoordinate(nu1CnsBase) = <Base of the ram location of Cns>;
PUKCL _ZpEccRandomiseCoordinate(nu1RandomBase) = <Base of the ram location where the the RNG
is stored>;
PUKCL _ZpEccRandomiseCoordinate(nu1PointBase) = <Base of the ram location of the point>;
PUKCL _ZpEccRandomiseCoordinate(nu1Workspace) = <Base of the ram location of the workspace>;
...

// vPUKCL_Process() is a macro command, which populates the service name
// and then calls the library...
vPUKCL_Process(ZpEccRandomiseCoordinate, &PUKCLParam);
if (PUKCL (u2Status) == PUKCL_OK)
{
    ...
}
else // Manage the error

```



# SAM D5x/E5x Family Data Sheet

## Public Key Cryptography Controller (PUKCC)

### 43.3.6.9.6 Constraints

No overlapping between either input and output are allowed. The following conditions must be avoided to ensure that the service works correctly:

- nu1ModBase, nu1CnsBase, nu1PointABase, nu1RandomBase, nu1Workspace are not aligned on 32-bit boundaries
- {nu1ModBase, u2ModLength + 4}, {nu1CnsBase, u2ModLength + 8}, {nu1PointABase, 3\*u2ModLength + 12}, {nu1RandomBase, u2ModLength + 4}, {nu1Workspace, <WorkspaceLength>} are not in Crypto RAM
- u2ModLength is either: < 12, > 0xffc or not a 32-bit length
- All overlapping between {nu1ModBase, u2ModLength + 4}, {nu1CnsBase, u2ModLength + 8}, {nu1PointABase, 3\*u2ModLength + 12}, {nu1RandomBase, u2ModLength + 4} and {nu1Workspace, 3\*u2ModLength + 28}

### 43.3.6.9.7 Status Returned Values

**Table 43-82. ZpEccRandomiseCoordinate Service Return Codes**

Returned Status	Importance	Meaning
PUKCL_OK	–	The computation passed without problem.

### 43.3.6.10 Point is on Elliptic Curve

#### 43.3.6.10.1 Purpose

This service is used to test whether or not the point is on the curve.

#### 43.3.6.10.2 How to Use the Service

#### 43.3.6.10.3 Description

The operation performed is:

$$Status = IsPointOnCurve(X, Y, Z)$$

In this computation, the following parameters need to be provided:

- The input point is filled in projective coordinates (X,Y,Z) (pointed by {nu1PointBase,3\*u2ModLength + 4}). This Point can be the point at infinity.
- AParam and BParam are the Elliptic Curve Equation parameters. (pointed by {nu1AParam, u2ModLength+4} and {nu1BParam, u2ModLength+4}).
- Cns the Fast Modular Constant filled (pointed by {nu1CnsBase,u2ModLength+8}).
- P the modulus filled (pointed by {nu1ModBase,u2ModLength +4}).
- The workspace not initialized (pointed by {nu1WorkSpace, 4\*u2ModLength +28}).

The result is the status of the point (X,Y,Z) regarding the Elliptic Curve Equation.

The service name for this operation is ZpEcPointIsOnCurve.

**Note:** Before using this service, ensure that the constant Cns has been calculated with the setup of the Fast Modular Reduction service.

#### 43.3.6.10.4 Parameters Definition

**Table 43-83. ZpEcPointIsOnCurve Service Parameters**

Parameter	Type	Direction	Location	Data Length	Before Executing the Service	After Executing the Service

# SAM D5x/E5x Family Data Sheet

## Public Key Cryptography Controller (PUKCC)

nu1ModBase	nu1	l	Crypto RAM	u2ModLength + 4	Base of modulus P	Base of modulus P
nu1CnsBase	nu1	l	Crypto RAM	u2ModLength + 8	Base of Cns	Base of Cns
u2ModLength	u2	l	–	–	Length of modulus P	Length of modulus P
nu1PointBase	nu1	l	Crypto RAM	3*u2ModLength + 12	Input point	unchanged
nu1AParam	nu1	l	Crypto RAM	u2ModLength + 4	The parameter a	The parameter a
nu1BParam	nu1	l	Crypto RAM	u2ModLength + 4	The parameter b	The parameter b
nu1Workspace	nu1	l	Crypto RAM	4*u2ModLength + 28	–	Workspace

### 43.3.6.10.5 Code Example

```

PUKCL_PARAM PUKCLParam;
PPUKCL_PARAM pvPUKCLParam = &PUKCLParam;

PUKCL (u2Option) = 0;

PUKCL _ZpEcPointIsOnCurve(nu1ModBase) = <Base of the ram location of P>;
PUKCL _ZpEcPointIsOnCurve(u2ModLength) = <Byte length of P>;
PUKCL _ZpEcPointIsOnCurve(nu1CnsBase) = <Base of the ram location of Cns>;
PUKCL _ZpEcPointIsOnCurve(nu1AParam) = <Base of the ram location of the parameter a>;
PUKCL _ZpEcPointIsOnCurve(nu1BParam) = <Base of the ram location of the parameter b>;
PUKCL _ZpEcPointIsOnCurve(nu1PointBase) = <Base of the ram location of the point>;
PUKCL _ZpEcPointIsOnCurve(nu1Workspace) = <Base of the ram location of the workspace>;
...

// vPUKCL_Process() is a macro command, which populates the service name
// and then calls the library...
vPUKCL_Process(ZpEcPointIsOnCurve, &PUKCLParam);
if (PUKCL (u2Status) == PUKCL_OK)
{
    ...
}
else // Manage the error

```

### 43.3.6.10.6 Constraints

No overlapping between either input and output are allowed. The following conditions must be avoided to ensure that the service works correctly:

- nu1ModBase, nu1CnsBase, nu1PointABase, nu1AParam, nu1BParam, nu1Workspace are not aligned on 32-bit boundaries
- {nu1ModBase, u2ModLength+4}, {nu1CnsBase, u2ModLength+8}, {nu1PointABase, 3\*u2ModLength+12}, {nu1AParam, u2ModLength+4}, {nu1BParam, u2ModLength+4}, {nu1Workspace, <WorkspaceLength>} are not in Crypto RAM.
- u2ModLength is either: < 12, > 0xffc or not a 32-bit length.
- All overlapping between {nu1ModBase, u2ModLength+4}, {nu1CnsBase, u2ModLength+8}, {nu1PointABase, 3\*u2ModLength+12}, {nu1AParam, u2ModLength+4}, {nu1AParam, u2ModLength+4} and {nu1Workspace, 4\*u2ModLength+28}.

# SAM D5x/E5x Family Data Sheet

## Public Key Cryptography Controller (PUKCC)

### 43.3.6.10.7 Status Returned Values

**Table 43-84. ZpEcPointIsOnCurve Service Return Codes**

Returned Status	Importance	Meaning
PUKCL_OK	–	The point is on the curve.
PUKCL_POINT_IS_NOT_ON_CURVE	Warning	The point is not on the curve.
PUKCL_POINT_AT_INFINITY	Warning	The input point has its Z equal to zero, so it's a representation of the infinite point.

### 43.3.6.11 Generating an ECDSA Signature (Compliant with FIPS 186-2)

#### 43.3.6.11.1 Purpose

This service is used to generate an ECDSA signature following the FIPS 186-2. It performs the second step of the Signature Generation. A hash value (*HashVal*) must be provided as input, it has to be previously computed from the message to be signed using a secure hash algorithm.

A scalar number must be provided too as described in the FIPS 186-2. The result (R,S) is computed by this service.

#### 43.3.6.11.2 How to Use the Service

#### 43.3.6.11.3 Description

The operation performed is:

$$(R, S) = EcDsaSign(Pt_A, HashVal, k, CurveParameters, PrivateKey)$$

This service processes the following checks:

- If the Scalar Number *k* is out of the range [1, PointOrder -1], the calculus is stopped and the status is set to PUKCL\_WRONG\_SELECT\_NUMBER.
- If *R* equals zero, the calculus is stopped and the status is set to PUKCL\_WRONG\_SELECT\_NUMBER.
- If *S* equals zero, the calculus is stopped and the status is set to PUKCL\_WRONG\_SELECT\_NUMBER.

In this computation, the following parameters need to be provided:

- *A* the input point is filled in “mixed” coordinates (X,Y) with the affine values and *Z* = 1 (pointed by {nu1PointABase, 3\*u2ModLength + 12})
- *Cns* the working space for the Fast Modular Constant not initialized (pointed by {nu1CnsBase, u2ScalarLength + 8})
- *P* the modulus filled (pointed by {nu1ModBase, u2ModLength + 4})
- The workspace not initialized (pointed by {nu1WorkSpace, 8\*u2ModLength + 44})
- The *a* parameter relative to the elliptic curve (pointed by {nu1ABase, u2ModLength + 4})
- The order of the Point *A* on the elliptic curve (pointed by {nu1OrderPointBase, u2ScalarLength + 4})
- *k* the input Scalar Number beforehand generated and filled (pointed by {nu1ScalarNumber, u2ScalarLength + 4})
- *HashVal* the hash value beforehand generated and filled (pointed by {nu1HashBase, u2ScalarLength + 4})
- The Private Key (pointed by {nu1PrivateKey, u2ScalarLength + 4})

# SAM D5x/E5x Family Data Sheet

## Public Key Cryptography Controller (PUKCC)

- Generally, `u2ScalarLength` is equal to `(u2ModLength)` or `(u2ModLength + 4)`



**Important:**

For the ECDSA signature generation be sure to follow the directives given for the RNG on the chip you use (particularly initialization, seeding) and compulsorily start the RNG.

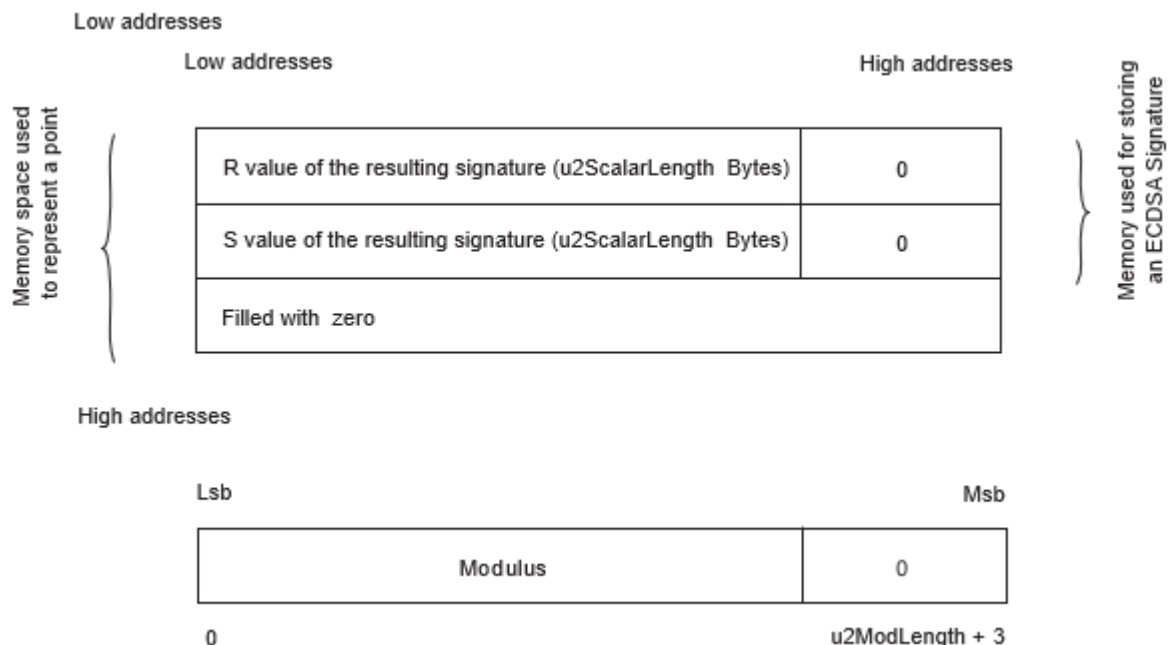
The scalar number `k` must be selected at random. This random must be generated before the call of the ECDSA signature. For this random generation be sure to follow the directives given for the RNG on the chip you use (particularly initialization, seeding) and compulsorily start the RNG.

The operation performed is:

- Compute the ECDSA (R,S) as described in FIPS 186-2, but leaving the user the role of computing the input Hash Value, thus leaving the freedom of using any other algorithm than SHA-1.
- Compute a R value using the input A point and the scalar number.
- Compute a S value using R, the scalar number, the private key and the provided hash value. Note that the resulting signature (R,S) is stored at the place of the input A point.
- If all is correct and S is different from zero, the status is set to `PUKCL_OK`. If all is correct and S equals zero, the status is set to `PUKCL_WRONG_SELECT_NUMBER`. If an error occurs, the status is set to the corresponding error value (see Status Returned Values below).

The service name for this operation is `ZpEcDsaGenerateFast`. This service uses Fast mode and Fast Modular Reduction for computation.

- The signature (R,S), when resulting from a computation is given back at address of the A point:
  - R output is at offset 0 and has length `(u2ScalarLength + 4)` bytes.
  - S output is at offset `(u2ScalarLength + 4)` bytes and has length `(u2ScalarLength + 4)` bytes.
  - The MSB 4 zero bytes may be suppressed to get the R and S values on `u2ScalarLength` bytes



# SAM D5x/E5x Family Data Sheet

## Public Key Cryptography Controller (PUKCC)

### 43.3.6.11.4 Parameters Definition

**Table 43-85. ZpEcDsaGenerateFast Service Parameters**

Parameter	Type	Direction	Location	Data Length	Before Executing the Service	After Executing the Service
nu1ModBase	nu1	I	Crypto RAM	u2ModLength + 4	Base of modulus P	Base of modulus P
nu1CnsBase	nu1	I	Crypto RAM	u2ScalarLength + 8	Base of Cns	Base of Cns
u2ModLength	u2	I	–	–	Length of modulus P	Length of modulus P
nu1ScalarNumber	nu1	I	Crypto RAM	u2ScalarLength + 4	Scalar Number used to multiply the point A	Unchanged
nu1OrderPointBase	nu1	I	Crypto RAM	u2ScalarLength + 4	Order of the Point A in the elliptic curve	Unchanged
nu1PrivateKey	nu1	I/O	Crypto RAM	u2ScalarLength + 4	Base of the Private Key	Unchanged
nu1HashBase (see <b>Note 1</b> )	nu1	I	Crypto RAM	u2ScalarLength + 4	Base of the hash value resulting from the previous SHA	Unchanged
u2ScalarLength	u2	I	–	–	Length of scalar (same length as the length of order)	Length of scalar
nu1PointABase (see <b>Note 2</b> )	nu1	I/O	Crypto RAM	3*u2ModLength + 12	Input point A (three coordinates (X,Y) affine and Z = 1)	Resulting signature (R,S,0)
nu1ABase	nu1	I	Crypto RAM	u2ModLength + 4	Parameter a of the elliptic curve	Unchanged
nu1Workspace	nu1	I	Crypto RAM	8*u2ModLength + 44	–	Corrupted workspace

**Note:**

1. The hash value calculus is defined by the ECDSA norm and depends on the elliptic curve domain parameters. To construct the input parameter, the 4 Most Significant Bytes must be set to zero.
2. The resulting signature format is different from the point A format (see Description above for information on the point A format).

# SAM D5x/E5x Family Data Sheet

## Public Key Cryptography Controller (PUKCC)

### 43.3.6.11.5 Code Example

```

PUKCL_PARAM PUKCLParam;
P_PUKCL_PARAM pvPUKCLParam = &PUKCLParam;

// ! The Random Number Generator must be initialized and started
// ! following the directives given for the RNG on the chip

PUKCL (u2Option) = 0;

// Depending on the option specified, not all fields should be filled
PUKCL_ZpEcDsaGenerate(nu1ModBase) = <Base of the ram location of P>; PUKCL
_ZpEcDsaGenerate(u2ModLength) = <Byte length of P>;
PUKCL_ZpEcDsaGenerate(nu1CnsBase) = <Base of the ram location of Cns>;
PUKCL_ZpEcDsaGenerate(nu1PointABase) = <Base of the A point>;
PUKCL_ZpEcDsaGenerate(nu1PrivateKey) = <Base of the Private Key>;
PUKCL_ZpEcDsaGenerate(nu1ScalarNumber) = <Base of the ScalarNumber>;
PUKCL_ZpEcDsaGenerate(nu1OrderPointBase) = <Base of the order of A point>;
PUKCL_ZpEcDsaGenerate(nu1ABase) = <Base of the a parameter of the curve>;
PUKCL_ZpEcDsaGenerate(nu1Workspace) = <Base of the workspace>;
PUKCL_ZpEcDsaGenerate(nu1HashBase) = <Base of the SHA resulting hash>;
PUKCL_ZpEcDsaGenerate(u2ScalarLength) = <Length of ScalarNumber>;
...

// vPUKCL_Process() is a macro command, which populates the service name
// and then calls the library...
vPUKCL_Process(ZpEcDsaGenerateFast, pvPUKCLParam);
if (PUKCL (u2Status) == PUKCL_OK)
{
    ...
}
else // Manage the error

```

### 43.3.6.11.6 Constraints

No overlapping between either input and output are allowed. The following conditions must be avoided to ensure that the service works correctly:

- nu1ModBase, nu1CnsBase, nu1PointABase, nu1PrivateKey, nu1ScalarNumber, nu1OrderPointBase, nu1ABase, nu1Workspace or nu1HashBase are not aligned on 32-bit boundaries
- {nu1ModBase, u2ModLength + 4}, {nu1CnsBase, u2ModLength + 8}, {nu1PointABase, 3\*u2ModLength + 12}, {nu1PrivateKey, u2ScalarLength + 4}, {nu1ScalarNumber, u2ScalarLength + 4}, {nu1OrderPointBase, u2ScalarLength + 4}, {nu1ABase, u2ModLength + 4}, {nu1Workspace, <WorkspaceLength>} or {nu1HashBase, u2ScalarLength + 4} are not in Crypto RAM
- u2ModLength is either: < 12, > 0xffc or not a 32-bit length
- All overlapping between {nu1ModBase, u2ModLength + 4}, {nu1CnsBase, u2ModLength + 8}, {nu1PointABase, 3\*u2ModLength + 12}, {nu1PrivateKey, u2ScalarLength + 4}, {nu1ScalarNumber, u2ScalarLength + 4}, {nu1OrderPointBase, u2ScalarLength + 4}, {nu1ABase, u2ModLength + 4}, {nu1Workspace, <WorkspaceLength>} and {nu1HashBase, u2ScalarLength + 4}

### 43.3.6.11.7 Status Returned Values

**Table 43-86. ZpEcDsaGenerateFast Service Return Codes**

Returned Status	Importance	Meaning
PUKCL_OK	–	The computation passed without problem. The signature is the good one.
PUKCL_WRONG_SELECTNUMBER	Warning	The given value for nu1ScalarNumber is not good to perform this signature generation.

# SAM D5x/E5x Family Data Sheet

## Public Key Cryptography Controller (PUKCC)

### 43.3.6.12 Verifying an ECDSA Signature (Compliant with FIPS186-2)

#### 43.3.6.12.1 Purpose

This service is used to verify an ECDSA signature following the FIPS 186-2. It performs the second step of the Signature Verification.

A hash value (HashVal) must be provided as input, it has to be previously computed from the message to be signed using a secure hash algorithm.

As second significant input, the Signature is provided to be checked. This service checks the signature and fills the status accordingly.

#### 43.3.6.12.2 How to Use the Service

#### 43.3.6.12.3 Description

The operation performed is:

*Verify = EcDsaVerifySignature(Pt<sub>A</sub>, HashVal, Signature, CurveParameters, PublicKey)*

The points used for this operation are represented in different coordinate systems. In this computation, the following parameters need to be provided:

- A the input point is filled with the affine values (X,Y) and Z = 1 (pointed by {nu1PointABase, 3\*u2ModLength + 12})
- Cns the working space for the Fast Modular Constant not initialized (pointed by {nu1CnsBase,u2ScalarLength + 8})
- P the modulus filled (pointed by {nu1ModBase,u2ModLength + 4})
- The workspace not initialized (pointed by {nu1WorkSpace, 8\*u2ModLength + 44})
- The a parameter relative to the elliptic curve (pointed by {nu1ABase,u2ModLength + 4})
- The order of the Point A on the elliptic curve (pointed by {nu1OrderPointBase,u2ScalarLength + 4})
- HashVal the hash value is generated prior and filled (pointed by {nu1HashBase,u2ScalarLength + 4})
- The Public Key point is filled in “mixed” coordinates (X,Y) with the affine values and Z = 1 (pointed by {nu1PointPublicKeyGen, 3\*u2ModLength + 12})
- The input signature (R,S), even if it is not a Point, is represented in memory like a point in affine coordinates (X,Y) (pointed by {nu1PointSignature, 2\*u2ScalarLength + 8})

**Note:** For the ECDSA signature verification be sure to follow the directives given for the RNG on the chip you use (particularly initialization, seeding) and compulsorily start the RNG.

- The operation consists in obtaining a V value with all these input parameters and checking that V equals the provided R. If all is correct and the signature is the good one, the status is set to PUKCL\_OK. If all is correct and the signature is wrong, the status is set to PUKCL\_WRONG\_SIGNATURE. If an error occurs, the status is set to the corresponding error value (see Status Returned Values below).

#### 43.3.6.12.4 Parameters Definition

**Table 43-87. ZpEcDsaVerifyFast Service Parameters**

Parameter	Type	Direction	Location	Data Length	Before Executing the Service	After Executing the Service
nu1ModBase	nu1	I	Crypto RAM	u2ModLength + 4	Base of modulus P	Base of modulus P

# SAM D5x/E5x Family Data Sheet

## Public Key Cryptography Controller (PUKCC)

.....continued

Parameter	Type	Direction	Location	Data Length	Before Executing the Service	After Executing the Service
nu1CnsBase	nu1	I	Crypto RAM	u2ScalarLength + 12	Base of Cns	Base of Cns
u2ModLength	u2	I	–	–	Length of modulus P	Length of modulus P
nu1OrderPointBase	nu1	I	Crypto RAM	u2ScalarLength + 4	Order of the Point A in the elliptic curve	Unchanged
nu1PointSignature	nu1	I	Crypto RAM	2*u2ScalarLength + 8	Signature(r, s)	Corrupted
nu1HashBase (see <b>Note 1</b> )	nu1	I	Crypto RAM	u2ScalarLength + 4	Base of the hash value resulting from the previous SHA	Corrupted
u2ScalarLength	u2	I	–	–	Length of scalar	Length of scalar
nu1PointABase	nu1	I/O	Crypto RAM	3*u2ModLength + 12	Generator point	Corrupted
nu1PointPublicKeyGen	nu1	I/O	Crypto RAM	3*u2ModLength + 12	Public point	Corrupted
nu1ABase	nu1	I	Crypto RAM	u2ModLength + 4	Parameter a of the elliptic curve	Unchanged
nu1Workspace	nu1	I	Crypto RAM	8*u2ModLength + 44	–	Corrupted workspace

**Note:**

- The hash value calculus is defined by the ECDSA norm and depends on the elliptic curve domain parameters. To construct the input parameter, the 4 Most Significant Bytes must be set to zero.

**43.3.6.12.5 Code Example**

```

PUKCL_PARAM PUKCLParam;
PUPUKCL_PARAM pvPUKCLParam = &PUKCLParam;

// ! The Random Number Generator must be initialized and started
// ! following the directives given for the RNG on the chip

PUKCL(u2Option) = 0;

// Depending on the option specified, not all fields should be filled
PUKCL_ZpEcDsaVerify(nulModBase) = <Base of the ram location of P>;
PUKCL_ZpEcDsaVerify(u2ModLength) = <Byte length of P>;
PUKCL_ZpEcDsaVerify(nulCnsBase) = <Base of the ram location of Cns>;
PUKCL_ZpEcDsaVerify(nulPointABase) = <Base of the A point>;
PUKCL_ZpEcDsaVerify(nulPrivateKey) = <Base of the Private Key>;

```



# SAM D5x/E5x Family Data Sheet

## Public Key Cryptography Controller (PUKCC)

```

PUKCL_ZpEcDsaVerify(nulScalarNumber) = <Base of the ScalarNumber>;
PUKCL_ZpEcDsaVerify(nulOrderPointBase) = <Base of the order of A point>;
PUKCL_ZpEcDsaVerify(nulABase) = <Base of the a parameter of the curve>;
PUKCL_ZpEcDsaVerify(nulWorkspace) = <Base of the workspace>;
PUKCL_ZpEcDsaVerify(nulHashBase) = <Base of the SHA resulting hash>;
PUKCL_ZpEcDsaVerify(u2ScalarLength) = < Length of ScalarNumber>;

...

// vPUKCL_Process() is a macro command, which populates the service name
// and then calls the library...
vPUKCL_Process(ZpEcDsaVerifyFast, pvPUKCLParam);
if (PUKCL(u2Status) == PUKCL_OK)
    {
        ...
    }ou
else
    if(PUKCL(u2Status) == PUKCL_WRONG_SIGNATURE)
        {
            ...
        }
    else // Manage the error

```

### 43.3.6.12.6 Constraints

No overlapping between either input and output are allowed. The following conditions must be avoided to ensure that the service works correctly:

- nu1ModBase, nu1CnsBase, nu1PointABase, nu1PointPublicKeyGen, nu1PointSignature, nu1OrderPointBase, nu1ABase, nu1Workspace or nu1HashBase are not aligned on 32-bit boundaries
- {nu1ModBase, u2ModLength + 4}, {nu1CnsBase, u2ModLength + 8}, {nu1PointABase, 3\*u2ModLength+ 12}, {nu1PointPublicKeyGen, 3\*u2ModLength + 12}, {nu1PointSignature, 2\*u2ScalarLength + 8}, {nu1OrderPointBase, u2ScalarLength + 4}, {nu1ABase, u2ModLength + 4}, {nu1Workspace, <WorkspaceLength>} or {nu1HashBase, u2ScalarLength + 4} are not in Crypto RAM
- u2ModLength is either: < 12, > 0xffc or not a 32-bit length
- All overlapping between {nu1ModBase, u2ModLength + 4}, {nu1CnsBase, u2ModLength +8}, {nu1PointABase, 3\*u2ModLength + 12}, {nu1PointPublicKeyGen, 3\*u2ModLength + 12}, {nu1PointSignature, 2\*u2ScalarLength + 8}, {nu1OrderPointBase, u2ScalarLength + 4}, {nu1ABase, u2ModLength + 4}, {nu1Workspace, <WorkspaceLength>} and {nu1HashBase, u2ScalarLength + 4}

### 43.3.6.12.7 Status Returned Values

**Table 43-88. ZpEcDsaVerifyFast Service Return Codes**

Returned Status	Importance	Meaning
PUKCL_OK	–	The computation passed without problem. The signature is the good one.
PUKCL_WRONG_SIGNATURE	Warning	The signature is wrong.

### 43.3.6.13 Quick Verifying an ECDSA Signature (Compliant with FIPS 186-2)

#### 43.3.6.13.1 Purpose

This service is used to verify an ECDSA signature following the FIPS 186-2. It performs the second step of the Signature Verification using Quick Dual Multiplying to perform computation.

A hash value (HashVal) must be provided as input, it has to be previously computed from the message whose signature is verified using a secure hash algorithm.

As second significant input, the Signature is provided to be checked.

# SAM D5x/E5x Family Data Sheet

## Public Key Cryptography Controller (PUKCC)

---

This service checks the signature and fills the status accordingly.

---



**Important:** This service has a quick implementation without additional security.

---

### 43.3.6.13.2 How to Use the Service

#### 43.3.6.13.3 Description

The operation performed is:

*Verify = EcDsaVerifySignature(Pt<sub>A</sub>, HashVal, Signature, CurveParameters, PublicKey)*

The points used for this operation are represented in different coordinate systems.

In this computation, the following parameters need to be provided (such that  $u2MaxLength = \max(u2ModLength, u2ScalarLength)$ ):

- A the input point is filled with the affine values (X,Y) and  $Z = 1$  (pointed by {pu1PointABase,  $(3*(u2ModLength + 4)) * (2^{(WA-2)})$ })
- P the modulus filled and Cns the working space for the Fast Modular Constant not initialized (pointed by {pu1ModBase,  $u2ModLength + u2MaxLength + 16$ })
- The a parameter relative to the elliptic curve filled and workspace not initialized (pointed by {pu1AWorkBase,  $8*u2MaxLength + u2ModLength + 48$ })
- The order of the Point A on the elliptic curve (pointed by {pu1OrderPointBase,  $u2ScalarLength + 4$ })
- HashVal the hash value beforehand generated and filled (pointed by {pu1HashBase,  $u2MaxLength + 4$ })
- The Public Key point is filled in “mixed” coordinates (X,Y) with the affine values and  $Z = 1$  (pointed by {nu1PointPublicKeyGen,  $(3*(u2ModLength + 4)) * (2^{(WB-2)})$ })
- The input signature (R,S), even if it is not a Point, is represented in memory like a point in affine coordinates (X,Y) (pointed by {nu1PointSignature,  $2*u2ScalarLength + 8$ })

The operation consists of obtaining a V value with all input parameters and checks that V equals the provided R. If all is correct and the signature is the good one, the status is set to PUKCL\_OK. If all is correct and the signature is wrong, the status is set to PUKCL\_WRONG\_SIGNATURE. If an error occurs, the status is set to the corresponding error value (see Status Returned Values below).

#### 43.3.6.13.4 Parameters Definition

To place the parameters correctly the maximum of  $u2ModLength$  and  $u2ScalarLength$  must be calculated:  
 $u2MaxLength = \max(u2ModLength, u2ScalarLength)$

WA is the Point A window size and WB is the Point Public Key window size (see Options below for details).



**Important:** Please calculate precisely the length of areas with the formulas and the `max()` service which takes the maximum of two values. Ensure that the pu1 type is a pointer on 4 bytes and contains the full address (see [43.3.3.4 Aligned Significant Length](#) for details).

---

# SAM D5x/E5x Family Data Sheet

## Public Key Cryptography Controller (PUKCC)

**Table 43-89. ZpEcDsaQuickVerify Service Parameters**

Parameter	Type	Direction	Location	Data Length	Before Executing the Service	After Executing the Service
pu1ModCnsBase	pu1	I	Crypto RAM	$u2ModLength + 4 + u2MaxLength + 12$	Base of modulus P	Base of modulus P
u2Option	u2	I	–	–	Option related to the called service (see below)	–
u2ModLength	u2	I	–	–	Length of modulus P	Length of modulus P
pu1OrderPointBase	pu1	I	Crypto RAM	$u2ScalarLength + 4$	Order of the Point A in the elliptic curve	Unchanged
pu1PointSignature	pu1	I	Any RAM	$2 * u2ScalarLength + 8$	Signature(r, s)	Corrupted
pu1HashBase (see <b>Note 1</b> )	pu1	I	Crypto RAM	$u2MaxLength + 4$	Base of the hash value resulting from the previous SHA	Corrupted
u2ScalarLength	u2	I	–	–	Length of scalar	Length of scalar
pu1PointABase	pu1	I/O	Crypto RAM	$(3 * u2ModLength + 12) * (2(WA-2))$	Generator point	Corrupted
pu1PointPublicKeyGen	pu1	I/O	Crypto RAM	$(3 * u2ModLength + 12) * (2(WB-2))$	Public Key point	Corrupted
pu1AWorkBase	pu1	I	Crypto RAM	$(u2ModLength + 4) + (8 * u2MaxLength + 44)$	Parameter a of the elliptic curve and Workspace	Corrupted

**Note:**

1. The hash value calculus is defined by the ECDSA norm and depends on the elliptic curve domain parameters. To construct the input parameter, the 4 Most Significant Bytes must be set to zero.

A suggested parameters placement in Crypto RAM is:

- ModCnsBase
- OrderPointBase
- Signature may be placed here or in Classical RAM
- HashBase

# SAM D5x/E5x Family Data Sheet

## Public Key Cryptography Controller (PUKCC)

- PointABase
- PointPublicKeyGen
- AWorkBase

### 43.3.6.13.5 Options

The options are set by the u2Options input parameter, which is composed of:

- the mandatory windows sizes WA (window for Point A) and WB (window for Point Public Key)
- the indication of the presence of the Point Signature in system RAM



**Important:** Please check precisely if the Point Signature is in Crypto RAM. If this is the case the PUKCL\_ZPECCMUL\_SCAL\_IN\_CLASSIC\_RAM must not be used.

The u2Options number is calculated by an “Inclusive OR” of the options. Some Examples in C language are:

- ```
// Point Signature in system RAM
// The Point A window size is 3
// The Point Public Key window size is 4
PUKCL(u2Options) = PUKCL_ZPECCMUL_SCAL_IN_CLASSIC_RAM |
PUKCL_ZPECCMUL_WINSIZE_A_VAL_TO_OPT(3) |
PUKCL_ZPECCMUL_WINSIZE_B_VAL_TO_OPT(4);
```
- ```
// Point Signature in the Cryptographic RAM
// The Point A window size is 2
// The Point Public Key window size is 5
PUKCL(u2Options) = PUKCL_ZPECCMUL_WINSIZE_A_VAL_TO_OPT(2) |
PUKCL_ZPECCMUL_WINSIZE_B_VAL_TO_OPT(5);
```

For this service, many window sizes are possible. The window sizes in bits are those of the windowing method used for the scalar multiplying.

The choice of the window sizes is a balance between the size of the parameters and the computation time:

- Increasing the window size increases the precomputation table size.
- Increasing the window size to the optimum reduces the computation time.

The following table details the estimated windows WA and WB optimum and possible for some curves.

**Table 43-90. ZpEcDsaQuickVerify Service Estimated WA and WB Window Size**

Curve Size (bits)	Optimum Window size	Possible Window Sizes (WA, WB) or (WB, WA)
192	5	5, 5
256	5	5, 5
384	6	5, 5
521	6	4, 5

# SAM D5x/E5x Family Data Sheet

## Public Key Cryptography Controller (PUKCC)

The following table details the size of the point and the precomputation table, depending on the chosen window size option.

**Table 43-91. ZpEcDsaQuickVerify Service Window Size and Precomputation Table Size Options**

Option Specified	Point and Precomputation Table Size
PUKCL_ZPECCMUL_WINSIZE_A_VAL_TO_OPT(WA) WA in [2, 15]	$(3*(u2ModLength + 4)) * (2^{(WA-2)})$
PUKCL_ZPECCMUL_WINSIZE_B_VAL_TO_OPT(WB) WB in [2, 15]	$(3*(u2ModLength + 4)) * (2^{(WB-2)})$

The Point Signature can be located in PUKCC RAM or in system RAM. If the Point Signature is entirely in system RAM with no part in PUKCC RAM this can be signaled by using the option PUKCL\_ZPECCMUL\_SCAL\_IN\_CLASSIC\_RAM. In all other cases this option must not be used.

The following table describes this option.

**Table 43-92. ZpEcDsaQuickVerify Service Point Signature in Classical RAM Option**

Option	Purpose
PUKCL_ZPECCMUL_SCAL_IN_CLASSIC_RAM	The Point Signature can be located in Crypto RAM or in system RAM. If the Point Signature is entirely in system RAM with no part in PUKCC RAM this can be signaled by using this option. In all other cases this option must not be used.

### 43.3.6.13.6 Code Example

```

PUKCL_PARAM PUKCLParam;
PvPUKCL_PARAM pvPUKCLParam = &PUKCLParam;
PUKCL(u2Option) = <Point Signature location and windows sizes>;
PUKCL_ZpEcDsaQuickVerify(pulModCnsBase) = <Base of the ram location of P and Cns>;
PUKCL_ZpEcDsaQuickVerify(u2ModLength) = <Byte length of P>;
PUKCL_ZpEcDsaQuickVerify(pulPointABase) = <Base of the ram location of the A point>;
PUKCL_ZpEcDsaQuickVerify(pulPointPublicKeyGen) = <Base of the Public Key>;
PUKCL_ZpEcDsaQuickVerify(pulPointSignature) = <Base of the Signature (r, s)>;
PUKCL_ZpEcDsaQuickVerify(pulOrderPointBase) = <Base of the order of the A point>;
PUKCL_ZpEcDsaQuickVerify(pulAWorkBase) = <Base of the ram location of the parameter A of the
elliptic curve and workspace>;
PUKCL_ZpEcDsaQuickVerify(pulHashBase) = <Base of the SHA resulting hash>;
PUKCL_ZpEcDsaQuickVerify(u2ScalarLength) = <Byte length of R and S in Point Signature>;
...
// vPUKCL_Process() is a macro command, which populates the service name
// and then calls the library...
vPUKCL_Process(ZpEcDsaQuickVerify, pvPUKCLParam);
if (PUKCL(u2Status) == PUKCL_OK)
{
    ...
}
else
    if ( PUKCL(u2Status) = PUKCL_WRONG_SIGNATURE )
    {
        ...
    }
    else // Manage the error

```

### 43.3.6.13.7 Constraints

No overlapping between either input and output are allowed. The following conditions must be avoided to ensure that the service works correctly:

# SAM D5x/E5x Family Data Sheet

## Public Key Cryptography Controller (PUKCC)

- pu1ModCnsBase, pu1PointABase, pu1PointPublicKeyGen, pu1PointSignature, pu1OrderPointBase, pu1AWorkBase or pu1HashBase are not aligned on 32-bit boundaries
- {pu1ModCnsBase, u2ModLength + 4 + u2MaxLength + 12}, {pu1PointABase, (3 \* u2ModLength + 12) \* (2<sup>(WA-2)</sup>)}, {pu1PointPublicKeyGen, (3 \* u2ModLength + 12) \* (2<sup>(WPub-2)</sup>)}, {pu1OrderPointBase, u2ScalarLength + 4}, {nu1ABase, u2ModLength + 4}, {pu1AWorkBase, (u2ModLength + 4) + (8 \* u2MaxLength + 44)} or {nu1HashBase, u2ScalarLength + 4} are not in Crypto RAM
- u2ModLength is either: < 12, > 0xffc or not a 32-bit length
- All overlapping between {pu1ModCnsBase, u2ModLength + 4 + u2MaxLength + 12}, {pu1PointABase, (3 \* u2ModLength + 12) \* (2<sup>(WA-2)</sup>)}, {pu1PointPublicKeyGen, (3 \* u2ModLength + 12) \* (2<sup>(WPub-2)</sup>)}, {pu1OrderPointBase, u2ScalarLength + 4}, {pu1PointSignature, 2 \* u2ScalarLength + 8}, {nu1ABase, u2ModLength + 4}, {pu1AWorkBase, (u2ModLength + 4) + (8 \* u2MaxLength + 44)} and {nu1HashBase, u2ScalarLength + 4}

### 43.3.6.13.8 Status Returned Values

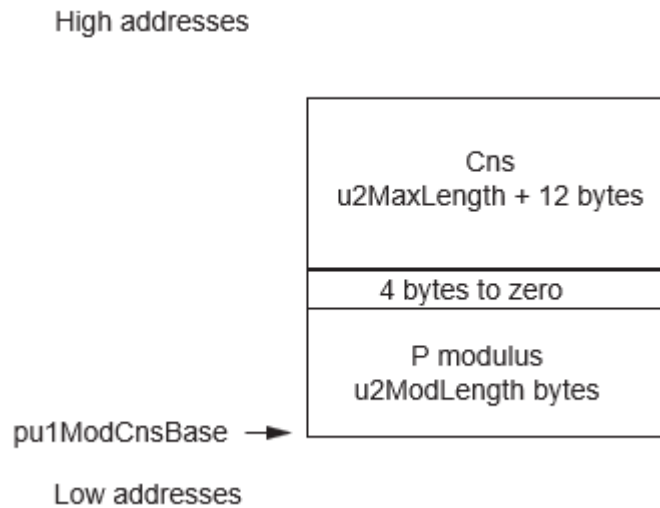
**Table 43-93. ZpEcDsaQuickVerify Service Return Codes**

Returned Status	Importance	Meaning
PUKCL_OK	–	The computation passed without problem. The signature is the good one.
PUKCL_WRONG_SIGNATURE	Warning	The signature is wrong.

### 43.3.6.13.9 Parameter Placement

The parameters' placement is described in detail in the following figures.

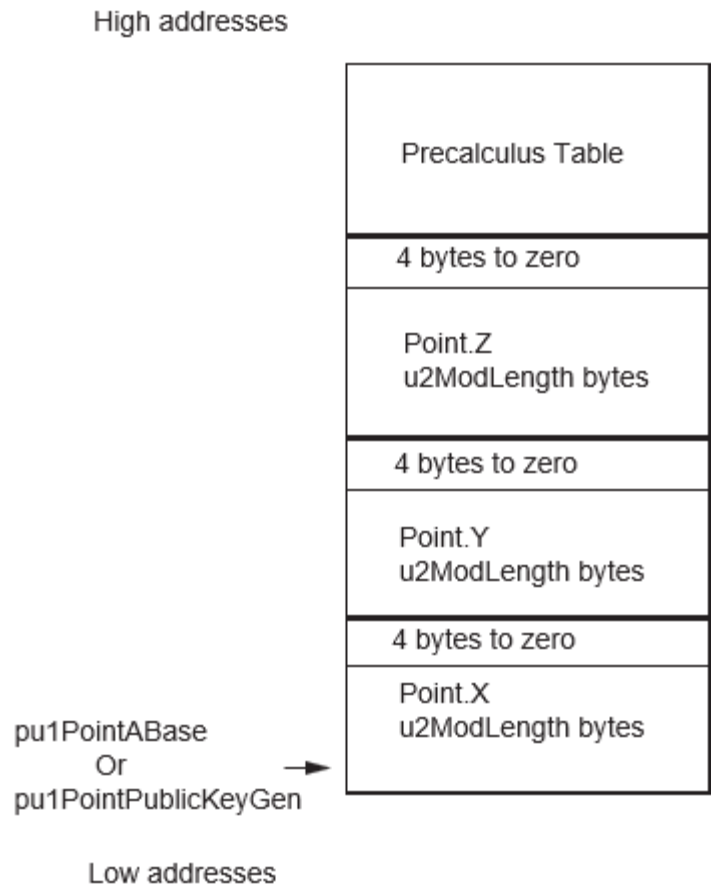
**Figure 43-11. Modulus P and Cns{pu1ModCnsBase, u2ModLength + 4 + u2MaxLength + 12}**



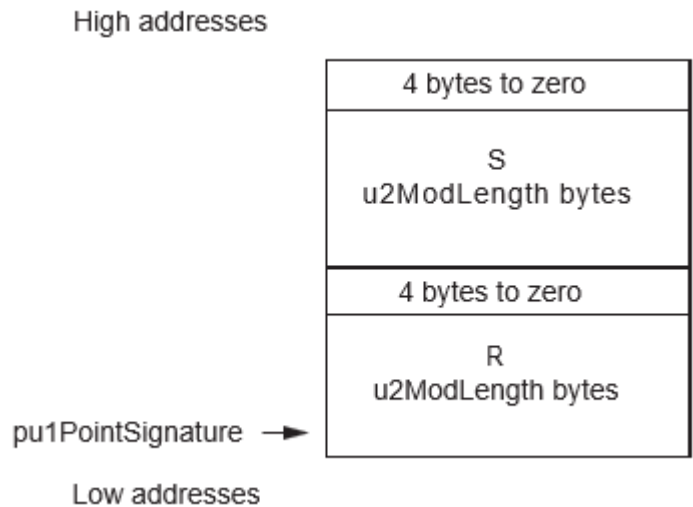
# SAM D5x/E5x Family Data Sheet

## Public Key Cryptography Controller (PUKCC)

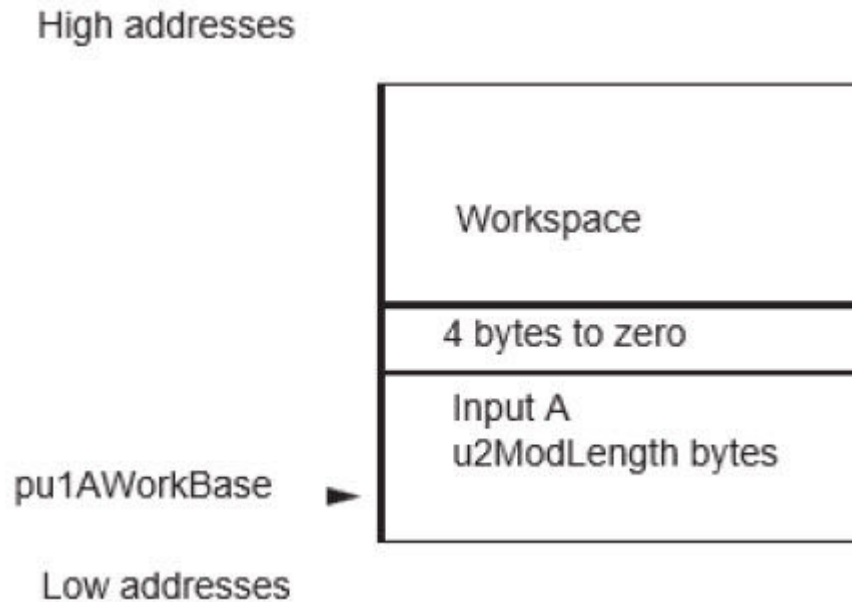
**Figure 43-12. Points A {pu1PointABase,  $(3 \cdot (u2ModLength + 4)) \cdot (2^{(WA-2)})$ } and Public Key Gen {pu1PointPublicKeyGen,  $(3 \cdot (u2ModLength + 4)) \cdot (2^{(WB-2)})$ }**



**Figure 43-13. PointSignature {pu1PointSignature,  $2 \cdot u2ScalarLength + 8$ }**



**Figure 43-14. The a parameter and Workspace {pu1AWorkBase, 9\*u2ModLength + 48}**



### 43.3.7 Elliptic Curves Over GF(2<sup>n</sup>) Services

This section provides a complete description of the currently available elliptic curve over Polynomials in GF(2<sup>n</sup>) services.

These services process Polynomials in GF(2<sup>n</sup>) only.

The offered services cover the basic operations over elliptic curves such as:

- Adding two points over a curve
- Doubling a point over a curve
- Multiplying a point by an integral constant
- Converting a point's projective coordinates (resulting from a doubling or an addition) to the affine coordinates, and oppositely converting a point's affine coordinates to the projective coordinates.
- Testing the point presence on the curve.

Additionally, some higher level services covering the needs for signature generation and verification are offered:

- Generating an ECDSA signature (compliant with FIPS186-2)
- Verifying an ECDSA signature (compliant with FIPS 186-2) The supported curves use the following curve equation in GF(2<sup>n</sup>):

$$Y^2 + XY = X^3 + aX + b$$

#### 43.3.7.1 Parameters Format

##### 43.3.7.1.1 Polynomials in GF(2<sup>n</sup>)

Polynomials in GF(2<sup>n</sup>) are binary polynomials reduced modulo the polynomial P[X]. This polynomial is called the modulus and may be abbreviated to P in this document. The storage of these polynomials in memory area is described in [43.3.3.4 Aligned Significant Length](#).

For notation simplicity the comparison signs "<" or ">" may be used for polynomials, this is to be interpreted as a comparison between the degree of the polynomials.



# SAM D5x/E5x Family Data Sheet

## Public Key Cryptography Controller (PUKCC)

In  $GF(2^n)$  fully reduced polynomials are of degree strictly lower than  $\text{degree}(P[X])$ . In many cases the polynomials used in this library are only partially reduced and so have a degree higher or equal than  $\text{degree}(P[X])$ , but this degree is maintained strictly lower than  $(\text{degree}(P[X]) + 15)$ .

### 43.3.7.1.2 Coordinates System

In this implementation, several choices have been made related to the coordinate systems managed by the elliptic curve primitives.

There are two systems currently managed by the library:

- Affine Coordinates System where each curve point has two coordinates (X,Y)
- Projective Coordinates System where each point is represented with three coordinates (X,Y,Z)

Converting from the affine coordinates system to a projective coordinates system and is performed by extending its representation having  $Z = 1$ :

$$(X, Y) \Rightarrow (X, Y, Z = 1)$$

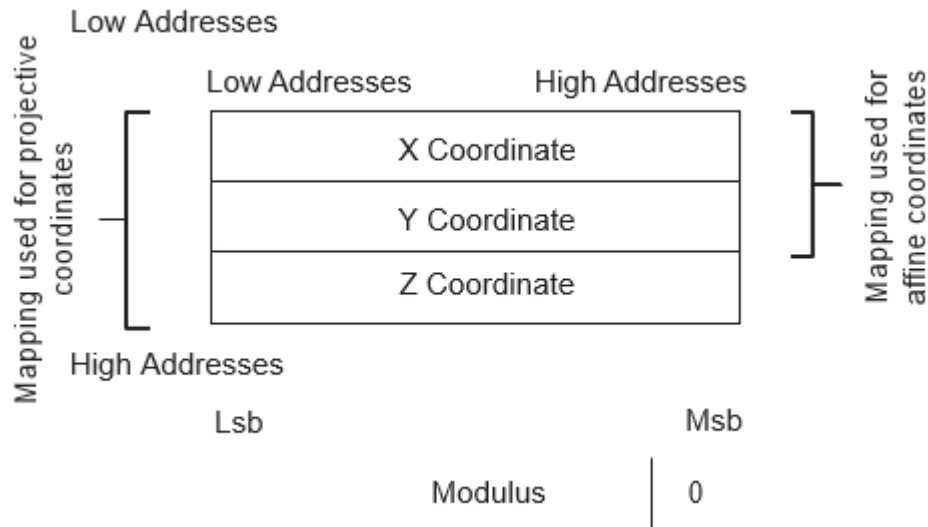
Converting from a projective coordinate to an affine one is a service offered by the library. The formula to perform this conversion is:

$$(X, Y, Z) \Rightarrow (X \Rightarrow Z, Y/Z^2)$$

### 43.3.7.1.3 Points Representation in Memory

Depending on the representation (Projective or Affine), points are represented in memory as shown in the following figure.

**Figure 43-15. Point Representation in Memory**



In this figure, the modulus is represented as a reference, and to show that coordinates are always to be provided on the length of the modulus plus one 32-bit word.

Different types of representations are listed here:

$$\text{Affine representation: } Pt = \begin{bmatrix} X_{Affine} < P \times X^{15} \\ Y_{Affine} < P \times X^{15} \end{bmatrix}$$

$$\text{Projective representation: } Pt = \begin{bmatrix} X_{\text{Projective}} < P \times X^{15} \\ Y_{\text{Projective}} < P \times X^{15} \\ Z_{\text{Projective}} < P \times X^{15} \end{bmatrix}$$

**Note:**

1. The minimum value for u2ModLength is 12 bytes. Therefore, the significant length of the modulus must be at least three 32-bit words.
2. In some cases the point can be the infinite point. In this case it is represented with its Z coordinates equal or congruent to zero.

#### 43.3.7.1.4 Modulus and Modular Constant Parameters

In most of the services the following parameters must be provided:

- P the Modulus (often pointed by {nu1ModBase,u2ModLength + 4}): This parameter contains the Modulus Polynomial P[X] defining the Galois Field used in points coordinates computations. The Modulus must be u2ModLength bytes long, while having a supplemental zeroed 32-bit word on the MSB side.  
**Note:** Most of the Elliptic Curve computations are reduced modulo P. In many functions the reductions are made with the Fast Reduction.
- Cns the Modular Constant (often pointed by {nu1CnsBase,u2ModLength + 12}): This parameter contains the Modular Constant associated to the Modulus.



**Important:** The Modular Constant must be calculated before using the GF(2<sup>n</sup>) Elliptic Curves functions by a call to the Setup for Modular Reductions with the GF(2<sup>n</sup>) option (see [43.3.5.1 Modular Reduction](#)).

#### 43.3.7.1.5 Curve Parameters in Memory

Some services need one or both of the Elliptic Curve Equation Parameters a and b. In this case these values are organized in memory as follows:

- The a Parameter relative to the Elliptic Curve Equation (often pointed by {nu1ABase,u2ModLength +4}). The a Parameter is written in a classical way in memory. It is u2ModLength bytes long and has a supplemental zeroed 32-bit word on the MSB side.
- The a and b Parameters relative to the Elliptic Curve Equation (often pointed by {nu1ABase, 2\*u2ModLength + 8}):
  - The a Parameter is written in memory on u2ModLength bytes long, with a supplemental zeroed 32-bit word on the MSB side.
  - The b Parameter is written in memory after the a Parameter at an offset of (u2ModLength + 4) bytes. It is written in memory on u2ModLength bytes long, with a supplemental zeroed 32-bit word on the MSB side.

#### 43.3.7.2 Point Addition

##### 43.3.7.2.1 Purpose

This service is used to perform a point addition, based on a given elliptic curve over GF(2<sup>n</sup>).

Please note that this service is not intended to add the same point twice. In this particular case, use the doubling service (see [43.3.7.3 Point Doubling](#)).

# SAM D5x/E5x Family Data Sheet

## Public Key Cryptography Controller (PUKCC)

### 43.3.7.2.2 How to Use the Service

#### 43.3.7.2.3 Description

The operation performed is:

$$Pt_C = Pt_A + Pt_B$$

In this computation, the following parameters need to be provided:

- Point A the input point is filled in projective coordinates (X,Y,Z) (pointed by {nu1PointABase, 3\*u2ModLength + 12}). This point can be the Infinite Point.
- Point B the input point is filled in projective coordinates (X,Y,Z) (pointed by {nu1PointBBase, 3\*u2ModLength + 12}). This point can be the Infinite Point.
- Cns the Fast Modular Constant filled (pointed by {nu1CnsBase,u2ModLength + 12})
- P the modulus filled (pointed by {nu1ModBase,u2ModLength + 4})
- The a parameter relative to the elliptic curve equation (pointed by {nu1ABase,u2ModLength + 4})
- The workspace not initialized (pointed by {nu1WorkSpace, 7\*u2ModLength + 40})

The resulting C point is represented in projective coordinates (X,Y,Z) and is stored at the same place than the input point A. This Point can be the Infinite Point.

The services for this operation are:

- Service GF2NEccAddFast: The fast mode is used, the fast modular reduction is used in the computations.



**Important:** Before using this service, ensure that the constant Cns has been calculated with the setup of the Modular Reductions service.

### 43.3.7.2.4 Parameters Definition

**Table 43-94. GF2NEccAddFast Service Parameters**

Parameter	Type	Direction	Location	Data Length	Before Executing the Service	After Executing the Service
nu1ModBase	nu1	I	Crypto RAM	u2ModLength + 4	Base of Modulus P	Base of Modulus P
nu1CnsBase	nu1	I	Crypto RAM	u2ModLength + 12	Base of Cns	Base of Cns
u2ModLength	u2	I	–	–	Length of modulo	Length of modulo
nu1PointABase	nu1	I/O	Crypto RAM	3*u2ModLength + 12	Input point A (projective coordinates)	Resulting point C (projective coordinates)
nu1PointBBase	nu1	I	Crypto RAM	3*u2ModLength + 12	Input point B (projective coordinates)	Input point B

# SAM D5x/E5x Family Data Sheet

## Public Key Cryptography Controller (PUKCC)

.....continued

Parameter	Type	Direction	Location	Data Length	Before Executing the Service	After Executing the Service
nu1ABBase	nu1	I	Crypto RAM	u2ModLength + 4	Parameter a of the elliptic curve	Unchanged
nu1Workspace	nu1	I	Crypto RAM	7*u2ModLength + 40	–	Corrupted workspace

### 43.3.7.2.5 Code Example

```

PUKCL_PARAM PUKCLParam;
PPUKCL_PARAM pvPUKCLParam = &PUKCLParam;
//Depending on the function the Random Number Generator
//must be initialized and started
//following the directives given for the RNG on the chip
PUKCL(u2Option) = 0;
PUKCL_GF2NEccAdd(nu1ModBase) = <Base of the ram location of P>;
PUKCL_GF2NEccAdd(nu1CnsBase) = <Base of the ram location of Cns>;
PUKCL_GF2NEccAdd(u2ModLength) = <Byte length of P>;
PUKCL_GF2NEccAdd(nu1PointABase) = <Base of the ram location of the A point>;
PUKCL_GF2NEccAdd(nu1PointBBase) = <Base of the ram location of the B point>;
PUKCL_GF2NEccAdd(nu1ABBase) = <Base of the ram location of the a Parameter>;
PUKCL_GF2NEccAdd(nu1Workspace) = <Base of the ram location of the workspace>;
. . .
// vPUKCL_Process() is a macro command, which populates the service name
// and then calls the library...
vPUKCL_Process(GF2NEccAddFast, pvPUKCLParam);
if (PUKCL(u2Status) == PUKCL_OK)
{
. . .
}
else // Manage the error

```

### 43.3.7.2.6 Constraints

No overlapping between either input and output are allowed The following conditions must be avoided to ensure the service works correctly:

- nu1ModBase, nu1CnsBase, nu1PointABase, nu1PointBBase, nu1ABBase, nu1Workspace are not aligned on 32-bit boundaries
- {nu1ModBase, u2ModLength + 4}, {nu1CnsBase, u2ModLength + 8}, {nu1PointABase, 3\*u2ModLength+ 12}, {nu1PointBBase, 3\*u2ModLength + 12}, {nu1ABBase, u2ModLength + 4}, {nu1Workspace, <WorkspaceLength>} are not in Crypto RAM
- u2ModLength is either: < 12, > 0xffc or not a 32-bit length
- All overlapping between {nu1ModBase, u2ModLength + 4}, {nu1CnsBase, u2ModLength +8}, {nu1PointABase, 3\*u2ModLength + 12}, {nu1PointBBase, 3\*u2ModLength + 12}, {nu1ABBase, u2ModLength + 4} and {nu1Workspace, 5\*u2ModLength + 32}

### 43.3.7.2.7 Status Returned Values

**Table 43-95. GF2NEccAddFast Service Return Codes**

Returned Status	Importance	Meaning
PUKCL_OK	–	The computation passed without errors.

### 43.3.7.3 Point Doubling

#### 43.3.7.3.1 Purpose

This service is used to perform a Point Doubling, based on a given elliptic curve over GF(2<sup>n</sup>).

# SAM D5x/E5x Family Data Sheet

## Public Key Cryptography Controller (PUKCC)

### 43.3.7.3.2 How to Use the Service

#### 43.3.7.3.3 Description

The operation performed is:

$$Pt_C = 2 \times Pt_A$$

In this computation, the following parameters need to be provided:

- A the input point is filled in projective coordinates (X,Y,Z) (pointed by {nu1PointABase, 3\*u2ModLength + 12}). This point can be the Infinite Point.
- Cns the Fast Modular Constant filled (pointed by {nu1CnsBase,u2ModLength +8})
- P the modulus filled (pointed by {nu1ModBase,u2ModLength +4})
- The workspace not initialized (pointed by {nu1WorkSpace, 4\*u2ModLength +28})
- The a and b Parameters relative to the Elliptic Curve Equation (pointed by {nu1ABBase, 2\*u2ModLength+ 8})
- The resulting C point is represented in projective coordinates (X,Y,Z) and is stored at the very same place than the input point A. This point can be the Infinite Point.

The service name for this operation is `GF2NEccDb1Fast`. This service uses Fast mode and Fast Modular Reduction for computation.



**Important:** Before using this service, ensure that the constant Cns has been calculated with the setup of the Fast Modular Reductions service.

#### 43.3.7.3.4 Parameters Definition

**Table 43-96. GF2NEccDb1Fast Service Parameters**

Parameter	Type	Direction	Location	Data Length	Before Executing the Service	After Executing the Service
nu1ModBase	nu1	I	Crypto RAM	u2ModLength + 4	Base of modulus P	Base of modulus P
nu1CnsBase	nu1	I	Crypto RAM	u2ModLength + 12	Base of Cns	Base of Cns
u2ModLength	u2	I	–	–	Length of modulus P	Length of modulus P
nu1ABBase	u2	I	Crypto RAM	2*u2ModLength + 8	Parameters a and b of the elliptic curve	Parameter a and b of the elliptic curve
nu1PointABase	nu1	I/O	Crypto RAM	3*u2ModLength + 12	Input point A (projective coordinates)	Resulting point C (projective coordinates)
nu1Workspace	nu1	I	Crypto RAM	4*u2ModLength + 28	–	Corrupted workspace

# SAM D5x/E5x Family Data Sheet

## Public Key Cryptography Controller (PUKCC)

### 43.3.7.3.5 Code Example

```

PUKCL_PARAM PUKCLParam;
P_PUKCL_PARAM pvPUKCLParam = &PUKCLParam;

PUKCL (u2Option) = 0;

PUKCL _GF2NEccDb1(nu1ModBase) = <Base of the ram location of P>;
PUKCL _GF2NEccDb1(u2ModLength) = <Byte length of P>;
PUKCL _GF2NEccDb1(nu1CnsBase) = <Base of the ram location of Cns>;
PUKCL _GF2NEccDb1(nu1PointABase) = <Base of the ram location of the A point>;
PUKCL _GF2NEccDb1(nu1ABBase) = <Base of the a and b parameters of the elliptic curve>;
PUKCL _GF2NEccDb1(nu1Workspace) = <Base of the ram location of the workspace>;
...

// vPUKCL_Process() is a macro command, which populates the service name
// and then calls the library...
vPUKCL_Process(GF2NEccDb1Fast,&PUKCLParam);
if (PUKCL (u2Status) == PUKCL_OK)
{
    ...
}
else // Manage the error

```

### 43.3.7.3.6 Constraints

No overlapping between either input and output are allowed. The following conditions must be avoided to ensure the service works correctly:

- nu1ModBase, nu1CnsBase, nu1PointABase, nu1ABBase, nu1Workspace are not aligned on 32-bit boundaries
- {nu1ModBase, u2ModLength + 4}, {nu1CnsBase, u2ModLength + 8}, {nu1PointABase, 3\*u2ModLength+ 12}, {nu1ABBase, 2\*u2ModLength + 8}, {nu1Workspace, <WorkspaceLength>} are not in Crypto RAM
- u2ModLength is either: < 12, > 0xffc or not a 32-bit length
- All overlapping between {nu1ModBase, u2ModLength + 4}, {nu1CnsBase, u2ModLength + 8}, {nu1PointABase, 3\*u2ModLength + 12}, {nu1ABBase, u2ModLength + 4} and {nu1Workspace, 4\*u2ModLength + 28}

### 43.3.7.3.7 Status Returned Values

**Table 43-97. GF2NEccDb1Fast Service Return Codes**

Returned Status	Importance	Meaning
PUKCL_OK	–	The computation passed without problem.

### 43.3.7.4 Scalar Point Multiply

#### 43.3.7.4.1 Purpose

This service is used to multiply a point by an integral constant K on a given elliptic curve over GF(2<sup>n</sup>).

#### 43.3.7.4.2 How to Use the Service

#### 43.3.7.4.3 Description

The operation performed is:

$$Pt_C = K \times Pt_A$$

In this computation, the following parameters need to be provided:

- A the input point is filled in projective coordinates (X,Y,Z) (pointed by {nu1PointABase, 3\*u2ModLength + 12}). This point can be the Infinite Point.
- Cns the Fast Modular Constant filled (pointed by {nu1CnsBase,u2ModLength + 8})

# SAM D5x/E5x Family Data Sheet

## Public Key Cryptography Controller (PUKCC)

- P the modulus filled (pointed by {nu1ModBase,u2ModLength + 4})
- The workspace not initialized (pointed by {nu1WorkSpace, 8\*u2ModLength + 44})
- The a and b parameters relative to the elliptic curve (pointed by {nu1ABBase,2\*u2ModLength + 8})
- K the scalar number (pointed by {nu1ScalarNumber,u2ScalarLength + 4})

The resulting C point is represented in projective coordinates (X,Y,Z) and is stored at the very same place than the input point A. This point can be the Infinite Point.

The service name for this operation is `GF2NEccMulFast`. This service uses Fast mode and Fast Modular Reduction for computation.



**Important:** Before using this service, ensure that the constant Cns has been calculated with the setup of the Fast Modular Reductions service.

### 43.3.7.4.4 Parameters Definition

**Table 43-98. GF2NEccMulFast Service Parameters**

Parameter	Type	Direction	Location	Data Length	Before Executing the Service	After Executing the Service
nu1ModBase	nu1	I	Crypto RAM	u2ModLength + 4	Base of modulus P	Base of modulus P
nu1CnsBase	nu1	I	Crypto RAM	u2ModLength + 12	Base of Cns	Base of Cns
u2ModLength	u2	I	–	–	Length of modulus P	Length of modulus P
nu1KBase	nu1	I	Crypto RAM	u2KLength	Scalar number used to multiply the point A	Unchanged
u2KLength	u2	I	–	–	Length of scalar K	Length of scalar K
nu1PointBase	nu1	I/O	Crypto RAM	3*u2ModLength + 12	Input point A (projective coordinates)	Resulting point C (projective coordinates)
nu1ABase	nu1	I	Crypto RAM	2*u2ModLength + 8	Parameters a and b of the elliptic curve	Unchanged
nu1Workspace	nu1	I	Crypto RAM	8*u2ModLength + 44	–	Corrupted workspace

### 43.3.7.4.5 Code Example

```

PUKCL_PARAM PUKCLParam;
PPUKCL_PARAM pvPUKCLParam = &PUKCLParam;

PUKCL (u2Option) = 0;

```

# SAM D5x/E5x Family Data Sheet

## Public Key Cryptography Controller (PUKCC)

```

PUKCL _GF2NEccMul(nu1ModBase) = <Base of the ram location of P>;
PUKCL _GF2NEccMul(u2ModLength) = <Byte length of P>;
PUKCL _GF2NEccMul(nu1CnsBase) = <Base of the ram location of Cns>;
PUKCL _GF2NEccMul(nu1PointBase) = <Base of the ram location of the A point>;
PUKCL _GF2NEccMul(nu1ABase) = <Base of the ram location of the parameters a and b of the
elliptic
curve>;
PUKCL _GF2NEccMul(nu1KBase) = <Base of the ram location of the scalar number>;
PUKCL _GF2NEccMul(nu1Workspace) = <Base of the ram location of the workspace>;
PUKCL _GF2NEccMul(u2KLength) = <Length of the ram location of the scalar number>;

...

// vPUKCL_Process() is a macro command, which populates the service name
// and then calls the library...
vPUKCL_Process(GF2NEccMulFast, &PUKCLParam);
if (PUKCL (u2Status) == PUKCL_OK)
{
    ...
}
else // Manage the error

```

### 43.3.7.4.6 Constraints

No overlapping between either input and output are allowed. The following conditions must be avoided to ensure the service works correctly:

- nu1ModBase, nu1CnsBase, nu1PointBase, nu1ABase, nu1KBase, nu1Workspace are not aligned on 32-bit boundaries
- {nu1ModBase, u2ModLength + 4}, {nu1CnsBase, u2ModLength + 8}, {nu1PointBase, 3\*u2ModLength+ 12}, {nu1ABase, 2\*u2ModLength + 8}, {nu1KBase, u2KLength} or {nu1Workspace, 8\*u2ModLength + 44} are not in Crypto RAM
- u2ModLength is either: < 12, > 0xffc or not a 32-bit length
- All overlapping between {nu1ModBase, u2ModLength + 4}, {nu1CnsBase, u2ModLength +8}, {nu1PointBase, 3\*u2ModLength + 12}, {nu1ABase, 2\*u2ModLength + 8}, {nu1KBase, u2KLength} and {nu1Workspace, 8\*u2ModLength + 44}

### 43.3.7.4.7 Status Returned Values

**Table 43-99. GF2NEccMulFast Service Return Codes**

Returned Status	Importance	Meaning
PUKCL_OK	–	The computation passed without problem.

### 43.3.7.5 Projective to Affine Coordinates Conversion

#### 43.3.7.5.1 Purpose

This service is used to perform a point coordinates conversion from a projective representation to an affine.

#### 43.3.7.5.2 How to Use the Service

#### 43.3.7.5.3 Description

The operation performed is:

$$Pt_X \text{ Affine coordinate} = \left[ \frac{Pt_X \text{ Projective coordinate}}{(Pt_Z \text{ Projective coordinate})} \right]$$

$$Pt_Y \text{ Affine coordinate} = \left[ \frac{Pt_Y \text{ Projective coordinate}}{(Pt_Z \text{ Projective coordinate})^2} \right]$$

In this computation, the following parameters need to be provided:



# SAM D5x/E5x Family Data Sheet

## Public Key Cryptography Controller (PUKCC)

- A the input point is filled in projective coordinates (X,Y,Z) or affine coordinates for X and Y, and setting Z to 1 (pointed by {nu1PointABase, 3\*u2ModLength + 12}). The Point A can be the point at infinity. In this case, the u2Status returned is PUKCL\_POINT\_AT\_INFINITY.
- Cns the Modular Constant filled (pointed by {nu1CnsBase, u2ModLength + 8})
- P the modulus filled (pointed by {nu1ModBase, u2ModLength + 4})
- The workspace not initialized (pointed by {nu1Workspace, 4\*u2ModLength + 48})

The result is the point A with its (X,Y) coordinates converted to affine, and the Z coordinate set to 1.

The service name for this operation is GF2NEcConvProjToAffine.



**Important:** Before using this service, ensure that the constant Cns has been calculated with the setup of the Fast Modular Reductions service.

### 43.3.7.5.4 Parameters Definition

**Table 43-100. GF2NEcConvProjToAffine Service Parameters**

Parameter	Type	Direction	Location	Data Length	Before Executing the Service	After Executing the Service
nu1ModBase	nu1	I	Crypto RAM	u2ModLength + 4	Base of modulus P	Base of modulus P
nu1CnsBase	nu1	I	Crypto RAM	u2ModLength + 12	Base of Cns	Base of Cns
u2ModLength	u2	I	–	–	Length of modulus P	Length of modulus P
nu1PointABase	nu1	I	Crypto RAM	3*u2ModLength + 12	Input point A	Resulting point A in affine coordinates
nu1Workspace	nu1	I	Crypto RAM	4*u2ModLength + 48	–	Workspace

### 43.3.7.5.5 Code Example

```

PUKCL_PARAM PUKCLParam;
PUPUKCL_PARAM pvPUKCLParam = &PUKCLParam;

// ! The Random Number Generator must be initialized and started
// ! following the directives given for the RNG on the chip

PUKCL (u2Option) = 0;

PUKCL _GF2NEcConvProjToAffine(nulModBase) = <Base of the ram location of P>;
PUKCL _GF2NEcConvProjToAffine(u2ModLength) = <Byte length of P>;
PUKCL _GF2NEcConvProjToAffine(nulCnsBase) = <Base of the ram location of Cns>;
PUKCL _GF2NEcConvProjToAffine(nulPointABase) = <Base of the ram location of the A point>;
PUKCL _GF2NEcConvProjToAffine(nulWorkspace) = <Base of the ram location of the workspace>;
...

// vPUKCL_Process() is a macro command, which populates the service name
// and then calls the library...
vPUKCL_Process(GF2NEcConvProjToAffine, &PUKCLParam);
if (PUKCL (u2Status) == PUKCL_OK)
{

```

```

        ...
    }
else // Manage the error

```

### 43.3.7.5.6 Constraints

No overlapping between either input and output are allowed. The following conditions must be avoided to ensure the service works correctly:

- nu1ModBase, nu1CnsBase, nu1PointABase, nu1Workspace are not aligned on 32-bit boundaries
- {nu1ModBase, u2ModLength + 4}, {nu1CnsBase, u2ModLength + 8}, {nu1PointABase, 3\*u2ModLength + 12}, {nu1Workspace, <WorkspaceLength>} are not in Crypto RAM
- u2ModLength is either: < 12, > 0xffc or not a 32-bit length
- All overlapping between {nu1ModBase, u2ModLength + 4}, {nu1CnsBase, u2ModLength + 8}, {nu1PointABase, 3\*u2ModLength + 12} and {nu1Workspace, 4\*u2ModLength + 48}

### 43.3.7.5.7 Status Returned Values

**Table 43-101. GF2NEcConvProjToAffine Service Return Codes**

Returned Status	Importance	Meaning
PUKCL_OK	–	The computation passed without problem.
PUKCL_POINT_AT_INFINITY	Warning	The input point has its Z equal to zero, so it is a representation of the infinite point.

### 43.3.7.6 Affine to Projective Coordinates Conversion

#### 43.3.7.6.1 Purpose

This service is used to perform a point coordinates conversion from an affine point representation to projective.

#### 43.3.7.6.2 How to Use the Service

#### 43.3.7.6.3 Description

The operation performed is:

$$\text{affine}(X_a, Y_a) \rightarrow \text{projective}(X_p, Y_p, Z_p)$$

In this computation, the following parameters need to be provided:

- A the input point is filled in affine coordinates for X and Y, and setting Z to 1 (pointed by {nu1PointABase, 3\*u2ModLength + 4}).
- Cns the Fast Modular Constant filled (pointed by {nu1CnsBase, u2ModLength + 8})
- P the modulus filled (pointed by {nu1ModBase, u2ModLength + 4})
- The workspace not initialized (pointed by {nu1WorkSpace, 2\*u2ModLength + 16}) The result is the point A with its (X,Y,Z) projective coordinates.

The service name for this operation is GF2NEcConvAffineToProjective.



**Important:** Before using this service, ensure that the constant Cns has been calculated with the setup of the Fast Modular Reductions service.

# SAM D5x/E5x Family Data Sheet

## Public Key Cryptography Controller (PUKCC)

### 43.3.7.6.4 Parameters Definition

**Table 43-102. GF2NEcConvAffineToProjective Service Parameters**

Parameter	Type	Direction	Location	Data Length	Before Executing the Service	After Executing the Service
nu1ModBase	nu1	I	Crypto RAM	u2ModLength + 4	Base of modulus P	Base of modulus P
nu1CnsBase	nu1	I	Crypto RAM	u2ModLength + 8	Base of Cns	Base of Cns
u2ModLength	u2	I	–	–	Length of modulus P	Length of modulus P
nu1PointABase	nu1	I	Crypto RAM	3*u2ModLength + 12	Input point A	Resulting point A in affine coordinates
nu1Workspace	nu1	I	Crypto RAM	2*u2ModLength + 16	–	Workspace

### 43.3.7.6.5 Code Example

```

PUKCL_PARAM PUKCLParam;
P_PUKCL_PARAM pvPUKCLParam = &PUKCLParam;

// ! The Random Number Generator must be initialized and started
// ! following the directives given for the RNG on the chip

PUKCL (u2Option) = 0;

PUKCL_GF2NEcConvAffineToProjective(nu1ModBase) = <Base of the ram location of P>;
PUKCL_GF2NEcConvAffineToProjective(u2ModLength) = <Byte length of P>;
PUKCL_GF2NEcConvAffineToProjective(nu1CnsBase) = <Base of the ram location of Cns>;
PUKCL_GF2NEcConvAffineToProjective(nu1PointABase) = <Base of the ram location of the A point>;
PUKCL_GF2NEcConvAffineToProjective(nu1Workspace) = <Base of the ram location of the workspace>;
...

// vPUKCL_Process() is a macro command, which populates the service name
// and then calls the library...
vPUKCL_Process(GF2NEcConvAffineToProjective,&PUKCLParam);
if (PUKCL (u2Status) == PUKCL_OK)
{
    ...
}
else // Manage the error

```

### 43.3.7.6.6 Constraints

No overlapping between either input and output are allowed. The following conditions must be avoided to ensure that the service works correctly:

- nu1ModBase, nu1CnsBase, nu1PointABase, nu1Workspace are not aligned on 32-bit boundaries
- {nu1ModBase, u2ModLength + 4}, {nu1CnsBase, u2ModLength + 8}, {nu1PointABase, 3\*u2ModLength + 12}, {nu1Workspace, <WorkspaceLength>} are not in Crypto RAM
- u2ModLength is either: < 12, > 0xffc or not a 32-bit length
- All overlapping between {nu1ModBase, u2ModLength + 4}, {nu1CnsBase, u2ModLength + 8}, {nu1PointABase, 3\*u2ModLength + 12}, and {nu1Workspace, 2\*u2ModLength + 16}

# SAM D5x/E5x Family Data Sheet

## Public Key Cryptography Controller (PUKCC)

### 43.3.7.6.7 Status Returned Values

**Table 43-103. GF2NEcConvAffineToProjective Service Return Codes**

Returned Status	Importance	Meaning
PUKCL_OK	–	The computation passed without problem.

### 43.3.7.7 Randomize Coordinate

#### 43.3.7.7.1 Purpose

This service is used to convert the Projective representation of a point to another Projective representation.

#### 43.3.7.7.2 How to Use the Service

#### 43.3.7.7.3 Description

The operation performed is:

$$Projective(X_1, Y_1, Z_1) \rightarrow Projective(X_2, Y_2, Z_2)$$

In this computation, the following parameters need to be provided:

- The input point is filled in projective coordinates (X,Y,Z) (pointed by {nu1PointBase, 3\*u2ModLength + 12}). This Point must not be the point at infinity.
- Cns the Fast Modular Constant filled (pointed by {nu1CnsBase, u2ModLength + 8})
- P the modulus filled (pointed by {nu1ModBase, u2ModLength + 4})
- The workspace not initialized (pointed by {nu1WorkSpace, 3\*u2ModLength + 28})
- The random number (pointed by {nu1RandomBase, u2ModLength + 4}) The result is the point nu1PointBase with its (X,Y,Z) coordinates randomized. The service for this operation is GF2NEcRandomiseCoordinate.



#### **Important:**

Before using this service:

- Ensure that the constant Cns has been calculated with the Setup of the fast Modular Reductions service.
- Be sure to follow the directives given for the RNG on the chip you use (particularly initialization, seeding) and compulsorily start the RNG.

### 43.3.7.7.4 Parameters Definition

**Table 43-104. GF2NEcRandomiseCoordinate Service Parameters**

Parameter	Type	Direction	Location	Data Length	Before Executing the Service	After Executing the Service
nu1ModBase	nu1	I	Crypto RAM	u2ModLength + 4	Base of modulus P	Base of modulus P
nu1CnsBase	nu1	I	Crypto RAM	u2ModLength + 8	Base of Cns	Base of Cns
u2ModLength	u2	I	–	–	Length of modulus P	Length of modulus P

# SAM D5x/E5x Family Data Sheet

## Public Key Cryptography Controller (PUKCC)

.....continued

Parameter	Type	Direction	Location	Data Length	Before Executing the Service	After Executing the Service
nu1PointBase	nu1	I	Crypto RAM	3*u2ModLength + 12	Input point	Resulting point
nu1RandomBase	nu1	I	Crypto RAM	u2ModLength + 4	Random	Corrupted
nu1Workspace	nu1	I	Crypto RAM	3*u2ModLength + 28	–	Workspace

### 43.3.7.7.5 Code Example

```

PUKCL_PARAM PUKCLParam;
PUPUKCL_PARAM pvPUKCLParam = &PUKCLParam;

// ! The Random Number Generator must be initialized and started
// ! following the directives given for the RNG on the chip

PUKCL (u2Option) = 0;

// Depending on the option specified, not all fields should be filled
PUKCL_GF2NEcRandomiseCoordinate(nu1ModBase) = <Base of the ram location of P>;
PUKCL_GF2NEcRandomiseCoordinate(u2ModLength) = <Byte length of P>;
PUKCL_GF2NEcRandomiseCoordinate(nu1CnsBase) = <Base of the ram location of Cns>;
PUKCL_GF2NEcRandomiseCoordinate(nu1RandomBase) = <Base of the ram location where the the rng
is stored>;
PUKCL_GF2NEcRandomiseCoordinate(nu1PointBase) = <Base of the ram location of the point>;
PUKCL_GF2NEcRandomiseCoordinate(nu1Workspace) =
<Base of the ram location of the workspace>;
...

// vPUKCL_Process() is a macro command, which populates the service name
// and then calls the library...
vPUKCL_Process(GF2NEcRandomiseCoordinate,&PUKCLParam);
if (PUKCL (u2Status) == PUKCL_OK)
{
    ...
}
else // Manage the error

```

### 43.3.7.7.6 Constraints

No overlapping between either input and output are allowed. The following conditions must be avoided to ensure that the service works correctly:

- nu1ModBase, nu1CnsBase, nu1PointABase, nu1RandomBase, nu1Workspace are not aligned on 32-bit boundaries
- {nu1ModBase, u2ModLength + 4}, {nu1CnsBase, u2ModLength + 8}, {nu1PointABase, 3\*u2ModLength + 12}, {nu1RandomBase, u2ModLength + 4}, {nu1Workspace, <WorkspaceLength>} are not in Crypto RAM
- u2ModLength is either: < 12, > 0xffc or not a 32-bit length
- All overlapping between {nu1ModBase, u2ModLength + 4}, {nu1CnsBase, u2ModLength + 8}, {nu1PointABase, 3\*u2ModLength + 12}, {nu1RandomBase, u2ModLength + 4} and {nu1Workspace, 3\*u2ModLength + 28}

# SAM D5x/E5x Family Data Sheet

## Public Key Cryptography Controller (PUKCC)

### 43.3.7.7.7 Status Returned Values

**Table 43-105. GF2NEcRandomiseCoordinate Service Return Codes**

Returned Status	Importance	Meaning
PUKCL_OK	–	The computation passed without problem.

### 43.3.7.8 Point is on Elliptic Curve

#### 43.3.7.8.1 Purpose

This service is used to test whether the point is on the curve.

#### 43.3.7.8.2 How to Use the Service

#### 43.3.7.8.3 Description

The operation performed is:

Status = IsPointOnCurve(X, Y, Z);

In this computation, the following parameters need to be provided:

- The input points filled in projective coordinates (X, Y, Z) (pointed by {nu1PointBase, 3\*U2ModLength + 4}). This point can be point at infinity.
- AParam and BParam are the Elliptic Curve Equation parameters (pointed by {nu1AParam, u2ModLength+ 4} and {nu1BParam, u2ModLength + 4}).
- Cns the Fast Modular Constant filled (pointed by {nu1CnsBase, u2ModLength + 8})
- P the modulus filled (pointed by {nu1ModBase, u2ModLength + 8})
- The workspace not initialized (pointed by {nu1WorkSpace, 4\*u2ModLength + 28})

The service name for this operation is `GF2NEcPointIsOnCurve`.



**Important:** Before using this service, the constant Cns must have been calculated with the Fast Modular Reduction service.

### 43.3.7.8.4 Parameters Definition

**Table 43-106. GF2NEcPointIsOnCurve Service Parameters**

Parameter	Type	Dir.	Location	Data Length	Before Executing the Service	After Executing the Service
nu1ModBase	nu1	I	Crypto RAM	u2ModLength + 4	Base of modulus P	Base of modulus P
nu1CnsBase	nu1	I	Crypto RAM	u2ModLength + 8	Base of Cns	Base of Cns
u2ModLength	u2	I	–	–	Length of modulus P	Length of modulus P
nu1PointBase	nu1	I	Crypto RAM	3*u2ModLength + 12	Input point	Unchanged
nu1AParam	nu1	I	Crypto RAM	u2ModLength + 4	The parameter a	Unchanged
nu1BParam	nu1	I	Crypto RAM	u2ModLength + 4	The parameter b	Unchanged
nu1Workspace	nu1	I	Crypto RAM	4*u2ModLength + 28	N/A	Workspace

# SAM D5x/E5x Family Data Sheet

## Public Key Cryptography Controller (PUKCC)

### 43.3.7.8.5 Code Example

```

PUKCL_PARAM PUKCLParam;
P_PUKCL_PARAM pvPUKCLParam = &PUKCLParam;

// ! The Random Number Generator must be initialized and started
// ! following the directives given for the RNG on the chip

PUKCL (u2Option) = 0;

// Depending on the option specified, not all fields should be filled
PUKCL _GF2NEcPointIsOnCurve(nu1ModBase) = <Base of the ram location of P>;
PUKCL _GF2NEcPointIsOnCurve(u2ModLength) = <Byte length of P>;
PUKCL _GF2NEcPointIsOnCurve(nu1CnsBase) = <Base of the ram location of Cns>;
PUKCL _GF2NEcPointIsOnCurve(nu1PointABase) = <Base of the A point>;
PUKCL _GF2NEcPointIsOnCurve(nu1AParam) = <Base of the ram location of the parameter a>;
PUKCL _GF2NEcPointIsOnCurve(nu1BParam) = <Base of the ram location of the parameter b>;
PUKCL _GF2NEcPointIsOnCurve(nu1PointBase) = <Base of the ram location of the point>;
PUKCL _GF2NEcPointIsOnCurve(nu1Workspace) = <Base of the ram location of the workspace>;
...

// vPUKCL_Process() is a macro command, which populates the service name
// and then calls the library...
vPUKCL_Process(GF2NEcPointIsOnCurve,
pvPUKCLParam);
if (PUKCL (u2Status) == PUKCL_OK)
{
    ...
}
else // Manage the error

```

### 43.3.7.8.6 Constraints

No overlapping between either input and output are allowed. The following conditions must be avoided to ensure that the service works correctly:

- nu1ModBase, nu1CnsBase, nu1PointABase, nu1AParam, nu1BParam and nu1Workspace are not aligned on 32-bit boundaries
- {nu1ModBase, u2ModLength + 4}, {nu1CnsBase, u2ModLength + 8}, {nu1PointABase, 3\*u2ModLength + 12}, {nu1AParam, u2ModLength + 4}, {nu1BParam, u2ModLength + 4}, {nu1Workspace, 4\*u2ModLength + 28} are not in Crypto RAM
- u2ModLength is either: < 12, > 0xffc or not a 32-bit length
- All overlapping between {nu1ModBase, u2ModLength + 4}, {nu1CnsBase, u2ModLength + 8}, {nu1PointABase, 3\*u2ModLength + 12}, {nu1AParam, u2ModLength + 4}, {nu1BParam, u2ModLength + 4} and {nu1Workspace, 4\*u2ModLength + 28}

### 43.3.7.8.7 Status Returned Values

**Table 43-107. GF2NEcPointIsOnCurve Service Return Codes**

Returned Status	Importance	Meaning
PUKCL_OK	–	The point is on the curve.
PUKCL_POINT_IS_NOT_ON_CURVE	Warning	The point is not on the curve.
PUKCL_POINT_AT_INFINITY	Warning	The input point has its Z equal to zero, so it's a representation of the infinite point.

### 43.3.7.9 Generating an ECDSA Signature (Compliant with FIPS 186-2)

#### 43.3.7.9.1 Purpose

This service is used to generate an ECDSA signature following the FIPS 186-2. It performs the second step of the Signature Generation. A hash value (HashVal) must be provided as input, it has to be previously computed from the message to be signed using a secure hash algorithm.

# SAM D5x/E5x Family Data Sheet

## Public Key Cryptography Controller (PUKCC)

A scalar number must be provided, as described in the FIPS 186-2.

The result (R,S) is computed by this service. If S equals zero, the status is set to PUKCL\_WRONG\_SELECT\_NUMBER.

### 43.3.7.9.2 How to Use the Service

#### 43.3.7.9.3 Description

The operation performed is:

$$(R, S) = EcDsaSign(Pt_A, HashVal, k, CurveParameters, PrivateKey)$$

This service processes the following checks:

- If the Scalar Number  $k$  is out of the range  $[1, \text{PointOrder} - 1]$ , the calculus is stopped and the status is set to PUKCL\_WRONG\_SELECT\_NUMBER.
- If  $R$  equals zero, the calculus is stopped and the status is set to PUKCL\_WRONG\_SELECT\_NUMBER.
- If  $S$  equals zero, the calculus is stopped and the status is set to PUKCL\_WRONG\_SELECT\_NUMBER. In this computation, the following parameters need to be provided:
- A the input point is filled in “mixed” coordinates (X,Y) with the affine values and  $Z = 1$  (pointed by  $\{\text{nu1PointABase}, 3 * \text{u2ModLength} + 12\}$ )
- Cns the working space for the Fast Modular Constant not initialized (pointed by  $\{\text{nu1CnsBase}, \text{u2ScalarLength} + 8\}$ )
- P the modulus filled (pointed by  $\{\text{nu1ModBase}, \text{u2ModLength} + 4\}$ )
- The workspace not initialized (pointed by  $\{\text{nu1WorkSpace}, 8 * \text{u2ModLength} + 44\}$ )
- The  $a$  and  $b$  parameters relative to the elliptic curve equation (pointed by  $\{\text{nu1ABBase}, 2 * \text{u2ModLength} + 8\}$ )
- The order of the Point A on the elliptic curve (pointed by  $\{\text{nu1OrderPointBase}, \text{u2ScalarLength} + 4\}$ )
- $k$  the input Scalar Number beforehand generated and filled (pointed by  $\{\text{nu1ScalarNumber}, \text{u2ScalarLength} + 4\}$ )
- HashVal the hash value beforehand generated and filled (pointed by  $\{\text{nu1HashBase}, \text{u2ScalarLength} + 4\}$ )
- The Private Key (pointed by  $\{\text{nu1PrivateKey}, \text{u2ScalarLength} + 4\}$ )
- Generally  $\text{u2ScalarLength}$  is equal to  $(\text{u2ModLength})$  or  $(\text{u2ModLength} + 4)$



#### Important:

For the ECDSA signature generation be sure to follow the directives given for the RNG on the chip you use (particularly initialization, seeding) and compulsorily start the RNG.

The scalar number  $k$  must be selected at random. This random must be generated before the call of the ECDSA signature. For this random generation be sure to follow the directives given for the RNG on the chip you use (particularly initialization, seeding) and compulsorily start the RNG.

The operation performed is:

- Compute the ECDSA (R,S) as described in FIPS 186-2, but leaving the user the role of computing the input Hash Value, thus leaving the freedom of using any other algorithm than SHA-1.
- Compute a  $R$  value using the input A point and the scalar number.



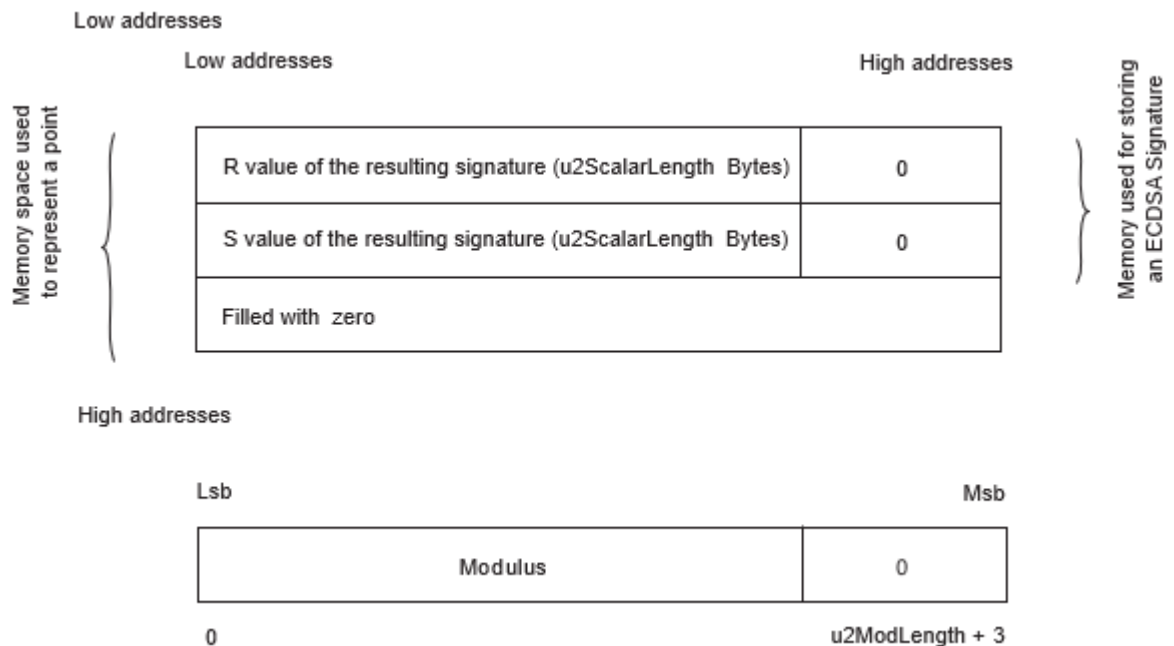
# SAM D5x/E5x Family Data Sheet

## Public Key Cryptography Controller (PUKCC)

- Compute a S value using R, the scalar number, the private key and the provided hash value. Note that the resulting signature (R,S) is stored at the place of the input A point.
- If all is correct and S is different from zero, the status is set to PUKCL\_OK. If all is correct and S equals zero, the status is set to PUKCL\_WRONG\_SELECT\_NUMBER. If an error occurs, the status is set to the corresponding error value (see Status Returned Values below).

The service name for this operation is GF2NEcDsaGenerateFast. The fast mode is used, the fast modular reduction is used in the computations.

- The signature (R,S), when resulting from a computation is given back at address of the A point:
  - The R value result with  $u2ModLength + 4$  bytes (padded with zeros).
  - The S value result with  $u2ModLength + 4$  bytes (padded with zeros)
  - The  $u2NLength + 4$  following bytes (space for the third coordinate of A) are filled with zeros.



### 43.3.7.9.4 Parameters Definition

**Table 43-108. GF2NEcDsaGenerateFast Service Parameters**

Parameter	Type	Direction	Location	Data Length	Before Executing the Service	After Executing the Service
nu1ModBase	nu1	I	Crypto RAM	$u2ModLength + 4$	Base of modulus P	Base of modulus P
nu1CnsBase	nu1	I	Crypto RAM	$u2ScalarLength + 12$	Base of Cns	Base of Cns
u2ModLength	u2	I	–	–	Length of modulus P	Length of modulus P

# SAM D5x/E5x Family Data Sheet

## Public Key Cryptography Controller (PUKCC)

.....continued

Parameter	Type	Direction	Location	Data Length	Before Executing the Service	After Executing the Service
nu1ScalarNumber	nu1	I	Crypto RAM	u2ScalarLength + 4	Scalar Number used to multiply the point A	Unchanged
nu1OrderPointBase	nu1	I	Crypto RAM	u2ScalarLength + 4	Order of the Point A in the elliptic curve	Unchanged
nu1PrivateKey	nu1	I/O	Crypto RAM	u2ScalarLength + 4	Base of the Private Key	Unchanged
nu1HashBase (see <b>Note 1</b> )	nu1	I	Crypto RAM	u2ScalarLength + 4	Base of the hash value resulting from the previous SHA	Unchanged
u2ScalarLength	u2	I	–	–	Length of scalar (same length as the length of order)	Length of scalar
nu1PointABase	nu1	I/O	Crypto RAM	3*u2ModLength + 12	Input point A (three coordinates (X,Y) affine and Z = 1)	Resulting signature (R,S,0)
nu1ABase	nu1	I	Crypto RAM	2*u2ModLength + 8	Parameter a of the elliptic curve	Unchanged
nu1Workspace	nu1	I	Crypto RAM	8*u2ModLength + 44	–	Corrupted workspace

**Note:**

1. Whatever the chosen SHA, the resulting hash value may have a length inferior or equal to the modulo length and be padded with zeros until its total length is u2ModLength + 4.

**43.3.7.9.5 Code Example**

```

PUKCL_PARAM PUKCLParam;
PPUKCL_PARAM pvPUKCLParam = &PUKCLParam;

// ! The Random Number Generator must be initialized and started
// ! following the directives given for the RNG on the chip

PUKCL (u2Option) = 0;

// Depending on the option specified, not all fields should be filled
PUKCL _GF2NEcDsaGenerate(nulModBase) = <Base of the ram location of P>;
PUKCL _GF2NEcDsaGenerate(u2ModLength) = <Byte length of P>;
PUKCL _GF2NEcDsaGenerate(nulCnsBase) = <Base of the ram location of Cns>;
PUKCL _GF2NEcDsaGenerate(nulPointABase) = <Base of the A point>;
PUKCL _GF2NEcDsaGenerate(nulPrivateKey) = <Base of the Private Key>;

```

# SAM D5x/E5x Family Data Sheet

## Public Key Cryptography Controller (PUKCC)

```

PUKCL_GF2NEcDsaGenerate(nu1ScalarNumber) = <Base of the ScalarNumber>;
PUKCL_GF2NEcDsaGenerate(nu1OrderPointBase) = <Base of the order of A point>;
PUKCL_GF2NEcDsaGenerate(nu1ABase) = <Base of the a parameter of the curve>; PUKCL
_GF2NEcDsaGenerate(nu1Workspace) = <Base of the workspace>;
PUKCL_GF2NEcDsaGenerate(nu1HashBase) = <Base of the SHA resulting hash>;
...

// vPUKCL_Process() is a macro command, which populates the service name
// and then calls the library...
vPUKCL_Process(GF2NEcDsaGenerateFast, pvPUKCLParam);
if (PUKCL (u2Status) == PUKCL_OK)
    {
        ...
    }
else // Manage the error

```

### 43.3.7.9.6 Constraints

No overlapping between either input and output are allowed. The following conditions must be avoided to ensure the service works correctly:

- nu1ModBase, nu1CnsBase, nu1PointABase, nu1PrivateKey, nu1ScalarNumber, nu1OrderPointBase, nu1ABase, nu1Workspace or nu1HashBase are not aligned on 32-bit boundaries
- {nu1ModBase, u2ModLength + 4}, {nu1CnsBase, u2ModLength + 8}, {nu1PointABase, 3\*u2ModLength + 12}, {nu1PrivateKey, u2ScalarLength + 4}, {nu1ScalarNumber, u2ScalarLength + 4}, {nu1OrderPointBase, u2ScalarLength + 4}, {nu1ABase, u2ModLength + 4}, {nu1Workspace, <WorkspaceLength>} or {nu1HashBase, u2ScalarLength + 4} are not in Crypto RAM
- u2ModLength is either: < 12, > 0xffc or not a 32-bit length
- All overlapping between {nu1ModBase, u2ModLength + 4}, {nu1CnsBase, u2ModLength + 8}, {nu1PointABase, 3\*u2ModLength + 12}, {nu1PrivateKey, u2ScalarLength + 4}, {nu1ScalarNumber, u2ScalarLength + 4}, {nu1OrderPointBase, u2ScalarLength + 4}, {nu1ABase, u2ModLength + 4}, {nu1Workspace, <WorkspaceLength>} and {nu1HashBase, u2ScalarLength + 4}

### 43.3.7.9.7 Status Returned Values

**Table 43-109. GF2NEcDsaGenerate Fast Service Return Codes**

Returned Status	Importance	Meaning
PUKCL_OK	–	The computation passed without problem.
PUKCL_WRONG_SELECTNUMBER	Warning	The given value for nu1ScalarNumber is not good to perform this signature generation.

### 43.3.7.10 Verifying an ECDSA Signature (Compliant with FIPS 186-2)

#### 43.3.7.10.1 Purpose

This service is used to verify an ECDSA signature following the FIPS 186-2. It performs the second step of the Signature Verification.

A hash value (HashVal) must be provided as input, it has to be previously computed from the message to be signed using a secure hash algorithm.

As second significant input, the Signature is provided to be checked. This service checks the signature and fills the status accordingly.

#### 43.3.7.10.2 How to Use the Service

#### 43.3.7.10.3 Description

The operation performed is:

# SAM D5x/E5x Family Data Sheet

## Public Key Cryptography Controller (PUKCC)

$Verify = EcDsaVerifySignature(Pt_A, HashVal, Signature, CurveParameters, PublicKey)$

The points used for this operation are represented in different coordinate systems. In this computation, the following parameters need to be provided:

- A the input point is filled with the affine values (X,Y) and Z = 1 (pointed by {nu1PointABase, 3\*u2ModLength + 12})
- Cns the working space for the Fast Modular Constant not initialized (pointed by {nu1CnsBase,u2ScalarLength + 8})
- P the modulus filled (pointed by {nu1ModBase,u2ModLength +4})
- The workspace not initialized (pointed by {nu1WorkSpace, 8\*u2ModLength +44}) The a and b parameters relative to the elliptic curve (pointed by {nu1ABase,2\*u2ModLength + 8})
- The order of the Point A on the elliptic curve (pointed by {nu1OrderPointBase,u2ScalarLength +4})
- HashVal the hash value beforehand generated and filled (pointed by {nu1HashBase,u2ScalarLength +4})
- The Public Key point is filled in “mixed” coordinates (X,Y) with the affine values and Z = 1 (pointed by {nu1PointPublicKeyGen, 3\*u2ModLength + 12})
- The input signature (R,S), even if it is not a Point, is represented in memory like a point in affine coordinates (X,Y) (pointed by {nu1PointSignature, 2\*u2ScalarLength + 8})



**Important:** For the ECDSA signature verification be sure to follow the directives given for the RNG on the chip you use (particularly initialization, seeding) and compulsorily start the RNG.

- The operation consists in obtaining a V value with all these input parameter and check that V equals the provided R. If all is correct and the signature is the good one, the status is set to PUKCL\_OK. If all is correct and the signature is wrong, the status is set to PUKCL\_WRONG\_SIGNATURE. If an error occurs, the status is set to the corresponding error value (see Status Returned Values below).

The service name for this operation is `GF2NEcDsaVerifyFast`. This service uses Fast mode and Fast Modular Reduction for computation.

#### 43.3.7.10.4 Parameters Definition

**Table 43-110. GF2NEcDsaVerifyFast Service Parameters**

Parameter	Type	Direction	Location	Data Length	Before Executing the Service	After Executing the Service
nu1ModBase	nu1	I	Crypto RAM	u2ModLength + 4	Base of modulus P	Base of modulus P
nu1CnsBase	nu1	I	Crypto RAM	u2ScalarLength + 8	Base of Cns	Base of Cns
u2ModLength	u2	I	–	–	Length of modulus P	Length of modulus P
nu1OrderPointBase	nu1	I	Crypto RAM	u2ScalarLength + 4	Order of the Point A in the elliptic curve	Unchanged

# SAM D5x/E5x Family Data Sheet

## Public Key Cryptography Controller (PUKCC)

.....continued						
Parameter	Type	Direction	Location	Data Length	Before Executing the Service	After Executing the Service
nu1PointSignature	nu1	I	Crypto RAM	2*u2ScalarLength + 8	Signature(r, s)	Corrupted
nu1HashBase (see <b>Note 1</b> )	nu1	I	Crypto RAM	u2ScalarLength + 4	Base of the hash value resulting from the previous SHA	Corrupted
u2ScalarLength	u2	I	–	–	Length of scalar	Length of scalar
nu1PointABase	nu1	I/O	Crypto RAM	3*u2ModLength + 12	Generator point	Corrupted
nu1PointPublicKeyGen	nu1	I/O	Crypto RAM	3*u2ModLength + 12	Public point	Corrupted
nu1ABase	nu1	I	Crypto RAM	2*u2ModLength + 8	Parameter a and b of the elliptic curve	Unchanged
nu1Workspace	nu1	I	Crypto RAM	8*u2ModLength + 44	–	Corrupted workspace

**Note:**

1. Whatever the chosen SHA, the resulting hash value may have a length inferior or equal to the modulo length and be padded with zeros until its total length is u2ModLength + 4.

### 43.3.7.10.5 Code Example

```

PUKCL_PARAM PUKCLParam;
P_PUKCL_PARAM pvPUKCLParam = &PUKCLParam;

// ! The Random Number Generator must be initialized and started
// ! following the directives given for the RNG on the chip

PUKCL (u2Option) = 0;

// Depending on the option specified, not all fields should be filled PUKCL
_PUKCL_GF2NEcDsaVerify(nulModBase) = <Base of the ram location of P>;
_PUKCL_GF2NEcDsaVerify(u2ModLength) = <Byte length of P>;
_PUKCL_GF2NEcDsaVerify(nulCnsBase) = <Base of the ram location of Cns>;
_PUKCL_GF2NEcDsaVerify(nulPointABase) = <Base of the A point>;
_PUKCL_GF2NEcDsaVerify(nulPrivateKey) = <Base of the Private Key>;
_PUKCL_GF2NEcDsaVerify(nulScalarNumber) = <Base of the ScalarNumber>;
_PUKCL_GF2NEcDsaVerify(nulOrderPointBase) = <Base of the order of A point>;
_PUKCL_GF2NEcDsaVerify(nulABase) = <Base of the a parameter of the curve>; PUKCL
_GF2NEcDsaVerify(nulWorkspace) = <Base of the workspace>;
_PUKCL_GF2NEcDsaVerify(nulHashBase) = <Base of the SHA resulting hash>;
...

// vPUKCL_Process() is a macro command, which populates the service name
// and then calls the library...
vPUKCL_Process(GF2NEcDsaVerifyFast, &PUKCLParam);
if (PUKCL (u2Status) == PUKCL_OK)
{
    ...
}

```

```

    }
else
    if (PUKCL(u2Status) == PUKCL_WRONG_SIGNATURE)
    {
        ...
    }
else // Manage the error

```

### 43.3.7.10.6 Constraints

No overlapping between either input and output are allowed. The following conditions must be avoided to ensure the service works correctly:

- nu1ModBase, nu1CnsBase, nu1PointABase, nu1PointPublicKeyGen, nu1PointSignature, nu1OrderPointBase, nu1ABase, nu1Workspace or nu1HashBase are not aligned on 32-bit boundaries
- {nu1ModBase, u2ModLength + 4}, {nu1CnsBase, u2ModLength + 8}, {nu1PointABase, 3\*u2ModLength + 12}, {nu1PointPublicKeyGen, 3\*u2ModLength + 12}, {nu1PointSignature, 2\*u2ScalarLength + 8}, {nu1OrderPointBase, u2ScalarLength + 4}, {nu1ABase, 2\*u2ModLength + 8}, {nu1Workspace, <WorkspaceLength>} or {nu1HashBase, u2ScalarLength + 4} are not in Crypto RAM
- u2ModLength is either: < 12, > 0xffc or not a 32-bit length
- All overlapping between {nu1ModBase, u2ModLength + 4}, {nu1CnsBase, u2ModLength + 8}, {nu1PointABase, 3\*u2ModLength + 12}, {nu1PointPublicKeyGen, 3\*u2ModLength + 12}, {nu1PointSignature, 2\*u2ScalarLength + 8}, {nu1OrderPointBase, u2ScalarLength + 4}, {nu1ABase, 2\*u2ModLength + 8}, {nu1Workspace, <WorkspaceLength>} and {nu1HashBase, u2ScalarLength + 4}

### 43.3.7.10.7 Status Returned Values

**Table 43-111. GF2NEcdsaVerifyFast Service Return Codes**

Returned Status	Importance	Meaning
PUKCL_OK	–	The computation passed without errors. The signature is correct.
PUKCL_WRONG_SIGNATURE	Warning	The signature is incorrect.

## 43.3.8 PUKCL Requirements and Performance

### 43.3.8.1 Services Stack Usage

This library is using the main core to execute its computations, and therefore is also sharing some resources with the application.

It may be important for the application to know RAM usage by the library functions and to be aware that the library does not use any global variables.

The following table provides the minimum number of bytes used by the library that have to be available on the stacks to ensure that the functionality can be executed correctly. In some cases, the library may use less bytes than the specified number for some options. This table contains estimated values.

**Table 43-112. Services Stack Usage**

PUKCL Service	STACK Usage (Bytes)
SelfTest	112
ClearFlags	0

# SAM D5x/E5x Family Data Sheet

## Public Key Cryptography Controller (PUKCC)

.....continued	
PUKCL Service	STACK Usage (Bytes)
Swap	8
Fill	8
CondCopy	24
FastCopy	16
Smult	16
Smult (with reduction)	88
Comp	8
Fmult	24
Fmult (with reduction)	96
Square	16
Square (with reduction)	88
Div	144
GCD	136
RedMod (Setup)	160
RedMod (using fast reduction)	80
RedMod (randomize)	80
RedMod (Normalize)	80
RedMod (Using Division)	184
ExpMod	200
PrimeGen	416
CRT	304
ZpEccAddFast	104
ZpEccAddSubFast	92
ZpEcConvProjToAffine	280
ZpEcConvAffineToProjective	64
ZpEccDbfFast	96
ZpEccMulFast	168
ZpEccQuickDualMulFast	216
ZpEcDsaGenerateFast	392
ZpEcDsaVerifyFast	456
ZpEcDsaQuickVerify	368

# SAM D5x/E5x Family Data Sheet

## Public Key Cryptography Controller (PUKCC)

.....continued	
PUKCL Service	STACK Usage (Bytes)
ZpEcRandomiseCoordinate	56
GF2NEccAddFast	128
GF2NEcConvProjToAffine	264
GF2NEcConvAffineToProjective	56
GF2NEccDblFast	136
GF2NEccMulFast	208
GF2NEcDsaGenerateFast	376
GF2NEcDsaVerifyFast	440
GF2NEcRandomiseCoordinate	56

### 43.3.8.2 Parameter Size Limits for Different Services

The following table lists parameter size limits for different services.

For the services ModExp, PrimeGen, and CRT, additional details are available in the service description.

**Table 43-113. Parameter Size Limits**

API	Min/Max Sizes	Comments
SelfTest	–	–
ClearFlags	–	–
Swap	4 bytes to 2044 bytes	Per block to be swapped
Fill	4 bytes to 4088 bytes	–
Fast Copy/Clear	4 bytes to 2044 bytes	Supposing Length(R) = Length(X)
Conditional Copy/Clear	4 bytes to 2044 bytes	Supposing Length(R) = Length(X)
Smult	4 bytes to 2040 bytes	Supposing Length(R) = Length(X) + 4 Bytes, No Z Parameter, No Reduction
Compare	4 bytes to 2044 bytes	Supposing Length(X) = Length(Y)
FMult	Input: 4 bytes to 1020 bytes Output: 4 bytes to 2040 bytes	Supposing Length(Y) = Length(X), No Z Parameter, No Reduction
Square	Input: 4 bytes to 1020 bytes Output: 4 bytes to 2040 bytes	Supposing No Z Parameter, No Reduction
Euclidean Division	Divider: 8 to 1016 bytes Num.: 8 to 2032 bytes	Supposing Length(Num) = 2*Length(Divider)
Mod. inv. / GCD	8 to 1012 bytes	–



# SAM D5x/E5x Family Data Sheet

## Public Key Cryptography Controller (PUKCC)

.....continued		
API	Min/Max Sizes	Comments
ModRed	Modulus: 12 to 1016 bytes Input: 24 to 2032 bytes	Supposing RBase = XBase
Fast ModExp Exp in Crypto RAM	12 to 576 bytes (96 to 4608 bits)	Supposing Length(Exponent) = Length(Modulus), Window Size = 1 With the Exponent in Crypto RAM
Fast ModExp Exp not in Crypto RAM	12 to 672 bytes (96 to 5376 bits)	Supposing Length(Exponent) = Length(Modulus), Window Size = 1 With the Exponent not in Crypto RAM
Prime Gen.	Prime Number: 12 to 448 bytes (96 to 3584 bits)	Supposing Window Size = 1
CRT	Modulus = Two Primes: Size of one prime from 24 to 448 bytes Modulus = from 48 to 896 bytes (384 to 7168 bits)	Supposing Length(Exponent) = Length(Modulus), Window Size = 1
ECC Addition and Subtraction GF(p)	Modulus: 12 to 308 bytes	–
ECC Doubling GF(p)	Modulus: 12 to 400 bytes	–
ECC Multiplication GF(p)	Modulus: 12 to 264 bytes	Supposing Length(Scalar) = Length(Modulus)
ECC Quick Dual Multiplication GF(p)	Modulus: 12 to 152 bytes	–
ECDSA Generate GF(p)	Modulus: 12 to 220 bytes (up to 521 bits for common curves)	Supposing Length(Scalar) = Length(Modulus)
ECDSA Verify GF(p)	Modulus: 12 to 188 bytes (up to 521 bits for common curves)	Supposing Length(Scalar) = Length(Modulus)
ECC Addition GF(2n)	Modulus: 12 to 248 bytes	–
ECC Doubling GF(2n)	Modulus: 12 to 364 bytes	–
ECC Multiplication GF(2n)	Modulus: 12 to 250 bytes	Supposing Length(Scalar) = Length(Modulus)
ECDSA Generate GF(2n)	Modulus: 12 to 208 bytes (up to 571 bits for common curves)	Supposing Length(Scalar) = Length(Modulus)

# SAM D5x/E5x Family Data Sheet

## Public Key Cryptography Controller (PUKCC)

.....continued		
API	Min/Max Sizes	Comments
ECDSA Verify GF(2n)	Modulus: 12 to 180 bytes (up to 571 bits for common curves)	Supposing Length(Scalar) = Length(Modulus)
ECDSA Quick Verify GF(2n)	Modulus: 12 to 140 bytes (up to 571 bits for common curves)	Supposing Length(Scalar) = Length(Modulus)

### 43.3.8.3 Service Timing

The values in the following tables are estimated performances for CPU clock of 120 MHz. The CPU and PUKCC are operated at the same frequency. Due to possible change in the parameters values, the measurements show approximated values.

Other test conditions:

- PUKCL library data in Crypto RAM
- Test code and test data in SRAM
- ICache and DCache are disabled

#### 43.3.8.3.1 Service Timing for RSA

RSA uses the ExpMod service for encryption and decryption. Following tables show service timing, where 'W' indicates window size.

**Table 43-114. RSA1024**

Operation	Clock Cycles	Timing one block
RSA 1024 decryption / signature generation. No CRT, Regular implementation, W=4	3.05 MCycles	25.42 ms
RSA 1024 decryption / signature generation. With CRT, Regular implementation, W=4	1.04 MCycles	8.67 ms
RSA 1024 encryption / signature verification. No CRT, Fast implementation, W=1 Exponent=3	0.07 MCycles	0.58 ms
RSA 1024 encryption / signature verification. No CRT, Fast implementation, W=1 Exponent=0x10001	0.07 MCycles	0.58 ms

**Table 43-115. RSA2048**

Operation	Clock Cycles	Timing One block
RSA 2048 decryption / signature generation. No CRT, Regular implementation, W=4	21.9 MCycles	182 ms
RSA 2048 decryption / signature generation. With CRT, Regular implementation, W=4	6.19 MCycles	51.6 ms

# SAM D5x/E5x Family Data Sheet

## Public Key Cryptography Controller (PUKCC)

.....continued

Operation	Clock Cycles	Timing One block
RSA 2048 encryption / signature verification. No CRT, Fast implementation, W=1 Exponent=3	0.24 MCycles	2 ms
RSA 2048 encryption / signature verification. No CRT, Fast implementation, W=1 Exponent=0x10001	0.24 MCycles	2 ms

**Table 43-116. RSA4096**

Operation	Clock Cycles	Timing One block
RSA 4096 Decryption / signature generation. No CRT, Regular implementation, W=1	208 MCycles	1.73s
RSA 4096 Decryption / signature generation. With CRT, Regular implementation, W=3	45.5 MCycles	379 ms
RSA 4096 encryption / signature verification. No CRT, Fast implementation, W=1 Exponent=3	0.92 MCycles	7.67 ms
RSA 4096 encryption / signature verification. No CRT, Fast implementation, W=1 Exponent=0x10001	0.92 MCycles	7.67 ms

### 43.3.8.3.2 Service Timing for Prime Generation

Prime generation uses the PrimeGen service.

**Table 43-117. Prime Generation**

Operation	Clock Cycles	Timing One Block
Regular Generation of two primes, Prime_Length=512 bits, W=4, Rabin Miller Iterations Number = 3, (average of 200 samples)	Mean = 47.4 MCycles	Mean = 0.40s
Regular Generation of two primes, Prime_Length=512 bits, W=4, Rabin Miller Iterations Number = 3, (Standard Deviation for 200 samples)	Std Dev = 30.3 MCycles	Std Dev = 0.25s
Regular Generation of two primes, Prime_Length=1024 bits, W=4, Rabin Miller Iterations Number = 3, (average of 200 samples)	Mean = 448 MCycles	Mean = 3.73s
Regular Generation of two primes, Prime_Length=1024 bits, W=4, Rabin Miller Iterations Number = 3, (Standard Deviation for 200 samples)	Std Dev = 294 MCycles	Std Dev = 2.45s
Regular Generation of two primes, Prime_Length=2048 bits, W=4, Rabin Miller Iterations Number = 3, (average of 200 samples)	Mean = 4.78 GCycles	Mean = 39.8s

# SAM D5x/E5x Family Data Sheet

## Public Key Cryptography Controller (PUKCC)

.....continued

Operation	Clock Cycles	Timing One Block
Regular Generation of two primes, Prime_Length=2048 bits, W=4, Rabin Miller Iterations Number = 3, (Standard Deviation for 200 samples)	Std Dev = 3,05 GCycles	Std Dev = 25.4s

### 43.3.8.3.3 Service Timing for ECDSA on Prime Field

In the following table, ECDSA signature generation uses the ZpEcDsaGenerateFast service and signature verification uses ZpEcDsaQuickVerify

**Table 43-118. ECDSA GF(p)**

Operation	Clock Cycles	Timing One block
ECDSA GF(p) 256 Generate Fast	2.72 MCycles	22.7 ms
ECDSA GF(p) 256 Verify Quick W=(6,6) Scalar in Classical RAM	1.78 MCycles	14.8 ms
ECDSA GF(p) 256 Verify Quick W=(4,4) Scalar in PUKCC RAM	1.83 MCycles	15.2 ms
ECDSA GF(p) 384 Generate Fast	6.28 MCycles	52.3 ms
ECDSA GF(p) 384 Verify Quick W=(5,5) Scalar in Classical RAM	3.93 MCycles	32.8 ms
ECDSA GF(p) 384 Verify Quick W=(4,4) Scalar in PUKCC RAM	4.09 MCycles	34.1 ms
ECDSA GF(p) 521 Generate Fast	13.4 MCycles	112 ms
ECDSA GF(p) 521 Verify Quick W=(4,5) Scalar in Classical RAM	8.4 MCycles	70.3 ms
ECDSA GF(p) 521 Verify Quick W=(4,4) Scalar in PUKCC RAM	8.6 MCycles	72ms

### 43.3.8.3.4 Service Timing for ECDSA on Binary Field

In the following table, ECDSA signature generation uses the GF2NEcDsaGenerateFast service and signature verification uses GF2NEcDsaVerifyFast

**Table 43-119. ECDSA GF(2<sup>n</sup>)**

Operation	CPU Cycles	Timing One block
ECDSA GF(2 <sup>n</sup> ) B283 Generate Fast	3.21 MCycles	26.8 ms
ECDSA GF(2 <sup>n</sup> ) B283 Verify	6.44 MCycles	53.5 ms
ECDSA GF(2 <sup>n</sup> ) B409 Generate Fast	6.93 Mcycles	57.8 ms

# SAM D5x/E5x Family Data Sheet

## Public Key Cryptography Controller (PUKCC)

.....continued

Operation	CPU Cycles	Timing One block
ECDSA GF(2 <sup>n</sup> ) B409 Verify	13.8 Mcycles	115 ms
ECDSA GF(2 <sup>n</sup> ) B571 Generate Fast	15.1 Mcycles	125 ms
ECDSA GF(2 <sup>n</sup> ) B571 Verify	30.1 MCycles	251 ms

### 44. TRNG – True Random Number Generator

#### 44.1 Overview

The True Random Number Generator (TRNG) generates unpredictable random numbers that are not generated by an algorithm. It passes the American NIST Special Publication 800-22 and Diehard Random Tests Suites.

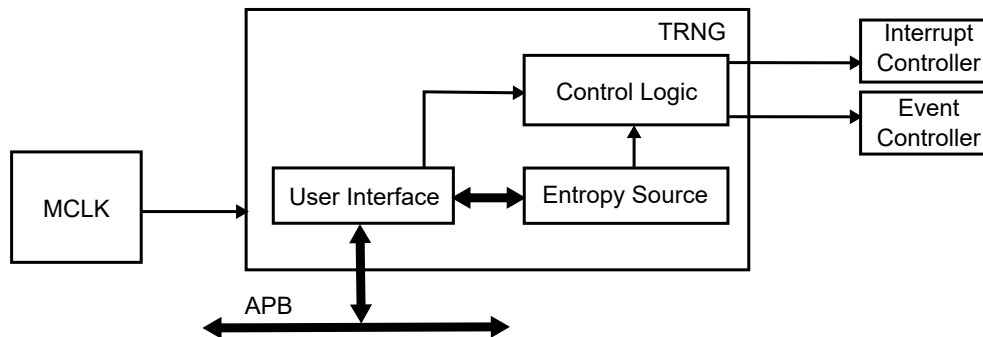
The TRNG may be used as an entropy source for seeding an NIST approved DRNG (Deterministic RNG) as required by FIPS PUB 140-2 and 140-3.

#### 44.2 Features

- Passed NIST Special Publication 800-22 Tests Suite
- Passed Diehard Random Tests Suite
- May be used as Entropy Source for seeding an NIST approved DRNG (Deterministic RNG) as required by FIPS PUB 140-2 and 140-3
- Provides a 32-bit random number every 84 clock cycles

#### 44.3 Block Diagram

Figure 44-1. TRNG Block Diagram.



#### 44.4 Signal Description

Not applicable.

#### 44.5 Product Dependencies

In order to use this peripheral, other parts of the system must be configured correctly, as described below.

##### 44.5.1 I/O Lines

Not applicable.

##### 44.5.2 Power Management

The functioning of TRNG depends on the sleep mode of device.

The TRNG interrupts can be used to wake up the device from sleep modes. Events connected to the event system can trigger other operations in the system without exiting sleep modes.

### Related Links

[18. PM – Power Manager](#)

[44.6.5 Sleep Mode Operation](#)

### 44.5.3 Clocks

The TRNG bus clock (CLK\_TRNG\_APB) can be enabled and disabled in the Main Clock module, and the default state of CLK\_TRNG\_APB can be found in *Peripheral Clock Masking*.

### Related Links

[15.6.2.6 Peripheral Clock Masking](#)

### 44.5.4 DMA

Not applicable.

### 44.5.5 Interrupts

The interrupt request line is connected to the interrupt controller. Using the TRNG interrupt(s) requires the interrupt controller to be configured first. Refer to NVIC - Nested Interrupt *Nested Vector Interrupt Controller* for details.

### Related Links

[10.2 Nested Vector Interrupt Controller](#)

### 44.5.6 Events

TRNG can generate Events that are used by the Event System (EVSYS) and EVSYS users.

TRNG cannot use any Events from other peripherals, as it is not an Event User.

### Related Links

[31. EVSYS – Event System](#)

### 44.5.7 Debug Operation

When the CPU is halted in debug mode the TRNG continues normal operation. If the TRNG is configured in a way that requires it to be periodically serviced by the CPU through interrupts or similar, improper operation or data loss may result during debugging.

### 44.5.8 Register Access Protection

All registers with write-access are optionally write-protected by the Peripheral Access Controller (PAC), except the following register:

Interrupt Flag Status and Clear (INTFLAG) register

Optional write protection by the Peripheral Access Controller (PAC) is denoted by the "PAC Write Protection" property in each individual register description.

### 44.5.9 Analog Connections

Not applicable.

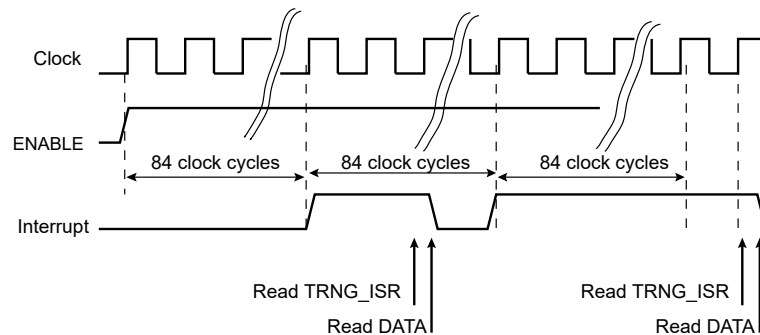
### 44.6 Functional Description

#### 44.6.1 Principle of Operation

When the TRNG is enabled, the peripheral starts providing new 32-bit random numbers every 84 CLK\_TRNG\_APB clock cycles.

The TRNG can be configured to generate an interrupt or event when a new random number is available.

**Figure 44-2. TRNG Data Generation Sequence**



#### 44.6.2 Basic Operation

##### 44.6.2.1 Initialization

To operate the TRNG, do the following:

- Configure the clock source for CLK\_TRNG\_APB in the Main Clock Controller (MCLK) and enable the clock by writing a '1' to the TRNG bit in the APB Mask register of the MCLK.
- Optional: Enable the output event by writing a '1' to the EVCTRL.DATARDYEO bit.
- Optional: Enable the TRNG to Run in Standby sleep mode by writing a '1' to CTRLA.RUNSTDBY.
- Enable the TRNG operation by writing a '1' to CTRLA.ENABLE.

The following register is enable-protected, meaning that it can only be written when the TRNG is disabled (CTRLA.ENABLE is zero):

- Event Control register (EVCTRL)

Enable-protection is denoted by the Enable-Protected property in the register description.

##### 44.6.2.2 Enabling, Disabling and Resetting

The TRNG is enabled by writing '1' to the Enable bit in the Control A register (CTRLA.ENABLE). The TRNG is disabled by writing a zero to CTRLA.ENABLE.

#### 44.6.3 Interrupts

The TRNG has the following interrupt source:

- Data Ready (DATARDY): Indicates that a new random number is available in the DATA register and ready to be read.  
This interrupt is a synchronous wake-up source. See *Sleep Mode Controller* for details.

The interrupt source has an interrupt flag associated with it. The interrupt flag in the Interrupt Flag Status and Clear register (INTFLAG.DATARDY) is set to '1' when the interrupt condition occurs. The interrupt can be enabled by writing a '1' to the corresponding bit in the Interrupt Enable Set register (INTENSET.DATARDY), and disabled by writing a '1' to the corresponding bit in the Interrupt Enable Clear (INTENCLR) register.



An interrupt request is generated when the interrupt flag is set and the corresponding interrupt is enabled. The interrupt request remains active until the interrupt flag is cleared, or the interrupt is disabled. See [44.8.5 INTFLAG](#) for details on how to clear interrupt flags.

Note that interrupts must be globally enabled for interrupt requests to be generated.

### Related Links

[10.2 Nested Vector Interrupt Controller](#)

#### 44.6.4 Events

The TRNG can generate the following output event:

- Data Ready (DATARDY): Generated when a new random number is available in the DATA register.

Writing '1' to the Data Ready Event Output bit in the Event Control Register (EVCTRL.DATARDYEO) enables the DTARDY event. Writing a '0' to this bit disables the corresponding output event. Refer to *EVSYS – Event System* for details on configuring the Event System.

### Related Links

[31. EVSYS – Event System](#)

#### 44.6.5 Sleep Mode Operation

The Run in Standby bit in Control A register (CTRLA.RUNSTDBY) controls the behavior of the TRNG during standby sleep mode:

When this bit is '0', the TRNG is disabled during sleep, but maintains its current configuration.

When this bit is '1', the TRNG continues to operate during sleep and any enabled TRNG interrupt source can wake up the CPU.

#### 44.6.6 Synchronization

Not applicable.

### 44.7 Register Summary

Offset	Name	Bit Pos.							
0x00	<a href="#">CTRLA</a>	7:0		RUNSTDBY					ENABLE
0x01	Reserved								
0x03									
0x04	<a href="#">EVCTRL</a>	7:0							DATARDYEO
0x05	Reserved								
0x07									
0x08	<a href="#">INTENCLR</a>	7:0							DATARDY
0x09	<a href="#">INTENSET</a>	7:0							DATARDY
0x0A	<a href="#">INTFLAG</a>	7:0							DATARDY
0x0B	Reserved								
0x1F									
0x20	<a href="#">DATA</a>	7:0	DATA[7:0]						
		15:8	DATA[15:8]						
		23:16	DATA[23:16]						
		31:24	DATA[31:24]						

### 44.8 Register Description

Registers can be 8, 16, or 32 bits wide. Atomic 8-, 16-, and 32-bit accesses are supported. In addition, the 8-bit quarters and 16-bit halves of a 32-bit register, and the 8-bit halves of a 16-bit register can be accessed directly.

Some registers require synchronization when read and/or written. Synchronization is denoted by the "Read-Synchronized" and/or "Write-Synchronized" property in each individual register description.

Optional write protection by the Peripheral Access Controller (PAC) is denoted by the "PAC Write Protection" property in each individual register description.

Some registers are enable-protected, meaning they can only be written when the module is disabled. Enable protection is denoted by the "Enable-Protected" property in each individual register description.

Refer to *PAC - Peripheral Access Controller* and [44.6.6 Synchronization](#) for details.

#### Related Links

[27. PAC - Peripheral Access Controller](#)

# SAM D5x/E5x Family Data Sheet

## TRNG – True Random Number Generator

### 44.8.1 Control A

**Name:** CTRLA  
**Offset:** 0x00  
**Reset:** 0x00  
**Property:** PAC Write-Protection

Bit	7	6	5	4	3	2	1	0
		RUNSTDBY					ENABLE	
Access		R/W					R/W	
Reset		0					0	

#### Bit 6 – RUNSTDBY Run in Standby

This bit controls how the TRNG behaves during standby sleep mode:

Value	Description
0	The TRNG is halted during standby sleep mode.
1	The TRNG is not stopped in standby sleep mode.

#### Bit 1 – ENABLE Enable

Value	Description
0	The TRNG is disabled.
1	The TRNG is enabled.

# SAM D5x/E5x Family Data Sheet

## TRNG – True Random Number Generator

### 44.8.2 Event Control

**Name:** EVCTRL  
**Offset:** 0x04  
**Reset:** 0x00  
**Property:** PAC Write-Protection, Enable-Protected

Bit	7	6	5	4	3	2	1	0
								DATARDYEO
Access								R/W
Reset								0

#### Bit 0 – DATARDYEO Data Ready Event Output

This bit indicates whether the Data Ready event output is enabled and whether an output event will be generated when a new random value is ready.

Value	Description
0	Data Ready event output is disabled and an event will not be generated.
1	Data Ready event output is enabled and an event will be generated.

### 44.8.3 Interrupt Enable Clear

**Name:** INTENCLR  
**Offset:** 0x08  
**Reset:** 0x00  
**Property:** PAC Write-Protection

This register allows the user to disable an interrupt without doing a read-modify-write operation. Changes in this register will also be reflected in the Interrupt Enable Set (INTENSET) register.

	7	6	5	4	3	2	1	0
								DATARDY
Access								R/W
Reset								0

**Bit 0 – DATARDY** Data Ready Interrupt Enable

Writing a '1' to this bit will clear the Data Ready Interrupt Enable bit, which disables the corresponding interrupt request.

Value	Description
0	The DATARDY interrupt is disabled.
1	The DATARDY interrupt is enabled.

# SAM D5x/E5x Family Data Sheet

## TRNG – True Random Number Generator

### 44.8.4 Interrupt Enable Set

**Name:** INTENSET  
**Offset:** 0x09  
**Reset:** 0x00  
**Property:** PAC Write-Protection

This register allows the user to enable an interrupt without doing a read-modify-write operation. Changes in this register will also be reflected in the Interrupt Enable Clear (INTENCLR) register.

Bit	7	6	5	4	3	2	1	0
								DATARDY
Access								R/W
Reset								0

#### Bit 0 – DATARDY Data Ready Interrupt Enable

Writing a '1' to this bit will set the Data Ready Interrupt Enable bit, which enables the corresponding interrupt request.

Value	Description
0	The DATARDY interrupt is disabled.
1	The DATARDY interrupt is enabled.

# SAM D5x/E5x Family Data Sheet

## TRNG – True Random Number Generator

### 44.8.5 Interrupt Flag Status and Clear

**Name:** INTFLAG  
**Offset:** 0x0A  
**Reset:** 0x00  
**Property:** -

Bit	7	6	5	4	3	2	1	0
								DATARDY
Access								R/W
Reset								0

#### **Bit 0 – DATARDY** Data Ready

This flag is set when a new random value is generated, and an interrupt will be generated if INTENCLR/SET.DATARDY=1.

This flag is cleared by writing a '1' to the flag or by reading the DATA register.

Writing a '0' to this bit has no effect.

# SAM D5x/E5x Family Data Sheet

## TRNG – True Random Number Generator

### 44.8.6 Output Data

**Name:** DATA  
**Offset:** 0x20  
**Reset:** 0x00000000  
**Property:** -

Bit	31	30	29	28	27	26	25	24
	DATA[31:24]							
Access	R/W	R/W	R/W	R/W	R/W	R/W	R/W	R/W
Reset	0	0	0	0	0	0	0	0
Bit	23	22	21	20	19	18	17	16
	DATA[23:16]							
Access	R/W	R/W	R/W	R/W	R/W	R/W	R/W	R/W
Reset	0	0	0	0	0	0	0	0
Bit	15	14	13	12	11	10	9	8
	DATA[15:8]							
Access	R/W	R/W	R/W	R/W	R/W	R/W	R/W	R/W
Reset	0	0	0	0	0	0	0	0
Bit	7	6	5	4	3	2	1	0
	DATA[7:0]							
Access	R/W	R/W	R/W	R/W	R/W	R/W	R/W	R/W
Reset	0	0	0	0	0	0	0	0

#### Bits 31:0 – DATA[31:0] Output Data

These bits hold the 32-bit randomly generated output data.



## 45. ADC – Analog-to-Digital Converter

### 45.1 Overview

The Analog-to-Digital Converter (ADC) converts analog signals to digital values. The ADC has up to 12-bit resolution, and is capable of a sampling rate of up to 1MSPS. The input selection is flexible, and both differential and single-ended measurements can be performed. In addition, several internal signal inputs are available. The ADC can provide both signed and unsigned results.

ADC measurements can be started by either application software or an incoming event from another peripheral in the device. ADC measurements can be started with predictable timing, and without software intervention.

Both internal and external reference voltages can be used.

An integrated temperature sensor is available for use with the ADC. The bandgap voltage, as well as the scaled I/O and core voltages, can also be measured by the ADC.

The ADC has a compare function for accurate monitoring of user-defined thresholds, with minimum software intervention required.

The ADC can be configured for 8-, 10- or 12-bit results. ADC conversion results are provided left- or right-adjusted, which eases calculation when the result is represented as a signed value. It is possible to use DMA to move ADC results directly to memory or peripherals when conversions are done.

The SAM D5x/E5x has two ADC instances, ADC0 and ADC1. The two inputs can be sampled simultaneously, as each ADC includes sample and hold circuits.

**Note:** When the Peripheral Touch Controller (PTC) is enabled, ADC0 is serving the PTC exclusively. In this case, ADC0 cannot be used by the user application.

### 45.2 Features

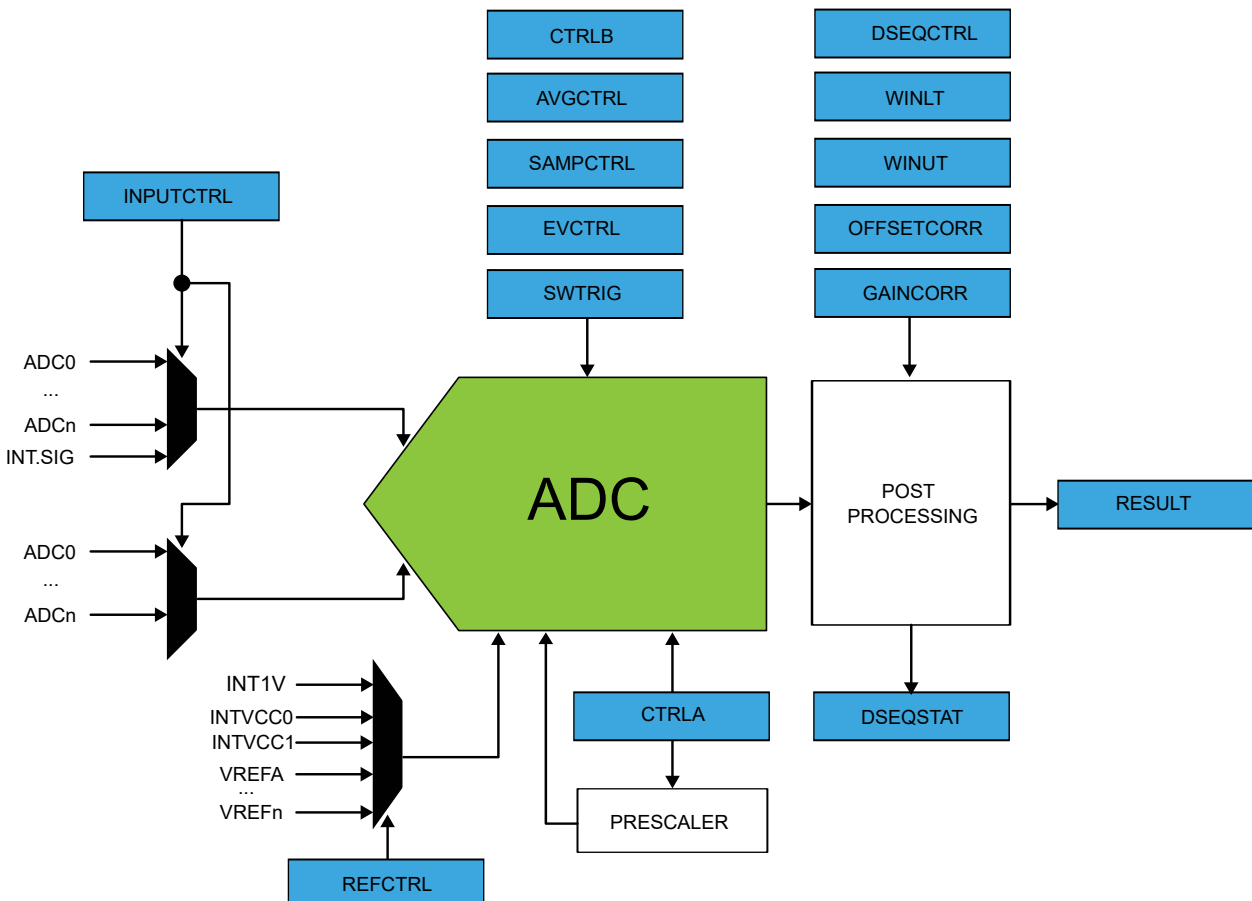
- Two Analog to Digital Converters (ADC) ADC0 and ADC1
- 8-, 10- or 12-bit resolution
- Up to 1,000,000 samples per second (1MSPS)
- Differential and single-ended inputs
  - Up to 32 analog inputs per ADC (20 unique channels total)  
32 positive and 10 negative, including internal and external
- Internal inputs:
  - Internal temperature sensor
  - Bandgap voltage
  - Scaled core supply
  - Scaled I/O supply
  - Scaled VBAT supply
  - DAC
- Single, continuous and sequencing options
- Windowing monitor with selectable channel
- Conversion range:  $V_{ref} = [1.0V \text{ to } VDD_{ANA}]$

- Built-in internal reference and external reference options
- Event-triggered conversion for accurate timing (one event input)
- Optional DMA transfer of conversion settings or result
- Hardware gain and offset compensation
- Averaging and oversampling with decimation to support up to 16-bit result
- Selectable sampling time
- Flexible Power / Throughput rate management

ADC0 can be configured to serve the Peripheral Touch Controller (PTC). Refer to the PTC chapter for details.

### 45.3 Block Diagram

Figure 45-1. ADC Block Diagram



### 45.4 Signal Description

Signal	Description	Type
VREF[A, B, C]	Analog input	External reference voltage
AIN[31..0]	Analog input	Analog input channels

**Note:** One signal can be mapped on several pins.

### Related Links

[6. I/O Multiplexing and Considerations](#)

## 45.5 Product Dependencies

In order to use this peripheral, other parts of the system must be configured correctly, as described below.

### 45.5.1 I/O Lines

Using the ADC's I/O lines requires the I/O pins to be configured using the port configuration (PORT).

### Related Links

[32. PORT - I/O Pin Controller](#)

### 45.5.2 Power Management

The ADC will continue to operate in any Sleep mode where the selected source clock is running. The ADC's interrupts, except the OVERRUN interrupt, can be used to wake up the device from Sleep modes, except the OVERRUN interrupt. Events connected to the event system can trigger other operations in the system without exiting Sleep modes.

### Related Links

[18. PM – Power Manager](#)

### 45.5.3 Clocks

The ADC bus clocks (CLK\_APB\_ADCx) can be enabled in the Main Clock, which also defines the default state.

Each ADC requires a generic clock (GCLK\_ADCx). This clock must be configured and enabled in the Generic Clock Controller (GCLK) before using the ADC.

A generic clock is asynchronous to the bus clock. Due to this asynchronicity, writes to certain registers will require synchronization between the clock domains. Refer to *Synchronization* for further details.

### Related Links

[15.6.2.6 Peripheral Clock Masking](#)

[14. GCLK - Generic Clock Controller](#)

### 45.5.4 DMA

The DMA request line is connected to the DMA Controller (DMAC). Using the ADC DMA requests requires the DMA Controller to be configured first.

### Related Links

[22. DMAC – Direct Memory Access Controller](#)

### 45.5.5 Interrupts

The interrupt request line is connected to the interrupt controller. Using the ADC interrupt requires the interrupt controller to be configured first.

### Related Links

[10.2 Nested Vector Interrupt Controller](#)

### 45.5.6 Events

The events are connected to the Event System.

#### Related Links

[31. EVSYS – Event System](#)

### 45.5.7 Debug Operation

When the CPU is halted in debug mode the ADC will halt normal operation. The ADC can be forced to continue operation during debugging. Refer to DBGCTRL register for details.

#### Related Links

[45.8.3 DBGCTRL](#)

### 45.5.8 Register Access Protection

All registers with write-access are optionally write-protected by the Peripheral Access Controller (PAC), except the following register:

- Interrupt Flag Status and Clear (INTFLAG) register

Optional write protection by the Peripheral Access Controller (PAC) is denoted by the "PAC Write Protection" property in each individual register description.

PAC write protection does not apply to accesses through an external debugger.

#### Related Links

[27. PAC - Peripheral Access Controller](#)

### 45.5.9 Analog Connections

I/O-pins (AINx), as well as the VREFA/VREFB/VREFC reference voltage pins are analog inputs to the ADC. Any internal reference source, such as a bandgap voltage reference, or DAC must be configured and enabled prior to its use with the ADC.

### 45.5.10 Calibration

The BIASREFBUF, BIASR2R and BIASCOMP calibration values from the production test must be loaded from the NVM Software Calibration Area into the ADC Calibration register (CALIB) by software to achieve specified accuracy.

## 45.6 Functional Description

### 45.6.1 Principle of Operation

By default, the ADC provides results with 12-bit resolution. 8-bit or 10-bit results can be selected in order to reduce the conversion time, see [45.6.2.8 Conversion Timing and Sampling Rate](#).

The ADC has an oversampling with decimation option that can extend the resolution to 16 bits. The input values can be either internal (e.g., an internal temperature sensor) or external (connected I/O pins). The user can also configure whether the conversion should be single-ended or differential.

### 45.6.2 Basic Operation

#### 45.6.2.1 Initialization

The following registers are enable-protected, meaning that they can only be written when the ADC is disabled (CTRLA.ENABLE=0):

- Control A (CTRLA), except ENABLE and SWRST bits
- Event Control register (EVCTRL)
- Calibration register (CALIB)

Enable-protection is denoted by the "Enable-Protected" property in the register description.

### 45.6.2.2 Enabling, Disabling, and Resetting

The ADC is enabled by writing a '1' to the Enable bit in the Control A register (CTRLA.ENABLE). The ADC is disabled by writing CTRLA.ENABLE=0.

The ADC is reset by writing a '1' to the Software Reset bit in the Control A register (CTRLA.SWRST). All registers in the ADC, except DBGCTRL, will be reset to their initial state, and the ADC will be disabled. Refer to [45.8.1 CTRLA](#) for details.

### 45.6.2.3 Operation

In the most basic configuration, the ADC samples values from the configured internal or external sources (INPUTCTRL register). The rate of the conversion depends on the combination of the GCLK\_ADCx frequency and the clock prescaler.

To convert analog values to digital values, the ADC needs to be initialized first, as described in the Initialization section. Data conversion can be started either manually by setting the Start bit in the Software Trigger register (SWTRIG.START=1), or automatically by configuring an automatic trigger to initiate the conversions. The ADC starts sampling the input only after the start of conversion is triggered. This means that even after the MUX selection is made, sample and hold (S&H) operation starts only on the conversion trigger. A free-running mode can be used to continuously convert an input channel. When using free-running mode the first conversion must be started, while subsequent conversions will start automatically at the end of previous conversions.

The ADC starts sampling the input only after the start of a conversion is triggered. This means that even after the MUX selection is made, sample and hold operation starts only on the conversion trigger.

The result of the conversion is stored in the Result register (RESULT) overwriting the result from the previous conversion.

To avoid data loss, if more than one channel is enabled, the conversion result must be read as soon as it is available (INTFLAG.RESRDY). Failing to do so will result in an overrun error condition, indicated by the OVERRUN bit in the Interrupt Flag Status and Clear register (INTFLAG.OVERRUN).

To enable one of the available interrupts sources, the corresponding bit in the Interrupt Enable Set register (INTENSET) must be written to '1'.

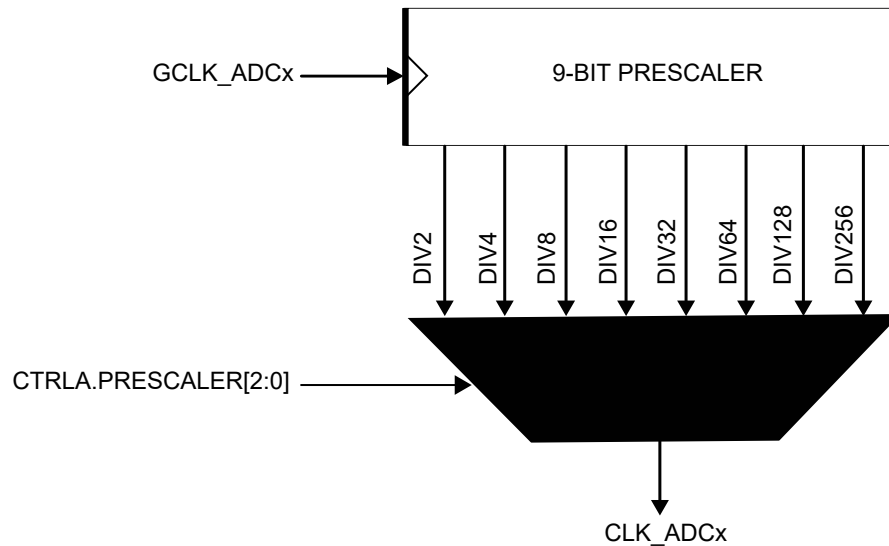
#### Related Links

[45.6.2.1 Initialization](#)

### 45.6.2.4 Prescaler Selection

The ADC is clocked by GCLK\_ADCx. There is also a prescaler in the ADC to enable conversion at lower clock rates. Refer to CTRLA for details on prescaler settings. Refer to [45.6.2.8 Conversion Timing and Sampling Rate](#) for details on timing and sampling rate.

**Figure 45-2. ADC Prescaler**



**Note:** The minimum prescaling factor is DIV2.

#### 45.6.2.5 Reference Configuration

The ADC has various sources for its reference voltage  $V_{REF}$ . The Reference Voltage Selection bit field in the Reference Control register (REFCTRL.REFSEL) determines which reference is selected. By default, the internal voltage reference  $V_{REF}$  is selected. Based on customer application requirements, the external or internal reference can be selected. Refer to REFCTRL.REFSEL for further details on available selections.

#### Related Links

[45.8.6 REFCTRL](#)

#### 45.6.2.6 ADC Resolution

The ADC supports 8-bit, 10-bit or 12-bit resolution. Resolution can be changed by writing the Resolution bit group in the Control B register (CTRLB.RESSEL). By default, the ADC resolution is set to 12 bits. The resolution affects the propagation delay, see also [45.6.2.8 Conversion Timing and Sampling Rate](#).

#### 45.6.2.7 Differential and Single-Ended Conversions

The ADC has two conversion options: differential and single-ended.

If the positive input is always positive, the single-ended conversion should be used in order to have full 12-bit resolution in the conversion.

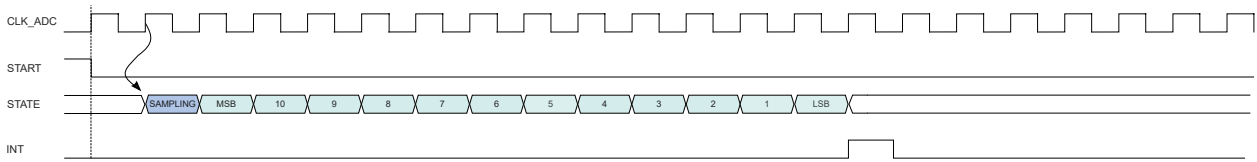
If the positive input level may go below the negative input, the differential mode should be used in order to get correct results.

The differential mode is enabled by writing a '1' to the DIFFMODE bit in the input control register (INPUTCTRL.DIFFMODE). Both conversion types could be run in single mode or in free-running mode. When the free-running mode is selected, an ADC input will continuously sample the input and performs a new conversion. The INTFLAG.RESRDY bit will be set at the end of each conversion.

#### 45.6.2.8 Conversion Timing and Sampling Rate

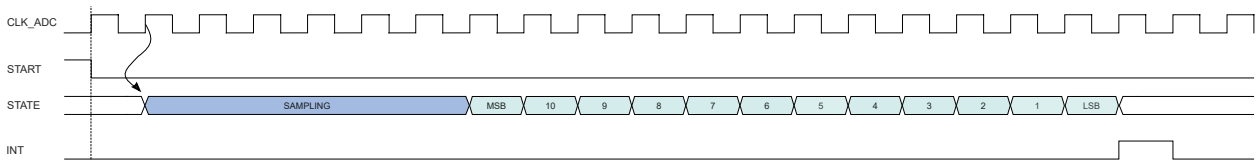
The following figure shows the ADC timing for one single conversion. A conversion starts after the software or event start are synchronized with the GCLK\_ADCx clock. The input channel is sampled in the first half CLK\_ADCx period.

**Figure 45-3. ADC Timing for One Conversion in 12-bit Resolution**



The sampling time can be increased by using the Sampling Time Length bit group in the Sampling Time Control register (SAMPCTRL.SAMPLEN). As example, the next figure is showing the timing conversion with sampling time increased to six CLK\_ADC cycles.

**Figure 45-4. ADC Timing for One Conversion with Increased Sampling Time, 12-bit**



The ADC provides also offset compensation, see the following figure. The offset compensation is enabled by the Offset Compensation bit in the Sampling Control register (SAMPCTRL.OFFCOMP).

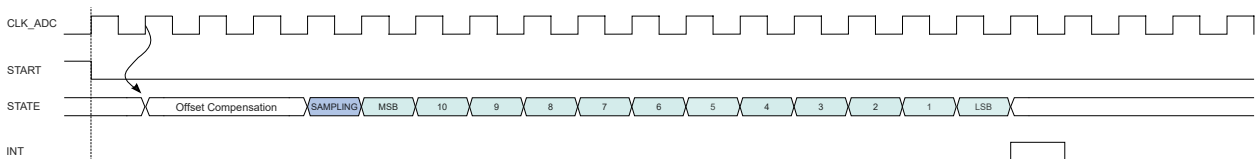
**Note:** If offset compensation is used, the sampling time must be set to one cycle of CLK\_ADCx.

In free running mode, the sampling rate  $R_S$  is calculated by

$$R_S = f_{CLK\_ADC} / (n_{SAMPLING} + n_{OFFCOMP} + n_{DATA})$$

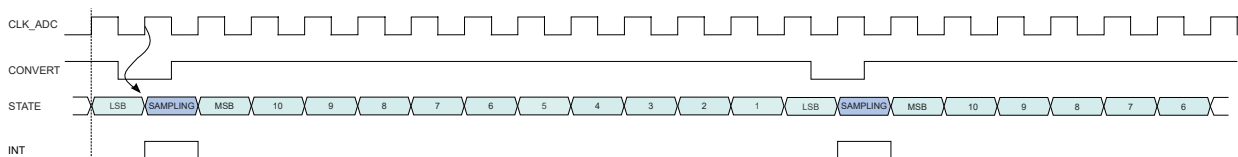
Here,  $n_{SAMPLING}$  is the sampling duration in CLK\_ADC cycles,  $n_{OFFCOMP}$  is the offset compensation duration in clock cycles, and  $n_{DATA}$  is the bit resolution.  $f_{CLK\_ADC}$  is the ADC clock frequency from the internal prescaler:  $f_{CLK\_ADC} = f_{GCLK\_ADC} / 2^{(1 + CTRLA.PRESCALER)}$

**Figure 45-5. ADC Timing for One Conversion with Offset Compensation, 12-bit**



The impact of resolution on the sampling rate is seen in the next two figures, where free-running sampling in 12-bit and 8-bit resolution are compared.

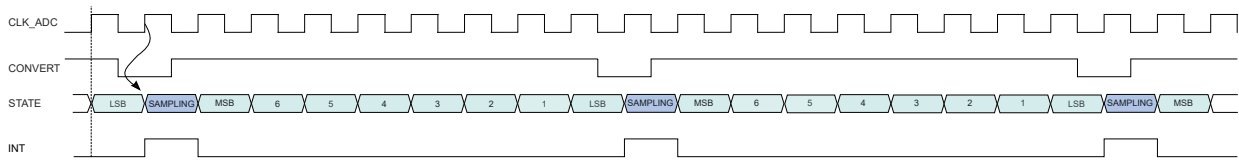
**Figure 45-6. ADC Timing for Free Running in 12-bit Resolution**



# SAM D5x/E5x Family Data Sheet

## ADC – Analog-to-Digital Converter

**Figure 45-7. ADC Timing for Free Running in 8-bit Resolution**



The propagation delay of an ADC measurement is given by:

$$\text{PropagationDelay} = \frac{1 + \text{Resolution}}{f_{\text{ADC}}}$$

**Example.** In order to obtain 1MSPS in 12-bit resolution with a sampling time length of four CLK\_ADC cycles,  $f_{\text{CLK\_ADC}}$  must be  $1\text{MSPS} * (4 + 12) = 16\text{MHz}$ . As the minimal division factor of the prescaler is 2, GCLK\_ADC must be 32MHz.

### 45.6.2.9 Accumulation

The results of multiple, consecutive conversions can be accumulated. The number of samples to be accumulated is specified by the Sample Number field in the Average Control register (AVGCTRL.SAMPLENUM). When accumulating more than 16 samples, the result will be too large to fit the 16-bit RESULT register size. To avoid overflow, the result is right shifted automatically to fit within the available register size. The number of automatic right shifts is specified in the table below.

**Note:** To perform the accumulation of two or more samples, the Conversion Result Resolution field in the Control B register (CTRLB.RESSEL) must be set.

**Table 45-1. Accumulation**

Number of Accumulated Samples	AVGCTRL.SAMPLENUM	Number of Automatic Right Shifts	Final Result Precision	Automatic Division Factor
1	0x0	0	12 bits	0
2	0x1	0	13 bits	0
4	0x2	0	14 bits	0
8	0x3	0	15 bits	0
16	0x4	0	16 bits	0
32	0x5	1	16 bits	2
64	0x6	2	16 bits	4
128	0x7	3	16 bits	8
256	0x8	4	16 bits	16
512	0x9	5	16 bits	32
1024	0xA	6	16 bits	64
Reserved	0xB –0xF		12 bits	0



# SAM D5x/E5x Family Data Sheet

## ADC – Analog-to-Digital Converter

**Table 45-2. Accumulation**

Number of Accumulated Samples	AVGCTRL.SAMPLENUM	Intermediate Result Precision	Number of Automatic Right Shifts	Final Result Precision	Automatic Division Factor
1	0x0	12 bits	0	12 bits	0
2	0x1	13 bits	0	13 bits	0
4	0x2	14 bits	0	14 bits	0
8	0x3	15 bits	0	15 bits	0
16	0x4	16 bits	0	16 bits	0
32	0x5	17 bits	1	16 bits	2
64	0x6	18 bits	2	16 bits	4
128	0x7	19 bits	3	16 bits	8
256	0x8	20 bits	4	16 bits	16
512	0x9	21 bits	5	16 bits	32
1024	0xA	22 bits	6	16 bits	64
Reserved	0xB –0xF	12 bits		12 bits	0

### 45.6.2.10 Averaging

Averaging is a feature that increases the sample accuracy, at the cost of a reduced sampling rate. This feature is suitable when operating in noisy conditions.

Averaging is done by accumulating *m* samples, as described in [45.6.2.9 Accumulation](#), and dividing the result by *m*. The averaged result is available in the RESULT register. The number of samples to be accumulated is specified by writing to AVGCTRL.SAMPLENUM as shown in [Table 45-3](#).

The division is obtained by a combination of the automatic right shift described above, and an additional right shift that must be specified by writing to the Adjusting Result/Division Coefficient field in AVGCTRL (AVGCTRL.ADJRES), as described in [Table 45-3](#).

**Note:** To perform the averaging of two or more samples, the Conversion Result Resolution field in the Control B register (CTRLB.RESSEL) must be set.

Averaging AVGCTRL.SAMPLENUM samples will reduce the un-averaged sampling rate by a factor  $\frac{1}{\text{AVGCTRL.SAMPLENUM}}$ .

When the averaged result is available, the INTFLAG.RESRDY bit will be set.

**Table 45-3. Averaging**

Number of Accumulated Samples	AVGCTRL.SAMPLENUM	Intermediate Result Precision	Number of Automatic Right Shifts	Division Factor	AVGCTRL.ADJRES	Total Number of Right Shifts	Final Result Precision	Automatic Division Factor
1	0x0	12 bits	0	1	0x0		12 bits	0
2	0x1	13	0	2	0x1	1	12 bits	0
4	0x2	14	0	4	0x2	2	12 bits	0

# SAM D5x/E5x Family Data Sheet

## ADC – Analog-to-Digital Converter

.....continued

Number of Accumulated Samples	AVGCTRL.SAMPLENUM	Intermediate Result Precision	Number of Automatic Right Shifts	Division Factor	AVGCTRL.ADJRES	Total Number of Right Shifts	Final Result Precision	Automatic Division Factor
8	0x3	15	0	8	0x3	3	12 bits	0
16	0x4	16	0	16	0x4	4	12 bits	0
32	0x5	17	1	16	0x4	5	12 bits	2
64	0x6	18	2	16	0x4	6	12 bits	4
128	0x7	19	3	16	0x4	7	12 bits	8
256	0x8	20	4	16	0x4	8	12 bits	16
512	0x9	21	5	16	0x4	9	12 bits	32
1024	0xA	22	6	16	0x4	10	12 bits	64
Reserved	0xB–0xF				0x0		12 bits	0

### 45.6.2.11 Oversampling and Decimation

By using oversampling and decimation, the ADC resolution can be increased from 12 bits up to 16 bits, for the cost of reduced effective sampling rate.

To increase the resolution by  $n$  bits,  $4^n$  samples must be accumulated. The result must then be right shifted by  $n$  bits. This right shift is a combination of the automatic right shift and the value written to AVGCTRL.ADJRES. To obtain the correct resolution, the ADJRES must be configured as described in the table below. This method will result in  $n$  bit extra LSB resolution.

**Table 45-4. Configuration Required for Oversampling and Decimation**

Result Resolution	Number of Samples to Average	AVGCTRL.SAMPLENUM[3:0]	Number of Automatic Right Shifts	AVGCTRL.ADJRES[2:0]
13 bits	$4^1 = 4$	0x2	0	0x1
14 bits	$4^2 = 16$	0x4	0	0x2
15 bits	$4^3 = 64$	0x6	2	0x1
16 bits	$4^4 = 256$	0x8	4	0x0

### 45.6.2.12 Window Monitor

The window monitor feature allows comparing the conversion result in the RESULT register to predefined threshold values.

The window mode is selected by writing the Window Monitor Mode bits in the Control B register (CTRLB.WINMODE). Threshold values must be written in the Window Monitor Lower Threshold register (WINLT) and Window Monitor Upper Threshold register (WINUT).

When the Window Single Sample (CTRLB.WINSS) bit is written to '1', the window comparator is working on each sample instead of the accumulated value. The number of samples matching with window comparator is available on Window Comparator Counter bits (STATUS.WCC).

In differential mode, WINLT and WINUT are evaluated as signed values. Otherwise they are evaluated as unsigned values. The significant WINLT and WINUT bits are given by the precision selected in the Conversion Result Resolution bit group in the Control B register (CTRLB.RESSEL). This means that for

example in 8-bit mode, only the eight lower bits will be considered. In addition, in differential mode, the eighth bit will be considered as the sign bit, even if the ninth bit is zero.

The INTFLAG.WINMON interrupt flag is set when either the conversion result matches the window monitor condition, when the Window Comparator Counter is not zero in case of accumulation with CTRLB.WINSS=1.

### 45.6.2.13 Offset and Gain Correction

Inherent gain and offset errors affect the absolute accuracy of the ADC.

The offset error is defined as the deviation of the actual ADC transfer function from an ideal straight line at zero input voltage. The offset error cancellation is handled by the Offset Correction register (OFFSETCORR). The offset correction value is subtracted from the converted data before writing the Result register (RESULT).

The gain error is defined as the deviation of the last output step's midpoint from the ideal straight line, after compensating for offset error. The gain error cancellation is handled by the Gain Correction register (GAINCORR).

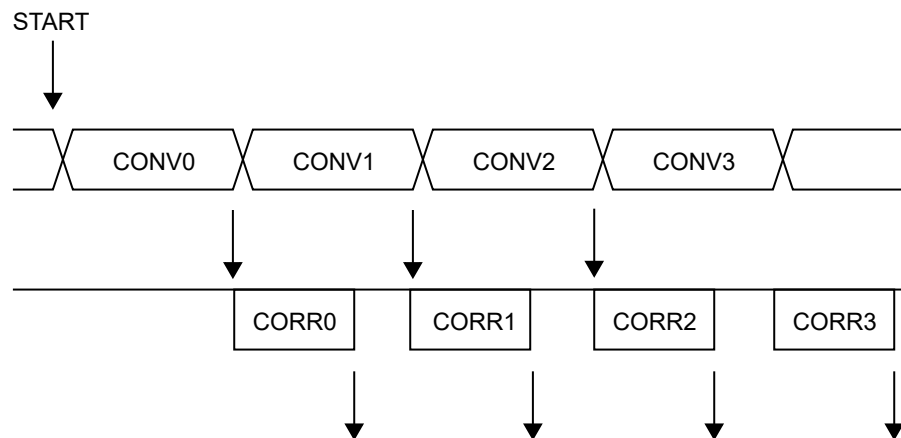
To correct these two errors, the Digital Correction Logic Enabled bit in the Control B register (CTRLB.CORREN) must be set.

Offset and gain error compensation results are both calculated according to:

$$\text{Result} = (\text{Conversion value} + \text{OFFSETCORR}) \cdot \text{GAINCORR}$$

The correction will introduce a latency of 13 CLK\_ADC clock cycles. In free running mode this latency is introduced on the first conversion only, since its duration is always less than the propagation delay. In single conversion mode this latency is introduced for each conversion.

**Figure 45-8. ADC Timing Correction Enabled**



### 45.6.3 Additional Features

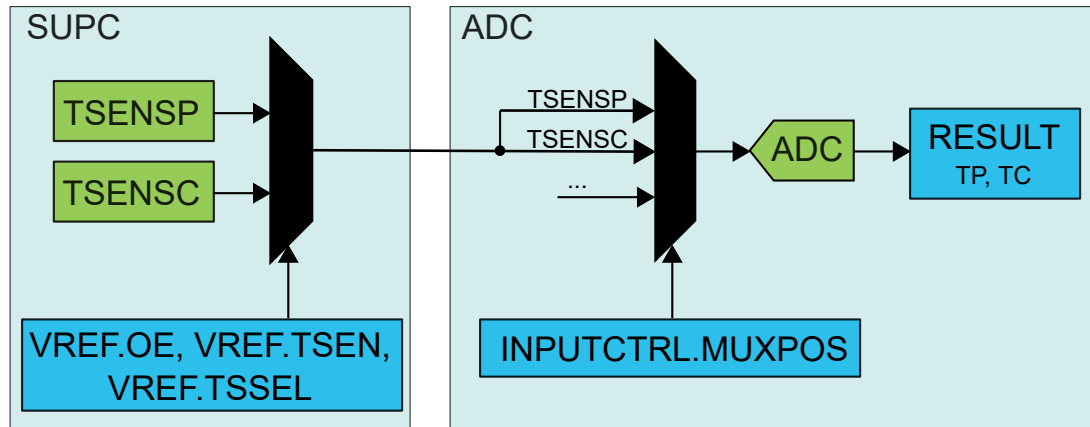
#### 45.6.3.1 Device Temperature Measurement

The device provides two temperature sensors (TSENSP and TSENSC, respectively) at different locations in the die, controlled by the SUPC - Supply Controller. The output voltages from the sensors,  $V_{TP}$  and  $V_{TC}$ , can be sampled by the ADC.

The respective temperature sensor selection is dependent on the configuration of SUPC:

- If the SUPC is not in on-demand mode (SUPC.VREF.ONDEMAND=0), and if SUPC.VREF.TSEN=1 and SUPC.VREF.VREFOE=0, the temperature sensor is selected by writing to the Temperature

Sensor Channel Selection bit in the Voltage Reference System Control register (SUPC.VREF.TSSEL).



The state of the MUX input selection bit fields in the ADC Input Control register (ADC.INPUTCTRL.MUXPOS and MUXNEG) does not affect the sensor selection.

- If the SUPC is in on-demand mode in (SUPC.VREF.ONDEMAND=1) and SUPC.VREF.TSEN=1, the output will be automatically set to the sensor requested by the ADC, independent of SUPC.VREF.TSSEL. SUPC.VREF.VREFOE can also be set to '1'.

Which temperature sensor is requested by the ADC is selected by writing to the Positive MUX Input Selection bits in the Input Control register (ADC.INPUTCTRL.MUXPOS).

Using the two conversion results, TP and TC, and the temperature calibration parameters found in the NVM Software Calibration Area, the die temperature  $T$  can be calculated:

$$T = \frac{TL \cdot VPH \cdot TC - VPL \cdot TH \cdot TC - TL \cdot VCH \cdot TP + TH \cdot VCL \cdot TP}{VCL \cdot TP - VCH \cdot TP - VPL \cdot TC + VPH \cdot TC}$$

Here, TL and TH are decimal numbers composed of their respective integer part (TLI, THI) and decimal parts (TLD and THD) from the NVM Software Calibration Area.

**Note:** The accuracy is dependent on the current temperature, and degrades towards extreme conditions.

### Related Links

[19. SUPC – Supply Controller](#)

#### 45.6.3.2 Double Buffering

The following registers are double buffered:

- Input Control (INPUTCTRL)
- Control B (CTRLB)
- Reference Control (REFCTRL)
- Average Control (AVGCTRL)
- Sampling Time Control (SAMPCTRL)
- Window Monitor Lower Threshold (WINLT)
- Window Monitor Upper Threshold (WINUT)
- Gain Correction (GAINCORR)
- Offset Correction (OFFSETCORR)

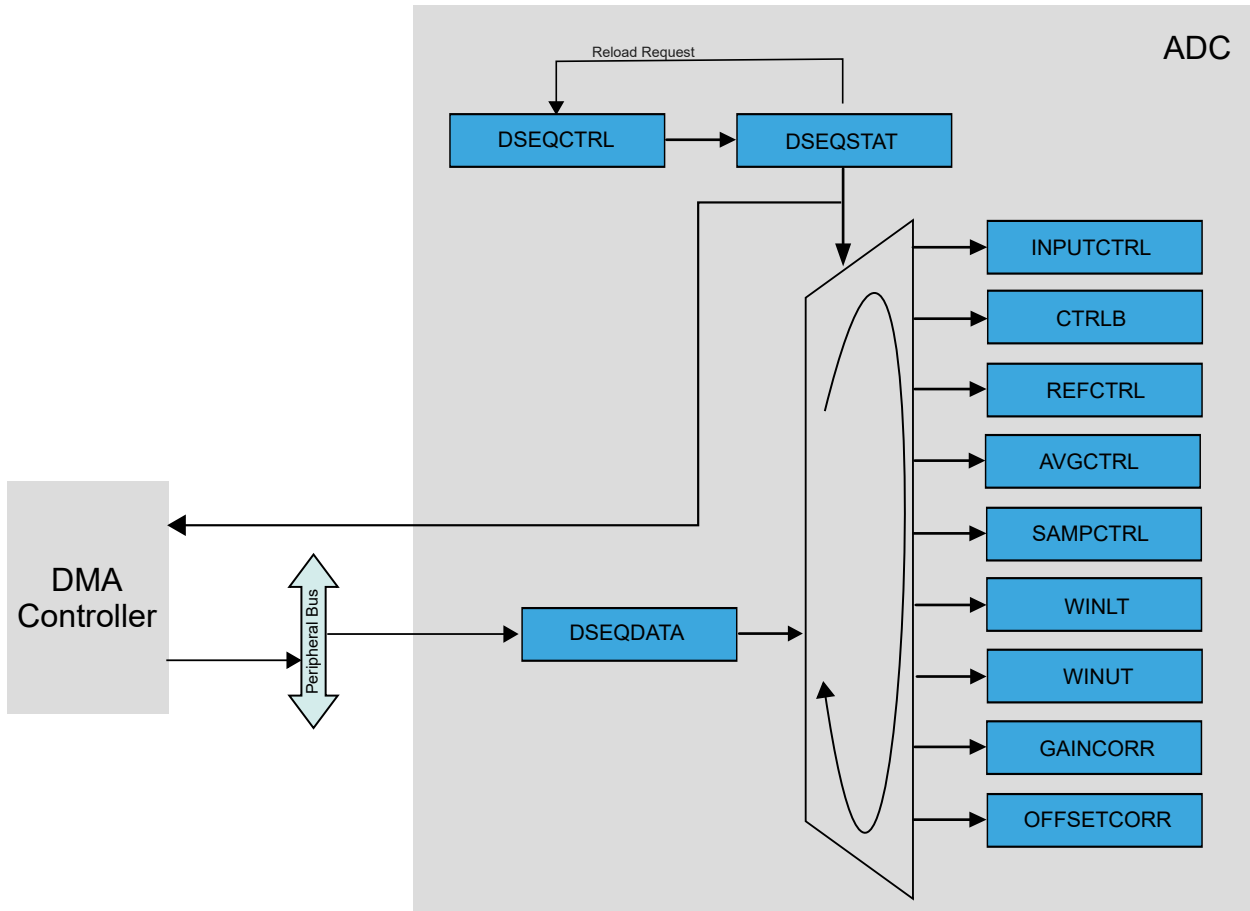
# SAM D5x/E5x Family Data Sheet

## ADC – Analog-to-Digital Converter

When one of these registers is written, the data is stored in the corresponding buffer as long as the current conversion is not impacted, and the corresponding busy status will be set in the Synchronization Busy register (SYNCBUSY). When a new RESULT is available, data stored in the buffer registers will be transferred to the ADC and a new conversion can start.

### 45.6.3.3 DMA Sequencing

The ADC can sequence a series of conversion. When DMA sequencing is enabled, a set of ADC configuration registers can be automatically refreshed using the DMA controller.



#### Enabling DMA Sequencing

DMA Sequencing is enabled when at least one bit in the DMA Sequence Control register (DSEQCTRL) is '1'.

When this is the case, the BUSY status bit in the DMA Sequential Status register (DSEQSTAT.BUSY) is set to '1'.

#### Disabling DMA Sequencing

DMA Sequencing is disabled when at least one of the following conditions is valid:

- The ADC is disabled (CTRLA.ENABLE = 0).
- The ADC is reset (CTRLA.SWRST = 1).
- The DMA Sequence Control register (DSEQCTRL) is written '0' and the ongoing DMA sequence is completed.

# SAM D5x/E5x Family Data Sheet

## ADC – Analog-to-Digital Converter

- The DMA Sequencing Stop bit in Input Control register is '1' (INPUTCTRL.DSEQSTOP = 1) and the ongoing DMA sequence is complete. One additional measurement will be done before the ADC is disabled.

When the DMA sequencing is disabled, the BUSY status bit in the DMA Sequential Status register (DSEQSTAT.BUSY) is cleared and the DMA trigger generation is disabled.

Note that if the DSEQCTRL register is written to a non-zero value, the DSEQSTOP bit in the INPUTCTRL register will be cleared and the sequencing operation will not be stopped.

### Restarting DMA Sequencing

When the DSEQSTOP bit is set (INPUTCTRL.DSEQSTOP = 1) and the sequence is disabled (DSEQSTAT.BUSY=0), it is possible to restart the sequencing by enabling one of the following conditions:

- Write the DSEQSTOP bit in Input Control register to zero (INPUTCTRL.DSEQSTOP = 0)
- Apply a FLUSH software command (SWTRIG.FLUSH = 1)
- Enable the flush event (EVCTRL.FLUSHEI). The sequence will restart when the flush event is received

### DMA Sequencing Operation

Each ADC register that is part of the DMA sequencing has a separate enable bit in the DSEQCTRL register to indicate that this field should be part of the DMA sequencing. When an enable bit in DSEQCTRL is '1', the respective register will be updated when an access to DSEQDATA is decoded.

The DMA Sequencing (DSEQ) trigger request is generated when BUSY status bit is one (DSEQSTAT.BUSY=1), the ADC is idle or a new conversion starts, and one of the following condition is true:

- Input Control or Control B bits in DMA Sequential Control register is '1' (DSEQCTRL.INPUTCTRL=1 or DSEQCTRL.CTRLB=1)
- Reference Control, Sampling Time Control or Average Control bits in DMA Sequential Control register is set (DSEQCTRL.REFCTRL=1, DSEQCTRL.AVGCTRL=1 or DSEQCTRL.SAMPCTRL=1)
- Window Monitor Upper Threshold or Window Monitor Lower Threshold bits in DMA Sequential Control register is set (DSEQCTRL.WINUT=1 or DSEQCTRL.WINLT=1)
- Offset Correction or Gain Correction bits in DMA Sequential Control register is set (DSEQCTRL.GAINCORR=1 or DSEQCTRL.OFFSETCORR=1)

**Note:** When received, the DMA data must be written to DSEQDATA register only, and only 32-bit DMA access is supported.

If a field is not enabled for DMA update, the corresponding register update will be ignored when DSEQDATA register is written. The table below shows the DSEQ trigger generation condition and internal ADC registers refresh when the DSEQDATA register is written by the DMA.

# SAM D5x/E5x Family Data Sheet

## ADC – Analog-to-Digital Converter

**Table 45-5. DSEQ Trigger Generation and Internal ADC Register updates**

Condition	Value	Action when DMA writes to DSEQDATA
DSEQSTAT.INPUTCTRL or DSEQSTAT.CTRLB	0	<ul style="list-style-type: none"> <li>No DMA trigger is generated</li> <li>No data in the memory must be reserved</li> </ul>
	1	<ul style="list-style-type: none"> <li>A DMA trigger is generated</li> <li>One word (32-bit) must be reserved in the memory</li> <li>INPUTCTRL ← DSEQDATA[15:0] if DSEQSTAT.INPUTCTRL = 1</li> <li>CTRLB ← DSEQDATA[31:16] if DSEQSTAT.CTRLB = 1</li> </ul>
DSEQSTAT.REFCTRL or DSEQSTAT.AVGCTRL or DSEQSTAT.SAMPCTRL	0	<ul style="list-style-type: none"> <li>No DMA trigger is generated</li> <li>No data in the memory must be reserved</li> </ul>
	1	<ul style="list-style-type: none"> <li>A DMA trigger is generated</li> <li>One word (32-bit) must be reserved in the memory</li> <li>REFCTRL ← DSEQDATA[7:0] if DSEQSTAT.REFCTRL = 1</li> <li>AVGCTRL ← DSEQDATA[23:16] if DSEQSTAT.AVGCTRL = 1</li> <li>SAMPCTRL ← DSEQDATA[31:24] if DSEQSTAT.SAMPCTRL = 1</li> </ul>
DSEQSTAT.WINLT or DSEQSTAT.WINUT	0	<ul style="list-style-type: none"> <li>No DMA trigger is generated</li> <li>No data in the memory must be reserved</li> </ul>
	1	<ul style="list-style-type: none"> <li>A DMA trigger is generated</li> <li>One word (32-bit) must be reserved in the memory</li> <li>WINLT ← DSEQDATA[15:0] if DSEQSTAT.WINLT = 1</li> <li>WINUT ← DSEQDATA[31:16] if DSEQSTAT.WINUT = 1</li> </ul>
DSEQSTAT.GAINCORR or DSEQSTAT.OFFSETCORR	0	<ul style="list-style-type: none"> <li>No DMA trigger is generated</li> <li>No data in the memory must be reserved</li> </ul>
	1	<ul style="list-style-type: none"> <li>A DMA trigger is generated</li> <li>One word (32-bit) must be reserved in the memory</li> <li>GAINCORR ← DSEQDATA[15:0] if DSEQSTAT.GAINCORR = 1</li> <li>OFFSETCORR ← DSEQDATA[31:16] if DSEQSTAT.OFFSETCORR = 1</li> </ul>

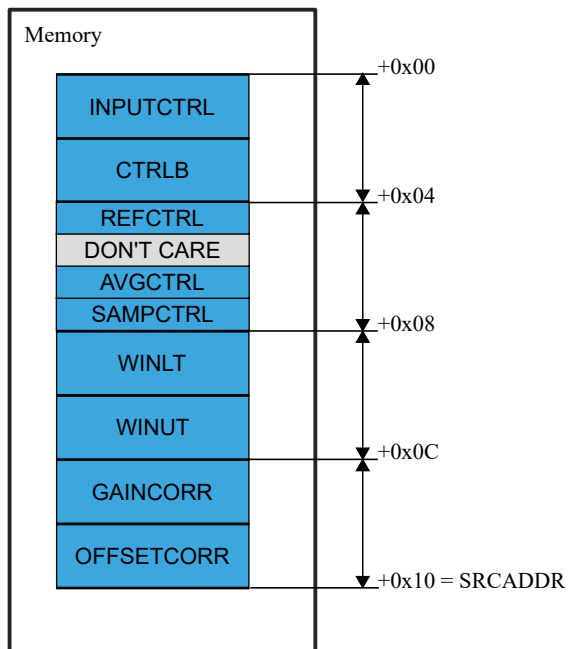
The DMA Sequential Status register (DSEQSTAT) stores the remaining registers to be updated by the DMA. During a sequence and when a write access to the DSEQDATA register is detected, the DSEQSTAT bits which were source of the corresponding DSEQ trigger will be cleared. When all DSEQSTAT bits are zero (except BUSY bit), the DSEQCTRL register bits (except AUTOSTART) are copied into the DSEQSTAT register and a new DMA sequence is started when a new ADC conversion starts.

### DMA Descriptor Setup and Data Memory Organization

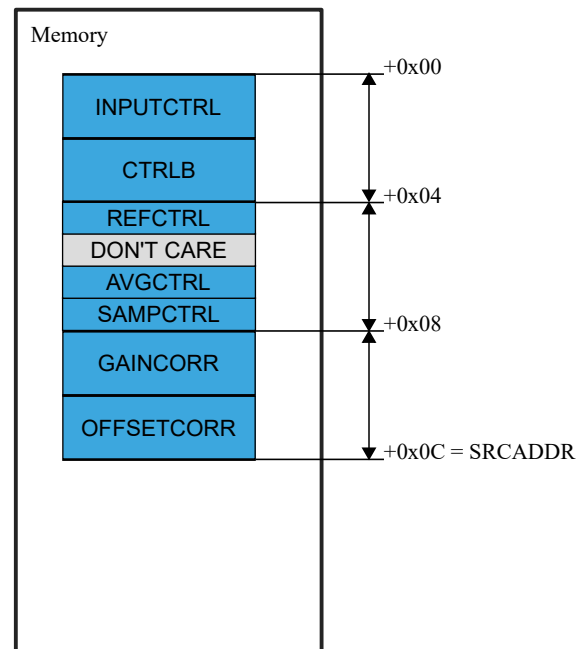
When DMA sequencing is enabled, the DMA Controller (DMAC) must be configured in the following way:

- Select 32-bit beat size transfer (DMAC.BTCTRL.BEATSIZE=WORD).
- Enable the source address increment options (DMAC.BTCTRL.SRCINC = 1, DMAC.BTCTRL.STEPSEL = SRC, DMAC.BTCTRL.STEPSIZE = X1).
- Disable the destination address increment (DMAC.BTCTRL.DSTINC=0).
- Set the block transfer count value (DMAC.BTCNT).
- Set the block transfer source address (DMAC.SRCADDR), as described in the DMAC Addressing section. The address corresponds to the memory section from where the DMA reads the data.
- Select the ADC.DSEQDATA address as value for the block transfer destination address (DMAC.DSTADDR = ADC.DSEQDATA address).
- Select the channel single transfer type (DMAC.CHCTRLA.BURSTLEN=SINGLE)
- Select the channel burst trigger action (DMAC.CHCTRLA.TRIGACT=BURST)
- Select the ADC DMA Sequencing trigger as channel trigger source (DMAC.CHCTRLA.TRIGSRC=DSEQ)
- Enable optional channel interrupts (DMAC.CHINTENSET)
- Enable the corresponding DMA channel (DMAC.CHCTRLA.ENABLE)

When an ADC condition is enabled to trigger a DMA transfer, one word (32-bit) will be read by the DMA from the memory source location. Since the source address is incrementing by 0x1, the data memory must be organized in a contiguous memory area. As consequence, if an ADC group of registers does not generate any DMA trigger, no data must be reserved in the memory area for this register group. The next figure shows an example of memory organization when all ADC registers are part of the sequence, and a second example where WINLT and WINUT registers are not part of the sequence.



All registers are in the sequence



WINLT / WINUT registers are not in the sequence

### Automatic Start Conversion



# SAM D5x/E5x Family Data Sheet

## ADC – Analog-to-Digital Converter

---

By default, a new conversion starts when a new start software or event trigger is received. It is also possible to automatically enable an ADC conversion by writing '1' to the AUTOSTART bit in DSEQCTRL register (DSEQCTRL.AUTOSTART). When set, the ADC automatically starts a new conversion when a DMA sequence is complete.

**Note:** If averaging or oversampling is enabled, the new conversion automatically starts only when the previous RESULT is available (averaging or oversampling operation is complete).

**Note:** If the free-run mode is enabled (CTRLB.FREERUN=1), the new conversion automatically starts when the previous RESULT is available and the DMA sequence is complete. As consequence, the AUTOSTART bit has no effect in free-run operating mode.

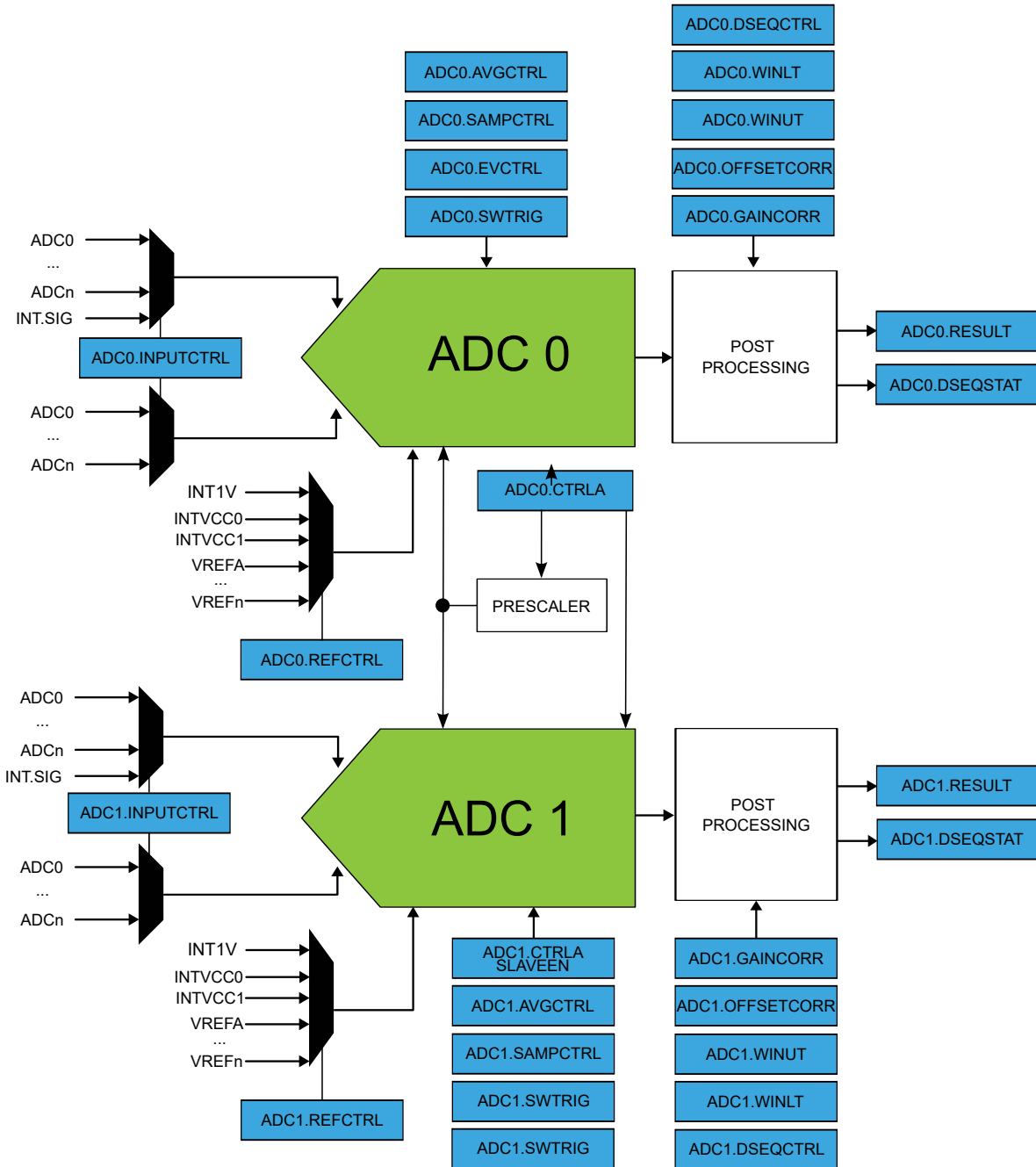
**Note:** If the conversion is triggered by event (EVCTRL.STARTEI=1), the automatic start conversion is disabled and the AUTOSTART settings are ignored.

### Related Links

[22.6.2.7 Addressing](#)

#### 45.6.3.4 Master - Slave Operation

ADC1 will serve as a slave of ADC0 by writing a '1' to the Slave Enable bit in the Control A register of the ADC1 instance (ADC1.CTRLA.SLAVEEN). When enabled, GCLK\_ADC0 clock and ADC0 controls are internally routed to the ADC1 instance.



In this mode of operation, the slave ADC1 is enabled by accessing the CTRLA register of the master ADC0. In the same way, the master ADC event inputs will be automatically routed to the slave ADC, meaning that the input events configuration must be done in the master ADC (ADC0.EVCTRL).

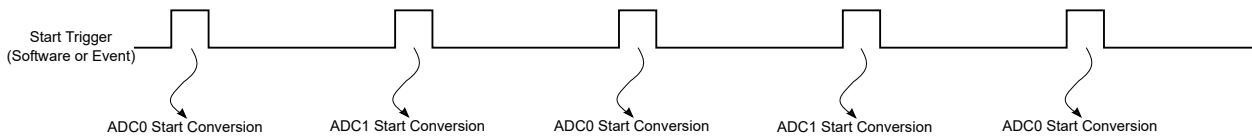
ADC measurements can either start simultaneously on both ADCs, or be interleaved. The trigger mode selection is available in the master ADC Control A register (ADC0.CTRLA.DUALSEL).

**Note:** The interleaved sampling is only usable in single conversion mode (ADC.CTRLB.FREERUN=0).

To restart an interleaved sequence, the user can apply different options:

- Flush the master ADC (ADC0.SWTRIG.FLUSH = 1)
- Disable/re-enable the master ADC (ADC0.CTRLA.ENABLE)

- Reset and reconfigure master ADC (ADC0.CTRLA.SWRST = 1)
- Enable the flush event (EVCTRL.FLUSHEI = 1)



### 45.6.4 DMA Operation

The ADC generates the following DMA request:

- Result Conversion Ready (RESRDY): the request is set when a conversion result is available and cleared when the RESULT register is read. When the averaging operation is enabled, the DMA request is set when the averaging is completed and result is available.
- DMA Sequencing (DSEQ): for details refer to "add link to DMA sequencing"

### 45.6.5 Interrupts

The ADC has the following interrupt sources:

- Result Conversion Ready: RESRDY
- Window Monitor: WINMON
- Overrun: OVERRUN

These interrupts, except the OVERRUN interrupt, are asynchronous wake-up sources. See *Sleep Mode Controller* for details.

Each interrupt source has an interrupt flag associated with it. The interrupt flag in the Interrupt Flag Status and Clear (INTFLAG) register is set when the interrupt condition occurs. Each interrupt can be individually enabled by writing a one to the corresponding bit in the Interrupt Enable Set (INTENSET) register, and disabled by writing a one to the corresponding bit in the Interrupt Enable Clear (INTENCLR) register. An interrupt request is generated when the interrupt flag is set and the corresponding interrupt is enabled. The interrupt request remains active until the interrupt flag is cleared, the interrupt is disabled, or the ADC is reset. See INTFLAG register for details on how to clear interrupt flags. All interrupt requests from the peripheral are ORed together on system level to generate one combined interrupt request to the NVIC. Refer to *Nested Vector Interrupt Controller* for details. The user must read the INTFLAG register to determine which interrupt condition is present.

Note that interrupts must be globally enabled for interrupt requests to be generated. Refer to *Nested Vector Interrupt Controller* for details.

#### Related Links

[45.8.16 INTFLAG](#)

### 45.6.6 Events

The ADC can generate the following output events:

- Result Ready (RESRDY): Generated when the conversion is complete and the result is available. Refer to EVCTRL register for details.
- Window Monitor (WINMON): Generated when the window monitor condition match. Refer to CTRLB register for details.

Setting an Event Output bit in the Event Control Register (EVCTRL.xxEO=1) enables the corresponding output event. Clearing this bit disables the corresponding output event. Refer to the Event System chapter for details on configuring the event system.

# SAM D5x/E5x Family Data Sheet

## ADC – Analog-to-Digital Converter

The ADC can take the following actions on an input event:

- Start conversion (START): Start a conversion. Refer to SWTRIG register for details.
- Conversion flush (FLUSH): Flush the conversion. Refer to SWTRIG register for details.

Setting an Event Input bit in the Event Control register (EVCTRL.xxEI=1) enables the corresponding action on input event. Clearing this bit disables the corresponding action on input event.

The ADC uses only asynchronous events, so the asynchronous Event System channel path must be configured. By default, the ADC will detect a rising edge on the incoming event. If the ADC action must be performed on the falling edge of the incoming event, the event line must be inverted first. This is done by setting the corresponding Event Invert Enable bit in Event Control register (EVCTRL.xINV=1).

**Note:** If several events are connected to the ADC, the enabled action will be taken on any of the incoming events. If FLUSH and START events are available at the same time, the FLUSH event has priority.

### Related Links

[45.8.2 EVCTRL](#)

[45.8.5 CTRLB](#)

[45.8.13 SWTRIG](#)

[31. EVSYS – Event System](#)

### 45.6.7 Sleep Mode Operation

The ONDEMAND and RUNSTDBY bits in the Control A register (CTRLA) control the behavior of the ADC during standby sleep mode, in cases where the ADC is enabled (CTRLA.ENABLE = 1). For further details on available options, refer to [Table 45-6](#).

**Note:** When CTRLA.ONDEMAND=1, the analog block is powered-off when the conversion is complete. When a start request is detected, the system returns from sleep and starts a new conversion after the start-up time delay.

**Table 45-6. ADC Sleep Behavior**

CTRLA.RUNSTDBY	CTRLA.ONDEMAND	CTRLA.ENABLE	Description
x	x	0	Disabled
0	0	1	Run in all sleep modes except STANDBY.
0	1	1	Run in all sleep modes on request, except STANDBY.
1	0	1	Run in all sleep modes.
1	1	1	Run in all sleep modes on request.

### 45.6.8 Synchronization

Due to asynchronicity between the main clock domain and the peripheral clock domains, some registers need to be synchronized when written or read.

The following bits are synchronized when written:

- Software Reset bit in Control A register (CTRLA.SWRST)
- Enable bit in Control A register (CTRLA.ENABLE)

# SAM D5x/E5x Family Data Sheet

## ADC – Analog-to-Digital Converter

---

---

The following registers are synchronized when written:

- Input Control register (INPUTCTRL)
- Control B register (CTRLB)
- Reference Control (REFCTRL)
- Average control register (AVGCTRL)
- Sampling time control register (SAMPCTRL)
- Window Monitor Lower Threshold register (WINLT)
- Window Monitor Upper Threshold register (WINUT)
- Gain correction register (GAINCORR)
- Offset Correction register (OFFSETCORR)
- Software Trigger register (SWTRIG)

Required write synchronization is denoted by the "Write-Synchronized" property in the register description.

# SAM D5x/E5x Family Data Sheet

## ADC – Analog-to-Digital Converter

### 45.7 Register Summary

Offset	Name	Bit Pos.									
0x00	CTRLA	7:0	ONDEMAND	RUNSTDBY	SLAVEEN	DUALSEL[1:0]			ENABLE	SWRST	
		15:8	R2R					PRESCALER[2:0]			
0x02	EVCTRL	7:0			WINMONEO	RESRDYEO	STARTINV	FLUSHINV	STARTEI	FLUSHEI	
0x03	DBGCTRL	7:0								DBGRUN	
0x04	INPUTCTRL	7:0	DIFFMODE					MUXPOS[4:0]			
		15:8	DSEQSTOP					MUXNEG[4:0]			
0x06	CTRLB	7:0				RESSEL[1:0]	CORREN	FREERUN	LEFTADJ		
		15:8					WINSS	WINMODE[2:0]			
0x08	REFCTRL	7:0	REFCOMP				REFSEL[3:0]				
0x09	Reserved										
0x0A	AVGCTRL	7:0		ADJRES[2:0]			SAMPLENUM[3:0]				
0x0B	SAMPCTRL	7:0	OFFCOMP			SAMPLEN[5:0]					
0x0C	WINLT	7:0	WINLT[7:0]								
		15:8	WINLT[15:8]								
0x0E	WINUT	7:0	WINUT[7:0]								
		15:8	WINUT[15:8]								
0x10	GAINCORR	7:0	GAINCORR[7:0]								
		15:8						GAINCORR[11:8]			
0x12	OFFSETCORR	7:0	OFFSETCORR[7:0]								
		15:8						OFFSETCORR[11:8]			
0x14	SWTRIG	7:0						START	FLUSH		
0x15 ... 0x2B	Reserved										
0x2C	INTENCLR	7:0						WINMON	OVERRUN	RESRDY	
0x2D	INTENSET	7:0						WINMON	OVERRUN	RESRDY	
0x2E	INTFLAG	7:0						WINMON	OVERRUN	RESRDY	
0x2F	STATUS	7:0	WCC[5:0]								ADCBUSY
0x30	SYNDBUSY	7:0	WINLT	SAMPCTRL	AVGCTRL	REFCTRL	CTRLB	INPUTCTRL	ENABLE	SWRST	
		15:8					SWTRIG	OFFSETCORR	GAINCORR	WINUT	
		23:16									
		31:24	RBSSW								
0x34	DSEQDATA	7:0	DATA[7:0]								
		15:8	DATA[15:8]								
		23:16	DATA[23:16]								
		31:24	DATA[31:24]								
0x38	DSEQCTRL	7:0	GAINCORR	WINUT	WINLT	SAMPCTRL	AVGCTRL	REFCTRL	CTRLB	INPUTCTRL	
		15:8								OFFSETCORR	
		23:16									
		31:24	AUTOSTART								

# SAM D5x/E5x Family Data Sheet

## ADC – Analog-to-Digital Converter

.....continued

Offset	Name	Bit Pos.								
0x3C	DSEQSTAT	7:0	GAINCORR	WINUT	WINLT	SAMPCTRL	AVGCTRL	REFCTRL	CTRLB	INPUTCTRL
		15:8								OFFSETCORR
		23:16								
		31:24	BUSY							
0x40	RESULT	7:0	RESULT[7:0]							
		15:8	RESULT[15:8]							
0x42 ... 0x43	Reserved									
0x44	RESS	7:0	RESS[7:0]							
		15:8	RESS[15:8]							
0x46 ... 0x47	Reserved									
0x48	CALIB	7:0		BIASR2R[2:0]				BIASCOMP[2:0]		
		15:8						BIASREFBUF[2:0]		

### 45.8 Register Description

Registers can be 8, 16, or 32 bits wide. Atomic 8-, 16- and 32-bit accesses are supported. In addition, the 8-bit quarters and 16-bit halves of a 32-bit register, and the 8-bit halves of a 16-bit register can be accessed directly.

Some registers are optionally write-protected by the Peripheral Access Controller (PAC). Optional PAC write protection is denoted by the "PAC Write-Protection" property in each individual register description. For details, refer to the section on Synchronization.

Some registers are synchronized when read and/or written. Synchronization is denoted by the "Write-Synchronized" or the "Read-Synchronized" property in each individual register description. For details, refer to Synchronization section.

Some registers are enable-protected, meaning they can only be written when the peripheral is disabled. Enable-protection is denoted by the "Enable-Protected" property in each individual register description.

#### Related Links

[45.6.8 Synchronization](#)

# SAM D5x/E5x Family Data Sheet

## ADC – Analog-to-Digital Converter

### 45.8.1 Control A

**Name:** CTRLA  
**Offset:** 0x00  
**Reset:** 0x0000  
**Property:** Enable-Protected, PAC Write-Protection, Write-Synchronized

	Bit	15	14	13	12	11	10	9	8	
		R2R					PRESCALER[2:0]			
Access		R/W						R/W	R/W	R/W
Reset		0						0	0	0
	Bit	7	6	5	4	3	2	1	0	
		ONDEMAND	RUNSTDBY	SLAVEEN	DUALSEL[1:0]			ENABLE	SWRST	
Access		R/W	R/W	R/W	R/W	R/W		R/W	R/W	
Reset		0	0	0	0	0		0	0	

#### Bit 15 – R2R Rail to Rail Operation Enable

Value	Description
0	Rail-to-Rail operation disable
1	Rail-to-Rail operation enable. The R2R bit must be set to '1' only in differential mode.

#### Bits 10:8 – PRESCALER[2:0] Prescaler Configuration

This field defines the ADC clock relative to the peripheral clock according Table below. This field is not synchronized. For the slave ADC, these bits have no effect when the SLAVEEN bit is set (CTRLA.SLAVEEN= 1).

Value	Name	Description
0x0	DIV2	Peripheral clock divided by 2
0x1	DIV4	Peripheral clock divided by 4
0x2	DIV8	Peripheral clock divided by 8
0x3	DIV16	Peripheral clock divided by 16
0x4	DIV32	Peripheral clock divided by 32
0x5	DIV64	Peripheral clock divided by 64
0x6	DIV128	Peripheral clock divided by 128
0x7	DIV256	Peripheral clock divided by 256

#### Bit 7 – ONDEMAND On Demand Control

The On Demand operation mode allows the ADC to be enabled or disabled, depending on other peripheral requests.

In On Demand operation mode, i.e., if the ONDEMAND bit has been previously set, the ADC will only be running when requested by a peripheral. If there is no peripheral requesting the ADC will be in a disable state.

If On Demand is disabled the ADC will always be running when enabled.

In standby sleep mode, the On Demand operation is still active if the CTRLA.RUNSTDBY bit is '1'. If CTRLA.RUNSTDBY is '0', the ADC is disabled.

This bit is not synchronized.

**Note:** For the slave ADC, this bit has no effect when the SLAVEEN bit is set (CTRLA.SLAVEEN= 1). ONDEMAND bit from master ADC instance will control the On Demand operation mode.



# SAM D5x/E5x Family Data Sheet

## ADC – Analog-to-Digital Converter

Value	Description
0	The ADC is always on , if enabled.
1	The ADC is enabled, when a peripheral is requesting the ADC conversion. The ADC is disabled if no peripheral is requesting it.

### Bit 6 – RUNSTDBY Run in Standby

This bit controls how the ADC behaves during standby sleep mode.

This bit is not synchronized.

**Note:** For the slave ADC, this bit has no effect when the SLAVEEN bit is set (CTRLA.SLAVEEN= 1). RUNSTDBY bit from master ADC instance will control the slave ADC operation in standby sleep mode.

Value	Description
0	The ADC is halted during standby sleep mode.
1	The ADC is not stopped in standby sleep mode. If CTRLA.ONDEMAND=1, the ADC will be running when a peripheral is requesting it. If CTRLA.ONDEMAND=0, the ADC will always be running in standby sleep mode.

### Bit 5 – SLAVEEN Slave Enable

This bit enables the master/slave operation and it is available only in the slave ADC instance.

This bit is not synchronized and can be set only for the slave ADC. For the master ADC, this bit is always read zero.

Value	Description
0	The master/slave operation is disabled
1	The ADC1 is enabled as a slave of ADC0

### Bits 4:3 – DUALSEL[1:0] Dual Mode Trigger Selection

These bits define the trigger mode, as shown in Table below. These bits are available in the master ADC and have no effect if the master/slave operation is disabled (ADC1.CTRLA.SLAVEEN=0).

Value	Name	Description
0x0	BOTH	Start event or software trigger will start a conversion on both ADCs
0x1	INTERLEAVE	START event or software trigger will alternately start a conversion on ADC0 and ADC1. <b>Note:</b> The interleaved sampling is only usable in single conversion mode (ADC.CTRLB.FREERUN=0).
0x2 – 0x3		Reserved

### Bit 1 – ENABLE Enable

Due to synchronization there is delay from writing CTRLA.ENABLE until the peripheral is enabled/disabled. The value written to CTRLA.ENABLE will read back immediately and the ENABLE bit in the Synchronization Busy register (SYNCBUSY.ENABLE) will be set. SYNCBUSY.ENABLE will be cleared when the operation is complete.

For the slave ADC, this bit has no effect when the SLAVEEN bit is set (CTRLA.SLAVEEN= 1).

Value	Description
0	The ADC is disabled.
1	The ADC is enabled.

### Bit 0 – SWRST Software Reset

Writing a '0' to this bit has no effect.

# SAM D5x/E5x Family Data Sheet

## ADC – Analog-to-Digital Converter

Writing a '1' to this bit resets all registers in the ADC, except DBGCTRL, to their initial state, and the ADC will be disabled.

Writing a '1' to CTRL.SWRST will always take precedence, meaning that all other writes in the same write-operation will be discarded.

Due to synchronization there is a delay from writing CTRLA.SWRST until the reset is complete.

CTRLA.SWRST and SYNCBUSY.SWRST will both be cleared when the reset is complete.

Value	Description
0	There is no reset operation ongoing.
1	The reset operation is ongoing.

# SAM D5x/E5x Family Data Sheet

## ADC – Analog-to-Digital Converter

### 45.8.2 Event Control

**Name:** EVCTRL  
**Offset:** 0x02  
**Reset:** 0x00  
**Property:** PAC Write-Protection

	7	6	5	4	3	2	1	0
			WINMONEO	RESRDYEO	STARTINV	FLUSHINV	STARTEI	FLUSHEI
Access			R/W	R/W	R/W	R/W	R/W	R/W
Reset			0	0	0	0	0	0

#### Bit 5 – WINMONEO Window Monitor Event Out

This bit indicates whether the Window Monitor event output is enabled or not and an output event will be generated when the window monitor detects something.

Value	Description
0	Window Monitor event output is disabled and an event will not be generated.
1	Window Monitor event output is enabled and an event will be generated.

#### Bit 4 – RESRDYEO Result Ready Event Out

This bit indicates whether the Result Ready event output is enabled or not and an output event will be generated when the conversion result is available.

Value	Description
0	Result Ready event output is disabled and an event will not be generated.
1	Result Ready event output is enabled and an event will be generated.

#### Bit 3 – STARTINV Start Conversion Event Invert Enable

For the slave ADC, this bit has no effect when the SLAVEEN bit is set (CTRLA.SLAVEEN= 1).

Value	Description
0	Start event input source is not inverted.
1	Start event input source is inverted.

#### Bit 2 – FLUSHINV Flush Event Invert Enable

For the slave ADC, this bit has no effect when the SLAVEEN bit is set (CTRLA.SLAVEEN= 1).

Value	Description
0	Flush event input source is not inverted.
1	Flush event input source is inverted.

#### Bit 1 – STARTEI Start Conversion Event Input Enable

For the slave ADC, this bit has no effect when the SLAVEEN bit is set (CTRLA.SLAVEEN= 1).

Value	Description
0	A new conversion will not be triggered on any incoming event.
1	A new conversion will be triggered on any incoming event.

#### Bit 0 – FLUSHEI Flush Event Input Enable

For a slave ADC, this bit has no effect when the respective SLAVEEN bit is set (CTRLA.SLAVEEN= 1).

Value	Description
0	A flush and new conversion will not be triggered on any incoming event.

# SAM D5x/E5x Family Data Sheet

## ADC – Analog-to-Digital Converter

---

---

Value	Description
1	A flush and new conversion will be triggered on any incoming event.

# SAM D5x/E5x Family Data Sheet

## ADC – Analog-to-Digital Converter

### 45.8.3 Debug Control

**Name:** DBGCTRL  
**Offset:** 0x03  
**Reset:** 0x00  
**Property:** PAC Write-Protection

Bit	7	6	5	4	3	2	1	0
								DBGRUN
Access								R/W
Reset								0

#### Bit 0 – DBGRUN Debug Run

This bit is not reset by a software reset.

This bit controls the functionality when the CPU is halted by an external debugger.

This bit should be written only while a conversion is not ongoing.

When slave operation is enabled, master and slave ADC instances must have the same DBGRUN bit value to ensure proper operation.

Value	Description
0	The ADC is halted when the CPU is halted by an external debugger.
1	The ADC continues normal operation when the CPU is halted by an external debugger.

# SAM D5x/E5x Family Data Sheet

## ADC – Analog-to-Digital Converter

### 45.8.4 Input Control

**Name:** INPUTCTRL  
**Offset:** 0x04  
**Reset:** 0x0000  
**Property:** PAC Write-Protection, Write-Synchronized

	Bit	15	14	13	12	11	10	9	8
		DSEQSTOP				MUXNEG[4:0]			
Access		R/W			R/W	R/W	R/W	R/W	R/W
Reset		0			0	0	0	0	0
	Bit	7	6	5	4	3	2	1	0
		DIFFMODE				MUXPOS[4:0]			
Access		R/W			R/W	R/W	R/W	R/W	R/W
Reset		0			0	0	0	0	0

#### Bit 15 – DSEQSTOP Stop DMA Sequencing

When the bit is set, the DMA sequencing automatically stops when the last sequence configuration is complete.

**Note:** one more conversion will be done after the last sequence is complete.

#### Bits 12:8 – MUXNEG[4:0] Negative MUX Input Selection

These bits define the MUX selection for the negative ADC input.

Value	Name	Description
0x00	AIN0	ADC AIN0 pin
0x01	AIN1	ADC AIN1 pin
0x02	AIN2	ADC AIN2 pin
0x03	AIN3	ADC AIN3 pin
0x04	AIN4	ADC AIN4 pin
0x05	AIN5	ADC AIN5 pin
0x06	AIN6	ADC AIN6 pin
0x07	AIN7	ADC AIN7 pin
0x08 – 0x17		Reserved
0x18	GND	Internal ground
0x19 – 0x1F		Reserved

#### Bit 7 – DIFFMODE Differential Mode

Value	Description
0x0	The ADC is running in singled-ended mode.
0x1	The ADC is running in differential mode. In this mode, the voltage difference between the MUXPOS and MUXNEG inputs will be converted by the ADC.

#### Bits 4:0 – MUXPOS[4:0] Positive MUX Input Selection

These bits define the MUX selection for the positive ADC input. If the internal bandgap voltage or temperature sensor input channel is selected, then the Sampling Time Length bit group in the Sampling

# SAM D5x/E5x Family Data Sheet

## ADC – Analog-to-Digital Converter

Control register must be written with a corresponding value, as shown in “Table 54-24. Operating Conditions”.

Value	Name	Description
0x00	AIN0	ADC AIN0 pin
0x01	AIN1	ADC AIN1 pin
0x02	AIN2	ADC AIN2 pin
0x03	AIN3	ADC AIN3 pin
0x04	AIN4	ADC AIN4 pin
0x05	AIN5	ADC AIN5 pin
0x06	AIN6	ADC AIN6 pin
0x07	AIN7	ADC AIN7 pin
0x08	AIN8	ADC AIN8 pin
0x09	AIN9	ADC AIN9 pin
0x0A	AIN10	ADC AIN10 pin
0x0B	AIN11	ADC AIN11 pin
0x0C	AIN12	ADC AIN12 pin
0x0D	AIN13	ADC AIN13 pin
0x0E	AIN14	ADC AIN14 pin
0x0F	AIN15	ADC AIN15 pin
0x10	AIN16	ADC AIN16 pin
0x11	AIN17	ADC AIN17 pin
0x12	AIN18	ADC AIN18 pin
0x13	AIN19	ADC AIN19 pin
0x14	AIN20	ADC AIN20 pin
0x15	AIN21	ADC AIN21 pin
0x16	AIN22	ADC AIN22 pin
0x17	AIN23	ADC AIN23 pin
0x18	SCALED COREVCC	1/4 Scaled Core Supply
0x19	SCALED VBAT	1/4 Scaled VBAT Supply
0x1A	SCALED I/OVCC	1/4 Scaled I/O Supply
0x1B	BANDGAP	Bandgap Voltage
0x1C	PTAT	Temperature Sensor
0x1D	CTAT	Temperature Sensor
0x1E	DAC	DAC Output

# SAM D5x/E5x Family Data Sheet

## ADC – Analog-to-Digital Converter

### 45.8.5 Control B

**Name:** CTRLB  
**Offset:** 0x06  
**Reset:** 0x0000  
**Property:** PAC Write-Protection, Write-Synchronized

	Bit	15	14	13	12	11	10	9	8	
						WINSS	WINMODE[2:0]			
Access						R/W	R/W	R/W	R/W	
Reset						0	0	0	0	
	Bit	7	6	5	4	3	2	1	0	
					RESSEL[1:0]		CORREN	FREERUN	LEFTADJ	
Access					R/W	R/W	R/W	R/W	R/W	
Reset					0	0	0	0	0	

#### Bit 11 – WINSS Window Single Sample

When this bit is written the window functionality is working on each conversions and not on the accumulated value. The number of conversions matching with the window comparator is available on STATUS register (STATUS.WCC). The last sample result is available on RESS register.

#### Bits 10:8 – WINMODE[2:0] Window Monitor Mode

These bits enable and define the window monitor mode.

Value	Name	Description
0x0	DISABLE	No window mode (default)
0x1	MODE1	RESULT > WINLT
0x2	MODE2	RESULT < WINUT
0x3	MODE3	WINLT < RESULT < WINUT
0x4	MODE4	!(WINLT < RESULT < WINUT)
0x5 – 0x7		Reserved

#### Bits 4:3 – RESSEL[1:0] Conversion Result Resolution

These bits define whether the ADC completes the conversion 12-, 10- or 8-bit result resolution.

Value	Name	Description
0x0	12BIT	12-bit result
0x1	16BIT	For averaging mode output
0x2	10BIT	10-bit result
0x3	8BIT	8-bit result

#### Bit 2 – CORREN Digital Correction Logic Enable

The ADC conversion result in the RESULT register is then corrected for gain and offset based on the values in the GAINCORR and OFFSETCORR registers. Conversion time will be increased by 13 cycles according to the value in the Offset Correction Value bit group in the Offset Correction register.

Value	Description
0	Disable the digital result correction
1	Enable the digital result correction



# SAM D5x/E5x Family Data Sheet

## ADC – Analog-to-Digital Converter

---

---

### Bit 1 – FREERUN Free Running Mode

Value	Description
0	The ADC run in single conversion mode
1	The ADC is in free running mode and a new conversion will be initiated when a previous conversion completes

### Bit 0 – LEFTADJ Left-Adjusted Result

The high byte of the 12-bit result will be present in the upper part of the result register. Writing this bit to zero (default) will right-adjust the value in the RESULT register.

Value	Description
0	The ADC conversion result is right-adjusted in the RESULT register
1	The ADC conversion result is left-adjusted in the RESULT register

# SAM D5x/E5x Family Data Sheet

## ADC – Analog-to-Digital Converter

### 45.8.6 Reference Control

**Name:** REFCTRL  
**Offset:** 0x08  
**Reset:** 0x00  
**Property:** PAC Write-Protection, Write-Synchronized

Bit	7	6	5	4	3	2	1	0
	REFCOMP				REFSEL[3:0]			
Access	R/W				R/W	R/W	R/W	R/W
Reset	0				0	0	0	0

#### Bit 7 – REFCOMP Reference Buffer Offset Compensation Enable

The gain error can be reduced by enabling the reference buffer offset compensation. This will increase the start-up time of the reference.

Value	Description
0	Reference buffer offset compensation is disabled.
1	Reference buffer offset compensation is enabled.

#### Bits 3:0 – REFSEL[3:0] Reference Selection

These bits select the reference for the ADC.

Value	Name	Description
0x0	INTREF	internal bandgap reference, refer to the SUPC.VREF.SEL register for more details
x01		Reserved
0x2	INTVCC0	1/2 VDDANA (only for VDDANA > 2.0v)
0x3	INTVCC1	VDDANA
0x4	AREFA	External reference
0x5	AREFB	External reference
0x6	AREFC	External reference (ADC1 only)
other	-	Reserved

# SAM D5x/E5x Family Data Sheet

## ADC – Analog-to-Digital Converter

### 45.8.7 Average Control

**Name:** AVGCTRL  
**Offset:** 0x0A  
**Reset:** 0x00  
**Property:** PAC Write-Protection, Write-Synchronized

	Bit	7	6	5	4	3	2	1	0
			ADJRES[2:0]			SAMPLENUM[3:0]			
Access			R/W	R/W	R/W	R/W	R/W	R/W	R/W
Reset			0	0	0	0	0	0	0

**Bits 6:4 – ADJRES[2:0]** Adjusting Result / Division Coefficient  
 These bits define the division coefficient in 2<sup>n</sup> steps.

**Bits 3:0 – SAMPLENUM[3:0]** Number of Samples to be Collected  
 These bits define how many samples are added together. The result will be available in the Result register (RESULT). Note: if the result width increases, CTRLB.RESSEL must be changed.

Value	Description
0x0	1 sample
0x1	2 samples
0x2	4 samples
0x3	8 samples
0x4	16 samples
0x5	32 samples
0x6	64 samples
0x7	128 samples
0x8	256 samples
0x9	512 samples
0xA	1024 samples
0xB –	Reserved
0xF	

# SAM D5x/E5x Family Data Sheet

## ADC – Analog-to-Digital Converter

### 45.8.8 Sampling Time Control

**Name:** SAMPCTRL  
**Offset:** 0x0B  
**Reset:** 0x00  
**Property:** PAC Write-Protection, Write-Synchronized

	7	6	5	4	3	2	1	0
	OFFCOMP		SAMPLEN[5:0]					
Access	R/W		R/W	R/W	R/W	R/W	R/W	R/W
Reset	0		0	0	0	0	0	0

**Bit 7 – OFFCOMP** Comparator Offset Compensation Enable

Setting this bit enables the offset compensation for each sampling period to ensure low offset and immunity to temperature or voltage drift. This compensation increases the sampling time by three clock cycles that results in a fixed sampling duration of 4 CLK\_ADC cycles.

This bit must be set to zero to validate the SAMPLEN value. It's not possible to use OFFCOMP=1 and SAMPLEN>0.

**Bits 5:0 – SAMPLEN[5:0]** Sampling Time Length

These bits control the ADC sampling time in number of CLK\_ADC cycles, depending of the prescaler value, thus controlling the ADC input impedance. Sampling time is set according to the equation:

$$\text{Sampling time} = (\text{SAMPLEN} + 1) \cdot (\text{CLK}_{\text{ADC}})$$

# SAM D5x/E5x Family Data Sheet

## ADC – Analog-to-Digital Converter

### 45.8.9 Window Monitor Lower Threshold

**Name:** WINLT  
**Offset:** 0x0C  
**Reset:** 0x0000  
**Property:** PAC Write-Protection, Write-Synchronized

Bit	15	14	13	12	11	10	9	8
WINLT[15:8]								
Access	R/W	R/W	R/W	R/W	R/W	R/W	R/W	R/W
Reset	0	0	0	0	0	0	0	0
Bit	7	6	5	4	3	2	1	0
WINLT[7:0]								
Access	R/W	R/W	R/W	R/W	R/W	R/W	R/W	R/W
Reset	0	0	0	0	0	0	0	0

**Bits 15:0 – WINLT[15:0]** Window Lower Threshold  
 If the window monitor is enabled, these bits define the lower threshold value.

# SAM D5x/E5x Family Data Sheet

## ADC – Analog-to-Digital Converter

### 45.8.10 Window Monitor Upper Threshold

**Name:** WINUT  
**Offset:** 0x0E  
**Reset:** 0x0000  
**Property:** PAC Write-Protection, Write-Synchronized

	Bit	15	14	13	12	11	10	9	8
		WINUT[15:8]							
Access		R/W	R/W	R/W	R/W	R/W	R/W	R/W	R/W
Reset		0	0	0	0	0	0	0	0
	Bit	7	6	5	4	3	2	1	0
		WINUT[7:0]							
Access		R/W	R/W	R/W	R/W	R/W	R/W	R/W	R/W
Reset		0	0	0	0	0	0	0	0

**Bits 15:0 – WINUT[15:0]** Window Upper Threshold  
 If the window monitor is enabled, these bits define the upper threshold value.

# SAM D5x/E5x Family Data Sheet

## ADC – Analog-to-Digital Converter

### 45.8.11 Gain Correction

**Name:** GAINCORR  
**Offset:** 0x10  
**Reset:** 0x0000  
**Property:** PAC Write-Protection, Write-Synchronized

	15	14	13	12	11	10	9	8
	GAINCORR[11:8]							
Access					R/W	R/W	R/W	R/W
Reset					0	0	0	0
	7	6	5	4	3	2	1	0
	GAINCORR[7:0]							
Access	R/W	R/W	R/W	R/W	R/W	R/W	R/W	R/W
Reset	0	0	0	0	0	0	0	0

**Bits 11:0 – GAINCORR[11:0]** Gain Correction Value

If CTRLB.CORREN=1, these bits define how the ADC conversion result is compensated for gain error before being written to the result register. The gain correction is a fractional value, a 1-bit integer plus an 11-bit fraction, and therefore  $\frac{1}{2} \leq \text{GAINCORR} < 2$ . GAINCORR values range from 0.1000000000 to 1.1111111111.

# SAM D5x/E5x Family Data Sheet

## ADC – Analog-to-Digital Converter

### 45.8.12 Offset Correction

**Name:** OFFSETCORR  
**Offset:** 0x12  
**Reset:** 0x0000  
**Property:** PAC Write-Protection, Write-Synchronized

Bit	15	14	13	12	11	10	9	8
					OFFSETCORR[11:8]			
Access					R/W	R/W	R/W	R/W
Reset					0	0	0	0
Bit	7	6	5	4	3	2	1	0
	OFFSETCORR[7:0]							
Access	R/W	R/W	R/W	R/W	R/W	R/W	R/W	R/W
Reset	0	0	0	0	0	0	0	0

**Bits 11:0 – OFFSETCORR[11:0]** Offset Correction Value

If CTRLB.CORREN=1, these bits define how the ADC conversion result is compensated for offset error before being written to the Result register. This OFFSETCORR value is in two's complement format.



# SAM D5x/E5x Family Data Sheet

## ADC – Analog-to-Digital Converter

### 45.8.13 Software Trigger

**Name:** SWTRIG  
**Offset:** 0x14  
**Reset:** 0x00  
**Property:** PAC Write-Protection, Write-Synchronized

Bit	7	6	5	4	3	2	1	0
							START	FLUSH
Access							W	RW
Reset							0	0

#### Bit 1 – START Start ADC Conversion

Writing a '1' to this bit will start a conversion or sequence. The bit is cleared by hardware when the conversion has started. Writing a '1' to this bit when it is already set has no effect.

Writing a '0' to this bit has no effect.

#### Bit 0 – FLUSH ADC Conversion Flush

Writing a '1' to this bit will flush the ADC pipeline. A flush will restart the ADC clock on the next peripheral clock edge, and all conversions in progress will be aborted and lost. This bit will be cleared after the ADC has been flushed.

After the flush, the ADC will resume where it left off; i.e., if a conversion was pending, the ADC will start a new conversion.

Writing a '0' to this bit has no effect.

# SAM D5x/E5x Family Data Sheet

## ADC – Analog-to-Digital Converter

### 45.8.14 Interrupt Enable Clear

**Name:** INTENCLR  
**Offset:** 0x2C  
**Reset:** 0x00  
**Property:** PAC Write-Protection

This register allows the user to disable an interrupt without doing a read-modify-write operation. Changes in this register will also be reflected in the Interrupt Enable Set (INTENSET) register.

	7	6	5	4	3	2	1	0
						WINMON	OVERRUN	RESRDY
Access						R/W	R/W	R/W
Reset						0	0	0

#### Bit 2 – WINMON Window Monitor Interrupt Disable

Writing a '0' to this bit has no effect.

Writing a '1' to this bit will clear the Window Monitor Interrupt Enable bit, which disables the corresponding interrupt request.

Value	Description
0	The window monitor interrupt is disabled.
1	The window monitor interrupt is enabled, and an interrupt request will be generated when the Window Monitor interrupt flag is set.

#### Bit 1 – OVERRUN Overrun Interrupt Disable

Writing a '0' to this bit has no effect.

Writing a '1' to this bit will clear the Overrun Interrupt Enable bit, which disables the corresponding interrupt request.

Value	Description
0	The Overrun interrupt is disabled.
1	The Overrun interrupt is enabled, and an interrupt request will be generated when the Overrun interrupt flag is set.

#### Bit 0 – RESRDY Result Ready Interrupt Disable

Writing a '0' to this bit has no effect.

Writing a '1' to this bit will clear the Result Ready Interrupt Enable bit, which disables the corresponding interrupt request.

Value	Description
0	The Result Ready interrupt is disabled.
1	The Result Ready interrupt is enabled, and an interrupt request will be generated when the Result Ready interrupt flag is set.

### 45.8.15 Interrupt Enable Set

**Name:** INTENSET  
**Offset:** 0x2D  
**Reset:** 0x00  
**Property:** PAC Write-Protection

This register allows the user to enable an interrupt without doing a read-modify-write operation. Changes in this register will also be reflected in the Interrupt Enable Clear (INTENCLR) register.

	7	6	5	4	3	2	1	0
						WINMON	OVERRUN	RESRDY
Access						R/W	R/W	R/W
Reset						0	0	0

#### Bit 2 – WINMON Window Monitor Interrupt Enable

Writing a '0' to this bit has no effect.

Writing a '1' to this bit will set the Window Monitor Interrupt bit, which enables the Window Monitor interrupt.

Value	Description
0	The Window Monitor interrupt is disabled.
1	The Window Monitor interrupt is enabled.

#### Bit 1 – OVERRUN Overrun Interrupt Enable

Writing a '0' to this bit has no effect.

Writing a '1' to this bit will set the Overrun Interrupt bit, which enables the Overrun interrupt.

Value	Description
0	The Overrun interrupt is disabled.
1	The Overrun interrupt is enabled.

#### Bit 0 – RESRDY Result Ready Interrupt Enable

Writing a '0' to this bit has no effect.

Writing a '1' to this bit will set the Result Ready Interrupt bit, which enables the Result Ready interrupt.

Value	Description
0	The Result Ready interrupt is disabled.
1	The Result Ready interrupt is enabled.

# SAM D5x/E5x Family Data Sheet

## ADC – Analog-to-Digital Converter

### 45.8.16 Interrupt Flag Status and Clear

**Name:** INTFLAG  
**Offset:** 0x2E  
**Reset:** 0x00  
**Property:** –

	7	6	5	4	3	2	1	0
Bit						WINMON	OVERRUN	RESRDY
Access						R/W	R/W	R/W
Reset						0	0	0

**Bit 2 – WINMON** Window Monitor Interrupt Flag

This flag is cleared by writing a '1' to the flag or by reading the RESULT register.

This flag is set on the next GCLK\_ADC cycle after a match with the window monitor condition, and an interrupt request will be generated if INTENCLR/SET.WINMON is '1'.

Writing a '0' to this bit has no effect.

Writing a '1' to this bit clears the Window Monitor interrupt flag.

**Bit 1 – OVERRUN** Overrun Interrupt Flag

This flag is cleared by writing a '1' to the flag.

This flag is set if RESULT is written before the previous value has been read by CPU, and an interrupt request will be generated if INTENCLR/SET.OVERRUN=1.

Writing a '0' to this bit has no effect.

Writing a '1' to this bit clears the Overrun interrupt flag.

**Bit 0 – RESRDY** Result Ready Interrupt Flag

This flag is cleared by writing a '1' to the flag or by reading the RESULT register.

This flag is set when the conversion result is available, and an interrupt will be generated if INTENCLR/SET.RESRDY=1.

Writing a '0' to this bit has no effect.

Writing a '1' to this bit clears the Result Ready interrupt flag.

# SAM D5x/E5x Family Data Sheet

## ADC – Analog-to-Digital Converter

### 45.8.17 STATUS

**Name:** STATUS  
**Offset:** 0x2F  
**Reset:** 0x00  
**Property:** -

Bit	7	6	5	4	3	2	1	0
	WCC[5:0]							ADCBUSY
Access	R	R	R	R	R	R		R
Reset	0	0	0	0	0	0		0

**Bits 7:2 – WCC[5:0]** Window Comparator Counter

These bits indicates the number of sample matching with the window comparator.

Writing a zero to this bit will have no effect.

Writing a one to this bit will have no effect.

**Bit 0 – ADCBUSY** ADC Busy Status

This bit is read one when the data acquisition in on going.

Writing a zero to this bit will have no effect.

Writing a one to this bit will have no effect.

# SAM D5x/E5x Family Data Sheet

## ADC – Analog-to-Digital Converter

### 45.8.18 Synchronization Busy

**Name:** SYNCBUSY  
**Offset:** 0x30  
**Reset:** 0x00000000  
**Property:** -

	31	30	29	28	27	26	25	24	
	RBSSW								
Access	R								
Reset	0								
	23	22	21	20	19	18	17	16	
Access									
Reset									
	15	14	13	12	11	10	9	8	
					SWTRIG	OFFSETCORR	GAINCORR	WINUT	
Access					R	R	R	R	
Reset					0	0	0	0	
	7	6	5	4	3	2	1	0	
	WINLT	SAMPCTRL	AVGCTRL	REFCTRL	CTRLB	INPUTCTRL	ENABLE	SWRST	
Access	R	R	R	R	R	R	R	R	
Reset	0	0	0	0	0	0	0	0	

**Bit 31 – RBSSW** Reset BootStrap Switch Synchronization Busy

**Bit 11 – SWTRIG** Software Trigger Synchronization Busy

This bit is cleared when the synchronization of SWTRIG register between the clock domains is complete. This bit is set when the synchronization of SWTRIG register between clock domains is started.

**Note:** For the slave ADC, this bit is always read zero when the SLAVEEN bit is set (CTRLA.SLAVEEN=1).

**Bit 10 – OFFSETCORR** Offset Correction Synchronization Busy

This bit is cleared when the synchronization of OFFSETCORR register between the clock domains is complete.

This bit is set when the synchronization of OFFSETCORR register between clock domains is started.

**Bit 9 – GAINCORR** Gain Correction Synchronization Busy

This bit is cleared when the synchronization of GAINCORR register between the clock domains is complete.

This bit is set when the synchronization of GAINCORR register between clock domains is started.

**Bit 8 – WINUT** Window Monitor Upper Threshold Synchronization Busy

This bit is cleared when the synchronization of WINUT register between the clock domains is complete.

This bit is set when the synchronization of WINUT register between clock domains is started.

# SAM D5x/E5x Family Data Sheet

## ADC – Analog-to-Digital Converter

---

### **Bit 7 – WINLT** Window Monitor Lower Threshold Synchronization Busy

This bit is cleared when the synchronization of WINLT register between the clock domains is complete.  
This bit is set when the synchronization of WINLT register between clock domains is started.

### **Bit 6 – SAMPCTRL** Sampling Time Control Synchronization Busy

This bit is cleared when the synchronization of SAMPCTRL register between the clock domains is complete.

This bit is set when the synchronization of SAMPCTRL register between clock domains is started.

### **Bit 5 – AVGCTRL** Average Control Synchronization Busy

This bit is cleared when the synchronization of AVGCTRL register between the clock domains is complete.

This bit is set when the synchronization of AVGCTRL register between clock domains is started.

### **Bit 4 – REFCTRL** Reference Control Synchronization Busy

This bit is cleared when the synchronization of REFCTRL register between the clock domains is complete.

This bit is set when the synchronization of REFCTRL register between clock domains is started.

### **Bit 3 – CTRLB** Control B Synchronization Busy

This bit is cleared when the synchronization of CTRLB register between the clock domains is complete.

This bit is set when the synchronization of CTRLB register between clock domains is started.

### **Bit 2 – INPUTCTRL** Input Control Synchronization Busy

This bit is cleared when the synchronization of INPUTCTRL register between the clock domains is complete.

This bit is set when the synchronization of INPUTCTRL register between clock domains is started.

### **Bit 1 – ENABLE** ENABLE Synchronization Busy

This bit is cleared when the synchronization of ENABLE register between the clock domains is complete.

This bit is set when the synchronization of ENABLE register between clock domains is started.

**Note:** For the slave ADC, this bit is always read zero when the SLAVEEN bit is set (CTRLA.SLAVEEN=1).

### **Bit 0 – SWRST** SWRST Synchronization Busy

This bit is cleared when the synchronization of SWRST register between the clock domains is complete.

This bit is set when the synchronization of SWRST register between clock domains is started

# SAM D5x/E5x Family Data Sheet

## ADC – Analog-to-Digital Converter

### 45.8.19 DSEQDATA

**Name:** DSEQDATA  
**Offset:** 0x34  
**Reset:** 0x00000000  
**Property:** PAC Write-Protection

	Bit	31	30	29	28	27	26	25	24
		DATA[31:24]							
Access		W	W	W	W	W	W	W	W
Reset		0	0	0	0	0	0	0	0
	Bit	23	22	21	20	19	18	17	16
		DATA[23:16]							
Access		W	W	W	W	W	W	W	W
Reset		0	0	0	0	0	0	0	0
	Bit	15	14	13	12	11	10	9	8
		DATA[15:8]							
Access		W	W	W	W	W	W	W	W
Reset		0	0	0	0	0	0	0	0
	Bit	7	6	5	4	3	2	1	0
		DATA[7:0]							
Access		W	W	W	W	W	W	W	W
Reset		0	0	0	0	0	0	0	0

**Bits 31:0 – DATA[31:0] DMA Sequential Data**

This register stores data written by the DMA and re-directed to the first enabled ADC registers in the DSEQSTAT register.



# SAM D5x/E5x Family Data Sheet

## ADC – Analog-to-Digital Converter

### 45.8.20 DSEQCTRL

**Name:** DSEQCTRL  
**Offset:** 0x38  
**Reset:** 0x00000000  
**Property:** PAC Write-Protection

	Bit	31	30	29	28	27	26	25	24
		AUTOSTART							
Access		R/W							
Reset		0							
	Bit	23	22	21	20	19	18	17	16
Access									
Reset									
	Bit	15	14	13	12	11	10	9	8
									OFFSETCORR
Access									R/W
Reset									0
	Bit	7	6	5	4	3	2	1	0
		GAINCORR	WINUT	WINLT	SAMPCTRL	AVGCTRL	REFCTRL	CTRLB	INPUTCTRL
Access		R/W	R/W	R/W	R/W	R/W	R/W	R/W	R/W
Reset		0	0	0	0	0	0	0	0

#### Bit 31 – AUTOSTART ADC Auto-Start Conversion

Value	Description
0	ADC conversion starts when a DMA sequence is complete and a start software or event trigger is received.
1	ADC conversion automatically starts when a DMA sequence is complete. This setting is ignored if the conversion start by event is enabled (EVCTRL.STARTEI=1).

#### Bit 8 – OFFSETCORR Offset Correction

Value	Description
0	DMA update of the Offset Correction register is disabled.
1	DMA update of the Offset Correction register is enabled.

#### Bit 7 – GAINCORR Gain Correction

Value	Description
0	DMA update of the Gain Correction register is disabled.
1	DMA update of the Gain Correction register is enabled.

#### Bit 6 – WINUT Window Monitor Upper Threshold

Value	Description
0	DMA update of the Window Monitor Upper Threshold register is disabled.
1	DMA update of the Window Monitor Upper Threshold register is enabled.

# SAM D5x/E5x Family Data Sheet

## ADC – Analog-to-Digital Converter

### Bit 5 – WINLT Window Monitor Lower Threshold

Value	Description
0	DMA update of the Window Monitor Lower Threshold register is disabled.
1	DMA update of the Window Monitor Lower Threshold register is enabled.

### Bit 4 – SAMPCTRL Sampling Time Control

Value	Description
0	DMA update of the Sampling Time Control register is disabled.
1	DMA update of the Sampling Time Control register is enabled.

### Bit 3 – AVGCTRL Average Control

Value	Description
0	DMA update of the Average Control register is disabled.
1	DMA update of the Average Control register is enabled.

### Bit 2 – REFCTRL Reference Control

Value	Description
0	DMA update of the Reference Control register is disabled.
1	DMA update of the Reference Control register is enabled.

### Bit 1 – CTRLB Control B

Value	Description
0	DMA update of the Control B register is disabled.
1	DMA update of the Control B register is enabled.

### Bit 0 – INPUTCTRL Input Control

Value	Description
0	DMA update of the Input Control register is disabled.
1	DMA update of the Input Control register is enabled.

# SAM D5x/E5x Family Data Sheet

## ADC – Analog-to-Digital Converter

### 45.8.21 DSEQSTAT

**Name:** DSEQSTAT  
**Offset:** 0x3C  
**Reset:** 0x00000000  
**Property:** -

	31	30	29	28	27	26	25	24
	BUSY							
Access	R							
Reset	0							
	23	22	21	20	19	18	17	16
Access	R							
Reset	0							
	15	14	13	12	11	10	9	8
								OFFSETCORR
Access								R
Reset								0
	7	6	5	4	3	2	1	0
	GAINCORR	WINUT	WINLT	SAMPCTRL	AVGCTRL	REFCTRL	CTRLB	INPUTCTRL
Access	R	R	R	R	R	R	R	R
Reset	0	0	0	0	0	0	0	0

**Bit 31 – BUSY** DMA Sequencing Busy  
 The bit is set when the DMA sequencing is enabled or restarted.  
 The bit is cleared when the DMA sequencing is disabled.

**Bit 8 – OFFSETCORR** Offset Correction

Value	Description
0	DMA update of the Offset Correction register is complete or disabled.
1	DMA update of the Offset Correction register is enabled.

**Bit 7 – GAINCORR** Gain Correction

Value	Description
0	DMA update of the Gain Correction register is complete or disabled.
1	DMA update of the Gain Correction register is enabled.

**Bit 6 – WINUT** Window Monitor Upper Threshold

Value	Description
0	DMA update of the Window Monitor Upper Threshold register is complete or disabled.
1	DMA update of the Window Monitor Upper Threshold register is enabled.

**Bit 5 – WINLT** Window Monitor Lower Threshold

Value	Description
0	DMA update of the Window Monitor Lower Threshold register is complete or disabled.

# SAM D5x/E5x Family Data Sheet

## ADC – Analog-to-Digital Converter

---

---

Value	Description
1	DMA update of the Window Monitor Lower Threshold register is enabled.

### Bit 4 – SAMPCTRL Sampling Time Control

Value	Description
0	DMA update of the Sampling Time Control register is complete or disabled.
1	DMA update of the Sampling Time Control register is enabled.

### Bit 3 – AVGCTRL Average Control

Value	Description
0	DMA update of the Average Control register is complete or disabled.
1	DMA update of the Average Control register is enabled.

### Bit 2 – REFCTRL Reference Control

Value	Description
0	DMA update of the Reference Control register is complete or disabled.
1	DMA update of the Reference Control register is enabled.

### Bit 1 – CTRLB Control B

Value	Description
0	DMA update of the Control B register is complete or disabled.
1	DMA update of the Control B register is enabled.

### Bit 0 – INPUTCTRL Input Control

Value	Description
0	DMA update of the Input Control register is complete or disabled.
1	DMA update of the Input Control register is enabled.

# SAM D5x/E5x Family Data Sheet

## ADC – Analog-to-Digital Converter

### 45.8.22 Result

**Name:** RESULT  
**Offset:** 0x40  
**Reset:** 0x0000  
**Property:** -

	15	14	13	12	11	10	9	8
	RESULT[15:8]							
Access	R	R	R	R	R	R	R	R
Reset	0	0	0	0	0	0	0	0
	7	6	5	4	3	2	1	0
	RESULT[7:0]							
Access	R	R	R	R	R	R	R	R
Reset	0	0	0	0	0	0	0	0

#### Bits 15:0 – RESULT[15:0] Result Conversion Value

These bits will hold up to a 16-bit ADC conversion result, depending on the configuration.

In single conversion mode without averaging, the ADC conversion will produce a 12-bit result, which can be left- or right-shifted, depending on the setting of CTRLB.LEFTADJ.

If the result is left-adjusted (CTRLB.LEFTADJ), the high byte of the result will be in bit position [15:8], while the remaining 4 bits of the result will be placed in bit locations [7:4]. This can be used only if an 8-bit result is needed; i.e., one can read only the high byte of the entire 16-bit register.

If the result is not left-adjusted (CTRLB.LEFTADJ) and no oversampling is used, the result will be available in bit locations [11:0], and the result is then 12 bits long. If oversampling is used, the result will be located in bit locations [15:0], depending on the settings of the Average Control register.

# SAM D5x/E5x Family Data Sheet

## ADC – Analog-to-Digital Converter

### 45.8.23 RESS

**Name:** RESS  
**Offset:** 0x44  
**Reset:** 0x0000  
**Property:** -

Bit	15	14	13	12	11	10	9	8
RESS[15:8]								
Access	R	R	R	R	R	R	R	R
Reset	0	0	0	0	0	0	0	0
Bit	7	6	5	4	3	2	1	0
RESS[7:0]								
Access	R	R	R	R	R	R	R	R
Reset	0	0	0	0	0	0	0	0

**Bits 15:0 – RESS[15:0]** Last ADC Conversion Result  
 These bits will hold up the last ADC conversion result.

# SAM D5x/E5x Family Data Sheet

## ADC – Analog-to-Digital Converter

### 45.8.24 Calibration

**Name:** CALIB  
**Offset:** 0x48  
**Reset:** 0x0000  
**Property:** PAC Write-Protection, Enable-Protected

	Bit	15	14	13	12	11	10	9	8	
								BIASREFBUF[2:0]		
Access							R/W	R/W	R/W	
Reset							0	0	0	
	Bit	7	6	5	4	3	2	1	0	
					BIASR2R[2:0]					
Access			R/W	R/W	R/W		R/W	R/W	R/W	
Reset			0	0	0		0	0	0	

**Bits 10:8 – BIASREFBUF[2:0]** Bias Reference Buffer Scaling

This value from production test must be loaded from the NVM software calibration row into the CALIB register by software to achieve the specified accuracy. Refer to *NVM Software Calibration Area Mapping* for further details.

The value must be copied only, and must not be changed.

**Bits 6:4 – BIASR2R[2:0]** Bias R2R ampli Scaling

This value from production test must be loaded from the NVM software calibration row into the CALIB register by software to achieve the specified accuracy. Refer to *NVM Software Calibration Area Mapping* for further details.

The value must be copied only, and must not be changed

**Bits 2:0 – BIASCOMP[2:0]** Bias Comparator Scaling

This value from production test must be loaded from the NVM software calibration row into the CALIB register by software to achieve the specified accuracy. Refer to *NVM Software Calibration Area Mapping* for further details.

The value must be copied only, and must not be changed

## 46. AC – Analog Comparators

### 46.1 Overview

The Analog Comparator (AC) supports two individual comparators. Each comparator (COMP) compares the voltage levels on two inputs, and provides a digital output based on this comparison. Each comparator may be configured to generate interrupt requests and/or peripheral events upon several different combinations of input change.

Hysteresis can be adjusted to achieve the optimal operation for each application.

The input selection includes four shared analog port pins and several internal signals. Each Comparator Output state can also be output on a pin for use by external devices.

The comparators are grouped in pairs on each port. The AC peripheral implements one pair of comparators. These are called Comparator 0 (COMP0) and Comparator 1 (COMP1). They have identical behaviors, but separate Control registers. The pair can be set in Window mode to compare a signal to a voltage range instead of a single voltage level.

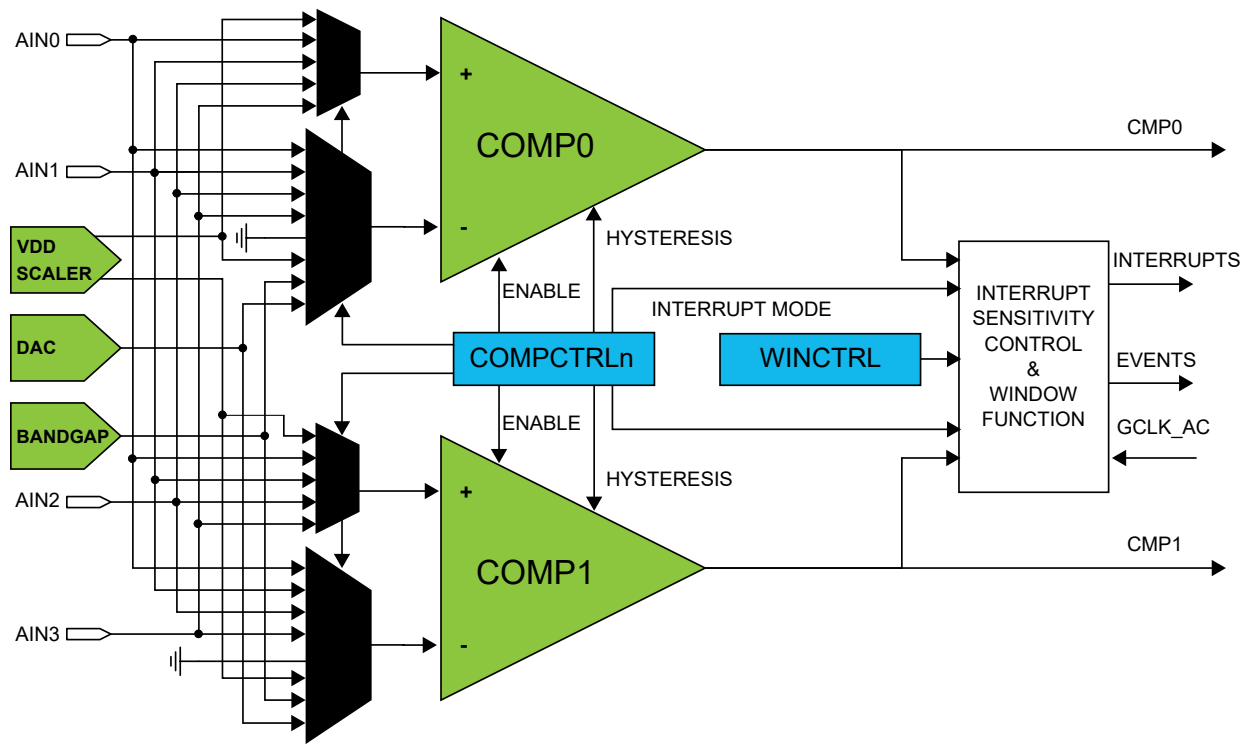
### 46.2 Features

- Up to Two individual comparators
- Selectable hysteresis: 3-level On, or Off
- Hysteresis: On or Off
- Analog comparator outputs available on pins
  - Asynchronous or synchronous
- Flexible input selection:
  - Four pins selectable for positive or negative inputs
  - Ground (for zero crossing)
  - Bandgap reference voltage
  - 64-level programmable VDD scaler per comparator
  - DAC
- Interrupt generation on:
  - Rising or falling edge
  - Toggle
  - End of comparison
- Window function interrupt generation on:
  - Signal above window
  - Signal inside window
  - Signal below window
  - Signal outside window
- Event generation on:
  - Comparator output
  - Window function inside/outside window
- Optional digital filter on comparator output



### 46.3 Block Diagram

Figure 46-1. Analog Comparator Block Diagram



### 46.4 Signal Description

Signal	Description	Type
AIN[3..0]	Analog input	Comparator inputs
CMP[1..0]	Digital output	Comparator outputs

Refer to *I/O Multiplexing and Considerations* for details on the pin mapping for this peripheral. One signal can be mapped on several pins.

#### Related Links

[6. I/O Multiplexing and Considerations](#)

### 46.5 Product Dependencies

In order to use this peripheral, other parts of the system must be configured correctly, as described below.

#### 46.5.1 I/O Lines

Using the AC's I/O lines requires the I/O pins to be configured. Refer to *PORT - I/O Pin Controller* for details.

**Table 46-1. I/O Lines**

Instance	Signal	I/O Line	Peripheral Function
AC0	AIN0	PAxx	A
AC0	AIN1	PAxx	A
AC0	AIN2	PAxx	A
AC0	AIN3	PAxx	A
AC0	CMP0	PAxx	A
AC0	CMP1	PAxx	A

**Related Links**

[32. PORT - I/O Pin Controller](#)

**46.5.2 Power Management**

The AC will continue to operate in any Sleep mode where the selected source clock is running. The AC's interrupts can be used to wake up the device from Sleep modes. Events connected to the Event System can trigger other operations in the system without exiting Sleep modes.

**46.5.3 Clocks**

The AC bus clock (CLK\_AC\_APB) can be enabled and disabled in the Main Clock module, MCLK (see *MCLK - Main Clock*, and the default state of CLK\_AC\_APB can be found in *Peripheral Clock Masking*.

A generic clock (GCLK\_AC) is required to clock the AC. This clock must be configured and enabled in the generic clock controller before using the AC. Refer to the Generic Clock Controller chapter for details.

This generic clock is asynchronous to the bus clock (CLK\_AC\_APB). Due to this asynchronicity, writes to certain registers will require synchronization between the clock domains. Refer to [Synchronization](#) for further details.

**Related Links**

[15.6.2.6 Peripheral Clock Masking](#)

[15. MCLK – Main Clock](#)

**46.5.4 DMA**

Not applicable.

**46.5.5 Interrupts**

The interrupt request lines are connected to the interrupt controller. Using the AC interrupts requires the interrupt controller to be configured first. Refer to *Nested Vector Interrupt Controller* for details.

**Related Links**

[10.2 Nested Vector Interrupt Controller](#)

**46.5.6 Events**

The events are connected to the Event System. Refer to *EVSYS – Event System* for details on how to configure the Event System.

**Related Links**

[31. EVSYS – Event System](#)

### 46.5.7 Debug Operation

When the CPU is halted in debug mode, the AC will halt normal operation after any on-going comparison is completed. The AC can be forced to continue normal operation during debugging. Refer to [DBGCTRL](#) for details. If the AC is configured in a way that requires it to be periodically serviced by the CPU through interrupts or similar, improper operation or data loss may result during debugging.

### 46.5.8 Register Access Protection

All registers with write access can be write-protected optionally by the Peripheral Access Controller (PAC), except for the following registers:

- Control B register (CTRLB)
- Interrupt Flag register (INTFLAG)

Optional write protection by the Peripheral Access Controller (PAC) is denoted by the "PAC Write Protection" property in each individual register description.

PAC write protection does not apply to accesses through an external debugger.

#### Related Links

[27. PAC - Peripheral Access Controller](#)

### 46.5.9 Analog Connections

Each comparator has up to four I/O pins that can be used as analog inputs. Each pair of comparators shares the same four pins. These pins must be configured for analog operation before using them as comparator inputs.

Any internal reference source, such as a bandgap voltage reference, or DAC must be configured and enabled prior to its use as a comparator input.

### 46.5.10 Calibration

The BIAS calibration value from the production test must be loaded from the NVM Software Calibration Area into the AC Calibration register (CALIB) by software to achieve specified accuracy.

## 46.6 Functional Description

### 46.6.1 Principle of Operation

Each comparator has one positive input and one negative input. Each positive input may be chosen from a selection of analog input pins. Each negative input may be chosen from a selection of both analog input pins and internal inputs, such as a bandgap voltage reference.

The digital output from the comparator is '1' when the difference between the positive and the negative input voltage is positive, and '0' otherwise.

The individual comparators can be used independently (Normal mode) or paired to form a window comparison (Window mode).

### 46.6.2 Basic Operation

#### 46.6.2.1 Initialization

Some registers are enable-protected, meaning they can only be written when the module is disabled.

The following register is enable-protected:

- Event Control register (EVCTRL)

Enable-protection is denoted by the "Enable-Protected" property in each individual register description.

### 46.6.2.2 Enabling, Disabling and Resetting

The AC is enabled by writing a '1' to the Enable bit in the Control A register (CTRLA.ENABLE). The AC is disabled writing a '0' to CTRLA.ENABLE.

The AC is reset by writing a '1' to the Software Reset bit in the Control A register (CTRLA.SWRST). All registers in the AC will be reset to their initial state, and the AC will be disabled. Refer to CTRLA for details.

### 46.6.2.3 Comparator Configuration

Each individual comparator must be configured by its respective Comparator Control register (COMPCTRLx) before that comparator is enabled. These settings cannot be changed while the comparator is enabled.

- Select the desired measurement mode with COMPCTRLx.SINGLE. See [Starting a Comparison](#) for more details.
- Select the desired hysteresis with COMPCTRLx.HYSTEN and COMPCTRLx.HYST. See [Input Hysteresis](#) for more details.
- Write COMPCTRLx.SPEED to 0x3.
- Select the interrupt source with COMPCTRLx.INTSEL.
- Select the positive and negative input sources with the COMPCTRLx.MUXPOS and COMPCTRLx.MUXNEG bits. See [Selecting Comparator Inputs](#) for more details.
- Select the filtering option with COMPCTRLx.FLEN.
- Select standby operation with Run in Standby bit (COMPCTRLx.RUNSTDBY).

The individual comparators are enabled by writing a '1' to the Enable bit in the Comparator x Control registers (COMPCTRLx.ENABLE). The individual comparators are disabled by writing a '0' to COMPCTRLx.ENABLE. Writing a '0' to CTRLA.ENABLE will also disable all the comparators, but will not clear their COMPCTRLx.ENABLE bits.

### 46.6.2.4 Starting a Comparison

Each comparator channel can be in one of two different measurement modes, determined by the Single bit in the Comparator x Control register (COMPCTRLx.SINGLE):

- Continuous measurement
- Single-shot

After being enabled, a start-up delay is required before the result of the comparison is ready. This start-up time is measured automatically to account for environmental changes, such as temperature or voltage supply level, and is specified in the *Electrical Characteristics* chapters. During the start-up time, the COMP output is not available.

The comparator can be configured to generate interrupts when the output toggles, when the output changes from '0' to '1' (rising edge), when the output changes from '1' to '0' (falling edge) or at the end of the comparison. An end-of-comparison interrupt can be used with the Single-Shot mode to chain further events in the system, regardless of the state of the comparator outputs. The Interrupt mode is set by the Interrupt Selection bit group in the Comparator Control register (COMPCTRLx.INTSEL). Events are generated using the comparator output state, regardless of whether the interrupt is enabled or not.

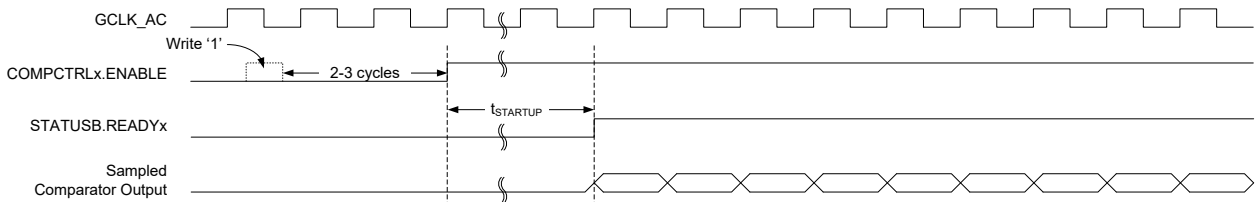
### 46.6.2.4.1 Continuous Measurement

Continuous measurement is selected by writing COMPCTRLx.SINGLE to zero. In continuous mode, the comparator is continuously enabled and performing comparisons. This ensures that the result of the latest comparison is always available in the Current State bit in the Status A register (STATUSA.STATEx).

After the start-up time has passed, a comparison is done and STATUSA is updated. The Comparator x Ready bit in the Status B register (STATUSB.READYx) is set, and the appropriate peripheral events and interrupts are also generated. New comparisons are performed continuously until the COMPCTRLx.ENABLE bit is written to zero. The start-up time applies only to the first comparison.

In continuous operation, edge detection of the comparator output for interrupts is done by comparing the current and previous sample. The sampling rate is the GCLK\_AC frequency. An example of continuous measurement is shown in the [Figure 46-2](#).

**Figure 46-2. Continuous Measurement Example**



For low-power operation, comparisons can be performed during sleep modes without a clock. The comparator is enabled continuously, and changes of the comparator state are detected asynchronously. When a toggle occurs, the Power Manager will start GCLK\_AC to register the appropriate peripheral events and interrupts. The GCLK\_AC clock is then disabled again automatically, unless configured to wake up the system from sleep.

### 46.6.2.4.2 Single-Shot

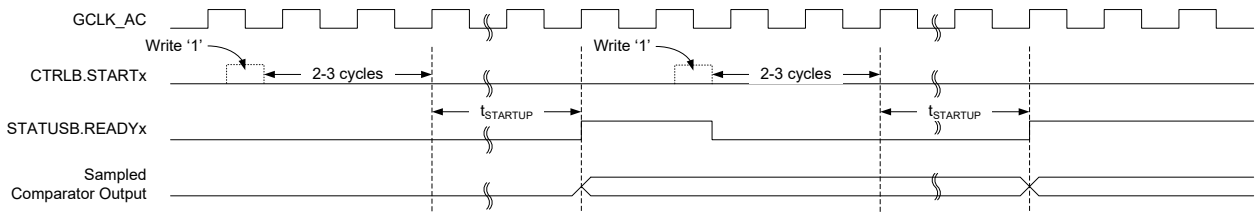
Single-shot operation is selected by writing COMPCTRLx.SINGLE to '1'. During single-shot operation, the comparator is normally idle. The user starts a single comparison by writing '1' to the respective Start Comparison bit in the write-only Control B register (CTRLB.STARTx). The comparator is enabled, and after the start-up time has passed, a single comparison is done and STATUSA is updated. Appropriate peripheral events and interrupts are also generated. No new comparisons will be performed.

Writing '1' to CTRLB.STARTx also clears the Comparator x Ready bit in the Status B register (STATUSB.READYx). STATUSB.READYx is set automatically by hardware when the single comparison has completed.

A single-shot measurement can also be triggered by the Event System. Setting the Comparator x Event Input bit in the Event Control Register (EVCTRL.COMPEIx) enables triggering on incoming peripheral events. Each comparator can be triggered independently by separate events. Event-triggered operation is similar to user-triggered operation; the difference is that a peripheral event from another hardware module causes the hardware to automatically start the comparison and will not clear STATUSB.READYx.

To detect an edge of the comparator output in single-shot operation for the purpose of interrupts, the result of the current measurement is compared with the result of the previous measurement (one sampling period earlier). An example of single-shot operation is shown in [Figure 46-3](#).

**Figure 46-3. Single-Shot Example**



For low-power operation, event-triggered measurements can be performed during sleep modes. When the event occurs, the Power Manager will start GCLK\_AC. The comparator is enabled, and after the startup time has passed, a comparison is done and appropriate peripheral events and interrupts are also generated. The comparator and GCLK\_AC are then disabled again automatically, unless configured to wake up the system from sleep.

### 46.6.3 Selecting Comparator Inputs

Each comparator has one positive and one negative input. The positive input is one of the external input pins (AINx). The negative input can be fed either from an external input pin (AINx) or from one of the several internal reference voltage sources common to all comparators. The user selects the input source as follows:

- The positive input is selected by the Positive Input MUX Select bit group in the Comparator Control register (COMPCTRLx.MUXPOS)
- The negative input is selected by the Negative Input MUX Select bit group in the Comparator Control register (COMPCTRLx.MUXNEG)

In the case of using an external I/O pin, the selected pin must be configured for analog use in the PORT Controller by disabling the digital input and output. The switching of the analog input multiplexers is controlled to minimize crosstalk between the channels. The input selection must be changed only while the individual comparator is disabled.

**Note:** For internal use of the comparison results by the CCL, this bit must be 0x1 or 0x2.

### 46.6.4 Window Operation

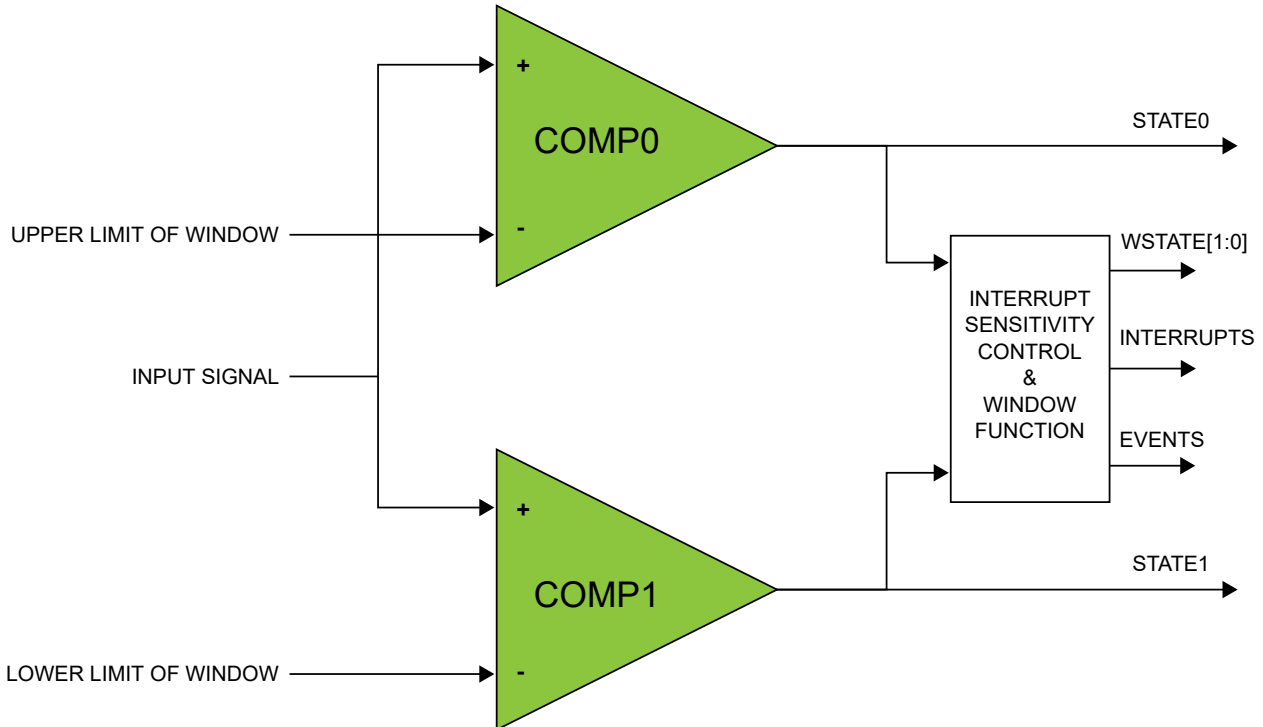
Each comparator pair can be configured to work together in Window mode. In this mode, a voltage range is defined, and the comparators give information about whether an input signal is within this range or not. Window mode is enabled by the Window Enable x bit in the Window Control register (WINCTRL.WENx). Both comparators in a pair must have the same measurement mode setting in their respective Comparator Control Registers (COMPCTRLx.SINGLE).

To physically configure the pair of comparators for Window mode, the same I/O pin must be chosen as positive input for each comparator, providing a shared input signal. The negative inputs define the range for the window. In [Figure 46-4](#), COMP0 defines the upper limit and COMP1 defines the lower limit of the window, as shown but the window will also work in the opposite configuration with COMP0 lower and COMP1 higher. The current state of the window function is available in the Window x State bit group of the Status register (STATUS.WSTATEx).

Window mode can be configured to generate interrupts when the input voltage changes to below the window, when the input voltage changes to above the window, when the input voltage changes into the window or when the input voltage changes outside the window. The interrupt selections are set by the Window Interrupt Selection bit field in the Window Control register (WINCTRL.WINTSEL). Events are generated using the inside/outside state of the window, regardless of whether the interrupt is enabled or not. Note that the individual comparator outputs, interrupts and events continue to function normally during Window mode.

When the comparators are configured for Window mode and Single-shot mode, measurements are performed simultaneously on both comparators. Writing '1' to either Start Comparison bit in the Control B register (CTRLB.STARTx) will start a measurement. Likewise either peripheral event can start a measurement.

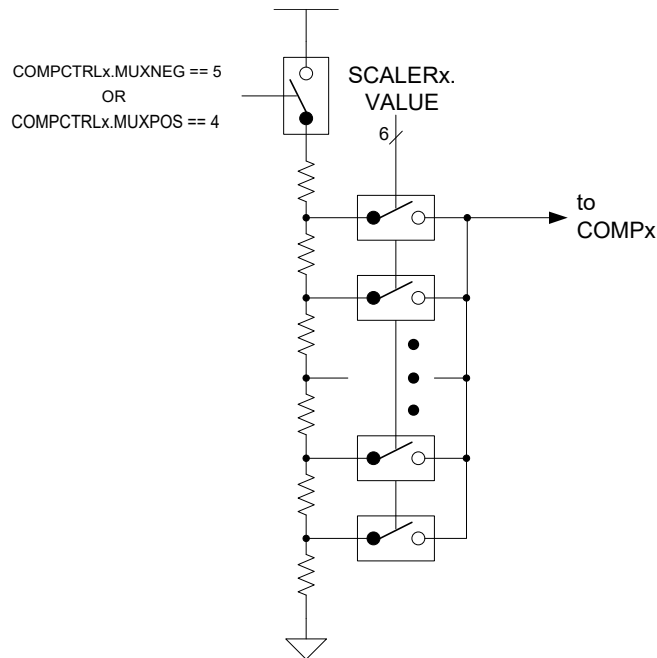
**Figure 46-4. Comparators in Window Mode**



### 46.6.5 VDD Scaler

The VDD scaler generates a reference voltage that is a fraction of the device's supply voltage, with 64 levels. One independent voltage channel is dedicated for each comparator. The scaler of a comparator is enabled when the Negative Input Mux bit field or the Positive Input Mux in the respective Comparator Control register (COMPCTRLx) is set to VSCALE as an input and the comparator is enabled. The voltage of each channel is selected by the Value bit field in the SCALERx registers (SCALERx.VALUE).

**Figure 46-5. VDD Scaler**



### 46.6.6 Input Hysteresis

Application software can selectively enable/disable hysteresis for the comparison. Applying hysteresis will help prevent constant toggling of the output, which can be caused by noise when the input signals are close to each other.

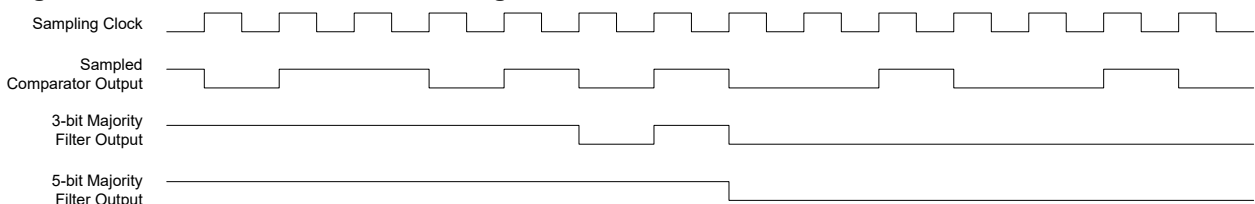
Hysteresis is enabled for each comparator individually by the Hysteresis Enable bit in the Comparator x Control register (COMPCTRLx.HYSTEN). Furthermore, when enabled, the level of hysteresis is programmable through the Hysteresis Level bits also in the Comparator x Control register (COMPCTRLx.HYST). Hysteresis is available only in Continuous mode (COMPCTRLx.SINGLE=0).

### 46.6.7 Filtering

The output of the comparators can be filtered digitally to reduce noise. The filtering is determined by the Filter Length bits in the Comparator Control x register (COMPCTRLx.FLEN), and is independent for each comparator. Filtering is selectable from none, 3-bit majority (N=3) or 5-bit majority (N=5) functions. Any change in the comparator output is considered valid only if  $N/2+1$  out of the last N samples agree. The filter sampling rate is the GCLK\_AC frequency.

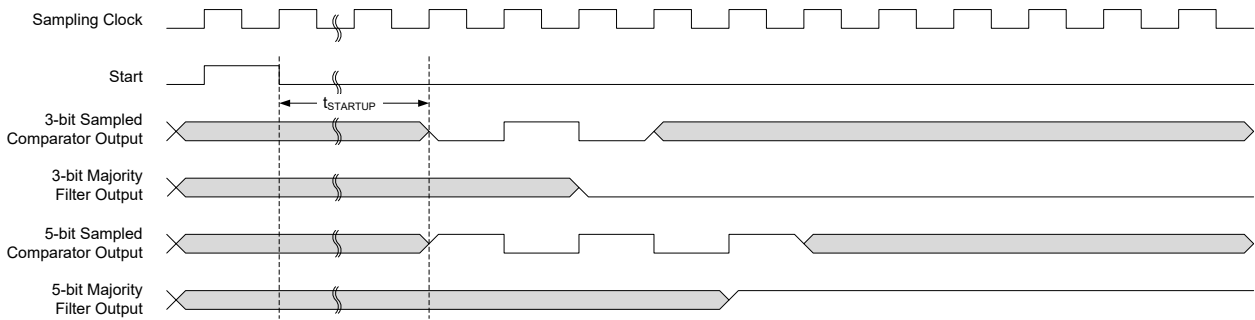
Note that filtering creates an additional delay of N-1 sampling cycles from when a comparison is started until the comparator output is validated. For Continuous mode, the first valid output will occur when the required number of filter samples is taken. Subsequent outputs will be generated every cycle based on the current sample plus the previous N-1 samples, as shown in [Figure 46-6](#). For Single-shot mode, the comparison completes after the Nth filter sample, as shown in [Figure 46-7](#).

**Figure 46-6. Continuous Mode Filtering**





**Figure 46-7. Single-Shot Filtering**



During Sleep modes, filtering is supported only for single-shot measurements. Filtering must be disabled if continuous measurements will be done during Sleep modes, or the resulting interrupt/event may be generated incorrectly.

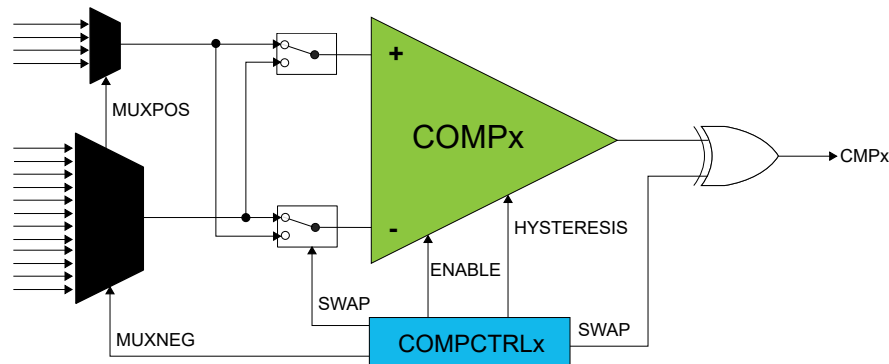
### 46.6.8 Comparator Output

The output of each comparator can be routed to an I/O pin by setting the Output bit group in the Comparator Control x register (COMPCTRLx.OUT). This allows the comparator to be used by external circuitry. Either the raw, non-synchronized output of the comparator or the CLK\_AC-synchronized version, including filtering, can be used as the I/O signal source. The output appears on the corresponding CMP[x] pin.

### 46.6.9 Offset Compensation

The Swap bit in the Comparator Control registers (COMPCTRLx.SWAP) controls switching of the input signals to a comparator's positive and negative terminals. When the comparator terminals are swapped, the output signal from the comparator is also inverted, as shown in Figure 46-8. This allows the user to measure or compensate for the comparator input offset voltage. As part of the input selection, COMPCTRLx.SWAP can be changed only while the comparator is disabled.

**Figure 46-8. Input Swapping for Offset Compensation**



### 46.6.10 DMA Operation

Not applicable.

### 46.6.11 Interrupts

The AC has the following interrupt sources:

- Comparator (COMP0, COMP1): Indicates a change in comparator status.
- Window (WIN0): Indicates a change in the window status.

Comparator interrupts are generated based on the conditions selected by the Interrupt Selection bit group in the Comparator Control registers (COMPCTRLx.INTSEL). Window interrupts are generated based on the conditions selected by the Window Interrupt Selection bit group in the Window Control register (WINCTRL.WINTSEL[1:0]).

Each interrupt source has an interrupt flag associated with it. The interrupt flag in the Interrupt Flag Status and Clear (INTFLAG) register is set when the interrupt condition occurs. Each interrupt can be individually enabled by writing a one to the corresponding bit in the Interrupt Enable Set (INTENSET) register, and disabled by writing a one to the corresponding bit in the Interrupt Enable Clear (INTENCLR) register. An interrupt request is generated when the interrupt flag is set and the corresponding interrupt is enabled. The interrupt request remains active until the interrupt flag is cleared, the interrupt is disabled, or the AC is Reset. See INFLAG register for details on how to clear interrupt flags. All interrupt requests from the peripheral are ORed together on system level to generate one combined interrupt request to the NVIC. The user must read the INTFLAG register to determine which interrupt condition is present.

Note that interrupts must be globally enabled for interrupt requests to be generated.

### Related Links

[10.2 Nested Vector Interrupt Controller](#)

#### 46.6.12 Events

The AC can generate the following output events:

- Comparator (COMP0, COMP1): Generated as a copy of the comparator status
- Window (WIN0): Generated as a copy of the window inside/outside status

Writing a one to an Event Output bit in the Event Control Register (EVCTRL.xxEO) enables the corresponding output event. Writing a zero to this bit disables the corresponding output event. Refer to the Event System chapter for details on configuring the event system.

The AC can take the following action on an input event:

- Start comparison (START0, START1): Start a comparison.

Writing a one to an Event Input bit into the Event Control register (EVCTRL.COMPEIx) enables the corresponding action on input event. Writing a zero to this bit disables the corresponding action on input event. Note that if several events are connected to the AC, the enabled action will be taken on any of the incoming events. Refer to the Event System chapter for details on configuring the event system.

When EVCTRL.COMPEIx is one, the event will start a comparison on COMPx after the start-up time delay. In normal mode, each comparator responds to its corresponding input event independently. For a pair of comparators in window mode, either comparator event will trigger a comparison on both comparators simultaneously.

#### 46.6.13 Sleep Mode Operation

The Run in Standby bits in the Comparator x Control registers (COMPCTRLx.RUNSTDBY) control the behavior of the AC during standby sleep mode. Each RUNSTDBY bit controls one comparator. When the bit is zero, the comparator is disabled during sleep, but maintains its current configuration. When the bit is one, the comparator continues to operate during sleep. Note that when RUNSTDBY is zero, the analog blocks are powered off for the lowest power consumption. This necessitates a start-up time delay when the system returns from sleep.

For Window Mode operation, both comparators in a pair must have the same RUNSTDBY configuration.

When RUNSTDBY is one, any enabled AC interrupt source can wake up the CPU. The AC can also be used during sleep modes where the clock used by the AC is disabled, provided that the AC is still powered (not in shutdown). In this case, the behavior is slightly different and depends on the measurement mode, as listed in [Table 46-2](#).

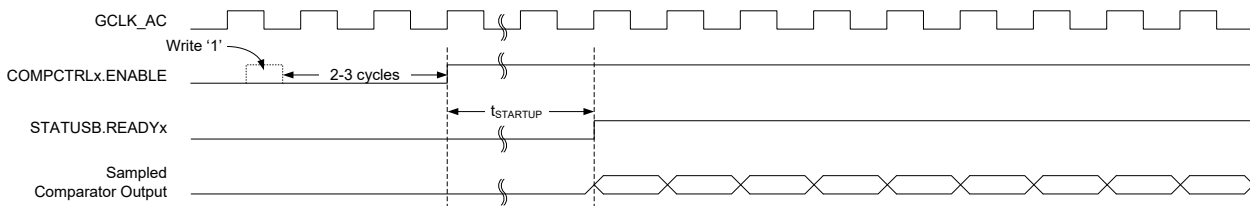
**Table 46-2. Sleep Mode Operation**

COMPCTRLx.MODE	RUNSTDBY=0	RUNSTDBY=1
0 (Continuous)	COMPx disabled	GCLK_AC stopped, COMPx enabled
1 (Single-shot)	COMPx disabled	GCLK_AC stopped, COMPx enabled only when triggered by an input event

### 46.6.13.1 Continuous Measurement during Sleep

When a comparator is enabled in continuous measurement mode and GCLK\_AC is disabled during sleep, the comparator will remain continuously enabled and will function asynchronously. The current state of the comparator is asynchronously monitored for changes. If an edge matching the interrupt condition is found, GCLK\_AC is started to register the interrupt condition and generate events. If the interrupt is enabled in the Interrupt Enable registers (INTENCLR/SET), the AC can wake up the device; otherwise GCLK\_AC is disabled until the next edge detection. Filtering is not possible with this configuration.

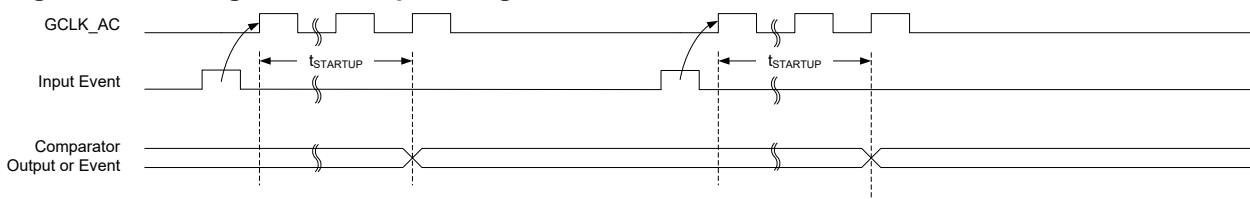
**Figure 46-9. Continuous Mode SleepWalking**



### 46.6.13.2 Single-Shot Measurement during Sleep

For low-power operation, event-triggered measurements can be performed during sleep modes. When the event occurs, the Power Manager will start GCLK\_AC. The comparator is enabled, and after the start-up time has passed, a comparison is done, with filtering if desired, and the appropriate peripheral events and interrupts are also generated, as shown in [Figure 46-10](#). The comparator and GCLK\_AC are then disabled again automatically, unless configured to wake the system from sleep. Filtering is allowed with this configuration.

**Figure 46-10. Single-Shot SleepWalking**



### 46.6.14 Synchronization

Due to asynchronicity between the main clock domain and the peripheral clock domains, some registers need to be synchronized when written or read.

The following bits are synchronized when written:

- Software Reset bit in Control register (CTRLA.SWRST)

# SAM D5x/E5x Family Data Sheet

## AC – Analog Comparators

---

- Enable bit in Control register (CTRLA.ENABLE)
- Enable bit in Comparator Control register (COMPCTRLn.ENABLE)

The following registers are synchronized when written:

- Window Control register (WINCTRL)

Required write synchronization is denoted by the "Write-Synchronized" property in the register description.

### Related Links

[13.3 Register Synchronization](#)

# SAM D5x/E5x Family Data Sheet

## AC – Analog Comparators

### 46.7 Register Summary

Offset	Name	Bit Pos.								
0x00	CTRLA	7:0						ENABLE	SWRST	
0x01	CTRLB	7:0						START1	START0	
0x02	EVCTRL	7:0				WINEO0		COMPEO1	COMPEO0	
		15:8			INVEI1	INVEI0		COMPEI1	COMPEI0	
0x04	INTENCLR	7:0				WIN0		COMP1	COMP0	
0x05	INTENSET	7:0				WIN0		COMP1	COMP0	
0x06	INTFLAG	7:0				WIN0		COMP1	COMP0	
0x07	STATUSA	7:0				WSTATE0[1:0]		STATE1	STATE0	
0x08	STATUSB	7:0						READY1	READY0	
0x09	DBGCTRL	7:0							DBGRUN	
0x0A	WINCTRL	7:0						WINTSEL0[1:0]	WEN0	
0x0B	Reserved									
0x0C	SCALER0	7:0						VALUE[5:0]		
0x0D	SCALER1	7:0						VALUE[5:0]		
0x0E	Reserved									
...										
0x0F										
0x10	COMPCTRL0	7:0		RUNSTDBY		INTSEL[1:0]	SINGLE	ENABLE		
		15:8	SWAP		MUXPOS[2:0]			MUXNEG[2:0]		
		23:16			HYST[1:0]	HYSTEN			SPEED[1:0]	
		31:24			OUT[1:0]				FLEN[2:0]	
0x14	COMPCTRL1	7:0		RUNSTDBY		INTSEL[1:0]	SINGLE	ENABLE		
		15:8	SWAP		MUXPOS[2:0]			MUXNEG[2:0]		
		23:16			HYST[1:0]	HYSTEN			SPEED[1:0]	
		31:24			OUT[1:0]				FLEN[2:0]	
0x18	Reserved									
...										
0x1F										
0x20	SYNDBUSY	7:0				COMPCTRL1	COMPCTRL0	WINCTRL	ENABLE	SWRST
		15:8								
		23:16								
		31:24								
0x24	CALIB	7:0							BIAS0[1:0]	
		15:8								

### 46.8 Register Description

Registers can be 8, 16, or 32 bits wide. Atomic 8-, 16- and 32-bit accesses are supported. In addition, the 8-bit quarters and 16-bit halves of a 32-bit register, and the 8-bit halves of a 16-bit register can be accessed directly.

Some registers are optionally write-protected by the Peripheral Access Controller (PAC). Optional PAC write protection is denoted by the "PAC Write-Protection" property in each individual register description. For details, refer to [Register Access Protection](#).

# SAM D5x/E5x Family Data Sheet

## AC – Analog Comparators

---

---

Some registers are synchronized when read and/or written. Synchronization is denoted by the "Write-Synchronized" or the "Read-Synchronized" property in each individual register description. For details, refer to [Synchronization](#).

Some registers are enable-protected, meaning they can only be written when the peripheral is disabled. Enable-protection is denoted by the "Enable-Protected" property in each individual register description.

### 46.8.1 Control A

**Name:** CTRLA  
**Offset:** 0x00  
**Reset:** 0x00  
**Property:** PAC Write-Protection, Write-Synchronized

	7	6	5	4	3	2	1	0
							ENABLE	SWRST
Access							R/W	W
Reset							0	0

#### Bit 1 – ENABLE Enable

Due to synchronization, there is delay from updating the register until the peripheral is enabled/disabled. The value written to CTRL.ENABLE will read back immediately and the corresponding bit in the Synchronization Busy register (SYNCBUSY.ENABLE) will be set. SYNCBUSY.ENABLE is cleared when the peripheral is enabled/disabled.

Value	Description
0	The AC is disabled.
1	The AC is enabled. Each comparator must also be enabled individually by the Enable bit in the Comparator Control register (COMPCTRLn.ENABLE).

#### Bit 0 – SWRST Software Reset

Writing a '0' to this bit has no effect.

Writing a '1' to this bit resets all registers in the AC to their initial state, and the AC will be disabled.

Writing a '1' to CTRLA.SWRST will always take precedence, meaning that all other writes in the same write-operation will be discarded.

Due to synchronization, there is a delay from writing CTRLA.SWRST until the reset is complete.

CTRLA.SWRST and SYNCBUSY.SWRST will both be cleared when the reset is complete.

Value	Description
0	There is no reset operation ongoing.
1	The reset operation is ongoing.

# SAM D5x/E5x Family Data Sheet

## AC – Analog Comparators

### 46.8.2 Control B

**Name:** CTRLB  
**Offset:** 0x01  
**Reset:** 0x00  
**Property:** -

Bit	7	6	5	4	3	2	1	0
							START1	START0
Access							R/W	R/W
Reset							0	0

#### Bits 0, 1 – STARTx Comparator x Start Comparison

Writing a '0' to this field has no effect.

Writing a '1' to STARTx starts a single-shot comparison on COMPx if both the Single-Shot and Enable bits in the Comparator x Control Register are '1' (COMPCTRLx.SINGLE and COMPCTRLx.ENABLE). If comparator x is not implemented, or if it is not enabled in single-shot mode, Writing a '1' has no effect.

This bit always reads as zero.



# SAM D5x/E5x Family Data Sheet

## AC – Analog Comparators

### 46.8.3 Event Control

**Name:** EVCTRL  
**Offset:** 0x02  
**Reset:** 0x0000  
**Property:** PAC Write-Protection, Enable-Protected

	Bit	15	14	13	12	11	10	9	8
				INVEI1	INVEI0			COMPEI1	COMPEI0
Access				R/W	R/W			R/W	R/W
Reset				0	0			0	0
	Bit	7	6	5	4	3	2	1	0
					WINEO0			COMPEO1	COMPEO0
Access					R/W			R/W	R/W
Reset					0			0	0

#### Bits 12, 13 – INVEIx Inverted Event Input Enable x

Value	Description
0	Incoming event is not inverted for comparator x.
1	Incoming event is inverted for comparator x.

#### Bits 8, 9 – COMPEIx Comparator x Event Input

Note that several actions can be enabled for incoming events. If several events are connected to the peripheral, the enabled action will be taken for any of the incoming events. There is no way to tell which of the incoming events caused the action.

These bits indicate whether a comparison will start or not on any incoming event.

Value	Description
0	Comparison will not start on any incoming event.
1	Comparison will start on any incoming event.

#### Bit 4 – WINEO0 Window 0 Event Output Enable

These bits indicate whether the window 0 function can generate a peripheral event or not.

Value	Description
0	Window 0 Event is disabled.
1	Window 0 Event is enabled.

#### Bits 0, 1 – COMPEOx Comparator x Event Output Enable

These bits indicate whether the comparator x output can generate a peripheral event or not.

Value	Description
0	COMPx event generation is disabled.
1	COMPx event generation is enabled.

### 46.8.4 Interrupt Enable Clear

**Name:** INTENCLR  
**Offset:** 0x04  
**Reset:** 0x00  
**Property:** PAC Write-Protection

This register allows the user to disable an interrupt without doing a read-modify-write operation. Changes in this register will also be reflected in the Interrupt Enable Set register (INTENSET).

	7	6	5	4	3	2	1	0
				WIN0			COMP1	COMP0
Access				R/W			R/W	R/W
Reset				0			0	0

**Bit 4 – WIN0** Window 0 Interrupt Enable

Reading this bit returns the state of the Window 0 interrupt enable.

Writing a '0' to this bit has no effect.

Writing a '1' to this bit disables the Window 0 interrupt.

Value	Description
0	The Window 0 interrupt is disabled.
1	The Window 0 interrupt is enabled.

**Bits 0, 1 – COMPx** Comparator x Interrupt Enable

Reading this bit returns the state of the Comparator x interrupt enable.

Writing a '0' to this bit has no effect.

Writing a '1' to this bit disables the Comparator x interrupt.

Value	Description
0	The Comparator x interrupt is disabled.
1	The Comparator x interrupt is enabled.

### 46.8.5 Interrupt Enable Set

**Name:** INTENSET  
**Offset:** 0x05  
**Reset:** 0x00  
**Property:** PAC Write-Protection

This register allows the user to enable an interrupt without doing a read-modify-write operation. Changes in this register will also be reflected in the Interrupt Enable Clear register (INTENCLR).

	7	6	5	4	3	2	1	0
				WIN0			COMP1	COMP0
Access				R/W			R/W	R/W
Reset				0			0	0

**Bit 4 – WIN0** Window 0 Interrupt Enable

Reading this bit returns the state of the Window 0 interrupt enable.

Writing a '0' to this bit has no effect.

Writing a '1' to this bit enables the Window 0 interrupt.

Value	Description
0	The Window 0 interrupt is disabled.
1	The Window 0 interrupt is enabled.

**Bits 0, 1 – COMPx** Comparator x Interrupt Enable

Reading this bit returns the state of the Comparator x interrupt enable.

Writing a '0' to this bit has no effect.

Writing a '1' to this bit will set the Ready interrupt bit and enable the Ready interrupt.

Value	Description
0	The Comparator x interrupt is disabled.
1	The Comparator x interrupt is enabled.

### 46.8.6 Interrupt Flag Status and Clear

**Name:** INTFLAG  
**Offset:** 0x06  
**Reset:** 0x00  
**Property:** –

	7	6	5	4	3	2	1	0
				WIN0			COMP1	COMP0
Access				R/W			R/W	R/W
Reset				0			0	0

**Bit 4 – WIN0** Window 0

This flag is set according to the Window 0 Interrupt Selection bit group in the [WINCTRL](#) register (WINCTRL.WINTSELx) and will generate an interrupt if INTENCLR/SET.WINx is also one.

Writing a '0' to this bit has no effect.

Writing a '1' to this bit clears the Window 0 interrupt flag.

**Bits 0, 1 – COMPx** Comparator x

Reading this bit returns the status of the Comparator x interrupt flag. If comparator x is not implemented, COMPx always reads as zero.

This flag is set according to the Interrupt Selection bit group in the Comparator x Control register (COMPCTRLx.INTSEL) and will generate an interrupt if INTENCLR/SET.COMPx is also one.

Writing a '0' to this bit has no effect.

Writing a '1' to this bit clears the Comparator x interrupt flag.

# SAM D5x/E5x Family Data Sheet

## AC – Analog Comparators

### 46.8.7 Status A

**Name:** STATUSA  
**Offset:** 0x07  
**Reset:** 0x00  
**Property:** -

	Bit	7	6	5	4	3	2	1	0
				WSTATE0[1:0]				STATE1	STATE0
Access				R	R			R	R
Reset				0	0			0	0

#### Bits 5:4 – WSTATE0[1:0] Window 0 Current State

These bits show the current state of the signal if the window 0 mode is enabled. These values may change in during startup and measurement cycles. When polling for sample completion use the STATUSB.READY bit to signal completion.

Value	Name	Description
0x0	ABOVE	Signal is above window
0x1	INSIDE	Signal is inside window
0x2	BELOW	Signal is below window
0x3		Reserved

#### Bits 0, 1 – STATEx Comparator x Current State

This bit shows the current state of the output signal from COMPx. STATEx is valid only when STATUSB.READYx is one.

# SAM D5x/E5x Family Data Sheet

## AC – Analog Comparators

### 46.8.8 Status B

**Name:** STATUSB  
**Offset:** 0x08  
**Reset:** 0x00  
**Property:** -

Bit	7	6	5	4	3	2	1	0
							READY1	READY0
Access							R	R
Reset							0	0

#### **Bits 0, 1 – READYx** Comparator x Ready

This bit is cleared when the comparator x output is not ready.

This bit is set when the comparator x output is ready.

# SAM D5x/E5x Family Data Sheet

## AC – Analog Comparators

### 46.8.9 Debug Control

**Name:** DBGCTRL  
**Offset:** 0x09  
**Reset:** 0x00  
**Property:** PAC Write-Protection

Bit	7	6	5	4	3	2	1	0
								DBGRUN
Access								R/W
Reset								0

#### Bit 0 – DBGRUN Debug Run

This bit is not reset by a software reset.

This bit controls the functionality when the CPU is halted by an external debugger.

Value	Description
0	The AC is halted when the CPU is halted by an external debugger. Any on-going comparison will complete.
1	The AC continues normal operation when the CPU is halted by an external debugger.

# SAM D5x/E5x Family Data Sheet

## AC – Analog Comparators

### 46.8.10 Window Control

**Name:** WINCTRL  
**Offset:** 0x0A  
**Reset:** 0x00  
**Property:** PAC Write-Protection, Write-Synchronized

	7	6	5	4	3	2	1	0
						WINTSEL0[1:0]		WEN0
Access						R/W	R/W	R/W
Reset						0	0	0

#### Bits 2:1 – WINTSEL0[1:0] Window 0 Interrupt Selection

These bits configure the interrupt mode for the comparator window 0 mode.

Value	Name	Description
0x0	ABOVE	Interrupt on signal above window
0x1	INSIDE	Interrupt on signal inside window
0x2	BELOW	Interrupt on signal below window
0x3	OUTSIDE	Interrupt on signal outside window

#### Bit 0 – WEN0 Window 0 Mode Enable

Value	Description
0	Window mode is disabled for comparators 0 and 1.
1	Window mode is enabled for comparators 0 and 1.



# SAM D5x/E5x Family Data Sheet

## AC – Analog Comparators

### 46.8.11 Scaler n

**Name:** SCALER  
**Offset:** 0x0C + n\*0x01 [n=0..1]  
**Reset:** 0x00  
**Property:** PAC Write-Protection

	7	6	5	4	3	2	1	0
			VALUE[5:0]					
Access			R/W	R/W	R/W	R/W	R/W	R/W
Reset			0	0	0	0	0	0

#### Bits 5:0 – VALUE[5:0] Scaler Value

These bits define the scaling factor for channel n of the  $V_{DD}$  voltage scaler. The output voltage,  $V_{SCALE}$ , is:

$$V_{SCALE} = \frac{V_{DD} \cdot (VALUE+1)}{64}$$

# SAM D5x/E5x Family Data Sheet

## AC – Analog Comparators

### 46.8.12 Comparator Control n

**Name:** COMPCTRL  
**Offset:** 0x10 + n\*0x04 [n=0..1]  
**Reset:** 0x00000000  
**Property:** PAC Write-Protection

	Bit	31	30	29	28	27	26	25	24
				OUT[1:0]			FLEN[2:0]		
Access				R/W	R/W		R/W	R/W	R/W
Reset				0	0		0	0	0
	Bit	23	22	21	20	19	18	17	16
				HYST[1:0]		HYSTEN		SPEED[1:0]	
Access				R/W	R/W	R/W		R/W	R/W
Reset				0	0	0		0	0
	Bit	15	14	13	12	11	10	9	8
		SWAP	MUXPOS[2:0]				MUXNEG[2:0]		
Access		R/W	R/W	R/W	R/W		R/W	R/W	R/W
Reset		0	0	0	0		0	0	0
	Bit	7	6	5	4	3	2	1	0
			RUNSTDBY		INTSEL[1:0]		SINGLE	ENABLE	
Access			R/W		R/W	R/W	R/W	R/W	
Reset			0		0	0	0	0	

#### Bits 29:28 – OUT[1:0] Output

These bits configure the output selection for comparator n. COMPCTRLn.OUT can be written only while COMPCTRLn.ENABLE is zero.

**Note:** For internal use of the comparison results by the CCL, this bit must be 0x1 or 0x2.

These bits are not synchronized.

Value	Name	Description
0x0	OFF	The output of COMPn is not routed to the COMPn I/O port
0x1	ASYNC	The asynchronous output of COMPn is routed to the COMPn I/O port
0x2	SYNC	The synchronous output (including filtering) of COMPn is routed to the COMPn I/O port
0x3	N/A	Reserved

#### Bits 26:24 – FLEN[2:0] Filter Length

These bits configure the filtering for comparator n. COMPCTRLn.FLEN can only be written while COMPCTRLn.ENABLE is zero.

These bits are not synchronized.

Value	Name	Description
0x0	OFF	No filtering
0x1	MAJ3	3-bit majority function (2 of 3)
0x2	MAJ5	5-bit majority function (3 of 5)
0x3–0x7	N/A	Reserved

### Bits 21:20 – HYST[1:0] Hysteresis Level

These bits indicate the hysteresis level of comparator n when hysteresis is enabled (COMPCTRLn.HYSTEN=1). Hysteresis is available only for continuous mode (COMPCTRLn.SINGLE=0). COMPCTRLn.HYST can be written only while COMPCTRLn.ENABLE is zero.

These bits are not synchronized.

Value	Name	Description
0x0	HYST50	50mV
0x1	HYST100	100mV
0x2	HYST150	150mV
0x3	N/A	Reserved

### Bit 19 – HYSTEN Hysteresis Enable

This bit indicates the hysteresis mode of comparator n. Hysteresis is available only for continuous mode (COMPCTRLn.SINGLE=0).

This bit is not synchronized.

Value	Description
0	Hysteresis is disabled.
1	Hysteresis is enabled.

### Bits 17:16 – SPEED[1:0] Speed Selection

This bit must be written to 0x3 for each comparator n. COMPCTRLn.SPEED can be written only while COMPCTRLn.ENABLE is zero.

These bits are not synchronized.

Value	Name	Description
0x3	HIGH	High speed
Other	-	Reserved

### Bit 15 – SWAP Swap Inputs and Invert

This bit swaps the positive and negative inputs to COMPn and inverts the output. This function can be used for offset cancellation. COMPCTRLn.SWAP can be written only while COMPCTRLn.ENABLE is zero.

These bits are not synchronized.

Value	Description
0	The output of MUXPOS connects to the positive input, and the output of MUXNEG connects to the negative input.
1	The output of MUXNEG connects to the positive input, and the output of MUXPOS connects to the negative input.

### Bits 14:12 – MUXPOS[2:0] Positive Input Mux Selection

These bits select which input will be connected to the positive input of comparator n.

COMPCTRLn.MUXPOS can be written only while COMPCTRLn.ENABLE is zero.

These bits are not synchronized.

Value	Name	Description
0x0	PIN0	I/O pin 0
0x1	PIN1	I/O pin 1
0x2	PIN2	I/O pin 2
0x3	PIN3	I/O pin 3
0x4	VSCALE	VDD scaler
0x5–0x7	-	Reserved

### Bits 10:8 – MUXNEG[2:0] Negative Input Mux Selection

These bits select which input will be connected to the negative input of comparator n.

COMPCTRLn.MUXNEG can only be written while COMPCTRLn.ENABLE is zero.

These bits are not synchronized.

Value	Name	Description
0x0	PIN0	I/O pin 0
0x1	PIN1	I/O pin 1
0x2	PIN2	I/O pin 2
0x3	PIN3	I/O pin 3
0x4	GND	Ground
0x5	VSCALE	VDD scaler
0x6	BANDGAP	Internal bandgap voltage
0x7	DAC	DAC output

### Bit 6 – RUNSTDBY Run in Standby

This bit controls the behavior of the comparator during standby sleep mode.

This bit is not synchronized

Value	Description
0	The comparator is disabled during sleep.
1	The comparator continues to operate during sleep.

### Bits 4:3 – INTSEL[1:0] Interrupt Selection

These bits select the condition for comparator n to generate an interrupt or event. COMPCTRLn.INTSEL can be written only while COMPCTRLn.ENABLE is zero.

These bits are not synchronized.

Value	Name	Description
0x0	TOGGLE	Interrupt on comparator output toggle
0x1	RISING	Interrupt on comparator output rising
0x2	FALLING	Interrupt on comparator output falling
0x3	EOC	Interrupt on end of comparison (single-shot mode only)

### Bit 2 – SINGLE Single-Shot Mode

This bit determines the operation of comparator n. COMPCTRLn.SINGLE can be written only while COMPCTRLn.ENABLE is zero.

These bits are not synchronized.

Value	Description
0	Comparator n operates in continuous measurement mode.
1	Comparator n operates in single-shot mode.

### Bit 1 – ENABLE Enable

Writing a zero to this bit disables comparator n.

Writing a one to this bit enables comparator n.

Due to synchronization, there is delay from updating the register until the comparator is enabled/disabled.

The value written to COMPCTRLn.ENABLE will read back immediately after being written.

SYNCBUSY.COMPCTRLn is set. SYNCBUSY.COMPCTRLn is cleared when the peripheral is enabled/disabled.

Writing a one to COMPCTRLn.ENABLE will prevent further changes to the other bits in COMPCTRLn.

These bits remain protected until COMPCTRLn.ENABLE is written to zero and the write is synchronized.

# SAM D5x/E5x Family Data Sheet

## AC – Analog Comparators

### 46.8.13 Synchronization Busy

**Name:** SYNCBUSY  
**Offset:** 0x20  
**Reset:** 0x00000000  
**Property:** -

	31	30	29	28	27	26	25	24
Access								
Reset								
	23	22	21	20	19	18	17	16
Access								
Reset								
	15	14	13	12	11	10	9	8
Access								
Reset								
	7	6	5	4	3	2	1	0
				COMPCTRL1	COMPCTRL0	WINCTRL	ENABLE	SWRST
Access				R	R	R	R	R
Reset				0	0	0	0	0

**Bits 3, 4 – COMPCTRLx** COMPCTRLx Synchronization Busy

This bit is cleared when the synchronization of the COMPCTRLx register between the clock domains is complete.

This bit is set when the synchronization of the COMPCTRLx register between clock domains is started.

**Bit 2 – WINCTRL** WINCTRL Synchronization Busy

This bit is cleared when the synchronization of the WINCTRL register between the clock domains is complete.

This bit is set when the synchronization of the WINCTRL register between clock domains is started.

**Bit 1 – ENABLE** Enable Synchronization Busy

This bit is cleared when the synchronization of the CTRLA.ENABLE bit between the clock domains is complete.

This bit is set when the synchronization of the CTRLA.ENABLE bit between clock domains is started.

**Bit 0 – SWRST** Software Reset Synchronization Busy

This bit is cleared when the synchronization of the CTRLA.SWRST bit between the clock domains is complete.

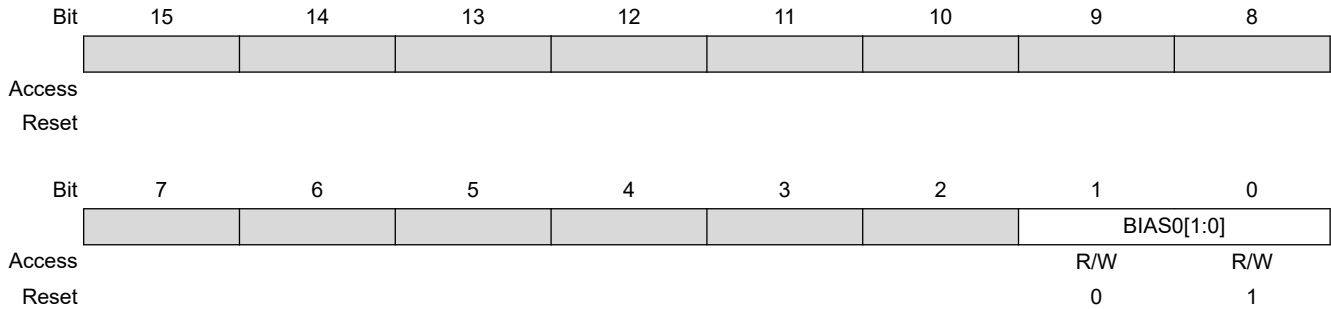
This bit is set when the synchronization of the CTRLA.SWRST bit between clock domains is started.

# SAM D5x/E5x Family Data Sheet

## AC – Analog Comparators

### 46.8.14 Calibration Register

**Name:** CALIB  
**Offset:** 0x24  
**Reset:** 0x0101  
**Property:** Enable-Protect, PAC Write-Protection



**Bits 1:0 – BIAS0[1:0]** COMP0/1 Bias Scaling

This value from production test must be loaded from the NVM software calibration row into the CALIB register by software to achieve the specified accuracy. The value must be copied only, and must not be changed

## 47. DAC – Digital-to-Analog Converter

### 47.1 Overview

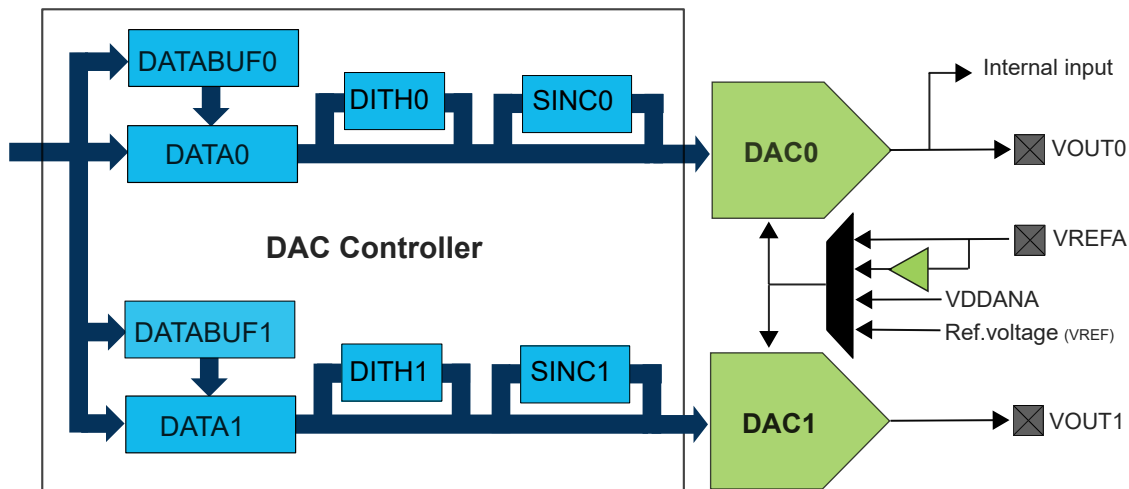
The Digital-to-Analog Converter (DAC) converts a digital value to a voltage. The DAC Controller controls two DACs, which can operate either as two independent DACs or as a single DAC in differential mode. Each DAC is 12-bit resolution and is capable of converting up to 1,000,000 samples per second (MSPS).

### 47.2 Features

- Two independent DACs or single DAC in differential mode
- DAC with 12-bit resolution
- Integrated or Standalone filters with 2x, 4x, 8x, 16x, or 32x oversampling rate (OSR)
- Up to 1MSPS conversion rate
- Hardware support for 16-bit using dithering
- Multiple trigger sources
- High-drive capabilities
- DAC0 used as internal input
- DMA support

### 47.3 Block Diagram

Figure 47-1. DAC Controller Block Diagram



### 47.4 Signal Description

Signal	Description	Type
VOUT0	DAC0 output	Analog output
VOUT1	DAC1 output	Analog output

# SAM D5x/E5x Family Data Sheet

## DAC – Digital-to-Analog Converter

.....continued

Signal	Description	Type
VREFA	External reference	Analog input

One signal can be mapped on several pins.



### Important:

When an analog peripheral is enabled, the analog output of the peripheral will interfere with the alternative functions of the output pads. This is also true even when the peripheral is used for internal purposes.

Analog inputs do not interfere with alternative pad functions.

### Related Links

[6. I/O Multiplexing and Considerations](#)

## 47.5 Product Dependencies

In order to use this peripheral, other parts of the system must be configured correctly, as described below.

### 47.5.1 I/O Lines

Using the DAC Controller's I/O lines requires the I/O pins to be configured in the PORT - I/O Pin Controller.

**Table 47-1. I/O Lines**

Instance	Signal	Peripheral Function
DAC	VOUT0	A
DAC	VOUT1	A
DAC	VREFA	A

### 47.5.2 Power Management

The DAC Controller will continue to operate in any sleep mode where the selected source clock is running.

The DAC Controller interrupts can be used to wake up the device from sleep modes.

Events connected to the event system can trigger other operations in the system without exiting sleep modes.

### Related Links

[18. PM – Power Manager](#)

### 47.5.3 Clocks

The DAC bus clock (CLK\_DAC\_APB) can be enabled and disabled in the Main Clock module, and the default state of CLK\_DAC\_APB can be found in *Peripheral Clock Masking*.

A generic clock (GCLK\_DAC) is required to clock the DAC Controller. This clock must be configured and enabled in the generic clock controller before using the DAC Controller.



This generic clock is asynchronous to the bus clock (CLK\_DAC\_APB). Due to this asynchronicity, writes to certain registers will require synchronization between the clock domains. Refer to [47.6.8 Synchronization](#) for further details.

### Related Links

[15.6.2.6 Peripheral Clock Masking](#)

[14. GCLK - Generic Clock Controller](#)

#### 47.5.4 DMA

The DMA request line is connected to the DMA Controller (DMAC). Using the DAC Controller DMA requests requires to configure the DMAC first.

### Related Links

[22. DMAC – Direct Memory Access Controller](#)

#### 47.5.5 Interrupts

The interrupt request line is connected to the interrupt controller. Using the DAC Controller interrupts requires the interrupt controller to be configured first.

### Related Links

[10.2 Nested Vector Interrupt Controller](#)

[10.2 Nested Vector Interrupt Controller](#)

#### 47.5.6 Events

The events are connected to the Event System.

### Related Links

[31. EVSYS – Event System](#)

#### 47.5.7 Debug Operation

When the CPU is halted in debug mode the DAC will halt normal operation. Any on-going conversions will be completed. The DAC can be forced to continue normal operation during debugging. If the DAC is configured in a way that requires it to be periodically serviced by the CPU through interrupts or similar, improper operation or data loss may result during debugging.

### Related Links

[47.8.15 DBGCTRL](#)

#### 47.5.8 Register Access Protection

All registers with write access can be write-protected optionally by the Peripheral Access Controller (PAC), except for the following registers:

- Interrupt Flag Status and Clear (INTFLAG) register
- Data Buffer (DATABUFx) registers

Optional write protection by the Peripheral Access Controller (PAC) is denoted by the "PAC Write Protection" property in each individual register description.

PAC write protection does not apply to accesses through an external debugger.

### Related Links

[27. PAC - Peripheral Access Controller](#)

### 47.5.9 Analog Connections

The DAC has up to two analog output pins (VOUT0, VOUT1) and one analog input pin (VREFA) that must be configured first.

When an internal input is used, it must be enabled before DAC Controller is enabled.

The analog signals of AC, ADC, DAC and OPAMP can be interconnected.

See *Analog Connections of Peripherals* for details.

## 47.6 Functional Description

### 47.6.1 Principle of Operation

Each DAC converts the digital value located in the Data register (DATA0 or DATA1) into an analog voltage on the DAC output (VOUT0 or VOUT1, respectively).

A conversion is started when new data is loaded to the Data register. The resulting voltage is available on the DAC output after the conversion time. A conversion can also be started by input events from Event System.

### 47.6.2 Basic Operation

#### 47.6.2.1 Initialization

The following registers are enable-protected, meaning they can only be written when the DAC Controller is disabled (CTRLA.ENABLE=0):

- Control B register (CTRLB)
- Event Control register (EVCTRL)
- DAC0 Control (DACCTRL0)
- DAC1 Control (DACCTRL1)

Enable-protection is denoted by the Enable-Protected property in the register description.

#### 47.6.2.2 Enabling, Disabling and Resetting

The DAC Controller is enabled by writing a '1' to the Enable bit in the Control A register (CTRLA.ENABLE). The DAC Controller is disabled by writing a '0' to CTRLA.ENABLE.

The DAC Controller is reset by writing '1' to the Software Reset bit in the Control A register (CTRLA.SWRST). All registers in the DAC will be reset to their initial state, and the DAC Controller will be disabled. Refer to [47.8.1 CTRLA](#) for details.

#### 47.6.2.3 DAC Configuration

Each individual DAC is configured by its respective DAC Control register (DACCTRLx). These settings are applied when DAC Controller is enabled and can be changed only when DAC Controller is disabled.

- Enable the selected DAC by writing a '1' to DACCTRLx.ENABLE.
- Select the data alignment with DACCTRLx.LEFTADJ. Writing a '1' will left-align the data (DATABUFx/DATAx[31:20]). Writing a '0' to LEFTADJ will right-align the data (DATABUFx/DATAx[11:0]).
- If operation in standby mode is desired for DACx, write a '1' to the Run in Standby bit in the DAC Control register (DACCTRLx.RUNSTDBY). If RUNSTDBY=1, DACx continues normal operation when system is in standby mode. If RUNSTDBY=0, DACx is halted in standby mode.
- Select dithering mode with DACCTRLx.DITHER. Writing '1' to DITHER will enable dithering mode, writing a '0' will disable it. Refer to [47.6.9.5 Dithering Mode](#) for details.

- Select the refresh period with the Refresh Period bit field in DACCTRLx.REFRESH[3:0]. Writing any value greater than '1' to the REFRESH bit field will enable and select the refresh mode. Refer to [47.6.9.3 Conversion Refresh](#) for details.
- Select the output buffer current according to data rate (for low power application) with the Current Control bit field DACCTRLx.CCTRL[1:0]. Refer to [47.6.9.2 Output Buffer Current Control](#) for details.
- Select standalone filter usage by writing to DACCTRLx.FEXT. Writing FEXT=1 selects a standalone filter, FEXT=0 selects the filter integrated to the DAC. See also [47.6.9.6 Interpolation Mode](#) for details.
- Select the filter oversampling ratio by writing to DACCTRLx.OSR[2:0]. writing OSR=0 selects no oversampling; writing any other value will enable interpolation of input data. See also [47.6.9.6 Interpolation Mode](#) for details.

Once the DAC Controller is enabled, DACx requires a startup time before the first conversion can start. The DACx Startup Ready bit in the Status register (STATUS.READYx) indicates that DACx is ready to convert a data when STATUS.READYx=1.

Conversions started while STATUS.READYx=0 shall be discarded.

VOUTx is at tri-state level if DACx is not enabled.

#### 47.6.2.4 Digital to Analog Conversion

Each DAC converts a digital value (stored in DATAx register) into an analog voltage. The conversion range is between GND and the selected DAC voltage reference VREF. The default source for VREF is the internal reference voltage VREF. Other voltage reference options are the analog supply voltage (VDDANA) and the external voltage reference (VREFA). The voltage reference is selected by writing to the Reference Selection bits in the Control B register (CTRLB.REFSEL).

The output voltage from the DAC can be calculated using the following formula:

$$V_{OUTx} = \frac{DATAx}{4095} \times VREF$$

A new conversion starts as soon as a new value is loaded into DATAx. DATAx can either be loaded via the APB bus during a CPU write operation, using DMA, or from the DATABUFx register when a STARTx event occurs.

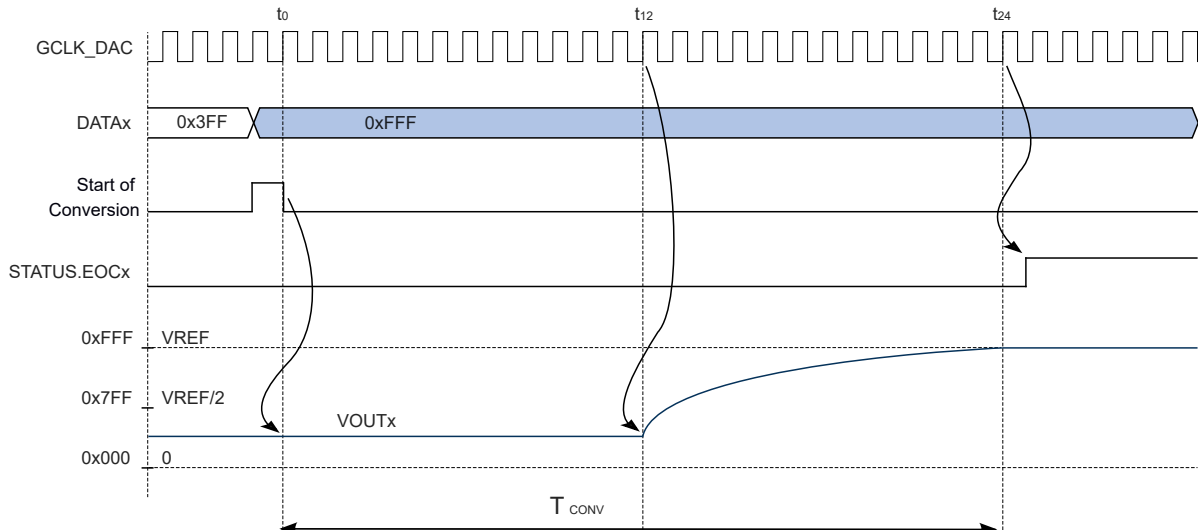
Refer to [47.5.6 Events](#) for details. Even if both DAC use the same GCLK, each data conversion can be started independently.

The conversion time is given by the period  $T_{GCLK}$  of the generic clock GCLK\_DAC and the number of bits:

$$T_{CONV} = 12 \times 2 \times T_{GCLK}$$

The End Of Conversion bit in the Status register indicates that a conversion is completed (STATUS.EOCx=1). This means that VOUTx is stable.

**Figure 47-2. Single DAC Conversion**

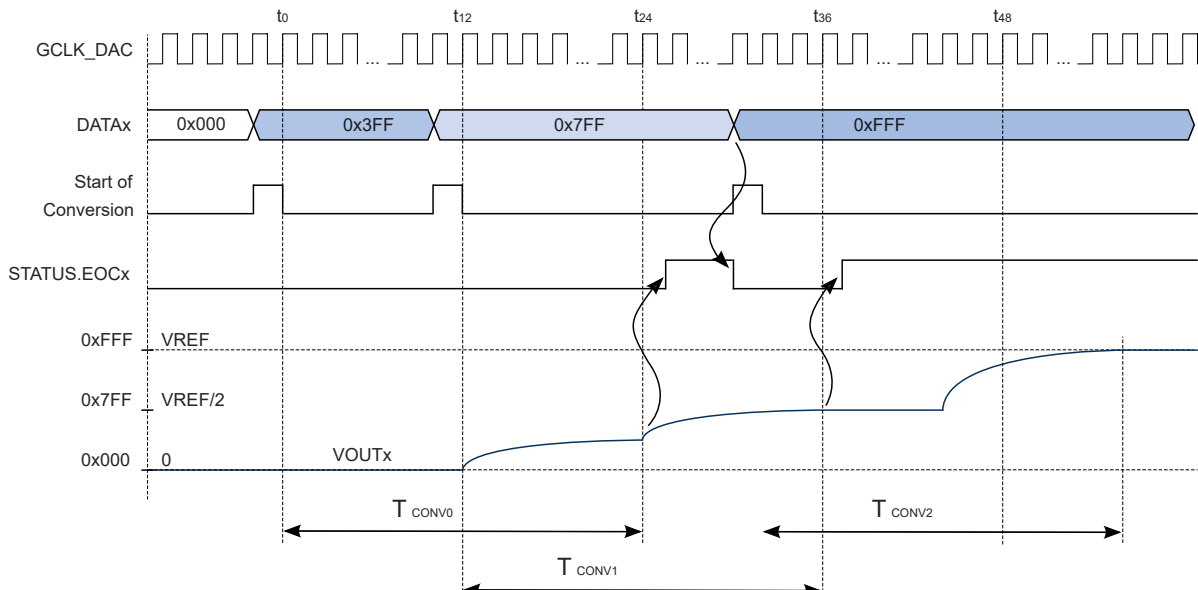


Since the DAC conversion is implemented as pipelined procedure, a new conversion can be started after only 12 GCLK\_DAC periods. Therefore if DATAx is written while a conversion is ongoing, start of conversion is postponed until DACx is ready to start next conversion.

The maximum conversion rate (samples per second) is therefore:

$$CR_{\max} = \frac{2}{T_{\text{conv}}}$$

**Figure 47-3. Multiple DAC Conversions**



### Related Links

[19. SUPC – Supply Controller](#)

### 47.6.3 Operating Conditions

- The DAC voltage reference must be below VDDANA.
- The maximum conversion rate of 1MSPS can be achieved only if VDDANA is above 2.4V.

- The frequency of GCLK\_DAC must be equal or lower than 12MHz (corresponding to 1MSPS).

### 47.6.4 DMA Operation

In single mode (CTRLB.DIFF=0), DAC Controller generates the following DMA requests:

- Data Buffer 0 Empty (EMPTY0): The request is set when data is transferred from DATABUF0 or DATA0 to the internal data buffer of DAC0. The request is cleared when either DATA0 register or DATABUF0 register is written, or by writing a '1' to the EMPTY0 bit in the Interrupt Flag register (INTFLAG.EMPTY0).
- Data Buffer 1 Empty (EMPTY1): The request is set when data is transferred from DATABUF1 or DATA1 to the internal data buffer of DAC1. The request is cleared when either DATA0 register or DATABUF1 register is written, or by writing a one to the EMPTY1 bit in the Interrupt Flag register (INTFLAG.EMPTY1).
- Filter 0 Result Ready (RESRDY0): The request is set when the filter is used as standalone, and filter output is ready. The request is cleared by writing a '1' to the RESRDY0 bit in the Interrupt Flag register (INTFLAG.RESRDY0).
- Filter 1 Result Ready (RESRDY1): The request is set when the filter is used as standalone, and filter output is ready. The request is cleared by writing a '1' to the RESRDY1 bit in the Interrupt Flag register (INTFLAG.RESRDY1).

In differential mode (CTRLB.DIFF=1), DAC Controller generates the following DMA request:

- Data Buffer 0 Empty (EMPTY0): The request is set when data is transferred from DATABUF0 or DATA0 to the internal data buffer of DAC1. The request is cleared when either DATA0 register or DATABUF0 register is written, or by writing a one to the EMPTY0 bit in the Interrupt Flag register (INTFLAG.EMPTY0).

If the CPU accesses the registers which are source of DMA request set/clear condition, the DMA request can be lost or the DMA transfer can be corrupted, if enabled.

### 47.6.5 Interrupts

The DAC Controller has the following interrupt sources:

- DAC0 Data Buffer Empty (EMPTY0): Indicates that the internal data buffer of DAC0 is empty.
- DAC1 Data Buffer Empty (EMPTY1): Indicates that the internal data buffer of DAC1 is empty.
- DAC0 Underrun (UNDERRUN0): Indicates that the internal data buffer of DAC0 is empty and a DAC0 start of conversion event occurred. Refer to [47.5.6 Events](#) for details.
- DAC1 Underrun (UNDERRUN1): Indicates that the internal data buffer of DAC1 is empty and a DAC1 start of conversion event occurred. Refer to [47.5.6 Events](#) for details.
- Filter 0 Result Ready (RESRDY0): Indicates that Filter 0 result is ready if set as standalone filter.
- Filter 1 Result Ready (RESRDY1): Indicates that Filter 1 result is ready if set as standalone filter.
- Filter 0 Overrun (OVERRUN0): Indicates that the DMA request has not been cleared while the RESULT0 register gets new data.
- Filter 1 Overrun (OVERRUN1): Indicates that the DMA request has not been cleared while the RESULT1 register gets new data.

These interrupts are asynchronous wake-up sources.

Each interrupt source has an interrupt flag associated with it. The interrupt flag in the Interrupt Flag Status and Clear (INTFLAG) register is set when the interrupt condition occurs. Each interrupt can be individually enabled by writing a '1' to the corresponding bit in the Interrupt Enable Set (INTENSET)

register, and disabled by writing a '1' to the corresponding bit in the Interrupt Enable Clear (INTENCLR) register.

An interrupt request is generated when the interrupt flag is set and the corresponding interrupt is enabled. The interrupt request remains active until the interrupt flag is cleared, the interrupt is disabled, or the DAC Controller is reset. See [47.8.6 INTFLAG](#) for details on how to clear interrupt flags.

All interrupt requests from the peripheral are ORed together on system level to generate one combined interrupt request to the NVIC. The user must read the INTFLAG register to determine which interrupt condition is present.

Note that interrupts must be globally enabled for interrupt requests to be generated.

### 47.6.6 Events

The DAC Controller can generate the following output events:

- Data Buffer 0 Empty (EMPTY0): Generated when the internal data buffer of DAC0 is empty. Refer to [47.6.4 DMA Operation](#) for details.
- Data Buffer 1 Empty (EMPTY1): Generated when the internal data buffer of DAC1 is empty. Refer to [47.6.4 DMA Operation](#) for details.
- Filter 0 Result Ready (RESRDY0): Generated when standalone filter 0 result is ready.
- Filter 1 Result Ready (RESRDY1): Generated when standalone filter 1 result is ready.

Writing a '1' to an Event Output bit in the Event Control Register (EVCTRL.EMPTYEOx) enables the corresponding output event. Writing a '0' to this bit disables the corresponding output event. Refer to the Event System chapter for details on configuring the event system.

The DAC Controller can take the following actions on an input event:

- DAC0 Start Conversion (START0): DATABUF0 value is transferred into DATA0 as soon as DAC0 is ready for the next conversion, and then conversion is started. START0 is considered as asynchronous to GCLK\_DAC, thus it is resynchronized in the DAC Controller. Refer to [47.6.2.4 Digital to Analog Conversion](#) for details.
- DAC1 Start Conversion (START1): DATABUF1 value is transferred into DATA1 as soon as DAC1 is ready for the next conversion, and then conversion is started. START1 is considered as asynchronous to GCLK\_DAC, thus it is resynchronized in the DAC Controller. Refer to [47.6.2.4 Digital to Analog Conversion](#) for details.

Writing a '1' to an Event Input bit in the Event Control register (EVCTRL.STARTEIx) enables the corresponding action on input event. Writing a '0' to this bit will disable the corresponding action on input event.

**Note:** When several events are connected to the DAC Controller, the enabled action will be taken on any of the incoming events.

By default, DAC Controller detects rising edge events. Falling edge detection can be enabled by writing '1' to EVCTRL.INVEIx.

Note that if an event occurs before startup time is completed, DATAx is loaded but start of conversion is ignored.

### 47.6.7 Sleep Mode Operation

If the Run In Standby bit in the DAC Control x register DACCTRLx.RUNSTDBY=1, the DACx will continue the conversions in standby sleep mode.

If DACCTRLx.RUNSTDBY=0, the DACx will stop conversions in standby sleep mode.

If DACx conversion is stopped in standby sleep mode, DACx is also disabled to reduce power consumption. When exiting standby sleep mode, DACx is enabled again, therefore a certain startup time is required before starting a new conversion.

DAC Controller is compatible with SleepWalking: if RUNSTDBY=1, when an input event (STARTx) is detected in sleep mode, the DAC Controller will request GCLK\_DAC in order to complete the conversion.

### 47.6.8 Synchronization

Due to asynchronicity between the main clock domain and the peripheral clock domains, some registers need to be synchronized when written or read.

An exception is the Channel Enable bit in the Peripheral Channel Control registers (PCHCTRLm.CHEN). When changing this bit, the bit value must be read-back to ensure the synchronization is complete and to assert glitch free internal operation. Note that changing the bit value under ongoing synchronization will *not* generate an error.

The following bits are synchronized when written:

- Software Reset bit in control register (CTRLA.SWRST)
- Enable bit in control register (CTRLA.ENABLE)

The following registers are synchronized when written:

- DAC0 data register (DATA0)
- DAC1 data register (DATA1)
- DAC0 data buffer register (DATABUF0)
- DAC1 data buffer register (DATABUF1)

Required write synchronization is denoted by the "Write-Synchronized" property in the register description.

#### Related Links

[13.3 Register Synchronization](#)

### 47.6.9 Additional Features

#### 47.6.9.1 DAC0 as Internal Input

The analog output of DAC0, VOUT0, is internally available as input signal for other peripherals (AC, ADC, and OPAMP) when DAC0 is enabled.

**Note:** The pin VOUT0 will be dedicated as internal input and cannot be configured as alternate function.

#### 47.6.9.2 Output Buffer Current Control

Power consumption can be reduced by controlling the output buffer current, according to conversion rate. Writing to the Current Control bits in DAC Control x register (DACCTRLx.[1:0]) will select an output buffer current.

#### Related Links

[47.8.9 DACCTRL0](#)

[47.8.10 DACCTRL1](#)

#### 47.6.9.3 Conversion Refresh

Conversion Refresh only works when the input data is not interpolated, i.e. the Oversampling Rate in the DAC Control register is zero (DACCTRLx.OSR=0x0).

# SAM D5x/E5x Family Data Sheet

## DAC – Digital-to-Analog Converter

The DAC can only maintain its output within one LSB of the desired value for approximately 100µs. When a DAC is used to generate a static voltage or at a rate less than 20kSPS, the conversion must be refreshed periodically. The OSCULP32K clock can start new conversions automatically after a specified period. Write a value to the Refresh bit field in the DAC Control x register (DACCTRLx.REFRESH[3:0]) to select the refresh period according to the formula:

$$T_{\text{REFRESH}} = \text{REFRESH} \times T_{\text{OSCULP32K}}$$

The actual period will depend on the tolerance of the OSCULP32K (see Electrical Characteristics).

If DACCTRLx.REFRESH=0, there is no conversion refresh. DACCTRLx.REFRESH=1 is Reserved.

If no new conversion is started before the refresh period is completed, DACx will convert the DATAx value again.

In standby sleep mode, the refresh mode remains enabled if DACCTRLx.RUNSTDBY=1.

If DATAx is written while a refresh conversion is ongoing, the conversion of the new content of DATAx is postponed until DACx is ready to start the next conversion.

### 47.6.9.4 Differential Mode

DAC0 and DAC1 can be configured to operate in differential mode, i.e. the combined output is a voltage balanced around VREF/2, see also the figure below.

In differential mode, DAC0 and DAC1 are converting synchronously the DATA0 value. DATA0 must therefore be a signed value, represented in two's complement format with DATA0[11] as the signed bit. DATA0 has therefore the range [-2047:2047].

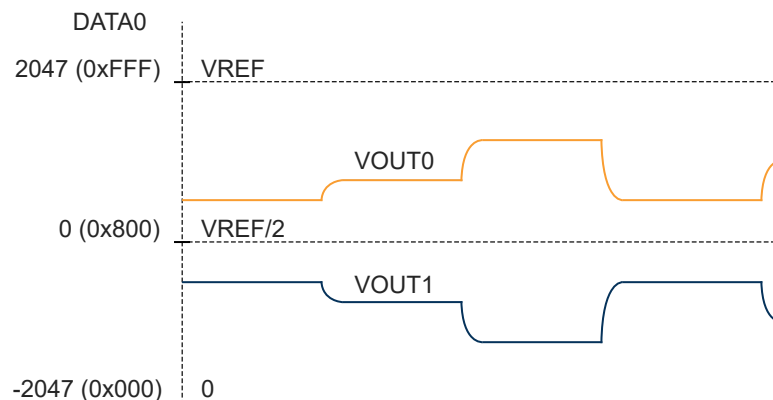
VOUT0 is the positive output and VOUT1 the negative output. The differential output voltage is therefore:

$$V_{\text{OUT}} = \frac{\text{DATA0}}{2047} \times V_{\text{REF}} = (V_{\text{OUT0}} - V_{\text{OUT1}})$$

DACCTRL0 serves as the configuration register for both DAC0 and DAC1. Therefore DACCTRL1 does not need to be written.

The differential mode is enabled by writing a '1' to the Differential bit in the Control B register (CTRLB.DIFF).

**Figure 47-4. DAC Conversions in Differential Mode**





### 47.6.9.5 Dithering Mode

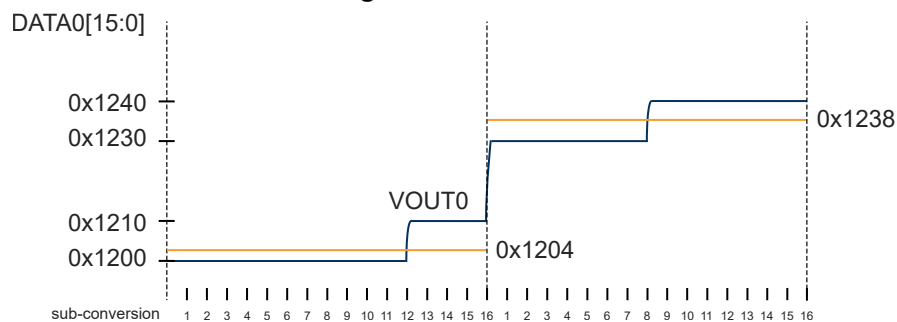
Dithering is enabled by setting DACCTRLx.DITHER to 1. In dithering mode, DATAx is a 16-bit unsigned value where DATAx[15:4] is the 12-bit data converted by DAC and DATAx[3:0] represent the dither bits, used to minimize the quantization error.

The principle is to make 16 sub-conversions of the DATAx[15:4] value or the (DATAx[15:4] + 1) value, so that by averaging those two values, the conversion result of the 16-bit value (DATAx[15:0]) is accurate.

To operate, the STARTx event must be configured to generate 16 events for each DATAx[15:0] conversion, and DATABUFx must be loaded every 16 DAC conversions. EMPTYx event and DMA request are therefore generated every 16 DATABUFx to DATAx transfer. STATUS.EOCx still reports end of each sub-conversions.

Following timing diagram shows examples with DATA0[15:0] = 0x1204 followed by DATA0[15:0] = 0x1238.

**Figure 47-5. DAC Conversions in Dithering Mode**



### 47.6.9.6 Interpolation Mode

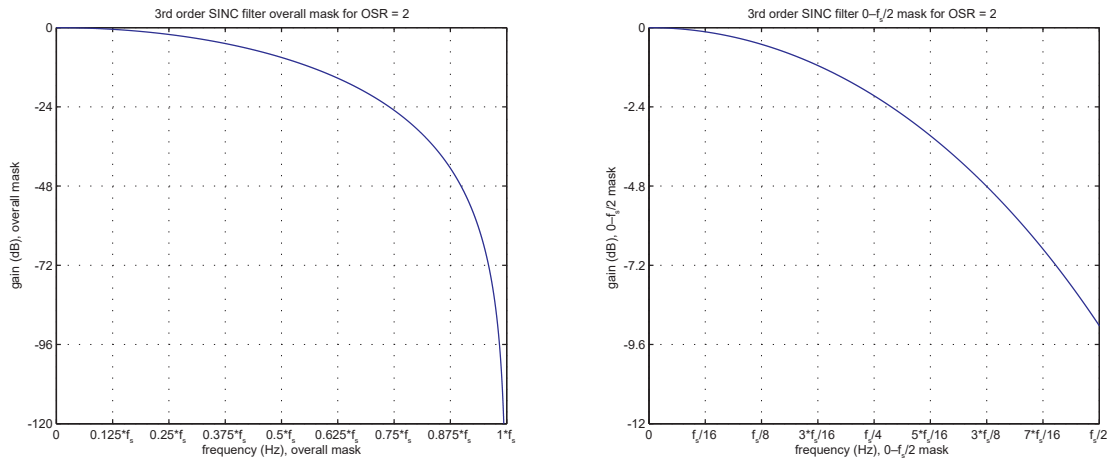
The DAC provides interpolation that allows for oversampling ratios (OSR) of 2x, 4x, 8x, 16x or 32x. Interpolation mode is selected by writing a non-zero value to the Oversampling Ratio bits in the DACx Control register (DACCTRLx.OSR).

The data is sampled once over OSR trigger events and then recomputed at the trigger sample rate using a third-order SINC filter.

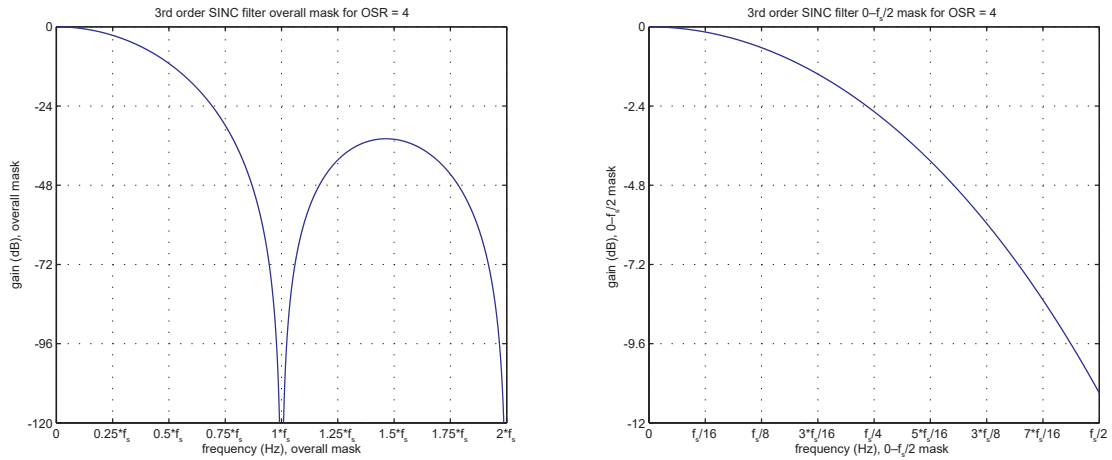
The figures below show the spectral mask of the SINC filter depending on the selected OSR.  $f_s$  is the sampling frequency of the input signal which corresponds to the trigger frequency divided by OSR.

The Filter usage bit DACCTRLx.FEXT determines whether the filter is integrated to the corresponding DAC or used as a standalone filter driven by DMA. If DACCTRLx.FEXT=0, the DAC takes the filter output while the value of RESULTx is reading zero. Conversely, If DACCTRLx.FEXT=1, the DAC value remains zero, and the value of RESULTx register reflects the filter output.

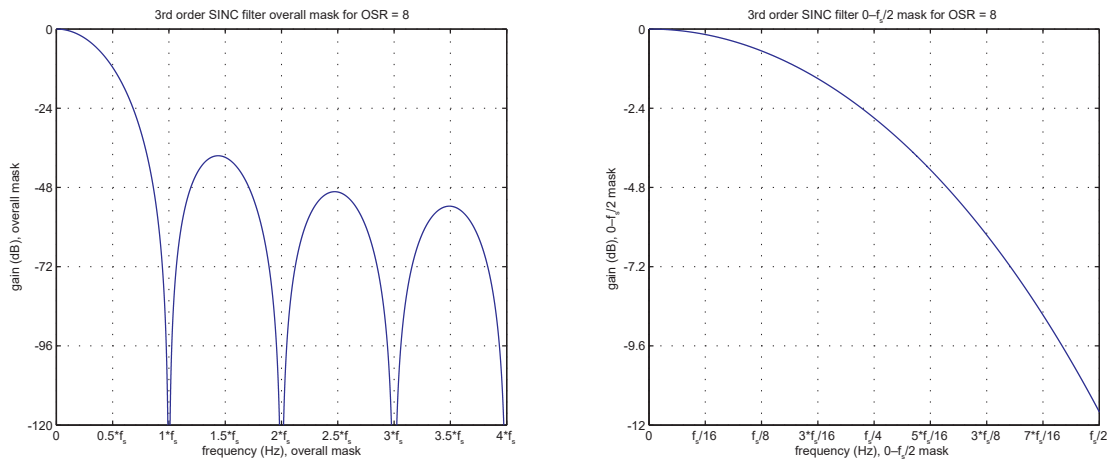
**Figure 47-6. Interpolator Spectral Mask for 2x OSR**



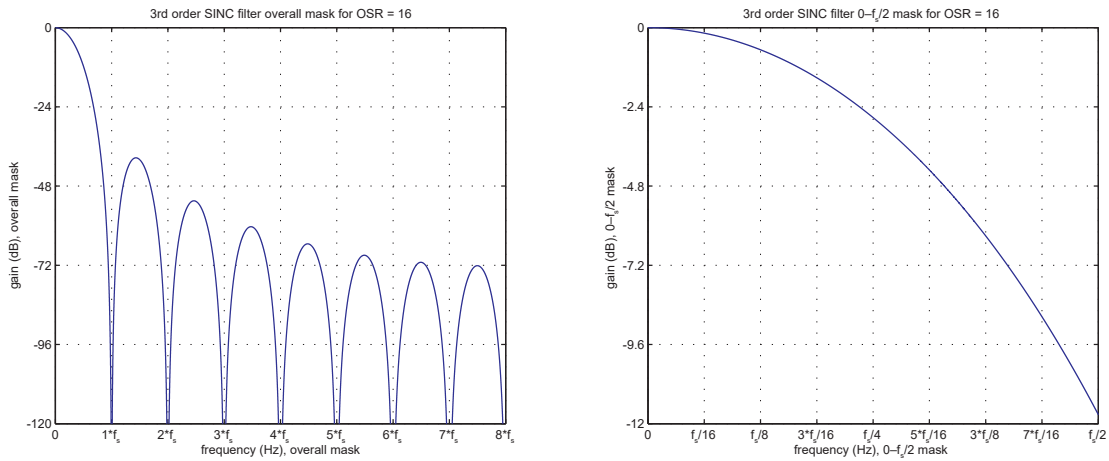
**Figure 47-7. Interpolator Spectral Mask for 4x OSR**



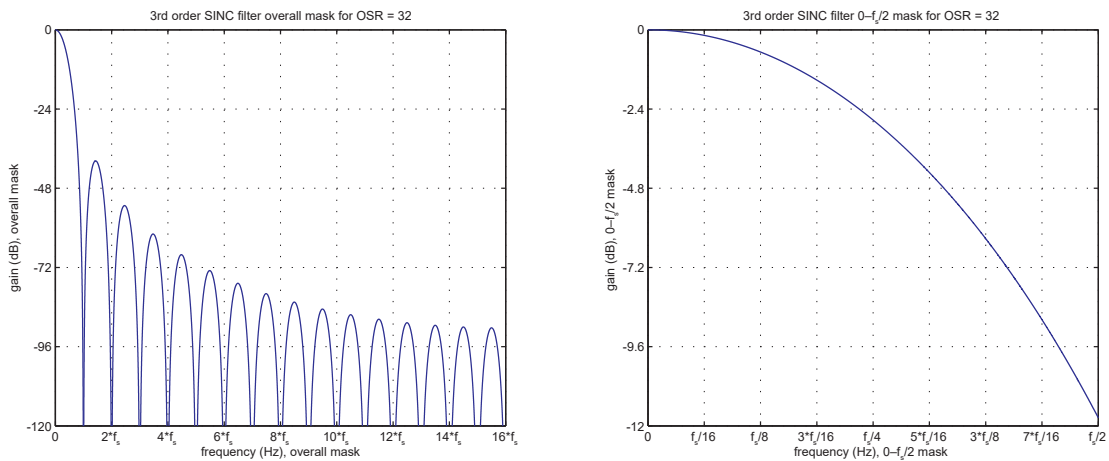
**Figure 47-8. Interpolator Spectral Mask for 8x OSR**



**Figure 47-9. Interpolator Spectral Mask for 16x OSR**



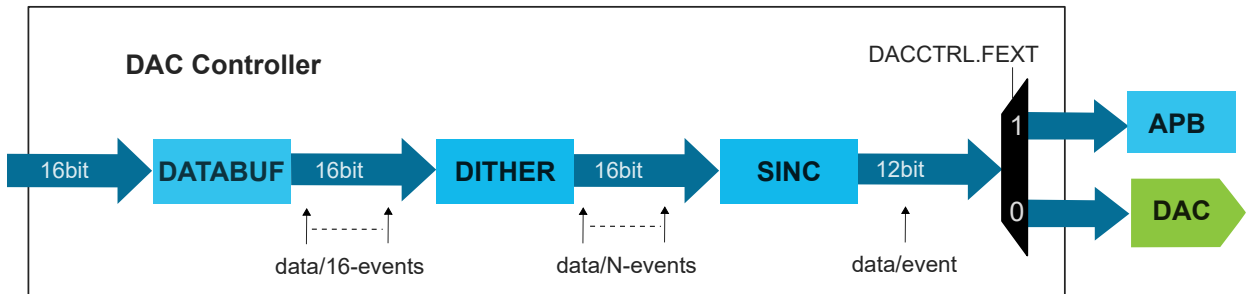
**Figure 47-10. Interpolator Spectral Mask for 32x OSR**



### 47.6.9.7 Dithering-Interpolation Mode

It is possible to enable both Dithering and Interpolation at the same time by setting `DACCTRLx.DITHER` and `DACCTRLx.OSR` prior to enabling the DAC. In Dithering-Interpolation mode, the output of dithering is sampled at a number of events corresponding to the OSR value. The valid OSR value is 2, 4, 8, or 16.

**Figure 47-11. Dithering-Interpolation Data Path**



# SAM D5x/E5x Family Data Sheet

## DAC – Digital-to-Analog Converter

### 47.7 Register Summary

Offset	Name	Bit Pos.								
0x00	<a href="#">CTRLA</a>	7:0							ENABLE	SWRST
0x01	<a href="#">CTRLB</a>	7:0						REFSEL[1:0]		DIFF
0x02	<a href="#">EVCTRL</a>	7:0	RESRDYEO1	RESRDYEO0	INVEI1	INVEI0	EMPTYEO1	EMPTYEO0	STARTEI1	STARTEI0
0x03	Reserved									
0x04	<a href="#">INTENCLR</a>	7:0	OVERRUN1	OVERRUN0	RESRDY1	RESRDY0	EMPTY1	EMPTY0	UNDERRUN1	UNDERRUN0
0x05	<a href="#">INTENSET</a>	7:0	OVERRUN1	OVERRUN0	RESRDY1	RESRDY0	EMPTY1	EMPTY0	UNDERRUN1	UNDERRUN0
0x06	<a href="#">INTFLAG</a>	7:0	OVERRUN1	OVERRUN0	RESRDY1	RESRDY0	EMPTY1	EMPTY0	UNDERRUN1	UNDERRUN0
0x07	<a href="#">STATUS</a>	7:0					EOC1	EOC0	READY1	READY0
0x08	<a href="#">SYNCBUSY</a>	7:0			DATABUF1	DATABUF0	DATA1	DATA0	ENABLE	SWRST
		15:8								
		23:16								
		31:24								
0x0C	<a href="#">DACCTRL0</a>	7:0	DITHER	RUNSTDBY	FEXT			CCTRL[1:0]	ENABLE	LEFTADJ
		15:8	OSR[2:0]					REFRESH[3:0]		
0x0E	<a href="#">DACCTRL1</a>	7:0	DITHER	RUNSTDBY	FEXT			CCTRL[1:0]	ENABLE	LEFTADJ
		15:8	OSR[2:0]					REFRESH[3:0]		
0x10	<a href="#">DATA0</a>	7:0	DATA[7:0]							
		15:8	DATA[15:8]							
0x12	<a href="#">DATA1</a>	7:0	DATA[7:0]							
		15:8	DATA[15:8]							
0x14	<a href="#">DATABUF0</a>	7:0	DATABUF[7:0]							
		15:8	DATABUF[15:8]							
0x16	<a href="#">DATABUF1</a>	7:0	DATABUF[7:0]							
		15:8	DATABUF[15:8]							
0x18	<a href="#">DBGCTRL</a>	7:0								DBGRUN
0x19 ... 0x1B	Reserved									
0x1C	<a href="#">RESULT0</a>	7:0	RESULT[7:0]							
		15:8	RESULT[15:8]							
0x1E	<a href="#">RESULT1</a>	7:0	RESULT[7:0]							
		15:8	RESULT[15:8]							

### 47.8 Register Description

Registers can be 8, 16, or 32 bits wide. Atomic 8-, 16- and 32-bit accesses are supported. In addition, the 8-bit quarters and 16-bit halves of a 32-bit register, and the 8-bit halves of a 16-bit register can be accessed directly.

Some registers are optionally write-protected by the Peripheral Access Controller (PAC). Optional PAC write protection is denoted by the "PAC Write-Protection" property in each individual register description. For details, refer to [47.5.8 Register Access Protection](#).

# SAM D5x/E5x Family Data Sheet

## DAC – Digital-to-Analog Converter

---

Some registers are synchronized when read and/or written. Synchronization is denoted by the "Write-Synchronized" or the "Read-Synchronized" property in each individual register description. For details, refer to [47.6.8 Synchronization](#).

Some registers are enable-protected, meaning they can only be written when the peripheral is disabled. Enable-protection is denoted by the "Enable-Protected" property in each individual register description.

# SAM D5x/E5x Family Data Sheet

## DAC – Digital-to-Analog Converter

### 47.8.1 Control A

**Name:** CTRLA  
**Offset:** 0x00  
**Reset:** 0x00  
**Property:** PAC Write-Protection, Write-Synchronized

	7	6	5	4	3	2	1	0
							ENABLE	SWRST
Access							R/W	R/W
Reset							0	0

**Bit 1 – ENABLE** Enable DAC Controller

Due to synchronization there is delay from writing CTRLA.ENABLE until the peripheral is enabled/disabled. The value written to CTRLA.ENABLE will read back immediately and the corresponding bit in the Synchronization Busy register (SYNCBUSY.ENABLE) will be set. SYNCBUSY.ENABLE will be cleared when the operation is complete.

Value	Description
0	The peripheral is disabled.
1	The peripheral is enabled.

**Bit 0 – SWRST** Software Reset

Writing '0' to this bit has no effect.

Writing '1' to this bit resets all registers in the DAC to their initial state, and the DAC will be disabled.

Writing a '1' to CTRLA.SWRST will always take precedence, meaning that all other writes in the same write-operation will be discarded.

Due to synchronization there is a delay from writing CTRLA.SWRST until the reset is complete.

CTRLA.SWRST and SYNCBUSY.SWRST will both be cleared when the reset is complete.

Value	Description
0	There is no reset operation ongoing.
1	The reset operation is ongoing.

# SAM D5x/E5x Family Data Sheet

## DAC – Digital-to-Analog Converter

### 47.8.2 Control B

**Name:** CTRLB  
**Offset:** 0x01  
**Reset:** 0x02  
**Property:** PAC Write-Protection

	7	6	5	4	3	2	1	0
						REFSEL[1:0]		DIFF
Access						R/W	R/W	R/W
Reset						0	1	0

#### Bits 2:1 – REFSEL[1:0] Reference Selection

This bit field selects the Reference Voltage for both DACs.

Value	Name	Description
0x0	VREFAU	Unbuffered external voltage reference (not buffered in DAC, direct connection)
0x1	VDDANA	Voltage supply
0x2	VREFAB	Buffered external voltage reference (buffered in DAC)
0x3	INTREF	Internal bandgap reference

#### Bit 0 – DIFF Differential Mode Enable

This bit defines the conversion mode for both DACs.

Value	Description
0	Single mode
1	Differential mode

# SAM D5x/E5x Family Data Sheet

## DAC – Digital-to-Analog Converter

### 47.8.3 Event Control

**Name:** EVCTRL  
**Offset:** 0x02  
**Reset:** 0x00  
**Property:** PAC Write-Protection

Bit	7	6	5	4	3	2	1	0
	RESRDYEO1	RESRDYEO0	INVEI1	INVEI0	EMPTYEO1	EMPTYEO0	STARTEI1	STARTEI0
Access	R/W	R/W	R/W	R/W	R/W	R/W	R/W	R/W
Reset	0	0	0	0	0	0	0	0

**Bit 7 – RESRDYEO1** Enable Result Ready of Filter 1 output event

This bit controls whether the RESRDY1 Event is enabled when the interpolated data is ready.

Value	Description
0	Interpolated Data Ready Event is disabled
1	Interpolated Data Ready Event is enabled

**Bit 6 – RESRDYEO0** Enable Result Ready of Filter 0 output event

This bit controls whether the RESRDY0 Event is enabled when the interpolated data is ready.

Value	Description
0	Interpolated Data Ready Event is disabled
1	Interpolated Data Ready Event is enabled

**Bit 5 – INVEI1** Enable Inversion of DAC1 Start Conversion Input Event

This bit defines the detection of the input event for DAC1 START.

Value	Description
0	Input event source is not inverted.
1	Input event source is inverted.

**Bit 4 – INVEI0** Enable Inversion of DAC0 Start Conversion Input Event

This bit defines the detection of the input event for DAC0 START.

Value	Description
0	Input event source is not inverted.
1	Input event source is inverted.

**Bit 3 – EMPTYEO1** Data Buffer Empty Event Output DAC1

This bit indicates if the Data Buffer Empty Event output for DAC1 is enabled.

Value	Description
0	Data Buffer Empty event is disabled.
1	Data Buffer Empty event is enabled.

**Bit 2 – EMPTYEO0** Data Buffer Empty Event Output DAC0

This bit indicates if the Data Buffer Empty Event output for DAC0 is enabled.

Value	Description
0	Data Buffer Empty event is disabled.
1	Data Buffer Empty event is enabled.



# SAM D5x/E5x Family Data Sheet

## DAC – Digital-to-Analog Converter

---

---

**Bit 1 – STARTEI1** Start Conversion Event Input DAC1

This bit indicates if the Start input event for DAC1 is enabled.

Value	Description
0	A new conversion will not be triggered on any incoming event.
1	A new conversion will be triggered on any incoming event.

**Bit 0 – STARTEI0** Start Conversion Event Input DAC0

This bit indicates if the Start input event for DAC0 is enabled.

Value	Description
0	A new conversion will not be triggered on any incoming event.
1	A new conversion will be triggered on any incoming event.

### 47.8.4 Interrupt Enable Clear

**Name:** INTENCLR  
**Offset:** 0x04  
**Reset:** 0x00  
**Property:** PAC Write-Protection

This register allows the user to disable an interrupt without doing a read-modify-write operation. Changes in this register will also be reflected in the Interrupt Enable Set register (INTENSET).

Bit	7	6	5	4	3	2	1	0
	OVERRUN1	OVERRUN0	RESRDY1	RESRDY0	EMPTY1	EMPTY0	UNDERRUN1	UNDERRUN0
Access	R/W	R/W	R/W	R/W	R/W	R/W	R/W	R/W
Reset	0	0	0	0	0	0	0	0

#### Bit 7 – OVERRUN1 Overrun Interrupt Enable for Filter Channel 1

Writing a '0' to this bit has no effect.

Writing a '1' to this bit will clear the Overrun Interrupt Enable for Filter Channel 1 bit, which disables the Filter 1 Overrun interrupt.

Value	Description
0	Filter 1 Result Ready interrupt is disabled.
1	Filter 1 Result Ready interrupt is enabled.

#### Bit 6 – OVERRUN0 Overrun Interrupt Enable for Filter Channel 0

Writing a '0' to this bit has no effect.

Writing a '1' to this bit will clear the Overrun Interrupt Enable for Filter Channel 0 bit, which disables the Filter 0 Overrun interrupt.

Value	Description
0	Filter 0 Result Ready interrupt is disabled.
1	Filter 0 Result Ready interrupt is enabled.

#### Bit 5 – RESRDY1 Filter Channel 1 Result Ready Interrupt Enable

Writing a '0' to this bit has no effect.

Writing a '1' to this bit will clear the Filter Channel 1 Result Ready Interrupt Enable bit, which disables the Filter Channel 1 Result Ready interrupt.

Value	Description
0	Filter 1 Result Ready interrupt is disabled.
1	Filter 1 Result Ready interrupt is enabled.

#### Bit 4 – RESRDY0 Filter Channel 0 Result Ready Interrupt Enable

Writing a '0' to this bit has no effect.

Writing a '1' to this bit will clear the Filter Channel 0 Result Ready Interrupt Enable bit, which disables the Filter Channel 0 Result Ready interrupt.

Value	Description
0	Filter 0 Result Ready interrupt is disabled.
1	Filter 0 Result Ready interrupt is enabled.

#### Bit 3 – EMPTY1 Data Buffer 1 Empty Interrupt Enable

Writing a '0' to this bit has no effect.

# SAM D5x/E5x Family Data Sheet

## DAC – Digital-to-Analog Converter

Writing a '1' to this bit will clear the Data Buffer 1 Empty Interrupt Enable bit, which disables the Data Buffer 1 Empty interrupt.

Value	Description
0	The Data Buffer 1 Empty interrupt is disabled.
1	The Data Buffer 1 Empty interrupt is enabled.

### Bit 2 – EMPTY0 Data Buffer 0 Empty Interrupt Enable

Writing a '0' to this bit has no effect.

Writing a '1' to this bit will clear the Data Buffer 0 Empty Interrupt Enable bit, which disables the Data Buffer 0 Empty interrupt.

Value	Description
0	The Data Buffer 0 Empty interrupt is disabled.
1	The Data Buffer 0 Empty interrupt is enabled.

### Bit 1 – UNDERRUN1 Underrun Interrupt Enable for DAC1

Writing a '0' to this bit has no effect.

Writing a '1' to this bit will clear the Data Buffer 1 Underrun Interrupt Enable bit, which disables the Data Buffer 1 Underrun interrupt.

Value	Description
0	The Data Buffer 1 Underrun interrupt is disabled.
1	The Data Buffer 1 Underrun interrupt is enabled.

### Bit 0 – UNDERRUN0 Underrun Interrupt Enable for DAC0

Writing a '0' to this bit has no effect.

Writing a '1' to this bit will clear the Data Buffer 0 Underrun Interrupt Enable bit, which disables the Data Buffer 0 Underrun interrupt.

Value	Description
0	The Data Buffer 0 Underrun interrupt is disabled.
1	The Data Buffer 0 Underrun interrupt is enabled.

### 47.8.5 Interrupt Enable Set

**Name:** INTENSET  
**Offset:** 0x05  
**Reset:** 0x00  
**Property:** PAC Write-Protection

This register allows the user to disable an interrupt without doing a read-modify-write operation. Changes in this register will also be reflected in the Interrupt Enable Clear register (INTENCLR).

Bit	7	6	5	4	3	2	1	0
	OVERRUN1	OVERRUN0	RESRDY1	RESRDY0	EMPTY1	EMPTY0	UNDERRUN1	UNDERRUN0
Access	R/W	R/W	R/W	R/W	R/W	R/W	R/W	R/W
Reset	0	0	0	0	0	0	0	0

#### Bit 7 – OVERRUN1 Overrun Interrupt Enable for Filter Channel 1

Writing a '0' to this bit has no effect.

Writing a '1' to this bit will set the Overrun Interrupt Enable for Filter Channel 1 bit, which enables the Filter 1 Overrun interrupt.

Value	Description
0	Filter 1 Result Ready interrupt is disabled.
1	Filter 1 Result Ready interrupt is enabled.

#### Bit 6 – OVERRUN0 Overrun Interrupt Enable for Filter Channel 0

Writing a '0' to this bit has no effect.

Writing a '1' to this bit will set the Overrun Interrupt Enable for Filter Channel 0 bit, which enables the Filter 0 Overrun interrupt.

Value	Description
0	Filter 0 Result Ready interrupt is disabled.
1	Filter 0 Result Ready interrupt is enabled.

#### Bit 5 – RESRDY1 Filter Channel 1 Result Ready Interrupt Enable

Writing a '0' to this bit has no effect.

Writing a '1' to this bit will set the Filter Channel 1 Result Ready Interrupt Enable bit, which enables the Filter Channel 1 Result Ready interrupt.

Value	Description
0	Filter 1 Result Ready interrupt is disabled.
1	Filter 1 Result Ready interrupt is enabled.

#### Bit 4 – RESRDY0 Filter Channel 0 Result Ready Interrupt Enable

Writing a '0' to this bit has no effect.

Writing a '1' to this bit will set the Filter Channel 0 Result Ready Interrupt Enable bit, which enables the Filter Channel 0 Result Ready interrupt.

Value	Description
0	Filter 0 Result Ready interrupt is disabled.
1	Filter 0 Result Ready interrupt is enabled.

#### Bit 3 – EMPTY1 Data Buffer 1 Empty Interrupt Enable

Writing a '0' to this bit has no effect.

# SAM D5x/E5x Family Data Sheet

## DAC – Digital-to-Analog Converter

Writing a '1' to this bit will set the Data Buffer 1 Empty Interrupt Enable bit, which enables the Data Buffer 1 Empty interrupt.

Value	Description
0	The Data Buffer 1 Empty interrupt is disabled.
1	The Data Buffer 1 Empty interrupt is enabled.

### Bit 2 – EMPTY0 Data Buffer 0 Empty Interrupt Enable

Writing a '0' to this bit has no effect.

Writing a '1' to this bit will set the Data Buffer 0 Empty Interrupt Enable bit, which enables the Data Buffer 0 Empty interrupt.

Value	Description
0	The Data Buffer 0 Empty interrupt is disabled.
1	The Data Buffer 0 Empty interrupt is enabled.

### Bit 1 – UNDERRUN1 Underrun Interrupt Enable for DAC1

Writing a '0' to this bit has no effect.

Writing a '1' to this bit will set the Data Buffer 1 Underrun Interrupt Enable bit, which enables the Data Buffer 1 Underrun interrupt.

Value	Description
0	The Data Buffer 1 Underrun interrupt is disabled.
1	The Data Buffer 1 Underrun interrupt is enabled.

### Bit 0 – UNDERRUN0 Underrun Interrupt Enable for DAC0

Writing a '0' to this bit has no effect.

Writing a '1' to this bit will set the Data Buffer 0 Underrun Interrupt Enable bit, which enables the Data Buffer 0 Underrun interrupt.

Value	Description
0	The Data Buffer 0 Underrun interrupt is disabled.
1	The Data Buffer 0 Underrun interrupt is enabled.

# SAM D5x/E5x Family Data Sheet

## DAC – Digital-to-Analog Converter

### 47.8.6 Interrupt Flag Status and Clear

**Name:** INTFLAG  
**Offset:** 0x06  
**Reset:** 0x00  
**Property:** -

Bit	7	6	5	4	3	2	1	0
	OVERRUN1	OVERRUN0	RESRDY1	RESRDY0	EMPTY1	EMPTY0	UNDERRUN1	UNDERRUN0
Access	R/W	R/W	R/W	R/W	R/W	R/W	R/W	R/W
Reset	0	0	0	0	0	0	0	0

#### Bit 7 – OVERRUN1 Overrun for Filter Channel 1

This flag is set when the DMA is not cleared while the RESULT1 register gets new data.

Writing a '0' to this bit has no effect.

Writing a '1' to this bit will clear the Overrun for Filter Channel 0 flag.

Value	Description
0	Filter 1 Result Ready interrupt is disabled.
1	Filter 1 Result Ready interrupt is enabled.

#### Bit 6 – OVERRUN0 Overrun for Filter Channel 0

This flag is set when the DMA is not cleared while the RESULT0 register gets new data.

Writing a '0' to this bit has no effect.

Writing a '1' to this bit will clear the Overrun for Filter Channel 0 flag.

#### Bit 5 – RESRDY1 Filter Channel 1 Result Ready

This flag is set when the filter is used as standalone (DACCTRL1.FEXT=1) and the filter output is ready.

Writing a '0' to this bit has no effect.

Writing a '1' to this bit will clear the Filter Channel 1 Result Ready flag.

#### Bit 4 – RESRDY0 Filter Channel 0 Result Ready

This flag is set when the filter is used as standalone (DACCTRL0.FEXT=1) and the filter output is ready.

Writing a '0' to this bit has no effect.

Writing a '1' to this bit will clear the Filter Channel 0 Result Ready flag.

#### Bit 3 – EMPTY1 Data Buffer 1 Empty

This flag is cleared by writing a '1' to it or by writing new data to DATA1 or DATABUF1.

This flag is set when the data buffer for DAC1 is empty and will generate an interrupt request if INTENCLR/INTENSET.EMPTY1=1.

Writing a '0' to this bit has no effect.

Writing a '1' to this bit will clear the Data Buffer 1 Empty interrupt flag.

#### Bit 2 – EMPTY0 Data Buffer 0 Empty

This flag is cleared by writing a '1' to it or by writing new data to DATA0 or DATABUF0.

This flag is set when the data buffer for DAC0 is empty and will generate an interrupt request if INTENCLR/INTENSET.EMPTY0=1.

Writing a '0' to this bit has no effect.

Writing a '1' to this bit will clear the Data Buffer 0 Empty interrupt flag.

**Bit 1 – UNDERRUN1** DAC1 Underrun

This flag is cleared by writing a '1' to it.

This flag is set when a start conversion event (START1) occurred before new data is copied/written to the DAC1 data buffer and will generate an interrupt request if INTENCLR/INTENSET.UNDERRUN1=1.

Writing a '0' to this bit has no effect.

Writing a '1' to this bit will clear the DAC1 Underrun interrupt flag.

**Bit 0 – UNDERRUN0** DAC0 Underrun

This flag is cleared by writing a '1' to it.

This flag is set when a start conversion event (START0) occurred before new data is copied/written to the DAC) data buffer and will generate an interrupt request if INTENCLR/INTENSET.UNDERRUN0=1.

Writing a '0' to this bit has no effect.

Writing a '1' to this bit will clear the DAC0 Underrun interrupt flag.

# SAM D5x/E5x Family Data Sheet

## DAC – Digital-to-Analog Converter

### 47.8.7 Status

**Name:** STATUS  
**Offset:** 0x07  
**Reset:** 0x00  
**Property:** -

	7	6	5	4	3	2	1	0
Access					R	R	R	R
Reset					0	0	0	0

#### Bit 3 – EOC1 DAC1 End of Conversion

This bit is cleared when DATA1 register is written.

Value	Description
0	No conversion completed since last load of DATA1.
1	DAC1 conversion is complete, VOUT1 is stable.

#### Bit 2 – EOC0 DAC0 End of Conversion

This bit is cleared when DATA0 register is written.

Value	Description
0	No conversion completed since last load of DATA0.
1	DAC0 conversion is complete, VOUT0 is stable.

#### Bit 1 – READY1 DAC1 Startup Ready

Value	Description
0	DAC1 is not ready for conversion.
1	Startup time has elapsed, DAC1 is ready for conversion.

#### Bit 0 – READY0 DAC0 Startup Ready

Value	Description
0	DAC0 is not ready for conversion.
1	Startup time has elapsed, DAC0 is ready for conversion.



# SAM D5x/E5x Family Data Sheet

## DAC – Digital-to-Analog Converter

### 47.8.8 Synchronization Busy

**Name:** SYNCBUSY  
**Offset:** 0x08  
**Reset:** 0x00000000  
**Property:** -

	31	30	29	28	27	26	25	24
Access								
Reset								
	23	22	21	20	19	18	17	16
Access								
Reset								
	15	14	13	12	11	10	9	8
Access								
Reset								
	7	6	5	4	3	2	1	0
			DATABUF1	DATABUF0	DATA1	DATA0	ENABLE	SWRST
Access			R	R	R	R	R	R
Reset			0	0	0	0	0	0

#### Bit 5 – DATABUF1 Data Buffer DAC1

This bit is set when DATABUF1 register is written.

This bit is cleared when DATABUF1 synchronization is completed.

Value	Description
0	No ongoing synchronized access.
1	Synchronized access is ongoing.

#### Bit 4 – DATABUF0 Data Buffer DAC0

This bit is set when DATABUF0 register is written.

This bit is cleared when DATABUF0 synchronization is completed.

Value	Description
0	No ongoing synchronized access.
1	Synchronized access is ongoing.

#### Bit 3 – DATA1 Data DAC1

This bit is set when DATA1 register is written.

This bit is cleared when DATA1 synchronization is completed.

Value	Description
0	No ongoing synchronized access.
1	Synchronized access is ongoing.

---

**Bit 2 – DATA0** Data DAC0

This bit is set when DATA0 register is written.

This bit is cleared when DATA0 synchronization is completed.

Value	Description
0	No ongoing synchronized access.
1	Synchronized access is ongoing.

**Bit 1 – ENABLE** DAC Enable Status

This bit is set when CTRLA.ENABLE bit is written.

This bit is cleared when CTRLA.ENABLE synchronization is completed.

Value	Description
0	No ongoing synchronization.
1	Synchronization is ongoing.

**Bit 0 – SWRST** Software Reset

This bit is set when CTRLA.SWRST bit is written.

This bit is cleared when CTRLA.SWRST synchronization is completed.

Value	Description
0	No ongoing synchronization.
1	Synchronization is ongoing.

# SAM D5x/E5x Family Data Sheet

## DAC – Digital-to-Analog Converter

### 47.8.9 DAC0 Control

**Name:** DACCTRL0  
**Offset:** 0x0C  
**Reset:** 0x0000  
**Property:** PAC Write-Protection, Enabled-Protected

	Bit	15	14	13	12	11	10	9	8
		OSR[2:0]				REFRESH[3:0]			
Access		R/W	R/W	R/W		R/W	R/W	R/W	R/W
Reset		0	0	0		0	0	0	0
	Bit	7	6	5	4	3	2	1	0
		DITHER	RUNSTDBY	FEXT		CCTRL[1:0]		ENABLE	LEFTADJ
Access		R/W	R/W	R/W		R/W	R/W	R/W	R/W
Reset		0	0	0		0	0	0	0

#### Bits 15:13 – OSR[2:0] Oversampling Ratio

This field defines the oversampling ratio/interpolation depth.

Value	Name	Description
0x0	OSR_1	1x OSR (no interpolation)
0x1	OSR_2	2x OSR
0x2	OSR_4	4x OSR
0x3	OSR_8	8x OSR
0x4	OSR_16	16x OSR
0x5	OSR_32	32x OSR
other	-	Reserved

#### Bits 11:8 – REFRESH[3:0] Refresh period

This field defines the refresh period. If REFRESH=0x0, the refresh mode is disabled. If REFRESH>0x1, else the refresh period is:

$$T_{\text{REFRESH}} = \text{REFRESH} \times 30\mu\text{s}$$

#### Bit 7 – DITHER Dithering Mode

Value	Description
0	Dithering mode is disabled.
1	Dithering mode is enabled.

#### Bit 6 – RUNSTDBY Run in Standby

This bit controls the behavior of DAC0 during standby sleep mode.

Value	Description
0	DAC0 is disabled during standby sleep mode.
1	DAC0 continues to operate during standby sleep mode.

#### Bit 5 – FEXT External Filter Enable

This bit controls the usage of the filter.

Value	Description
0	The filter is integrated to the DAC

# SAM D5x/E5x Family Data Sheet

## DAC – Digital-to-Analog Converter

Value	Description
1	The filter is used as standalone

### Bits 3:2 – CCTRL[1:0] Current Control

This field defines the current in output buffer according to conversion rate.

#### Current Control

Value	Name	Description
0x0	CC100K	$GCLK\_DAC \leq 1.2\text{MHz}$ (100kSPS)
0x1	CC1M	$1.2\text{MHz} < GCLK\_DAC \leq 6\text{MHz}$ (500kSPS)
0x2	CC12M	$6\text{MHz} < GCLK\_DAC \leq 12\text{MHz}$ (1MSPS)
0x3	Reserved	

### Bit 1 – ENABLE Enable DAC0

This bit enables DAC0 when DAC Controller is enabled (CTRLA.ENABLE).

Value	Description
0	DAC0 is disabled.
1	DAC0 is enabled.

### Bit 0 – LEFTADJ Left Adjusted Data

This bit controls how the 12-bit conversion data is adjusted in the Data and Data Buffer registers.

Value	Description
0	DATA0 and DATABUF0 registers are right-adjusted.
1	DATA0 and DATABUF0 registers are left-adjusted.

# SAM D5x/E5x Family Data Sheet

## DAC – Digital-to-Analog Converter

### 47.8.10 DAC1 Control

**Name:** DACCTRL1  
**Offset:** 0x0E  
**Reset:** 0x0000  
**Property:** PAC Write-Protection, Enabled-Protected

	Bit	15	14	13	12	11	10	9	8
		OSR[2:0]				REFRESH[3:0]			
Access		R/W	R/W	R/W		R/W	R/W	R/W	R/W
Reset		0	0	0		0	0	0	0
	Bit	7	6	5	4	3	2	1	0
		DITHER	RUNSTDBY	FEXT		CCTRL[1:0]		ENABLE	LEFTADJ
Access		R/W	R/W	R/W		R/W	R/W	R/W	R/W
Reset		0	0	0		0	0	0	0

#### Bits 15:13 – OSR[2:0] Oversampling Ratio

This field defines the oversampling ratio/interpolation depth.

Value	Name	Description
0x0	OSR_1	1x OSR (no interpolation)
0x1	OSR_2	2x OSR
0x2	OSR_4	4x OSR
0x3	OSR_8	8x OSR
0x4	OSR_16	16x OSR
0x5	OSR_32	32x OSR
other	-	Reserved

#### Bits 11:8 – REFRESH[3:0] Refresh period

This field defines the refresh period. If REFRESH=0x0, the refresh mode is disabled. If REFRESH>0x1, else the refresh period is:

$$T_{\text{REFRESH}} = \text{REFRESH} \times 30\mu\text{s}$$

#### Bit 7 – DITHER Dithering Mode

Value	Description
0	Dithering mode is disabled.
1	Dithering mode is enabled.

#### Bit 6 – RUNSTDBY Run in Standby

This bit controls the behavior of DAC1 during standby sleep mode.

Value	Description
0	DAC1 is disabled during standby sleep mode.
1	DAC1 continues to operate during standby sleep mode.

#### Bit 5 – FEXT External Filter Enable

This bit controls the usage of the filter.

Value	Description
0	The filter is integrated to the DAC

# SAM D5x/E5x Family Data Sheet

## DAC – Digital-to-Analog Converter

Value	Description
1	The filter is used as standalone

### Bits 3:2 – CTRL[1:0] Current Control

This field defines the current in output buffer.

#### Current Control

Value	Name	Description
0x0	CC100K	GCLK_DAC <= 1.2MHz (100kSPS)
0x1	CC1M	1.2MHz < GCLK_DAC <= 6MHz (500kSPS)
0x2	CC12M	6MHz < GCLK_DAC <= 12MHz (1MSPS)
0x3		Reserved

### Bit 1 – ENABLE Enable DAC1

This bit enables DAC1 when DAC Controller is enabled (CTRLA.ENABLE).

Value	Description
0	DAC1 is disabled.
1	DAC1 is enabled.

### Bit 0 – LEFTADJ Left Adjusted Data

This bit controls how the 12-bit conversion data is adjusted in the Data and Data Buffer registers.

Value	Description
0	DATA1 and DATABUF1 registers are right-adjusted.
1	DATA1 and DATABUF1 registers are left-adjusted.

# SAM D5x/E5x Family Data Sheet

## DAC – Digital-to-Analog Converter

### 47.8.11 Data DAC0

**Name:** DATA0  
**Offset:** 0x10  
**Reset:** 0x0000  
**Property:** PAC Write-Protection, Write-Synchronized

	Bit	15	14	13	12	11	10	9	8
		DATA[15:8]							
Access		W	W	W	W	W	W	W	W
Reset		0	0	0	0	0	0	0	0
	Bit	7	6	5	4	3	2	1	0
		DATA[7:0]							
Access		W	W	W	W	W	W	W	W
Reset		0	0	0	0	0	0	0	0

**Bits 15:0 – DATA[15:0] DAC0 Data**

DATA0 register contains the 12-bit value that is converted to a voltage by the DAC0. The adjustment of these 12 bits within the 16-bit register is controlled by DACCTRL0.LEFTADJ:

- DATA[11:0] when DACCTRL0.LEFTADJ=0.
- DATA[15:4] when DACCTRL0.LEFTADJ=1.

In dithering mode (whatever DACCTRL0.LEFTADJ value):

- DATA[15:4] are the 12-bit converted by DAC0.
- DATA[3:0] are the dither bits.

# SAM D5x/E5x Family Data Sheet

## DAC – Digital-to-Analog Converter

### 47.8.12 Data DAC1

**Name:** DATA1  
**Offset:** 0x12  
**Reset:** 0x0000  
**Property:** PAC Write-Protection, Write-Synchronized

	Bit	15	14	13	12	11	10	9	8
		DATA[15:8]							
Access		W	W	W	W	W	W	W	W
Reset		0	0	0	0	0	0	0	0
	Bit	7	6	5	4	3	2	1	0
		DATA[7:0]							
Access		W	W	W	W	W	W	W	W
Reset		0	0	0	0	0	0	0	0

**Bits 15:0 – DATA[15:0] DAC1 Data**

DATA1 register contains the 12-bit value that is converted to a voltage by the DAC1. The adjustment of these 12 bits within the 16-bit register is controlled by DACCTRL1.LEFTADJ:

- DATA[11:0] when DACCTRL1.LEFTADJ=0.
- DATA[15:4] when DACCTRL1.LEFTADJ=1.

In dithering mode (whatever DACCTRL1.LEFTADJ value):

- DATA[15:4] are the 12-bit converted by DAC1.
- DATA[3:0] are the dither bits.



# SAM D5x/E5x Family Data Sheet

## DAC – Digital-to-Analog Converter

### 47.8.13 Data Buffer DAC0

**Name:** DATABUF0  
**Offset:** 0x14  
**Reset:** 0x0000  
**Property:** Write-Synchronized

	Bit	15	14	13	12	11	10	9	8
		DATABUF[15:8]							
Access		W	W	W	W	W	W	W	W
Reset		0	0	0	0	0	0	0	0
	Bit	7	6	5	4	3	2	1	0
		DATABUF[7:0]							
Access		W	W	W	W	W	W	W	W
Reset		0	0	0	0	0	0	0	0

**Bits 15:0 – DATABUF[15:0] DAC0 Data Buffer**

DATABUF0 contains the value to be transferred into DATA0 when a START0 event occurs.

# SAM D5x/E5x Family Data Sheet

## DAC – Digital-to-Analog Converter

### 47.8.14 Data Buffer DAC1

**Name:** DATABUF1  
**Offset:** 0x16  
**Reset:** 0x0000  
**Property:** Write-Synchronized

	Bit	15	14	13	12	11	10	9	8
		DATABUF[15:8]							
Access		W	W	W	W	W	W	W	W
Reset		0	0	0	0	0	0	0	0
	Bit	7	6	5	4	3	2	1	0
		DATABUF[7:0]							
Access		W	W	W	W	W	W	W	W
Reset		0	0	0	0	0	0	0	0

**Bits 15:0 – DATABUF[15:0] DAC1 Data Buffer**

DATABUF1 contains the value to be transferred into DATA1 when a START1 event occurs.

# SAM D5x/E5x Family Data Sheet

## DAC – Digital-to-Analog Converter

### 47.8.15 Debug Control

**Name:** DBGCTRL  
**Offset:** 0x18  
**Reset:** 0x00  
**Property:** PAC Write-Protection

Bit	7	6	5	4	3	2	1	0
								DBGRUN
Access								
Reset								0

#### Bit 0 – DBGRUN Debug Run

This bit is not reset by a software reset.

This bit controls the functionality when the CPU is halted by an external debugger.

Value	Description
0	The DAC is halted when the CPU is halted by an external debugger. Any ongoing conversion will complete.
1	The DAC continues normal operation when the CPU is halted by an external debugger.

# SAM D5x/E5x Family Data Sheet

## DAC – Digital-to-Analog Converter

### 47.8.16 Result 0

**Name:** RESULT0  
**Offset:** 0x1C  
**Reset:** 0x0000  
**Property:** Read-Synchronized

	Bit	15	14	13	12	11	10	9	8
		RESULT[15:8]							
Access		R	R	R	R	R	R	R	R
Reset		0	0	0	0	0	0	0	0
	Bit	7	6	5	4	3	2	1	0
		RESULT[7:0]							
Access		R	R	R	R	R	R	R	R
Reset		0	0	0	0	0	0	0	0

**Bits 15:0 – RESULT[15:0]** Channel 0 Filter Output

RESULT[15:0] contains the value of the interpolated data written to DATA0 or DATABUF0 in standalone mode (DACCTRL0.FEXT=1).

# SAM D5x/E5x Family Data Sheet

## DAC – Digital-to-Analog Converter

### 47.8.17 Result 1

**Name:** RESULT1  
**Offset:** 0x1E  
**Reset:** 0x0000  
**Property:** Read-Synchronized

	Bit	15	14	13	12	11	10	9	8
		RESULT[15:8]							
Access		R	R	R	R	R	R	R	R
Reset		0	0	0	0	0	0	0	0
	Bit	7	6	5	4	3	2	1	0
		RESULT[7:0]							
Access		R	R	R	R	R	R	R	R
Reset		0	0	0	0	0	0	0	0

**Bits 15:0 – RESULT[15:0]** Channel 0 Filter Output

RESULT[15:0] contains the value of the interpolated data written to DATA1 or DATABUF1 in standalone mode (DACCTRL1.FEXT=1).

## 48. TC – Timer/Counter

### 48.1 Overview

There are up to eight TC peripheral instances.

Each TC consists of a counter, a prescaler, compare/capture channels and control logic. The counter can be set to count events, or clock pulses. The counter, together with the compare/capture channels, can be configured to timestamp input events or IO pin edges, allowing for capturing of frequency and/or pulse width.

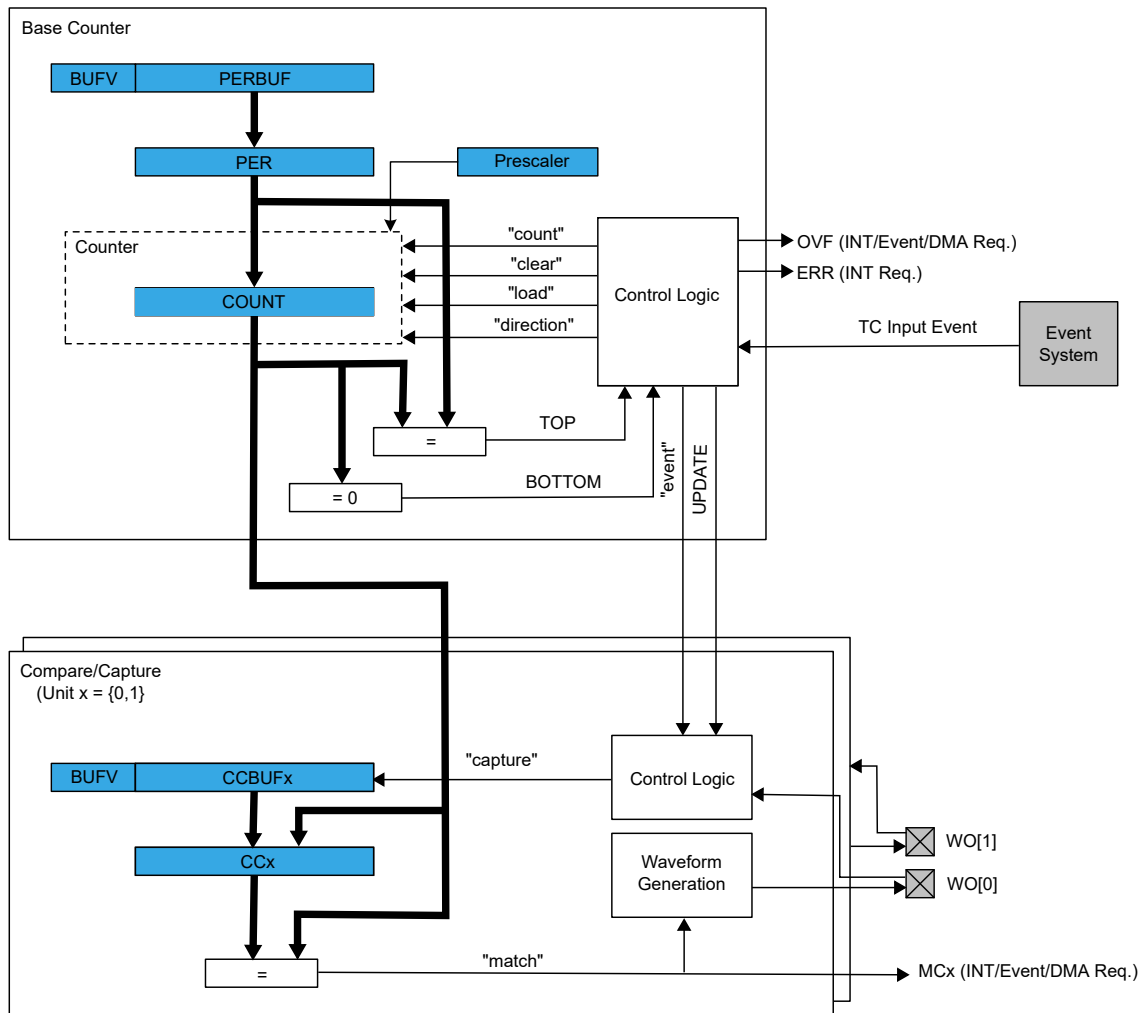
A TC can also perform waveform generation, such as frequency generation and pulse-width modulation.

### 48.2 Features

- Selectable configuration
  - 8-, 16- or 32-bit TC operation, with compare/capture channels
- 2 compare/capture channels (CC) with:
  - Double buffered timer period setting (in 8-bit mode only)
  - Double buffered compare channel
- Waveform generation
  - Frequency generation
  - Single-slope pulse-width modulation
- Input capture
  - Event / IO pin edge capture
  - Frequency capture
  - Pulse-width capture
  - Time-stamp capture
  - Minimum and maximum capture
- One input event
- Interrupts/output events on:
  - Counter overflow/underflow
  - Compare match or capture
- Internal prescaler
- DMA support

### 48.3 Block Diagram

Figure 48-1. Timer/Counter Block Diagram



### 48.4 Signal Description

Table 48-1. Signal Description for TC.

Signal Name	Type	Description
WO[1:0]	Digital output	Waveform output
	Digital input	Capture input

Refer to *I/O Multiplexing and Considerations* for details on the pin mapping for this peripheral. One signal can be mapped on several pins.

### Related Links

[6. I/O Multiplexing and Considerations](#)

## 48.5 Product Dependencies

In order to use this peripheral, other parts of the system must be configured correctly, as described below.

### 48.5.1 I/O Lines

In order to use the I/O lines of this peripheral, the I/O pins must be configured using the I/O Pin Controller (PORT).

**Table 48-2. I/O Lines**

Instance	Signal	I/O Line	Peripheral Function
MODULE0	SIGNAL	PAxx	A

### Related Links

[32. PORT - I/O Pin Controller](#)

### 48.5.2 Power Management

This peripheral can continue to operate in any Sleep mode where its source clock is running. The interrupts can wake up the device from Sleep modes. Events connected to the event system can trigger other operations in the system without exiting Sleep modes.

### Related Links

[18. PM – Power Manager](#)

### 48.5.3 Clocks

The TC bus clocks (CLK\_TCx\_APB) can be enabled and disabled in the Main Clock Module. The default state of CLK\_TCx\_APB can be found in the *Peripheral Clock Masking*.

The generic clocks (GCLK\_TCx) are asynchronous to the user interface clock (CLK\_TCx\_APB). Due to this asynchronicity, accessing certain registers will require synchronization between the clock domains. Refer to [Synchronization](#) for further details.

**Note:** Two instances of the TC may share a peripheral clock channel. In this case, they cannot be set to different clock frequencies. Refer to the peripheral clock channel mapping of the Generic Clock Controller (GCLK.PCHCTRLm) to identify shared peripheral clocks.

### Related Links

[14.8.4 PCHCTRLm](#)

[15.6.2.6 Peripheral Clock Masking](#)

### 48.5.4 DMA

The DMA request lines are connected to the DMA Controller (DMAC). In order to use DMA requests with this peripheral the DMAC must be configured first. Refer to *DMAC – Direct Memory Access Controller* for details.

### Related Links

[22. DMAC – Direct Memory Access Controller](#)



### 48.5.5 Interrupts

The interrupt request line is connected to the Interrupt Controller. In order to use interrupt requests of this peripheral, the Interrupt Controller (NVIC) must be configured first. Refer to *Nested Vector Interrupt Controller* for details.

#### Related Links

[10.2 Nested Vector Interrupt Controller](#)

### 48.5.6 Events

The events of this peripheral are connected to the Event System.

#### Related Links

[31. EVSYS – Event System](#)

### 48.5.7 Debug Operation

When the CPU is halted in Debug mode, this peripheral will halt normal operation. This peripheral can be forced to continue operation during debugging - refer to the Debug Control (DBGCTRL) register for details.

#### Related Links

[48.7.1.11 DBGCTRL](#)

### 48.5.8 Register Access Protection

Registers with write access can be optionally write-protected by the Peripheral Access Controller (PAC), except for the following:

- Interrupt Flag Status and Clear register (INTFLAG)
- Status register (STATUS)
- Count register (COUNT)
- Period and Period Buffer registers (PER, PERBUF)
- Compare/Capture Value registers and Compare/Capture Value Buffer registers (CCx, CCBUFx)

**Note:** Optional write protection is indicated by the "PAC Write Protection" property in the register description.

Write protection does not apply for accesses through an external debugger.

### 48.5.9 Analog Connections

Not applicable.

## 48.6 Functional Description

### 48.6.1 Principle of Operation

The following definitions are used throughout the documentation:

# SAM D5x/E5x Family Data Sheet

## TC – Timer/Counter

**Table 48-3. Timer/Counter Definitions**

Name	Description
TOP	The counter reaches TOP when it becomes equal to the highest value in the count sequence. The TOP value can be the same as Period (PER) or the Compare Channel 0 (CC0) register value depending on the waveform generator mode in <a href="#">48.6.2.6.1 Waveform Output Operations</a> .
ZERO	The counter is ZERO when it contains all zeroes
MAX	The counter reaches MAX when it contains all ones
UPDATE	The timer/counter signals an update when it reaches ZERO or TOP, depending on the direction settings.
Timer	The timer/counter clock control is handled by an internal source
Counter	The clock control is handled externally (e.g. counting external events)
CC	For compare operations, the CC are referred to as “compare channels” For capture operations, the CC are referred to as “capture channels.”

Each TC instance has up to two compare/capture channels (CC0 and CC1).

The counter in the TC can either count events from the Event System, or clock ticks of the GCLK\_TCx clock, which may be divided by the prescaler.

The counter value is passed to the CCx where it can be either compared to user-defined values or captured.

For optimized timing the CCx and CCBUFx registers share a common resource. When writing into CCBUFx, lock the access to the corresponding CCx register (SYNCBUSY.CCX = 1) till the CCBUFx register value is not loaded into the CCx register (BUFVx == 1). Each buffer register has a buffer valid (BUFV) flag that indicates when the buffer contains a new value.

The Counter register (COUNT) and the Compare and Capture registers with buffers (CCx and CCBUFx) can be configured as 8-, 16- or 32-bit registers, with according MAX values. Mode settings (CTRLA.MODE) determine the maximum range of the Counter register.

In 8-bit mode, a Period Value (PER) register and its Period Buffer Value (PERBUF) register are also available. The counter range and the operating frequency determine the maximum time resolution achievable with the TC peripheral.

The TC can be set to count up or down. Under normal operation, the counter value is continuously compared to the TOP or ZERO value to determine whether the counter has reached that value. On a comparison match the TC can request DMA transactions, or generate interrupts or events for the Event System.

In compare operation, the counter value is continuously compared to the values in the CCx registers. In case of a match the TC can request DMA transactions, or generate interrupts or events for the Event System. In waveform generator mode, these comparisons are used to set the waveform period or pulse width.

Capture operation can be enabled to perform input signal period and pulse width measurements, or to capture selectable edges from an IO pin or internal event from Event System.

### 48.6.2 Basic Operation

#### 48.6.2.1 Initialization

The following registers are enable-protected, meaning that they can only be written when the TC is disabled (CTRLA.ENABLE =0):

- Control A register (CTRLA), except the Enable (ENABLE) and Software Reset (SWRST) bits
- Drive Control register (DRVCTRL)
- Wave register (WAVE)
- Event Control register (EVCTRL)

Writing to Enable-Protected bits and setting the CTRLA.ENABLE bit can be performed in a single 32-bit access of the CTRLA register. Writing to Enable-Protected bits and clearing the CTRLA.ENABLE bit cannot be performed in a single 32-bit access.

Before enabling the TC, the peripheral must be configured by the following steps:

1. Enable the TC bus clock (CLK\_TCx\_APB).
2. Select 8-, 16- or 32-bit counter mode via the TC Mode bit group in the Control A register (CTRLA.MODE). The default mode is 16-bit.
3. Select one wave generation operation in the Waveform Generation Operation bit group in the WAVE register (WAVE.WAVEGEN).
4. If desired, the GCLK\_TCx clock can be prescaled via the Prescaler bit group in the Control A register (CTRLA.PRESCALER).
  - If the prescaler is used, select a prescaler synchronization operation via the Prescaler and Counter Synchronization bit group in the Control A register (CTRLA.PRESYNC).
5. If desired, select one-shot operation by writing a '1' to the One-Shot bit in the Control B Set register (CTRLBSET.ONESHOT).
6. If desired, configure the counting direction 'down' (starting from the TOP value) by writing a '1' to the Counter Direction bit in the Control B register (CTRLBSET.DIR).
7. For capture operation, enable the individual channels to capture in the Capture Channel x Enable bit group in the Control A register (CTRLA.CAPTEN).
8. If desired, enable inversion of the waveform output or IO pin input signal for individual channels via the Invert Enable bit group in the Drive Control register (DRVCTRL.INVEN).

#### 48.6.2.2 Enabling, Disabling, and Resetting

The TC is enabled by writing a '1' to the Enable bit in the Control A register (CTRLA.ENABLE). The TC is disabled by writing a zero to CTRLA.ENABLE.

The TC is reset by writing a '1' to the Software Reset bit in the Control A register (CTRLA.SWRST). All registers in the TC, except DBGCTRL, will be reset to their initial state. Refer to the [CTRLA](#) register for details.

The TC should be disabled before the TC is reset in order to avoid undefined behavior.

#### 48.6.2.3 Prescaler Selection

The GCLK\_TCx is fed into the internal prescaler.

The prescaler consists of a counter that counts up to the selected prescaler value, whereupon the output of the prescaler toggles.

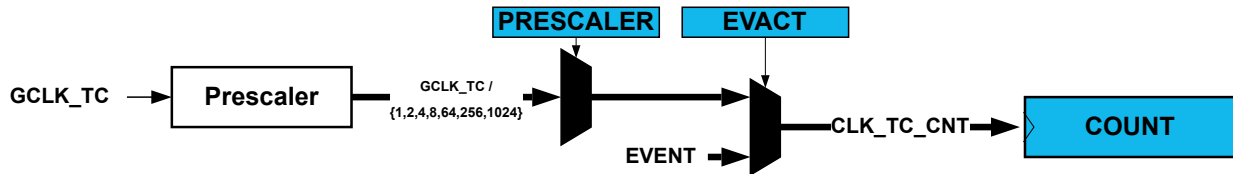
If the prescaler value is higher than one, the Counter Update condition can be optionally executed on the next GCLK\_TCx clock pulse or the next prescaled clock pulse. For further details, refer to Prescaler (CTRLA.PRESCALER) and Counter Synchronization (CTRLA.PRESYNC) description.

Prescaler outputs from 1 to 1/1024 are available. For a complete list of available prescaler outputs, see the register description for the Prescaler bit group in the Control A register (CTRLA.PRESCALER).

**Note:** When counting events, the prescaler is bypassed.

The joint stream of prescaler ticks and event action ticks is called CLK\_TC\_CNT.

**Figure 48-2. Prescaler**



### 48.6.2.4 Counter Mode

The counter mode is selected by the Mode bit group in the Control A register (CTRLA.MODE). By default, the counter is enabled in the 16-bit counter resolution. Three counter resolutions are available:

- COUNT8: The 8-bit TC has its own Period Value and Period Buffer Value registers (PER and PERBUF).
- COUNT16: 16-bit is the default counter mode. There is no dedicated period register in this mode.
- COUNT32: 32-bit mode is achieved by pairing two 16-bit TC peripherals. TC(2n) is paired with TC(2n + 1).

When paired, the TC peripherals are configured using the registers of the even-numbered TC. The TC bus clocks (CLK\_TCx\_APB) for both master and slave TCs need to be enabled.

The odd-numbered partner will act as a slave, and the Slave bit in the Status register (STATUS.SLAVE) will be set. The register values of a slave will not reflect the registers of the 32-bit counter. Writing to any of the slave registers will not affect the 32-bit counter. Normal access to the slave COUNT and CCx registers is not allowed.

### 48.6.2.5 Counter Operations

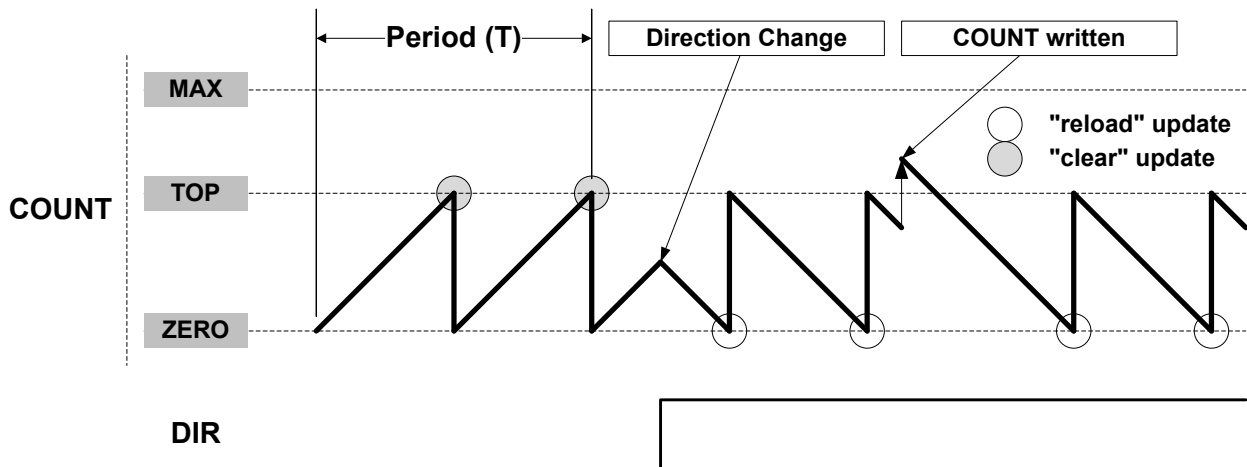
Depending on the mode of operation, the counter is cleared, reloaded, incremented, or decremented at each TC clock input (CLK\_TC\_CNT). A counter clear or reload marks the end of the current counter cycle and the start of a new one.

The counting direction is set by the Direction bit in the Control B register (CTRLB.DIR). If this bit is zero the counter is counting up, and counting down if CTRLB.DIR=1. The counter will count up or down for each tick (clock or event) until it reaches TOP or ZERO. When it is counting up and TOP is reached, the counter will be set to zero at the next tick (overflow) and the Overflow Interrupt Flag in the Interrupt Flag Status and Clear register (INTFLAG.OVF) will be set. When it is counting down, the counter is reloaded with the TOP value when ZERO is reached (underflow), and INTFLAG.OVF is set.

INTFLAG.OVF can be used to trigger an interrupt, a DMA request, or an event. An overflow/underflow occurrence (i.e., a compare match with TOP/ZERO) will stop counting if the One-Shot bit in the Control B register is set (CTRLBSET.ONESHOT).

It is possible to change the counter value (by writing directly in the COUNT register) even when the counter is running. When starting the TC, the COUNT value will be either ZERO or TOP (depending on the counting direction set by CTRLBSET.DIR or CTRLBCLR.DIR), unless a different value has been written to it, or the TC has been stopped at a value other than ZERO. The write access has higher priority than count, clear, or reload. The direction of the counter can also be changed when the counter is running. See also the following figure.

**Figure 48-3. Counter Operation**



Due to asynchronous clock domains, the internal counter settings are written when the synchronization is complete. Normal operation must be used when using the counter as timer base for the capture channels.

#### 48.6.2.5.1 Stop Command and Event Action

A Stop command can be issued from software by using Command bits in the Control B Set register (CTRLBSET.CMD = 0x2, STOP). When a Stop is detected while the counter is running, the counter will not retain its current value. All waveforms are cleared and the Stop bit in the Status register is set (STATUS.STOP).

#### 48.6.2.5.2 Re-Trigger Command and Event Action

A re-trigger command can be issued from software by writing the Command bits in the Control B Set register (CTRLBSET.CMD = 0x1, RETRIGGER), or from event when a re-trigger event action is configured in the Event Control register (EVCTRL.EVACT = 0x1, RETRIGGER).

When the command is detected during counting operation, the counter will be reloaded or cleared, depending on the counting direction (CTRLBSET.DIR or CTRLBCLR.DIR). When the re-trigger command is detected while the counter is stopped, the counter will resume counting from the current value in the COUNT register.

**Note:** When a re-trigger event action is configured in the Event Action bits in the Event Control register (EVCTRL.EVACT=0x1, RETRIGGER), enabling the counter will not start the counter. The counter will start on the next incoming event and restart on corresponding following event.

#### 48.6.2.5.3 Count Event Action

The TC can count events. When an event is received, the counter increases or decreases the value, depending on direction settings (CTRLBSET.DIR or CTRLBCLR.DIR). The count event action can be selected by the Event Action bit group in the Event Control register (EVCTRL.EVACT=0x2, COUNT).

**Note:** If this operation mode is selected, PWM generation is not supported.

#### 48.6.2.5.4 Start Event Action

The TC can start counting operation on an event when previously stopped. In this configuration, the event has no effect if the counter is already counting. When the peripheral is enabled, the counter operation starts when the event is received or when a re-trigger software command is applied.

The Start TC on Event action can be selected by the Event Action bit group in the Event Control register (EVCTRL.EVACT=0x3, START).

### 48.6.2.6 Compare Operations

By default, the Compare/Capture channel is configured for compare operations.

When using the TC and the Compare/Capture Value registers (CCx) for compare operations, the counter value is continuously compared to the values in the CCx registers. This can be used for timer or for waveform operation.

The Channel x Compare Buffer (CCBUFx) registers provide double buffer capability. The double buffering synchronizes the update of the CCx register with the buffer value at the UPDATE condition or a forced update command (CTRLBSET.CMD=UPDATE). For further details, refer to [48.6.2.7 Double Buffering](#). The synchronization prevents the occurrence of odd-length, non-symmetrical pulses and ensures glitch-free output.

#### 48.6.2.6.1 Waveform Output Operations

The compare channels can be used for waveform generation on output port pins. To make the waveform available on the connected pin, the following requirements must be fulfilled:

1. Choose a Waveform Generation mode in the Waveform Generation Operation bit in Waveform register (WAVE.WAVEGEN).
2. Optionally invert the waveform output WO[x] by writing the corresponding Output Waveform x Invert Enable bit in the Driver Control register (DRVCTRL.INVENx).
3. Configure the pins with the I/O Pin Controller. Refer to *PORT - I/O Pin Controller* for details.  
**Note:** Event must not be used when the compare channel is set in waveform output operating mode.

The counter value is continuously compared with each CCx value. On a comparison match, the Match or Capture Channel x bit in the Interrupt Flag Status and Clear register (INTFLAG.MCx) will be set on the next zero-to-one transition of CLK\_TC\_CNT (see Normal Frequency Operation). An interrupt/and or event can be generated on comparison match if enabled. The same condition generates a DMA request.

There are four waveform configurations for the Waveform Generation Operation bit group in the Waveform register (WAVE.WAVEGEN). This will influence how the waveform is generated and impose restrictions on the top value. The configurations are:

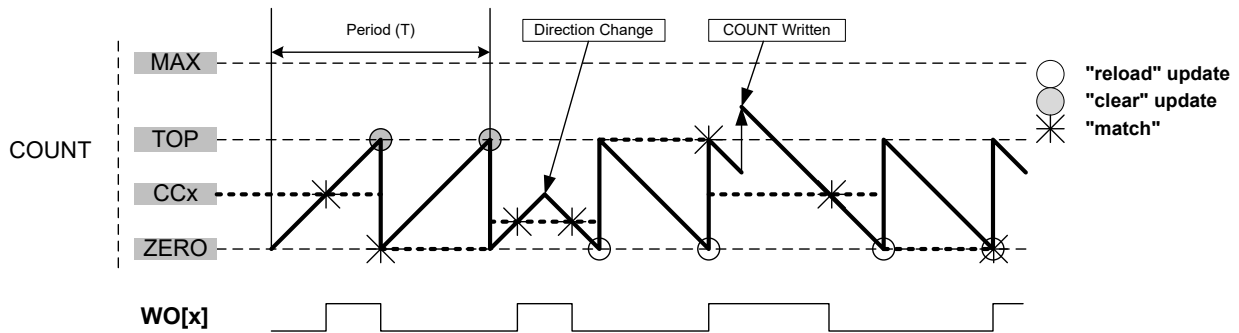
- Normal frequency (NFRQ)
- Match frequency (MFRQ)
- Normal pulse-width modulation (NPWM)
- Match pulse-width modulation (MPWM)

When using NPWM or NFRQ configuration, the TOP will be determined by the counter resolution. In 8-bit Counter mode, the Period register (PER) is used as TOP, and the TOP can be changed by writing to the PER register. In 16- and 32-bit Counter mode, TOP is fixed to the maximum (MAX) value of the counter.

#### Normal Frequency Generation (NFRQ)

For Normal Frequency Generation, the period time (T) is controlled by the period register (PER) for 8-bit Counter mode and MAX for 16- and 32-bit mode. The waveform generation output (WO[x]) is toggled on each compare match between COUNT and CCx, and the corresponding Match or Capture Channel x Interrupt Flag (INTFLAG.MCx) will be set.

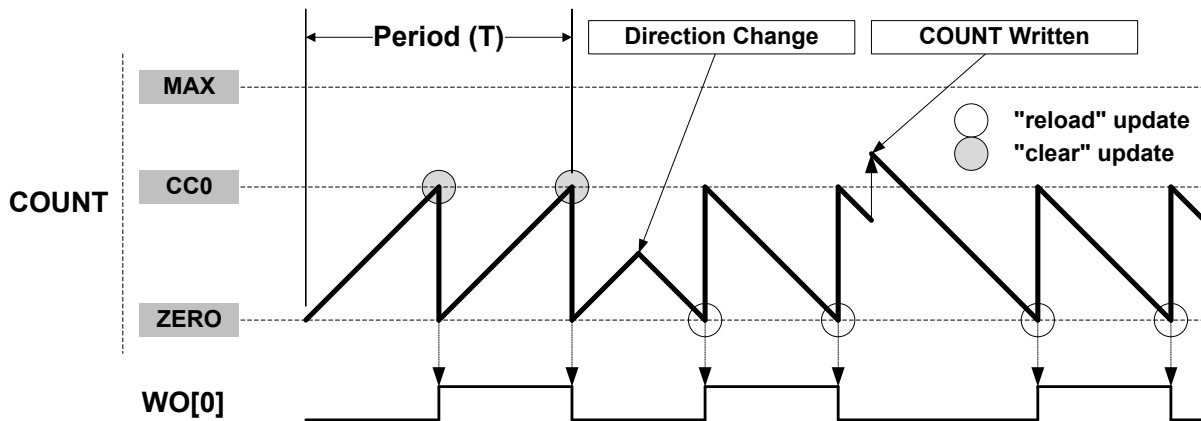
**Figure 48-4. Normal Frequency Operation**



**Match Frequency Generation (MFRQ)**

For Match Frequency Generation, the period time (T) is controlled by the CC0 register instead of PER or MAX. WO[0] toggles on each Update condition.

**Figure 48-5. Match Frequency Operation**



**Normal Pulse-Width Modulation Operation (NPWM)**

NPWM uses single-slope PWM generation.

For single-slope PWM generation, the period time (T) is controlled by the TOP value, and CCx controls the duty cycle of the generated waveform output. When up-counting, the WO[x] is set at start or compare match between the COUNT and TOP values, and cleared on compare match between COUNT and CCx register values. When down-counting, the WO[x] is cleared at start or compare match between the COUNT and ZERO values, and set on compare match between COUNT and CCx register values.

The following equation calculates the exact resolution for a single-slope PWM ( $R_{PWM\_SS}$ ) waveform:

$$R_{PWM\_SS} = \frac{\log(TOP+1)}{\log(2)}$$

The PWM frequency ( $f_{PWM\_SS}$ ) depends on TOP value and the peripheral clock frequency ( $f_{GCLK\_TC}$ ), and can be calculated by the following equation:

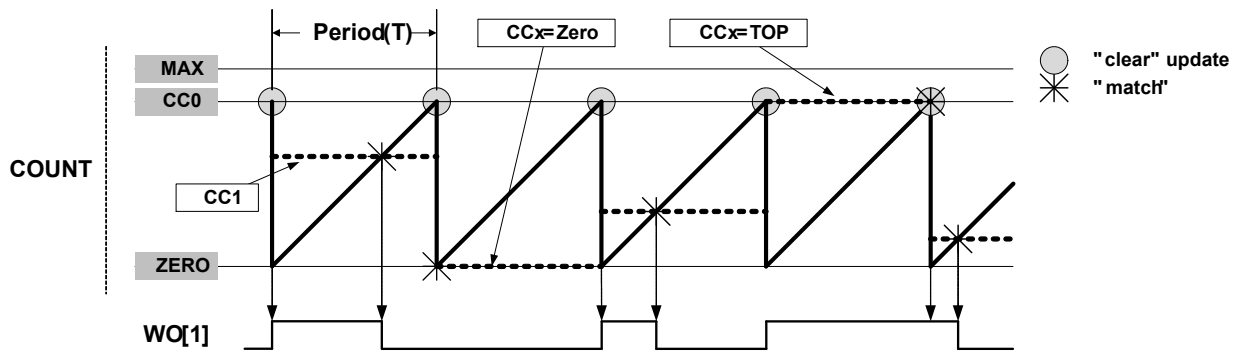
$$f_{PWM\_SS} = \frac{f_{GCLK\_TC}}{N(TOP+1)}$$

Where N represents the prescaler divider used (1, 2, 4, 8, 16, 64, 256, 1024).

**Match Pulse-Width Modulation Operation (MPWM)**

In MPWM, the output of WO[1] is depending on CC1 as shown in the figure below. On every overflow/underflow, a one-TC-clock-cycle negative pulse is put out on WO[0] (not shown in the figure).

**Figure 48-6. Match PWM Operation**



The table below shows the Update Counter and Overflow Event/Interrupt Generation conditions in different operation modes.

**Table 48-4. Counter Update and Overflow Event/interrupt Conditions in TC**

Name	Operation	TOP	Update	Output Waveform		OVFIF/Event	
				On Match	On Update	Up	Down
NFRQ	Normal Frequency	PER	TOP/ ZERO	Toggle	Stable	TOP	ZERO
MFRQ	Match Frequency	CC0	TOP/ ZERO	Toggle	Stable	TOP	ZERO
NPWM	Single-slope PWM	PER	TOP/ ZERO	See description above.		TOP	ZERO
MPWM	Single-slope PWM	CC0	TOP/ ZERO	Toggle	Toggle	TOP	ZERO

### Related Links

[32. PORT - I/O Pin Controller](#)

#### 48.6.2.7 Double Buffering

The Compare Channels (CCx) registers, and the Period (PER) register in 8-bit mode are double buffered. Each buffer register has a buffer valid bit (CCBUFVx or PERBUFV) in the STATUS register, which indicates that the buffer register contains a new valid value that can be copied into the corresponding register. As long as the respective buffer valid status flag (PERBUFV or CCBUFVx) are set to '1', related synchbusy bits are set (SYNCBUSY.PER or SYNCBUSY.CCx), a write to the respective PER/PERBUF or CCx/CCBUFx registers will generate a PAC error, and access to the respective PER or CCx register is invalid.

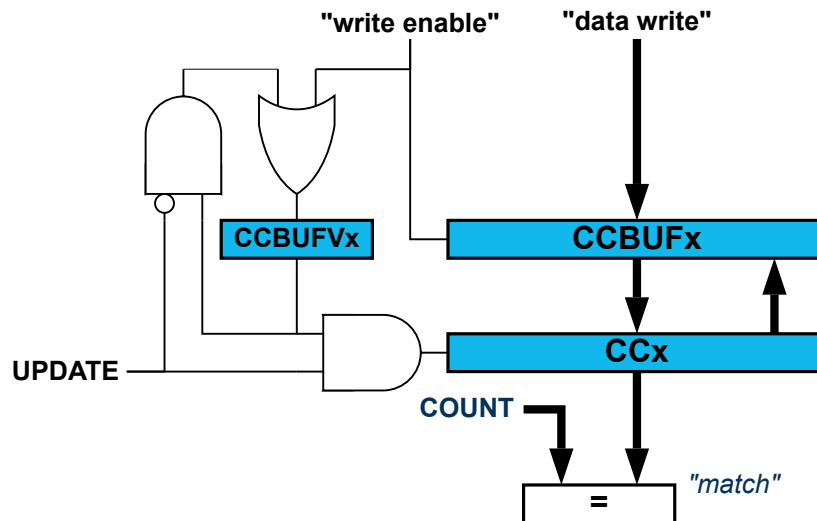
When the buffer valid flag bit in the STATUS register is '1' and the Lock Update bit in the CTRLB register is set to '0', (writing CTRLBCLR.LUPD to '1'), double buffering is enabled: the data from buffer registers will be copied into the corresponding register under hardware UPDATE conditions, then the buffer valid flags bit in the STATUS register are automatically cleared by hardware.

**Note:** The software update command (CTRLBSET.CMD=0x3) is acting independently of the LUPD value.

A compare register is double buffered as in the following figure.



**Figure 48-7. Compare Channel Double Buffering**



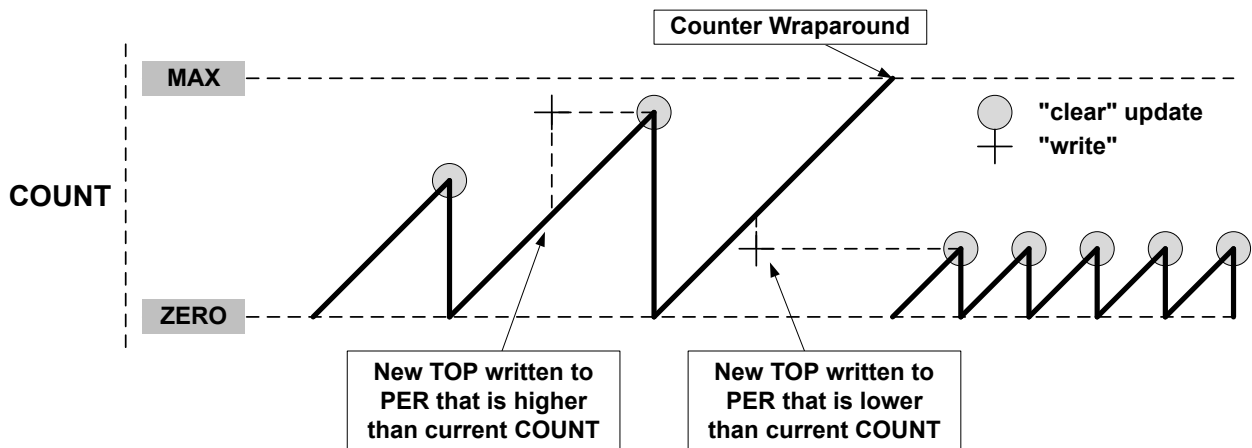
Both the registers (PER/CCx) and corresponding buffer registers (PERBUF/CCBUFx) are available in the I/O register map, and the double buffering feature is not mandatory. The double buffering is disabled by writing a '1' to CTRLBSET.LUPD.

**Note:** In NFRQ, MFRQ or PWM down-counting counter mode (CTRLBSET.DIR=1), when double buffering is enabled (CTRLBCLR.LUPD=1), PERBUF register is continuously copied into the PER independently of update conditions.

### Changing the Period

The counter period can be changed by writing a new TOP value to the Period register (PER or CC0, depending on the waveform generation mode), which is available in 8-bit mode. Any period update on registers (PER or CCx) is effective after the synchronization delay.

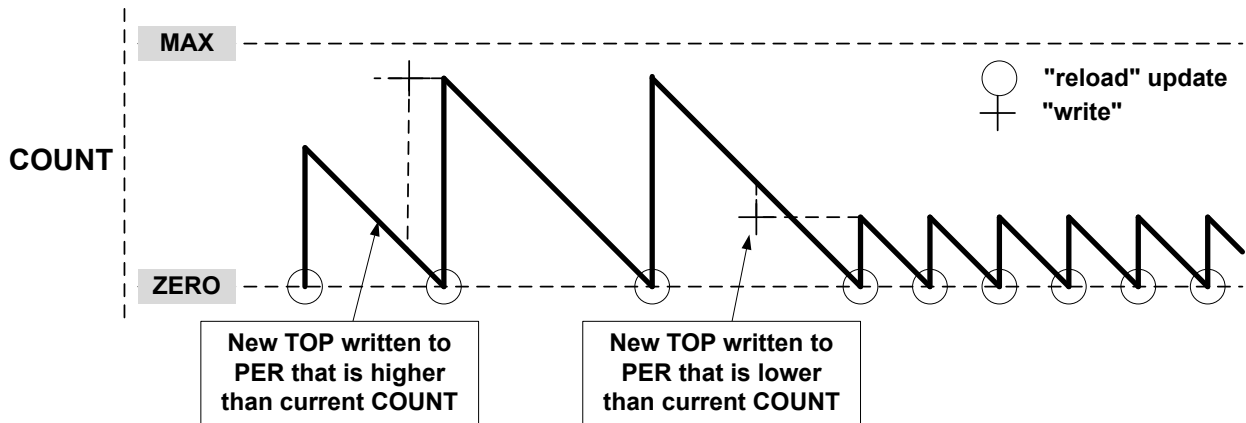
**Figure 48-8. Unbuffered Single-Slope Up-Counting Operation**



A counter wraparound can occur in any operation mode when up-counting without buffering, see [Figure 48-8](#).

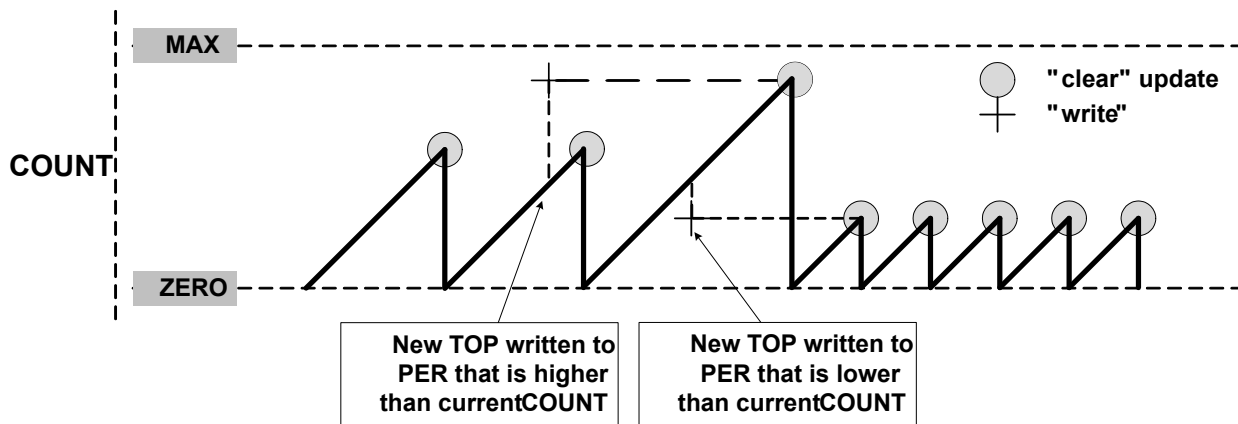
COUNT and TOP are continuously compared, so when a new TOP value that is lower than current COUNT is written to TOP, COUNT will wrap before a compare match.

**Figure 48-9. Unbuffered Single-Slope Down-Counting Operation**



When double buffering is used, the buffer can be written at any time and the counter will still maintain correct operation. The period register is always updated on the update condition, as shown in [Figure 48-10](#). This prevents wraparound and the generation of odd waveforms.

**Figure 48-10. Changing the Period Using Buffering**



### 48.6.2.8 Capture Operations

To enable and use capture operations, the corresponding Capture Channel x Enable bit in the Control A register (CTRLA.CAPTENx) must be written to '1'.

A capture trigger can be provided by input event line TC\_EV or by asynchronous IO pin WO[x] for each capture channel or by a TC event. To enable the capture from input event line, Event Input Enable bit in the Event Control register (EVCTRL.TCEI) must be written to '1'. To enable the capture from the IO pin, the Capture On Pin x Enable bit in CTRLA register (CTRLA.COPENx) must be written to '1'.

**Note:**

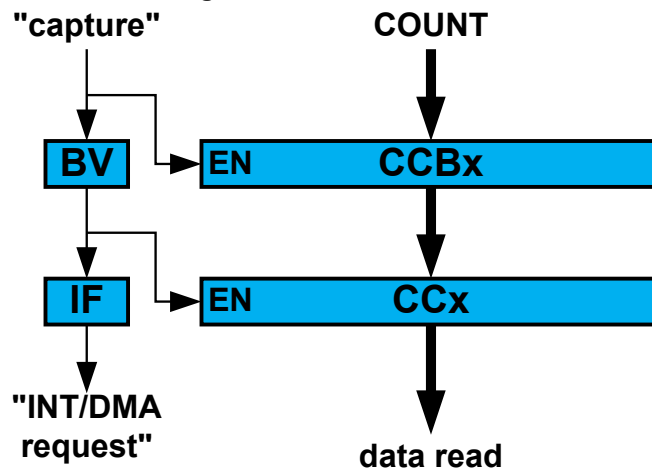
1. The RETRIGGER, COUNT and START event actions are available only on an event from the Event System.
2. Event system channels must be configured to operate in asynchronous mode of operation when used for capture operations.

By default, a capture operation is done when a rising edge is detected on the input signal. Capture on falling edge is available, its activation is depending on the input source:

- When the channel is used with a IO pin, write a '1' to the corresponding Invert Enable bit in the Drive Control register (DRVCTRL.INVENx).

- When the channel is counting events from the Event System, write a '1' to the TC Event Input Invert Enable bit in Event Control register (EVCTRL.TCINV).

**Figure 48-11. Capture Double Buffering**



For input capture, the buffer register and the corresponding CCx act like a FIFO. When CCx is empty or read, any content in CCBUFx is transferred to CCx. The buffer valid flag is passed to set the CCx interrupt flag (IF) and generate the optional interrupt, event or DMA request. The CCBUFx register value can't be read, all captured data must be read from CCx register.

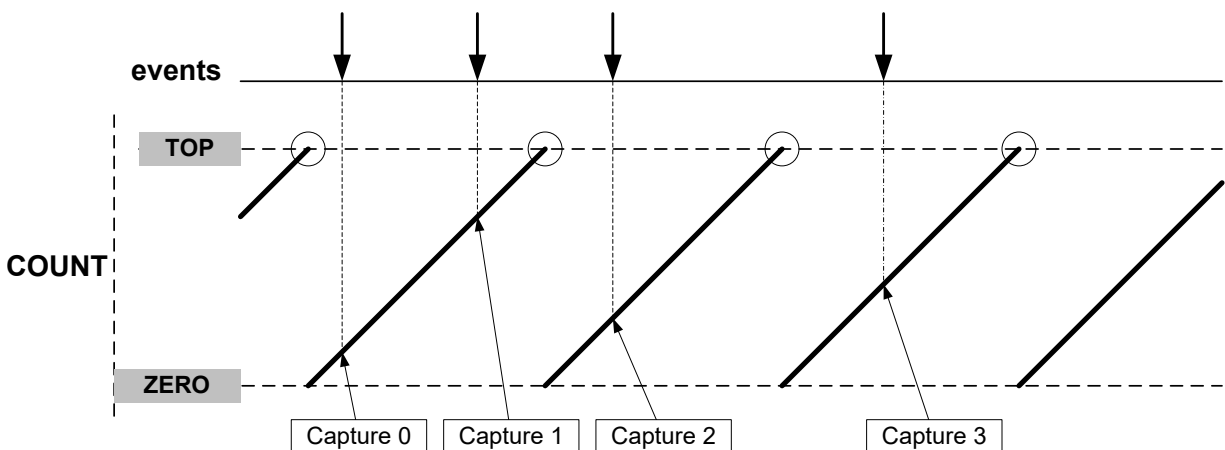
**Note:**

When up-counting (CTRLBSET.DIR=0), counter values lower than 1 cannot be captured. To capture the full range including value 0, the TC must be in down-counting mode (CTRLBSET.DIR=1).

**48.6.2.8.1 Event Capture Action**

The compare/capture channels can be used as input capture channels to capture events from the Event System and give them a timestamp. The following figure shows four capture events for one capture channel.

**Figure 48-12. Input Capture Timing**



The TC can detect capture overflow of the input capture channels: When a new capture event is detected while the Capture Interrupt flag (INTFLAG.MCx) is still set, the new timestamp will not be stored and INTFLAG.ERR will be set.

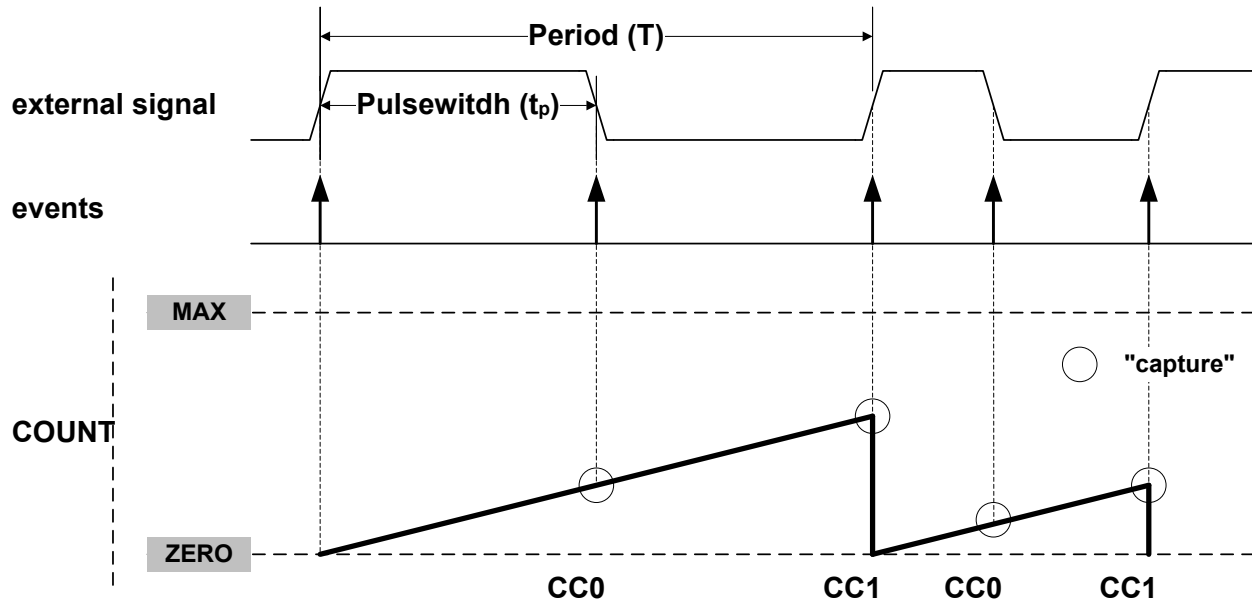
### 48.6.2.8.2 Period and Pulse-Width (PPW) Capture Action

The TC can perform two input captures and restart the counter on one of the edges. This enables the TC to measure the pulse width and period and to characterize the frequency  $f$  and duty cycle of an input signal:

$$f = \frac{1}{T}$$

$$\text{dutyCycle} = \frac{t_p}{T}$$

**Figure 48-13. PWP Capture**



Selecting PWP in the Event Action bit group in the Event Control register (EVCTRL.EVACT) enables the TC to perform one capture action on the rising edge and the other one on the falling edge. The period  $T$  will be captured into CC1 and the pulse width  $t_p$  in CC0. EVCTRL.EVACT=PPW (period and pulse-width) offers identical functionality, but will capture  $T$  into CC0 and  $t_p$  into CC1.

The TC Event Input Invert Enable bit in the Event Control register (EVCTRL.TCINV) is used to select whether the wraparound should occur on the rising edge or the falling edge. If EVCTRL.TCINV=1, the wraparound will happen on the falling edge. In case pin capture is enabled, this can also be achieved by modifying the value of the DRVCTRL.INVENx bit.

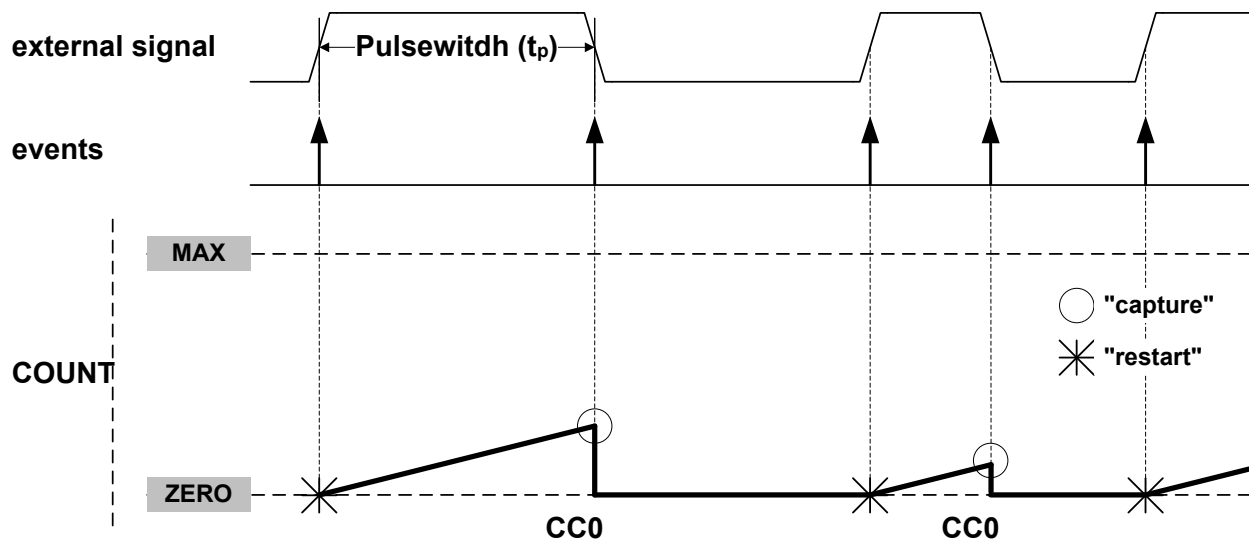
The TC can detect capture overflow of the input capture channels: When a new capture event is detected while the Capture Interrupt flag (INTFLAG.MCx) is still set, the new timestamp will not be stored and INTFLAG.ERR will be set.

**Note:** The corresponding capture is working only if the channel is enabled in capture mode (CTRLA.CAPTENx=1). If not, the capture action is ignored and the channel is enabled in compare mode of operation. Consequently, both channels must be enabled in order to fully characterize the input.

### 48.6.2.8.3 Pulse-Width Capture Action

The TC performs the input capture on the falling edge of the input signal. When the edge is detected, the counter value is cleared and the TC stops counting. When a rising edge is detected on the input signal, the counter restarts the counting operation. To enable the operation on opposite edges, the input signal to capture must be inverted (refer to DRVCTRL.INVEN or EVCTRL.TCEINV).

**Figure 48-14. Pulse-Width Capture on Channel 0**



The TC can detect capture overflow of the input capture channels: When a new capture event is detected while the Capture Interrupt flag (INTFLAG.MCx) is still set, the new timestamp will not be stored and INTFLAG.ERR will be set.

### 48.6.3 Additional Features

#### 48.6.3.1 One-Shot Operation

When one-shot is enabled, the counter automatically stops on the next Counter Overflow or Underflow condition. When the counter is stopped, the Stop bit in the Status register (STATUS.STOP) is automatically set and the waveform outputs are set to zero.

One-shot operation is enabled by writing a '1' to the One-Shot bit in the Control B Set register (CTRLBSET.ONESHOT), and disabled by writing a '0' to CTRLBCLR.ONESHOT. When enabled, the TC will count until an overflow or underflow occurs and stops counting operation. The one-shot operation can be restarted by a re-trigger software command, a re-trigger event, or a start event. When the counter restarts its operation, STATUS.STOP is automatically cleared.

#### 48.6.3.2 Time-Stamp Capture

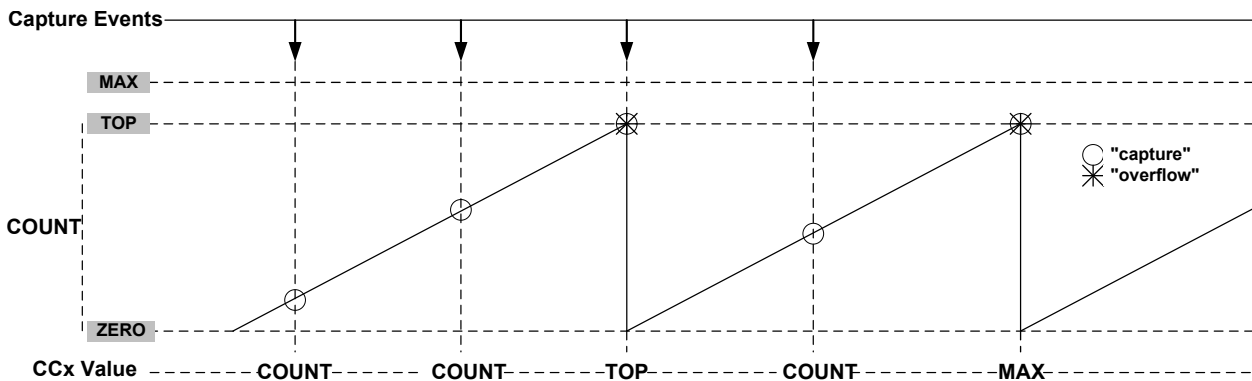
This feature is enabled when the Capture Time Stamp (STAMP) Event Action in Event Control register (EVCTRL.EVACT) is selected. The counter TOP value must be smaller than MAX.

When a capture event is detected, the COUNT value is copied into the corresponding Channel x Compare/Capture Value (CCx) register. In case of an overflow, the MAX value is copied into the corresponding CCx register.

When a valid captured value is present in the capture channel register, the corresponding Capture Channel x Interrupt Flag (INTFLAG.MCx) is set.

The timer/counter can detect capture overflow of the input capture channels: When a new capture event is detected while the Capture Channel interrupt flag (INTFLAG.MCx) is still set, the new time-stamp will not be stored and INTFLAG.ERR will be set.

**Figure 48-15. Time-Stamp**



### 48.6.3.3 Minimum Capture

The minimum capture is enabled by writing the CAPTMIN mode in the Channel n Capture Mode bits in the Control A register (CTRLA.CAPTMODEn = CAPTMIN).

*CCx Content:*

In CAPTMIN operations, CCx keeps the Minimum captured values. Before enabling this mode of capture, the user must initialize the corresponding CCx register value to a value different from zero. If the CCx register initial value is zero, no captures will be performed using the corresponding channel.

*MCx Behaviour:*

In CAPTMIN operation, capture is performed only when on capture event time, the counter value is lower than the last captured value. The MCx interrupt flag is set only when on capture event time, the counter value is upper or equal to the value captured on the previous event. So interrupt flag is set when a new absolute local Minimum value has been detected.

### 48.6.3.4 Maximum Capture

The maximum capture is enabled by writing the CAPTMAX mode in the Channel n Capture Mode bits in the Control A register (CTRLA.CAPTMODEn = CAPTMAX).

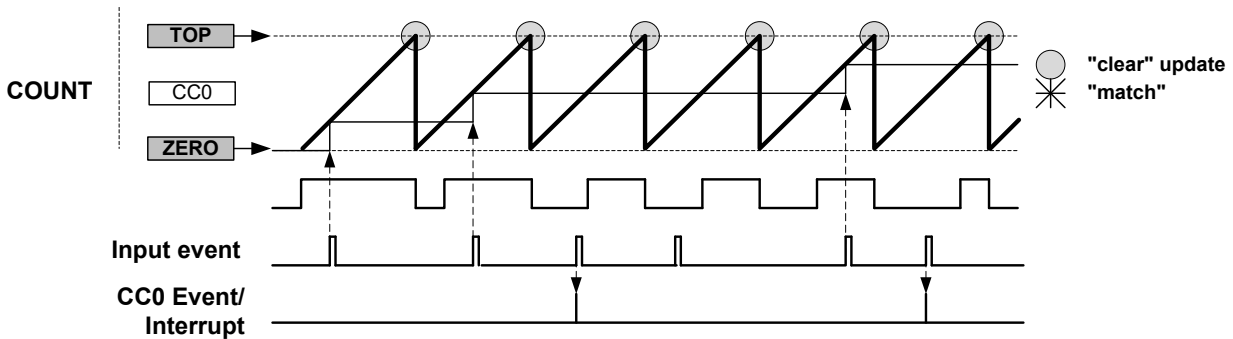
*CCx Content:*

In CAPTMAX operations, CCx keeps the Maximum captured values. Before enabling this mode of capture, the user must initialize the corresponding CCx register value to a value different from TOP. If the CCx register initial value is TOP, no captures will be performed using the corresponding channel.

*MCx Behaviour:*

In CAPTMAX operation, capture is performed only when on capture event time, the counter value is upper than the last captured value. The MCx interrupt flag is set only when on capture event time, the counter value is lower or equal to the value captured on the previous event. So interrupt flag is set when a new absolute local Maximum value has been detected.

**Figure 48-16. Maximum Capture Operation with CC0 Initialized with ZERO Value**



### 48.6.4 DMA Operation

The TC can generate the following DMA requests:

- Overflow (OVF): the request is set when an update condition (overflow, underflow or re-trigger) is detected, the request is cleared by hardware on DMA acknowledge.
- Match or Capture Channel x (MCx): for a compare channel, the request is set on each compare match detection, the request is cleared by hardware on DMA acknowledge. For a capture channel, the request is set when valid data is present in the CCx register, and cleared when CCx register is read.

### 48.6.5 Interrupts

The TC has the following interrupt sources:

- Overflow/Underflow (OVF)
- Match or Capture Channel x (MCx)
- Capture Overflow Error (ERR)

Each interrupt source has an interrupt flag associated with it. The interrupt flag in the Interrupt Flag Status and Clear register (INTFLAG) is set when the interrupt condition occurs.

Each interrupt can be individually enabled by writing a '1' to the corresponding bit in the Interrupt Enable Set register (INTENSET), and disabled by writing a '0' to the corresponding bit in the Interrupt Enable Clear register (INTENCLR).

An interrupt request is generated when the interrupt flag is set and the corresponding interrupt is enabled. The interrupt request remains active until either the interrupt flag is cleared, the interrupt is disabled, or the TC is reset. See [INTFLAG](#) for details on how to clear interrupt flags.

The TC has one common interrupt request line for all the interrupt sources. The user must read the INTFLAG register to determine which interrupt condition is present.

Note that interrupts must be globally enabled for interrupt requests to be generated. Refer to *Nested Vector Interrupt Controller* for details.

### Related Links

[10.2 Nested Vector Interrupt Controller](#)

### 48.6.6 Events

The TC can generate the following output events:

- Overflow/Underflow (OVF)
- Match or Capture Channel x (MCx)

---

Writing a '1' to an Event Output bit in the Event Control register (EVCTRL.MCEOx) enables the corresponding output event. The output event is disabled by writing EVCTRL.MCEOx=0.

One of the following event actions can be selected by the Event Action bit group in the Event Control register (EVCTRL.EVACT):

- Disable event action (OFF)
- Start TC (START)
- Re-trigger TC (RETRIGGER)
- Count on event (COUNT)
- Capture time stamp (STAMP)
- Capture Period (PPW and PWP)
- Capture Pulse Width (PW)

Writing a '1' to the TC Event Input bit in the Event Control register (EVCTRL.TCEI) enables input events to the TC. Writing a '0' to this bit disables input events to the TC. The TC requires only asynchronous event inputs. For further details on how configuring the asynchronous events, refer to *EVSYS - Event System*.

### Related Links

[31. EVSYS – Event System](#)

#### 48.6.7 Sleep Mode Operation

The TC can be configured to operate in any sleep mode. To be able to run in standby, the RUNSTDBY bit in the Control A register (CTRLA.RUNSTDBY) must be '1'. This peripheral can wake up the device from any sleep mode using interrupts or perform actions through the Event System.

If the On Demand bit in the Control A register (CTRLA.ONDEMAND) is written to '1', the module stops requesting its peripheral clock when the STOP bit in STATUS register (STATUS.STOP) is set to '1'. When a re-trigger or start condition is detected, the TC requests the clock before the operation starts.

#### 48.6.8 Synchronization

Due to asynchronicity between the main clock domain and the peripheral clock domains, some registers need to be synchronized when written or read.

The following bits are synchronized when written:

- Software Reset and Enable bits in Control A register (CTRLA.SWRST and CTRLA.ENABLE)
- Capture Channel Buffer Valid bit in STATUS register (STATUS.CCBUFVx)

The following registers are synchronized when written:

- Control B Clear and Control B Set registers (CTRLBCLR and CTRLBSET)
- Count Value register (COUNT)
- Period Value and Period Buffer Value registers (PER and PERBUF)
- Channel x Compare/Capture Value and Channel x Compare/Capture Buffer Value registers (CCx and CCBUFx)

The following registers are synchronized when read:

- Count Value register (COUNT): synchronization is done on demand through READSYNC command (CTRLBSET.CMD).

Required write synchronization is denoted by the "Write-Synchronized" property in the register description.



Required read synchronization is denoted by the "Read-Synchronized" property in the register description.

### 48.7 Register Description

Registers can be 8, 16, or 32 bits wide. Atomic 8-, 16- and 32-bit accesses are supported. In addition, the 8-bit quarters and 16-bit halves of a 32-bit register, and the 8-bit halves of a 16-bit register can be accessed directly.

Some registers are optionally write-protected by the Peripheral Access Controller (PAC). Optional PAC write protection is denoted by the "PAC Write-Protection" property in each individual register description. For details, refer to [Register Access Protection](#).

Some registers are synchronized when read and/or written. Synchronization is denoted by the "Write-Synchronized" or the "Read-Synchronized" property in each individual register description. For details, refer to [Synchronization](#).

Some registers are enable-protected, meaning they can only be written when the peripheral is disabled. Enable-protection is denoted by the "Enable-Protected" property in each individual register description.

# SAM D5x/E5x Family Data Sheet

## TC – Timer/Counter

### 48.7.1 Register Summary - 8-bit Mode

Offset	Name	Bit Pos.									
0x00	CTRLA	7:0	ONDEMAND	RUNSTDBY	PRESCSYNC[1:0]		MODE[1:0]		ENABLE	SWRST	
		15:8	DMAOS				ALOCK	PRESCALER[2:0]			
		23:16			COPEN1	COPEN0			CAPTEN1	CAPTEN0	
		31:24				CAPTMODE1[1:0]			CAPTMODE0[1:0]		
0x04	CTRLBCLR	7:0	CMD[2:0]				ONESHOT	LUPD	DIR		
0x05	CTRLBSET	7:0	CMD[2:0]				ONESHOT	LUPD	DIR		
0x06	EVCTRL	7:0			TCEI	TCINV		EVACT[2:0]			
		15:8			MCEO1	MCEO0			OVFEO		
0x08	INTENCLR	7:0			MC1	MC0		ERR	OVF		
0x09	INTENSET	7:0			MC1	MC0		ERR	OVF		
0x0A	INTFLAG	7:0			MC1	MC0		ERR	OVF		
0x0B	STATUS	7:0			CCBUFV1	CCBUFV0	PERBUFV	SLAVE	STOP		
0x0C	WAVE	7:0						WAVEGEN[1:0]			
0x0D	DRVCTRL	7:0						INVEN1	INVEN0		
0x0E	Reserved										
0x0F	DBGCTRL	7:0							DBGRUN		
0x10	SYNCBUSY	7:0	CC1	CC0		COUNT	STATUS	CTRLB	ENABLE	SWRST	
		15:8									
		23:16									
		31:24									
0x14	COUNT	7:0	COUNT[7:0]								
0x15	Reserved										
...											
0x1A											
0x1B	PER	7:0	PER[7:0]								
0x1C	CC0	7:0	CC[7:0]								
0x1D	CC1	7:0	CC[7:0]								
0x1E	Reserved										
...											
0x2E											
0x2F	PERBUF	7:0	PERBUF[7:0]								
0x30	CCBUF0	7:0	CCBUF[7:0]								
0x31	CCBUF1	7:0	CCBUF[7:0]								

# SAM D5x/E5x Family Data Sheet

## TC – Timer/Counter

### 48.7.1.1 Control A

**Name:** CTRLA  
**Offset:** 0x00  
**Reset:** 0x00000000  
**Property:** PAC Write-Protection, Write-Synchronized, Enable-Protected

Bit	31	30	29	28	27	26	25	24
				CAPTMODE1[1:0]				
Access				R/W	R/W			R/W
Reset				0	0			0
Bit	23	22	21	20	19	18	17	16
			COPEN1	COPEN0			CAPTEN1	CAPTEN0
Access			R/W	R/W			R/W	R/W
Reset			0	0			0	0
Bit	15	14	13	12	11	10	9	8
	DMAOS					ALOCK	PRESCALER[2:0]	
Access	R/W					R/W	R/W	R/W
Reset	0					0	0	0
Bit	7	6	5	4	3	2	1	0
	ONDEMAND	RUNSTDBY	PRESCSYNC[1:0]		MODE[1:0]		ENABLE	SWRST
Access	R/W	R/W	R/W	R/W	R/W	R/W	R/W	W
Reset	0	0	0	0	0	0	0	0

#### Bits 28:27 – CAPTMODE1[1:0] Capture mode Channel 1

These bits select the channel 1 capture mode.

Value	Name	Description
0x0	DEFAULT	Default capture
0x1	CAPTMIN	Minimum capture
0x2	CAPTMAX	Maximum capture
0x3		Reserved

#### Bits 25:24 – CAPTMODE0[1:0] Capture mode Channel 0

These bits select the channel 0 capture mode.

Value	Name	Description
0x0	DEFAULT	Default capture
0x1	CAPTMIN	Minimum capture
0x2	CAPTMAX	Maximum capture
0x3		Reserved

#### Bits 20, 21 – COPENx Capture On Pin x Enable

Bit x of COPEN[1:0] selects the trigger source for capture operation, either events or I/O pin input.

Value	Description
0	Event from Event System is selected as trigger source for capture operation on channel x.
1	I/O pin is selected as trigger source for capture operation on channel x.

### Bits 16, 17 – CAPTEN<sub>x</sub> Capture Channel x Enable

Bit x of CAPTEN[1:0] selects whether channel x is a capture or a compare channel.

These bits are not synchronized.

Value	Description
0	CAPTEN disables capture on channel x.
1	CAPTEN enables capture on channel x.

### Bit 15 – DMAOS DMA One-Shot Trigger Mode

This bit enables the DMA One-shot Trigger Mode.

Writing a '1' to this bit will generate a DMA trigger on TC cycle following a TC\_CTRLBSET\_CMD\_DMAOS command.

Writing a '0' to this bit will generate DMA triggers on each TC cycle.

This bit is not synchronized.

### Bit 11 – ALOCK Auto Lock

When this bit is set, Lock bit update (LUPD) is set to '1' on each overflow/underflow or re-trigger event.

This bit is not synchronized.

Value	Description
0	The LUPD bit is not affected on overflow/underflow, and re-trigger event.
1	The LUPD bit is set on each overflow/underflow or re-trigger event.

### Bits 10:8 – PRESCALER[2:0] Prescaler

These bits select the counter prescaler factor.

These bits are not synchronized.

Value	Name	Description
0x0	DIV1	Prescaler: GCLK_TC
0x1	DIV2	Prescaler: GCLK_TC/2
0x2	DIV4	Prescaler: GCLK_TC/4
0x3	DIV8	Prescaler: GCLK_TC/8
0x4	DIV16	Prescaler: GCLK_TC/16
0x5	DIV64	Prescaler: GCLK_TC/64
0x6	DIV256	Prescaler: GCLK_TC/256
0x7	DIV1024	Prescaler: GCLK_TC/1024

### Bit 7 – ONDEMAND Clock On Demand

This bit selects the clock requirements when the TC is stopped.

In standby mode, if the Run in Standby bit (CTRLA.RUNSTDBY) is '0', ONDEMAND is forced to '0'.

This bit is not synchronized.

Value	Description
0	The On Demand is disabled. If On Demand is disabled, the TC will continue to request the clock when its operation is stopped (STATUS.STOP=1).
1	The On Demand is enabled. When On Demand is enabled, the stopped TC will not request the clock. The clock is requested when a software re-trigger command is applied or when an event with start/re-trigger action is detected.

### Bit 6 – RUNSTDBY Run in Standby

This bit is used to keep the TC running in standby mode.

This bit is not synchronized.

Value	Description
0	The TC is halted in standby.
1	The TC continues to run in standby.

### Bits 5:4 – PRESCSYNC[1:0] Prescaler and Counter Synchronization

These bits select whether the counter should wrap around on the next GCLK\_TCx clock or the next prescaled GCLK\_TCx clock. It also makes it possible to reset the prescaler.

These bits are not synchronized.

Value	Name	Description
0x0	GCLK	Reload or reset the counter on next generic clock
0x1	PRESC	Reload or reset the counter on next prescaler clock
0x2	RESYNC	Reload or reset the counter on next generic clock. Reset the prescaler counter
0x3	-	Reserved

### Bits 3:2 – MODE[1:0] Timer Counter Mode

These bits select the counter mode.

These bits are not synchronized.

Value	Name	Description
0x0	COUNT16	Counter in 16-bit mode
0x1	COUNT8	Counter in 8-bit mode
0x2	COUNT32	Counter in 32-bit mode
0x3	-	Reserved

### Bit 1 – ENABLE Enable

Due to synchronization, there is delay from writing CTRLA.ENABLE until the peripheral is enabled/disabled. The value written to CTRLA.ENABLE will read back immediately, and the ENABLE Synchronization Busy bit in the SYNCBUSY register (SYNCBUSY.ENABLE) will be set.

SYNCBUSY.ENABLE will be cleared when the operation is complete.

This bit is not enable protected.

Value	Description
0	The peripheral is disabled.
1	The peripheral is enabled.

### Bit 0 – SWRST Software Reset

Writing a '0' to this bit has no effect.

Writing a '1' to this bit resets all registers in the TC, except DBGCTRL, to their initial state, and the TC will be disabled.

Writing a '1' to CTRLA.SWRST will always take precedence; all other writes in the same write-operation will be discarded.

### 48.7.1.2 Control B Clear

**Name:** CTRLBCLR  
**Offset:** 0x04  
**Reset:** 0x00  
**Property:** PAC Write-Protection, Read-Synchronized, Write-Synchronized

This register allows the user to clear bits in the CTRLB register without doing a read-modify-write operation. Changes in this register will also be reflected in the Control B Set register (CTRLBSET).

Bit	7	6	5	4	3	2	1	0
	CMD[2:0]					ONESHOT	LUPD	DIR
Access	R/W	R/W	R/W			R/W	R/W	R/W
Reset	0	0	0			0	0	0

#### Bits 7:5 – CMD[2:0] Command

These bits are used for software control of the TC. The commands are executed on the next prescaled GCLK\_TC clock cycle. When a command has been executed, the CMD bit group will be read back as zero.

Writing 0x0 to these bits has no effect.

Writing a '1' to any of these bits will clear the pending command.

#### Bit 2 – ONESHOT One-Shot on Counter

This bit controls one-shot operation of the TC.

Writing a '0' to this bit has no effect

Writing a '1' to this bit will disable one-shot operation.

Value	Description
0	The TC will wrap around and continue counting on an overflow/underflow condition.
1	The TC will wrap around and stop on the next underflow/overflow condition.

#### Bit 1 – LUPD Lock Update

This bit controls the update operation of the TC buffered registers.

When CTRLB.LUPD is set, no any update of the registers with value of its buffered register is performed on hardware UPDATE condition. Locking the update ensures that all buffer registers are valid before an hardware update is performed. After all the buffer registers are loaded correctly, the buffered registers can be unlocked.

This bit has no effect when input capture operation is enabled.

Writing a '0' to this bit has no effect.

Writing a '1' to this bit will clear the LUPD bit.

Value	Description
0	The CCBUFx and PERBUF buffer registers value are copied into CCx and PER registers on hardware update condition.
1	The CCBUFx and PERBUF buffer registers value are not copied into CCx and PER registers on hardware update condition.

#### Bit 0 – DIR Counter Direction

This bit is used to change the direction of the counter.

Writing a '0' to this bit has no effect.

Writing a '1' to this bit will clear the bit and make the counter count up.

# SAM D5x/E5x Family Data Sheet

## TC – Timer/Counter

---

---

Value	Description
0	The timer/counter is counting up (incrementing).
1	The timer/counter is counting down (decrementing).

### 48.7.1.3 Control B Set

**Name:** CTRLBSET  
**Offset:** 0x05  
**Reset:** 0x00  
**Property:** PAC Write-Protection, Read-synchronized, Write-Synchronized

This register allows the user to set bits in the CTRLB register without doing a read-modify-write operation. Changes in this register will also be reflected in the Control B Clear register (CTRLBCLR).

	7	6	5	4	3	2	1	0
	CMD[2:0]					ONESHOT	LUPD	DIR
Access	R/W	R/W	R/W			R/W	R/W	R/W
Reset	0	0	0			0	0	0

#### Bits 7:5 – CMD[2:0] Command

These bits are used for software control of the TC. The commands are executed on the next prescaled GCLK\_TC clock cycle. When a command has been executed, the CMD bit group will be read back as zero.

Writing 0x0 to these bits has no effect.

Writing a value different from 0x0 to these bits will issue a command for execution.

Value	Name	Description
0x0	NONE	No action
0x1	RETRIGGER	Force a start, restart or retrigger
0x2	STOP	Force a stop
0x3	UPDATE	Force update of double buffered registers
0x4	READSYNC	Force a read synchronization of COUNT

#### Bit 2 – ONESHOT One-Shot on Counter

This bit controls one-shot operation of the TC.

Writing a '0' to this bit has no effect.

Writing a '1' to this bit will enable one-shot operation.

Value	Description
0	The TC will wrap around and continue counting on an overflow/underflow condition.
1	The TC will wrap around and stop on the next underflow/overflow condition.

#### Bit 1 – LUPD Lock Update

This bit controls the update operation of the TC buffered registers.

When CTRLB.LUPD is set, no any update of the registers with value of its buffered register is performed on hardware UPDATE condition. Locking the update ensures that all buffer registers are valid before an hardware update is performed. After all the buffer registers are loaded correctly, the buffered registers can be unlocked.

Writing a '0' to this bit has no effect.

Writing a '1' to this bit will set the LUPD bit.

This bit has no effect when input capture operation is enabled.

Value	Description
0	The CCBUFx and PERBUF buffer registers value are copied into CCx and PER registers on hardware update condition.



---

---

Value	Description
1	The CCBUFx and PERBUF buffer registers value are not copied into CCx and PER registers on hardware update condition.

### Bit 0 – DIR Counter Direction

This bit is used to change the direction of the counter.

Writing a '0' to this bit has no effect

Writing a '1' to this bit will clear the bit and make the counter count up.

Value	Description
0	The timer/counter is counting up (incrementing).
1	The timer/counter is counting down (decrementing).

### 48.7.1.4 Event Control

**Name:** EVCTRL  
**Offset:** 0x06  
**Reset:** 0x0000  
**Property:** PAC Write-Protection, Enable-Protected

	Bit	15	14	13	12	11	10	9	8
				MCEO1	MCEO0				OVFEO
Access				R/W	R/W				R/W
Reset				0	0				0
	Bit	7	6	5	4	3	2	1	0
				TCEI	TCINV		EVACT[2:0]		
Access				R/W	R/W		R/W	R/W	R/W
Reset				0	0		0	0	0

#### Bit 13 – MCEO1 Match or Capture Channel x Event Output Enable [x = 1..0]

These bits enable the generation of an event for every match or capture on channel x.

Value	Description
0	Match/Capture event on channel x is disabled and will not be generated.
1	Match/Capture event on channel x is enabled and will be generated for every compare/capture.

#### Bit 12 – MCEO0 Match or Capture Channel x Event Output Enable [x = 1..0]

These bits enable the generation of an event for every match or capture on channel x.

Value	Description
0	Match/Capture event on channel x is disabled and will not be generated.
1	Match/Capture event on channel x is enabled and will be generated for every compare/capture.

#### Bit 8 – OVFEO Overflow/Underflow Event Output Enable

This bit enables the Overflow/Underflow event. When enabled, an event will be generated when the counter overflows/underflows.

Value	Description
0	Overflow/Underflow event is disabled and will not be generated.
1	Overflow/Underflow event is enabled and will be generated for every counter overflow/underflow.

#### Bit 5 – TCEI TC Event Enable

This bit is used to enable asynchronous input events to the TC.

Value	Description
0	Incoming events are disabled.
1	Incoming events are enabled.

#### Bit 4 – TCINV TC Inverted Event Input Polarity

This bit inverts the asynchronous input event source.

Value	Description
0	Input event source is not inverted.

Value	Description
1	Input event source is inverted.

### Bits 2:0 – EVACT[2:0] Event Action

These bits define the event action the TC will perform on an event.

Value	Name	Description
0x0	OFF	Event action disabled
0x1	RETRIGGER	Start, restart or retrigger TC on event
0x2	COUNT	Count on event
0x3	START	Start TC on event
0x4	STAMP	Time stamp capture
0x5	PPW	Period captured in CC0, pulse width in CC1
0x6	PWP	Period captured in CC1, pulse width in CC0
0x7	PW	Pulse width capture

### 48.7.1.5 Interrupt Enable Clear

**Name:** INTENCLR  
**Offset:** 0x08  
**Reset:** 0x00  
**Property:** PAC Write-Protection

This register allows the user to disable an interrupt without doing a read-modify-write operation. Changes in this register will also be reflected in the Interrupt Enable Set register (INTENSET).

	7	6	5	4	3	2	1	0
			MC1	MC0			ERR	OVF
Access			R/W	R/W			R/W	R/W
Reset			0	0			0	0

#### Bit 5 – MC1 Match or Capture Channel x Interrupt Enable

Writing a '0' to these bits has no effect.

Writing a '1' to MCx will clear the corresponding Match or Capture Channel x Interrupt Enable bit, which disables the Match or Capture Channel x interrupt.

Value	Description
0	The Match or Capture Channel x interrupt is disabled.
1	The Match or Capture Channel x interrupt is enabled.

#### Bit 4 – MC0 Match or Capture Channel x Interrupt Enable

Writing a '0' to these bits has no effect.

Writing a '1' to MCx will clear the corresponding Match or Capture Channel x Interrupt Enable bit, which disables the Match or Capture Channel x interrupt.

Value	Description
0	The Match or Capture Channel x interrupt is disabled.
1	The Match or Capture Channel x interrupt is enabled.

#### Bit 1 – ERR Error Interrupt Disable

Writing a '0' to this bit has no effect.

Writing a '1' to this bit will clear the Error Interrupt Enable bit, which disables the Error interrupt.

Value	Description
0	The Error interrupt is disabled.
1	The Error interrupt is enabled.

#### Bit 0 – OVF Overflow Interrupt Disable

Writing a '0' to this bit has no effect.

Writing a '1' to this bit will clear the Overflow Interrupt Enable bit, which disables the Overflow interrupt request.

Value	Description
0	The Overflow interrupt is disabled.
1	The Overflow interrupt is enabled.

### 48.7.1.6 Interrupt Enable Set

**Name:** INTENSET  
**Offset:** 0x09  
**Reset:** 0x00  
**Property:** PAC Write-Protection

This register allows the user to enable an interrupt without doing a read-modify-write operation. Changes in this register will also be reflected in the Interrupt Enable Clear register (INTENCLR).

	7	6	5	4	3	2	1	0
			MC1	MC0			ERR	OVF
Access			R/W	R/W			R/W	R/W
Reset			0	0			0	0

#### Bit 5 – MC1 Match or Capture Channel x Interrupt Enable

Writing a '0' to these bits has no effect.

Writing a '1' to MCx will set the corresponding Match or Capture Channel x Interrupt Enable bit, which enables the Match or Capture Channel x interrupt.

Value	Description
0	The Match or Capture Channel x interrupt is disabled.
1	The Match or Capture Channel x interrupt is enabled.

#### Bit 4 – MC0 Match or Capture Channel x Interrupt Enable

Writing a '0' to these bits has no effect.

Writing a '1' to MCx will set the corresponding Match or Capture Channel x Interrupt Enable bit, which enables the Match or Capture Channel x interrupt.

Value	Description
0	The Match or Capture Channel x interrupt is disabled.
1	The Match or Capture Channel x interrupt is enabled.

#### Bit 1 – ERR Error Interrupt Enable

Writing a '0' to this bit has no effect.

Writing a '1' to this bit will set the Error Interrupt Enable bit, which enables the Error interrupt.

Value	Description
0	The Error interrupt is disabled.
1	The Error interrupt is enabled.

#### Bit 0 – OVF Overflow Interrupt Enable

Writing a '0' to this bit has no effect.

Writing a '1' to this bit will set the Overflow Interrupt Enable bit, which enables the Overflow interrupt request.

Value	Description
0	The Overflow interrupt is disabled.
1	The Overflow interrupt is enabled.

### 48.7.1.7 Interrupt Flag Status and Clear

**Name:** INTFLAG  
**Offset:** 0x0A  
**Reset:** 0x00  
**Property:** -

	7	6	5	4	3	2	1	0
Access			R/W	R/W			R/W	R/W
Reset			0	0			0	0

#### Bit 5 – MC1 Match or Capture Channel x

This flag is set on a comparison match, or when the corresponding CCx register contains a valid capture value. This flag is set on the next CLK\_TC\_CNT cycle, and will generate an interrupt request if the corresponding Match or Capture Channel x Interrupt Enable bit in the Interrupt Enable Set register (INTENSET.MCx) is '1'.

Writing a '0' to one of these bits has no effect.

Writing a '1' to one of these bits will clear the corresponding Match or Capture Channel x interrupt flag. In capture operation, this flag is automatically cleared when CCx register is read.

#### Bit 4 – MC0 Match or Capture Channel x

This flag is set on a comparison match, or when the corresponding CCx register contains a valid capture value. This flag is set on the next CLK\_TC\_CNT cycle, and will generate an interrupt request if the corresponding Match or Capture Channel x Interrupt Enable bit in the Interrupt Enable Set register (INTENSET.MCx) is '1'.

Writing a '0' to one of these bits has no effect.

Writing a '1' to one of these bits will clear the corresponding Match or Capture Channel x interrupt flag. In capture operation, this flag is automatically cleared when CCx register is read.

#### Bit 1 – ERR Error Interrupt Flag

This flag is set when a new capture occurs on a channel while the corresponding Match or Capture Channel x interrupt flag is set, in which case there is nowhere to store the new capture.

Writing a '0' to this bit has no effect.

Writing a '1' to this bit clears the Error interrupt flag.

#### Bit 0 – OVF Overflow Interrupt Flag

This flag is set on the next CLK\_TC\_CNT cycle after an overflow condition occurs, and will generate an interrupt request if INTENCLR.OVF or INTENSET.OVF is '1'.

Writing a '0' to this bit has no effect.

Writing a '1' to this bit clears the Overflow interrupt flag.

# SAM D5x/E5x Family Data Sheet

## TC – Timer/Counter

### 48.7.1.8 Status

**Name:** STATUS  
**Offset:** 0x0B  
**Reset:** 0x01  
**Property:** Read-Synchronized

	7	6	5	4	3	2	1	0
			CCBUFV1	CCBUFV0	PERBUFV		SLAVE	STOP
Access			R/W	R/W	R/W		R	R
Reset			0	0	0		0	1

#### Bits 4, 5 – CCBUFV Channel x Compare or Capture Buffer Valid

For a compare channel x, the bit x is set when a new value is written to the corresponding CCBUFx register.

The bit x is cleared by writing a '1' to it when CTRLB.LUPD is set, or it is cleared automatically by hardware on UPDATE condition.

For a capture channel x, the bit x is set when a valid capture value is stored in the CCBUFx register. The bit x is cleared automatically when the CCx register is read.

#### Bit 3 – PERBUFV Period Buffer Valid

This bit is set when a new value is written to the PERBUF register. The bit is cleared by writing '1' to the corresponding location when CTRLB.LUPD is set, or automatically cleared by hardware on UPDATE condition. This bit is available only in 8-bit mode and will always read zero in 16- and 32-bit modes.

#### Bit 1 – SLAVE Slave Status Flag

This bit is only available in 32-bit mode on the slave TC (i.e., TC1 and/or TC3). The bit is set when the associated master TC (TC0 and TC2, respectively) is set to run in 32-bit mode.

#### Bit 0 – STOP Stop Status Flag

This bit is set when the TC is disabled, on a Stop command, or on an overflow/underflow condition when the One-Shot bit in the Control B Set register (CTRLBSET.ONESHOT) is '1'.

Value	Description
0	Counter is running.
1	Counter is stopped.

# SAM D5x/E5x Family Data Sheet

## TC – Timer/Counter

### 48.7.1.9 Waveform Generation Control

**Name:** WAVE  
**Offset:** 0x0C  
**Reset:** 0x00  
**Property:** PAC Write-Protection, Enable-Protected

Bit	7	6	5	4	3	2	1	0
							WAVEGEN[1:0]	
Access							R/W	R/W
Reset							0	0

#### Bits 1:0 – WAVEGEN[1:0] Waveform Generation Mode

These bits select the waveform generation operation. They affect the top value, as shown in [48.6.2.6.1 Waveform Output Operations](#). They also control whether frequency or PWM waveform generation should be used. The waveform generation operations are explained in [48.6.2.6.1 Waveform Output Operations](#). These bits are not synchronized.

Value	Name	Operation	Top Value	Output Waveform on Match	Output Waveform on Wraparound
0x0	NFRQ	Normal frequency	PER <sup>1</sup> / Max	Toggle	No action
0x1	MFRQ	Match frequency	CC0	Toggle	No action
0x2	NPWM	Normal PWM	PER <sup>1</sup> / Max	Set	Clear
0x3	MPWM	Match PWM	CC0	Set	Clear

1) This depends on the TC mode: In 8-bit mode, the top value is the Period Value register (PER). In 16- and 32-bit mode it is the respective MAX value.



### 48.7.1.10 Driver Control

**Name:** DRVCTRL  
**Offset:** 0x0D  
**Reset:** 0x00  
**Property:** PAC Write-Protection, Enable-Protected

	Bit	7	6	5	4	3	2	1	0
								INVEN1	INVEN0
Access								R/W	R/W
Reset								0	0

**Bits 0, 1 – INVENx** Output Waveform x Invert Enable

Bit x of INVEN[1:0] selects inversion of the output or capture trigger input of channel x.

Value	Description
0	Disable inversion of the WO[x] output and IO input pin.
1	Enable inversion of the WO[x] output and IO input pin.

# SAM D5x/E5x Family Data Sheet

## TC – Timer/Counter

### 48.7.1.11 Debug Control

**Name:** DBGCTRL  
**Offset:** 0x0F  
**Reset:** 0x00  
**Property:** PAC Write-Protection

Bit	7	6	5	4	3	2	1	0
								DBGRUN
Access								R/W
Reset								0

#### Bit 0 – DBGRUN Run in Debug Mode

This bit is not affected by a software Reset, and should not be changed by software while the TC is enabled.

Value	Description
0	The TC is halted when the device is halted in debug mode.
1	The TC continues normal operation when the device is halted in debug mode.

### 48.7.1.12 Synchronization Busy

**Name:** SYNCBUSY  
**Offset:** 0x10  
**Reset:** 0x00000000  
**Property:** -

Bit	31	30	29	28	27	26	25	24
Access								
Reset								
Bit	23	22	21	20	19	18	17	16
Access								
Reset								
Bit	15	14	13	12	11	10	9	8
Access								
Reset								
Bit	7	6	5	4	3	2	1	0
	CC1	CC0		COUNT	STATUS	CTRLB	ENABLE	SWRST
Access	R	R		R	R	R	R	R
Reset	0	0		0	0	0	0	0

**Bits 6, 7 – CCx** Compare/Capture Channel x Synchronization Busy

For details on CC channels number, refer to each TC feature list.

This bit is set when the synchronization of CCx between clock domains is started.

This bit is also set when the CCBUFx is written, and cleared on update condition. The bit is automatically cleared when the STATUS.CCBUFx bit is cleared.

**Bit 4 – COUNT** COUNT Synchronization Busy

This bit is cleared when the synchronization of COUNT between the clock domains is complete.

This bit is set when the synchronization of COUNT between clock domains is started.

**Bit 3 – STATUS** STATUS Synchronization Busy

This bit is cleared when the synchronization of STATUS between the clock domains is complete.

This bit is set when a '1' is written to the Capture Channel Buffer Valid status flags (STATUS.CCBUFVx) and the synchronization of STATUS between clock domains is started.

**Bit 2 – CTRLB** CTRLB Synchronization Busy

This bit is cleared when the synchronization of CTRLB between the clock domains is complete.

This bit is set when the synchronization of CTRLB between clock domains is started.

**Bit 1 – ENABLE** ENABLE Synchronization Busy

This bit is cleared when the synchronization of ENABLE bit between the clock domains is complete.

This bit is set when the synchronization of ENABLE bit between clock domains is started.

**Bit 0 – SWRST** SWRST Synchronization Busy

This bit is cleared when the synchronization of SWRST bit between the clock domains is complete.

This bit is set when the synchronization of SWRST bit between clock domains is started.

### 48.7.1.13 Counter Value, 8-bit Mode

**Name:** COUNT  
**Offset:** 0x14  
**Reset:** 0x00  
**Property:** PAC Write-Protection, Write-Synchronized, Read-Synchronized

**Note:** Prior to any read access, this register must be synchronized by user by writing the according TC Command value to the Control B Set register (CTRLBSET.CMD=READSYNC).

	7	6	5	4	3	2	1	0
	COUNT[7:0]							
Access	R/W	R/W	R/W	R/W	R/W	R/W	R/W	R/W
Reset	0	0	0	0	0	0	0	0

**Bits 7:0 – COUNT[7:0]** Counter Value  
 These bits contain the current counter value.

### 48.7.1.14 Period Value, 8-bit Mode

**Name:** PER  
**Offset:** 0x1B  
**Reset:** 0xFF  
**Property:** Write-Synchronized

Bit	7	6	5	4	3	2	1	0
	PER[7:0]							
Access	R/W	R/W	R/W	R/W	R/W	R/W	R/W	R/W
Reset	0	0	0	0	0	0	0	1

**Bits 7:0 – PER[7:0] Period Value**

These bits hold the value of the Period Buffer register PERBUF. The value is copied to PER register on UPDATE condition.

### 48.7.1.15 Channel x Compare/Capture Value, 8-bit Mode

**Name:** CCx  
**Offset:** 0x1C + x\*0x01 [x=0..1]  
**Reset:** 0x00  
**Property:** Write-Synchronized, Read-Synchronized

Bit	7	6	5	4	3	2	1	0
	CC[7:0]							
Access	R/W	R/W	R/W	R/W	R/W	R/W	R/W	R/W
Reset	0	0	0	0	0	0	0	0

**Bits 7:0 – CC[7:0]** Channel x Compare/Capture Value

These bits contain the compare/capture value in 8-bit TC mode. In Match frequency (MFRQ) or Match PWM (MPWM) waveform operation (WAVE.WAVEGEN), the CC0 register is used as a period register.

### 48.7.1.16 Period Buffer Value, 8-bit Mode

**Name:** PERBUF  
**Offset:** 0x2F  
**Reset:** 0xFF  
**Property:** Write-Synchronized

Bit	7	6	5	4	3	2	1	0
	PERBUF[7:0]							
Access	R/W	R/W	R/W	R/W	R/W	R/W	R/W	R/W
Reset	0	0	0	0	0	0	0	1

**Bits 7:0 – PERBUF[7:0]** Period Buffer Value

These bits hold the value of the period buffer register. The value is copied to PER register on UPDATE condition.



### 48.7.1.17 Channel x Compare Buffer Value, 8-bit Mode

**Name:** CCBUFx  
**Offset:** 0x30 + x\*0x01 [x=0..1]  
**Reset:** 0x00  
**Property:** Write-Synchronized

Bit	7	6	5	4	3	2	1	0
	CCBUF[7:0]							
Access	R/W	R/W	R/W	R/W	R/W	R/W	R/W	R/W
Reset	0	0	0	0	0	0	0	0

**Bits 7:0 – CCBUF[7:0]** Channel x Compare Buffer Value

These bits hold the value of the Channel x Compare Buffer Value. When the buffer valid flag is '1' and double buffering is enabled (CTRLBCLR.LUPD=1), the data from buffer registers will be copied into the corresponding CCx register under UPDATE condition (CTRLBSET.CMD=0x3), including the software update command.

# SAM D5x/E5x Family Data Sheet

## TC – Timer/Counter

### 48.7.2 Register Summary - 16-bit Mode

Offset	Name	Bit Pos.									
0x00	CTRLA	7:0	ONDEMAND	RUNSTDBY	PRESCSYNC[1:0]		MODE[1:0]		ENABLE	SWRST	
		15:8	DMAOS				ALOCK	PRESCALER[2:0]			
		23:16			COPEN1	COPEN0			CAPTEN1	CAPTEN0	
		31:24				CAPTMODE1[1:0]			CAPTMODE0[1:0]		
0x04	CTRLBCLR	7:0	CMD[2:0]				ONESHOT	LUPD	DIR		
0x05	CTRLBSET	7:0	CMD[2:0]				ONESHOT	LUPD	DIR		
0x06	EVCTRL	7:0			TCEI	TCINV		EVACT[2:0]			
		15:8			MCEO1	MCEO0			OVFEO		
0x08	INTENCLR	7:0			MC1	MC0		ERR	OVF		
0x09	INTENSET	7:0			MC1	MC0		ERR	OVF		
0x0A	INTFLAG	7:0			MC1	MC0		ERR	OVF		
0x0B	STATUS	7:0			CCBUFV1	CCBUFV0	PERBUFV		SLAVE	STOP	
0x0C	WAVE	7:0						WAVEGEN[1:0]			
0x0D	DRVCTRL	7:0						INVEN1	INVEN0		
0x0E	Reserved										
0x0F	DBGCTRL	7:0							DBGRUN		
0x10	SYNCBUSY	7:0	CC1	CC0		COUNT	STATUS	CTRLB	ENABLE	SWRST	
		15:8									
		23:16									
		31:24									
0x14	COUNT	7:0	COUNT[7:0]								
		15:8	COUNT[15:8]								
0x16 ... 0x1B	Reserved										
0x1C	CC0	7:0	CC[7:0]								
		15:8	CC[15:8]								
0x1E	CC1	7:0	CC[7:0]								
		15:8	CC[15:8]								
0x20 ... 0x2F	Reserved										
0x30	CCBUF0	7:0	CCBUF[7:0]								
		15:8	CCBUF[15:8]								
0x32	CCBUF1	7:0	CCBUF[7:0]								
		15:8	CCBUF[15:8]								

# SAM D5x/E5x Family Data Sheet

## TC – Timer/Counter

### 48.7.2.1 Control A

**Name:** CTRLA  
**Offset:** 0x00  
**Reset:** 0x00000000  
**Property:** PAC Write-Protection, Write-Synchronized, Enable-Protected

Bit	31	30	29	28	27	26	25	24
				CAPTMODE1[1:0]				
Access				R/W	R/W			R/W
Reset				0	0			0
Bit	23	22	21	20	19	18	17	16
			COPEN1	COPEN0			CAPTEN1	CAPTEN0
Access			R/W	R/W			R/W	R/W
Reset			0	0			0	0
Bit	15	14	13	12	11	10	9	8
	DMAOS					ALOCK	PRESCALER[2:0]	
Access	R/W					R/W	R/W	R/W
Reset	0					0	0	0
Bit	7	6	5	4	3	2	1	0
	ONDEMAND	RUNSTDBY	PRESCSYNC[1:0]		MODE[1:0]		ENABLE	SWRST
Access	R/W	R/W	R/W	R/W	R/W	R/W	R/W	W
Reset	0	0	0	0	0	0	0	0

#### Bits 28:27 – CAPTMODE1[1:0] Capture mode Channel 1

These bits select the channel 1 capture mode.

Value	Name	Description
0x0	DEFAULT	Default capture
0x1	CAPTMIN	Minimum capture
0x2	CAPTMAX	Maximum capture
0x3		Reserved

#### Bits 25:24 – CAPTMODE0[1:0] Capture mode Channel 0

These bits select the channel 0 capture mode.

Value	Name	Description
0x0	DEFAULT	Default capture
0x1	CAPTMIN	Minimum capture
0x2	CAPTMAX	Maximum capture
0x3		Reserved

#### Bits 20, 21 – COPENx Capture On Pin x Enable

Bit x of COPEN[1:0] selects the trigger source for capture operation, either events or I/O pin input.

Value	Description
0	Event from Event System is selected as trigger source for capture operation on channel x.
1	I/O pin is selected as trigger source for capture operation on channel x.

**Bits 16, 17 – CAPTEN<sub>x</sub>** Capture Channel x Enable

Bit x of CAPTEN[1:0] selects whether channel x is a capture or a compare channel.

These bits are not synchronized.

Value	Description
0	CAPTEN disables capture on channel x.
1	CAPTEN enables capture on channel x.

**Bit 15 – DMAOS** DMA One-Shot Trigger Mode

This bit enables the DMA One-shot Trigger Mode.

Writing a '1' to this bit will generate a DMA trigger on TC cycle following a TC\_CTRLBSET\_CMD\_DMAOS command.

Writing a '0' to this bit will generate DMA triggers on each TC cycle.

This bit is not synchronized.

**Bit 11 – ALOCK** Auto Lock

When this bit is set, Lock bit update (LUPD) is set to '1' on each overflow/underflow or re-trigger event.

This bit is not synchronized.

Value	Description
0	The LUPD bit is not affected on overflow/underflow, and re-trigger event.
1	The LUPD bit is set on each overflow/underflow or re-trigger event.

**Bits 10:8 – PRESCALER[2:0]** Prescaler

These bits select the counter prescaler factor.

These bits are not synchronized.

Value	Name	Description
0x0	DIV1	Prescaler: GCLK_TC
0x1	DIV2	Prescaler: GCLK_TC/2
0x2	DIV4	Prescaler: GCLK_TC/4
0x3	DIV8	Prescaler: GCLK_TC/8
0x4	DIV16	Prescaler: GCLK_TC/16
0x5	DIV64	Prescaler: GCLK_TC/64
0x6	DIV256	Prescaler: GCLK_TC/256
0x7	DIV1024	Prescaler: GCLK_TC/1024

**Bit 7 – ONDEMAND** Clock On Demand

This bit selects the clock requirements when the TC is stopped.

In standby mode, if the Run in Standby bit (CTRLA.RUNSTDBY) is '0', ONDEMAND is forced to '0'.

This bit is not synchronized.

Value	Description
0	The On Demand is disabled. If On Demand is disabled, the TC will continue to request the clock when its operation is stopped (STATUS.STOP=1).
1	The On Demand is enabled. When On Demand is enabled, the stopped TC will not request the clock. The clock is requested when a software re-trigger command is applied or when an event with start/re-trigger action is detected.

**Bit 6 – RUNSTDBY** Run in Standby

This bit is used to keep the TC running in standby mode.

This bit is not synchronized.

Value	Description
0	The TC is halted in standby.
1	The TC continues to run in standby.

### Bits 5:4 – PRESCSYNC[1:0] Prescaler and Counter Synchronization

These bits select whether the counter should wrap around on the next GCLK\_TCx clock or the next prescaled GCLK\_TCx clock. It also makes it possible to reset the prescaler.

These bits are not synchronized.

Value	Name	Description
0x0	GCLK	Reload or reset the counter on next generic clock
0x1	PRESC	Reload or reset the counter on next prescaler clock
0x2	RESYNC	Reload or reset the counter on next generic clock. Reset the prescaler counter
0x3	-	Reserved

### Bits 3:2 – MODE[1:0] Timer Counter Mode

These bits select the counter mode.

These bits are not synchronized.

Value	Name	Description
0x0	COUNT16	Counter in 16-bit mode
0x1	COUNT8	Counter in 8-bit mode
0x2	COUNT32	Counter in 32-bit mode
0x3	-	Reserved

### Bit 1 – ENABLE Enable

Due to synchronization, there is delay from writing CTRLA.ENABLE until the peripheral is enabled/disabled. The value written to CTRLA.ENABLE will read back immediately, and the ENABLE Synchronization Busy bit in the SYNCBUSY register (SYNCBUSY.ENABLE) will be set.

SYNCBUSY.ENABLE will be cleared when the operation is complete.

This bit is not enable protected.

Value	Description
0	The peripheral is disabled.
1	The peripheral is enabled.

### Bit 0 – SWRST Software Reset

Writing a '0' to this bit has no effect.

Writing a '1' to this bit resets all registers in the TC, except DBGCTRL, to their initial state, and the TC will be disabled.

Writing a '1' to CTRLA.SWRST will always take precedence; all other writes in the same write-operation will be discarded.

### 48.7.2.2 Control B Clear

**Name:** CTRLBCLR  
**Offset:** 0x04  
**Reset:** 0x00  
**Property:** PAC Write-Protection, Read-Synchronized, Write-Synchronized

This register allows the user to clear bits in the CTRLB register without doing a read-modify-write operation. Changes in this register will also be reflected in the Control B Set register (CTRLBSET).

Bit	7	6	5	4	3	2	1	0
	CMD[2:0]					ONESHOT	LUPD	DIR
Access	R/W	R/W	R/W			R/W	R/W	R/W
Reset	0	0	0			0	0	0

#### Bits 7:5 – CMD[2:0] Command

These bits are used for software control of the TC. The commands are executed on the next prescaled GCLK\_TC clock cycle. When a command has been executed, the CMD bit group will be read back as zero.

Writing 0x0 to these bits has no effect.

Writing a '1' to any of these bits will clear the pending command.

#### Bit 2 – ONESHOT One-Shot on Counter

This bit controls one-shot operation of the TC.

Writing a '0' to this bit has no effect

Writing a '1' to this bit will disable one-shot operation.

Value	Description
0	The TC will wrap around and continue counting on an overflow/underflow condition.
1	The TC will wrap around and stop on the next underflow/overflow condition.

#### Bit 1 – LUPD Lock Update

This bit controls the update operation of the TC buffered registers.

When CTRLB.LUPD is set, no any update of the registers with value of its buffered register is performed on hardware UPDATE condition. Locking the update ensures that all buffer registers are valid before an hardware update is performed. After all the buffer registers are loaded correctly, the buffered registers can be unlocked.

This bit has no effect when input capture operation is enabled.

Writing a '0' to this bit has no effect.

Writing a '1' to this bit will clear the LUPD bit.

Value	Description
0	The CCBUFx and PERBUF buffer registers value are copied into CCx and PER registers on hardware update condition.
1	The CCBUFx and PERBUF buffer registers value are not copied into CCx and PER registers on hardware update condition.

#### Bit 0 – DIR Counter Direction

This bit is used to change the direction of the counter.

Writing a '0' to this bit has no effect.

Writing a '1' to this bit will clear the bit and make the counter count up.

# SAM D5x/E5x Family Data Sheet

## TC – Timer/Counter

---

---

Value	Description
0	The timer/counter is counting up (incrementing).
1	The timer/counter is counting down (decrementing).

### 48.7.2.3 Control B Set

**Name:** CTRLBSET  
**Offset:** 0x05  
**Reset:** 0x00  
**Property:** PAC Write-Protection, Read-synchronized, Write-Synchronized

This register allows the user to set bits in the CTRLB register without doing a read-modify-write operation. Changes in this register will also be reflected in the Control B Clear register (CTRLBCLR).

	7	6	5	4	3	2	1	0
	CMD[2:0]					ONESHOT	LUPD	DIR
Access	R/W	R/W	R/W			R/W	R/W	R/W
Reset	0	0	0			0	0	0

#### Bits 7:5 – CMD[2:0] Command

These bits are used for software control of the TC. The commands are executed on the next prescaled GCLK\_TC clock cycle. When a command has been executed, the CMD bit group will be read back as zero.

Writing 0x0 to these bits has no effect.

Writing a value different from 0x0 to these bits will issue a command for execution.

Value	Name	Description
0x0	NONE	No action
0x1	RETRIGGER	Force a start, restart or retrigger
0x2	STOP	Force a stop
0x3	UPDATE	Force update of double buffered registers
0x4	READSYNC	Force a read synchronization of COUNT

#### Bit 2 – ONESHOT One-Shot on Counter

This bit controls one-shot operation of the TC.

Writing a '0' to this bit has no effect.

Writing a '1' to this bit will enable one-shot operation.

Value	Description
0	The TC will wrap around and continue counting on an overflow/underflow condition.
1	The TC will wrap around and stop on the next underflow/overflow condition.

#### Bit 1 – LUPD Lock Update

This bit controls the update operation of the TC buffered registers.

When CTRLB.LUPD is set, no any update of the registers with value of its buffered register is performed on hardware UPDATE condition. Locking the update ensures that all buffer registers are valid before an hardware update is performed. After all the buffer registers are loaded correctly, the buffered registers can be unlocked.

Writing a '0' to this bit has no effect.

Writing a '1' to this bit will set the LUPD bit.

This bit has no effect when input capture operation is enabled.

Value	Description
0	The CCBUFx and PERBUF buffer registers value are copied into CCx and PER registers on hardware update condition.



---

---

Value	Description
1	The CCBUFx and PERBUF buffer registers value are not copied into CCx and PER registers on hardware update condition.

### Bit 0 – DIR Counter Direction

This bit is used to change the direction of the counter.

Writing a '0' to this bit has no effect

Writing a '1' to this bit will clear the bit and make the counter count up.

Value	Description
0	The timer/counter is counting up (incrementing).
1	The timer/counter is counting down (decrementing).

### 48.7.2.4 Event Control

**Name:** EVCTRL  
**Offset:** 0x06  
**Reset:** 0x0000  
**Property:** PAC Write-Protection, Enable-Protected

	Bit	15	14	13	12	11	10	9	8
				MCEO1	MCEO0				OVFEO
Access				R/W	R/W				R/W
Reset				0	0				0
	Bit	7	6	5	4	3	2	1	0
				TCEI	TCINV		EVACT[2:0]		
Access				R/W	R/W		R/W	R/W	R/W
Reset				0	0		0	0	0

#### Bit 13 – MCEO1 Match or Capture Channel x Event Output Enable [x = 1..0]

These bits enable the generation of an event for every match or capture on channel x.

Value	Description
0	Match/Capture event on channel x is disabled and will not be generated.
1	Match/Capture event on channel x is enabled and will be generated for every compare/capture.

#### Bit 12 – MCEO0 Match or Capture Channel x Event Output Enable [x = 1..0]

These bits enable the generation of an event for every match or capture on channel x.

Value	Description
0	Match/Capture event on channel x is disabled and will not be generated.
1	Match/Capture event on channel x is enabled and will be generated for every compare/capture.

#### Bit 8 – OVFEO Overflow/Underflow Event Output Enable

This bit enables the Overflow/Underflow event. When enabled, an event will be generated when the counter overflows/underflows.

Value	Description
0	Overflow/Underflow event is disabled and will not be generated.
1	Overflow/Underflow event is enabled and will be generated for every counter overflow/underflow.

#### Bit 5 – TCEI TC Event Enable

This bit is used to enable asynchronous input events to the TC.

Value	Description
0	Incoming events are disabled.
1	Incoming events are enabled.

#### Bit 4 – TCINV TC Inverted Event Input Polarity

This bit inverts the asynchronous input event source.

Value	Description
0	Input event source is not inverted.

Value	Description
1	Input event source is inverted.

### Bits 2:0 – EVACT[2:0] Event Action

These bits define the event action the TC will perform on an event.

Value	Name	Description
0x0	OFF	Event action disabled
0x1	RETRIGGER	Start, restart or retrigger TC on event
0x2	COUNT	Count on event
0x3	START	Start TC on event
0x4	STAMP	Time stamp capture
0x5	PPW	Period captured in CC0, pulse width in CC1
0x6	PWP	Period captured in CC1, pulse width in CC0
0x7	PW	Pulse width capture

### 48.7.2.5 Interrupt Enable Clear

**Name:** INTENCLR  
**Offset:** 0x08  
**Reset:** 0x00  
**Property:** PAC Write-Protection

This register allows the user to disable an interrupt without doing a read-modify-write operation. Changes in this register will also be reflected in the Interrupt Enable Set register (INTENSET).

	7	6	5	4	3	2	1	0
			MC1	MC0			ERR	OVF
Access			R/W	R/W			R/W	R/W
Reset			0	0			0	0

#### Bit 5 – MC1 Match or Capture Channel x Interrupt Enable

Writing a '0' to these bits has no effect.

Writing a '1' to MCx will clear the corresponding Match or Capture Channel x Interrupt Enable bit, which disables the Match or Capture Channel x interrupt.

Value	Description
0	The Match or Capture Channel x interrupt is disabled.
1	The Match or Capture Channel x interrupt is enabled.

#### Bit 4 – MC0 Match or Capture Channel x Interrupt Enable

Writing a '0' to these bits has no effect.

Writing a '1' to MCx will clear the corresponding Match or Capture Channel x Interrupt Enable bit, which disables the Match or Capture Channel x interrupt.

Value	Description
0	The Match or Capture Channel x interrupt is disabled.
1	The Match or Capture Channel x interrupt is enabled.

#### Bit 1 – ERR Error Interrupt Disable

Writing a '0' to this bit has no effect.

Writing a '1' to this bit will clear the Error Interrupt Enable bit, which disables the Error interrupt.

Value	Description
0	The Error interrupt is disabled.
1	The Error interrupt is enabled.

#### Bit 0 – OVF Overflow Interrupt Disable

Writing a '0' to this bit has no effect.

Writing a '1' to this bit will clear the Overflow Interrupt Enable bit, which disables the Overflow interrupt request.

Value	Description
0	The Overflow interrupt is disabled.
1	The Overflow interrupt is enabled.

### 48.7.2.6 Interrupt Enable Set

**Name:** INTENSET  
**Offset:** 0x09  
**Reset:** 0x00  
**Property:** PAC Write-Protection

This register allows the user to enable an interrupt without doing a read-modify-write operation. Changes in this register will also be reflected in the Interrupt Enable Clear register (INTENCLR).

	7	6	5	4	3	2	1	0
			MC1	MC0			ERR	OVF
Access			R/W	R/W			R/W	R/W
Reset			0	0			0	0

#### Bit 5 – MC1 Match or Capture Channel x Interrupt Enable

Writing a '0' to these bits has no effect.

Writing a '1' to MCx will set the corresponding Match or Capture Channel x Interrupt Enable bit, which enables the Match or Capture Channel x interrupt.

Value	Description
0	The Match or Capture Channel x interrupt is disabled.
1	The Match or Capture Channel x interrupt is enabled.

#### Bit 4 – MC0 Match or Capture Channel x Interrupt Enable

Writing a '0' to these bits has no effect.

Writing a '1' to MCx will set the corresponding Match or Capture Channel x Interrupt Enable bit, which enables the Match or Capture Channel x interrupt.

Value	Description
0	The Match or Capture Channel x interrupt is disabled.
1	The Match or Capture Channel x interrupt is enabled.

#### Bit 1 – ERR Error Interrupt Enable

Writing a '0' to this bit has no effect.

Writing a '1' to this bit will set the Error Interrupt Enable bit, which enables the Error interrupt.

Value	Description
0	The Error interrupt is disabled.
1	The Error interrupt is enabled.

#### Bit 0 – OVF Overflow Interrupt Enable

Writing a '0' to this bit has no effect.

Writing a '1' to this bit will set the Overflow Interrupt Enable bit, which enables the Overflow interrupt request.

Value	Description
0	The Overflow interrupt is disabled.
1	The Overflow interrupt is enabled.

### 48.7.2.7 Interrupt Flag Status and Clear

**Name:** INTFLAG  
**Offset:** 0x0A  
**Reset:** 0x00  
**Property:** -

	7	6	5	4	3	2	1	0
Access			R/W	R/W			R/W	R/W
Reset			0	0			0	0

#### Bit 5 – MC1 Match or Capture Channel x

This flag is set on a comparison match, or when the corresponding CCx register contains a valid capture value. This flag is set on the next CLK\_TC\_CNT cycle, and will generate an interrupt request if the corresponding Match or Capture Channel x Interrupt Enable bit in the Interrupt Enable Set register (INTENSET.MCx) is '1'.

Writing a '0' to one of these bits has no effect.

Writing a '1' to one of these bits will clear the corresponding Match or Capture Channel x interrupt flag. In capture operation, this flag is automatically cleared when CCx register is read.

#### Bit 4 – MC0 Match or Capture Channel x

This flag is set on a comparison match, or when the corresponding CCx register contains a valid capture value. This flag is set on the next CLK\_TC\_CNT cycle, and will generate an interrupt request if the corresponding Match or Capture Channel x Interrupt Enable bit in the Interrupt Enable Set register (INTENSET.MCx) is '1'.

Writing a '0' to one of these bits has no effect.

Writing a '1' to one of these bits will clear the corresponding Match or Capture Channel x interrupt flag. In capture operation, this flag is automatically cleared when CCx register is read.

#### Bit 1 – ERR Error Interrupt Flag

This flag is set when a new capture occurs on a channel while the corresponding Match or Capture Channel x interrupt flag is set, in which case there is nowhere to store the new capture.

Writing a '0' to this bit has no effect.

Writing a '1' to this bit clears the Error interrupt flag.

#### Bit 0 – OVF Overflow Interrupt Flag

This flag is set on the next CLK\_TC\_CNT cycle after an overflow condition occurs, and will generate an interrupt request if INTENCLR.OVF or INTENSET.OVF is '1'.

Writing a '0' to this bit has no effect.

Writing a '1' to this bit clears the Overflow interrupt flag.

### 48.7.2.8 Status

**Name:** STATUS  
**Offset:** 0x0B  
**Reset:** 0x01  
**Property:** Read-Synchronized

	7	6	5	4	3	2	1	0
			CCBUFV1	CCBUFV0	PERBUFV		SLAVE	STOP
Access			R/W	R/W	R/W		R	R
Reset			0	0	0		0	1

**Bits 4, 5 – CCBUFV** Channel x Compare or Capture Buffer Valid

For a compare channel x, the bit x is set when a new value is written to the corresponding CCBUFx register.

The bit x is cleared by writing a '1' to it when CTRLB.LUPD is set, or it is cleared automatically by hardware on UPDATE condition.

For a capture channel x, the bit x is set when a valid capture value is stored in the CCBUFx register. The bit x is cleared automatically when the CCx register is read.

**Bit 3 – PERBUFV** Period Buffer Valid

This bit is set when a new value is written to the PERBUF register. The bit is cleared by writing '1' to the corresponding location when CTRLB.LUPD is set, or automatically cleared by hardware on UPDATE condition. This bit is available only in 8-bit mode and will always read zero in 16- and 32-bit modes.

**Bit 1 – SLAVE** Slave Status Flag

This bit is only available in 32-bit mode on the slave TC (i.e., TC1 and/or TC3). The bit is set when the associated master TC (TC0 and TC2, respectively) is set to run in 32-bit mode.

**Bit 0 – STOP** Stop Status Flag

This bit is set when the TC is disabled, on a Stop command, or on an overflow/underflow condition when the One-Shot bit in the Control B Set register (CTRLBSET.ONESHOT) is '1'.

Value	Description
0	Counter is running.
1	Counter is stopped.

# SAM D5x/E5x Family Data Sheet

## TC – Timer/Counter

### 48.7.2.9 Waveform Generation Control

**Name:** WAVE  
**Offset:** 0x0C  
**Reset:** 0x00  
**Property:** PAC Write-Protection, Enable-Protected

Bit	7	6	5	4	3	2	1	0
							WAVEGEN[1:0]	
Access							R/W	R/W
Reset							0	0

#### Bits 1:0 – WAVEGEN[1:0] Waveform Generation Mode

These bits select the waveform generation operation. They affect the top value, as shown in [48.6.2.6.1 Waveform Output Operations](#). They also control whether frequency or PWM waveform generation should be used. The waveform generation operations are explained in [48.6.2.6.1 Waveform Output Operations](#). These bits are not synchronized.

Value	Name	Operation	Top Value	Output Waveform on Match	Output Waveform on Wraparound
0x0	NFRQ	Normal frequency	PER <sup>1</sup> / Max	Toggle	No action
0x1	MFRQ	Match frequency	CC0	Toggle	No action
0x2	NPWM	Normal PWM	PER <sup>1</sup> / Max	Set	Clear
0x3	MPWM	Match PWM	CC0	Set	Clear

1) This depends on the TC mode: In 8-bit mode, the top value is the Period Value register (PER). In 16- and 32-bit mode it is the respective MAX value.



### 48.7.2.10 Driver Control

**Name:** DRVCTRL  
**Offset:** 0x0D  
**Reset:** 0x00  
**Property:** PAC Write-Protection, Enable-Protected

Bit	7	6	5	4	3	2	1	0
							INVEN1	INVEN0
Access							R/W	R/W
Reset							0	0

**Bits 0, 1 – INVENx** Output Waveform x Invert Enable

Bit x of INVEN[1:0] selects inversion of the output or capture trigger input of channel x.

Value	Description
0	Disable inversion of the WO[x] output and IO input pin.
1	Enable inversion of the WO[x] output and IO input pin.

# SAM D5x/E5x Family Data Sheet

## TC – Timer/Counter

### 48.7.2.11 Debug Control

**Name:** DBGCTRL  
**Offset:** 0x0F  
**Reset:** 0x00  
**Property:** PAC Write-Protection

Bit	7	6	5	4	3	2	1	0
								DBGRUN
Access								R/W
Reset								0

#### Bit 0 – DBGRUN Run in Debug Mode

This bit is not affected by a software Reset, and should not be changed by software while the TC is enabled.

Value	Description
0	The TC is halted when the device is halted in debug mode.
1	The TC continues normal operation when the device is halted in debug mode.

### 48.7.2.12 Synchronization Busy

**Name:** SYNCBUSY  
**Offset:** 0x10  
**Reset:** 0x00000000  
**Property:** -

Bit	31	30	29	28	27	26	25	24
Access								
Reset								
Bit	23	22	21	20	19	18	17	16
Access								
Reset								
Bit	15	14	13	12	11	10	9	8
Access								
Reset								
Bit	7	6	5	4	3	2	1	0
	CC1	CC0		COUNT	STATUS	CTRLB	ENABLE	SWRST
Access	R	R		R	R	R	R	R
Reset	0	0		0	0	0	0	0

**Bits 6, 7 – CCx** Compare/Capture Channel x Synchronization Busy

For details on CC channels number, refer to each TC feature list.

This bit is set when the synchronization of CCx between clock domains is started.

This bit is also set when the CCBUFx is written, and cleared on update condition. The bit is automatically cleared when the STATUS.CCBUFx bit is cleared.

**Bit 4 – COUNT** COUNT Synchronization Busy

This bit is cleared when the synchronization of COUNT between the clock domains is complete.

This bit is set when the synchronization of COUNT between clock domains is started.

**Bit 3 – STATUS** STATUS Synchronization Busy

This bit is cleared when the synchronization of STATUS between the clock domains is complete.

This bit is set when a '1' is written to the Capture Channel Buffer Valid status flags (STATUS.CCBUFVx) and the synchronization of STATUS between clock domains is started.

**Bit 2 – CTRLB** CTRLB Synchronization Busy

This bit is cleared when the synchronization of CTRLB between the clock domains is complete.

This bit is set when the synchronization of CTRLB between clock domains is started.

**Bit 1 – ENABLE** ENABLE Synchronization Busy

This bit is cleared when the synchronization of ENABLE bit between the clock domains is complete.

This bit is set when the synchronization of ENABLE bit between clock domains is started.

**Bit 0 – SWRST** SWRST Synchronization Busy

This bit is cleared when the synchronization of SWRST bit between the clock domains is complete.

This bit is set when the synchronization of SWRST bit between clock domains is started.

### 48.7.2.13 Counter Value, 16-bit Mode

**Name:** COUNT  
**Offset:** 0x14  
**Reset:** 0x00  
**Property:** PAC Write-Protection, Write-Synchronized, Read-Synchronized

**Note:** Prior to any read access, this register must be synchronized by user by writing the according TC Command value to the Control B Set register (CTRLBSET.CMD=READSYNC).

	Bit	15	14	13	12	11	10	9	8
		COUNT[15:8]							
Access		R/W	R/W	R/W	R/W	R/W	R/W	R/W	R/W
Reset		0	0	0	0	0	0	0	0
	Bit	7	6	5	4	3	2	1	0
		COUNT[7:0]							
Access		R/W	R/W	R/W	R/W	R/W	R/W	R/W	R/W
Reset		0	0	0	0	0	0	0	0

**Bits 15:0 – COUNT[15:0]** Counter Value  
 These bits contain the current counter value.

### 48.7.2.14 Channel x Compare/Capture Value, 16-bit Mode

**Name:** CCx  
**Offset:** 0x1C + x\*0x02 [x=0..1]  
**Reset:** 0x0000  
**Property:** Write-Synchronized

	Bit	15	14	13	12	11	10	9	8
		CC[15:8]							
Access		R/W	R/W	R/W	R/W	R/W	R/W	R/W	R/W
Reset		0	0	0	0	0	0	0	0
	Bit	7	6	5	4	3	2	1	0
		CC[7:0]							
Access		R/W	R/W	R/W	R/W	R/W	R/W	R/W	R/W
Reset		0	0	0	0	0	0	0	0

**Bits 15:0 – CC[15:0]** Channel x Compare/Capture Value

These bits contain the compare/capture value in 16-bit TC mode. In Match frequency (MFRQ) or Match PWM (MPWM) waveform operation (WAVE.WAVEGEN), the CC0 register is used as a period register.

### 48.7.2.15 Channel x Compare Buffer Value, 16-bit Mode

**Name:** CCBUFx  
**Offset:** 0x30 + x\*0x02 [x=0..1]  
**Reset:** 0x0000  
**Property:** Write-Synchronized

Bit	15	14	13	12	11	10	9	8
	CCBUF[15:8]							
Access	R/W	R/W	R/W	R/W	R/W	R/W	R/W	R/W
Reset	0	0	0	0	0	0	0	0
Bit	7	6	5	4	3	2	1	0
	CCBUF[7:0]							
Access	R/W	R/W	R/W	R/W	R/W	R/W	R/W	R/W
Reset	0	0	0	0	0	0	0	0

**Bits 15:0 – CCBUF[15:0]** Channel x Compare Buffer Value

These bits hold the value of the Channel x Compare Buffer Value. When the buffer valid flag is '1' and double buffering is enabled (CTRLBCLR.LUPD=1), the data from buffer registers will be copied into the corresponding CCx register under UPDATE condition (CTRLBSET.CMD=0x3), including the software update command.

# SAM D5x/E5x Family Data Sheet

## TC – Timer/Counter

### 48.7.3 Register Summary - 32-bit Mode

Offset	Name	Bit Pos.									
0x00	CTRLA	7:0	ONDEMAND	RUNSTDBY	PRESCSYNC[1:0]		MODE[1:0]		ENABLE	SWRST	
		15:8	DMAOS				ALOCK	PRESCALER[2:0]			
		23:16			COPEN1	COPEN0			CAPTEN1	CAPTEN0	
		31:24				CAPTMODE1[1:0]			CAPTMODE0[1:0]		
0x04	CTRLBCLR	7:0	CMD[2:0]				ONESHOT	LUPD	DIR		
0x05	CTRLBSET	7:0	CMD[2:0]				ONESHOT	LUPD	DIR		
0x06	EVCTRL	7:0			TCEI	TCINV		EVACT[2:0]			
		15:8			MCEO1	MCEO0			OVFEO		
0x08	INTENCLR	7:0			MC1	MC0		ERR	OVF		
0x09	INTENSET	7:0			MC1	MC0		ERR	OVF		
0x0A	INTFLAG	7:0			MC1	MC0		ERR	OVF		
0x0B	STATUS	7:0			CCBUFV1	CCBUFV0	PERBUFV		SLAVE	STOP	
0x0C	WAVE	7:0						WAVEGEN[1:0]			
0x0D	DRVCTRL	7:0						INVEN1	INVEN0		
0x0E	Reserved										
0x0F	DBGCTRL	7:0							DBGRUN		
0x10	SYNCBUSY	7:0	CC1	CC0		COUNT	STATUS	CTRLB	ENABLE	SWRST	
		15:8									
		23:16									
		31:24									
0x14	COUNT	7:0	COUNT[7:0]								
		15:8	COUNT[15:8]								
		23:16	COUNT[23:16]								
		31:24	COUNT[31:24]								
0x18 ... 0x1B	Reserved										
0x1C	CC0	7:0	CC[7:0]								
		15:8	CC[15:8]								
		23:16	CC[23:16]								
		31:24	CC[31:24]								
0x20	CC1	7:0	CC[7:0]								
		15:8	CC[15:8]								
		23:16	CC[23:16]								
		31:24	CC[31:24]								
0x24 ... 0x2F	Reserved										
0x30	CCBUF0	7:0	CCBUF[7:0]								
		15:8	CCBUF[15:8]								
		23:16	CCBUF[23:16]								
		31:24	CCBUF[31:24]								



# SAM D5x/E5x Family Data Sheet

## TC – Timer/Counter

.....continued

Offset	Name	Bit Pos.									
0x34	CCBUF1	7:0	CCBUF[7:0]								
		15:8	CCBUF[15:8]								
		23:16	CCBUF[23:16]								
		31:24	CCBUF[31:24]								

# SAM D5x/E5x Family Data Sheet

## TC – Timer/Counter

### 48.7.3.1 Control A

**Name:** CTRLA  
**Offset:** 0x00  
**Reset:** 0x00000000  
**Property:** PAC Write-Protection, Write-Synchronized, Enable-Protected

Bit	31	30	29	28	27	26	25	24
				CAPTMODE1[1:0]				
Access				R/W	R/W			
Reset				0	0			
Bit	23	22	21	20	19	18	17	16
			COPEN1	COPEN0			CAPTEN1	CAPTEN0
Access			R/W	R/W			R/W	R/W
Reset			0	0			0	0
Bit	15	14	13	12	11	10	9	8
	DMAOS					ALOCK	PRESCALER[2:0]	
Access	R/W					R/W	R/W	R/W
Reset	0					0	0	0
Bit	7	6	5	4	3	2	1	0
	ONDEMAND	RUNSTDBY	PRESCSYNC[1:0]		MODE[1:0]		ENABLE	SWRST
Access	R/W	R/W	R/W	R/W	R/W	R/W	R/W	W
Reset	0	0	0	0	0	0	0	0

#### Bits 28:27 – CAPTMODE1[1:0] Capture mode Channel 1

These bits select the channel 1 capture mode.

Value	Name	Description
0x0	DEFAULT	Default capture
0x1	CAPTMIN	Minimum capture
0x2	CAPTMAX	Maximum capture
0x3		Reserved

#### Bits 25:24 – CAPTMODE0[1:0] Capture mode Channel 0

These bits select the channel 0 capture mode.

Value	Name	Description
0x0	DEFAULT	Default capture
0x1	CAPTMIN	Minimum capture
0x2	CAPTMAX	Maximum capture
0x3		Reserved

#### Bits 20, 21 – COPENx Capture On Pin x Enable

Bit x of COPEN[1:0] selects the trigger source for capture operation, either events or I/O pin input.

Value	Description
0	Event from Event System is selected as trigger source for capture operation on channel x.
1	I/O pin is selected as trigger source for capture operation on channel x.

### Bits 16, 17 – CAPTENx Capture Channel x Enable

Bit x of CAPTEN[1:0] selects whether channel x is a capture or a compare channel.

These bits are not synchronized.

Value	Description
0	CAPTEN disables capture on channel x.
1	CAPTEN enables capture on channel x.

### Bit 15 – DMAOS DMA One-Shot Trigger Mode

This bit enables the DMA One-shot Trigger Mode.

Writing a '1' to this bit will generate a DMA trigger on TC cycle following a TC\_CTRLBSET\_CMD\_DMAOS command.

Writing a '0' to this bit will generate DMA triggers on each TC cycle.

This bit is not synchronized.

### Bit 11 – ALOCK Auto Lock

When this bit is set, Lock bit update (LUPD) is set to '1' on each overflow/underflow or re-trigger event.

This bit is not synchronized.

Value	Description
0	The LUPD bit is not affected on overflow/underflow, and re-trigger event.
1	The LUPD bit is set on each overflow/underflow or re-trigger event.

### Bits 10:8 – PRESCALER[2:0] Prescaler

These bits select the counter prescaler factor.

These bits are not synchronized.

Value	Name	Description
0x0	DIV1	Prescaler: GCLK_TC
0x1	DIV2	Prescaler: GCLK_TC/2
0x2	DIV4	Prescaler: GCLK_TC/4
0x3	DIV8	Prescaler: GCLK_TC/8
0x4	DIV16	Prescaler: GCLK_TC/16
0x5	DIV64	Prescaler: GCLK_TC/64
0x6	DIV256	Prescaler: GCLK_TC/256
0x7	DIV1024	Prescaler: GCLK_TC/1024

### Bit 7 – ONDEMAND Clock On Demand

This bit selects the clock requirements when the TC is stopped.

In standby mode, if the Run in Standby bit (CTRLA.RUNSTDBY) is '0', ONDEMAND is forced to '0'.

This bit is not synchronized.

Value	Description
0	The On Demand is disabled. If On Demand is disabled, the TC will continue to request the clock when its operation is stopped (STATUS.STOP=1).
1	The On Demand is enabled. When On Demand is enabled, the stopped TC will not request the clock. The clock is requested when a software re-trigger command is applied or when an event with start/re-trigger action is detected.

### Bit 6 – RUNSTDBY Run in Standby

This bit is used to keep the TC running in standby mode.

This bit is not synchronized.

Value	Description
0	The TC is halted in standby.
1	The TC continues to run in standby.

### Bits 5:4 – PRESCSYNC[1:0] Prescaler and Counter Synchronization

These bits select whether the counter should wrap around on the next GCLK\_TCx clock or the next prescaled GCLK\_TCx clock. It also makes it possible to reset the prescaler.

These bits are not synchronized.

Value	Name	Description
0x0	GCLK	Reload or reset the counter on next generic clock
0x1	PRESC	Reload or reset the counter on next prescaler clock
0x2	RESYNC	Reload or reset the counter on next generic clock. Reset the prescaler counter
0x3	-	Reserved

### Bits 3:2 – MODE[1:0] Timer Counter Mode

These bits select the counter mode.

These bits are not synchronized.

Value	Name	Description
0x0	COUNT16	Counter in 16-bit mode
0x1	COUNT8	Counter in 8-bit mode
0x2	COUNT32	Counter in 32-bit mode
0x3	-	Reserved

### Bit 1 – ENABLE Enable

Due to synchronization, there is delay from writing CTRLA.ENABLE until the peripheral is enabled/disabled. The value written to CTRLA.ENABLE will read back immediately, and the ENABLE Synchronization Busy bit in the SYNCBUSY register (SYNCBUSY.ENABLE) will be set.

SYNCBUSY.ENABLE will be cleared when the operation is complete.

This bit is not enable protected.

Value	Description
0	The peripheral is disabled.
1	The peripheral is enabled.

### Bit 0 – SWRST Software Reset

Writing a '0' to this bit has no effect.

Writing a '1' to this bit resets all registers in the TC, except DBGCTRL, to their initial state, and the TC will be disabled.

Writing a '1' to CTRLA.SWRST will always take precedence; all other writes in the same write-operation will be discarded.

### 48.7.3.2 Control B Clear

**Name:** CTRLBCLR  
**Offset:** 0x04  
**Reset:** 0x00  
**Property:** PAC Write-Protection, Read-Synchronized, Write-Synchronized

This register allows the user to clear bits in the CTRLB register without doing a read-modify-write operation. Changes in this register will also be reflected in the Control B Set register (CTRLBSET).

Bit	7	6	5	4	3	2	1	0
	CMD[2:0]					ONESHOT	LUPD	DIR
Access	R/W	R/W	R/W			R/W	R/W	R/W
Reset	0	0	0			0	0	0

#### Bits 7:5 – CMD[2:0] Command

These bits are used for software control of the TC. The commands are executed on the next prescaled GCLK\_TC clock cycle. When a command has been executed, the CMD bit group will be read back as zero.

Writing 0x0 to these bits has no effect.

Writing a '1' to any of these bits will clear the pending command.

#### Bit 2 – ONESHOT One-Shot on Counter

This bit controls one-shot operation of the TC.

Writing a '0' to this bit has no effect

Writing a '1' to this bit will disable one-shot operation.

Value	Description
0	The TC will wrap around and continue counting on an overflow/underflow condition.
1	The TC will wrap around and stop on the next underflow/overflow condition.

#### Bit 1 – LUPD Lock Update

This bit controls the update operation of the TC buffered registers.

When CTRLB.LUPD is set, no any update of the registers with value of its buffered register is performed on hardware UPDATE condition. Locking the update ensures that all buffer registers are valid before an hardware update is performed. After all the buffer registers are loaded correctly, the buffered registers can be unlocked.

This bit has no effect when input capture operation is enabled.

Writing a '0' to this bit has no effect.

Writing a '1' to this bit will clear the LUPD bit.

Value	Description
0	The CCBUFx and PERBUF buffer registers value are copied into CCx and PER registers on hardware update condition.
1	The CCBUFx and PERBUF buffer registers value are not copied into CCx and PER registers on hardware update condition.

#### Bit 0 – DIR Counter Direction

This bit is used to change the direction of the counter.

Writing a '0' to this bit has no effect.

Writing a '1' to this bit will clear the bit and make the counter count up.

# SAM D5x/E5x Family Data Sheet

## TC – Timer/Counter

---

---

Value	Description
0	The timer/counter is counting up (incrementing).
1	The timer/counter is counting down (decrementing).

### 48.7.3.3 Control B Set

**Name:** CTRLBSET  
**Offset:** 0x05  
**Reset:** 0x00  
**Property:** PAC Write-Protection, Read-synchronized, Write-Synchronized

This register allows the user to set bits in the CTRLB register without doing a read-modify-write operation. Changes in this register will also be reflected in the Control B Clear register (CTRLBCLR).

	7	6	5	4	3	2	1	0
	CMD[2:0]					ONESHOT	LUPD	DIR
Access	R/W	R/W	R/W			R/W	R/W	R/W
Reset	0	0	0			0	0	0

#### Bits 7:5 – CMD[2:0] Command

These bits are used for software control of the TC. The commands are executed on the next prescaled GCLK\_TC clock cycle. When a command has been executed, the CMD bit group will be read back as zero.

Writing 0x0 to these bits has no effect.

Writing a value different from 0x0 to these bits will issue a command for execution.

Value	Name	Description
0x0	NONE	No action
0x1	RETRIGGER	Force a start, restart or retrigger
0x2	STOP	Force a stop
0x3	UPDATE	Force update of double buffered registers
0x4	READSYNC	Force a read synchronization of COUNT

#### Bit 2 – ONESHOT One-Shot on Counter

This bit controls one-shot operation of the TC.

Writing a '0' to this bit has no effect.

Writing a '1' to this bit will enable one-shot operation.

Value	Description
0	The TC will wrap around and continue counting on an overflow/underflow condition.
1	The TC will wrap around and stop on the next underflow/overflow condition.

#### Bit 1 – LUPD Lock Update

This bit controls the update operation of the TC buffered registers.

When CTRLB.LUPD is set, no any update of the registers with value of its buffered register is performed on hardware UPDATE condition. Locking the update ensures that all buffer registers are valid before an hardware update is performed. After all the buffer registers are loaded correctly, the buffered registers can be unlocked.

Writing a '0' to this bit has no effect.

Writing a '1' to this bit will set the LUPD bit.

This bit has no effect when input capture operation is enabled.

Value	Description
0	The CCBUFx and PERBUF buffer registers value are copied into CCx and PER registers on hardware update condition.

---

---

Value	Description
1	The CCBUFx and PERBUF buffer registers value are not copied into CCx and PER registers on hardware update condition.

### Bit 0 – DIR Counter Direction

This bit is used to change the direction of the counter.

Writing a '0' to this bit has no effect

Writing a '1' to this bit will clear the bit and make the counter count up.

Value	Description
0	The timer/counter is counting up (incrementing).
1	The timer/counter is counting down (decrementing).



### 48.7.3.4 Event Control

**Name:** EVCTRL  
**Offset:** 0x06  
**Reset:** 0x0000  
**Property:** PAC Write-Protection, Enable-Protected

	Bit	15	14	13	12	11	10	9	8
				MCEO1	MCEO0				OVFEO
Access				R/W	R/W				R/W
Reset				0	0				0
	Bit	7	6	5	4	3	2	1	0
				TCEI	TCINV		EVACT[2:0]		
Access				R/W	R/W		R/W	R/W	R/W
Reset				0	0		0	0	0

**Bit 13 – MCEO1** Match or Capture Channel x Event Output Enable [x = 1..0]

These bits enable the generation of an event for every match or capture on channel x.

Value	Description
0	Match/Capture event on channel x is disabled and will not be generated.
1	Match/Capture event on channel x is enabled and will be generated for every compare/capture.

**Bit 12 – MCEO0** Match or Capture Channel x Event Output Enable [x = 1..0]

These bits enable the generation of an event for every match or capture on channel x.

Value	Description
0	Match/Capture event on channel x is disabled and will not be generated.
1	Match/Capture event on channel x is enabled and will be generated for every compare/capture.

**Bit 8 – OVFEO** Overflow/Underflow Event Output Enable

This bit enables the Overflow/Underflow event. When enabled, an event will be generated when the counter overflows/underflows.

Value	Description
0	Overflow/Underflow event is disabled and will not be generated.
1	Overflow/Underflow event is enabled and will be generated for every counter overflow/underflow.

**Bit 5 – TCEI** TC Event Enable

This bit is used to enable asynchronous input events to the TC.

Value	Description
0	Incoming events are disabled.
1	Incoming events are enabled.

**Bit 4 – TCINV** TC Inverted Event Input Polarity

This bit inverts the asynchronous input event source.

Value	Description
0	Input event source is not inverted.

Value	Description
1	Input event source is inverted.

### Bits 2:0 – EVACT[2:0] Event Action

These bits define the event action the TC will perform on an event.

Value	Name	Description
0x0	OFF	Event action disabled
0x1	RETRIGGER	Start, restart or retrigger TC on event
0x2	COUNT	Count on event
0x3	START	Start TC on event
0x4	STAMP	Time stamp capture
0x5	PPW	Period captured in CC0, pulse width in CC1
0x6	PWP	Period captured in CC1, pulse width in CC0
0x7	PW	Pulse width capture

### 48.7.3.5 Interrupt Enable Clear

**Name:** INTENCLR  
**Offset:** 0x08  
**Reset:** 0x00  
**Property:** PAC Write-Protection

This register allows the user to disable an interrupt without doing a read-modify-write operation. Changes in this register will also be reflected in the Interrupt Enable Set register (INTENSET).

	7	6	5	4	3	2	1	0
			MC1	MC0			ERR	OVF
Access			R/W	R/W			R/W	R/W
Reset			0	0			0	0

#### Bit 5 – MC1 Match or Capture Channel x Interrupt Enable

Writing a '0' to these bits has no effect.

Writing a '1' to MCx will clear the corresponding Match or Capture Channel x Interrupt Enable bit, which disables the Match or Capture Channel x interrupt.

Value	Description
0	The Match or Capture Channel x interrupt is disabled.
1	The Match or Capture Channel x interrupt is enabled.

#### Bit 4 – MC0 Match or Capture Channel x Interrupt Enable

Writing a '0' to these bits has no effect.

Writing a '1' to MCx will clear the corresponding Match or Capture Channel x Interrupt Enable bit, which disables the Match or Capture Channel x interrupt.

Value	Description
0	The Match or Capture Channel x interrupt is disabled.
1	The Match or Capture Channel x interrupt is enabled.

#### Bit 1 – ERR Error Interrupt Disable

Writing a '0' to this bit has no effect.

Writing a '1' to this bit will clear the Error Interrupt Enable bit, which disables the Error interrupt.

Value	Description
0	The Error interrupt is disabled.
1	The Error interrupt is enabled.

#### Bit 0 – OVF Overflow Interrupt Disable

Writing a '0' to this bit has no effect.

Writing a '1' to this bit will clear the Overflow Interrupt Enable bit, which disables the Overflow interrupt request.

Value	Description
0	The Overflow interrupt is disabled.
1	The Overflow interrupt is enabled.

### 48.7.3.6 Interrupt Enable Set

**Name:** INTENSET  
**Offset:** 0x09  
**Reset:** 0x00  
**Property:** PAC Write-Protection

This register allows the user to enable an interrupt without doing a read-modify-write operation. Changes in this register will also be reflected in the Interrupt Enable Clear register (INTENCLR).

	7	6	5	4	3	2	1	0
			MC1	MC0			ERR	OVF
Access			R/W	R/W			R/W	R/W
Reset			0	0			0	0

#### Bit 5 – MC1 Match or Capture Channel x Interrupt Enable

Writing a '0' to these bits has no effect.

Writing a '1' to MCx will set the corresponding Match or Capture Channel x Interrupt Enable bit, which enables the Match or Capture Channel x interrupt.

Value	Description
0	The Match or Capture Channel x interrupt is disabled.
1	The Match or Capture Channel x interrupt is enabled.

#### Bit 4 – MC0 Match or Capture Channel x Interrupt Enable

Writing a '0' to these bits has no effect.

Writing a '1' to MCx will set the corresponding Match or Capture Channel x Interrupt Enable bit, which enables the Match or Capture Channel x interrupt.

Value	Description
0	The Match or Capture Channel x interrupt is disabled.
1	The Match or Capture Channel x interrupt is enabled.

#### Bit 1 – ERR Error Interrupt Enable

Writing a '0' to this bit has no effect.

Writing a '1' to this bit will set the Error Interrupt Enable bit, which enables the Error interrupt.

Value	Description
0	The Error interrupt is disabled.
1	The Error interrupt is enabled.

#### Bit 0 – OVF Overflow Interrupt Enable

Writing a '0' to this bit has no effect.

Writing a '1' to this bit will set the Overflow Interrupt Enable bit, which enables the Overflow interrupt request.

Value	Description
0	The Overflow interrupt is disabled.
1	The Overflow interrupt is enabled.

### 48.7.3.7 Interrupt Flag Status and Clear

**Name:** INTFLAG  
**Offset:** 0x0A  
**Reset:** 0x00  
**Property:** -

	7	6	5	4	3	2	1	0
Access			R/W	R/W			R/W	R/W
Reset			0	0			0	0

#### Bit 5 – MC1 Match or Capture Channel x

This flag is set on a comparison match, or when the corresponding CCx register contains a valid capture value. This flag is set on the next CLK\_TC\_CNT cycle, and will generate an interrupt request if the corresponding Match or Capture Channel x Interrupt Enable bit in the Interrupt Enable Set register (INTENSET.MCx) is '1'.

Writing a '0' to one of these bits has no effect.

Writing a '1' to one of these bits will clear the corresponding Match or Capture Channel x interrupt flag

In capture operation, this flag is automatically cleared when CCx register is read.

#### Bit 4 – MC0 Match or Capture Channel x

This flag is set on a comparison match, or when the corresponding CCx register contains a valid capture value. This flag is set on the next CLK\_TC\_CNT cycle, and will generate an interrupt request if the corresponding Match or Capture Channel x Interrupt Enable bit in the Interrupt Enable Set register (INTENSET.MCx) is '1'.

Writing a '0' to one of these bits has no effect.

Writing a '1' to one of these bits will clear the corresponding Match or Capture Channel x interrupt flag

In capture operation, this flag is automatically cleared when CCx register is read.

#### Bit 1 – ERR Error Interrupt Flag

This flag is set when a new capture occurs on a channel while the corresponding Match or Capture Channel x interrupt flag is set, in which case there is nowhere to store the new capture.

Writing a '0' to this bit has no effect.

Writing a '1' to this bit clears the Error interrupt flag.

#### Bit 0 – OVF Overflow Interrupt Flag

This flag is set on the next CLK\_TC\_CNT cycle after an overflow condition occurs, and will generate an interrupt request if INTENCLR.OVF or INTENSET.OVF is '1'.

Writing a '0' to this bit has no effect.

Writing a '1' to this bit clears the Overflow interrupt flag.

# SAM D5x/E5x Family Data Sheet

## TC – Timer/Counter

### 48.7.3.8 Status

**Name:** STATUS  
**Offset:** 0x0B  
**Reset:** 0x01  
**Property:** Read-Synchronized

	7	6	5	4	3	2	1	0
			CCBUFV1	CCBUFV0	PERBUFV		SLAVE	STOP
Access			R/W	R/W	R/W		R	R
Reset			0	0	0		0	1

**Bits 4, 5 – CCBUFV** Channel x Compare or Capture Buffer Valid

For a compare channel x, the bit x is set when a new value is written to the corresponding CCBUFx register.

The bit x is cleared by writing a '1' to it when CTRLB.LUPD is set, or it is cleared automatically by hardware on UPDATE condition.

For a capture channel x, the bit x is set when a valid capture value is stored in the CCBUFx register. The bit x is cleared automatically when the CCx register is read.

**Bit 3 – PERBUFV** Period Buffer Valid

This bit is set when a new value is written to the PERBUF register. The bit is cleared by writing '1' to the corresponding location when CTRLB.LUPD is set, or automatically cleared by hardware on UPDATE condition. This bit is available only in 8-bit mode and will always read zero in 16- and 32-bit modes.

**Bit 1 – SLAVE** Slave Status Flag

This bit is only available in 32-bit mode on the slave TC (i.e., TC1 and/or TC3). The bit is set when the associated master TC (TC0 and TC2, respectively) is set to run in 32-bit mode.

**Bit 0 – STOP** Stop Status Flag

This bit is set when the TC is disabled, on a Stop command, or on an overflow/underflow condition when the One-Shot bit in the Control B Set register (CTRLBSET.ONESHOT) is '1'.

Value	Description
0	Counter is running.
1	Counter is stopped.

# SAM D5x/E5x Family Data Sheet

## TC – Timer/Counter

### 48.7.3.9 Waveform Generation Control

**Name:** WAVE  
**Offset:** 0x0C  
**Reset:** 0x00  
**Property:** PAC Write-Protection, Enable-Protected

Bit	7	6	5	4	3	2	1	0
							WAVEGEN[1:0]	
Access							R/W	R/W
Reset							0	0

#### Bits 1:0 – WAVEGEN[1:0] Waveform Generation Mode

These bits select the waveform generation operation. They affect the top value, as shown in [48.6.2.6.1 Waveform Output Operations](#). They also control whether frequency or PWM waveform generation should be used. The waveform generation operations are explained in [48.6.2.6.1 Waveform Output Operations](#). These bits are not synchronized.

Value	Name	Operation	Top Value	Output Waveform on Match	Output Waveform on Wraparound
0x0	NFRQ	Normal frequency	PER <sup>1</sup> / Max	Toggle	No action
0x1	MFRQ	Match frequency	CC0	Toggle	No action
0x2	NPWM	Normal PWM	PER <sup>1</sup> / Max	Set	Clear
0x3	MPWM	Match PWM	CC0	Set	Clear

1) This depends on the TC mode: In 8-bit mode, the top value is the Period Value register (PER). In 16- and 32-bit mode it is the respective MAX value.

### 48.7.3.10 Driver Control

**Name:** DRVCTRL  
**Offset:** 0x0D  
**Reset:** 0x00  
**Property:** PAC Write-Protection, Enable-Protected

Bit	7	6	5	4	3	2	1	0
							INVEN1	INVEN0
Access							R/W	R/W
Reset							0	0

**Bits 0, 1 – INVENx** Output Waveform x Invert Enable

Bit x of INVEN[1:0] selects inversion of the output or capture trigger input of channel x.

Value	Description
0	Disable inversion of the WO[x] output and IO input pin.
1	Enable inversion of the WO[x] output and IO input pin.



# SAM D5x/E5x Family Data Sheet

## TC – Timer/Counter

### 48.7.3.11 Debug Control

**Name:** DBGCTRL  
**Offset:** 0x0F  
**Reset:** 0x00  
**Property:** PAC Write-Protection

Bit	7	6	5	4	3	2	1	0
								DBGRUN
Access								R/W
Reset								0

#### Bit 0 – DBGRUN Run in Debug Mode

This bit is not affected by a software Reset, and should not be changed by software while the TC is enabled.

Value	Description
0	The TC is halted when the device is halted in debug mode.
1	The TC continues normal operation when the device is halted in debug mode.

### 48.7.3.12 Synchronization Busy

**Name:** SYNCBUSY  
**Offset:** 0x10  
**Reset:** 0x00000000  
**Property:** -

Bit	31	30	29	28	27	26	25	24
Access								
Reset								
Bit	23	22	21	20	19	18	17	16
Access								
Reset								
Bit	15	14	13	12	11	10	9	8
Access								
Reset								
Bit	7	6	5	4	3	2	1	0
	CC1	CC0		COUNT	STATUS	CTRLB	ENABLE	SWRST
Access	R	R		R	R	R	R	R
Reset	0	0		0	0	0	0	0

**Bits 6, 7 – CCx** Compare/Capture Channel x Synchronization Busy

For details on CC channels number, refer to each TC feature list.

This bit is set when the synchronization of CCx between clock domains is started.

This bit is also set when the CCBUFx is written, and cleared on update condition. The bit is automatically cleared when the STATUS.CCBUFx bit is cleared.

**Bit 4 – COUNT** COUNT Synchronization Busy

This bit is cleared when the synchronization of COUNT between the clock domains is complete.

This bit is set when the synchronization of COUNT between clock domains is started.

**Bit 3 – STATUS** STATUS Synchronization Busy

This bit is cleared when the synchronization of STATUS between the clock domains is complete.

This bit is set when a '1' is written to the Capture Channel Buffer Valid status flags (STATUS.CCBUFVx) and the synchronization of STATUS between clock domains is started.

**Bit 2 – CTRLB** CTRLB Synchronization Busy

This bit is cleared when the synchronization of CTRLB between the clock domains is complete.

This bit is set when the synchronization of CTRLB between clock domains is started.

**Bit 1 – ENABLE** ENABLE Synchronization Busy

This bit is cleared when the synchronization of ENABLE bit between the clock domains is complete.

This bit is set when the synchronization of ENABLE bit between clock domains is started.

**Bit 0 – SWRST** SWRST Synchronization Busy

This bit is cleared when the synchronization of SWRST bit between the clock domains is complete.

This bit is set when the synchronization of SWRST bit between clock domains is started.

# SAM D5x/E5x Family Data Sheet

## TC – Timer/Counter

### 48.7.3.13 Counter Value, 32-bit Mode

**Name:** COUNT  
**Offset:** 0x14  
**Reset:** 0x00  
**Property:** PAC Write-Protection, Write-Synchronized, Read-Synchronized

**Note:** Prior to any read access, this register must be synchronized by user by writing the according TC Command value to the Control B Set register (CTRLBSET.CMD=READSYNC).

Bit	31	30	29	28	27	26	25	24
COUNT[31:24]								
Access	R/W	R/W	R/W	R/W	R/W	R/W	R/W	R/W
Reset	0	0	0	0	0	0	0	0
Bit	23	22	21	20	19	18	17	16
COUNT[23:16]								
Access	R/W	R/W	R/W	R/W	R/W	R/W	R/W	R/W
Reset	0	0	0	0	0	0	0	0
Bit	15	14	13	12	11	10	9	8
COUNT[15:8]								
Access	R/W	R/W	R/W	R/W	R/W	R/W	R/W	R/W
Reset	0	0	0	0	0	0	0	0
Bit	7	6	5	4	3	2	1	0
COUNT[7:0]								
Access	R/W	R/W	R/W	R/W	R/W	R/W	R/W	R/W
Reset	0	0	0	0	0	0	0	0

**Bits 31:0 – COUNT[31:0]** Counter Value  
 These bits contain the current counter value.

### 48.7.3.14 Channel x Compare/Capture Value, 32-bit Mode

**Name:** CCx  
**Offset:** 0x1C + x\*0x04 [x=0..1]  
**Reset:** 0x00000000  
**Property:** Write-Synchronized

	Bit	31	30	29	28	27	26	25	24
		CC[31:24]							
Access		R/W	R/W	R/W	R/W	R/W	R/W	R/W	R/W
Reset		0	0	0	0	0	0	0	0
	Bit	23	22	21	20	19	18	17	16
		CC[23:16]							
Access		R/W	R/W	R/W	R/W	R/W	R/W	R/W	R/W
Reset		0	0	0	0	0	0	0	0
	Bit	15	14	13	12	11	10	9	8
		CC[15:8]							
Access		R/W	R/W	R/W	R/W	R/W	R/W	R/W	R/W
Reset		0	0	0	0	0	0	0	0
	Bit	7	6	5	4	3	2	1	0
		CC[7:0]							
Access		R/W	R/W	R/W	R/W	R/W	R/W	R/W	R/W
Reset		0	0	0	0	0	0	0	0

**Bits 31:0 – CC[31:0]** Channel x Compare/Capture Value

These bits contain the compare/capture value in 32-bit TC mode. In Match frequency (MFRQ) or Match PWM (MPWM) waveform operation (WAVE.WAVEGEN), the CC0 register is used as a period register.

### 48.7.3.15 Channel x Compare Buffer Value, 32-bit Mode

**Name:** CCBUFx  
**Offset:** 0x30 + x\*0x04 [x=0..1]  
**Reset:** 0x00000000  
**Property:** Write-Synchronized

	Bit	31	30	29	28	27	26	25	24
		CCBUF[31:24]							
Access		R/W	R/W	R/W	R/W	R/W	R/W	R/W	R/W
Reset		0	0	0	0	0	0	0	0
	Bit	23	22	21	20	19	18	17	16
		CCBUF[23:16]							
Access		R/W	R/W	R/W	R/W	R/W	R/W	R/W	R/W
Reset		0	0	0	0	0	0	0	0
	Bit	15	14	13	12	11	10	9	8
		CCBUF[15:8]							
Access		R/W	R/W	R/W	R/W	R/W	R/W	R/W	R/W
Reset		0	0	0	0	0	0	0	0
	Bit	7	6	5	4	3	2	1	0
		CCBUF[7:0]							
Access		R/W	R/W	R/W	R/W	R/W	R/W	R/W	R/W
Reset		0	0	0	0	0	0	0	0

**Bits 31:0 – CCBUF[31:0]** Channel x Compare Buffer Value

These bits hold the value of the Channel x Compare Buffer Value. When the buffer valid flag is '1' and double buffering is enabled (CTRLBCLR.LUPD=1), the data from buffer registers will be copied into the corresponding CCx register under UPDATE condition (CTRLBSET.CMD=0x3), including the software update command.

## 49. TCC – Timer/Counter for Control Applications

### 49.1 Overview

The device provides five instances of the Timer/Counter for Control applications (TCC) peripheral, TCC[4:0].

Each TCC instance consists of a counter, a prescaler, compare/capture channels and control logic. The counter can be set to count events or clock pulses. The counter together with the compare/capture channels can be configured to time stamp input events, allowing capture of frequency and pulse-width. It can also perform waveform generation, such as frequency generation and pulse-width modulation.

Waveform extensions are featured for motor control, ballast, LED, H-bridge, power converters, and other types of power control applications. They allow for low-side and high-side output with optional dead-time insertion. Waveform extensions can also generate a synchronized bit pattern across the waveform output pins. The fault options enable fault protection for safe and deterministic handling, disabling and/or shut down of external drivers.

**Note:** The TCC configurations, such as channel numbers and features, may be reduced for some of the TCC instances.

#### Related Links

[6.2.7 TCC Configurations](#)

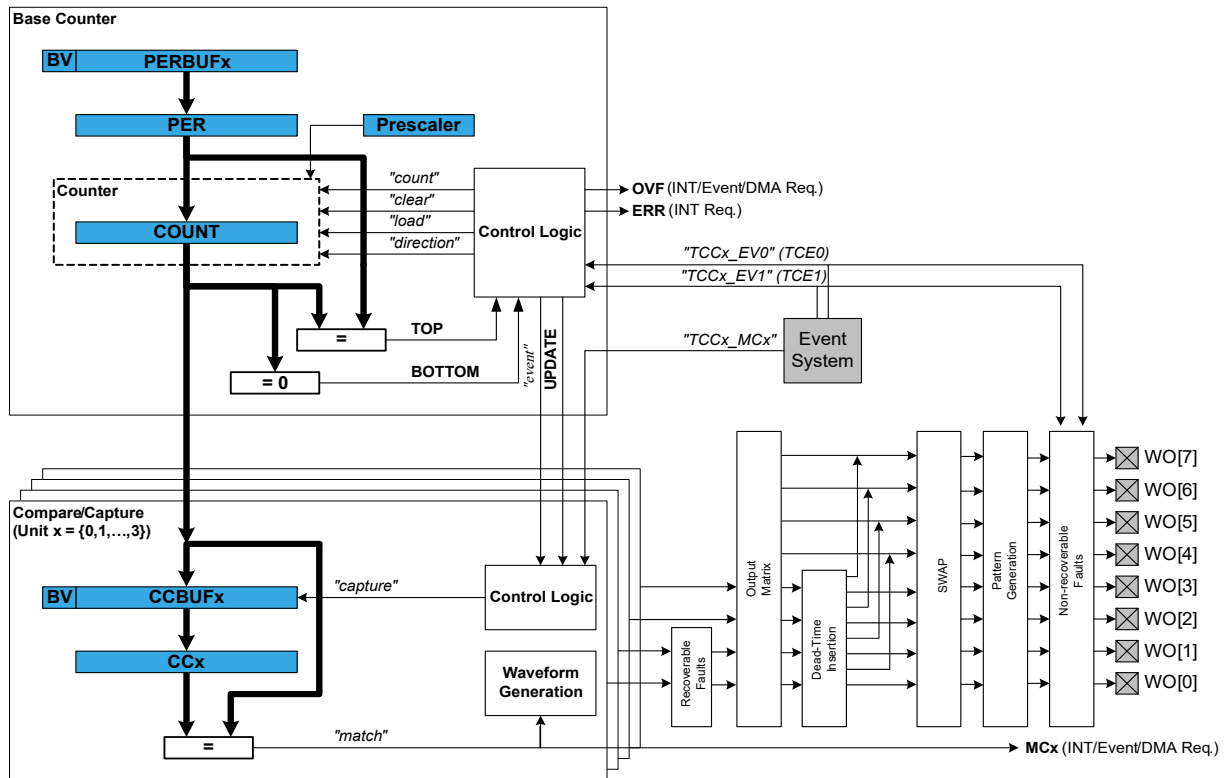
### 49.2 Features

- Up to six Compare/Capture Channels (CC) with:
  - Double buffered period setting
  - Double buffered compare or capture channel
  - Circular buffer on period and compare channel registers
- Waveform Generation:
  - Frequency generation
  - Single-slope pulse-width modulation (PWM)
  - Dual-slope PWM with half-cycle reload capability
- Input Capture:
  - Event capture
  - Frequency capture
  - Pulse-width capture
- Waveform Extensions:
  - Configurable distribution of compare channels outputs across port pins
  - Low-side and high-side output with programmable dead-time insertion
  - Waveform swap option with double buffer support
  - Pattern generation with double buffer support
  - Dithering support
- Fault Protection for Safe Disabling of Drivers:
  - Two recoverable fault sources

- Two non-recoverable fault sources
- Debugger can be a source of non-recoverable fault
- Input Events:
  - Two input events (EVx) for counter
  - One input event (MCx) for each channel
- Output Events:
  - Three output events (Count, re-trigger and overflow) are available for counter
  - One compare match/input capture event output for each channel
- Interrupts:
  - Overflow and re-trigger interrupt
  - Compare match/input capture interrupt
  - Interrupt on fault detection

### 49.3 Block Diagram

Figure 49-1. Timer/Counter for Control Applications - Block Diagram



### 49.4 Signal Description

Pin Name	Type	Description
TCC/WO[0]	Digital output	Compare channel 0 waveform output
TCC/WO[1]	Digital output	Compare channel 1 waveform output



# SAM D5x/E5x Family Data Sheet

## TCC – Timer/Counter for Control Applications

.....continued		
Pin Name	Type	Description
...	...	...
TCC/WO[WO_NUM-1]	Digital output	Compare channel n waveform output

Refer to *I/O Multiplexing and Considerations* for details on the pin mapping for this peripheral. One signal can be mapped on several pins.

### Related Links

[6. I/O Multiplexing and Considerations](#)

## 49.5 Product Dependencies

In order to use this peripheral, other parts of the system must be configured correctly, as described below.

### 49.5.1 I/O Lines

In order to use the I/O lines of this peripheral, the I/O pins must be configured using the I/O Pin Controller (PORT).

#### Related Links

[32. PORT - I/O Pin Controller](#)

### 49.5.2 Power Management

This peripheral can continue to operate in any Sleep mode where its source clock is running. The interrupts can wake up the device from Sleep modes. Events connected to the event system can trigger other operations in the system without exiting Sleep modes.

### 49.5.3 Clocks

The TCC bus clocks (CLK\_TCCx\_APB) can be enabled and disabled in the Main Clock module. The default state of CLK\_TCCx\_APB can be found in the Peripheral Clock Masking section (see the Related Links below).

A generic clock (GCLK\_TCCx) is required to clock the TCC. This clock must be configured and enabled in the generic clock controller before using the TCC.

The generic clocks (GCLK\_TCCx) are asynchronous to the bus clock (CLK\_TCCx\_APB). Due to this asynchronicity, writing certain registers will require synchronization between the clock domains. Refer to [49.6.7 Synchronization](#) for further details.

#### Related Links

[15.6.2.6 Peripheral Clock Masking](#)

[14. GCLK - Generic Clock Controller](#)

### 49.5.4 DMA

The DMA request lines are connected to the DMA Controller (DMAC). In order to use DMA requests with this peripheral the DMAC must be configured first. Refer to *DMAC – Direct Memory Access Controller* for details.

#### Related Links

[22. DMAC – Direct Memory Access Controller](#)

### 49.5.5 Interrupts

The interrupt request line is connected to the Interrupt Controller. In order to use interrupt requests of this peripheral, the Interrupt Controller (NVIC) must be configured first. Refer to *Nested Vector Interrupt Controller* for details.

#### Related Links

[10.2 Nested Vector Interrupt Controller](#)

### 49.5.6 Events

The events of this peripheral are connected to the Event System.

#### Related Links

[31. EVSYS – Event System](#)

### 49.5.7 Debug Operation

When the CPU is halted in Debug mode, this peripheral will halt normal operation. This peripheral can be forced to continue operation during debugging - refer to the Debug Control (DBGCTRL) register for details.

Refer to [49.8.8 DBGCTRL](#) register for details.

### 49.5.8 Register Access Protection

Registers with write access can be optionally write-protected by the Peripheral Access Controller (PAC), except for the following:

- Interrupt Flag register (INTFLAG)
- Status register (STATUS)
- Period and Period Buffer registers (PER, PERBUF)
- Compare/Capture and Compare/Capture Buffer registers (CCx, CCBUFx)
- Control Waveform register (WAVE)
- Pattern Generation Value and Pattern Generation Value Buffer registers (PATT, PATTBUF)

**Note:** Optional write protection is indicated by the "PAC Write Protection" property in the register description.

Write protection does not apply for accesses through an external debugger.

### 49.5.9 Analog Connections

Not applicable.

## 49.6 Functional Description

### 49.6.1 Principle of Operation

The following definitions are used throughout the documentation:

# SAM D5x/E5x Family Data Sheet

## TCC – Timer/Counter for Control Applications

**Table 49-1. Timer/Counter for Control Applications - Definitions**

Name	Description
TOP	The counter reaches TOP when it becomes equal to the highest value in the count sequence. The TOP value can be the same as Period (PER) or the Compare Channel 0 (CC0) register value depending on the Waveform Generator mode in <a href="#">49.6.2.5.1 Waveform Output Generation Operations</a> .
ZERO	The counter reaches ZERO when it contains all zeroes.
MAX	The counter reaches maximum when it contains all ones.
UPDATE	The timer/counter signals an update when it reaches ZERO or TOP, depending on the direction settings.
Timer	The timer/counter clock control is handled by an internal source.
Counter	The clock control is handled externally (e.g., counting external events).
CC	For compare operations, the CC are referred to as "compare channels." For capture operations, the CC are referred to as "capture channels."

Each TCC instance has up to four compare/capture channels (CCx).

The Counter register (COUNT), Period registers with Buffer (PER and PERBUF), and Compare and Capture registers with buffers (CCx and CCBUFx) are 16- or 24-bit registers, depending on each TCC instance. Each Buffer register has a Buffer Valid (BUFV) flag that indicates when the buffer contains a new value.

Under normal operation, the counter value is continuously compared to the TOP or ZERO value to determine whether the counter has reached TOP or ZERO. In either case, the TCC can generate interrupt requests or generate events for the Event System. In Waveform Generator mode, these comparisons are used to set the waveform period or pulse width.

A prescaled generic clock (GCLK\_TCCx) and events from the event system can be used to control the counter. The event system is also used as a source to the input capture.

The Recoverable Fault Unit enables event controlled waveforms by acting directly on the generated waveforms of the TCC compare channels output. These events can restart, halt the timer/counter period, shorten the output pulse active time, or disable waveform output as long as the fault condition is present. This can typically be used for current sensing regulation, and zero-crossing and demagnetization re-triggering.

The MCE0 and MCE1 asynchronous event sources are shared with the recoverable fault unit. Only asynchronous events are used internally when fault unit extension is enabled. For further details on how to configure asynchronous events routing, refer to *EVSYS – Event System*.

Recoverable fault sources can be filtered and/or windowed to avoid false triggering, for example from I/O pin glitches, by using digital filtering, input blanking, and qualification options. See also [49.6.3.5 Recoverable Faults](#).

In order to support applications with different types of motor control, ballast, LED, H-bridge, power converter, and other types of power switching applications, the following independent units are implemented in some of the TCC instances as optional and successive units:

# SAM D5x/E5x Family Data Sheet

## TCC – Timer/Counter for Control Applications

---

- Recoverable faults and non-recoverable faults
- Output matrix
- Dead-time insertion
- Swap
- Pattern generation

See also [Figure 49-1](#).

The output matrix (OTMX) can distribute and route out the TCC waveform outputs across the port pins in different configurations, each optimized for different application types. The Dead-Time Insertion (DTI) unit splits the four lower OTMX outputs into two non-overlapping signals: the non-inverted Low Side (LS) and inverted High Side (HS) of the waveform output with optional dead-time insertion between LS and HS switching. The SWAP unit can swap the LS and HS pin outputs, and can be used for fast decay motor control.

The pattern generation unit can be used to generate synchronized waveforms with constant logic level on TCC UPDATE conditions. This is useful for easy stepper motor and full bridge control.

The non-recoverable fault module enables event controlled fault protection by acting directly on the generated waveforms of the timer/counter compare channel outputs. When a non-recoverable fault condition is detected, the output waveforms are forced to a preconfigured value that is safe for the application. This is typically used for instant and predictable shut down and disabling high current or voltage drives.

The count event sources (TCE0 and TCE1) are shared with the non-recoverable fault extension. The events can be optionally filtered. If the filter options are not used, the non-recoverable faults provide an immediate asynchronous action on waveform output, even for cases where the clock is not present. For further details on how to configure asynchronous events routing, refer to section *EVSYS – Event System*.

### Related Links

[31. EVSYS – Event System](#)

## 49.6.2 Basic Operation

### 49.6.2.1 Initialization

The following registers are enable-protected, meaning that they can only be written when the TCC is disabled (CTRLA.ENABLE=0):

- Control A (CTRLA) register, except Run Standby (RUNSTDBY), Enable (ENABLE) and Software Reset (SWRST) bits
- Recoverable Fault n Control registers (FCTRLA and FCTRLB)
- Waveform Extension Control register (WEXCTRL)
- Drive Control register (DRVCTRL)
- Event Control register (EVCTRL)

Enable-protected bits in the CTRLA register can be written at the same time as CTRLA.ENABLE is written to '1', but not at the same time as CTRLA.ENABLE is written to '0'. Enable-protection is denoted by the “Enable-Protected” property in the register description.

Before the TCC is enabled, it must be configured as outlined by the following steps:

1. Enable the TCC bus clock (CLK\_TCCx\_APB).
2. If Capture mode is required, enable the channel in Capture mode by writing a '1' to the Capture Enable bit in the Control A register (CTRLA.CPTEN).

Optionally, the following configurations can be set before enabling TCC:

1. Select PRESCALER setting in the Control A register (CTRLA.PRESCALER).
2. Select Prescaler Synchronization setting in Control A register (CTRLA.PRESCSYNC).
3. If down-counting operation is desired, write the Counter Direction bit in the Control B Set register (CTRLBSET.DIR) to '1'.
4. Select the Waveform Generation operation in the WAVE register (WAVE.WAVEGEN).
5. Select the Waveform Output Polarity in the WAVE register (WAVE.POL).
6. The waveform output can be inverted for the individual channels using the Waveform Output Invert Enable bit group in the Driver register (DRVCTRL.INVEN).

### 49.6.2.2 Enabling, Disabling, and Resetting

The TCC is enabled by writing a '1' to the Enable bit in the Control A register (CTRLA.ENABLE). The TCC is disabled by writing a zero to CTRLA.ENABLE.

The TCC is reset by writing '1' to the Software Reset bit in the Control A register (CTRLA.SWRST). All registers in the TCC, except DBGCTRL, will be reset to their initial state, and the TCC will be disabled. Refer to Control A (49.8.1 CTRLA) register for details.

The TCC should be disabled before the TCC is reset to avoid undefined behavior.

### 49.6.2.3 Prescaler Selection

The GCLK\_TCCx clock is fed into the internal prescaler.

The prescaler consists of a counter that counts up to the selected prescaler value, whereupon the output of the prescaler toggles.

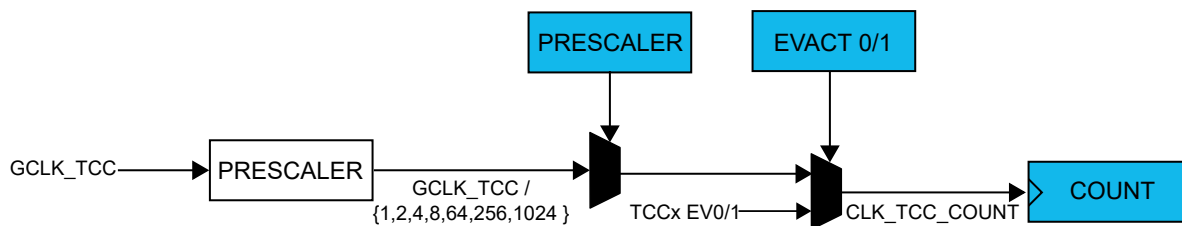
If the prescaler value is higher than one, the Counter Update condition can be optionally executed on the next GCLK\_TCC clock pulse or the next prescaled clock pulse. For further details, refer to the Prescaler (CTRLA.PRESCALER) and Counter Synchronization (CTRLA.PRESYNC) descriptions.

Prescaler outputs from 1 to 1/1024 are available. For a complete list of available prescaler outputs, see the register description for the Prescaler bit group in the Control A register (CTRLA.PRESCALER).

**Note:** When counting events, the prescaler is bypassed.

The joint stream of prescaler ticks and event action ticks is called CLK\_TCC\_COUNT.

**Figure 49-2. Prescaler**



### 49.6.2.4 Counter Operation

Depending on the mode of operation, the counter is cleared, reloaded, incremented, or decremented at each TCC clock input (CLK\_TCC\_COUNT). A counter clear or reload mark the end of current counter cycle and the start of a new one.

The counting direction is set by the Direction bit in the Control B register (CTRLB.DIR). If the bit is zero, it's counting up and one if counting down.

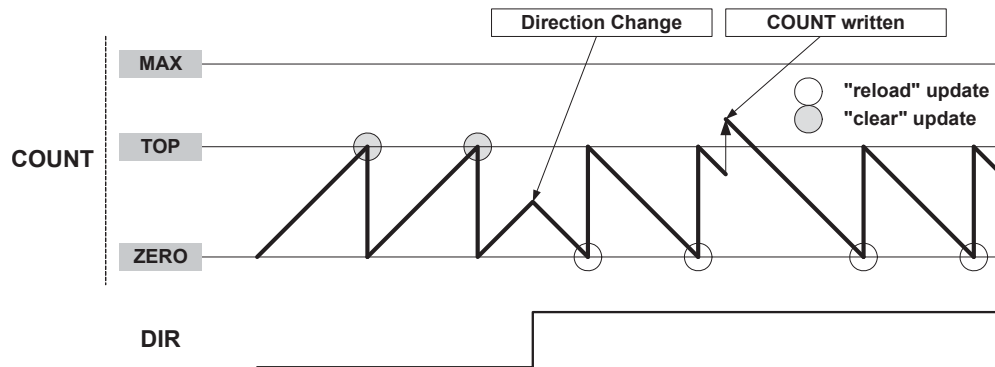
# SAM D5x/E5x Family Data Sheet

## TCC – Timer/Counter for Control Applications

The counter will count up or down for each tick (clock or event) until it reaches TOP or ZERO. When it's counting up and TOP is reached, the counter will be set to zero at the next tick (overflow) and the Overflow Interrupt Flag in the Interrupt Flag Status and Clear register (INTFLAG.OVF) will be set. When down-counting, the counter is reloaded with the TOP value when ZERO is reached (underflow), and INTFLAG.OVF is set.

INTFLAG.OVF can be used to trigger an interrupt, or an event. An overflow/underflow occurrence (i.e. a compare match with TOP/ZERO) will stop counting if the One-Shot bit in the Control B register is set (CTRLBSET.ONESHOT). The One-Shot feature is explained in the [Additional Features](#) section.

**Figure 49-3. Counter Operation**



It is possible to change the counter value (by writing directly in the COUNT register) even when the counter is running. The COUNT value will always be ZERO or TOP, depending on direction set by CTRLBSET.DIR or CTRLBCLR.DIR, when starting the TCC, unless a different value has been written to it, or the TCC has been stopped at a value other than ZERO. The write access has higher priority than count, clear, or reload. The direction of the counter can also be changed during normal operation. See also [Figure 49-3](#).

### Stop Command

A stop command can be issued from software by using TCC Command bits in Control B Set register (CTRLBSET.CMD=0x2, STOP).

When a stop is detected while the counter is running, the counter will maintain its current value. If the waveform generation (WG) is used, all waveforms are set to a state defined in Non-Recoverable State x Output Enable bit and Non-Recoverable State x Output Value bit in the Driver Control register (DRVCTRL.NREx and DRVCTRL.NRVx), and the Stop bit in the Status register is set (STATUS.STOP).

### Pause Event Action

A pause command can be issued when the stop event action is configured in the Input Event Action 1 bits in Event Control register (EVCTRL.EVACT1=0x3, STOP).

When a pause is detected, the counter can stop immediately maintaining its current value and all waveforms keep their current state, as long as a start event action is detected: Input Event Action 0 bits in Event Control register (EVCTRL.EVACT0=0x3, START).

### Re-Trigger Command and Event Action

A re-trigger command can be issued from software by using TCC Command bits in Control B Set register (CTRLBSET.CMD=0x1, RETRIGGER), or from event when the re-trigger event action is configured in the Input Event 0/1 Action bits in Event Control register (EVCTRL.EVACTn=0x1, RETRIGGER).

# SAM D5x/E5x Family Data Sheet

## TCC – Timer/Counter for Control Applications

---

When the command is detected during counting operation, the counter will be reloaded or cleared, depending on the counting direction (CTRLBSET.DIR or CTRLBCLR.DIR). The Re-Trigger bit in the Interrupt Flag Status and Clear register will be set (INTFLAG.TRG). It is also possible to generate an event by writing a '1' to the Re-Trigger Event Output Enable bit in the Event Control register (EVCTRL.TRGEO). If the re-trigger command is detected when the counter is stopped, the counter will resume counting operation from the value in COUNT.

### **Note:**

When a re-trigger event action is configured in the Event Action bits in the Event Control register (EVCTRL.EVACTn=0x1, RETRIGGER), enabling the counter will not start the counter. The counter will start on the next incoming event and restart on corresponding following event.

### **Start Event Action**

The start action can be selected in the Event Control register (EVCTRL.EVACT0=0x3, START) and can start the counting operation when previously stopped. The event has no effect if the counter is already counting. When the module is enabled, the counter operation starts when the event is received or when a re-trigger software command is applied.

### **Note:**

When a start event action is configured in the Event Action bits in the Event Control register (EVCTRL.EVACT0=0x3, START), enabling the counter will not start the counter. The counter will start on the next incoming event, but it will not restart on subsequent events.

### **Count Event Action**

The TCC can count events. When an event is received, the counter increases or decreases the value, depending on direction settings (CTRLBSET.DIR or CTRLBCLR.DIR).

The count event action is selected by the Event Action 0 bit group in the Event Control register (EVCTRL.EVACT0=0x5, COUNT).

### **Direction Event Action**

The direction event action can be selected in the Event Control register (EVCTRL.EVACT1=0x2, DIR). When this event is used, the asynchronous event path specified in the event system must be configured or selected. The direction event action can be used to control the direction of the counter operation, depending on external events level. When received, the event level overrides the Direction settings (CTRLBSET.DIR or CTRLBCLR.DIR) and the direction bit value is updated accordingly.

### **Increment Event Action**

The increment event action can be selected in the Event Control register (EVCTRL.EVACT0=0x4, INC) and can change the Counter state when an event is received. When the TCE0 event (TCCx\_EV0) is received, the counter increments, whatever the direction setting (CTRLBSET.DIR or CTRLBCLR.DIR) is.

### **Decrement Event Action**

The decrement event action can be selected in the Event Control register (EVCTRL.EVACT1=0x4, DEC) and can change the Counter state when an event is received. When the TCE1 (TCCx\_EV1) event is received, the counter decrements, whatever the direction setting (CTRLBSET.DIR or CTRLBCLR.DIR) is.

### **Non-recoverable Fault Event Action**

Non-recoverable fault actions can be selected in the Event Control register (EVCTRL.EVACTn=0x7, FAULT). When received, the counter will be stopped and the output of the compare channels is

# SAM D5x/E5x Family Data Sheet

## TCC – Timer/Counter for Control Applications

---

overridden according to the Driver Control register settings (DRVCTRL.NREx and DRVCTRL.NRVx). TCE0 and TCE1 must be configured as asynchronous events.

### Event Action Off

If the event action is disabled (EVCTRL.EVACTn=0x0, OFF), enabling the counter will also start the counter.

### Related Links

[49.6.3.1 One-Shot Operation](#)

### 49.6.2.5 Compare Operations

By default, the Compare/Capture channel is configured for compare operations. To perform capture operations, it must be re-configured.

When using the TCC with the Compare/Capture Value registers (CCx) for compare operations, the counter value is continuously compared to the values in the CCx registers. This can be used for timer or for waveform operation.

The Channel x Compare/Capture Buffer Value (CCBUFx) registers provide double buffer capability. The double buffering synchronizes the update of the CCx register with the buffer value at the UPDATE condition or a force update command (CTRLBSET.CMD=0x3, UPDATE). For further details, refer to [49.6.2.6 Double Buffering](#). The synchronization prevents the occurrence of odd-length, non-symmetrical pulses and ensures glitch-free output.

#### 49.6.2.5.1 Waveform Output Generation Operations

The compare channels can be used for waveform generation on output port pins. To make the waveform available on the connected pin, the following requirements must be fulfilled:

1. Choose a Waveform Generation mode in the Waveform Generation Operation bit in Waveform register (WAVE.WAVEGEN).
2. Optionally invert the waveform output WO[x] by writing the corresponding Waveform Output x Inversion bit in the Driver Control register (DRVCTRL.INVENx).
3. Configure the pins with the I/O Pin Controller. Refer to *PORT - I/O Pin Controller* for details.

**Note:** Event must not be used when the compare channel is set in waveform output operating mode.

The counter value is continuously compared with each CCx value. On a comparison match, the Match or Capture Channel x bit in the Interrupt Flag Status and Clear register (INTFLAG.MCx) will be set on the next zero-to-one transition of CLK\_TCC\_COUNT (see Normal Frequency Operation). An interrupt and/or event can be generated on the same condition if Match/Capture occurs, i.e. INTENSET.MCx and/or EVCTRL.MCE0x is '1'. Both interrupt and event can be generated simultaneously.

There are seven waveform configurations for the Waveform Generation Operation bit group in the Waveform register (WAVE.WAVEGEN). This will influence how the waveform is generated and impose restrictions on the top value. The configurations are:

- Normal Frequency (NFRQ)
- Match Frequency (MFRQ)
- Normal Pulse-Width Modulation (NPWM)
- Dual-slope, interrupt/event at TOP (DSTOP)
- Dual-slope, interrupt/event at ZERO (DSBOTTOM)
- Dual-slope, interrupt/event at Top and ZERO (DSBOTH)
- Dual-slope, critical interrupt/event at ZERO (DSCRITICAL)



# SAM D5x/E5x Family Data Sheet

## TCC – Timer/Counter for Control Applications

When using MFRQ configuration, the TOP value is defined by the CC0 register value. For the other waveform operations, the TOP value is defined by the Period (PER) register value.

For dual-slope waveform operations, the update time occurs when the counter reaches ZERO. For the other Waveforms Generation modes, the update time occurs on counter wraparound, on overflow, underflow, or re-trigger.

The table below shows the update counter and overflow event/interrupt generation conditions in different operation modes.

**Table 49-2. Counter Update and Overflow Event/interrupt Conditions**

Name	Operation	TOP	Update	Output Waveform		OVFIF/Event	
				On Match	On Update	Up	Down
NFRQ	Normal Frequency	PER	TOP/ ZERO	Toggle	Stable	TOP	ZERO
MFRQ	Match Frequency	CC0	TOP/ ZERO	Toggle	Stable	TOP	ZERO
NPWM	Single-slope PWM	PER	TOP/ ZERO	See section 'Output Polarity' below		TOP	ZERO
DSCRITICAL	Dual-slope PWM	PER	ZERO			-	ZERO
DSBOTTOM	Dual-slope PWM	PER	ZERO			-	ZERO
DSBOTH	Dual-slope PWM	PER	TOP <sup>(1)</sup> & ZERO			TOP	ZERO
DSTOP	Dual-slope PWM	PER	ZERO			TOP	-

1. The UPDATE condition on TOP only will occur when circular buffer is enabled for the channel.

### Related Links

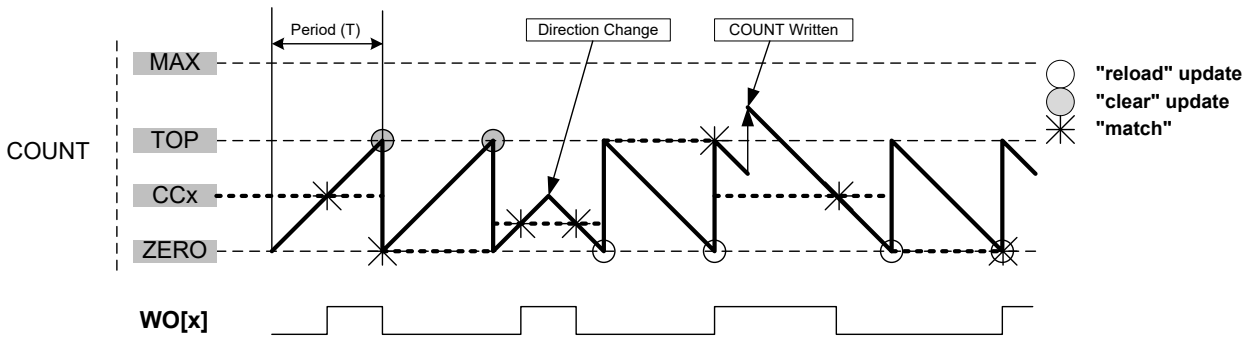
[49.6.3.2 Circular Buffer](#)

[32. PORT - I/O Pin Controller](#)

#### 49.6.2.5.2 Normal Frequency (NFRQ)

For Normal Frequency generation, the period time (T) is controlled by the period register (PER). The waveform generation output (WO[x]) is toggled on each compare match between COUNT and CCx, and the corresponding Match or Capture Channel x Interrupt Flag (EVCTRL.MCEOx) will be set.

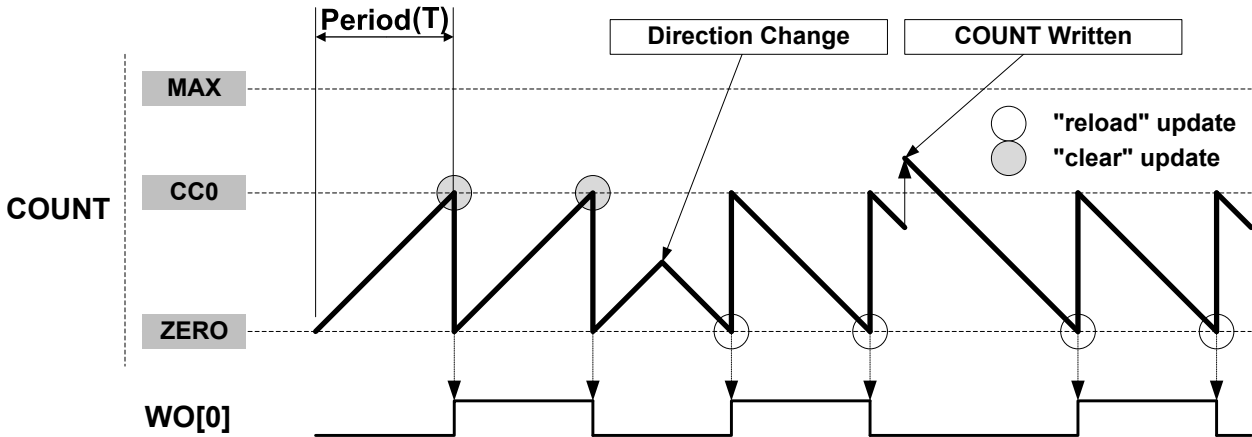
**Figure 49-4. Normal Frequency Operation**



### 49.6.2.5.3 Match Frequency (MFRQ)

For Match Frequency generation, the period time (T) is controlled by CC0 register instead of PER. WO[0] toggles on each update condition.

**Figure 49-5. Match Frequency Operation**



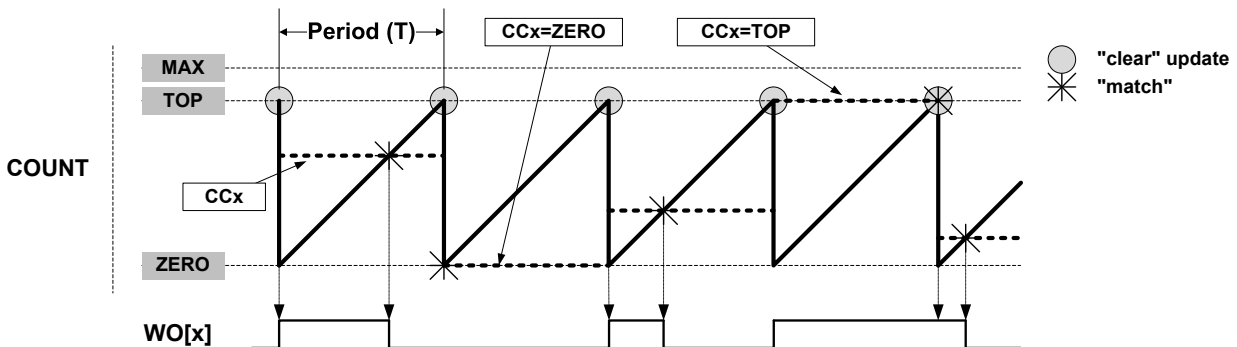
### 49.6.2.5.4 Normal Pulse-Width Modulation (NPWM)

NPWM uses single-slope PWM generation.

### 49.6.2.5.5 Single-Slope PWM Operation

For single-slope PWM generation, the period time (T) is controlled by Top value, and CCx controls the duty cycle of the generated waveform output. When up-counting, the WO[x] is set at start or compare match between the COUNT and TOP values, and cleared on compare match between COUNT and CCx register values. When down-counting, the WO[x] is cleared at start or compare match between the COUNT and ZERO values, and set on compare match between COUNT and CCx register values.

**Figure 49-6. Single-Slope PWM Operation**



The following equation calculates the exact resolution for a single-slope PWM ( $R_{PWM\_SS}$ ) waveform:

$$R_{PWM\_SS} = \frac{\log(TOP+1)}{\log(2)}$$

The PWM frequency depends on the Period register value (PER) and the peripheral clock frequency ( $f_{GCLK\_TCC}$ ), and can be calculated by the following equation:

$$f_{PWM\_SS} = \frac{f_{GCLK\_TCC}}{N(TOP+1)}$$

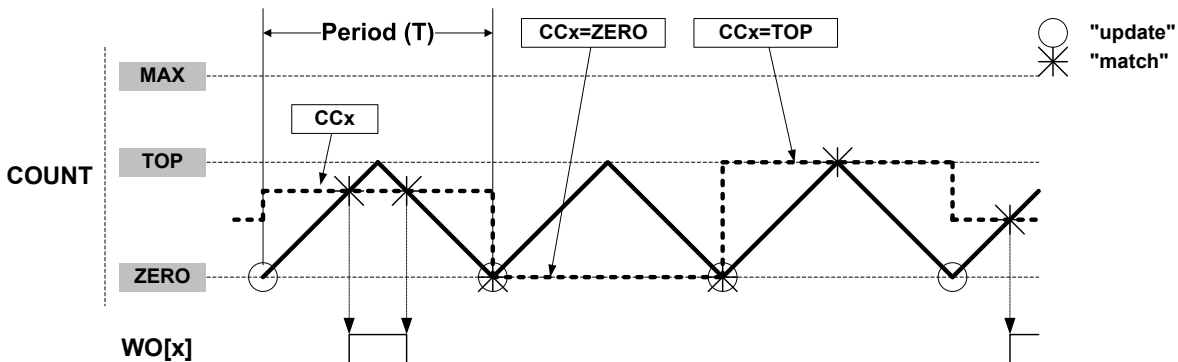
Where N represents the prescaler divider used (1, 2, 4, 8, 16, 64, 256, 1024).

#### 49.6.2.5.6 Dual-Slope PWM Generation

For dual-slope PWM generation, the period setting (TOP) is controlled by PER, while CCx control the duty cycle of the generated waveform output. The figure below shows how the counter repeatedly counts from ZERO to PER and then from PER to ZERO. The waveform generator output is set on compare match when up-counting, and cleared on compare match when down-counting. An interrupt and/or event is generated on TOP (when counting upwards) and/or ZERO (when counting up or down).

In DSBOTH operation, the circular buffer must be enabled to enable the update condition on TOP.

**Figure 49-7. Dual-Slope Pulse Width Modulation**



Using dual-slope PWM results in a lower maximum operation frequency compared to single-slope PWM generation. The period (TOP) defines the PWM resolution. The minimum resolution is 1 bit (TOP=0x00000001).

The following equation calculates the exact resolution for dual-slope PWM ( $R_{PWM\_DS}$ ):

$$R_{PWM\_DS} = \frac{\log(PER+1)}{\log(2)}$$

The PWM frequency  $f_{PWM\_DS}$  depends on the period setting (TOP) and the peripheral clock frequency  $f_{GCLK\_TCC}$ , and can be calculated by the following equation:

$$f_{PWM\_DS} = \frac{f_{GCLK\_TCC}}{2N \cdot PER}$$

N represents the prescaler divider used. The waveform generated will have a maximum frequency of half of the TCC clock frequency ( $f_{GCLK\_TCC}$ ) when TOP is set to 0x00000001 and no prescaling is used.

The pulse width ( $P_{PWM\_DS}$ ) depends on the compare channel (CCx) register value and the peripheral clock frequency ( $f_{GCLK\_TCC}$ ), and can be calculated by the following equation:

$$P_{PWM\_DS} = \frac{2N \cdot (TOP - CCx)}{f_{GCLK\_TCC}}$$

$N$  represents the prescaler divider used.

**Note:** In DSTOP, DSBOTTOM and DSBOTH operation, when TOP is lower than MAX/2, the CCx MSB bit defines the ramp on which the CCx Match interrupt or event is generated. (Rising if CCx[MSB] = 0, falling if CCx[MSB] = 1.)

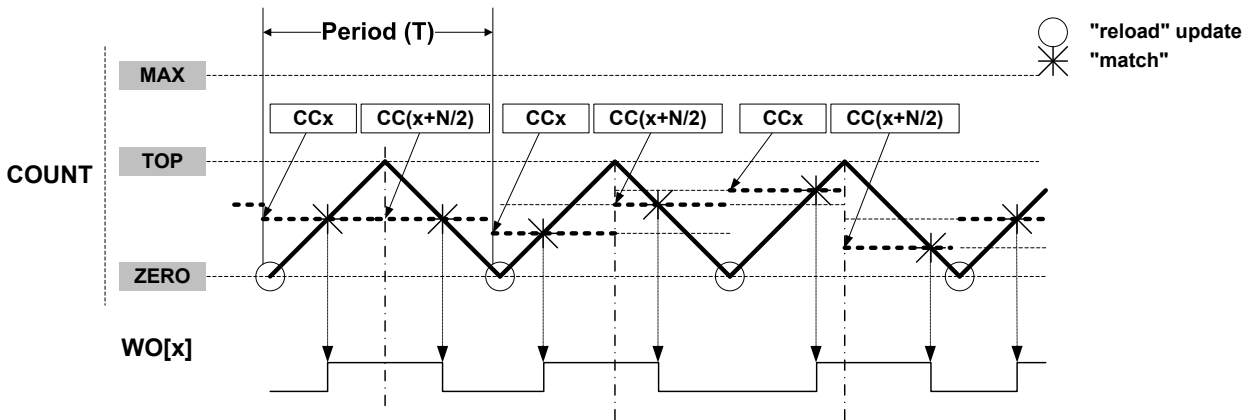
**Related Links**

[49.6.3.2 Circular Buffer](#)

**49.6.2.5.7 Dual-Slope Critical PWM Generation**

Critical mode generation allows generation of non-aligned centered pulses. In this mode, the period time is controlled by PER while CCx control the generated waveform output edge during up-counting and CC(x+CC\_NUM/2) control the generated waveform output edge during down-counting.

**Figure 49-8. Dual-Slope Critical Pulse Width Modulation (N=CC\_NUM)**



**49.6.2.5.8 Output Polarity**

The polarity (WAVE.POLx) is available in all waveform output generation. In single-slope and dual-slope PWM operation, it is possible to invert the pulse edge alignment individually on start or end of a PWM cycle for each compare channels. The table below shows the waveform output set/clear conditions, depending on the settings of timer/counter, direction, and polarity.

**Table 49-3. Waveform Generation Set/Clear Conditions**

Waveform Generation Operation	DIR	POLx	Waveform Generation Output Update	
			Set	Clear
Single-Slope PWM	0	0	Timer/counter matches TOP	Timer/counter matches CCx
		1	Timer/counter matches CC	Timer/counter matches TOP
	1	0	Timer/counter matches CC	Timer/counter matches ZERO
		1	Timer/counter matches ZERO	Timer/counter matches CC
Dual-Slope PWM	x	0	Timer/counter matches CC when counting up	Timer/counter matches CC when counting down
		1	Timer/counter matches CC when counting down	Timer/counter matches CC when counting up

In Normal and Match Frequency, the WAVE.POLx value represents the initial state of the waveform output.

### 49.6.2.6 Double Buffering

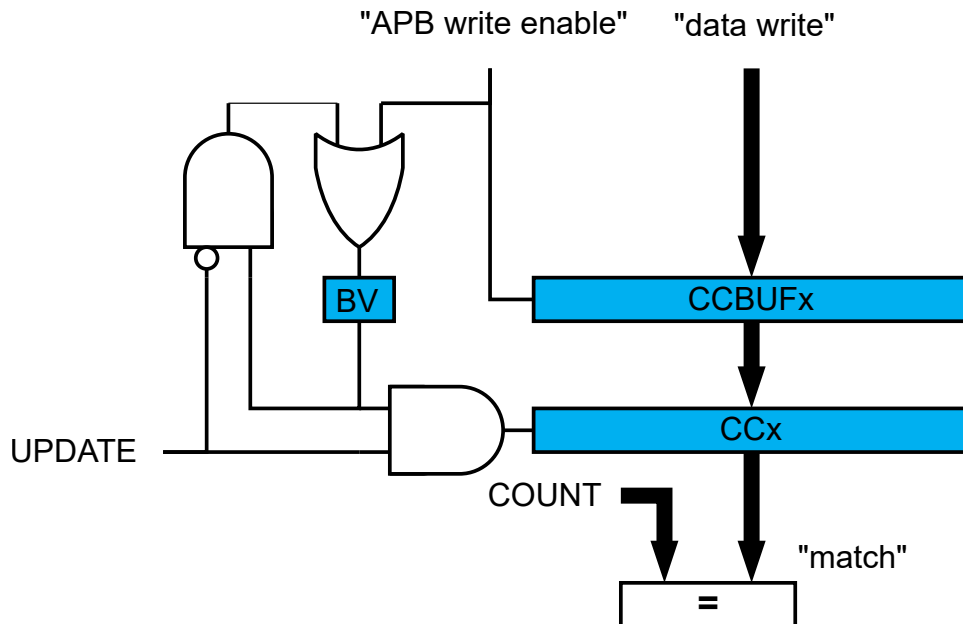
The Pattern (PATT), Period (PER) and Compare Channels (CCx) registers are all double buffered. Each buffer register has a buffer valid (PATTBUFV, PERBUFV and CCBUFVx) bit in the STATUS register, which indicates that the Buffer register contains a valid value that can be copied into the corresponding register. As long as the respective Buffer Valid Status flag (PATTBUFV, PERBUFV or CCBUFVx) are set to '1', the related SYNCBUSY bits are set (SYNCBUSY.PATT, SYNCBUSY.PER or SYNCBUSY.CCx), a write to the respective PATT/PATTBUF, PER/PERBUF or CCx/CCBUFx registers will generate a PAC error, and read access to the respective PATT, PER or CCx register is invalid.

When the Buffer Valid Flag bit in the STATUS register is '1' and the Lock Update bit in the CTRLB register is set to '0', (writing CTRLBCLR.LUPD to '1'), double buffering is enabled: the data from buffer registers will be copied into the corresponding register under hardware UPDATE conditions, then the Buffer Valid flags bit in the STATUS register are automatically cleared by hardware.

**Note:** Software update command (CTRLBSET.CMD=0x3) act independently of LUPD value.

A compare register is double buffered as in the following figure.

**Figure 49-9. Compare Channel Double Buffering**



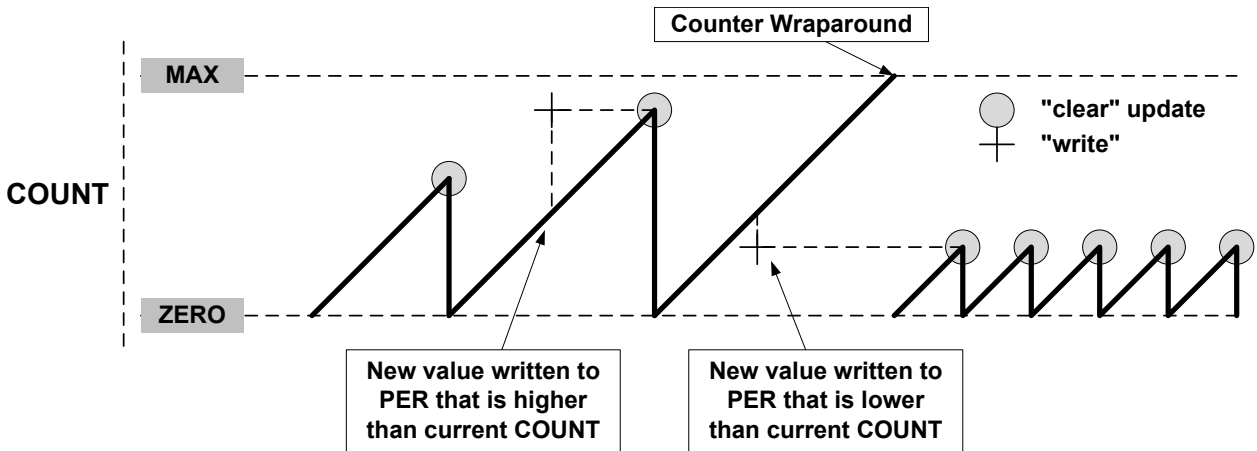
Both the registers (PATT/PER/CCx) and corresponding Buffer registers (PATTBUF/PERBUF/CCBUFx) are available in the I/O register map, and the double buffering feature is not mandatory. The double buffering is disabled by writing a '1' to CTRLSET.LUPD.

**Note:** In NFRQ, MFRQ or PWM Down-Counting Counter mode (CTRLBSET.DIR=1), when double buffering is enabled (CTRLBCLR.LUPD=1), PERBUF register is continuously copied into the PER independently of update conditions.

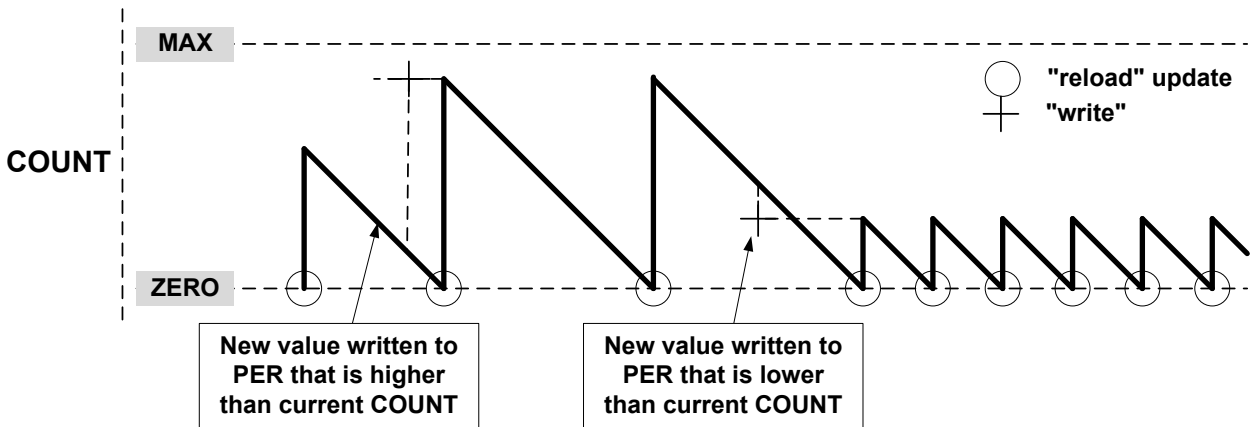
### Changing the Period

The counter period can be changed by writing a new Top value to the Period register (PER or CC0, depending on the Waveform Generation mode), any period update on registers (PER or CCx) is effective after the synchronization delay, whatever double buffering enabling is.

**Figure 49-10. Unbuffered Single-Slope Up-Counting Operation**

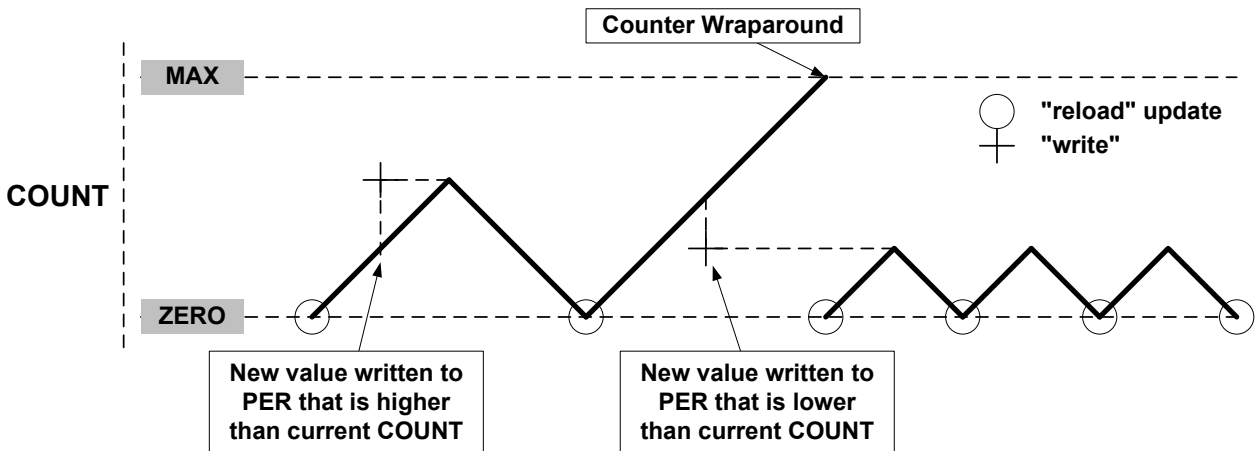


**Figure 49-11. Unbuffered Single-Slope Down-Counting Operation**



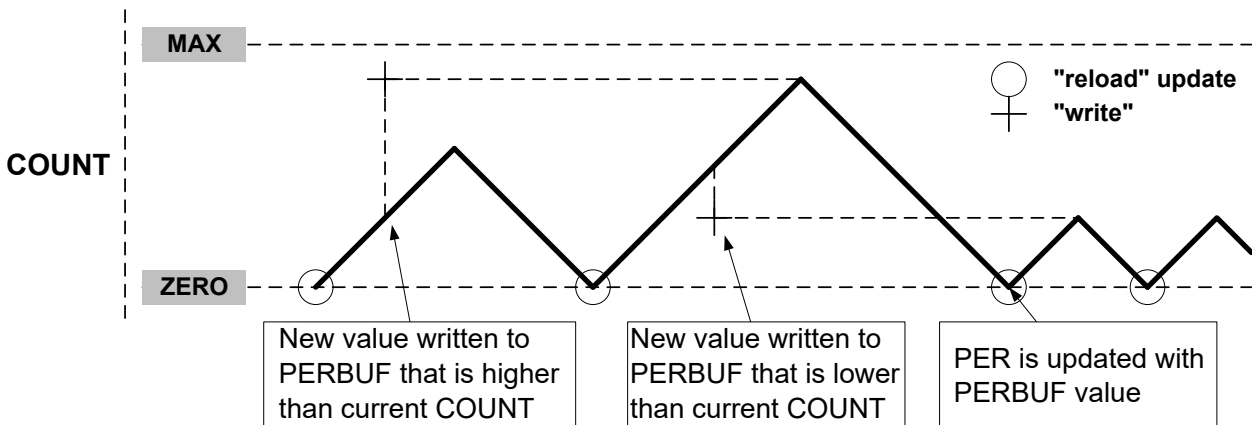
A counter wraparound can occur in any operation mode when up-counting without buffering, see [Figure 49-10](#). COUNT and TOP are continuously compared, so when a new value that is lower than the current COUNT is written to TOP, COUNT will wrap before a compare match.

**Figure 49-12. Unbuffered Dual-Slope Operation**



When double buffering is used, the buffer can be written at any time and the counter will still maintain correct operation. The period register is always updated on the update condition, as shown in [Figure 49-13](#). This prevents wraparound and the generation of odd waveforms.

**Figure 49-13. Changing the Period Using Buffering**



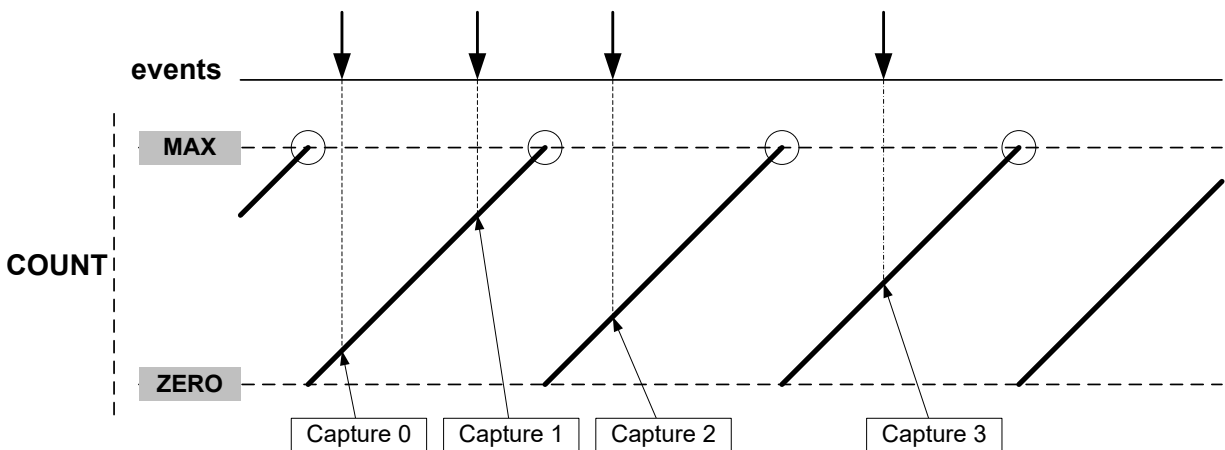
**49.6.2.7 Capture Operations**

To enable and use capture operations, the Match or Capture Channel x Event Input Enable bit in the Event Control register (EVCTRL.MCEIx) must be written to '1'. The capture channels to be used must also be enabled in the Capture Channel x Enable bit in the Control A register (CTRLA.CPTENx) before capturing can be performed.

**Event Capture Action**

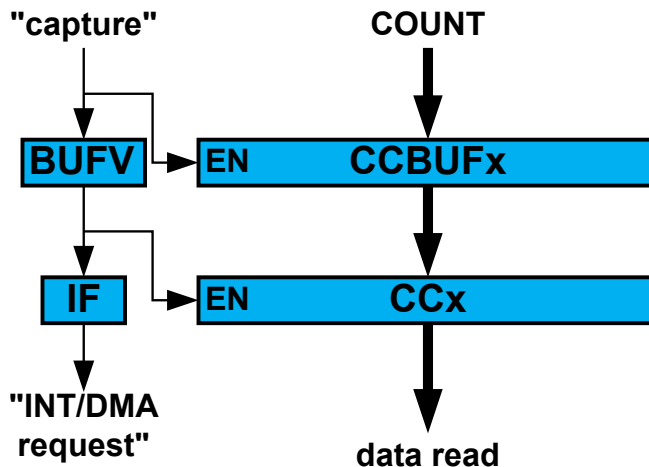
The compare/capture channels can be used as input capture channels to capture events from the Event System, and give them a timestamp. The following figure shows four capture events for one capture channel. Event system channels must be configured to operate in asynchronous mode when used for capture operations.

**Figure 49-14. Input Capture Timing**



For input capture, the Buffer register and the corresponding CCx act like a FIFO. When CCx is empty or read, any content in CCBUFx is transferred to CCx. The Buffer Valid flag is passed to set the CCx Interrupt flag (IF) and generate the optional interrupt, event, or DMA request. The CCBUFx register value cannot be read, all captured data must be read from the CCx register.

**Figure 49-15. Capture Double Buffering**



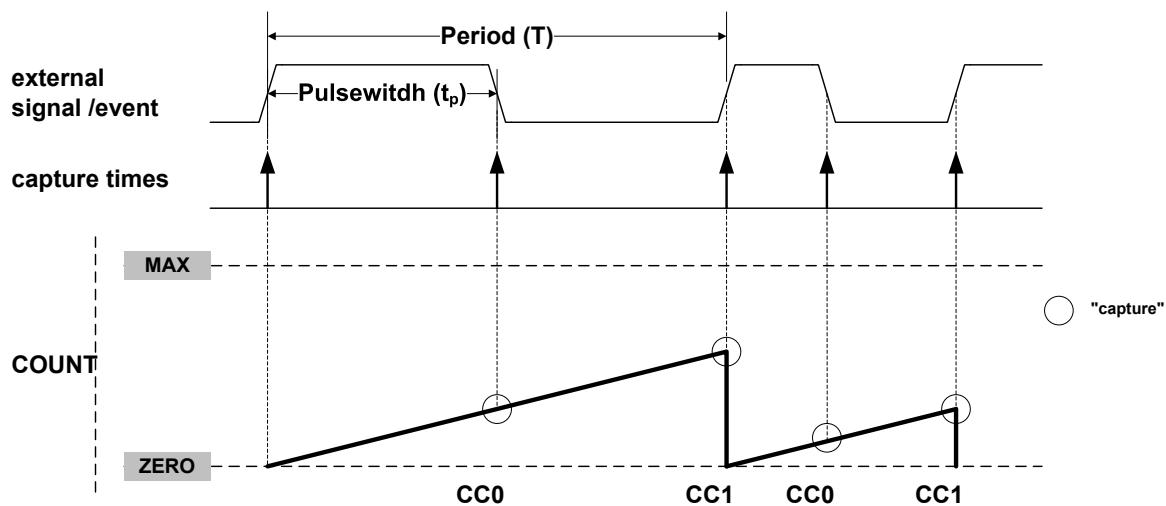
The TCC can detect capture overflow of the input capture channels. When a new capture event is detected while the Capture Buffer Valid flag (STATUS.CCBUFV) is still set, the new timestamp will not be stored and INTFLAG.ERR will be set.

**Period and Pulse-Width (PPW) Capture Action**

The TCC can perform two input captures and restart the counter on one of the edges. This enables the TCC to measure the pulse-width and period and to characterize the frequency  $f$  and  $dutyCycle$  of an input signal, as shown below:

$$f = \frac{1}{T} \quad , \quad dutyCycle = \frac{t_p}{T}$$

**Figure 49-16. PWP Capture**



Selecting PWP or PPW in the Timer/Counter Event Input 1 Action bit group in the Event Control register (EVCTRL.EVACT1) enables the TCC to perform one capture action on the rising edge and the other one on the falling edge. When using PPW event action, period  $T$  will be captured into CC0 and the pulse-width  $t_p$  into CC1. The PWP (Pulse-width and Period) event action offers the same functionality, but  $T$  will be captured into CC1 and  $t_p$  into CC0.

The Timer/Counter Event x Invert Enable bit in Event Control register (EVCTRL.TCEINVx) is used for event source x to select whether the wraparound should occur on the rising edge or the falling edge. If EVCTRL.TCEINVx=1, the wraparound will happen on the falling edge.



The corresponding capture is done only if the channel is enabled in Capture mode (CTRLA.CPTENx=1). If not, the capture action will be ignored and the channel will be enabled in compare mode of operation. When only one of these channel is required, the other channel can be used for other purposes.

The TCC can detect capture overflow of the input capture channels. When a new capture event is detected while the INTFLAG.MCx is still set, the new timestamp will not be stored and INTFLAG.ERR will be set.

**Note:** When up-counting (CTRLBSET.DIR=0), counter values lower than 1 cannot be captured in Capture Minimum mode (FCTRLn.CAPTURE=CAPTMIN). To capture the full range including value 0, the TCC must be configured in Down-counting mode (CTRLBSET.DIR=0).

**Note:** In dual-slope PWM operation, and when TOP is lower than MAX/2, the CCx MSB captures the CTRLB.DIR state to identify the ramp on which the capture has been done. For rising ramps CCx[MSB] is zero, for falling ramps CCx[MSB]=1.

### 49.6.3 Additional Features

#### 49.6.3.1 One-Shot Operation

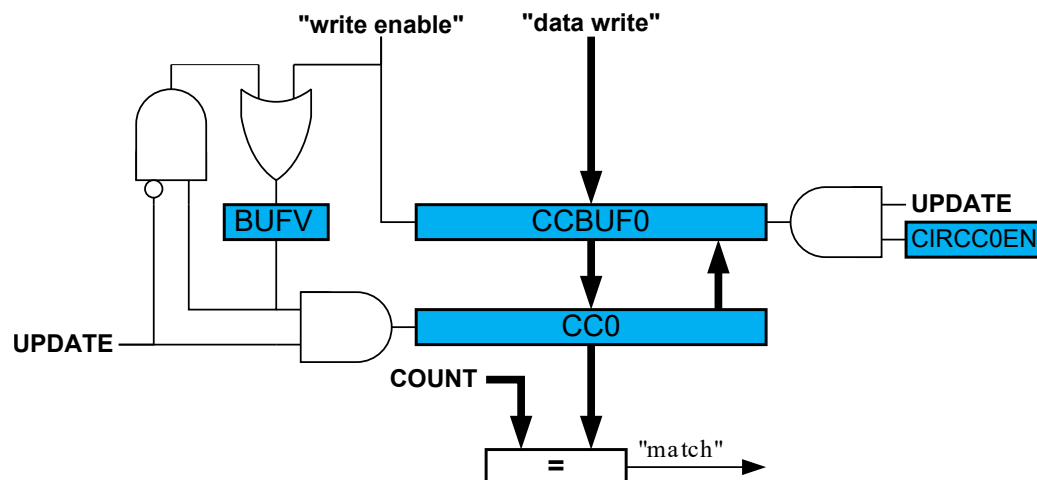
When one-shot is enabled, the counter automatically stops on the next Counter Overflow or Underflow condition. When the counter is stopped, the Stop bit in the Status register (STATUS.STOP) is set and the waveform outputs are set to the value defined by DRVCTRL.NREx and DRVCTRL.NRVx.

One-shot operation can be enabled by writing a '1' to the One-Shot bit in the Control B Set register (CTRLBSET.ONESHOT) and disabled by writing a '1' to CTRLBCLR.ONESHOT. When enabled, the TCC will count until an overflow or underflow occurs and stop counting. The one-shot operation can be restarted by a re-trigger software command, a re-trigger event or a start event. When the counter restarts its operation, STATUS.STOP is automatically cleared.

#### 49.6.3.2 Circular Buffer

The Period register (PER) and the Compare Channels register (CC0 to CC5) support circular buffer operation. When circular buffer operation is enabled, the PER or CCx values are copied into the corresponding buffer registers at each update condition. Circular buffering is dedicated to RAMP2, RAMP2A, and DSBOTH operations.

**Figure 49-17. Circular Buffer on Channel 0**



#### 49.6.3.3 Dithering Operation

The TCC supports dithering on Pulse-width or Period on a 16, 32 or 64 PWM cycles frame.

# SAM D5x/E5x Family Data Sheet

## TCC – Timer/Counter for Control Applications

Dithering consists in adding some extra clocks cycles in a frame of several PWM cycles, and can improve the accuracy of the *average* output pulse width and period. The extra clock cycles are added on some of the compare match signals, one at a time, through a "blue noise" process that minimizes the flickering on the resulting dither patterns.

Dithering is enabled by writing the corresponding configuration in the Enhanced Resolution bits in CTRLA register (CTRLA.RESOLUTION):

- DITH4 enable dithering every 16 PWM frames
- DITH5 enable dithering every 32 PWM frames
- DITH6 enable dithering every 64 PWM frames

The DITHERCY bits of COUNT, PER and CCx define the number of extra cycles to add into the frame (DITHERCY bits from the respective COUNT, PER or CCx registers). The remaining bits of COUNT, PER, CCx define the compare value itself.

The pseudo code, giving the extra cycles insertion regarding the cycle is:

```
int extra_cycle(resolution, dithercy, cycle){
    int MASK;
    int value
    switch (resolution){
        DITH4: MASK = 0x0f;
        DITH5: MASK = 0x1f;
        DITH6: MASK = 0x3f;
    }
    value = cycle * dithercy;
    if ((MASK & value) + dithercy) > MASK)
        return 1;
    return 0;
}
```

### Dithering on Period

Writing DITHERCY in PER will lead to an average PWM period configured by the following formulas.

DITH4 mode:

$$PwmPeriod = \left( \frac{DITHERCY}{16} + PER \right) \left( \frac{1}{f_{GCLK\_TCC}} \right)$$

**Note:** If DITH4 mode is enabled, the last 4 significant bits from PER/CCx or COUNT register correspond to the DITHERCY value, rest of the bits corresponds to PER/CCx or COUNT value.

DITH5 mode:

$$PwmPeriod = \left( \frac{DITHERCY}{32} + PER \right) \left( \frac{1}{f_{GCLK\_TCC}} \right)$$

DITH6 mode:

$$PwmPeriod = \left( \frac{DITHERCY}{64} + PER \right) \left( \frac{1}{f_{GCLK\_TCC}} \right)$$

### Dithering on Pulse-Width

Writing DITHERCY in CCx will lead to an average PWM pulse width configured by the following formula.

DITH4 mode:

$$PwmPulseWidth = \left( \frac{DITHERCY}{16} + CCx \right) \left( \frac{1}{f_{GCLK\_TCC}} \right)$$

DITH5 mode:

$$PwmPulseWidth = \left( \frac{DITHERCY}{32} + CCx \right) \left( \frac{1}{f_{GCLK\_TCC}} \right)$$

DITH6 mode:

$$PwmPulseWidth = \left( \frac{DITHERCY}{64} + CCx \right) \left( \frac{1}{f_{GCLK\_TCC}} \right)$$

**Note:** The PWM period will remain static in this case.

### 49.6.3.4 Ramp Operations

Three ramp operation modes are supported. All of them require the timer/counter running in single-slope PWM generation. The Ramp mode is selected by writing to the Ramp Mode bits in the Waveform Control register (WAVE.RAMP).

#### RAMP1 Operation

This is the default PWM operation, described in [Single-Slope PWM Generation](#).

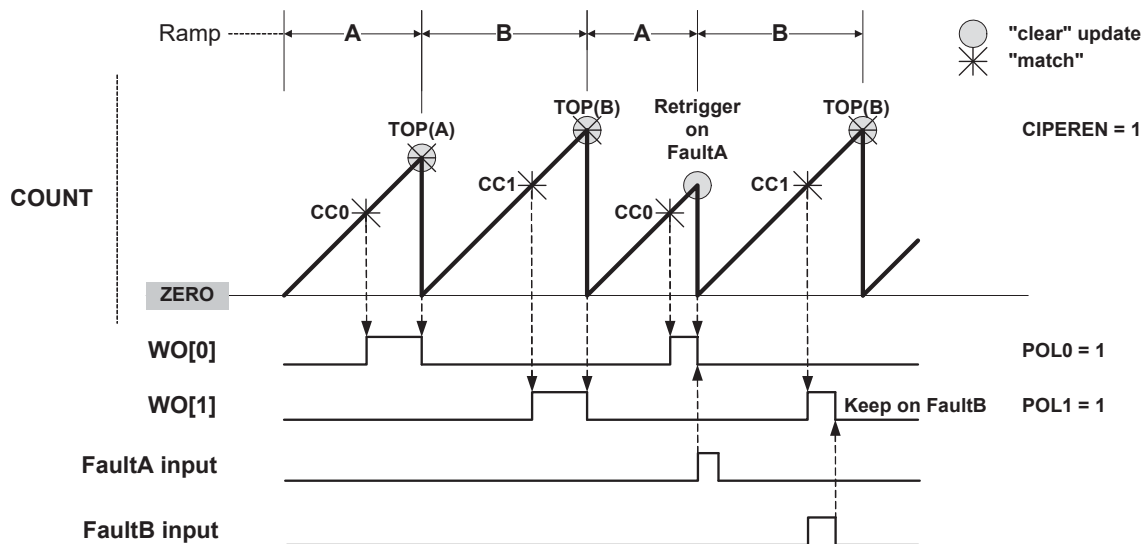
#### RAMP2 Operation

These operation modes are dedicated for power factor correction (PFC), Half-Bridge and Push-Pull SMPS topologies, where two consecutive timer/counter cycles are interleaved, see [Figure 49-18](#). In cycle A, odd channel output is disabled, and in cycle B, even channel output is disabled. The ramp index changes after each update, but can be software modified using the Ramp index command bits in Control B Set register (CTRLBSET.IDXCMD).

#### Standard RAMP2 (RAMP2) Operation

Ramp A and B periods are controlled by the PER register value. The PER value can be different on each ramp by the Circular Period buffer option in the Wave register (WAVE.CIPEREN=1). This mode uses a two-channel TCC to generate two output signals, or one output signal with another CC channel enabled in Capture mode.

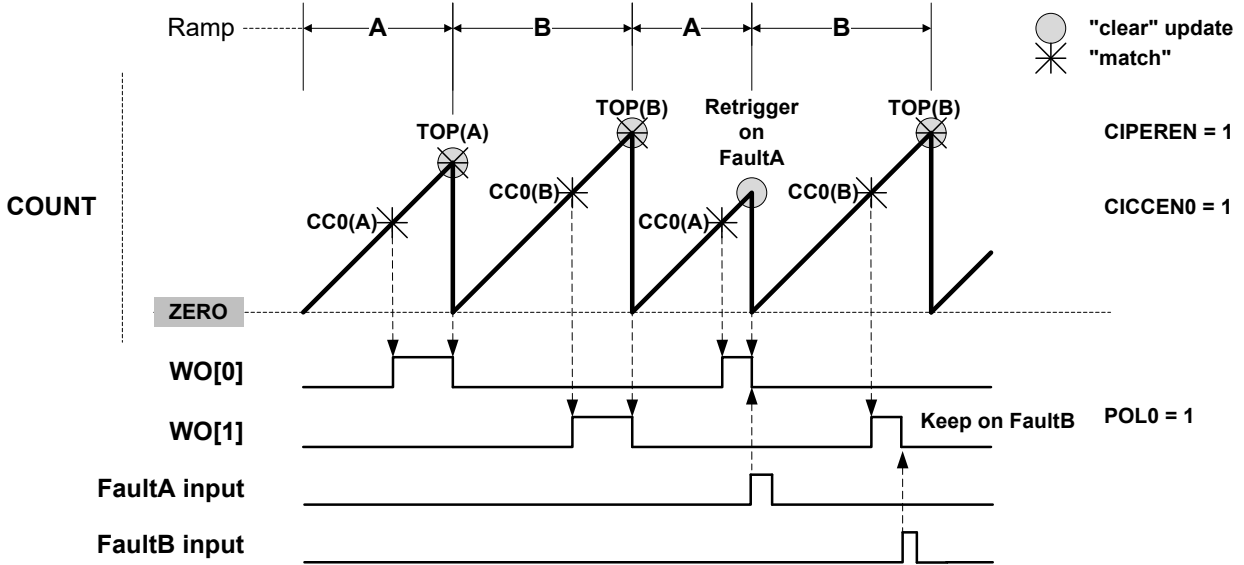
**Figure 49-18. RAMP2 Standard Operation**



### Alternate RAMP2 (RAMP2A) Operation

Alternate RAMP2 operation is similar to RAMP2, but CC0 controls both WO[0] and WO[1] waveforms when the corresponding circular buffer option is enabled (CIPEREN=1). The waveform polarity is the same on both outputs. Channel 1 can be used in capture mode.

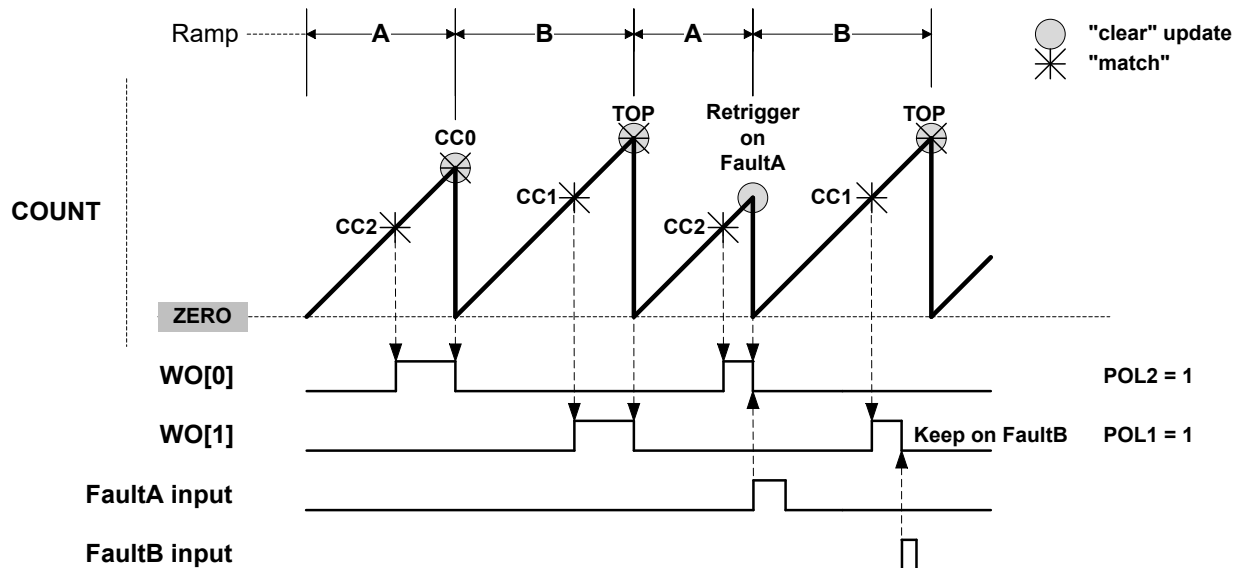
**Figure 49-19. RAMP2 Alternate Operation**



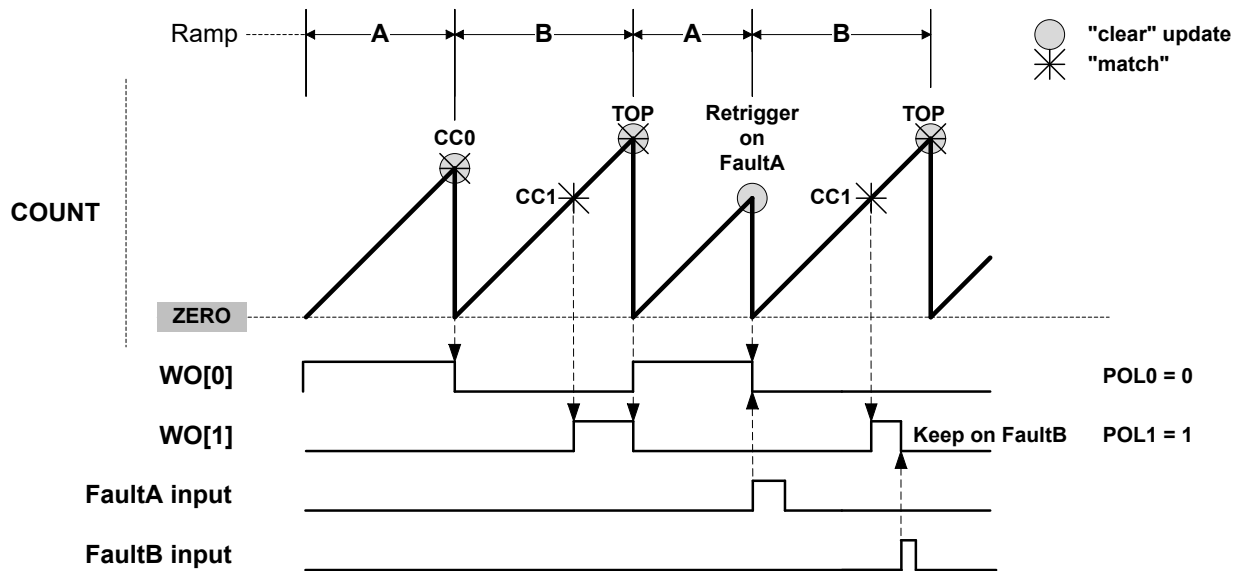
### Critical RAMP2 (RAMP2C) Operation

Critical RAMP2 operation provides a way to cover RAMP2 operation requirements without the update constraint associated with the use of circular buffers. In this mode, CC0 is controlling the period of ramp A and PER is controlling the period of ramp B. When using more than two channels, WO[0] output is controlled by CC2 (HIGH) and CC0 (LOW). On TCC with 2 channels, a pulse on WO[0] will last the entire period of ramp A, if WAVE.POL0=0.

**Figure 49-20. RAMP2 Critical Operation With More Than 2 Channels**



**Figure 49-21. RAMP2 Critical Operation With 2 Channels**



### 49.6.3.5 Recoverable Faults

Recoverable faults can restart or halt the timer/counter. Two faults, called Fault A and Fault B, can trigger recoverable fault actions on the compare channels CC0 and CC1 of the TCC. The compare channels' outputs can be clamped to inactive state either as long as the fault condition is present, or from the first valid fault condition detection on until the end of the timer/counter cycle.

#### Fault Inputs

The first two channel input events (TCCxMC0 and TCCxMC1) can be used as Fault A and Fault B inputs, respectively. Event system channels connected to these fault inputs must be configured as asynchronous. The TCC must work in a PWM mode.

#### Fault Filtering

There are three filters available for each input Fault A and Fault B. They are configured by the corresponding Recoverable Fault n Configuration registers (FCTRLA and FCTRLB). The three filters can either be used independently or in any combination.

**Input Filtering** By default, the event detection is asynchronous. When the event occurs, the fault system will immediately and asynchronously perform the selected fault action on the compare channel output, also in device power modes where the clock is not available. To avoid false fault detection on external events (e.g. due to a glitch on an I/O port) a digital filter can be enabled and configured by the Fault B Filter Value bits in the Fault n Configuration registers (FCTRLn.FILTERVAL). If the event width is less than FILTERVAL (in clock cycles), the event will be discarded. A valid event will be delayed by FILTERVAL clock cycles.

**Fault Blanking** This ignores any fault input for a certain time just after a selected waveform output edge. This can be used to prevent false fault triggering due to signal bouncing, as shown in the figure below. Blanking can be enabled by writing an edge triggering configuration to the Fault n Blanking Mode bits in the Recoverable Fault n Configuration register (FCTRLn.BLANK). The desired duration of the blanking must be written to the Fault n Blanking Time bits (FCTRLn.BLANKVAL). The blanking time  $t_b$  is calculated by

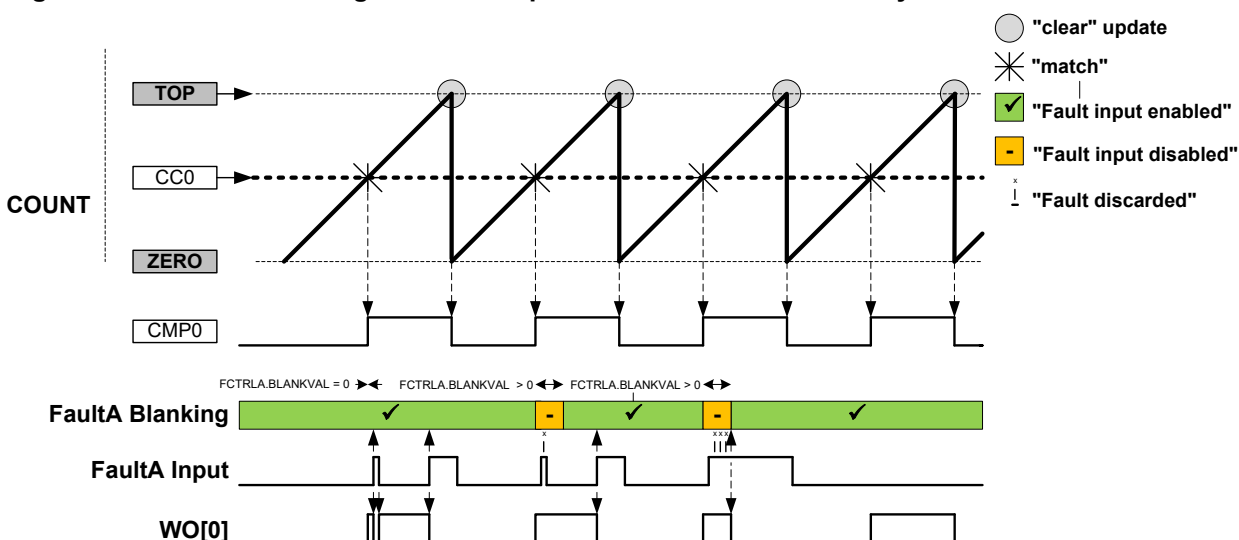
$$t_b = \frac{1 + \text{BLANKVAL}}{f_{\text{GCLK\_TCCx\_PRESC}}}$$

Here,  $f_{\text{GCLK\_TCCx\_PRESC}}$  is the frequency of the prescaled peripheral clock frequency  $f_{\text{GCLK\_TCCx}}$ .

The prescaler is enabled by writing '1' to the Fault n Blanking Prescaler bit (FCTRLn.BLANKPRESC). When disabled,  $f_{\text{GCLK\_TCCx\_PRESC}} = f_{\text{GCLK\_TCCx}}$ . When enabled,  $f_{\text{GCLK\_TCCx\_PRESC}} = f_{\text{GCLK\_TCCx}}/64$ .

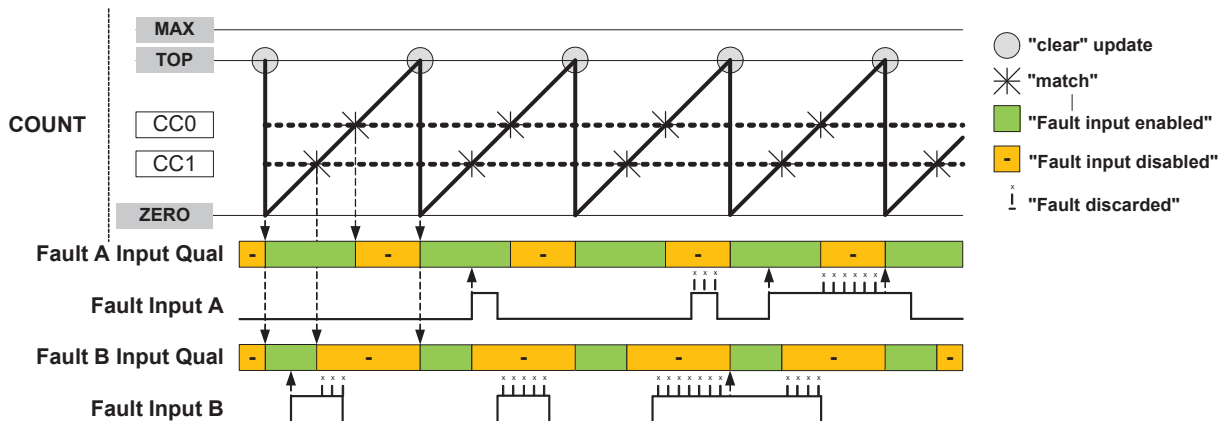
The maximum blanking time (FCTRLn.BLANKVAL=255) at  $f_{\text{GCLK\_TCCx}}=96\text{MHz}$  is  $2.67\mu\text{s}$  (no prescaler) or  $170\mu\text{s}$  (prescaling). For  $f_{\text{GCLK\_TCCx}}=1\text{MHz}$ , the maximum blanking time is either  $170\mu\text{s}$  (no prescaling) or  $10.9\text{ms}$  (prescaling enabled).

**Figure 49-22. Fault Blanking in RAMP1 Operation with Inverted Polarity**

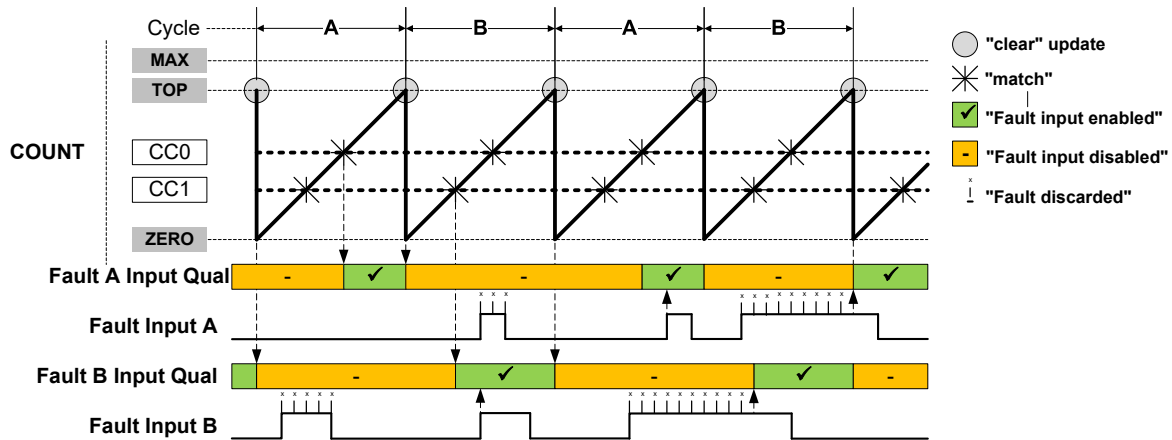


**Fault Qualification** This is enabled by writing a '1' to the Fault n Qualification bit in the Recoverable Fault n Configuration register (FCTRLn.QUAL). When the recoverable fault qualification is enabled (FCTRLn.QUAL=1), the fault input is disabled all the time the corresponding channel output has an inactive level, as shown in the figures below.

**Figure 49-23. Fault Qualification in RAMP1 Operation**



**Figure 49-24. Fault Qualification in RAMP2 Operation with Inverted Polarity**

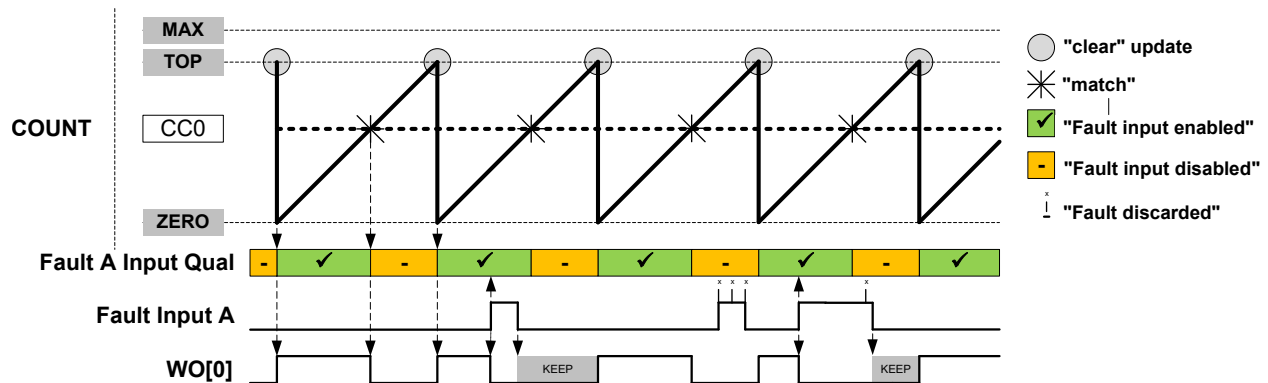


### Fault Actions

Different fault actions can be configured individually for Fault A and Fault B. Most fault actions are not mutually exclusive; hence two or more actions can be enabled at the same time to achieve a result that is a combination of fault actions.

**Keep Action** This is enabled by writing the Fault n Keeper bit in the Recoverable Fault n Configuration register (FCTRLn.KEEP) to '1'. When enabled, the corresponding channel output will be clamped to zero as long as the fault condition is present. The clamp will be released on the start of the first cycle after the fault condition is no longer present, see next Figure.

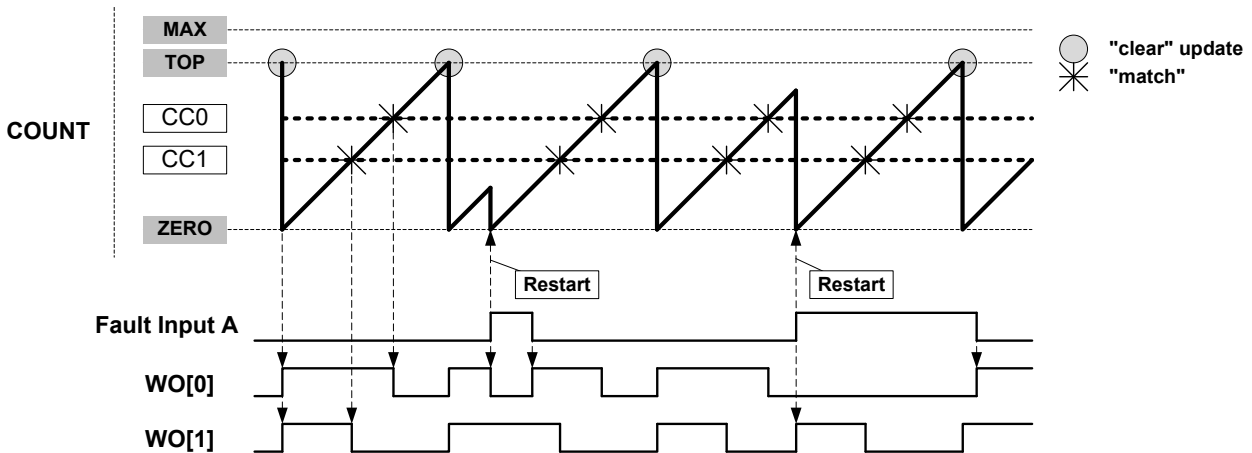
**Figure 49-25. Waveform Generation with Fault Qualification and Keep Action**



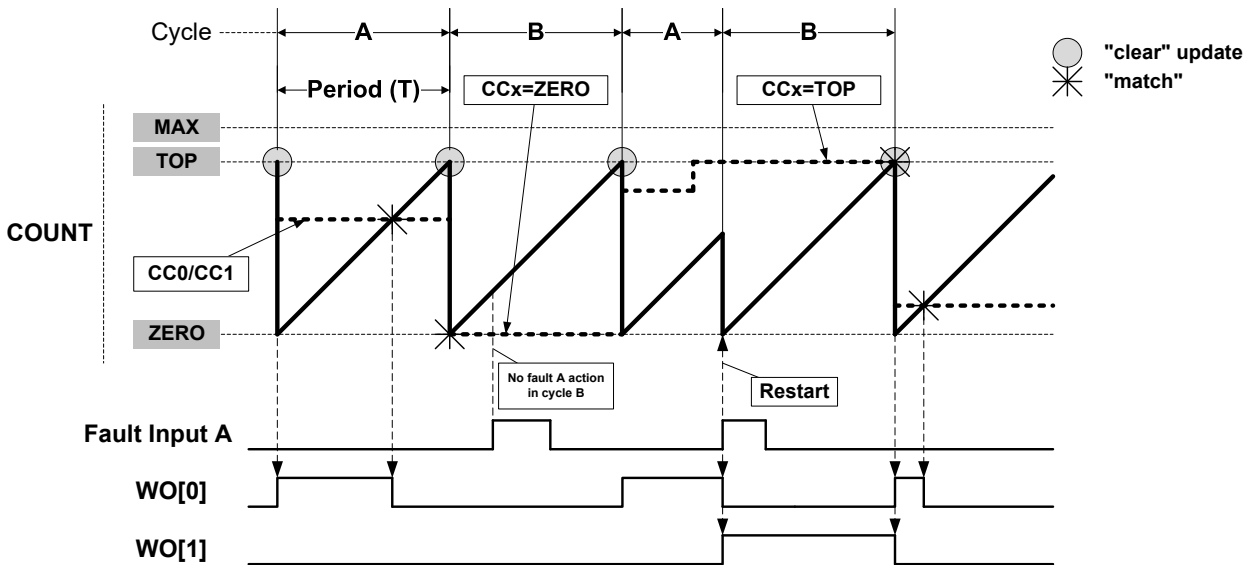
**Restart Action** This is enabled by writing the Fault n Restart bit in Recoverable Fault n Configuration register (FCTRLn.RESTART) to '1'. When enabled, the timer/counter will be restarted as soon as the corresponding fault condition is present. The ongoing cycle is stopped and the timer/counter starts a new cycle, see [Figure 49-26](#). In Ramp 1 mode, when the new cycle starts, the compare outputs will be clamped to inactive level as long as the fault condition is present.

**Note:** For RAMP2 operation, when a new timer/counter cycle starts the cycle index will change automatically, see [Figure 49-27](#). Fault A and Fault B are qualified only during the cycle A and cycle B respectively: Fault A is disabled during cycle B, and Fault B is disabled during cycle A.

**Figure 49-26. Waveform Generation in RAMP1 mode with Restart Action**



**Figure 49-27. Waveform Generation in RAMP2 mode with Restart Action**



**Capture Action** Several capture actions can be selected by writing the Fault n Capture Action bits in the Fault n Control register (FCTRLn.CAPTURE). When one of the capture operations is selected, the counter value is captured when the fault occurs. These capture operations are available:

- CAPT - the equivalent to a standard capture operation, for further details refer to [49.6.2.7 Capture Operations](#)
- CAPTMIN - gets the minimum time stamped value: on each new local minimum captured value, an event or interrupt is issued.
- CAPTMAX - gets the maximum time stamped value: on each new local maximum captured value, an event or interrupt (IT) is issued, see [Figure 49-28](#).
- LOCMIN - notifies by event or interrupt when a local minimum captured value is detected.
- LOCMAX - notifies by event or interrupt when a local maximum captured value is detected.
- DERIV0 - notifies by event or interrupt when a local extreme captured value is detected, see [Figure 49-29](#).



*CCx Content:*

In CAPTMIN and CAPTMAX operations, CCx keeps the respective extremum captured values, see [Figure 49-28](#). In LOCMIN, LOCMAX or DERIV0 operation, CCx follows the counter value at fault time, see [Figure 49-29](#).

Before enabling CAPTMIN or CAPTMAX mode of capture, the user must initialize the corresponding CCx register value to a value different from zero (for CAPTMIN) top (for CAPTMAX). If the CCx register initial value is zero (for CAPTMIN) top (for CAPTMAX), no captures will be performed using the corresponding channel.

*MCx Behaviour:*

In LOCMIN and LOCMAX operation, capture is performed on each capture event. The MCx interrupt flag is set only when the captured value is above or equal (for LOCMIN) or below or equal (for LOCMAX) to the previous captured value. So interrupt flag is set when a new relative local Minimum (for CAPTMIN) or Maximum (for CAPTMAX) value has been detected. DERIV0 is equivalent to an OR function of (LOCMIN, LOCMAX).

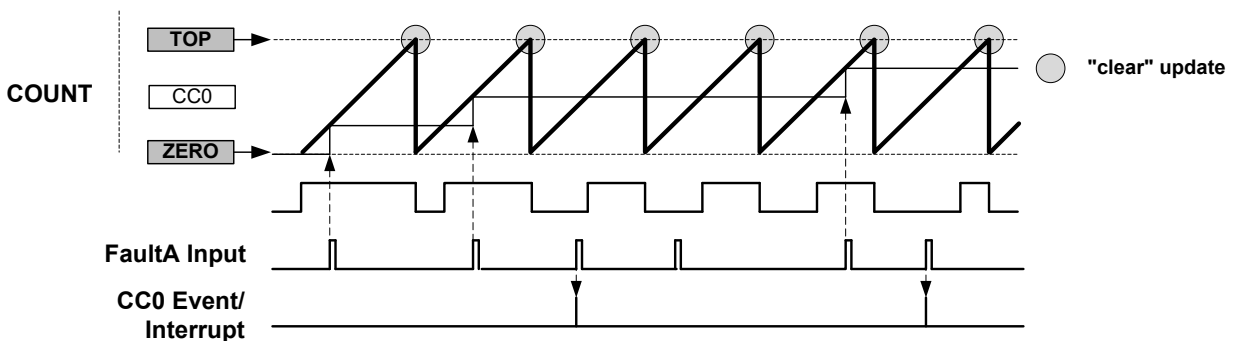
In CAPT operation, capture is performed on each capture event. The MCx interrupt flag is set on each new capture.

In CAPTMIN and CAPTMAX operation, capture is performed only when on capture event time, the counter value is lower (for CAPTMIN) or higher (for CAPMAX) than the last captured value. The MCx interrupt flag is set only when on capture event time, the counter value is higher or equal (for CAPTMIN) or lower or equal (for CAPTMAX) to the value captured on the previous event. So interrupt flag is set when a new absolute local Minimum (for CAPTMIN) or Maximum (for CAPTMAX) value has been detected.

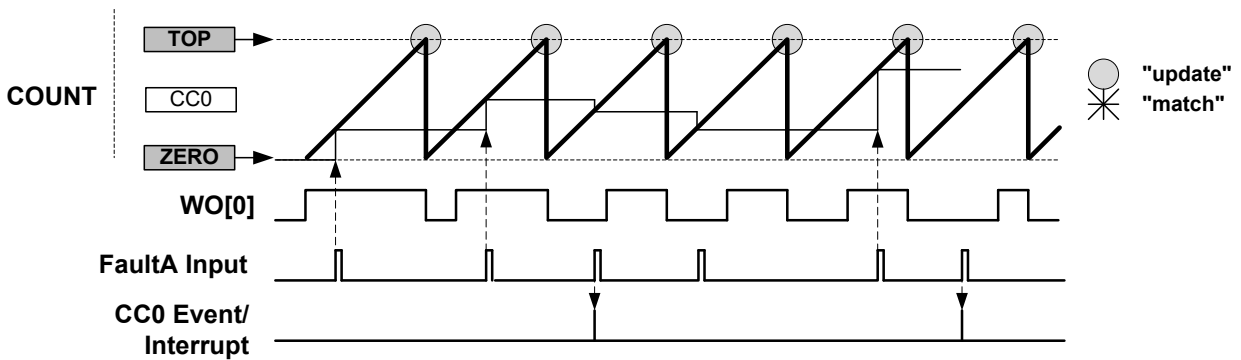
*Interrupt Generation*

In CAPT mode, an interrupt is generated on each filtered Fault n and each dedicated CCx channel capture counter value. In other modes, an interrupt is only generated on an extreme captured value.

**Figure 49-28. Capture Action “CAPTMAX”**



**Figure 49-29. Capture Action “DERIV0”**



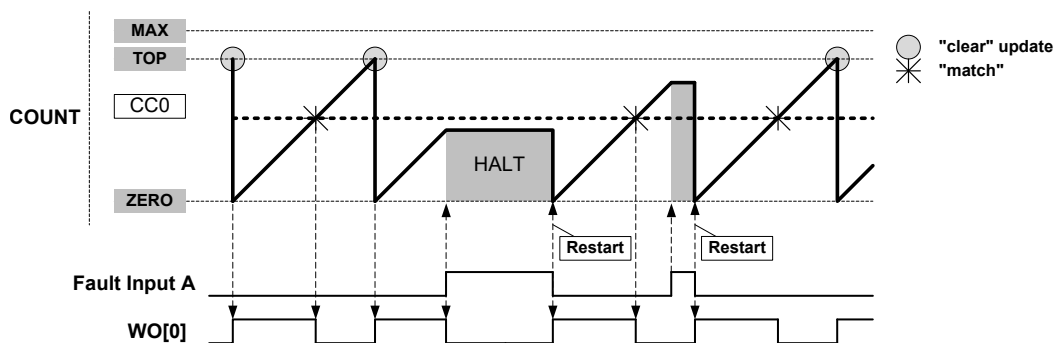
**Hardware Halt Action** This is configured by writing 0x1 to the Fault n Halt mode bits in the Recoverable Fault n Configuration register (FCTRLn.HALT). When enabled, the timer/counter is halted and the cycle is extended as long as the corresponding fault is present.

The next figure ('Waveform Generation with Halt and Restart Actions') shows an example where both restart action and hardware halt action are enabled for Fault A. The compare channel 0 output is clamped to inactive level as long as the timer/counter is halted. The timer/counter resumes the counting operation as soon as the fault condition is no longer present. As the restart action is enabled in this example, the timer/counter is restarted after the fault condition is no longer present.

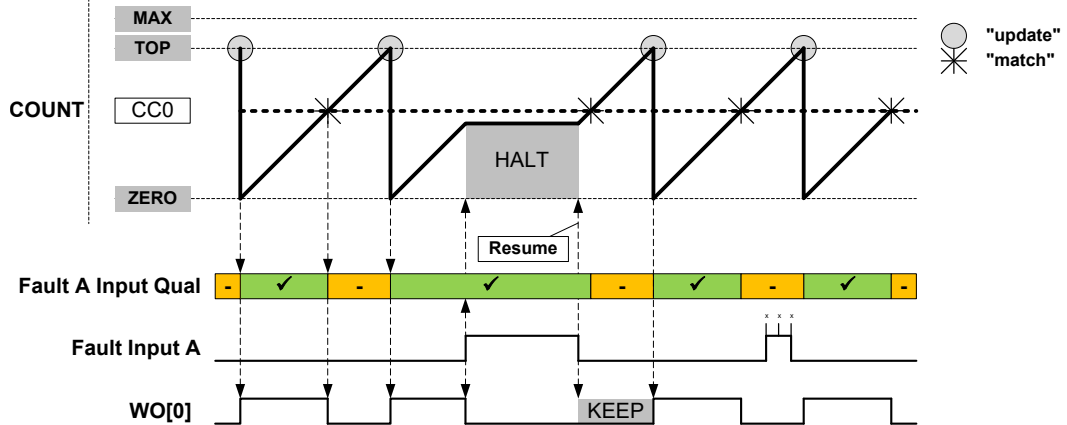
The figure after that ('Waveform Generation with Fault Qualification, Halt, and Restart Actions') shows a similar example, but with additionally enabled fault qualification. Here, counting is resumed after the fault condition is no longer present.

Note that in RAMP2 and RAMP2A operations, when a new timer/counter cycle starts, the cycle index will automatically change.

**Figure 49-30. Waveform Generation with Halt and Restart Actions**



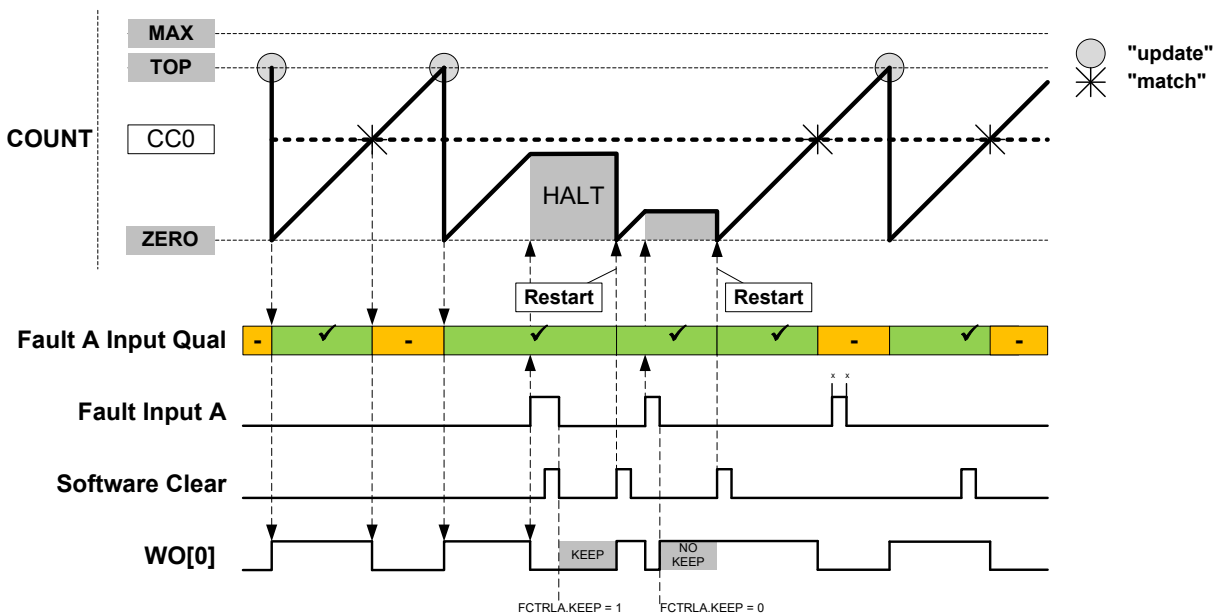
**Figure 49-31. Waveform Generation with Fault Qualification, Halt, and Restart Actions**



**Software Halt Action**

This is configured by writing 0x2 to the Fault n Halt mode bits in the Recoverable Fault n configuration register (FCTRLn.HALT). Software halt action is similar to hardware halt action, but in order to restart the timer/counter, the corresponding fault condition must not be present anymore, and the corresponding FAULT n bit in the STATUS register must be cleared by software.

**Figure 49-32. Waveform Generation with Software Halt, Fault Qualification, Keep and Restart Actions**



**49.6.3.6 Non-Recoverable Faults**

The non-recoverable fault action will force all the compare outputs to a pre-defined level programmed into the Driver Control register (DRVCTRL.NRE and DRVCTRL.NRV). The non-recoverable fault input (EV0 and EV1) actions are enabled in Event Control register (EVCTRL.EVACT0 and EVCTRL.EVACT1).

To avoid false fault detection on external events (e.g. a glitch on an I/O port) a digital filter can be enabled using Non-Recoverable Fault Input x Filter Value bits in the Driver Control register

(DRVCTRL.FILTERVALn). Therefore, the event detection is synchronous, and event action is delayed by the selected digital filter value clock cycles.

When the Fault Detection on Debug Break Detection bit in Debug Control register (DGBCTRL.FDDBD) is written to '1', a non-recoverable Debug Faults State and an interrupt (DFS) is generated when the system goes in debug operation.

In RAMP2, RAMP2A, or DSBOTH operation, when the Lock Update bit in the Control B register is set by writing CTRLBSET.LUPD=1 and the ramp index or counter direction changes, a non-recoverable Update Fault State and the respective interrupt (UFS) are generated.

### 49.6.3.7 Time-Stamp Capture

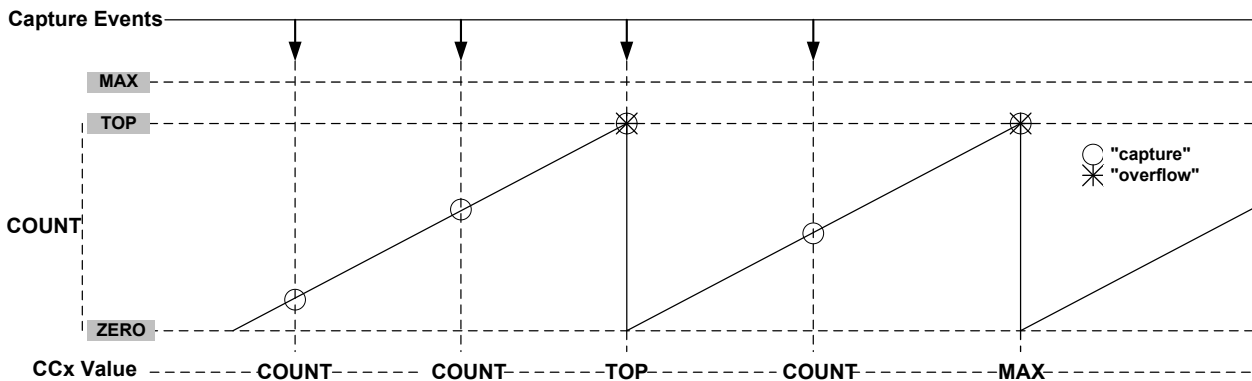
This feature is enabled when the Capture Time Stamp (STAMP) Event Action in Event Control register (EVCTRL.EVACT) is selected. The counter TOP value must be smaller than MAX.

When a capture event is detected, the COUNT value is copied into the corresponding Channel x Compare/Capture Value (CCx) register. In case of an overflow, the MAX value is copied into the corresponding CCx register.

When a valid captured value is present in the capture channel register, the corresponding Capture Channel x Interrupt Flag (INTFLAG.MCx) is set.

The timer/counter can detect capture overflow of the input capture channels: When a new capture event is detected while the Capture Channel interrupt flag (INTFLAG.MCx) is still set, the new time-stamp will not be stored and INTFLAG.ERR will be set.

**Figure 49-33. Time-Stamp**



### 49.6.3.8 Waveform Extension

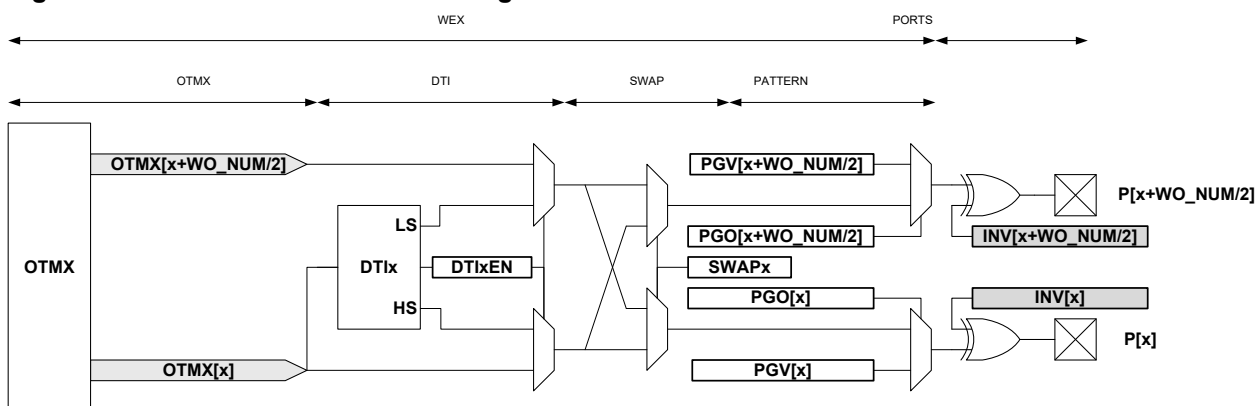
Figure 49-34 shows a schematic diagram of actions of the four optional units that follow the recoverable fault stage on a port pin pair: Output Matrix (OTMX), Dead-Time Insertion (DTI), SWAP and Pattern Generation. The DTI and SWAP units can be seen as a four port pair slices:

- Slice 0 DTI0 / SWAP0 acting on port pins (WO[0], WO[WO\_NUM/2 +0])
- Slice 1 DTI1 / SWAP1 acting on port pins (WO[1], WO[WO\_NUM/2 +1])

And generally:

- Slice n DTIx / SWAPx acting on port pins (WO[x], WO[WO\_NUM/2 +x])

**Figure 49-34. Waveform Extension Stage Details**



The **output matrix (OTMX)** unit distributes compare channels, according to the selectable configurations in the following table.

**Table 49-4. Output Matrix Channel Pin Routing Configuration**

Value	OTMX[7]	OTMX[6]	OTMX[5]	OTMX[4]	OTMX[3]	OTMX[2]	OTMX[1]	OTMX[0]
0x0	CC1	CC0	CC5	CC4	CC3	CC2	CC1	CC0
0x1	CC1	CC0	CC2	CC1	CC0	CC2	CC1	CC0
0x2	CC0	CC0	CC0	CC0	CC0	CC0	CC0	CC0
0x3	CC1	CC1	CC1	CC1	CC1	CC1	CC1	CC0

- Configuration 0x0 is the default configuration. The channel location is the default one and channels are distributed on outputs modulo the number of channels. Channel 0 is routed to the Output matrix output OTMX[0], and Channel 1 to OTMX[1]. If there are more outputs than channels, then channel 0 is duplicated to the Output matrix output OTMX[CC\_NUM], channel 1 to OTMX[CC\_NUM+1] and so on.
- Configuration 0x1 distributes the channels on output modulo half the number of channels. This assigns twice the number of output locations to the lower channels than the default configuration. This can be used, for example, to control the four transistors of a full bridge using only two compare channels. Using pattern generation, some of these four outputs can be overwritten by a constant level, enabling flexible drive of a full bridge in all quadrant configurations.
- Configuration 0x2 distributes compare channel 0 (CC0) to all port pins. With pattern generation, this configuration can control a stepper motor.
- Configuration 0x3 distributes the compare channel CC0 to the first output, and the channel CC1 to all other outputs. Together with pattern generation and the fault extension, this configuration can control up to seven LED strings, with a boost stage.

The table below is an example showing four compare channels on four outputs.

**Table 49-5. Four Compare Channels on Four Outputs**

Value	OTMX[3]	OTMX[2]	OTMX[1]	OTMX[0]
0x0	CC3	CC2	CC1	CC0
0x1	CC1	CC0	CC1	CC0

# SAM D5x/E5x Family Data Sheet

## TCC – Timer/Counter for Control Applications

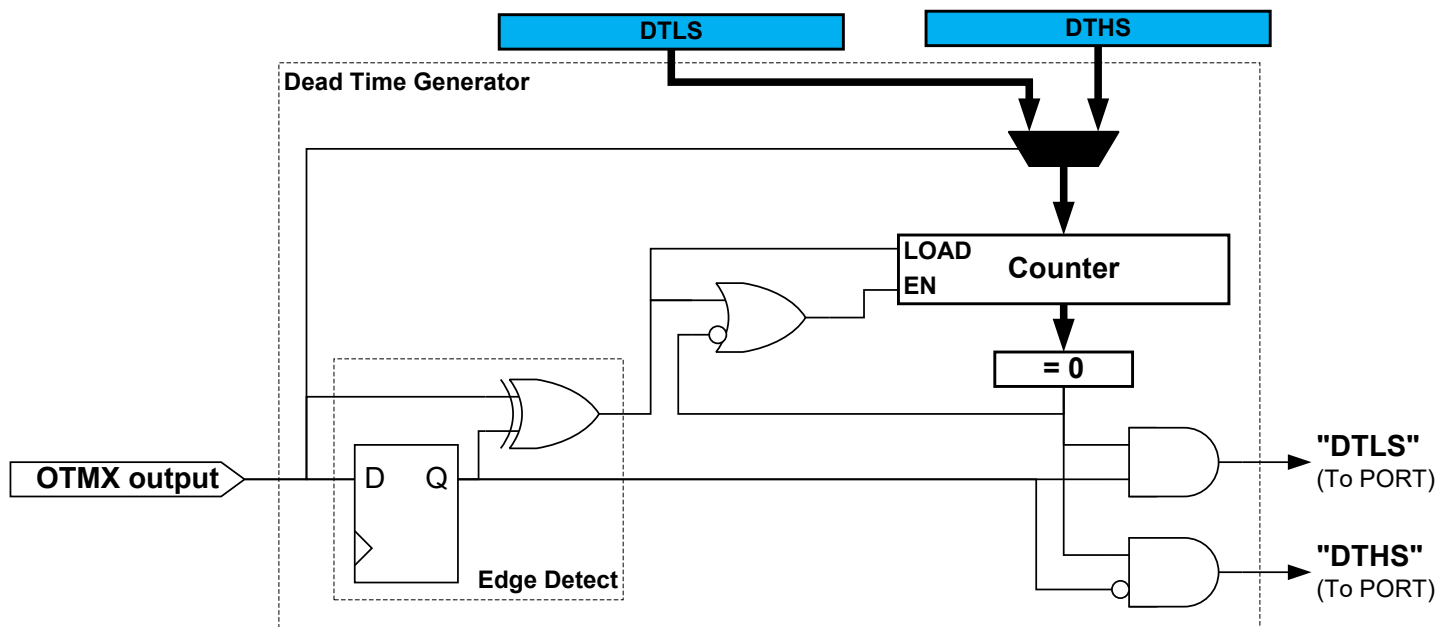
.....continued

Value	OTMX[3]	OTMX[2]	OTMX[1]	OTMX[0]
0x2	CC0	CC0	CC0	CC0
0x3	CC1	CC1	CC1	CC0

The **dead-time insertion (DTI)** unit generates OFF time with the non-inverted low side (LS) and inverted high side (HS) of the wave generator output forced at low level. This OFF time is called dead time. Dead-time insertion ensures that the LS and HS will never switch simultaneously.

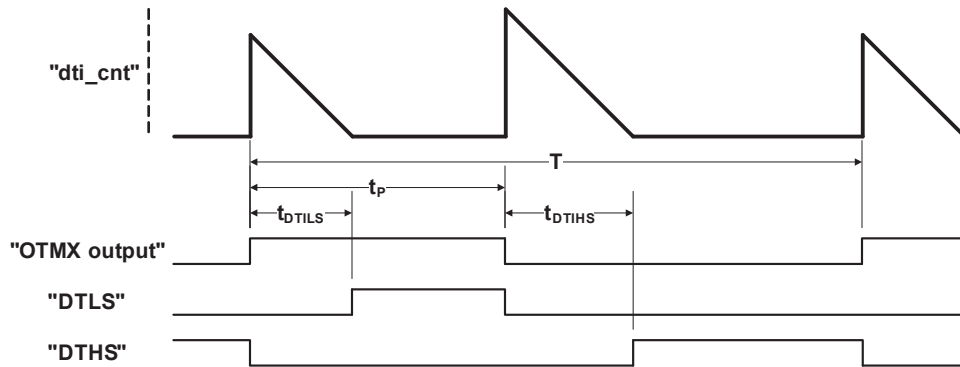
The DTI stage consists of four equal dead-time insertion generators; one for each of the first four compare channels. [Figure 49-35](#) shows the block diagram of one DTI generator. The four channels have a common register which controls the dead time, which is independent of high side and low side setting.

**Figure 49-35. Dead-Time Generator Block Diagram**



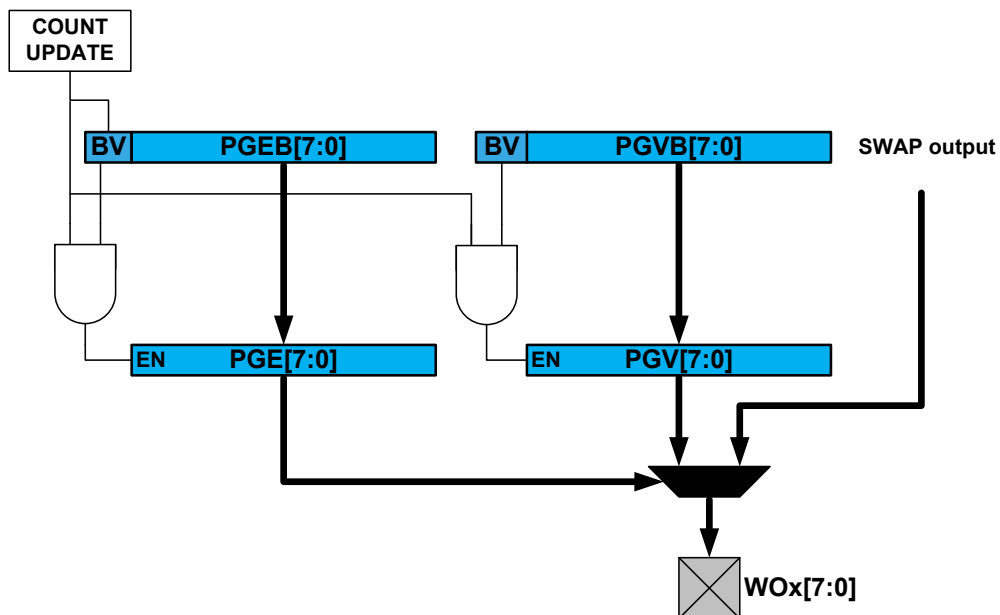
As shown in [Figure 49-36](#), the 8-bit dead-time counter is decremented by one for each peripheral clock cycle until it reaches zero. A non-zero counter value will force both the low side and high side outputs into their OFF state. When the output matrix (OTMX) output changes, the dead-time counter is reloaded according to the edge of the input. When the output changes from low to high (positive edge) it initiates a counter reload of the DTLS register. When the output changes from high to low (negative edge) it reloads the DTHS register.

**Figure 49-36. Dead-Time Generator Timing Diagram**



The **pattern generator unit** produces a synchronized bit pattern across the port pins it is connected to. The pattern generation features are primarily intended for handling the commutation sequence in brushless DC motors (BLDC), stepper motors, and full bridge control. See also [Figure 49-37](#).

**Figure 49-37. Pattern Generator Block Diagram**



As with other double-buffered timer/counter registers, the register update is synchronized to the UPDATE condition set by the timer/counter waveform generation operation. If synchronization is not required by the application, the software can simply access directly the PATT.PGE, PATT.PGV bits registers.

#### 49.6.4 Master/Slave Operation

Two or more TCC instances sharing the same GCLK\_TCC clock, can be linked to provide more synchronized CC channels. The operation is enabled by setting the Master Synchronization bit in Control A register (CTRLA.MSYNC) in the Slave instance. When the bit is set, the slave TCC instance will synchronize the CC channels to the Master counter.

#### Related Links

[49.8.1 CTRLA](#)

# SAM D5x/E5x Family Data Sheet

## TCC – Timer/Counter for Control Applications

### 49.6.5 DMA, Interrupts, and Events

**Table 49-6. Module Requests for TCC**

Condition	Interrupt request	Event output	Event input	DMA request	DMA request is cleared
Overflow / Underflow	Yes	Yes		Yes <sup>(1)</sup>	On DMA acknowledge
Channel Compare Match or Capture	Yes	Yes	Yes <sup>(2)</sup>	Yes <sup>(3)</sup>	For circular buffering: on DMA acknowledge For capture channel: when CCx register is read
Retrigger	Yes	Yes			
Count	Yes	Yes			
Capture Overflow Error	Yes				
Debug Fault State	Yes				
Recoverable Faults	Yes				
Non-Recoverable Faults	Yes				
TCCx Event 0 input			Yes <sup>(4)</sup>		
TCCx Event 1 input			Yes <sup>(5)</sup>		

**Notes:**

1. DMA request set on Overflow, Underflow or Re-trigger conditions.
2. Can perform capture or generate recoverable fault on an event input.
3. In Capture or Circular modes.
4. On event input, either action can be executed:
  - re-trigger counter
  - control counter direction
  - stop the counter
  - decrement the counter
  - perform period and pulse width capture
  - generate non-recoverable fault
5. On event input, either action can be executed:
  - re-trigger counter
  - increment or decrement counter depending on direction
  - start the counter
  - increment or decrement counter based on direction
  - increment counter regardless of direction
  - generate non-recoverable fault

#### 49.6.5.1 DMA Operation

The TCC can generate the following DMA requests:



# SAM D5x/E5x Family Data Sheet

## TCC – Timer/Counter for Control Applications

---

<b>Counter overflow (OVF)</b>	<p>If the One-shot Trigger mode in the control A register (CTRLA.DMAOS) is written to '0', the TCC generates a DMA request on each cycle when an update condition (Overflow, Underflow or Re-trigger) is detected.</p> <p>When an update condition (Overflow, Underflow or Re-trigger) is detected while CTRLA.DMAOS=1, the TCC generates a DMA trigger on the cycle following the DMA One-Shot Command written to the Control B register (CTRLBSET.CMD=DMAOS).</p> <p>In both cases, the request is cleared by hardware on DMA acknowledge.</p>
<b>Channel Match (MCx)</b>	<p>A DMA request is set only on a compare match if CTRLA.DMAOS=0. The request is cleared by hardware on DMA acknowledge.</p> <p>When CTRLA.DMAOS=1, the DMA requests are not generated.</p>
<b>Channel Capture (MCx)</b>	<p>For a capture channel, the request is set when valid data is present in the CCx register, and cleared once the CCx register is read.</p> <p>In this operation mode, the CTRLA.DMAOS bit value is ignored.</p>

### DMA Operation with Circular Buffer

When circular buffer operation is enabled, the Buffer registers must be written in a correct order and synchronized to the update times of the timer. The DMA triggers of the TCC provide a way to ensure a safe and correct update of circular buffers.

**Note:** Circular buffer are intended to be used with RAMP2, RAMP2A and DSBOTH operation only.

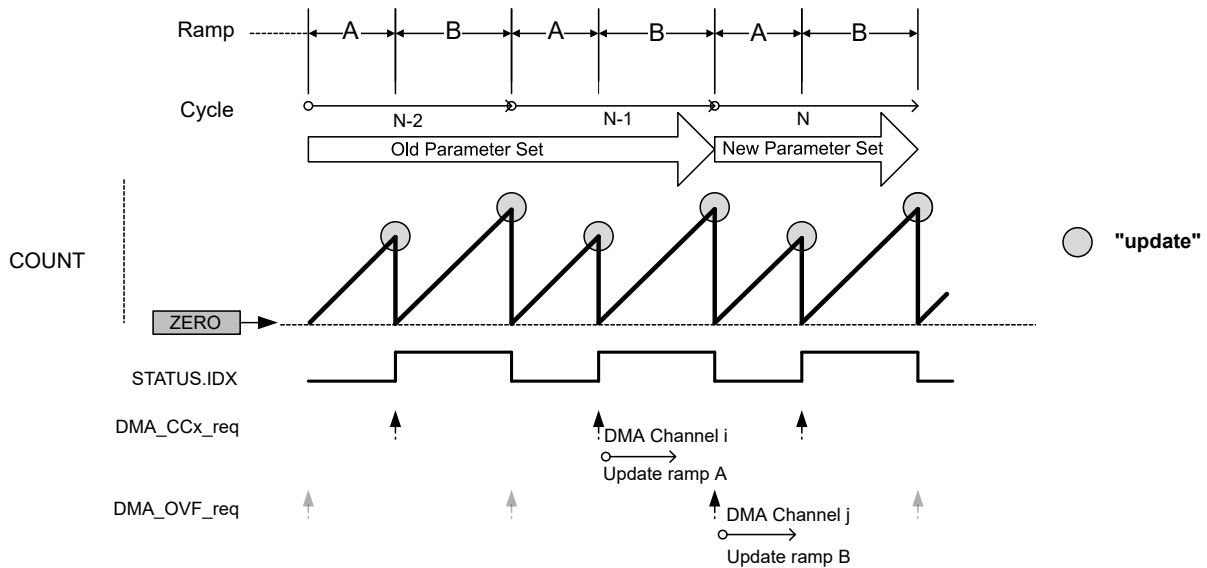
#### *DMA Operation with Circular Buffer in RAMP2 and RAMP2A Mode*

When a CCx channel is selected as a circular buffer, the related DMA request is not set on a compare match detection, but on start of ramp B.

If at least one circular buffer is enabled, the DMA overflow request is conditioned to the start of ramp A with an effective DMA transfer on previous ramp B (DMA acknowledge).

The update of all circular buffer values for ramp A can be done through a DMA channel triggered on a MC trigger. The update of all circular buffer values for ramp B, can be done through a second DMA channel triggered by the overflow DMA request.

**Figure 49-38. DMA Triggers in RAMP and RAMP2 Operation Mode and Circular Buffer Enabled**



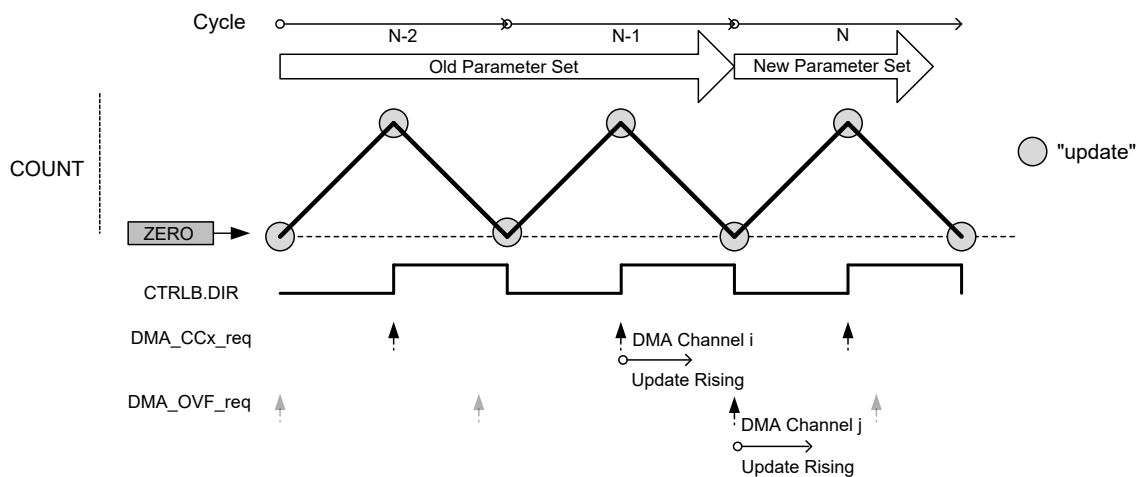
### DMA Operation with Circular Buffer in DSBOTH Mode

When a CC channel is selected as a circular buffer, the related DMA request is not set on a compare match detection, but on start of down-counting phase.

If at least one circular buffer is enabled, the DMA overflow request is conditioned to the start of up-counting phase with an effective DMA transfer on previous down-counting phase (DMA acknowledge).

When up-counting, all circular buffer values can be updated through a DMA channel triggered by MC trigger. When down-counting, all circular buffer values can be updated through a second DMA channel, triggered by the OVF DMA request.

**Figure 49-39. DMA Triggers in DSBOTH Operation Mode and Circular Buffer Enabled**



### 49.6.5.2 Interrupts

The TCC has the following interrupt sources:

- Overflow/Underflow (OVF)
- Retrigger (TRG)

# SAM D5x/E5x Family Data Sheet

## TCC – Timer/Counter for Control Applications

---

- Count (CNT) - refer also to description of [EVCTRL.CNTSEL](#).
- Capture Overflow Error (ERR)
- Non-Recoverable Update Fault (UFS)
- Debug Fault State (DFS)
- Recoverable Faults (FAULTn)
- Non-recoverable Faults (FAULTx)
- Compare Match or Capture Channels (MCx)

These interrupts are asynchronous wake-up sources. See Sleep Mode Entry and Exit Table in PM/Sleep Mode Controller section for details.

Each interrupt source has an Interrupt flag associated with it. The Interrupt flag in the Interrupt Flag Status and Clear (INTFLAG) register is set when the Interrupt condition occurs. Each interrupt can be individually enabled by writing a '1' to the corresponding bit in the Interrupt Enable Set (INTENSET) register, and disabled by writing a '1' to the corresponding bit in the Interrupt Enable Clear (INTENCLR) register. An interrupt request is generated when the Interrupt flag is set and the corresponding interrupt is enabled. The interrupt request remains active until the Interrupt flag is cleared, the interrupt is disabled, or the TCC is reset. See [49.8.12 INTFLAG](#) for details on how to clear Interrupt flags. The TCC has one common interrupt request line for all the interrupt sources. The user must read the INTFLAG register to determine which Interrupt condition is present.

Note: Interrupts must be globally enabled for interrupt requests to be generated. Refer to *Nested Vector Interrupt Controller* for details.

### Related Links

[10.2 Nested Vector Interrupt Controller](#)

#### 49.6.5.3 Events

The TCC can generate the following output events:

- Overflow/Underflow (OVF)
- Trigger (TRG)
- Counter (CNT) For further details, refer to [EVCTRL.CNTSEL](#) description.
- Compare Match or Capture on compare/capture channels: MCx

Writing a '1' ('0') to an Event Output bit in the Event Control Register (EVCTRL.xxEO) enables (disables) the corresponding output event. Refer also to *EVSYS – Event System*.

The TCC can take the following actions on a channel input event (MCx):

- Capture event
- Generate a recoverable or non-recoverable fault

The TCC can take the following actions on counter Event 1 (TCCx EV1):

- Counter re-trigger
- Counter direction control
- Stop the counter
- Decrement the counter on event
- Period and pulse width capture
- Non-recoverable fault

The TCC can take the following actions on counter Event 0 (TCCx EV0):

- Counter re-trigger

# SAM D5x/E5x Family Data Sheet

## TCC – Timer/Counter for Control Applications

---

- Count on event (increment or decrement, depending on counter direction)
- Counter start - start counting on the event rising edge. Further events will not restart the counter; the counter will keep on counting using prescaled GCLK\_TCCx, until it reaches TOP or ZERO, depending on the direction.
- Counter increment on event. This will increment the counter, irrespective of the counter direction.
- Count during active state of an asynchronous event (increment or decrement, depending on counter direction). In this case, the counter will be incremented or decremented on each cycle of the prescaled clock, as long as the event is active.
- Non-recoverable fault

The counter Event Actions are available in the Event Control registers (EVCTRL.EVACT0 and EVCTRL.EVACT1). For further details, refer to [EVCTRL](#).

Writing a '1' ('0') to an Event Input bit in the Event Control register (EVCTRL.MCEIx or EVCTRL.TCEIx) enables (disables) the corresponding action on input event.

**Note:** When several events are connected to the TCC, the enabled action will apply for each of the incoming events. Refer to *EVSYS – Event System* for details on how to configure the event system.

### Related Links

[31. EVSYS – Event System](#)

#### 49.6.6 Sleep Mode Operation

The TCC can be configured to operate in any Sleep mode. To be able to run in standby the RUNSTDBY bit in the Control A register (CTRLA.RUNSTDBY) must be '1'. The MODULE can in any Sleep mode wake-up the device using interrupts or perform actions through the Event System.

#### 49.6.7 Synchronization

Due to asynchronicity between the main clock domain and the peripheral clock domains, some registers need to be synchronized when written or read.

The following bits are synchronized when written:

- Software Reset and Enable bits in Control A register (CTRLA.SWRST and CTRLA.ENABLE)

The following registers are synchronized when written:

- Control B Clear and Control B Set registers (CTRLBCLR and CTRLBSET)
- Status register (STATUS)
- Pattern and Pattern Buffer registers (PATT and PATTBUF)
- Waveform register (WAVE)
- Count Value register (COUNT)
- Period Value and Period Buffer Value registers (PER and PERBUF)
- Compare/Capture Channel x and Channel x Compare/Capture Buffer Value registers (CCx and CCBUFx)

The following registers are synchronized when read:

- Control B Clear and Control B Set registers (CTRLBCLR and CTRLBSET)
- Count Value register (COUNT): synchronization is done on demand through READSYNC command (CTRLBSET.CMD)
- Pattern and Pattern Buffer registers (PATT and PATTBUF)
- Waveform register (WAVE)

# SAM D5x/E5x Family Data Sheet

## TCC – Timer/Counter for Control Applications

---

- Period Value and Period Buffer Value registers (PER and PERBUF)
- Compare/Capture Channel x and Channel x Compare/Capture Buffer Value registers (CCx and CCBUFx)

Required write synchronization is denoted by the "Write-Synchronized" property in the register description.

Required read synchronization is denoted by the "Read-Synchronized" property in the register description.

### Related Links

[13.3 Register Synchronization](#)

# SAM D5x/E5x Family Data Sheet

## TCC – Timer/Counter for Control Applications

### 49.7 Register Summary

Offset	Name	Bit Pos.									
0x00	CTRLA	7:0		RESOLUTION[1:0]					ENABLE	SWRST	
		15:8	MSYNC	ALOCK	PRESCYNC[1:0]		RUNSTDBY	PRESCALER[2:0]			
		23:16	DMAOS								
		31:24			CPTEN5	CPTEN4	CPTEN3	CPTEN2	CPTEN1	CPTEN0	
0x04	CTRLBCLR	7:0	CMD[2:0]			IDXCMD[1:0]		ONESHOT	LUPD	DIR	
0x05	CTRLBSET	7:0	CMD[2:0]			IDXCMD[1:0]		ONESHOT	LUPD	DIR	
0x06 ... 0x07	Reserved										
0x08	SYNCBUSY	7:0	PER	WAVE	PATT	COUNT	STATUS	CTRLB	ENABLE	SWRST	
		15:8			CC5	CC4	CC3	CC2	CC1	CC0	
		23:16									
		31:24									
0x0C	FCTRLA	7:0	RESTART	BLANK[1:0]		QUAL	KEEP		SRC[1:0]		
		15:8	BLANKPRES C	CAPTURE[2:0]			CHSEL[1:0]		HALT[1:0]		
		23:16	BLANKVAL[7:0]								
		31:24	FILTERVAL[3:0]								
0x10	FCTRLBA	7:0	RESTART	BLANK[1:0]		QUAL	KEEP		SRC[1:0]		
		15:8	BLANKPRES C	CAPTURE[2:0]			CHSEL[1:0]		HALT[1:0]		
		23:16	BLANKVAL[7:0]								
		31:24	FILTERVAL[3:0]								
0x14	WEXCTRL	7:0							OTMX[1:0]		
		15:8					DTIEN3	DTIEN2	DTIEN1	DTIEN0	
		23:16	DTLS[7:0]								
		31:24	DTHS[7:0]								
0x18	DRVCTRL	7:0	NRE7	NRE6	NRE5	NRE4	NRE3	NRE2	NRE1	NRE0	
		15:8	NRV7	NRV6	NRV5	NRV4	NRV3	NRV2	NRV1	NRV0	
		23:16	INVEN7	INVEN6	INVEN5	INVEN4	INVEN3	INVEN2	INVEN1	INVEN0	
		31:24	FILTERVAL1[3:0]			FILTERVAL0[3:0]					
0x1C ... 0x1D	Reserved										
0x1E	DBGCTRL	7:0					FDDBD		DBGRUN		
0x1F	Reserved										
0x20	EVCTRL	7:0	CNTSEL[1:0]			EVACT1[2:0]			EVACT0[2:0]		
		15:8	TCEI1	TCEI0	TCINV1	TCINV0		CNTEO	TRGEO	OVFEO	
		23:16					MCEI3	MCEI2	MCEI1	MCEI0	
		31:24					MCEO3	MCEO2	MCEO1	MCEO0	

# SAM D5x/E5x Family Data Sheet

## TCC – Timer/Counter for Control Applications

.....continued											
Offset	Name	Bit Pos.									
0x24	INTENCLR	7:0					ERR	CNT	TRG	OVF	
		15:8	FAULT1	FAULT0	FAULTB	FAULTA	DFS	UFS			
		23:16					MCx3	MCx2	MCx1	MCx0	
		31:24									
0x28	INTENSET	7:0					ERR	CNT	TRG	OVF	
		15:8	FAULT1	FAULT0	FAULTB	FAULTA	DFS	UFS			
		23:16					MC3	MC2	MC1	MC0	
		31:24									
0x2C	INTFLAG	7:0					ERR	CNT	TRG	OVF	
		15:8	FAULT1	FAULT0	FAULTB	FAULTA	DFS	UFS			
		23:16					MC3	MC2	MC1	MC0	
		31:24									
0x30	STATUS	7:0	PERBUFV		PATTBUFV	SLAVE	DFS	UFS	IDX	STOP	
		15:8	FAULT1	FAULT0	FAULTB	FAULTA	FAULT1IN	FAULT0IN	FAULTBIN	FAULTAIN	
		23:16					CCBUFV3	CCBUFV2	CCBUFV1	CCBUFV0	
		31:24					CMP3	CMP2	CMP1	CMP0	
0x34	COUNT	7:0	COUNT[7:0]								
		15:8	COUNT[15:8]								
		23:16	COUNT[23:16]								
		31:24									
0x38	PATT	7:0	PGE[7:0]								
		15:8	PGV[7:0]								
0x3A ... 0x3B	Reserved										
0x3C	WAVE	7:0	CIPEREN		RAMP[1:0]			WAVEGEN[2:0]			
		15:8					CICCEN3	CICCEN2	CICCEN1	CICCEN0	
		23:16			POL5	POL4	POL3	POL2	POL1	POL0	
		31:24					SWAP3	SWAP2	SWAP1	SWAP0	
0x40	PER	7:0	PER[1:0]		DITHER[5:0]						
		15:8	PER[9:2]								
		23:16	PER[17:10]								
		31:24									
0x44	CC0	7:0	CC[1:0]		DITHER[5:0]						
		15:8	CC[9:2]								
		23:16	CC[17:10]								
		31:24									
0x48	CC1	7:0	CC[1:0]		DITHER[5:0]						
		15:8	CC[9:2]								
		23:16	CC[17:10]								
		31:24									
0x4C	CC2	7:0	CC[1:0]		DITHER[5:0]						
		15:8	CC[9:2]								
		23:16	CC[17:10]								
		31:24									

# SAM D5x/E5x Family Data Sheet

## TCC – Timer/Counter for Control Applications

.....continued				
Offset	Name	Bit Pos.		
0x50	CC3	7:0	CC[1:0]	DITHER[5:0]
		15:8		CC[9:2]
		23:16		CC[17:10]
		31:24		
0x54	CC4	7:0	CC[1:0]	DITHER[5:0]
		15:8		CC[9:2]
		23:16		CC[17:10]
		31:24		
0x58	CC5	7:0	CC[1:0]	DITHER[5:0]
		15:8		CC[9:2]
		23:16		CC[17:10]
		31:24		
0x5C ... 0x63	Reserved			
0x64	PATTBUF	7:0		PGEB0[7:0]
		15:8		PGVB0[7:0]
0x66 ... 0x6B	Reserved			
0x6C	PERBUF	7:0	PERBUF[1:0]	DITHERBUF[5:0]
		15:8		PERBUF[9:2]
		23:16		PERBUF[17:10]
		31:24		
0x70	CCBUF0	7:0	CCBUF[1:0]	DITHERBUF[5:0]
		15:8		CCBUF[9:2]
		23:16		CCBUF[17:10]
		31:24		
0x74	CCBUF1	7:0	CCBUF[1:0]	DITHERBUF[5:0]
		15:8		CCBUF[9:2]
		23:16		CCBUF[17:10]
		31:24		
0x78	CCBUF2	7:0	CCBUF[1:0]	DITHERBUF[5:0]
		15:8		CCBUF[9:2]
		23:16		CCBUF[17:10]
		31:24		
0x7C	CCBUF3	7:0	CCBUF[1:0]	DITHERBUF[5:0]
		15:8		CCBUF[9:2]
		23:16		CCBUF[17:10]
		31:24		
0x80	CCBUF4	7:0	CCBUF[1:0]	DITHERBUF[5:0]
		15:8		CCBUF[9:2]
		23:16		CCBUF[17:10]
		31:24		



# SAM D5x/E5x Family Data Sheet

## TCC – Timer/Counter for Control Applications

.....continued

Offset	Name	Bit Pos.							
0x84	CCBUF5	7:0	CCBUF[1:0]	DITHERBUF[5:0]					
		15:8	CCBUF[9:2]						
		23:16	CCBUF[17:10]						
		31:24							

### 49.8 Register Description

Registers can be 8, 16, or 32 bits wide. Atomic 8-, 16-, and 32-bit accesses are supported. In addition, the 8-bit quarters and 16-bit halves of a 32-bit register, and the 8-bit halves of a 16-bit register can be accessed directly.

Some registers require synchronization when read and/or written. Synchronization is denoted by the "Read-Synchronized" and/or "Write-Synchronized" property in each individual register description.

Optional write protection by the Peripheral Access Controller (PAC) is denoted by the "PAC Write Protection" property in each individual register description.

Some registers are enable-protected, meaning they can only be written when the module is disabled. Enable protection is denoted by the "Enable-Protected" property in each individual register description.

# SAM D5x/E5x Family Data Sheet

## TCC – Timer/Counter for Control Applications

### 49.8.1 Control A

**Name:** CTRLA  
**Offset:** 0x00  
**Reset:** 0x00000000  
**Property:** PAC Write-Protection, Enable-Protected, Write-Synchronized (ENABLE, SWRST)

	Bit	31	30	29	28	27	26	25	24
				CPTEN5	CPTEN4	CPTEN3	CPTEN2	CPTEN1	CPTEN0
Access				R/W	R/W	R/W	R/W	R/W	R/W
Reset				0	0	0	0	0	0
	Bit	23	22	21	20	19	18	17	16
		DMAOS							
Access		R/W							
Reset		0							
	Bit	15	14	13	12	11	10	9	8
		MSYNC	ALOCK	PRESCYNC[1:0]		RUNSTDBY	PRESCALER[2:0]		
Access		R/W	R/W	R/W	R/W	R/W	R/W	R/W	R/W
Reset		0	0	0	0	0	0	0	0
	Bit	7	6	5	4	3	2	1	0
			RESOLUTION[1:0]					ENABLE	SWRST
Access			R/W	R/W				R/W	R/W
Reset			0	0				0	0

**Bits 24, 25, 26, 27, 28, 29 – CPTEN** Capture Channel x Enable

These bits are used to select the capture or compare operation on channel x. Writing a '1' to CPTENx enables capture on channel x. Writing a '0' to CPTENx disables capture on channel x.

**Bit 23 – DMAOS** DMA One-Shot Trigger Mode

This bit enables the DMA One-shot Trigger Mode. Writing a '1' to this bit will generate a DMA trigger on TCC cycle following a TCC\_CTRLBSET\_CMD\_DMAOS command. Writing a '0' to this bit will generate DMA triggers on each TCC cycle. This bit is not synchronized.

**Bit 15 – MSYNC** Master Synchronization (only for TCC slave instance)

This bit must be set if the TCC counting operation must be synchronized on its Master TCC. This bit is not synchronized.

Value	Description
0	The TCC controls its own counter.
1	The counter is controlled by its Master TCC.

**Bit 14 – ALOCK** Auto Lock

This bit is not synchronized.

# SAM D5x/E5x Family Data Sheet

## TCC – Timer/Counter for Control Applications

Value	Description
0	The Lock Update bit in the Control B register (CTRLB.LUPD) is not affected by overflow/underflow, and re-trigger events
1	CTRLB.LUPD is set to '1' on each overflow/underflow or re-trigger event.

### Bits 13:12 – PRESCYNC[1:0] Prescaler and Counter Synchronization

These bits select if on re-trigger event, the Counter is cleared or reloaded on either the next GCLK\_TCCx clock, or on the next prescaled GCLK\_TCCx clock. It is also possible to reset the prescaler on re-trigger event.

These bits are not synchronized.

Value	Name	Description	
		Counter Reloaded	Prescaler
0x0	GCLK	Reload or reset Counter on next GCLK	-
0x1	PRESC	Reload or reset Counter on next prescaler clock	-
0x2	RESYNC	Reload or reset Counter on next GCLK	Reset prescaler counter
0x3	Reserved		

### Bit 11 – RUNSTDBY Run in Standby

This bit is used to keep the TCC running in Standby mode.

This bit is not synchronized.

Value	Description
0	The TCC is halted in standby.
1	The TCC continues to run in standby.

### Bits 10:8 – PRESCALER[2:0] Prescaler

These bits select the Counter prescaler factor.

These bits are not synchronized.

Value	Name	Description
0x0	DIV1	Prescaler: GCLK_TCC
0x1	DIV2	Prescaler: GCLK_TCC/2
0x2	DIV4	Prescaler: GCLK_TCC/4
0x3	DIV8	Prescaler: GCLK_TCC/8
0x4	DIV16	Prescaler: GCLK_TCC/16
0x5	DIV64	Prescaler: GCLK_TCC/64
0x6	DIV256	Prescaler: GCLK_TCC/256
0x7	DIV1024	Prescaler: GCLK_TCC/1024

### Bits 6:5 – RESOLUTION[1:0] Dithering Resolution

These bits increase the TCC resolution by enabling the dithering options.

These bits are not synchronized.

# SAM D5x/E5x Family Data Sheet

## TCC – Timer/Counter for Control Applications

**Table 49-7. Dithering**

Value	Name	Description
0x0	NONE	The dithering is disabled.
0x1	DITH4	Dithering is done every 16 PWM frames. PER[3:0] and CCx[3:0] contain dithering pattern selection.
0x2	DITH5	Dithering is done every 32 PWM frames. PER[4:0] and CCx[4:0] contain dithering pattern selection.
0x3	DITH6	Dithering is done every 64 PWM frames. PER[5:0] and CCx[5:0] contain dithering pattern selection.

**Bit 1 – ENABLE** Enable

Due to synchronization there is delay from writing CTRLA.ENABLE until the peripheral is enabled/disabled. The value written to CTRLA.ENABLE will read back immediately and the ENABLE bit in the SYNCBUSY register (SYNCBUSY.ENABLE) will be set. SYNCBUSY.ENABLE will be cleared when the operation is complete.

Value	Description
0	The peripheral is disabled.
1	The peripheral is enabled.

**Bit 0 – SWRST** Software Reset

Writing a '0' to this bit has no effect.

Writing a '1' to this bit resets all registers in the TCC (except DBGCTRL) to their initial state, and the TCC will be disabled.

Writing a '1' to CTRLA.SWRST will always take precedence; all other writes in the same write-operation will be discarded.

Due to synchronization there is a delay from writing CTRLA.SWRST until the reset is complete. CTRLA.SWRST and SYNCBUSY.SWRST will both be cleared when the reset is complete.

Value	Description
0	There is no Reset operation ongoing.
1	The Reset operation is ongoing.

# SAM D5x/E5x Family Data Sheet

## TCC – Timer/Counter for Control Applications

### 49.8.2 Control B Clear

**Name:** CTRLBCLR  
**Offset:** 0x04  
**Reset:** 0x00  
**Property:** PAC Write-Protection, Write-Synchronized, Read-Synchronized

This register allows the user to change this register without doing a read-modify-write operation. Changes in this register will also be reflected in the Control B Set (CTRLBSET) register.

Bit	7	6	5	4	3	2	1	0
	CMD[2:0]			IDXCMD[1:0]		ONESHOT	LUPD	DIR
Access	R/W	R/W	R/W	R/W	R/W	R/W	R/W	R/W
Reset	0	0	0	0	0	0	0	0

#### Bits 7:5 – CMD[2:0] TCC Command

These bits can be used for software control of re-triggering and stop commands of the TCC. When a command has been executed, the CMD bit field will read back zero. The commands are executed on the next prescaled GCLK\_TCC clock cycle.

Writing zero to this bit group has no effect.

Writing a '1' to any of these bits will clear the pending command.

Value	Name	Description
0x0	NONE	No action
0x1	RETRIGGER	Clear start, restart or retrigger
0x2	STOP	Force stop
0x3	UPDATE	Force update of double buffered registers
0x4	READSYNC	Force COUNT read synchronization
0x5	DMAOS	One-shot DMA trigger

#### Bits 4:3 – IDXCMD[1:0] Ramp Index Command

These bits can be used to force cycle A and cycle B changes in RAMP2 and RAMP2A operation. On timer/counter update condition, the command is executed, the IDX flag in STATUS register is updated and the IDXCMD command is cleared.

Writing zero to these bits has no effect.

Writing a '1' to any of these bits will clear the pending command.

Value	Name	Description
0x0	DISABLE	DISABLE Command disabled: IDX toggles between cycles A and B
0x1	SET	Set IDX: cycle B will be forced in the next cycle
0x2	CLEAR	Clear IDX: cycle A will be forced in next cycle
0x3	HOLD	Hold IDX: the next cycle will be the same as the current cycle.

#### Bit 2 – ONESHOT One-Shot

This bit controls one-shot operation of the TCC. When one-shot operation is enabled, the TCC will stop counting on the next overflow/underflow condition or on a stop command.

Writing a '0' to this bit has no effect

Writing a '1' to this bit will disable the one-shot operation.

Value	Description
0	The TCC will update the counter value on overflow/underflow condition and continue operation.

# SAM D5x/E5x Family Data Sheet

## TCC – Timer/Counter for Control Applications

Value	Description
1	The TCC will stop counting on the next underflow/overflow condition.

### Bit 1 – LUPD Lock Update

This bit controls the update operation of the TCC buffered registers.

When CTRLB.LUPD is cleared, the hardware UPDATE registers with value from their buffered registers is enabled.

This bit has no effect when input capture operation is enabled.

Writing a '0' to this bit has no effect.

Writing a '1' to this bit will enable the registers updates on hardware UPDATE condition.

Value	Description
0	The CCBx, PERB, PGVB, PGOB, and SWAPBx buffer registers values <i>are</i> copied into the corresponding CCx, PER, PGV, PGO and SWAPx registers on hardware update condition.
1	The CCBx, PERB, PGVB, PGOB, and SWAPBx buffer registers values are <i>not</i> copied into the corresponding CCx, PER, PGV, PGO and SWAPx registers on hardware update condition.

### Bit 0 – DIR Counter Direction

This bit is used to change the direction of the counter.

Writing a '0' to this bit has no effect

Writing a '1' to this bit will clear the bit and make the counter count up.

Value	Description
0	The timer/counter is counting up (incrementing).
1	The timer/counter is counting down (decrementing).

# SAM D5x/E5x Family Data Sheet

## TCC – Timer/Counter for Control Applications

### 49.8.3 Control B Set

**Name:** CTRLBSET  
**Offset:** 0x05  
**Reset:** 0x00  
**Property:** PAC Write-Protection, Write-Synchronized, Read-Synchronized

This register allows the user to change this register without doing a read-modify-write operation. Changes in this register will also be reflected in the Control B Set (CTRLBCLR) register.

Bit	7	6	5	4	3	2	1	0
	CMD[2:0]			IDXCMD[1:0]		ONESHOT	LUPD	DIR
Access	R/W	R/W	R/W	R/W	R/W	R/W	R/W	R/W
Reset	0	0	0	0	0	0	0	0

#### Bits 7:5 – CMD[2:0] TCC Command

These bits can be used for software control of re-triggering and stop commands of the TCC. When a command has been executed, the CMD bit field will be read back as zero. The commands are executed on the next prescaled GCLK\_TCC clock cycle.

Writing zero to this bit group has no effect

Writing a valid value to this bit group will set the associated command.

Value	Name	Description
0x0	NONE	No action
0x1	RETRIGGER	Force start, restart or retrigger
0x2	STOP	Force stop
0x3	UPDATE	Force update of double buffered registers
0x4	READSYNC	Force a read synchronization of COUNT
0x5	DMAOS	One-shot DMA trigger

#### Bits 4:3 – IDXCMD[1:0] Ramp Index Command

These bits can be used to force cycle A and cycle B changes in RAMP2 and RAMP2A operation. On timer/counter update condition, the command is executed, the IDX flag in STATUS register is updated and the IDXCMD command is cleared.

Writing a zero to these bits has no effect.

Writing a valid value to these bits will set a command.

Value	Name	Description
0x0	DISABLE	Command disabled: IDX toggles between cycles A and B
0x1	SET	Set IDX: cycle B will be forced in the next cycle
0x2	CLEAR	Clear IDX: cycle A will be forced in next cycle
0x3	HOLD	Hold IDX: the next cycle will be the same as the current cycle.

#### Bit 2 – ONESHOT One-Shot

This bit controls one-shot operation of the TCC. When in one-shot operation, the TCC will stop counting on the next overflow/underflow condition or a stop command.

Writing a '0' to this bit has no effect.

Writing a '1' to this bit will enable the one-shot operation.

Value	Description
0	The TCC will count continuously.
1	The TCC will stop counting on the next underflow/overflow condition.

# SAM D5x/E5x Family Data Sheet

## TCC – Timer/Counter for Control Applications

### Bit 1 – LUPD Lock Update

This bit controls the update operation of the TCC buffered registers.

When CTRLB.LUPD is set, the hardware UPDATE registers with value from their buffered registers is disabled. Disabling the update ensures that all buffer registers are valid before an hardware update is performed. After all the buffer registers are loaded correctly, the buffered registers can be unlocked.

This bit has no effect when input capture operation is enabled.

Writing a '0' to this bit has no effect.

Writing a '1' to this bit will disable the registers updates on hardware UPDATE condition.

Value	Description
0	The CCBx, PERB, PGVB, PGOB, and SWAPBx buffer registers values <i>are</i> copied into the corresponding CCx, PER, PGV, PGO and SWAPx registers on hardware update condition.
1	The CCBx, PERB, PGVB, PGOB, and SWAPBx buffer registers values are <i>not</i> copied into CCx, PER, PGV, PGO and SWAPx registers on hardware update condition.

### Bit 0 – DIR Counter Direction

This bit is used to change the direction of the counter.

Writing a '0' to this bit has no effect

Writing a '1' to this bit will clear the bit and make the counter count up.

Value	Description
0	The timer/counter is counting up (incrementing).
1	The timer/counter is counting down (decrementing).



# SAM D5x/E5x Family Data Sheet

## TCC – Timer/Counter for Control Applications

### 49.8.4 Synchronization Busy

**Name:** SYNCBUSY  
**Offset:** 0x08  
**Reset:** 0x00000000  
**Property:** -

Bit	31	30	29	28	27	26	25	24
Access								
Reset								
Bit	23	22	21	20	19	18	17	16
Access								
Reset								
Bit	15	14	13	12	11	10	9	8
			CC5	CC4	CC3	CC2	CC1	CC0
Access			R	R	R	R	R	R
Reset			0	0	0	0	0	0
Bit	7	6	5	4	3	2	1	0
	PER	WAVE	PATT	COUNT	STATUS	CTRLB	ENABLE	SWRST
Access	R	R	R	R	R	R	R	R
Reset	0	0	0	0	0	0	0	0

**Bits 8, 9, 10, 11, 12, 13 – CC** Compare/Capture Channel x Synchronization Busy

This bit is cleared when the synchronization of Compare/Capture Channel x register between the clock domains is complete.

This bit is set when the synchronization of Compare/Capture Channel x register between clock domains is started.

CCx bit is available only for existing Compare/Capture Channels. For details on CC channels number, refer to each TCC feature list.

This bit is set when the synchronization of CCx register between clock domains is started.

**Bit 7 – PER** PER Synchronization Busy

This bit is cleared when the synchronization of PER register between the clock domains is complete.

This bit is set when the synchronization of PER register between clock domains is started.

**Bit 6 – WAVE** WAVE Synchronization Busy

This bit is cleared when the synchronization of WAVE register between the clock domains is complete.

This bit is set when the synchronization of WAVE register between clock domains is started.

**Bit 5 – PATT** PATT Synchronization Busy

This bit is cleared when the synchronization of PATTERN register between the clock domains is complete.

This bit is set when the synchronization of PATTERN register between clock domains is started.

# SAM D5x/E5x Family Data Sheet

## TCC – Timer/Counter for Control Applications

---

---

### **Bit 4 – COUNT** COUNT Synchronization Busy

This bit is cleared when the synchronization of COUNT register between the clock domains is complete.  
This bit is set when the synchronization of COUNT register between clock domains is started.

### **Bit 3 – STATUS** STATUS Synchronization Busy

This bit is cleared when the synchronization of STATUS register between the clock domains is complete.  
This bit is set when the synchronization of STATUS register between clock domains is started.

### **Bit 2 – CTRLB** CTRLB Synchronization Busy

This bit is cleared when the synchronization of CTRLB register between the clock domains is complete.  
This bit is set when the synchronization of CTRLB register between clock domains is started.

### **Bit 1 – ENABLE** ENABLE Synchronization Busy

This bit is cleared when the synchronization of ENABLE bit between the clock domains is complete.  
This bit is set when the synchronization of ENABLE bit between clock domains is started.

### **Bit 0 – SWRST** SWRST Synchronization Busy

This bit is cleared when the synchronization of SWRST bit between the clock domains is complete.  
This bit is set when the synchronization of SWRST bit between clock domains is started.

# SAM D5x/E5x Family Data Sheet

## TCC – Timer/Counter for Control Applications

### 49.8.5 Fault Control A and B

**Name:** FCTRLA, FCTRLB  
**Offset:** 0x0C + n\*0x04 [n=0..1]  
**Reset:** 0x00000000  
**Property:** PAC Write-Protection, Enable-Protected

Bit	31	30	29	28	27	26	25	24
	FILTERVAL[3:0]							
Access					R/W	R/W	R/W	R/W
Reset					0	0	0	0
Bit	23	22	21	20	19	18	17	16
	BLANKVAL[7:0]							
Access	R/W	R/W	R/W	R/W	R/W	R/W	R/W	R/W
Reset	0	0	0	0	0	0	0	0
Bit	15	14	13	12	11	10	9	8
	BLANKPRESC	CAPTURE[2:0]			CHSEL[1:0]		HALT[1:0]	
Access	R/W	R/W	R/W	R/W	R/W	R/W	R/W	R/W
Reset	0	0	0	0	0	0	0	0
Bit	7	6	5	4	3	2	1	0
	RESTART	BLANK[1:0]		QUAL	KEEP		SRC[1:0]	
Access	R/W	R/W	R/W	R/W	R/W		R/W	R/W
Reset	0	0	0	0	0		0	0

**Bits 27:24 – FILTERVAL[3:0]** Recoverable Fault n Filter Value

These bits define the filter value applied on MCE<sub>x</sub> (x=0,1) event input line. The value must be set to zero when MCE<sub>x</sub> event is used as synchronous event.

**Bits 23:16 – BLANKVAL[7:0]** Recoverable Fault n Blanking Value

These bits determine the duration of the blanking of the fault input source. Activation and edge selection of the blank filtering are done by the BLANK bits (FCTRL<sub>n</sub>.BLANK). When enabled, the fault input source is internally disabled for BLANKVAL\* prescaled GCLK\_TCC periods after the detection of the waveform edge.

**Bit 15 – BLANKPRESC** Recoverable Fault n Blanking Value Prescaler

This bit enables a factor 64 prescaler factor on used as base frequency of the BLANKVAL value.

Value	Description
0	Blank time is BLANKVAL* prescaled GCLK_TCC.
1	Blank time is BLANKVAL* 64 * prescaled GCLK_TCC.

**Bits 14:12 – CAPTURE[2:0]** Recoverable Fault n Capture Action

These bits select the capture and Fault n interrupt/event conditions.

# SAM D5x/E5x Family Data Sheet

## TCC – Timer/Counter for Control Applications

**Table 49-8. Fault n Capture Action**

Value	Name	Description
0x0	DISABLE	Capture on valid recoverable Fault n is disabled
0x1	CAPT	On rising edge of a valid recoverable Fault n, capture counter value on channel selected by CHSEL[1:0]. INTFLAG.FAULTn flag rises on each new captured value.
0x2	CAPTMIN	On rising edge of a valid recoverable Fault n, capture counter value on channel selected by CHSEL[1:0], if COUNT value is lower than the last stored capture value (CC). INTFLAG.FAULTn flag rises on each local minimum detection.
0x3	CAPTMAX	On rising edge of a valid recoverable Fault n, capture counter value on channel selected by CHSEL[1:0], if COUNT value is higher than the last stored capture value (CC). INTFLAG.FAULTn flag rises on each local maximum detection.
0x4	LOCMIN	On rising edge of a valid recoverable Fault n, capture counter value on channel selected by CHSEL[1:0]. INTFLAG.FAULTn flag rises on each local minimum value detection.
0x5	LOCMAX	On rising edge of a valid recoverable Fault n, capture counter value on channel selected by CHSEL[1:0]. INTFLAG.FAULTn flag rises on each local maximum detection.
0x6	DERIV0	On rising edge of a valid recoverable Fault n, capture counter value on channel selected by CHSEL[1:0]. INTFLAG.FAULTn flag rises on each local maximum or minimum detection.
0x7	CAPTMARK	Capture with ramp index as MSB value.

**Bits 11:10 – CHSEL[1:0]** Recoverable Fault n Capture Channel

These bits select the channel for capture operation triggered by recoverable Fault n.

Value	Name	Description
0x0	CC0	Capture value stored into CC0
0x1	CC1	Capture value stored into CC1
0x2	CC2	Capture value stored into CC2
0x3	CC3	Capture value stored into CC3

**Bits 9:8 – HALT[1:0]** Recoverable Fault n Halt Operation

These bits select the halt action for recoverable Fault n.

Value	Name	Description
0x0	DISABLE	Halt action disabled
0x1	HW	Hardware halt action
0x2	SW	Software halt action
0x3	NR	Non-recoverable fault

**Bit 7 – RESTART** Recoverable Fault n Restart

Setting this bit enables restart action for Fault n.

Value	Description
0	Fault n restart action is disabled.
1	Fault n restart action is enabled.

# SAM D5x/E5x Family Data Sheet

## TCC – Timer/Counter for Control Applications

### Bits 6:5 – BLANK[1:0] Recoverable Fault n Blanking Operation

These bits, select the blanking start point for recoverable Fault n.

Value	Name	Description
0x0	START	Blanking applied from start of the Ramp period
0x1	RISE	Blanking applied from rising edge of the waveform output
0x2	FALL	Blanking applied from falling edge of the waveform output
0x3	BOTH	Blanking applied from each toggle of the waveform output

### Bit 4 – QUAL Recoverable Fault n Qualification

Setting this bit enables the recoverable Fault n input qualification.

Value	Description
0	The recoverable Fault n input is not disabled on CMPx value condition.
1	The recoverable Fault n input is disabled when output signal is at inactive level (CMPx == 0).

### Bit 3 – KEEP Recoverable Fault n Keep

Setting this bit enables the Fault n keep action.

Value	Description
0	The Fault n state is released as soon as the recoverable Fault n is released.
1	The Fault n state is released at the end of TCC cycle.

### Bits 1:0 – SRC[1:0] Recoverable Fault n Source

These bits select the TCC event input for recoverable Fault n.

Event system channel connected to MCEx event input, must be configured to route the event asynchronously, when used as a recoverable Fault n input.

Value	Name	Description
0x0	DISABLE	Fault input disabled
0x1	ENABLE	MCEx (x=0,1) event input
0x2	INVERT	Inverted MCEx (x=0,1) event input
0x3	ALTFAULT	Alternate fault (A or B) state at the end of the previous period.

# SAM D5x/E5x Family Data Sheet

## TCC – Timer/Counter for Control Applications

### 49.8.6 Waveform Extension Control

**Name:** WEXCTRL  
**Offset:** 0x14  
**Reset:** 0x00000000  
**Property:** PAC Write-Protection, Enable-Protected

Bit	31	30	29	28	27	26	25	24
	DTHS[7:0]							
Access	R/W	R/W	R/W	R/W	R/W	R/W	R/W	R/W
Reset	0	0	0	0	0	0	0	0
Bit	23	22	21	20	19	18	17	16
	DTLS[7:0]							
Access	R/W	R/W	R/W	R/W	R/W	R/W	R/W	R/W
Reset	0	0	0	0	0	0	0	0
Bit	15	14	13	12	11	10	9	8
					DTIEN3	DTIEN2	DTIEN1	DTIEN0
Access					R/W	R/W	R/W	R/W
Reset					0	0	0	0
Bit	7	6	5	4	3	2	1	0
							OTMX[1:0]	
Access							R/W	R/W
Reset							0	0

**Bits 31:24 – DTHS[7:0]** Dead-Time High Side Outputs Value  
 This register holds the number of GCLK\_TCC clock cycles for the dead-time high side.

**Bits 23:16 – DTLS[7:0]** Dead-time Low Side Outputs Value  
 This register holds the number of GCLK\_TCC clock cycles for the dead-time low side.

**Bits 8, 9, 10, 11 – DTIEN** Dead-time Insertion Generator x Enable  
 Setting any of these bits enables the dead-time insertion generator for the corresponding output matrix. This will override the output matrix [x] and [x+WO\_NUM/2], with the low side and high side waveform respectively.

Value	Description
0	No dead-time insertion override.
1	Dead time insertion override on signal outputs[x] and [x+WO_NUM/2], from matrix outputs[x] signal.

**Bits 1:0 – OTMX[1:0]** Output Matrix  
 These bits define the matrix routing of the TCC waveform generation outputs to the port pins, according to [49.6.3.8 Waveform Extension](#).

# SAM D5x/E5x Family Data Sheet

## TCC – Timer/Counter for Control Applications

### 49.8.7 Driver Control

**Name:** DRVCTRL  
**Offset:** 0x18  
**Reset:** 0x00000000  
**Property:** PAC Write-Protection, Enable-Protected

	Bit	31	30	29	28	27	26	25	24
		FILTERVAL1[3:0]				FILTERVAL0[3:0]			
Access		R/W	R/W	R/W	R/W	R/W	R/W	R/W	R/W
Reset		0	0	0	0	0	0	0	0
	Bit	23	22	21	20	19	18	17	16
		INVEN7	INVEN6	INVEN5	INVEN4	INVEN3	INVEN2	INVEN1	INVEN0
Access		R/W	R/W	R/W	R/W	R/W	R/W	R/W	R/W
Reset		0	0	0	0	0	0	0	0
	Bit	15	14	13	12	11	10	9	8
		NRV7	NRV6	NRV5	NRV4	NRV3	NRV2	NRV1	NRV0
Access		R/W	R/W	R/W	R/W	R/W	R/W	R/W	R/W
Reset		0	0	0	0	0	0	0	0
	Bit	7	6	5	4	3	2	1	0
		NRE7	NRE6	NRE5	NRE4	NRE3	NRE2	NRE1	NRE0
Access		R/W	R/W	R/W	R/W	R/W	R/W	R/W	R/W
Reset		0	0	0	0	0	0	0	0

**Bits 31:28 – FILTERVAL1[3:0]** Non-Recoverable Fault Input 1 Filter Value

These bits define the filter value applied on TCE1 event input line. When the TCE1 event input line is configured as a synchronous event, this value must be 0x0.

**Bits 27:24 – FILTERVAL0[3:0]** Non-Recoverable Fault Input 0 Filter Value

These bits define the filter value applied on TCE0 event input line. When the TCE0 event input line is configured as a synchronous event, this value must be 0x0.

**Bits 16, 17, 18, 19, 20, 21, 22, 23 – INVEN** Waveform Output x Inversion

These bits are used to select inversion on the output of channel x.

Writing a '1' to INVENx inverts output from WO[x].

Writing a '0' to INVENx disables inversion of output from WO[x].

**Bits 8, 9, 10, 11, 12, 13, 14, 15 – NRV** NRVx Non-Recoverable State x Output Value

These bits define the value of the enabled override outputs, under non-recoverable fault condition.

**Bits 0, 1, 2, 3, 4, 5, 6, 7 – NRE** Non-Recoverable State x Output Enable

These bits enable the override of individual outputs by NRVx value, under non-recoverable fault condition.

Value	Description
0	Non-recoverable fault tri-state the output.
1	Non-recoverable faults set the output to NRVx level.

# SAM D5x/E5x Family Data Sheet

## TCC – Timer/Counter for Control Applications

### 49.8.8 Debug control

**Name:** DBGCTRL  
**Offset:** 0x1E  
**Reset:** 0x00  
**Property:** PAC Write-Protection

	7	6	5	4	3	2	1	0
						FDDBD		
Access						R/W	R/W	
Reset						0	0	

#### Bit 2 – FDDBD Fault Detection on Debug Break Detection

This bit is not affected by software Reset and should not be changed by software while the TCC is enabled.

By default this bit is zero, and the on-chip debug (OCD) fault protection is disabled. When this bit is written to '1', OCD break request from the OCD system will trigger non-recoverable fault. When this bit is set, OCD fault protection is enabled and OCD break request from the OCD system will trigger a non-recoverable fault.

Value	Description
0	No faults are generated when TCC is halted in Debug mode.
1	A non recoverable fault is generated and FAULTD flag is set when TCC is halted in Debug mode.

#### Bit 0 – DBGRUN Debug Running State

This bit is not affected by software Reset and should not be changed by software while the TCC is enabled.

Value	Description
0	The TCC is halted when the device is halted in Debug mode.
1	The TCC continues normal operation when the device is halted in Debug mode.



# SAM D5x/E5x Family Data Sheet

## TCC – Timer/Counter for Control Applications

### 49.8.9 Event Control

**Name:** EVCTRL  
**Offset:** 0x20  
**Reset:** 0x00000000  
**Property:** PAC Write-Protection, Enable-Protected

	31	30	29	28	27	26	25	24	
					MCEO3	MCEO2	MCEO1	MCEO0	
Access					R/W	R/W	R/W	R/W	
Reset					0	0	0	0	
	23	22	21	20	19	18	17	16	
					MCEI3	MCEI2	MCEI1	MCEI0	
Access					R/W	R/W	R/W	R/W	
Reset					0	0	0	0	
	15	14	13	12	11	10	9	8	
	TCEI1	TCEI0	TCINV1	TCINV0			CNTEO	TRGEO	OVFEO
Access	R/W	R/W	R/W	R/W			R/W	R/W	R/W
Reset	0	0	0	0			0	0	0
	7	6	5	4	3	2	1	0	
	CNTSEL[1:0]		EVACT1[2:0]			EVACT0[2:0]			
Access	R/W	R/W	R/W	R/W	R/W	R/W	R/W	R/W	
Reset	0	0	0	0	0	0	0	0	

#### Bits 24, 25, 26, 27 – MCEO Match or Capture Channel x Event Output Enable

These bits control if the match/capture event on channel x is enabled and will be generated for every match or capture.

Value	Description
0	Match/capture x event is disabled and will not be generated.
1	Match/capture x event is enabled and will be generated for every compare/capture on channel x.

#### Bits 16, 17, 18, 19 – MCEI Match or Capture Channel x Event Input Enable

These bits indicate if the match/capture x incoming event is enabled. These bits are used to enable match or capture input events to the CCx channel of TCC.

Value	Description
0	Incoming events are disabled.
1	Incoming events are enabled.

#### Bits 14, 15 – TCEI Timer/Counter Event Input x Enable

This bit is used to enable input event x to the TCC.

Value	Description
0	Incoming event x is disabled.
1	Incoming event x is enabled.

# SAM D5x/E5x Family Data Sheet

## TCC – Timer/Counter for Control Applications

### Bits 12, 13 – TCINV Timer/Counter Event x Invert Enable

This bit inverts the event x input.

Value	Description
0	Input event source x is not inverted.
1	Input event source x is inverted.

### Bit 10 – CNTEO Timer/Counter Event Output Enable

This bit is used to enable the counter cycle event. When enabled, an event will be generated on begin or end of counter cycle depending of CNTSEL[1:0] settings.

Value	Description
0	Counter cycle output event is disabled and will not be generated.
1	Counter cycle output event is enabled and will be generated depend of CNTSEL[1:0] value.

### Bit 9 – TRGEO Retrigger Event Output Enable

This bit is used to enable the counter retrigger event. When enabled, an event will be generated when the counter retriggers operation.

Value	Description
0	Counter retrigger event is disabled and will not be generated.
1	Counter retrigger event is enabled and will be generated for every counter retrigger.

### Bit 8 – OVFE0 Overflow/Underflow Event Output Enable

This bit is used to enable the overflow/underflow event. When enabled an event will be generated when the counter reaches the TOP or the ZERO value.

Value	Description
0	Overflow/underflow counter event is disabled and will not be generated.
1	Overflow/underflow counter event is enabled and will be generated for every counter overflow/underflow.

### Bits 7:6 – CNTSEL[1:0] Timer/Counter Interrupt and Event Output Selection

These bits define on which part of the counter cycle the counter event output is generated.

Value	Name	Description
0x0	BEGIN	An interrupt/event is generated at begin of each counter cycle
0x1	END	An interrupt/event is generated at end of each counter cycle
0x2	BETWEEN	An interrupt/event is generated between each counter cycle.
0x3	BOUNDARY	An interrupt/event is generated at begin of first counter cycle, and end of last counter cycle.

### Bits 5:3 – EVACT1[2:0] Timer/Counter Event Input 1 Action

These bits define the action the TCC will perform on TCE1 event input.

Value	Name	Description
0x0	OFF	Event action disabled.
0x1	RETRIGGER	Start, restart or re-trigger TC on event
0x2	DIR (asynch)	Direction control
0x3	STOP	Stop TC on event
0x4	DEC	Decrement TC on event
0x5	PPW	Period captured into CC0 Pulse Width on CC1
0x6	PWP	Period captured into CC1 Pulse Width on CC0
0x7	FAULT	Non-recoverable Fault

# SAM D5x/E5x Family Data Sheet

## TCC – Timer/Counter for Control Applications

### Bits 2:0 – EVACT0[2:0] Timer/Counter Event Input 0 Action

These bits define the action the TCC will perform on TCE0 event input 0.

Value	Name	Description
0x0	OFF	Event action disabled.
0x1	RETRIGGER	Start, restart or re-trigger TC on event
0x2	COUNTEV	Count on event.
0x3	START	Start TC on event
0x4	INC	Increment TC on EVENT
0x5	COUNT (async)	Count on active state of asynchronous event
0x6	STAMP	Capture overflow times (Max value)
0x7	FAULT	Non-recoverable Fault

# SAM D5x/E5x Family Data Sheet

## TCC – Timer/Counter for Control Applications

### 49.8.10 Interrupt Enable Clear

**Name:** INTENCLR  
**Offset:** 0x24  
**Reset:** 0x00000000  
**Property:** PAC Write-Protection

This register allows the user to enable an interrupt without doing a read-modify-write operation. Changes in this register will also be reflected in the Interrupt Enable Set (INTENSET) register.

Bit	31	30	29	28	27	26	25	24
Access								
Reset								
Bit	23	22	21	20	19	18	17	16
					MCx3	MCx2	MCx1	MCx0
Access					R/W	R/W	R/W	R/W
Reset					0	0	0	0
Bit	15	14	13	12	11	10	9	8
	FAULT1	FAULT0	FAULTB	FAULTA	DFS	UFS		
Access	R/W	R/W	R/W	R/W	R/W	R/W		
Reset	0	0	0	0	0	0		
Bit	7	6	5	4	3	2	1	0
					ERR	CNT	TRG	OVF
Access					R/W	R/W	R/W	R/W
Reset					0	0	0	0

#### Bits 16, 17, 18, 19 – MCx Match or Capture Channel x Interrupt Enable

Writing a '0' to this bit has no effect.

Writing a '1' to this bit will clear the corresponding Match or Capture Channel x Interrupt Disable/Enable bit, which disables the Match or Capture Channel x interrupt.

Value	Description
0	The Match or Capture Channel x interrupt is disabled.
1	The Match or Capture Channel x interrupt is enabled.

#### Bit 15 – FAULT1 Non-Recoverable Fault x Interrupt Enable

Writing a '0' to this bit has no effect.

Writing a '1' to this bit will clear the Non-Recoverable Fault x Interrupt Disable/Enable bit, which disables the Non-Recoverable Fault x interrupt.

Value	Description
0	The Non-Recoverable Fault x interrupt is disabled.
1	The Non-Recoverable Fault x interrupt is enabled.

#### Bit 14 – FAULT0 Non-Recoverable Fault x Interrupt Enable

Writing a '0' to this bit has no effect.

Writing a '1' to this bit will clear the Non-Recoverable Fault x Interrupt Disable/Enable bit, which disables the Non-Recoverable Fault x interrupt.

# SAM D5x/E5x Family Data Sheet

## TCC – Timer/Counter for Control Applications

Value	Description
0	The Non-Recoverable Fault x interrupt is disabled.
1	The Non-Recoverable Fault x interrupt is enabled.

### Bit 13 – FAULTB Recoverable Fault B Interrupt Enable

Writing a '0' to this bit has no effect.

Writing a '1' to this bit will clear the Recoverable Fault B Interrupt Disable/Enable bit, which disables the Recoverable Fault B interrupt.

Value	Description
0	The Recoverable Fault B interrupt is disabled.
1	The Recoverable Fault B interrupt is enabled.

### Bit 12 – FAULTA Recoverable Fault A Interrupt Enable

Writing a '0' to this bit has no effect.

Writing a '1' to this bit will clear the Recoverable Fault A Interrupt Disable/Enable bit, which disables the Recoverable Fault A interrupt.

Value	Description
0	The Recoverable Fault A interrupt is disabled.
1	The Recoverable Fault A interrupt is enabled.

### Bit 11 – DFS Non-Recoverable Debug Fault Interrupt Enable

Writing a '0' to this bit has no effect.

Writing a '1' to this bit will clear the Debug Fault State Interrupt Disable/Enable bit, which disables the Debug Fault State interrupt.

Value	Description
0	The Debug Fault State interrupt is disabled.
1	The Debug Fault State interrupt is enabled.

### Bit 10 – UFS Non-Recoverable Update Fault Interrupt Enable

Writing a zero to this bit has no effect.

Writing a one to this bit will clear the Non-Recoverable Update Fault Interrupt Disable/Enable bit, which disables the Non-Recoverable Update Fault interrupt.

**Note:** This bit is only available on variant L devices. Refer to the *Configuration Summary* for more information.

Value	Description
0	The Non-Recoverable Update Fault interrupt is disabled.
1	The Non-Recoverable Update Fault interrupt is enabled.

### Bit 3 – ERR Error Interrupt Enable

Writing a '0' to this bit has no effect.

Writing a '1' to this bit will clear the Error Interrupt Disable/Enable bit, which disables the Compare interrupt.

Value	Description
0	The Error interrupt is disabled.
1	The Error interrupt is enabled.

### Bit 2 – CNT Counter Interrupt Enable

Writing a '0' to this bit has no effect.

# SAM D5x/E5x Family Data Sheet

## TCC – Timer/Counter for Control Applications

Writing a '1' to this bit will clear the Counter Interrupt Disable/Enable bit, which disables the Counter interrupt.

Value	Description
0	The Counter interrupt is disabled.
1	The Counter interrupt is enabled.

### Bit 1 – TRG Retrigger Interrupt Enable

Writing a '0' to this bit has no effect.

Writing a '1' to this bit will clear the Retrigger Interrupt Disable/Enable bit, which disables the Retrigger interrupt.

Value	Description
0	The Retrigger interrupt is disabled.
1	The Retrigger interrupt is enabled.

### Bit 0 – OVF Overflow Interrupt Enable

Writing a '0' to this bit has no effect.

Writing a '1' to this bit will clear the Overflow Interrupt Disable/Enable bit, which disables the Overflow interrupt request.

Value	Description
0	The Overflow interrupt is disabled.
1	The Overflow interrupt is enabled.

# SAM D5x/E5x Family Data Sheet

## TCC – Timer/Counter for Control Applications

### 49.8.11 Interrupt Enable Set

**Name:** INTENSET  
**Offset:** 0x28  
**Reset:** 0x00000000  
**Property:** PAC Write-Protection

This register allows the user to enable an interrupt without doing a read-modify-write operation. Changes in this register will also be reflected in the Interrupt Enable Clear (INTENCLR) register.

Bit	31	30	29	28	27	26	25	24
Access								
Reset								
Bit	23	22	21	20	19	18	17	16
					MC3	MC2	MC1	MC0
Access					R/W	R/W	R/W	R/W
Reset					0	0	0	0
Bit	15	14	13	12	11	10	9	8
	FAULT1	FAULT0	FAULTB	FAULTA	DFS	UFS		
Access	R/W	R/W	R/W	R/W	R/W	R/W		
Reset	0	0	0	0	0	0		
Bit	7	6	5	4	3	2	1	0
					ERR	CNT	TRG	OVF
Access					R/W	R/W	R/W	R/W
Reset					0	0	0	0

#### Bits 16, 17, 18, 19 – MC Match or Capture Channel x Interrupt Enable

Writing a '0' to this bit has no effect.

Writing a '1' to this bit will set the corresponding Match or Capture Channel x Interrupt Disable/Enable bit, which enables the Match or Capture Channel x interrupt.

Value	Description
0	The Match or Capture Channel x interrupt is disabled.
1	The Match or Capture Channel x interrupt is enabled.

#### Bit 15 – FAULT1 Non-Recoverable Fault x Interrupt Enable

Writing a '0' to this bit has no effect.

Writing a '1' to this bit will set the Non-Recoverable Fault x Interrupt Disable/Enable bit, which enables the Non-Recoverable Fault x interrupt.

Value	Description
0	The Non-Recoverable Fault x interrupt is disabled.
1	The Non-Recoverable Fault x interrupt is enabled.

#### Bit 14 – FAULT0 Non-Recoverable Fault x Interrupt Enable

Writing a '0' to this bit has no effect.

Writing a '1' to this bit will clear the Non-Recoverable Fault x Interrupt Disable/Enable bit, which disables the Non-Recoverable Fault x interrupt.

# SAM D5x/E5x Family Data Sheet

## TCC – Timer/Counter for Control Applications

Value	Description
0	The Non-Recoverable Fault x interrupt is disabled.
1	The Non-Recoverable Fault x interrupt is enabled.

### Bit 13 – FAULTB Recoverable Fault B Interrupt Enable

Writing a '0' to this bit has no effect.

Writing a '1' to this bit will set the Recoverable Fault B Interrupt Disable/Enable bit, which enables the Recoverable Fault B interrupt.

Value	Description
0	The Recoverable Fault B interrupt is disabled.
1	The Recoverable Fault B interrupt is enabled.

### Bit 12 – FAULTA Recoverable Fault A Interrupt Enable

Writing a '0' to this bit has no effect.

Writing a '1' to this bit will set the Recoverable Fault A Interrupt Disable/Enable bit, which enables the Recoverable Fault A interrupt.

Value	Description
0	The Recoverable Fault A interrupt is disabled.
1	The Recoverable Fault A interrupt is enabled.

### Bit 11 – DFS Non-Recoverable Debug Fault Interrupt Enable

Writing a '0' to this bit has no effect.

Writing a '1' to this bit will set the Debug Fault State Interrupt Disable/Enable bit, which enables the Debug Fault State interrupt.

Value	Description
0	The Debug Fault State interrupt is disabled.
1	The Debug Fault State interrupt is enabled.

### Bit 10 – UFS Non-Recoverable Update Fault Interrupt Enable

Writing a zero to this bit has no effect.

Writing a one to this bit will set the Non-Recoverable Update Fault Interrupt Disable/Enable bit, which enables the Non-Recoverable Update Fault interrupt.

**Note:** This bit is only available on variant L devices. Refer to the *Configuration Summary* for more information.

Value	Description
0	The Non-Recoverable Update Fault interrupt is disabled.
1	The Non-Recoverable Update Fault interrupt is enabled.

### Bit 3 – ERR Error Interrupt Enable

Writing a '0' to this bit has no effect.

Writing a '1' to this bit will set the Error Interrupt Disable/Enable bit, which enables the Compare interrupt.

Value	Description
0	The Error interrupt is disabled.
1	The Error interrupt is enabled.

### Bit 2 – CNT Counter Interrupt Enable

Writing a '0' to this bit has no effect.

Writing a '1' to this bit will set the Retrigger Interrupt Disable/Enable bit, which enables the Counter interrupt.



# SAM D5x/E5x Family Data Sheet

## TCC – Timer/Counter for Control Applications

Value	Description
0	The Counter interrupt is disabled.
1	The Counter interrupt is enabled.

### Bit 1 – TRG Retrigger Interrupt Enable

Writing a '0' to this bit has no effect.

Writing a '1' to this bit will set the Retrigger Interrupt Disable/Enable bit, which enables the Retrigger interrupt.

Value	Description
0	The Retrigger interrupt is disabled.
1	The Retrigger interrupt is enabled.

### Bit 0 – OVF Overflow Interrupt Enable

Writing a '0' to this bit has no effect.

Writing a '1' to this bit will set the Overflow Interrupt Disable/Enable bit, which enables the Overflow interrupt request.

Value	Description
0	The Overflow interrupt is disabled.
1	The Overflow interrupt is enabled.

# SAM D5x/E5x Family Data Sheet

## TCC – Timer/Counter for Control Applications

### 49.8.12 Interrupt Flag Status and Clear

**Name:** INTFLAG  
**Offset:** 0x2C  
**Reset:** 0x00000000  
**Property:** -

	Bit	31	30	29	28	27	26	25	24
Access									
Reset									
	Bit	23	22	21	20	19	18	17	16
						MC3	MC2	MC1	MC0
Access						R/W	R/W	R/W	R/W
Reset						0	0	0	0
	Bit	15	14	13	12	11	10	9	8
		FAULT1	FAULT0	FAULTB	FAULTA	DFS	UFS		
Access		R/W	R/W	R/W	R/W	R/W	R/W		
Reset		0	0	0	0	0	0		
	Bit	7	6	5	4	3	2	1	0
						ERR	CNT	TRG	OVF
Access						R/W	R/W	R/W	R/W
Reset						0	0	0	0

**Bits 16, 17, 18, 19 – MC Match or Capture Channel x Interrupt Flag**

This flag is set on the next CLK\_TCC\_COUNT cycle after a match with the compare condition or once CCx register contain a valid capture value.

Writing a '0' to one of these bits has no effect.

Writing a '1' to one of these bits will clear the corresponding Match or Capture Channel x interrupt flag  
 In Capture operation, this flag is automatically cleared when CCx register is read.

**Bit 15 – FAULT1 Non-Recoverable Fault x Interrupt Flag**

This flag is set on the next CLK\_TCC\_COUNT cycle after a Non-Recoverable Fault x occurs.

Writing a '0' to this bit has no effect.

Writing a '1' to this bit clears the Non-Recoverable Fault x interrupt flag.

**Bit 14 – FAULT0 Non-Recoverable Fault x Interrupt Enable**

Writing a '0' to this bit has no effect.

Writing a '1' to this bit will clear the Non-Recoverable Fault x Interrupt Disable/Enable bit, which disables the Non-Recoverable Fault x interrupt.

Value	Description
0	The Non-Recoverable Fault x interrupt is disabled.
1	The Non-Recoverable Fault x interrupt is enabled.

**Bit 13 – FAULTB Recoverable Fault B Interrupt Flag**

This flag is set on the next CLK\_TCC\_COUNT cycle after a Recoverable Fault B occurs.

# SAM D5x/E5x Family Data Sheet

## TCC – Timer/Counter for Control Applications

---

Writing a '0' to this bit has no effect.

Writing a '1' to this bit clears the Recoverable Fault B interrupt flag.

### **Bit 12 – FAULTA** Recoverable Fault A Interrupt Flag

This flag is set on the next CLK\_TCC\_COUNT cycle after a Recoverable Fault B occurs.

Writing a '0' to this bit has no effect.

Writing a '1' to this bit clears the Recoverable Fault B interrupt flag.

### **Bit 11 – DFS** Non-Recoverable Debug Fault State Interrupt Flag

This flag is set on the next CLK\_TCC\_COUNT cycle after an Debug Fault State occurs.

Writing a '0' to this bit has no effect.

Writing a '1' to this bit clears the Debug Fault State interrupt flag.

### **Bit 10 – UFS** Non-Recoverable Update Fault

This flag is set when the RAMP index changes and the Lock Update bit is set (CTRLBSET.LUPD).

Writing a zero to this bit has no effect.

Writing a one to this bit clears the Non-Recoverable Update Fault interrupt flag.

**Note:** This bit is only available on variant L devices. Refer to the *Configuration Summary* for more information.

### **Bit 3 – ERR** Error Interrupt Flag

This flag is set if a new capture occurs on a channel when the corresponding Match or Capture Channel x interrupt flag is one. In which case there is nowhere to store the new capture.

Writing a '0' to this bit has no effect.

Writing a '1' to this bit clears the error interrupt flag.

### **Bit 2 – CNT** Counter Interrupt Flag

This flag is set on the next CLK\_TCC\_COUNT cycle after a counter event occurs.

Writing a '0' to this bit has no effect.

Writing a '1' to this bit clears the CNT interrupt flag.

### **Bit 1 – TRG** Retrigger Interrupt Flag

This flag is set on the next CLK\_TCC\_COUNT cycle after a counter retrigger occurs.

Writing a '0' to this bit has no effect.

Writing a '1' to this bit clears the re-trigger interrupt flag.

### **Bit 0 – OVF** Overflow Interrupt Flag

This flag is set on the next CLK\_TCC\_COUNT cycle after an overflow condition occurs.

Writing a '0' to this bit has no effect.

Writing a '1' to this bit clears the Overflow interrupt flag.

# SAM D5x/E5x Family Data Sheet

## TCC – Timer/Counter for Control Applications

### 49.8.13 Status

**Name:** STATUS  
**Offset:** 0x30  
**Reset:** 0x00000001  
**Property:** -

	Bit	31	30	29	28	27	26	25	24
						CMP3	CMP2	CMP1	CMP0
Access						R/W	R/W	R/W	R/W
Reset						0	0	0	0
	Bit	23	22	21	20	19	18	17	16
						CCBUFV3	CCBUFV2	CCBUFV1	CCBUFV0
Access						R/W	R/W	R/W	R/W
Reset						0	0	0	0
	Bit	15	14	13	12	11	10	9	8
		FAULT1	FAULT0	FAULTB	FAULTA	FAULT1IN	FAULT0IN	FAULTBIN	FAULTAIN
Access		R/W	R/W	R/W	R/W	R	R	R	R
Reset		0	0	0	0	0	0	0	0
	Bit	7	6	5	4	3	2	1	0
		PERBUFV		PATTBUFV	SLAVE	DFS	UFS	IDX	STOP
Access		R/W		R/W	R	R/W	R/W	R	R
Reset		0		0	0	0	0	0	1

#### Bits 24, 25, 26, 27 – CMP Channel x Compare Value

This bit reflects the channel x output compare value.

Value	Description
0	Channel compare output value is 0.
1	Channel compare output value is 1.

#### Bits 16, 17, 18, 19 – CCBUFV Channel x Compare or Capture Buffer Valid

For a compare channel, this bit is set when a new value is written to the corresponding CCBUFx register. The bit is cleared either by writing a '1' to the corresponding location when CTRLB.LUPD is set, or automatically on an UPDATE condition.

For a capture channel, the bit is set when a valid capture value is stored in the CCBUFx register. The bit is automatically cleared when the CCx register is read.

#### Bits 14, 15 – FAULT Non-recoverable Fault x State

This bit is set by hardware as soon as non-recoverable Fault x condition occurs.

This bit is cleared by writing a one to this bit and when the corresponding FAULTxIN status bit is low.

Once this bit is clear, the timer/counter will restart from the last COUNT value. To restart the timer/counter from BOTTOM, the timer/counter restart command must be executed before clearing the corresponding STATEx bit. For further details on timer/counter commands, refer to available commands description ([49.8.3 CTRLBSET.CMD](#)).

# SAM D5x/E5x Family Data Sheet

## TCC – Timer/Counter for Control Applications

---

### **Bit 13 – FAULTB** Recoverable Fault B State

This bit is set by hardware as soon as recoverable Fault B condition occurs.

This bit can be clear by hardware when Fault B action is resumed, or by writing a '1' to this bit when the corresponding FAULTBIN bit is low. If software halt command is enabled (FAULTB.HALT=SW), clearing this bit will release the timer/counter.

### **Bit 12 – FAULTA** Recoverable Fault A State

This bit is set by hardware as soon as recoverable Fault A condition occurs.

This bit can be clear by hardware when Fault A action is resumed, or by writing a '1' to this bit when the corresponding FAULTAIN bit is low. If software halt command is enabled (FAULTA.HALT=SW), clearing this bit will release the timer/counter.

### **Bit 11 – FAULT1IN** Non-Recoverable Fault 1 Input

This bit is set while an active Non-Recoverable Fault 1 input is present.

### **Bit 10 – FAULT0IN** Non-Recoverable Fault 0 Input

This bit is set while an active Non-Recoverable Fault 0 input is present.

### **Bit 9 – FAULTBIN** Recoverable Fault B Input

This bit is set while an active Recoverable Fault B input is present.

### **Bit 8 – FAULTAIN** Recoverable Fault A Input

This bit is set while an active Recoverable Fault A input is present.

### **Bit 7 – PERBUFV** Period Buffer Valid

This bit is set when a new value is written to the PERBUF register. This bit is automatically cleared by hardware on UPDATE condition when CTRLB.LUPD is set, or by writing a '1' to this bit.

### **Bit 5 – PATTBUFV** Pattern Generator Value Buffer Valid

This bit is set when a new value is written to the PATTBUF register. This bit is automatically cleared by hardware on UPDATE condition when CTRLB.LUPD is set, or by writing a '1' to this bit.

### **Bit 4 – SLAVE** Slave

This bit is set when TCC is set in Slave mode. This bit follows the CTRLA.MSYNC bit state.

### **Bit 3 – DFS** Debug Fault State

This bit is set by hardware in Debug mode when DDBGCTRL.FDDBD bit is set. The bit is cleared by writing a '1' to this bit and when the TCC is not in Debug mode.

When the bit is set, the counter is halted and the Waveforms state depend on DRVCTRL.NRE and DRVCTRL.NRV registers.

### **Bit 2 – UFS** Non-recoverable Update Fault State

This bit is set by hardware when the RAMP index changes and the Lock Update bit is set (CTRLBSET.LUPD). The bit is cleared by writing a one to this bit.

When the bit is set, the waveforms state depend on DRVCTRL.NRE and DRVCTRL.NRV registers.

### **Bit 1 – IDX** Ramp Index

In RAMP2 and RAMP2A operation, the bit is cleared during the cycle A and set during the cycle B. In RAMP1 operation, the bit always reads zero. For details on ramp operations, refer to [49.6.3.4 Ramp Operations](#).

# SAM D5x/E5x Family Data Sheet

## TCC – Timer/Counter for Control Applications

---

---

### Bit 0 – STOP Stop

This bit is set when the TCC is disabled either on a STOP command or on an UPDATE condition when One-Shot operation mode is enabled (CTRLBSET.ONESHOT=1).

This bit is clear on the next incoming counter increment or decrement.

Value	Description
0	Counter is running.
1	Counter is stopped.

# SAM D5x/E5x Family Data Sheet

## TCC – Timer/Counter for Control Applications

### 49.8.14 Counter Value

**Name:** COUNT  
**Offset:** 0x34  
**Reset:** 0x00000000  
**Property:** PAC Write-Protection, Write-Synchronized, Read-Synchronized

**Note:** Prior to any read access, this register must be synchronized by user by writing the according TCC Command value to the Control B Set register (CTRLBSET.CMD=READSYNC).

Bit	31	30	29	28	27	26	25	24
Access								
Reset								
Bit	23	22	21	20	19	18	17	16
	COUNT[23:16]							
Access	R/W	R/W	R/W	R/W	R/W	R/W	R/W	R/W
Reset	0	0	0	0	0	0	0	0
Bit	15	14	13	12	11	10	9	8
	COUNT[15:8]							
Access	R/W	R/W	R/W	R/W	R/W	R/W	R/W	R/W
Reset	0	0	0	0	0	0	0	0
Bit	7	6	5	4	3	2	1	0
	COUNT[7:0]							
Access	R/W	R/W	R/W	R/W	R/W	R/W	R/W	R/W
Reset	0	0	0	0	0	0	0	0

**Bits 23:0 – COUNT[23:0]** Counter Value

These bits hold the value of the Counter register.

**Note:** When the TCC is configured as 16-bit timer/counter, the excess bits are read zero.

**Note:** This bit field occupies the MSB of the register, [23:m]. m is dependent on the Resolution bit in the Control A register (CTRLA.RESOLUTION):

CTRLA.RESOLUTION	Bits [23:m]
0x0 - NONE	23:0 (depicted)
0x1 - DITH4	23:4
0x2 - DITH5	23:5
0x3 - DITH6	23:6

# SAM D5x/E5x Family Data Sheet

## TCC – Timer/Counter for Control Applications

### 49.8.15 Pattern

**Name:** PATT  
**Offset:** 0x38  
**Reset:** 0x0000  
**Property:** Write-Synchronized

	Bit	15	14	13	12	11	10	9	8
		PGV[7:0]							
Access		R/W	R/W	R/W	R/W	R/W	R/W	R/W	R/W
Reset		0	0	0	0	0	0	0	0
	Bit	7	6	5	4	3	2	1	0
		PGE[7:0]							
Access		R/W	R/W	R/W	R/W	R/W	R/W	R/W	R/W
Reset		0	0	0	0	0	0	0	0

**Bits 15:8 – PGV[7:0]** Pattern Generation Output Value

This register holds the values of pattern for each waveform output.

**Bits 7:0 – PGE[7:0]** Pattern Generation Output Enable

This register holds the enable status of pattern generation for each waveform output. A bit written to '1' will override the corresponding SWAP output with the corresponding PGVn value.



# SAM D5x/E5x Family Data Sheet

## TCC – Timer/Counter for Control Applications

### 49.8.16 Waveform

**Name:** WAVE  
**Offset:** 0x3C  
**Reset:** 0x00000000  
**Property:** Write-Synchronized

	Bit	31	30	29	28	27	26	25	24
						SWAP3	SWAP2	SWAP1	SWAP0
Access						R/W	R/W	R/W	R/W
Reset						0	0	0	0
	Bit	23	22	21	20	19	18	17	16
				POL5	POL4	POL3	POL2	POL1	POL0
Access				R/W	R/W	R/W	R/W	R/W	R/W
Reset				0	0	0	0	0	0
	Bit	15	14	13	12	11	10	9	8
						CICCEN3	CICCEN2	CICCEN1	CICCEN0
Access						R/W	R/W	R/W	R/W
Reset						0	0	0	0
	Bit	7	6	5	4	3	2	1	0
		CIPEREN		RAMP[1:0]			WAVEGEN[2:0]		
Access		R/W		R/W	R/W		R/W	R/W	R/W
Reset		0		0	0		0	0	0

**Bits 24, 25, 26, 27 – SWAP** Swap DTI Output Pair x  
 Setting these bits enables output swap of DTI outputs [x] and [x+WO\_NUM/2]. Note the DTIxEN settings will not affect the swap operation.

**Bits 16, 17, 18, 19, 20, 21 – POL** Channel Polarity x  
 Setting these bits enables the output polarity in single-slope and dual-slope PWM operations.

Value	Name	Description
0	(single-slope PWM waveform generation)	Compare output is initialized to ~DIR and set to DIR when TCC counter matches CCx value
1	(single-slope PWM waveform generation)	Compare output is initialized to DIR and set to ~DIR when TCC counter matches CCx value.
0	(dual-slope PWM waveform generation)	Compare output is set to ~DIR when TCC counter matches CCx value
1	(dual-slope PWM waveform generation)	Compare output is set to DIR when TCC counter matches CCx value.

**Bits 8, 9, 10, 11 – CICCEN** Circular CC Enable x  
 Setting this bits enables the compare circular buffer option on the first four Compare/Capture channels. When the bit is set, CCx register value is copied-back into the CCx register on UPDATE condition.

# SAM D5x/E5x Family Data Sheet

## TCC – Timer/Counter for Control Applications

### Bit 7 – CIPEREN Circular Period Enable

Setting this bits enable the period circular buffer option. When the bit is set, the PER register value is copied-back into the PERB register on UPDATE condition.

### Bits 5:4 – RAMP[1:0] Ramp Operation

These bits select Ramp operation (RAMP). These bits are not synchronized.

Value	Name	Description
0x0	RAMP1	RAMP1 operation
0x1	RAMP2A	Alternative RAMP2 operation
0x2	RAMP2	RAMP2 operation
0x3	RAMP2C	Critical RAMP2 operation
0x4	-	Reserved

### Bits 2:0 – WAVEGEN[2:0] Waveform Generation Operation

These bits select the waveform generation operation. The settings impact the top value and control if frequency or PWM waveform generation should be used. These bits are not synchronized.

Value	Name	Description						
		Operation	Top	Update	Waveform Output On Match	Waveform Output On Update	OVFIF/Event Up Down	
0x0	NFRQ	Normal Frequency	PER	TOP/Zero	Toggle	Stable	TOP	Zero
0x1	MFRQ	Match Frequency	CC0	TOP/Zero	Toggle	Stable	TOP	Zero
0x2	NPWM	Normal PWM	PER	TOP/Zero	Set	Clear	TOP	Zero
0x3	Reserved	-	-	-	-	-	-	-
0x4	DSCRITICAL	Dual-slope PWM	PER	Zero	~DIR	Stable	-	Zero
0x5	DSBOTTOM	Dual-slope PWM	PER	Zero	~DIR	Stable	-	Zero
0x6	DSBOTH	Dual-slope PWM	PER	TOP & Zero	~DIR	Stable	TOP	Zero
0x7	DSTOP	Dual-slope PWM	PER	Zero	~DIR	Stable	TOP	-

# SAM D5x/E5x Family Data Sheet

## TCC – Timer/Counter for Control Applications

### 49.8.17 Period Value

**Name:** PER  
**Offset:** 0x40  
**Reset:** 0xFFFFFFFF  
**Property:** Write-Synchronized

Bit	31	30	29	28	27	26	25	24
Access								
Reset								
Bit	23	22	21	20	19	18	17	16
	PER[17:10]							
Access	R/W	R/W	R/W	R/W	R/W	R/W	R/W	R/W
Reset	1	1	1	1	1	1	1	1
Bit	15	14	13	12	11	10	9	8
	PER[9:2]							
Access	R/W	R/W	R/W	R/W	R/W	R/W	R/W	R/W
Reset	1	1	1	1	1	1	1	1
Bit	7	6	5	4	3	2	1	0
	PER[1:0]		DITHER[5:0]					
Access	R/W	R/W	R/W	R/W	R/W	R/W	R/W	R/W
Reset	1	1	1	1	1	1	1	1

#### Bits 23:6 – PER[17:0] Period Value

These bits hold the value of the Period Buffer register.

**Note:** When the TCC is configured as 16-bit timer/counter, the excess bits are read zero.

**Note:** This bit field occupies the MSB of the register, [23:m]. m is dependent on the Resolution bit in the Control A register (CTRLA.RESOLUTION):

CTRLA.RESOLUTION	Bits [23:m]
0x0 - NONE	23:0
0x1 - DITH4	23:4
0x2 - DITH5	23:5
0x3 - DITH6	23:6 (depicted)

#### Bits 5:0 – DITHER[5:0] Dithering Cycle Number

These bits hold the number of extra cycles that are added on the PWM pulse period every 64 PWM frames.

# SAM D5x/E5x Family Data Sheet

## TCC – Timer/Counter for Control Applications

**Note:** This bit field consists of the n LSB of the register. n is dependent on the value of the Resolution bits in the Control A register (CTRLA.RESOLUTION):

CTRLA.RESOLUTION	Bits [n:0]
0x0 - NONE	-
0x1 - DITH4	3:0
0x2 - DITH5	4:0
0x3 - DITH6	5:0 (depicted)

# SAM D5x/E5x Family Data Sheet

## TCC – Timer/Counter for Control Applications

### 49.8.18 Compare/Capture Channel x

**Name:** CC  
**Offset:** 0x44 + n\*0x04 [n=0..5]  
**Reset:** 0x00000000  
**Property:** Write-Synchronized, Read-Synchronized

The CCx register represents the 16-, 24- bit value, CCx. The register has two functions, depending of the mode of operation.

For capture operation, this register represents the second buffer level and access point for the CPU and DMA.

For compare operation, this register is continuously compared to the counter value. Normally, the output from the comparator is then used for generating waveforms.

CCx register is updated with the buffer value from their corresponding CCBUFx register when an UPDATE condition occurs.

In addition, in match frequency operation, the CC0 register controls the counter period.

Bit	31	30	29	28	27	26	25	24
Access								
Reset								
Bit	23	22	21	20	19	18	17	16
Access	CC[17:10]							
Reset	0							
Bit	15	14	13	12	11	10	9	8
Access	CC[9:2]							
Reset	0							
Bit	7	6	5	4	3	2	1	0
Access	CC[1:0]		DITHER[5:0]					
Reset	0		0					

**Bits 23:6 – CC[17:0]** Channel x Compare/Capture Value

These bits hold the value of the Channel x compare/capture register.

# SAM D5x/E5x Family Data Sheet

## TCC – Timer/Counter for Control Applications

**Note:**

1. When the TCC is configured as a 16-bit timer/counter, the excess bits are read as zero.
2. This bit field occupies the MSB of the register, [23:m]. m is dependent on the Resolution bit in the Control A register (CTRLA.RESOLUTION):

CTRLA.RESOLUTION	Bits [23:m]
0x0 - NONE	23:0
0x1 - DITH4	23:4
0x2 - DITH5	23:5
0x3 - DITH6	23:6 (depicted)

**Bits 5:0 – DITHER[5:0]** Dithering Cycle Number

These bits hold the number of extra cycles that are added on the PWM pulse width every 64 PWM frames.

**Note:** This bit field consists of the n LSB of the register. n is dependent on the value of the Resolution bits in the Control A register (CTRLA.RESOLUTION):

CTRLA.RESOLUTION	Bits [n:0]
0x0 - NONE	-
0x1 - DITH4	3:0
0x2 - DITH5	4:0
0x3 - DITH6	5:0 (depicted)

# SAM D5x/E5x Family Data Sheet

## TCC – Timer/Counter for Control Applications

### 49.8.19 Pattern Buffer

**Name:** PATTBUF  
**Offset:** 0x64  
**Reset:** 0x0000  
**Property:** Write-Synchronized, Read-Synchronized

	Bit	15	14	13	12	11	10	9	8
	PGVB0[7:0]								
Access	R/W	R/W	R/W	R/W	R/W	R/W	R/W	R/W	R/W
Reset	0	0	0	0	0	0	0	0	0
	Bit	7	6	5	4	3	2	1	0
	PGE0[7:0]								
Access	R/W	R/W	R/W	R/W	R/W	R/W	R/W	R/W	R/W
Reset	0	0	0	0	0	0	0	0	0

**Bits 8:15, 16:23, 24:31, 32:39, 40:47, 48:55, 56:63, 64:71 – PGVB** Pattern Generation Output Value Buffer

This register is the buffer for the PGV register. If double buffering is used, valid content in this register is copied to the PGV register on an UPDATE condition.

**Bits 0:7, 8:15, 16:23, 24:31, 32:39, 40:47, 48:55, 56:63 – PGE0** Pattern Generation Output Enable Buffer

This register is the buffer of the PGE register. If double buffering is used, valid content in this register is copied into the PGE register at an UPDATE condition.

# SAM D5x/E5x Family Data Sheet

## TCC – Timer/Counter for Control Applications

### 49.8.20 Period Buffer Value

**Name:** PERBUF  
**Offset:** 0x6C  
**Reset:** 0xFFFFFFFF  
**Property:** Write-Synchronized, Read-Synchronized

Bit	31	30	29	28	27	26	25	24
Access								
Reset								
Bit	23	22	21	20	19	18	17	16
	PERBUF[17:10]							
Access	R/W	R/W	R/W	R/W	R/W	R/W	R/W	R/W
Reset	1	1	1	1	1	1	1	1
Bit	15	14	13	12	11	10	9	8
	PERBUF[9:2]							
Access	R/W	R/W	R/W	R/W	R/W	R/W	R/W	R/W
Reset	1	1	1	1	1	1	1	1
Bit	7	6	5	4	3	2	1	0
	PERBUF[1:0]		DITHERBUF[5:0]					
Access	R/W	R/W	R/W	R/W	R/W	R/W	R/W	R/W
Reset	1	1	1	1	1	1	1	1

#### Bits 23:6 – PERBUF[17:0] Period Buffer Value

These bits hold the value of the Period Buffer register. The value is copied to PER register on UPDATE condition.

**Note:** When the TCC is configured as 16-bit timer/counter, the excess bits are read zero.

**Note:** This bit field occupies the MSB of the register, [23:m]. m is dependent on the Resolution bit in the Control A register (CTRLA.RESOLUTION):

CTRLA.RESOLUTION	Bits [23:m]
0x0 - NONE	23:0
0x1 - DITH4	23:4
0x2 - DITH5	23:5
0x3 - DITH6	23:6 (depicted)

#### Bits 5:0 – DITHERBUF[5:0] Dithering Buffer Cycle Number

These bits represent the PER.DITHER bits buffer. When the double buffering is enabled, the value of this bit field is copied to the PER.DITHER bits on an UPDATE condition.



# SAM D5x/E5x Family Data Sheet

## TCC – Timer/Counter for Control Applications

**Note:** This bit field consists of the n LSB of the register. n is dependent on the value of the Resolution bits in the Control A register (CTRLA.RESOLUTION):

CTRLA.RESOLUTION	Bits [n:0]
0x0 - NONE	-
0x1 - DITH4	3:0
0x2 - DITH5	4:0
0x3 - DITH6	5:0 (depicted)

# SAM D5x/E5x Family Data Sheet

## TCC – Timer/Counter for Control Applications

### 49.8.21 Channel x Compare/Capture Buffer Value

**Name:** CCBUF  
**Offset:** 0x70 + n\*0x04 [n=0..5]  
**Reset:** 0x00000000  
**Property:** Write-Synchronized, Read-Synchronized

CCBUFx is copied into CCx at TCC update time

Bit	31	30	29	28	27	26	25	24
Access								
Reset								
Bit	23	22	21	20	19	18	17	16
	CCBUF[17:10]							
Access	R/W	R/W	R/W	R/W	R/W	R/W	R/W	R/W
Reset	0	0	0	0	0	0	0	0
Bit	15	14	13	12	11	10	9	8
	CCBUF[9:2]							
Access	R/W	R/W	R/W	R/W	R/W	R/W	R/W	R/W
Reset	0	0	0	0	0	0	0	0
Bit	7	6	5	4	3	2	1	0
	CCBUF[1:0]		DITHERBUF[5:0]					
Access	R/W	R/W	R/W	R/W	R/W	R/W	R/W	R/W
Reset	0	0	0	0	0	0	0	0

#### Bits 23:6 – CCBUF[17:0] Channel x Compare/Capture Buffer Value

These bits hold the value of the Channel x Compare/Capture Buffer Value register. The register serves as the buffer for the associated compare or capture registers (CCx). Accessing this register using the CPU or DMA will affect the corresponding CCBUFVx status bit.

**Note:**

1. When the TCC is configured as a 16-bit timer/counter, the excess bits are read as zero.
2. This bit field occupies the MSB of the register, [23:m]. m is dependent on the Resolution bit in the Control A register (CTRLA.RESOLUTION):

CTRLA.RESOLUTION	Bits [23:m]
0x0 - NONE	23:0
0x1 - DITH4	23:4
0x2 - DITH5	23:5
0x3 - DITH6	23:6 (depicted)

#### Bits 5:0 – DITHERBUF[5:0] Dithering Buffer Cycle Number

These bits represent the CCx.DITHER bits buffer. When the double buffering is enable, DITHERBUF bits value is copied to the CCx.DITHER bits on an UPDATE condition.

# SAM D5x/E5x Family Data Sheet

## TCC – Timer/Counter for Control Applications

**Note:** This bit field consists of the n LSB of the register. n is dependent on the value of the Resolution bits in the Control A register (CTRLA.RESOLUTION):

CTRLA.RESOLUTION	Bits [n:0]
0x0 - NONE	-
0x1 - DITH4	3:0
0x2 - DITH5	4:0
0x3 - DITH6	5:0 (depicted)

## 50. PTC - Peripheral Touch Controller

### 50.1 Overview

The Peripheral Touch Controller (PTC) acquires signals in order to detect a touch on the capacitive sensors. The external capacitive touch sensor is typically formed on a PCB, and the sensor electrodes are connected to the analog front end of the PTC through the I/O pins in the device. The PTC supports both self and mutual capacitance sensors.

In the Mutual Capacitance mode, sensing is done using capacitive touch matrices in various X-Y configurations, including indium tin oxide (ITO) sensor grids. The PTC requires one pin per X-line and one pin per Y-line.

In the Self Capacitance mode, the PTC requires only one pin (Y-line) for each touch sensor.

The number of available pins and the assignment of X- and Y-lines is depending on both package type and device configuration. Refer to the Configuration Summary and I/O Multiplexing table for details.

#### Related Links

[6. I/O Multiplexing and Considerations](#)

### 50.2 Features

- Low-Power, High-Sensitivity, Environmentally Robust Capacitive Touch Buttons, Sliders, and Wheels
- Supports Wake-up on Touch from sleep mode Sleep mode
- Supports Mutual Capacitance and Self Capacitance Sensing
  - Mix-and-Match Mutual and Self Capacitance Sensors
- One Pin per Electrode – No External Components
- Load Compensating Charge Sensing
  - Parasitic capacitance compensation and adjustable gain for superior sensitivity
- Zero Drift Over the Temperature and  $V_{DD}$  Range
  - Auto calibration and recalibration of sensors
- Single-shot and free-running Charge Measurement
- Hardware Noise Filtering and Noise Signal Desynchronization for High Conducted Immunity
- Selectable channel change delay allows choosing the settling time on a new channel, as required
- Acquisition-start triggered by command or through auto-triggering feature
- Low CPU utilization through interrupt on acquisition-complete
- Using ADC peripheral for signal conversion and acquisition

#### Related Links

[6. I/O Multiplexing and Considerations](#)

### 50.3 Block Diagram

Figure 50-1. PTC Block Diagram Mutual Capacitance

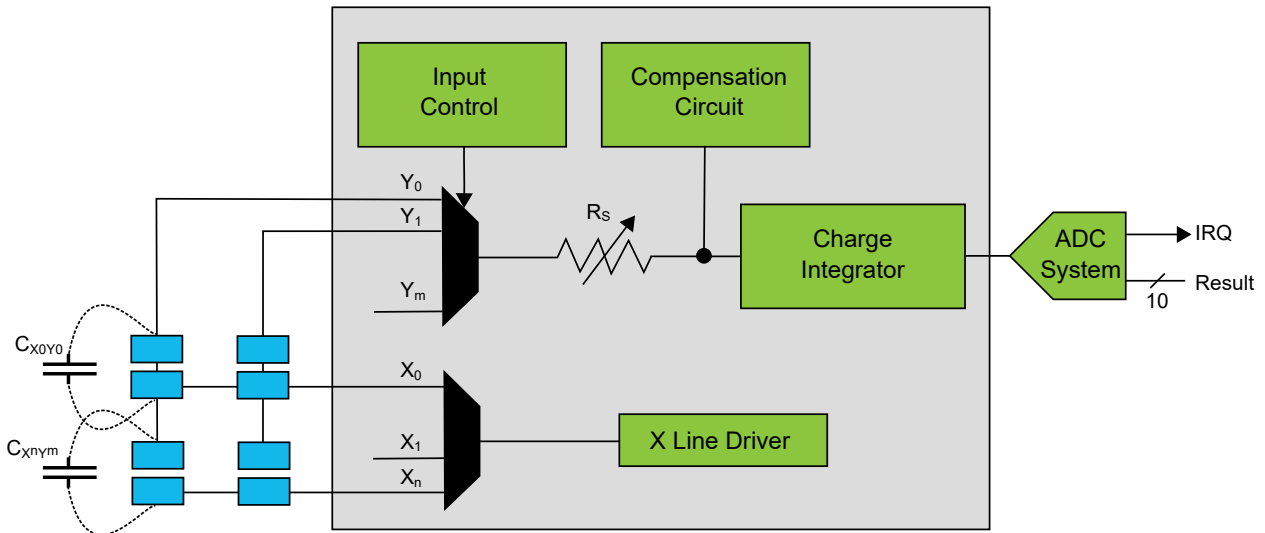
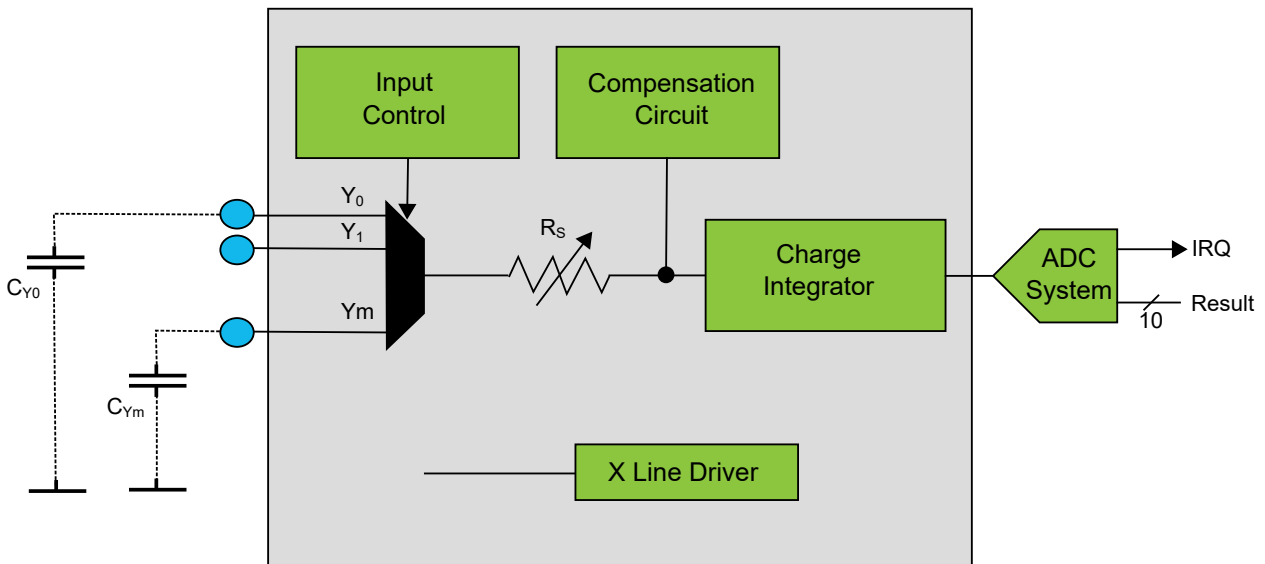


Figure 50-2. PTC Block Diagram Self Capacitance



### 50.4 Signal Description

Table 50-1. Signal Description for PTC

Name	Type	Description
Y[m:0]	Analog	Y-line (Input/Output)
X[n:0]	Digital	X-line (Output)

**Note:** The number of X- and Y-lines are device dependent. Refer to *Configuration Summary* for details.

Refer to *I/O Multiplexing and Considerations* for details on the pin mapping for this peripheral. One signal can be mapped on several pins.

### Related Links

[6. I/O Multiplexing and Considerations](#)

## 50.5 System Dependencies

In order to use this peripheral, configure the other components of the system as described in the following sections.

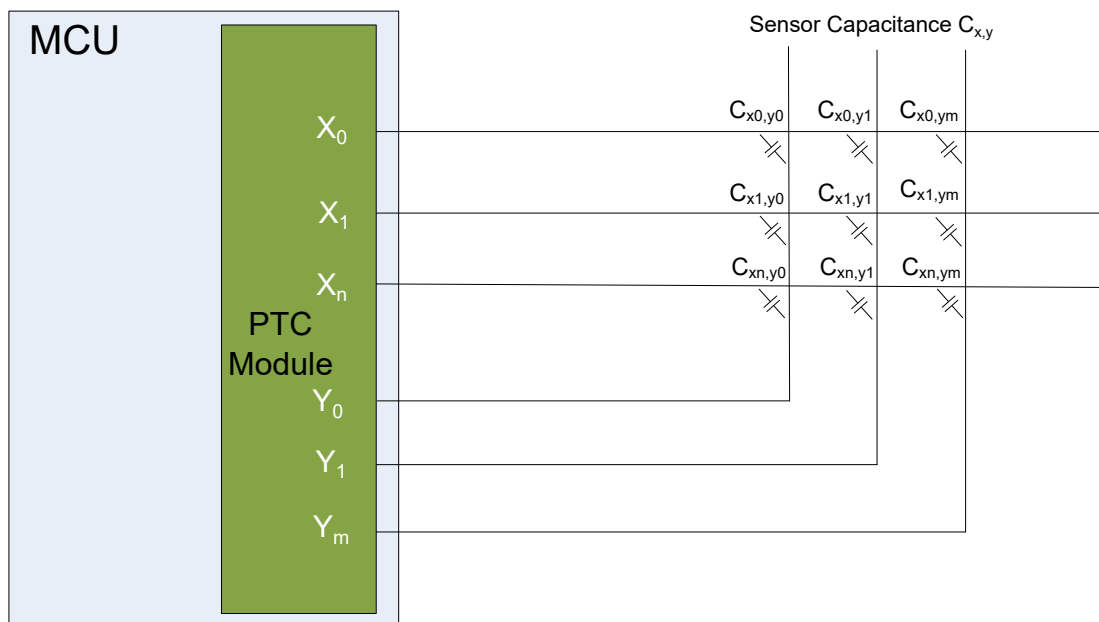
### 50.5.1 I/O Lines

The I/O lines used for analog X- and Y-lines must be connected to external capacitive touch sensor electrodes. External components are not required for normal operation. However, to improve the EMC performance, a series resistor of 1 kΩ or more can be used on X- and Y-lines.

#### 50.5.1.1 Mutual Capacitance Sensor Arrangement

A mutual capacitance sensor is formed between two I/O lines - an X electrode for transmitting and Y electrode for sensing. The mutual capacitance between the X and Y electrode is measured by the peripheral touch controller.

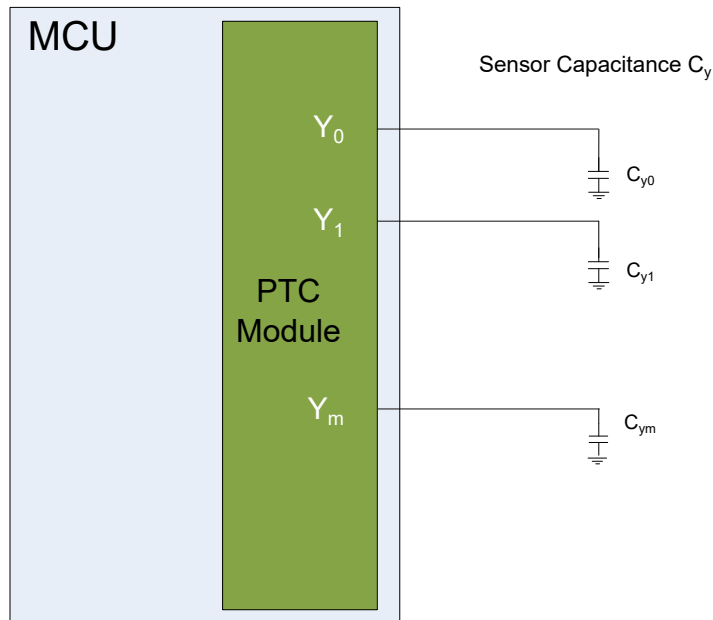
**Figure 50-3. Mutual Capacitance Sensor Arrangement**



#### 50.5.1.2 Self Capacitance Sensor Arrangement

A self capacitance sensor is connected to a single pin on the peripheral touch controller through the Y electrode for sensing the signal. The sense electrode capacitance is measured by the peripheral touch controller.

**Figure 50-4. Self-Capacitance Sensor Arrangement**



For more information about designing the touch sensor, refer to [Buttons, Sliders and Wheels Touch Sensor Design Guide](#).

### 50.5.2 Analog-Digital Converter (ADC)

The PTC is using the ADC for signal conversion and acquisition. The ADC must be enabled and configured appropriately to allow correct behavior of the PTC.

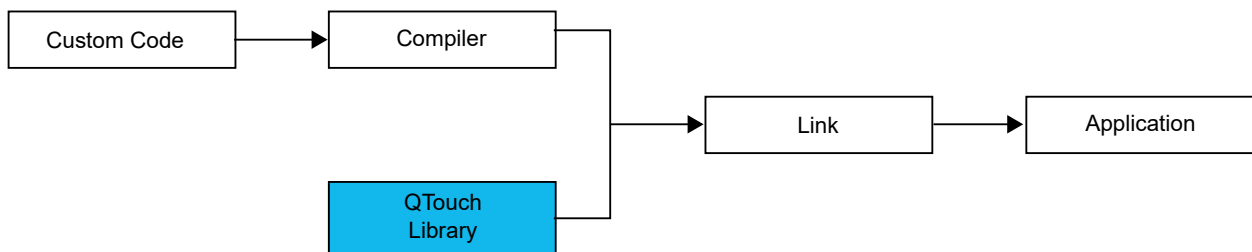
#### Related Links

[45. ADC – Analog-to-Digital Converter](#)

## 50.6 Functional Description

In order to access the PTC, the user must use the Atmel|START QTouch® Configurator to configure and link the QTouch Library firmware with the application software. QTouch Library can be used to implement buttons, sliders, and wheels in a variety of combinations on a single interface.

**Figure 50-5. QTouch Library Usage**



For more information about QTouch Library, refer to the [QTouch Library Peripheral Touch Controller User Guide](#).

## 51. I2S - Inter-IC Sound Controller

### 51.1 Overview

The Inter-IC Sound Controller (I<sup>2</sup>S) provides bidirectional, synchronous and digital audio link with external audio devices.

This controller is compliant with the Inter-IC Sound (I<sup>2</sup>S) bus specification. It supports TDM interface with external multi-slot audio codecs. It also supports PDM interface with external MEMS microphones.

The I<sup>2</sup>S consists of two Clock Units, one Transmit Serializer, and one Receive Serializer, that can be enabled separately, to provide Master, Slave, or controller modes.

The pins associated with I2S peripheral are SDO,SDI, FS<sub>n</sub>, SCK<sub>n</sub>, and MCK<sub>n</sub> pins.

Peripheral DMAC channels, separate for each Serializer, allow a continuous high bitrate data transfer without processor intervention to the following:

- Audio codecs in Master, Slave, or Controller mode
- Stereo DAC or ADC through dedicated I<sup>2</sup>S serial interface
- Multi-slot or multiple stereo DACs or ADCs, using the TDM format
- Mono or stereo MEMS microphones, using the PDM interface

Each Serializer supports using either a single DMAC channel for all data channels, or two separate DMAC channels for different data channels.

The I<sup>2</sup>S supports 8-bit and 16-bit compact stereo format. This helps in reducing the required DMA bandwidth by transferring the left and right samples within the same data word.

Usually, an external audio codec or digital signal processor (DSP) requires a clock which is a multiple of the sampling frequency  $f_s$  (for example,  $384 \times f_s$ ). The I<sup>2</sup>S peripheral in Master Mode and Controller mode is capable of outputting an output clock ranging from  $16 \times f_s$  to  $1024 \times f_s$  on the Master Clock pin (MCK<sub>n</sub>). The Master Clock pin cannot output a clock signal when in Slave Mode.

### 51.2 Features

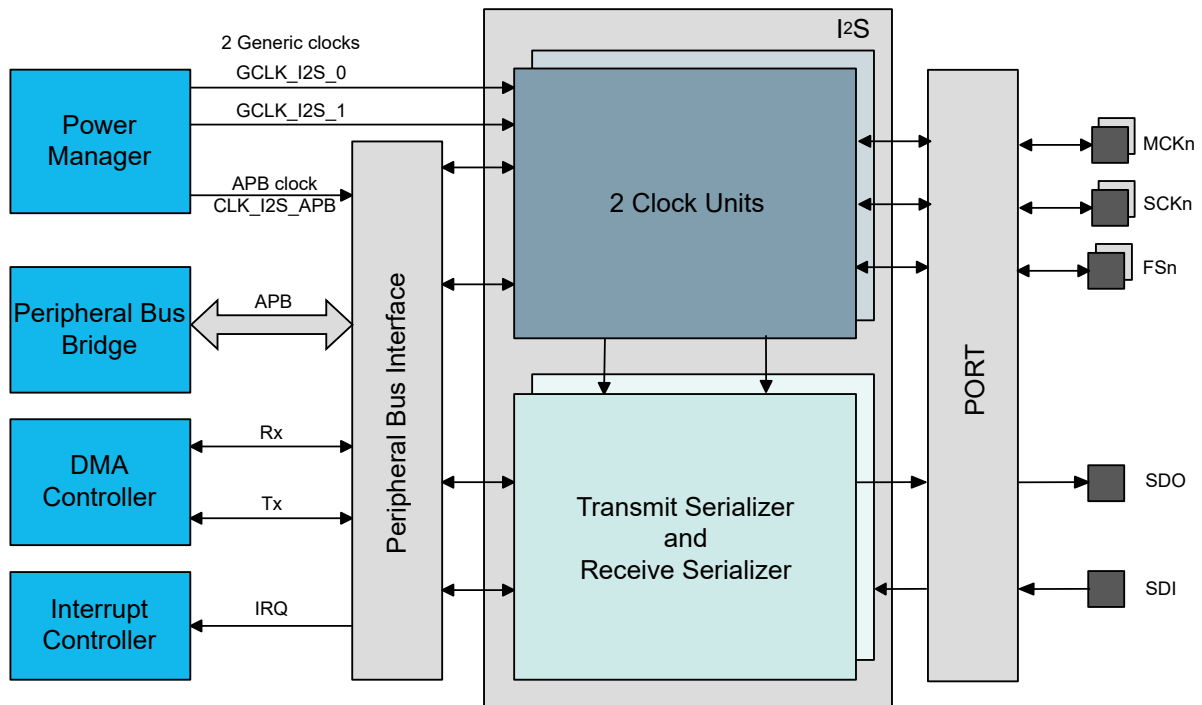
- Compliant with Inter-IC Sound (I<sup>2</sup>S) bus specification
- Supported data formats:
  - 32-, 24-, 20-, 18-, 16-, and 8-bit mono or stereo format
  - 16- and 8-bit compact stereo format, with left and right samples packed in the same word to reduce data transfers
- Supported data frame formats:
  - 2-channel I<sup>2</sup>S with Word Select
  - 1- to 8-slot Time Division Multiplexed (TDM) with Frame Sync and individually enabled slots
  - 1- or 2-channel Pulse Density Modulation (PDM) reception for MEMS microphones
  - 1-channel burst transfer with non-periodic Frame Sync
- 2 independent Clock Units handling either the same clock or separate clocks for the Serializers:
  - Suitable for a wide range of sample frequencies  $f_s$ , including 32kHz, 44.1kHz, 48kHz, 88.2kHz, 96kHz, and 192kHz
  - $16 \times f_s$  to  $1024 \times f_s$  Master Clock generated for external audio CODECs



- Master, slave, and controller modes:
  - Master: Data received/transmitted based on internally-generated clocks. Output Serial Clock on SCKn pin, Master Clock on MCKn pin, and Frame Sync Clock on FSn pin
  - Slave: Data received/transmitted based on external clocks on Serial Clock pin (SCKn) or Master Clock pin (MCKn)
  - Controller: Only output internally generated Master clock (MCKn), Serial Clock (SCKn), and Frame Sync Clock (FSn)
- Individual enabling and disabling of Clock Units and Serializers
- DMA interfaces for each Serializer receiver or transmitter to reduce processor overhead:
  - Either one DMA channel for all data slots or
  - One DMA channel per data channel in stereo
- Smart Data Holding register management to avoid data slots mix after overrun or underrun

### 51.3 Block Diagram

Figure 51-1. I<sup>2</sup>S Block Diagram



### 51.4 Signal Description

Table 51-1.

Pin Name	Pin Description	Type
MCKn	Master Clock for Clock Unit n	Input/Output
SCKn	Serial Clock for Clock Unit n	Input/Output
FSn	I <sup>2</sup> S Word Select or TDM Frame Sync for Clock Unit n	Input/Output

.....continued		
Pin Name	Pin Description	Type
SDO	Serial Data Output for Transmit Serializer	Output
SDI	Serial Data Input for Receive Serializer	Input

**Note:** One signal can be mapped on several pins.

### Related Links

[6. I/O Multiplexing and Considerations](#)

## 51.5 Product Dependencies

In order to use this module, other parts of the system must be configured correctly, as described below.

### 51.5.1 I/O Lines

Using the I<sup>2</sup>S I/O lines requires the I/O pins to be configured.

The I<sup>2</sup>S pins may be multiplexed with I/O Controller lines. The user must first program the I/O Controller to assign the desired I<sup>2</sup>S pins to their peripheral function. If the I<sup>2</sup>S I/O lines are not used by the application, they can be used for other purposes by the I/O Controller. It is required to enable only the I<sup>2</sup>S inputs and outputs actually in use.

### Related Links

[32. PORT - I/O Pin Controller](#)

### 51.5.2 Power Management

The I<sup>2</sup>S will continue to operate in any sleep mode where the selected source clocks are running.

### 51.5.3 Clocks

The clock for the I<sup>2</sup>S bus interface (CLK\_I2S\_APB) is generated by the Power Manager. This clock is disabled at reset, and can be enabled in the Power Manager. It is recommended to disable the I<sup>2</sup>S before disabling the clock, to avoid freezing the I<sup>2</sup>S in an undefined state.

There are two generic clocks, GCLK\_I2S\_0 and GCLK\_I2S\_1, connected to the I<sup>2</sup>S peripheral, one for each I<sup>2</sup>S clock unit. The generic clocks (GCLK\_I2S\_n, n=0..1) can be set to a wide range of frequencies and clock sources. The GCLK\_I2S\_n must be enabled and configured before use.

The GCLK\_I2S\_n clocks must be enabled and configured before triggering Software Reset, so that the logic in all clock domains can be reset.

The generic clocks are only used in Master mode and Controller mode. In Master mode, the clock from clock unit 0 can be used for both Serializers to handle synchronous transfers, or a separate clock from different clock units can be used for each Serializer to handle transfers on non-related clocks.

### Related Links

[14. GCLK - Generic Clock Controller](#)

### 51.5.4 DMA

The DMA request lines are connected to the DMA Controller (DMAC). Using the I<sup>2</sup>S DMA requests requires the DMA Controller to be configured first.

### Related Links

### 22. DMAC – Direct Memory Access Controller

#### 51.5.5 Interrupts

The interrupt request line is connected to the interrupt controller. Using I<sup>2</sup>S interrupts requires the interrupt controller to be configured first.

##### Related Links

[10.2 Nested Vector Interrupt Controller](#)

#### 51.5.6 Events

Not applicable.

#### 51.5.7 Debug Operation

When the CPU is halted in Debug mode, this peripheral will continue normal operation. If the peripheral is configured to require periodical service by the CPU through interrupts or similar, improper operation or data loss may result during debugging. This peripheral can be forced to halt operation during debugging.

#### 51.5.8 Register Access Protection

Registers with write access can be optionally write-protected by the Peripheral Access Controller (PAC), except for the following:

- DATAm
- INTFLAG
- SYNCBUSY

**Note:** Optional write protection is indicated by the "PAC Write Protection" property in the register description.

Write protection does not apply for accesses through an external debugger.

#### 51.5.9 Analog Connections

Not applicable.

### 51.6 Functional Description

#### 51.6.1 Principle of Operation

The I<sup>2</sup>S uses three or four communication lines for synchronous data transfer:

- SDO output for Transmit Serializer
- SDI input for Receive Serializer
- SCKn for the serial clock in Clock Unit n (n=0..1)
- FSn for the frame synchronization or I<sup>2</sup>S word select, identifying the beginning of each frame
- Optionally, MCKn to output an oversampling clock to an external codec

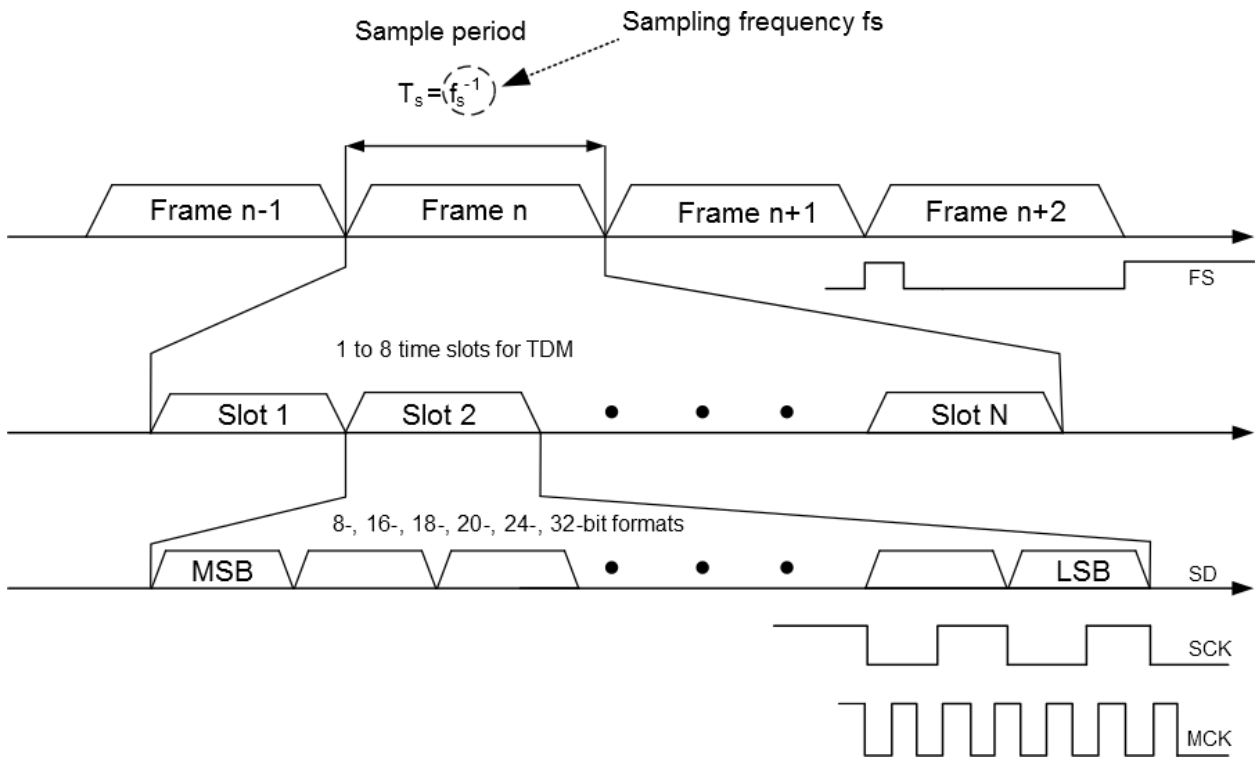
I<sup>2</sup>S data transfer is frame based, where a serial frame:

- Starts with the frame synchronization active edge, and
- Consists of 1 to 8 data slots, that are 8-, 16-, 24-, or 32-bit wide.

Each data slot is used to transfer one data sample of 8, 16, 18, 20, 24 or 32 bits.

Frame based data transfer is described in the following figure:

**Figure 51-2. Data Format: Frames, Slot, Bits and Clocks**



I<sup>2</sup>S supports multiple data formats such as:

- 32-, 24-, 20-, 18-, 16-, and 8-bit mono or stereo format
- 16- and 8-bit compact stereo format, with left and right samples packed in the same word to reduce data transfers

In mono format, Transmit mode, data written to the left channel is duplicated to the right output channel. In mono format, Receiver mode, data received from the right channel is ignored and data received from the left channel is duplicated in to the right channel.

In mono format, TDM Transmit mode with more than two slots, data written to the even-numbered slots is duplicated in to the following odd-numbered slot.

In mono format, TDM Receiver mode with more than two slots, data received from the even-numbered slots is duplicated in to the following odd-numbered slot.

Mono format can be enabled by writing a '1' to the MONO bit in the Serializer m Control register (SERCTRLm.MONO).

I<sup>2</sup>S support different data frame formats:

- 2-channel I<sup>2</sup>S with Word Select
- 1- to 8-slot Time Division Multiplexed (TDM) with Frame Sync and individually enabled slots
- 1- or 2-channel Pulse Density Modulation (PDM) reception for MEMS microphones
- 1-channel burst transfer with non-periodic Frame Sync

In 2 channel I<sup>2</sup>S mode, number of slots configured is one or two and successive data words corresponds to left and right channel. Left and right channel are identified by polarity of Word Select signal (FSn signal). Each frame consists of one or two data word(s). In the case of compact stereo format, the number of slots can be one. When 32-bit slot size is used, the number of slots can be two.

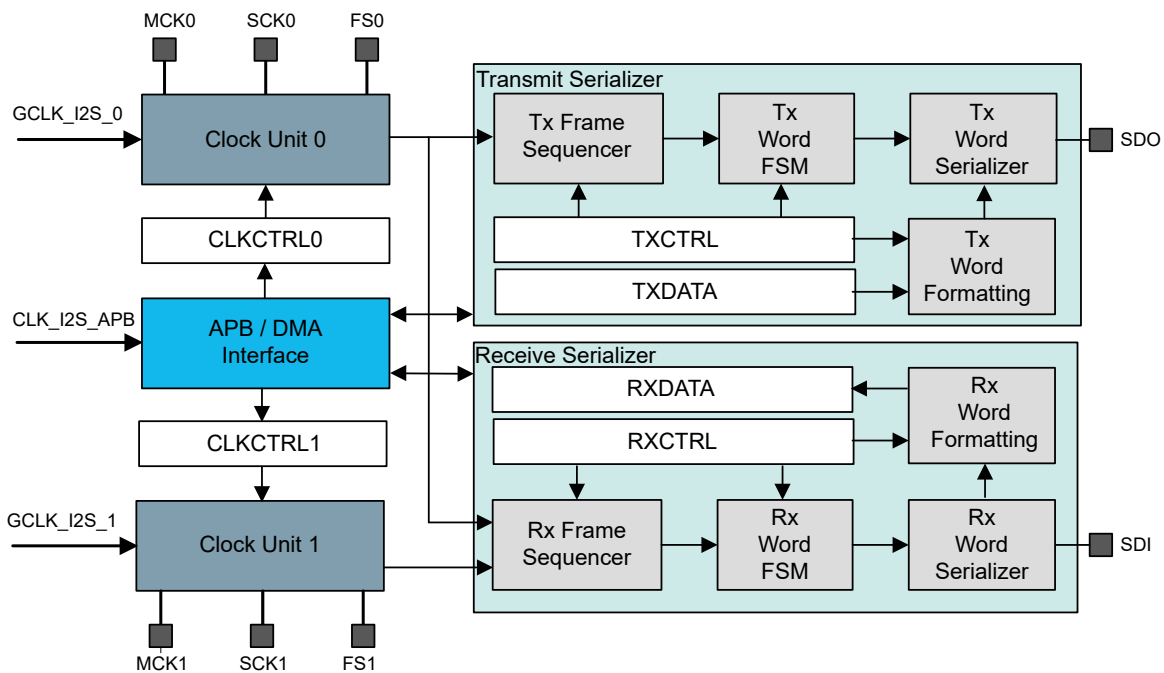
In TDM format, number slots can be configured up to 8 slots. If 4 slots are configured, each frame consists of 4 data words.

In PDM format, continuous 1-bit data samples are available on the SDI line for each SCK<sub>n</sub> rising and SCK<sub>n</sub> falling edge as in case of a MEMS microphone with PDM interface.

1-channel burst transfer with non-periodic Frame Sync mode is useful typically for passing control non-auto data as in case of DSP. In Burst mode, a single Data transfer starts at each Frame Sync pulse, and these pulses are 1-bit wide and occur only when a Data transfer is requested.

Sections [51.6.4 I<sup>2</sup>S Format - Reception and Transmission Sequence with Word Select](#), [51.6.5 TDM Format - Reception and Transmission Sequence](#) and [51.7 I<sup>2</sup>S Application Examples](#) describe more about frame/data formats and register settings required for different I<sup>2</sup>S applications.

**Figure 51-3. I<sup>2</sup>S Functional Block Diagram**



### 51.6.1.1 Initialization

The I<sup>2</sup>S features two Clock Units, one Transmit Serializer, and One Receive Serializer. The Transmit Serializer uses Clock Unit 0, while the Receive Serializer can either share the same Clock Unit 0 or use the Clock Unit 1.

Before enabling the I<sup>2</sup>S, the following registers must be configured:

- Clock Control registers (CLKCTRL<sub>n</sub>)
- Serializer Control registers (TXCTRL and/or RXCTRL)

In Master mode, one of the generic clocks for the I<sup>2</sup>S must also be configured to operate at the required frequency, as described in [51.6.1 Principle of Operation](#).

- $f_s$  is the sampling frequency that defines the frame period
- CLKCTRL<sub>n</sub>.NBSLOTS defines the number of slots in each frame
- CLKCTRL<sub>n</sub>.SLOTSIZE defines the number of bits in each slot
- SCK<sub>n</sub> frequency must be  $f_{SCKn} = f_s \times \text{number\_of\_slots} \times \text{number\_of\_bits\_per\_slot}$

Once the configuration has been written, the I<sup>2</sup>S Clock Units and Serializers can be enabled by writing a '1' to the CKENn, TXEN, and/or RXEN bits and to the ENABLE bit in the Control register (CTRLA). The Clock Unit n can be enabled alone, in Controller Mode, to output clocks to the MCKn, SCKn, and FSn pins. The Clock Units must be enabled if Serializers are enabled.

The Clock Units, the Transmit Serializer and the Receive Serializer can be disabled independently by writing a '0' to CTRLA.CKENn, CTRLA.TXEN, and CTRLA.RXEN, respectively. Once requested to stop, they will only stop when the pending transmit frames will be completed, if any. When requested to stop, the ongoing reception of the current slot will be completed and then the Serializer will be stopped.

**Example 51-1. Example Requirements:  $f_s=48\text{kHz}$ ,  $\text{MCKn}=384 \times f_s$**

If a  $384 \times f_s$  MCKn Master Clock is required (i.e. 18.432MHz), the I<sup>2</sup>S generic clock could run at 18.432MHz with a Master Clock Output Division Factor of 1 (selected by writing CLKCTRLn.MCKOUTDIV=0x0) in order to obtain the desired MCKn frequency.

When using 6 slots per frame (CLKCTRLn.NBSLOTS=0x5) and 32-bit slots (CLKCTRLn.SLOTSIZE=0x3), the desired SCKn frequency is

$$f_{\text{SCKn}} = 48\text{kHz} \times 6 \times 32 = 9.216\text{MHz}$$

This frequency can be achieved by dividing the I<sup>2</sup>S generic clock output of 18.432MHz by factor 2: Writing CLKCTRLn.MCKDIV=0x1 will select the correct division factor and output the desired SCKn frequency of 9.216MHz to the SCKn pin.

If MCKn is not required, the generic clock could be set to 9.216MHz and CLKCTRLn.MCKDIV=0x0.

### 51.6.2 Basic Operation

The Receiver can be operated by reading the Receive Data Holding register (RXDATA), whenever the Receive Ready m bit in the Interrupt Flag Status and Clear register (INTFLAG.RXRDYm) is set. Successive values read from the RXDATA register will correspond to the samples from the left and right audio channels. In TDM mode, the successive values read from RXDATA correspond to the first slot to the last slot. For instance, if I<sup>2</sup>S is configured in TDM mode with 4 slots in a frame, then successive values written to RXDATA register correspond to first, second, third, and fourth slot. The number of slots in TDM is configured in CLKCTRLn.NBSLOTS.

The Transmitter can be operated by writing to the Transmit Data Holding register (TXDATA), whenever the Transmit Ready m bit in the Interrupt Flag Status and Clear register (INTFLAG.TXRDYm) is set. Successive values written to TXDATA register should correspond to the samples from the left and right audio channels. In TDM mode, the successive values written to TXDATA correspond to the first, second, third, slot to the last slot. The number of slots in TDM is configured in CLKCTRLn.NBSLOTS.

The Receive Ready and Transmit Ready bits can be polled by reading the INTFLAG register.

The processor load can be reduced by enabling interrupt-driven operation. The RXRDYm and/or TXRDYm interrupt requests can be enabled by writing a '1' to the corresponding bit in the Interrupt Enable register (INTENSET). The interrupt service routine associated to the I<sup>2</sup>S interrupt request will then be executed whenever Receive Ready or Transmit Ready status bits are set.

The processor load can be reduced further by enabling DMA-driven operation. Then, the DMA channels support up to four trigger sources from the I<sup>2</sup>S peripheral. These four trigger sources in DMAC channel are

- I2S RX 0,

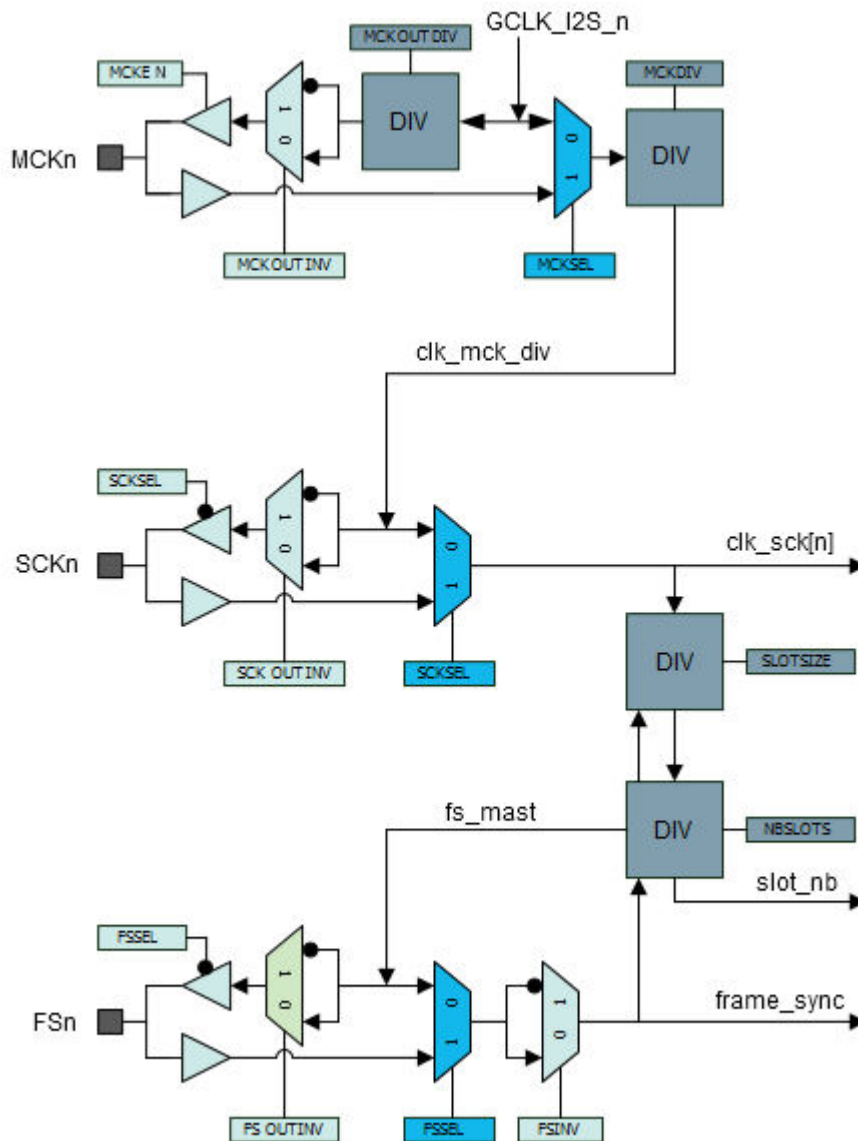
- I2S RX 1,
- I2S TX 0, and
- I2S TX 1.

For further reference, these are called I2S\_DMACH\_ID\_RX\_m and I2S\_DMACH\_ID\_TX\_m triggers (m=0..1). By using these trigger sources, one DMA data transfer will be executed whenever the Receive Ready or Transmit Ready status bits are set.

### 51.6.2.1 Master Clock, Serial Clock, and Frame Sync Generation

The generation of clocks in the I<sup>2</sup>S is described in the next figure.

**Figure 51-4. I<sup>2</sup>S Clocks Generation**



#### 51.6.2.1.1 Slave Mode

In Slave mode, the Serial Clock and Frame Sync (Word Select in I<sup>2</sup>S mode and Frame Sync in TDM mode) are driven by an external master. SCKn and FSn pins are inputs and no generic clock is required by the I<sup>2</sup>S.

### 51.6.2.1.2 Master Mode and Controller Mode

In Master Mode, the Master Clock (MCKn), the Serial Clock (SCKn), and the Frame Sync Clock (FSn) are generated by the I<sup>2</sup>S controller. The user can configure the Master Clock, Serial Clock, and Word Select Frame Sync signal (Word Select in I<sup>2</sup>S mode and Frame Sync in TDM mode) using the Clock Unit n Control register (CLKCTRLn). MCKn, SCKn, and FSn pins are outputs and a generic clock is used to derive the I<sup>2</sup>S clocks.

In some applications, audio CODECs connected to the I<sup>2</sup>S pins may require a Master Clock signal with a frequency multiple of the audio sample frequency  $f_s$ , such as  $256 \times f_s$ .

In Controller mode, only the Clock generation unit needs to be configured by writing to the CTRLA and CLKCTRLn registers, where parameters such as clock division factors, Number of slots, Slot size, Frame Sync signal, clock enable are selected.

### 51.6.2.1.3 MCKn Clock Frequency

When the I<sup>2</sup>S is in Master mode, writing a '1' to CLKCTRLn.MCKEN will output GCLK\_I2S\_n as Master Clock to the MCKn pin. The Master Clock to MCKn pin can be divided by writing to CLKCTRLn.MCKSEL and CLKCTRLn.MCKOUTDIV. The Master Clock (MCKn) frequency is GCLK\_I2S\_n frequency divided by (MCKOUTDIV+1).

$$f(\text{MCKn}) = \frac{f(\text{GCLK\_I2S\_n})}{(\text{MCKOUTDIV}+1)}$$

### 51.6.2.1.4 SCKn Clock Frequency

When the Serial Clock (SCKn) is generated from GCLK\_I2S\_n and both CLKCTRLn.MCKSEL and CLKCTRLn.SCKSEL are zero, the Serial Clock (SCKn) frequency is GCLK\_I2S\_n frequency divided by (MCKDIV+1).

i.e.

$$f(\text{SCKn}) = \frac{f(\text{GCLK\_I2S\_n})}{(\text{MCKDIV}+1)}$$

### 51.6.2.1.5 Relation Between MCKn, SCKn, and Sampling Frequency $f_s$

Based on sampling frequency  $f_s$ , the SCKn frequency requirement can be calculated:

- SCKn frequency:  $f_{\text{SCKn}} = f_s \times \text{total\_number\_of\_bits\_per\_frame}$ ,
- Where  $\text{total\_number\_of\_bits\_per\_frame} = \text{number\_of\_slots} \times \text{number\_of\_bits\_per\_slots}$ .
- The number of slots is selected by writing to the Number of Slots in Frame bit field in the Clock Unit n Control (CLKCTRLn) register:  $\text{number\_of\_slots} = \text{NBSLOTS} + 1$ .
- The number of bits per slot (8, 16, 24, or 32 bit) is selected by writing to the Slot Size bit field in CLKCTRLn: .
- Consequently,  $f_{\text{SCKn}} = 8 \times f_s \times (\text{NBSLOTS} + 1) \times (\text{SLOTSIZE} + 1)$ .

The clock frequencies  $f_{\text{SCKn}}$  and  $f_{\text{MCKn}}$  are derived from the generic clock frequency  $f_{\text{GCLK\_I2S\_n}}$  :

$$\begin{aligned} f_{\text{GCLK\_I2S\_n}} &= f_{\text{SCKn}} \times (\text{CLKCTRLn.MCKDIV} + 1) \\ &= 8 \times f_s \times (\text{NBSLOTS} + 1) \times (\text{SLOTSIZE} + 1) \times (\text{MCKDIV} + 1) \end{aligned}$$

, and

$$f_{\text{GCLK\_I2S\_n}} = f_{\text{MCKn}} \times (\text{MCKOUTDIV} + 1).$$

Substituting the right hand sides of the two last equations yields:

$$f_{\text{MCKn}} = \frac{f_{\text{GCLK\_I2S\_n}}}{\text{MCKOUTDIV}+1}$$



$$f_{\text{MCKn}} = \frac{8 \cdot (\text{SLOTSIZE}+1) \cdot (\text{NBSLOTS}+1) \cdot (\text{MCKDIV}+1)}{\text{MCKOUTDIV}+1}$$

If a Master Clock output is not required, the GCLK\_I2S generic clock can be configured as SCKn by writing a '0' to CLKCTRLn.MCKDIV. Alternatively, if the frequency of the generic clock is a multiple of the required SCKn frequency, the MCKn-to-SCKn divider can be used with the ratio defined by writing the CLKCTRLn.MCKDIV field.

The FSn pin is used as Word Select in I<sup>2</sup>S format and as Frame Synchronization in TDM format, as described in [51.6.4 I2S Format - Reception and Transmission Sequence with Word Select](#) and [51.6.5 TDM Format - Reception and Transmission Sequence](#), respectively.

### 51.6.2.2 Data Holding Registers

For both the Transmit and the Receive Serializer, the I<sup>2</sup>S user interface includes a Data register (TXDATA and RXDATA, respectively). They are used to access data samples for all data slots.

#### 51.6.2.2.1 Data Reception Mode

In receiver mode, the RXDATA register stores the received data.

When a new data word is available in the RXDATA register, the Receive Ready bit (RXRDYm) in the Interrupt Flag Status and Clear register (INTFLAG) is set. Reading the RXDATA register will clear this bit.

A receive overrun condition occurs if a new data word becomes available before the previous data word has been read from the RXDATA register. Then, the Receive Overrun bit in INTFLAG will be set (INTFLAG.RXORM). This interrupt can be cleared by writing a '1' to it.

#### 51.6.2.2.2 Data Transmission Mode

In Transmitter mode, the TXDATA register contains the data to be transmitted.

when TXDATA is empty, the Transmit Ready bit in the Interrupt Flag Status and Clear register is set (INTFLAG.TXRDYm). Writing to TXDATA will clear this bit.

A transmit underrun condition occurs if data present in TXDATA is sent and no new data is written to TXDATA register before the next time slot. Then, the Transmit Underrun bit in INTFLAG will be set (INTFLAG.TXURm). This interrupt can be cleared by writing a '1' to it. The Transmit Data when Underrun bit in the Tx Serializer Control register (TXCTRL.TXSAME) configures whether a zero data word is transmitted in case of underrun (TXCTRL.TXSAME=0), or the previous data word for the current transmit slot number is transmitted again (TXCTRL.TXSAME=1).

### 51.6.3 Master, Controller, and Slave Modes

In Master and Controller modes, the I<sup>2</sup>S provides the Serial Clock, a Word Select/Frame Sync signal and optionally a Master Clock.

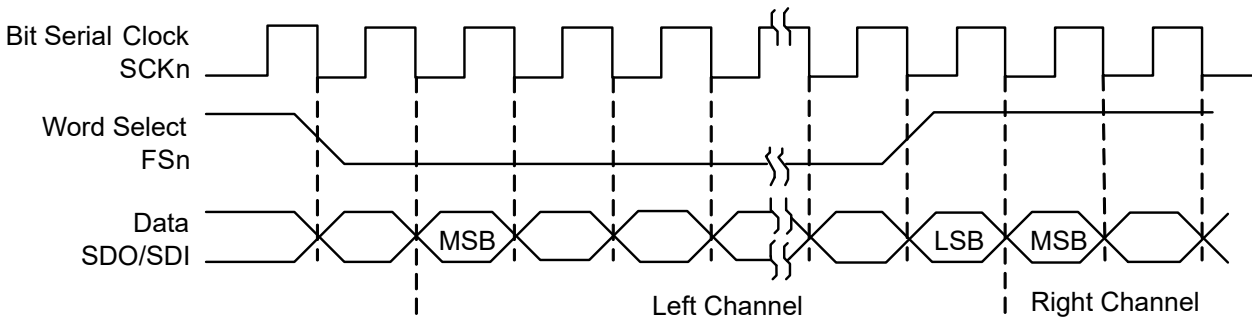
In Controller mode, the I<sup>2</sup>S Serializers are disabled. Only the clocks are enabled and output for external receivers and/or transmitters.

In Slave mode, the I<sup>2</sup>S receives the Serial Clock and the Word Select/Frame Sync Signal from an external master. SCKn and FSn pins are inputs.

### 51.6.4 I<sup>2</sup>S Format - Reception and Transmission Sequence with Word Select

As specified in the I<sup>2</sup>S protocol, data bits are left-adjusted in the Word Select slot, with the MSB transmitted first, starting one clock period after the transition on the Word Select line.

**Figure 51-5. I<sup>2</sup>S Reception and Transmission Sequence**



Data bits are sent on the falling edge of the Serial Clock and sampled on the rising edge of the Serial Clock. The Word Select line indicates the channel in transmission, a low level for the left channel and a high level for the right channel.

In I<sup>2</sup>S format, typical configurations are described below. These configurations do not list all necessary settings, but only basic ones. Other configuration settings are to be done as per requirement such as clock and DMA configurations.

### Case 1: I<sup>2</sup>S 16-bit compact stereo receiver

- Slot size configured as 16 bits (CLKCTRL0.SLOTSIZE = 0x1)
- Number of slots configured as 2 (CLKCTRL0.NBSLOTS = 0x1)
- Data size configured as 16-bit compact stereo (RXCTRL.DATASIZE = 0x05)
- Data delay from Frame Sync configured as 1-bit delay (CLKCTRLn.BITDELAY = 0x01)
- Frame Sync Width configured as HALF frame (CLKCTRLn.FSWIDTH = 0x01)

### Case 2: I<sup>2</sup>S 24-bit stereo Transmitter with 24-bit slot

- Slot size configured as 24 bits (CLKCTRL0.SLOTSIZE = 0x2)
- Number of slots configured as 2 (CLKCTRL0.NBSLOTS = 0x1)
- Data size configured as 24 bits (TXCTRL.DATASIZE = 0x01)
- Data delay from Frame Sync configured as 1-bit delay (CLKCTRLn.BITDELAY = 0x01)
- Frame Sync Width configured as HALF frame (CLKCTRLn.FSWIDTH = 0x01)

In both cases, it will ensure that Word select signal is 'low level' for the left channel and 'high level' for the right channel.

The length of transmitted words can be chosen among 8, 16, 18, 20, 24, and 32 bits by writing the Data Word Size bit group in the Serializer Control register (RXCTRL.DATASIZE or TXCTRL.DATASIZE, respectively).

If the slot allows for more data bits than the number of bits specified in the respective DATASIZE field, additional bits are appended to the transmitted or received data word as specified in the RXCTRL/TXCTRL.EXTEND field. If the slot allows less data bits than programmed, the extra bits are not transmitted, or received data word is extended based on the EXTEND field value.

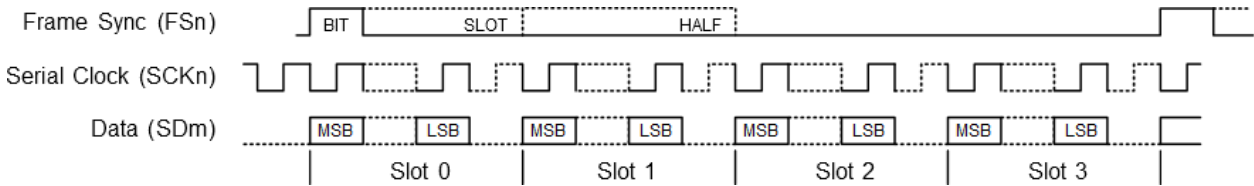
### 51.6.5 TDM Format - Reception and Transmission Sequence

In Time Division Multiplexed (TDM) format, the number of data slots sent or received within each frame will be (CLKCTRLn.NBSLOTS + 1).

By configuring the CLKCTRLn register (CLKCTRLn.FSWIDTH and CLKCTRLn.FSINV), the Frame Sync pulse width and polarity can be modified.

By configuring RXCTRL and/or TXCTRL, data bits can be left-adjusted or right-adjusted in the slot. It can also configure the data transmission/reception with either the MSB or the LSB transmitted/received first and starting the transmission/reception either at the transition of the FS<sub>n</sub> pin or one clock period after.

**Figure 51-6. TDM Format Reception and Transmission Sequence**



Data bits are sent on the falling edge of the Serial Clock and sampled on the rising edge of the Serial Clock. The FS<sub>n</sub> pin provides a frame synchronization signal, at the beginning of slot 0. The delay between the frame start and the first data bit is defined by writing the CLKCTRL<sub>n</sub>.BITDELAY field.

The Frame Sync pulse can be either one SCK<sub>n</sub> period (BIT), one slot (SLOT), or one half frame (HALF). This selection is done by writing the CLKCTRL<sub>n</sub>.FSWIDTH field.

The number of slots is selected by writing the CLKCTRL<sub>n</sub>.NBSLOTS field.

The number of bits in each slot is selected by writing the CLKCTRL<sub>n</sub>.SLOTSIZE field.

The length of transmitted words can be chosen among 8, 16, 18, 20, 24, and 32 bits by writing the DATASIZE field in the Serializer Control register (RXCTRL and/or TXCTRL).

If the slot allows more data bits than the number of bits specified in the RXCTRL. and/or TXCTRL.DATASIZE bit field, additional bits are appended to the transmitted or received data word as specified in the RXCTRL. and/or TXCTRL.EXTEND bit field. If the slot allows less data bits than programmed, the extra bits are not transmitted, or received data word is extended based on the EXTEND field value.

### 51.6.6 PDM Reception

In Pulse Density Modulation (PDM) reception mode, continuous 1-bit data samples are available on the SDI line on each SCK<sub>n</sub> rising edge, e.g. by a MEMS microphone with PDM interface. When using two channel PDM microphones, the second one (right channel) is configured to output data on each SCK<sub>n</sub> falling edge.

For one PDM microphone, the I<sup>2</sup>S controller should be configured in normal Receive mode with one slot and 16- or 32-bit data size, so that 16 or 32 samples of the microphone are stored into each data word.

For two PDM microphones, the I<sup>2</sup>S controller should be configured in PDM2 mode with one slot and 32-bit data size. The Rx Serializer will store 16 samples of each microphone in one half of the data word, with left microphone bits in lower half and right microphone bits in upper half, like in compact stereo format.

Based on oversampling frequency requirement from PDM microphone, the SCK<sub>n</sub> frequency must be configured in the I<sup>2</sup>S controller.

A microphone that requires a sampling frequency of  $f_s = 48$  kHz and an oversampling frequency of  $f_o = 64 \times f_s$  would require an SCK<sub>n</sub> frequency of 3.072 MHz.

After selecting a proper frequency for GCLK\_I2S<sub>n</sub> and according Master Clock Division Factor in the Clock Unit n Control register (CLKCTRL<sub>n</sub>.MCKDIV), SCK<sub>n</sub> must be selected as per required frequency.

In PDM mode, only the clock and data line (SCK<sub>n</sub> and SDI<sub>n</sub>) pins are used.

To configure PDM2 mode, set SLOTSIZE = 0x01 (16-bits), NBSLOTS = 0x00 (1 slots) and RXCTRL.DATASIZE = 0x00 (32-bit).

### 51.6.7 Data Formatting Unit

To allow more flexibility, data words received by the Receive Serializer will be formatted by the Receive Formatting Unit before being stored into the Data Holding register (DATAm). The data words written into DATAm register will be formatted by the Transmit Formatting Unit before transmission by the Transmit Serializer .

The formatting options are defined in RXCTRL and TXCTRL:

- SLOTADJ for left or right justification in the slot
- BITREV for bit reversal
- WORDADJ for left or right justification in the data word
- EXTEND for extension to the word size

### 51.6.8 DMA, Interrupts and Events

**Table 51-2. Module Request for I<sup>2</sup>S**

Condition	DMA request	DMA request is cleared	Interrupt request	Event input/output
Receive Ready	YES	When data is read	YES	
Transmit Ready (Buffer empty)	YES	When data is written	YES	
Receive Overrun			YES	
Transmit Underrun			YES	

#### 51.6.8.1 DMA Operation

Each Serializer can be connected either to one single DMAC channel or to one DMAC channel per data slot in Stereo mode. This is selected by writing the RXCTRL/TXCTRL.DMA bit.

**Table 51-3. I<sup>2</sup>C DMA Request Generation**

SERCTRLm.DMA	Mode	Slot Parity	DMA Request Trigger
0	Receiver	all	I2S_DMACH_ID_RX_m
	Transmitter	all	I2S_DMACH_ID_TX_m
1	Receiver	even	I2S_DMACH_ID_RX_m
		odd	I2S_DMACH_ID_TX_m
	Transmitter	even	I2S_DMACH_ID_TX_m
		odd	I2S_DMACH_ID_RX_m

The DMAC reads from the RXDATA register and writes to the TXDATA register for all data slots, successively.

The DMAC transfers may use 32-bit, 16-bit, or or 8-bit transactions according to the value of the TXCTRL/RXCTRL.DATASIZE field. 8-bit compact stereo uses 16-bit and 16-bit compact stereo uses 32-bit transactions.

### 51.6.8.2 Interrupts

The I<sup>2</sup>S has the following interrupt sources:

- Receive Ready (RXRDYm): This is an asynchronous interrupt and can be used to wake-up the device from any sleep mode.
- Receive Overrun (RXORM): This is an asynchronous interrupt and can be used to wake-up the device from any sleep mode.
- Transmit Ready (TXRDYm): This is an asynchronous interrupt and can be used to wake-up the device from any sleep mode.
- Transmit Underrun (TXURm): This is an asynchronous interrupt and can be used to wake-up the device from any sleep mode.

Each interrupt source has an interrupt flag associated with it. The interrupt flag in the Interrupt Flag Status and Clear (INTFLAG) register is set when the interrupt condition occurs. Each interrupt can be individually enabled by writing a one to the corresponding bit in the Interrupt Enable Set (INTENSET) register, and disabled by writing a one to the corresponding bit in the Interrupt Enable Clear (INTENCLR) register. An interrupt request is generated when the interrupt flag is set and the corresponding interrupt is enabled. The interrupt request remains active until the interrupt flag is cleared, the interrupt is disabled, or the I<sup>2</sup>S is reset. Refer to the INTFLAG register for details on how to clear interrupt flags. All interrupt requests from the peripheral are ORed together on system level to generate one combined interrupt request to the NVIC. Refer to the “*Nested Vector Interrupt Controller*” for details. The user must read the INTFLAG register to determine which interrupt condition is present.

**Note:** Interrupts must be globally enabled for interrupt requests to be generated. Refer to *Nested Vector Interrupt Controller* for details.

#### Related Links

[10.2 Nested Vector Interrupt Controller](#)

### 51.6.8.3 Events

Not applicable.

### 51.6.9 Sleep Mode Operation

The I<sup>2</sup>S continues to operate in all sleep modes that still provide its clocks.

### 51.6.10 Synchronization

Due to asynchronicity between the main clock domain and the peripheral clock domains, some registers need to be synchronized when written or read.

When executing an operation that requires synchronization, the corresponding Synchronization Busy bit in the Synchronization Busy register (SYNCBUSY) will be set immediately, and cleared when synchronization is complete.

If an operation that requires synchronization is executed while the corresponding SYNCBUSY bit is '1', a peripheral bus error is generated.

The following bits are synchronized when written:

- Software Reset bit in the Control A register (CTRLA.SWRST). SYNCBUSY.SWRST is set to '1' while synchronization is in progress.
- Enable bit in the Control A register (CTRLA.ENABLE). SYNCBUSY.ENABLE is set to '1' while synchronization is in progress.

- Clock Unit x Enable bits in the Control A register (CTRLA.CKENx). SYNCBUSY.CKENx is set to '1' while synchronization is in progress.
- Serializer Enable bits in the Control A register (CTRLA.TXEN and CTRLA.RXEN). SYNCBUSY.TXEN/RXEN is set to '1' while synchronization is in progress.

The following registers require synchronization when read or written:

- Transmit Data register (TXDATA) is Write-Synchronized. SYNCBUSY.TXDATA is set to '1' while synchronization is in progress.
- Receive Data register (RXDATA) is Read-Synchronized. SYNCBUSY.RXDATA is set to '1' while synchronization is in progress.

Synchronization is denoted by the Read-Synchronized or Write-Synchronized property in the register description.

### 51.6.11 Loop-Back Mode

For debugging purposes, the I<sup>2</sup>S can be configured to loop back the Transmitter to the Receiver. Writing a '1' to the Loop-Back Test Mode bit in the Rx Serializer Control register (RXCTRL.RXLOOP) will connect SDO to SDI, so that transmitted data is also received.

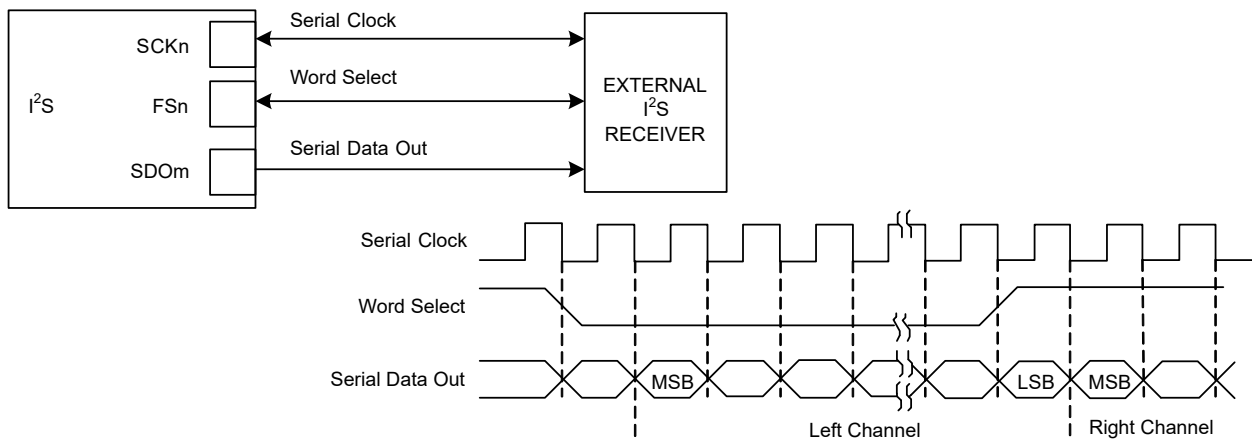
Writing RXCTRL.RXLOOP=0 will restore the normal behavior and connection between Receive Serializer and SDI pin input. As for other changes to the Serializers configuration, the Receive Serializer must be disabled before writing the TXCTRL register to update TXCTRL.RXLOOP.

## 51.7 I<sup>2</sup>S Application Examples

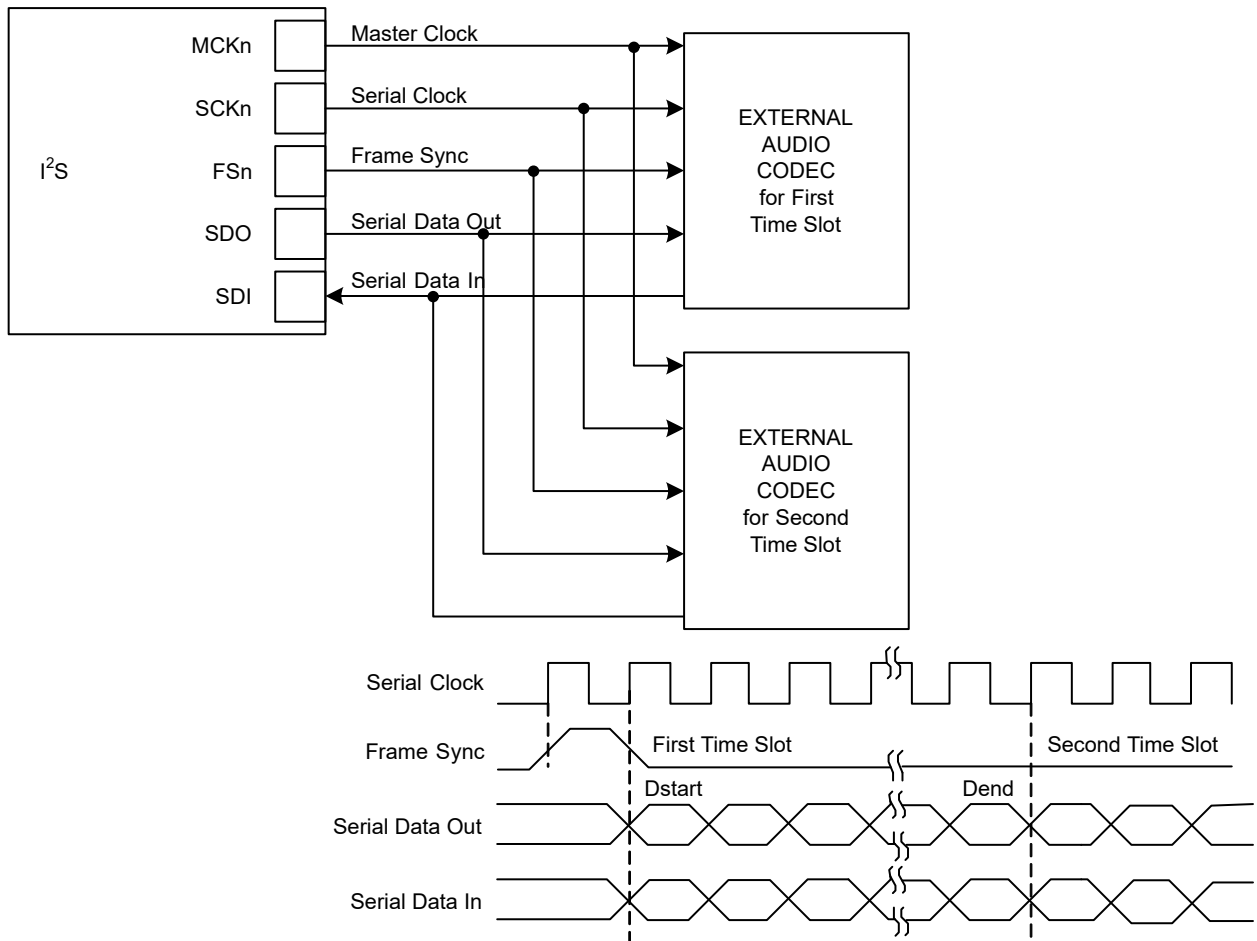
The I<sup>2</sup>S can support several serial communication modes used in audio or high-speed serial links. Some standard applications are shown in the following figures.

**Note:** The following examples are not a complete list of serial link applications supported by the I<sup>2</sup>S.

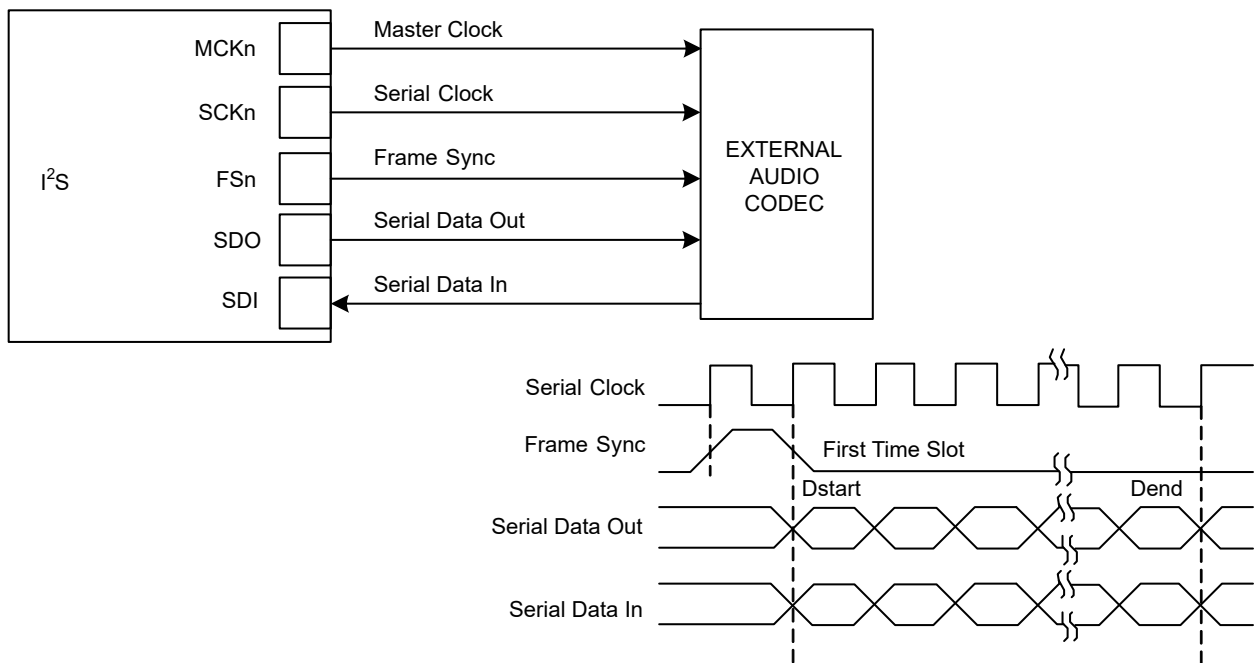
**Figure 51-7. Audio Application Block Diagram**



**Figure 51-8. Time Slot Application Block Diagram**



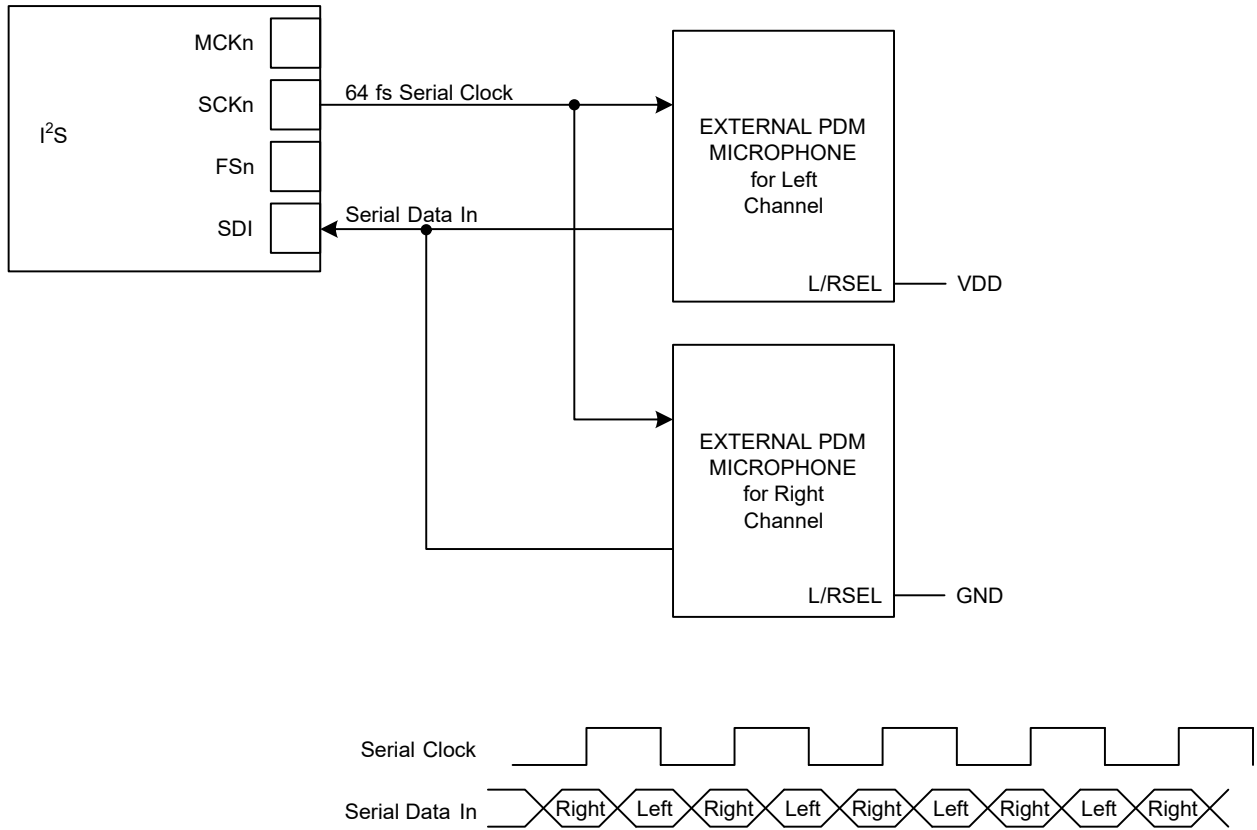
**Figure 51-9. Codec Application Block Diagram**



# SAM D5x/E5x Family Data Sheet

## I2S - Inter-IC Sound Controller

**Figure 51-10. PDM Microphones Application Block Diagram**





# SAM D5x/E5x Family Data Sheet

## I2S - Inter-IC Sound Controller

### 51.8 Register Summary

Offset	Name	Bit Pos.									
0x00	<b>CTRLA</b>	7:0				RXEN	TXEN	CKEN1	CKEN0	ENABLE	SWRST
0x01 ... 0x03	Reserved										
0x04	<b>CLKCTRL0</b>	7:0	BITDELAY	FSWIDTH[1:0]		NBSLOTS[2:0]			SLOTSIZE[1:0]		
		15:8	MCKOUTINV	MCKEN	MCKSEL	SCKOUTINV	SCKSEL	FSOUTINV	FSINV	FSSEL	
		23:16				MCKDIV[5:0]					
		31:24				MCKOUTDIV[5:0]					
0x08	<b>CLKCTRL1</b>	7:0	BITDELAY	FSWIDTH[1:0]		NBSLOTS[2:0]			SLOTSIZE[1:0]		
		15:8	MCKOUTINV	MCKEN	MCKSEL	SCKOUTINV	SCKSEL	FSOUTINV	FSINV	FSSEL	
		23:16				MCKDIV[5:0]					
		31:24				MCKOUTDIV[5:0]					
0x0C	<b>INTENCLR</b>	7:0				RXOR1	RXOR0			RXRDY1	RXRDY0
		15:8				TXUR1	TXUR0			TXRDY1	TXRDY0
0x0E ... 0x0F	Reserved										
0x10	<b>INTENSET</b>	7:0				RXOR1	RXOR0			RXRDY1	RXRDY0
		15:8				TXUR1	TXUR0			TXRDY1	TXRDY0
0x12 ... 0x13	Reserved										
0x14	<b>INTFLAG</b>	7:0				RXOR1	RXOR0			RXRDY1	RXRDY0
		15:8				TXUR1	TXUR0			TXRDY1	TXRDY0
0x16 ... 0x17	Reserved										
0x18	<b>SYNCBUSY</b>	7:0				RXEN	TXEN	CKEN1	CKEN0	ENABLE	SWRST
		15:8								RXDATA	TXDATA
0x1A ... 0x1F	Reserved										
0x20	<b>TXCTRL</b>	7:0	SLOTADJ			TXSAME	TXDEFAULT[1:0]				
		15:8	BITREV	EXTEND[1:0]		WORDADJ		DATASIZE[2:0]			
		23:16	SLOTDIS7	SLOTDIS6	SLOTDIS5	SLOTDIS4	SLOTDIS3	SLOTDIS2	SLOTDIS1	SLOTDIS0	
		31:24								DMA	MONO
0x24	<b>RXCTRL</b>	7:0	SLOTADJ		CLKSEL			SERMODE[1:0]			
		15:8	BITREV	EXTEND[1:0]		WORDADJ		DATASIZE[2:0]			
		23:16	SLOTDIS7	SLOTDIS6	SLOTDIS5	SLOTDIS4	SLOTDIS3	SLOTDIS2	SLOTDIS1	SLOTDIS0	
		31:24						RXLOOP	DMA	MONO	
0x28 ... 0x2F	Reserved										

# SAM D5x/E5x Family Data Sheet

## I2S - Inter-IC Sound Controller

.....continued

Offset	Name	Bit Pos.							
0x30	TXDATA	7:0	DATA[7:0]						
		15:8	DATA[15:8]						
		23:16	DATA[23:16]						
		31:24	DATA[31:24]						
0x34	RXDATA	7:0	DATA[7:0]						
		15:8	DATA[15:8]						
		23:16	DATA[23:16]						
		31:24	DATA[31:24]						

### 51.9 Register Description

Registers can be 8, 16, or 32 bits wide. Atomic 8-, 16-, and 32-bit accesses are supported. In addition, the 8-bit quarters and 16-bit halves of a 32-bit register, and the 8-bit halves of a 16-bit register can be accessed directly.

Some registers require synchronization when read and/or written. Synchronization is denoted by the "Read-Synchronized" and/or "Write-Synchronized" property in each individual register description.

Some registers are enable-protected, meaning they can only be written when the module is disabled. Enable protection is denoted by the "Enable-Protected" property in each individual register description.

Optional write protection by the Peripheral Access Controller (PAC) is denoted by the "PAC Write Protection" property in each individual register description.

# SAM D5x/E5x Family Data Sheet

## I2S - Inter-IC Sound Controller

### 51.9.1 Control A

**Name:** CTRLA  
**Offset:** 0x00  
**Reset:** 0x00  
**Property:** PAC Write-Protection

Bit	7	6	5	4	3	2	1	0
			RXEN	TXEN	CKEN1	CKEN0	ENABLE	SWRST
Access			R/W	R/W	R/W	R/W	R/W	R/W
Reset			0	0	0	0	0	0

#### Bit 5 – RXEN Rx Serializer Enable

Writing a '0' to this bit will disable the Rx Serializer.

Writing a '1' to this bit will enable the Rx Serializer.

Value	Description
0	The Rx Serializer is disabled.
1	The Rx Serializer is enabled.

#### Bit 4 – TXEN Tx Serializer Enable

Writing a '0' to this bit will disable the Tx Serializer.

Writing a '1' to this bit will enable the Tx Serializer.

Value	Description
0	The Tx Serializer is disabled.
1	The Tx Serializer is enabled.

#### Bits 2, 3 – CKENx Clock Unit x Enable [x=1..0]

Writing a '0' to this bit will disable the Clock Unit x.

Writing a '1' to this bit will enable the Clock Unit x.

Value	Description
0	The Clock Unit x is disabled.
1	The Clock Unit x is enabled.

#### Bit 1 – ENABLE Enable

Writing a '0' to this bit will disable the module.

Writing a '1' to this bit will enable the module.

Value	Description
0	The peripheral is disabled.
1	The peripheral is enabled.

#### Bit 0 – SWRST Software Reset

Writing a '0' to this bit has no effect.

Writing a '1' to this bit resets all registers to their initial state, and the peripheral will be disabled.

Writing a '1' to CTRL.SWRST will always take precedence, meaning that all other writes in the same write-operation will be discarded.

The I<sup>2</sup>S generic clocks must be enabled before triggering Software Reset, hence the logic in all clock domains can be reset.

Value	Description
0	There is no reset operation ongoing.

# SAM D5x/E5x Family Data Sheet

## I2S - Inter-IC Sound Controller

---

---

Value	Description
1	The reset operation is ongoing.

# SAM D5x/E5x Family Data Sheet

## I2S - Inter-IC Sound Controller

### 51.9.2 Clock Unit n Control

**Name:** CLKCTRL  
**Offset:** 0x04 + n\*0x04 [n=0..1]  
**Reset:** 0x00000000  
**Property:** Enable-Protected, PAC Write-Protection

	Bit	31	30	29	28	27	26	25	24
		MCKOUTDIV[5:0]							
Access				R/W	R/W	R/W	R/W	R/W	R/W
Reset				0	0	0	0	0	0
	Bit	23	22	21	20	19	18	17	16
		MCKDIV[5:0]							
Access				R/W	R/W	R/W	R/W	R/W	R/W
Reset				0	0	0	0	0	0
	Bit	15	14	13	12	11	10	9	8
		MCKOUTINV	MCKEN	MCKSEL	SCKOUTINV	SCKSEL	FSOUTINV	FSINV	FSSEL
Access		R/W	R/W	R/W	R/W	R/W	R/W	R/W	R/W
Reset		0	0	0	0	0	0	0	0
	Bit	7	6	5	4	3	2	1	0
		BITDELAY	FSWIDTH[1:0]		NBSLOTS[2:0]			SLOTSIZE[1:0]	
Access		R/W	R/W	R/W	R/W	R/W	R/W	R/W	R/W
Reset		0	0	0	0	0	0	0	0

**Bits 29:24 – MCKOUTDIV[5:0]** Master Clock Output Division Factor

The generic clock selected by MCKSEL is divided by (MCKOUTDIV + 1) to obtain the Master Clock n output.

**Bits 21:16 – MCKDIV[5:0]** Master Clock Division Factor

The Master Clock n is divided by (MCKDIV + 1) to obtain the Serial Clock n.

**Bit 15 – MCKOUTINV** Master Clock Output Invert

Value	Description
0	The Master Clock n is output without inversion.
1	The Master Clock n is inverted before being output.

**Bit 14 – MCKEN** Master Clock Enable

**Note:** MCKEN will not enable the clock output when in Slave mode.

Value	Description
0	The Master Clock n division and output is disabled.
1	The Master Clock n division and output is enabled.

**Bit 13 – MCKSEL** Master Clock Select

This field selects the source of the Master Clock n.

MCKSEL	Name	Description
0x0	GCLK	GCLK_I2S_n is used as Master Clock n source
0x1	MCKPIN	MCKn input pin is used as Master Clock n source

**Bit 12 – SCKOUTINV** Serial Clock Output Invert

Value	Description
0	The Serial Clock n is output without inversion.
1	The Serial Clock n is inverted before being output.

**Bit 11 – SCKSEL** Serial Clock Select

This field selects the source of the Serial Clock n.

SCKSEL	Name	Description
0x0	MCKDIV	Divided Master Clock n is used as Serial Clock n source
0x1	SCKPIN	SCKn input pin is used as Serial Clock n source

**Bit 10 – FSOUTINV** Frame Sync Output Invert

Value	Description
0	The Frame Sync n is output without inversion.
1	The Frame Sync n is inverted before being output.

**Bit 9 – FSINV** Frame Sync Invert

Value	Description
0	The Frame Sync n is used without inversion.
1	The Frame Sync n is inverted before being used.

**Bit 8 – FSSEL** Frame Sync Select

This field selects the source of the Frame Sync n.

FSSEL	Name	Description
0x0	SCKDIV	Divided Serial Clock n is used as Frame Sync n source
0x1	FSPIN	FSn input pin is used as Frame Sync n source

**Bit 7 – BITDELAY** Data Delay from Frame Sync

BITDELAY	Name	Description
0x0	LJ	Left Justified (0 Bit Delay)
0x1	I2S	I2S (1 Bit Delay)

**Bits 6:5 – FSWIDTH[1:0]** Frame Sync Width

This field selects the duration of the Frame Sync output pulses.

When not in Burst mode, the Clock unit n operates in continuous mode when enabled, with periodic Frame Sync pulses and Data samples.

In Burst mode, a single Data transfer starts at each Frame Sync pulse; these pulses are 1-bit wide and occur only when a Data transfer is requested. Note that the compact stereo modes (16C and 8C) are not supported in the Burst mode.

# SAM D5x/E5x Family Data Sheet

## I2S - Inter-IC Sound Controller

FSWIDTH[1:0]	Name	Description
0x0	SLOT	Frame Sync Pulse is 1 Slot wide (default for I2S protocol)
0x1	HALF	Frame Sync Pulse is half a Frame wide
0x2	BIT	Frame Sync Pulse is 1 Bit wide
0x3	BURST	Clock Unit n operates in Burst mode, with a 1-bit wide Frame Sync pulse per Data sample, only when Data transfer is requested

### Bits 4:2 – NBSLOTS[2:0] Number of Slots in Frame

Each Frame for Clock Unit n is composed of (NBSLOTS + 1) Slots.

### Bits 1:0 – SLOTSIZE[1:0] Slot Size

Each Slot for Clock Unit n is composed of a number of bits specified by SLOTSIZE.

SLOTSIZE[1:0]	Name	Description
0x0	8	8-bit Slot for Clock Unit n
0x1	16	16-bit Slot for Clock Unit n
0x2	24	24-bit Slot for Clock Unit n
0x3	32	32-bit Slot for Clock Unit n

### 51.9.3 Interrupt Enable Clear

**Name:** INTENCLR  
**Offset:** 0x0C  
**Reset:** 0x0000  
**Property:** PAC Write-Protection

	Bit	15	14	13	12	11	10	9	8
				TXUR1	TXUR0			TXRDY1	TXRDY0
Access				R/W	R/W			R/W	R/W
Reset				0	0			0	0
	Bit	7	6	5	4	3	2	1	0
				RXOR1	RXOR0			RXRDY1	RXRDY0
Access				R/W	R/W			R/W	R/W
Reset				0	0			0	0

#### Bits 12, 13 – TXURx Transmit Underrun x Interrupt Enable [x=1..0]

Writing a '0' to this bit has no effect.

Writing a '1' to this bit will clear the Transmit Underrun x Interrupt Enable bit, which disables the Transmit Underrun x interrupt.

Value	Description
0	The Transmit Underrun x interrupt is disabled.
1	The Transmit Underrun x interrupt is enabled.

#### Bits 8, 9 – TXRDYx Transmit Ready x Interrupt Enable [x=1..0]

Writing a '0' to this bit has no effect.

Writing a '1' to this bit will clear the Transmit Ready x Interrupt Enable bit, which disables the Transmit Ready x interrupt.

Value	Description
0	The Transmit Ready x interrupt is disabled.
1	The Transmit Ready x interrupt is enabled.

#### Bits 4, 5 – RXORx Receive Overrun x Interrupt Enable [x=1..0]

Writing a '0' to this bit has no effect.

Writing a '1' to this bit will clear the Receive Overrun x Interrupt Enable bit, which disables the Receive Overrun x interrupt.

Value	Description
0	The Receive Overrun x interrupt is disabled.
1	The Receive Overrun x interrupt is enabled.

#### Bits 0, 1 – RXRDYx Receive Ready x Interrupt Enable [x=1..0]

Writing a '0' to this bit has no effect.

Writing a '1' to this bit will clear the Receive Ready x Interrupt Enable bit, which disables the Receive Ready x interrupt.

Value	Description
0	The Receive Ready x interrupt is disabled.
1	The Receive Ready x interrupt is enabled.



### 51.9.4 Interrupt Enable Set

**Name:** INTENSET  
**Offset:** 0x10  
**Reset:** 0x0000  
**Property:** PAC Write-Protection

	Bit	15	14	13	12	11	10	9	8
				TXUR1	TXUR0			TXRDY1	TXRDY0
Access				R/W	R/W			R/W	R/W
Reset				0	0			0	0
	Bit	7	6	5	4	3	2	1	0
				RXOR1	RXOR0			RXRDY1	RXRDY0
Access				R/W	R/W			R/W	R/W
Reset				0	0			0	0

**Bits 12, 13 – TXURx** Transmit Underrun x Interrupt Enable [x=1..0]

Writing a '0' to this bit has no effect.

Writing a '1' to this bit will set the Transmit Underrun Interrupt Enable bit, which enables the Transmit Underrun interrupt.

Value	Description
0	The Transmit Underrun interrupt is disabled.
1	The Transmit Underrun interrupt is enabled.

**Bits 8, 9 – TXRDYx** Transmit Ready x Interrupt Enable [x=1..0]

Writing a '0' to this bit has no effect.

Writing a '1' to this bit will set the Transmit Ready Interrupt Enable bit, which enables the Transmit Ready interrupt.

Value	Description
0	The Transmit Ready interrupt is disabled.
1	The Transmit Ready interrupt is enabled.

**Bits 4, 5 – RXORx** Receive Overrun x Interrupt Enable [x=1..0]

Writing a '0' to this bit has no effect.

Writing a '1' to this bit will set the Receive Overrun Interrupt Enable bit, which enables the Receive Overrun interrupt.

Value	Description
0	The Receive Overrun interrupt is disabled.
1	The Receive Overrun interrupt is enabled.

**Bits 0, 1 – RXRDYx** Receive Ready x Interrupt Enable [x=1..0]

Writing a '0' to this bit has no effect.

Writing a '1' to this bit will set the Receive Ready Interrupt Enable bit, which enables the Receive Ready interrupt.

Value	Description
0	The Receive Ready interrupt is disabled.
1	The Receive Ready interrupt is enabled.

### 51.9.5 Interrupt Flag Status and Clear

**Name:** INTFLAG  
**Offset:** 0x14  
**Reset:** 0x0000  
**Property:** -

	Bit	15	14	13	12	11	10	9	8
				TXUR1	TXUR0			TXRDY1	TXRDY0
Access				R/W	R/W			R/W	R/W
Reset				0	0			0	0
	Bit	7	6	5	4	3	2	1	0
				RXOR1	RXOR0			RXRDY1	RXRDY0
Access				R/W	R/W			R/W	R/W
Reset				0	0			0	0

**Bits 12, 13 – TXURx** Transmit Underrun x [x=1..0]

This flag is cleared by writing a '1' to it.

This flag is set when a Transmit Underrun condition occurs in Sequencer x, and will generate an interrupt request if INTENCLR/SET.TXURx is set to '1'.

Writing a '0' to this bit has no effect.

Writing a '1' to this bit will clear the Transmit Underrun x interrupt flag.

**Bits 8, 9 – TXRDYx** Transmit Ready x [x=1..0]

This flag is cleared by writing to DATAx register or writing a '1' to it.

This flag is set when Sequencer x is ready to accept a new data word to be transmitted, and will generate an interrupt request if INTENCLR/SET.TXRDYx is set to '1'.

Writing a '0' to this bit has no effect.

Writing a '1' to this bit will clear the Transmit Ready x interrupt flag.

**Bits 4, 5 – RXORx** Receive Overrun x [x=1..0]

This flag is cleared by writing a '1' to it.

This flag is set when a Receive Overrun condition occurs in Sequencer x, and will generate an interrupt request if INTENCLR/SET.RXORx is set to '1'.

Writing a '0' to this bit has no effect.

Writing a '1' to this bit will clear the Receive Overrun x interrupt flag.

**Bits 0, 1 – RXRDYx** Receive Ready x [x=1..0]

This flag is cleared by reading from DATAx register or writing a '1' to it.

This flag is set when a Sequencer x has received a new data word, and will generate an interrupt request if INTENCLR/SET.RXRDYx is set to '1'.

Writing a '0' to this bit has no effect.

Writing a '1' to this bit will clear the Receive Ready x interrupt flag.

# SAM D5x/E5x Family Data Sheet

## I2S - Inter-IC Sound Controller

### 51.9.6 Synchronization Busy

**Name:** SYNCBUSY  
**Offset:** 0x18  
**Reset:** 0x0000  
**Property:** -

	Bit	15	14	13	12	11	10	9	8
								RXDATA	TXDATA
Access								R	R
Reset								0	0
	Bit	7	6	5	4	3	2	1	0
				RXEN	TXEN	CKEN1	CKEN0	ENABLE	SWRST
Access				R	R	R	R	R	R
Reset				0	0	0	0	0	0

**Bit 9 – RXDATA** Rx Data Synchronization Status

This bit is cleared when the synchronization of the Rx DATA Holding (RXDATA) register between the clock domains is complete.

This bit is set when the synchronization of the Rx DATA Holding (RXDATA) register between the clock domains is started.

**Bit 8 – TXDATA** Tx Data Synchronization Status

This bit is cleared when the synchronization of the Tx DATA Holding (TXDATA) register between the clock domains is complete.

This bit is set when the synchronization of the Tx DATA Holding (TXDATA) register between the clock domains is started.

**Bit 5 – RXEN** Rx Serializer Enable Synchronization Status

This bit is cleared when the synchronization of the CTRLA.RXEN bit between the clock domains is complete.

This bit is set when the synchronization of the CTRLA.RXEN bit between the clock domains is started.

**Bit 4 – TXEN** Tx Serializer Enable Synchronization Status

This bit is cleared when the synchronization of the CTRLA.TXEN bit between the clock domains is complete.

This bit is set when the synchronization of the CTRLA.TXEN bit between the clock domains is started.

**Bits 2, 3 – CKENx** Clock Unit x Enable Synchronization Status [x=1..0]

Bit CKENx is cleared when the synchronization of the CTRLA.CKENx bit between the clock domains is complete.

Bit CKENx is set when the synchronization of the CTRLA.CKENx bit between the clock domains is started.

**Bit 1 – ENABLE** Enable Synchronization Status

This bit is cleared when the synchronization of the CTRLA.ENABLE bit between the clock domains is complete.

This bit is set when the synchronization of the CTRLA.ENABLE bit between the clock domains is started.

**Bit 0 – SWRST** Software Reset Synchronization Status

This bit is cleared when the synchronization of the CTRLA.SWRST bit between the clock domains is complete.

This bit is set when the synchronization of the CTRLA.SWRST bit between the clock domains is started.

# SAM D5x/E5x Family Data Sheet

## I2S - Inter-IC Sound Controller

### 51.9.7 Tx Serializer Control

**Name:** TXCTRL  
**Offset:** 0x20  
**Reset:** 0x00000000  
**Property:** Enable-Protected, Write-Protection

	Bit	31	30	29	28	27	26	25	24
								DMA	MONO
Access								R/W	R/W
Reset								0	0
	Bit	23	22	21	20	19	18	17	16
		SLOTDIS7	SLOTDIS6	SLOTDIS5	SLOTDIS4	SLOTDIS3	SLOTDIS2	SLOTDIS1	SLOTDIS0
Access		R/W	R/W	R/W	R/W	R/W	R/W	R/W	R/W
Reset		0	0	0	0	0	0	0	0
	Bit	15	14	13	12	11	10	9	8
		BITREV	EXTEND[1:0]		WORDADJ		DATASIZE[2:0]		
Access		R/W	R/W	R/W	R/W		R/W	R/W	R/W
Reset		0	0	0	0		0	0	0
	Bit	7	6	5	4	3	2	1	0
		SLOTADJ			TXSAME	TXDEFAULT[1:0]			
Access		R/W			R/W	R/W	R/W		
Reset		0			0	0	0		

#### Bit 25 – DMA Single or Multiple DMA Channels

This bit selects whether even-numbered and odd-numbered slots use separate DMA channels or the same DMA channel.

DMA	Name	Description
0x0	SINGLE	Single DMA channel
0x1	MULTIPLE	One DMA channel per data channel

#### Bit 24 – MONO Mono Mode.

MONO	Name	Description
0x0	STEREO	Normal mode
0x1	MONO	Left channel data is duplicated to right channel

#### Bits 16, 17, 18, 19, 20, 21, 22, 23 – SLOTDISx Slot x Disabled for this Serializer [x=7..0]

This field allows disabling some slots in each transmit frame:

Value	Description
0	Slot x is used for data transfer.
1	Slot x is not used for data transfer and will be output as specified in the TXDEFAULT field.

# SAM D5x/E5x Family Data Sheet

## I2S - Inter-IC Sound Controller

### Bit 15 – BITREV Data Formatting Bit Reverse

This bit allows changing the order of data bits in the word in the Formatting Unit.

BITREV	Name	Description
0x0	MSBIT	Transfer Data Most Significant Bit (MSB) first (default for I2S protocol)
0x1	LSBIT	Transfer Data Least Significant Bit (LSB) first

### Bits 14:13 – EXTEND[1:0] Data Formatting Bit Extension

This field defines the bit value used to extend data samples in the Formatting Unit.

EXTEND[1:0]	Name	Description
0x0	ZERO	Extend with zeros
0x1	ONE	Extend with ones
0x2	MSBIT	Extend with Most Significant Bit
0x3	LSBIT	Extend with Least Significant Bit

### Bit 12 – WORDADJ Data Word Formatting Adjust

This field defines left or right adjustment of data samples in the word in the Formatting Unit. for details.

WORDADJ	Name	Description
0x0	RIGHT	Data is right adjusted in word
0x1	LEFT	Data is left adjusted in word

### Bits 10:8 – DATASIZE[2:0] Data Word Size

This field defines the number of bits in each data sample. For 8-bit compact stereo, two 8-bit data samples are packed in bits 15 to 0 of the DATAm register. For 16-bit compact stereo, two 16-bit data samples are packed in bits 31 to 0 of the DATAm register.

DATASIZE[2:0]	Name	Description
0x0	32	32 bits
0x1	24	24 bits
0x2	20	20 bits
0x3	18	18 bits
0x4	16	16 bits
0x5	16C	16 bits compact stereo
0x6	8	8 bits
0x7	8C	8 bits compact stereo

### Bit 7 – SLOTADJ Data Slot Formatting Adjust

This field defines left or right adjustment of data samples in the slot.

# SAM D5x/E5x Family Data Sheet

## I2S - Inter-IC Sound Controller

SLOTADJ	Name	Description
0x0	RIGHT	Data is right adjusted in slot
0x1	LEFT	Data is left adjusted in slot

**Bit 4 – TXSAME** Transmit Data when Underrun.

TXSAME	Name	Description
0x0	ZERO	Zero data transmitted in case of underrun
0x1	SAME	Last data transmitted in case of underrun

**Bits 3:2 – TXDEFAULT[1:0]** Line Default Line when Slot Disabled

This field defines the default value driven on the SDn output pin during all disabled Slots.

TXDEFAULT[1:0]	Name	Description
0x0	ZERO	Output Default Value is 0
0x1	ONE	Output Default Value is 1
0x2		Reserved
0x3	HIZ	Output Default Value is high impedance

# SAM D5x/E5x Family Data Sheet

## I2S - Inter-IC Sound Controller

### 51.9.8 Rx Serializer Control

**Name:** RXCTRL  
**Offset:** 0x24  
**Reset:** 0x00000000  
**Property:** Enable-Protected, PAC Write-Protection

	Bit	31	30	29	28	27	26	25	24
							RXLOOP	DMA	MONO
Access							R/W	R/W	R/W
Reset							0	0	0
	Bit	23	22	21	20	19	18	17	16
		SLOTDIS7	SLOTDIS6	SLOTDIS5	SLOTDIS4	SLOTDIS3	SLOTDIS2	SLOTDIS1	SLOTDIS0
Access		R/W	R/W	R/W	R/W	R/W	R/W	R/W	R/W
Reset		0	0	0	0	0	0	0	0
	Bit	15	14	13	12	11	10	9	8
		BITREV	EXTEND[1:0]		WORDADJ		DATASIZE[2:0]		
Access		R/W	R/W	R/W	R/W		R/W	R/W	R/W
Reset		0	0	0	0		0	0	0
	Bit	7	6	5	4	3	2	1	0
		SLOTADJ		CLKSEL				SERMODE[1:0]	
Access		R/W		R/W				R/W	R/W
Reset		0		0				0	0

#### Bit 26 – RXLOOP Loop-back Test Mode

This bit enables a loop-back test mode:

Value	Description
0	Each Receiver uses its SDn pin as input (default mode).
1	Receiver uses as input the transmitter output of the other Serializer in the pair: e.g. SD1 for SD0 or SD0 for SD1.

#### Bit 25 – DMA Single or Multiple DMA Channels

This bit selects whether even- and odd-numbered slots use separate DMA channels or the same DMA channel.

DMA	Name	Description
0x0	SINGLE	Single DMA channel
0x1	MULTIPLE	One DMA channel per data channel

#### Bit 24 – MONO Mono Mode.

MONO	Name	Description
0x0	STEREO	Normal mode
0x1	MONO	Left channel data is duplicated to right channel



# SAM D5x/E5x Family Data Sheet

## I2S - Inter-IC Sound Controller

**Bits 16, 17, 18, 19, 20, 21, 22, 23 – SLOTDISx** Slot x Disabled for this Serializer [x=7..0]

This field allows disabling some slots in each transmit frame:

Value	Description
0	Slot x is used for data transfer.
1	Slot x is not used for data transfer and will be output as specified in the TXDEFAULT field.

**Bit 15 – BITREV** Data Formatting Bit Reverse

This bit allows changing the order of data bits in the word in the Formatting Unit.

BITREV	Name	Description
0x0	MSBIT	Transfer Data Most Significant Bit (MSB) first (default for I2S protocol)
0x1	LSBIT	Transfer Data Least Significant Bit (LSB) first

**Bits 14:13 – EXTEND[1:0]** Data Formatting Bit Extension

This field defines the bit value used to extend data samples in the Formatting Unit.

EXTEND[1:0]	Name	Description
0x0	ZERO	Extend with zeros
0x1	ONE	Extend with ones
0x2	MSBIT	Extend with Most Significant Bit
0x3	LSBIT	Extend with Least Significant Bit

**Bit 12 – WORDADJ** Data Word Formatting Adjust

This field defines left or right adjustment of data samples in the word in the Formatting Unit. for details.

WORDADJ	Name	Description
0x0	RIGHT	Data is right adjusted in word
0x1	LEFT	Data is left adjusted in word

**Bits 10:8 – DATASIZE[2:0]** Data Word Size

This field defines the number of bits in each data sample. For 8-bit compact stereo, two 8-bit data samples are packed in bits 15 to 0 of the DATAm register. For 16-bit compact stereo, two 16-bit data samples are packed in bits 31 to 0 of the DATAm register.

DATASIZE[2:0]	Name	Description
0x0	32	32 bits
0x1	24	24 bits
0x2	20	20 bits
0x3	18	18 bits
0x4	16	16 bits
0x5	16C	16 bits compact stereo
0x6	8	8 bits

# SAM D5x/E5x Family Data Sheet

## I2S - Inter-IC Sound Controller

.....continued

DATASIZE[2:0]	Name	Description
0x7	8C	8 bits compact stereo

### Bit 7 – SLOTADJ Data Slot Formatting Adjust

This field defines left or right adjustment of data samples in the slot.

SLOTADJ	Name	Description
0x0	RIGHT	Data is right adjusted in slot
0x1	LEFT	Data is left adjusted in slot

### Bit 5 – CLKSEL Clock Unit Selection.

CLKSEL	Name	Description
0x0	CLK0	Use Clock Unit 0
0x1	CLK1	Use Clock Unit 1

### Bits 1:0 – SERMODE[1:0] Serializer Mode.

SERMODE[1:0]	Name	Description
0x0	RX	Receive
0x1		Reserved
0x2	PDM2	Receive one PDM data on each serial clock edge
0x3		Reserved

# SAM D5x/E5x Family Data Sheet

## I2S - Inter-IC Sound Controller

### 51.9.9 Tx Data

**Name:** TXDATA  
**Offset:** 0x30  
**Reset:** 0x00000000  
**Property:** Write-Synchronized

Bit	31	30	29	28	27	26	25	24
	DATA[31:24]							
Access	R/W	R/W	R/W	R/W	R/W	R/W	R/W	R/W
Reset	0	0	0	0	0	0	0	0
Bit	23	22	21	20	19	18	17	16
	DATA[23:16]							
Access	R/W	R/W	R/W	R/W	R/W	R/W	R/W	R/W
Reset	0	0	0	0	0	0	0	0
Bit	15	14	13	12	11	10	9	8
	DATA[15:8]							
Access	R/W	R/W	R/W	R/W	R/W	R/W	R/W	R/W
Reset	0	0	0	0	0	0	0	0
Bit	7	6	5	4	3	2	1	0
	DATA[7:0]							
Access	R/W	R/W	R/W	R/W	R/W	R/W	R/W	R/W
Reset	0	0	0	0	0	0	0	0

#### Bits 31:0 – DATA[31:0] Sample Data

This register is used to transfer data to the Tx Serializer.

Data samples written to TXDATA register will be sent to Tx Serializer for transmission, through the Transmit Formatting Unit that will apply the formatting specified in the TXCTRL register.

# SAM D5x/E5x Family Data Sheet

## I2S - Inter-IC Sound Controller

### 51.9.10 Rx Data

**Name:** RXDATA  
**Offset:** 0x34  
**Reset:** 0x00000000  
**Property:** Read-Synchronized

	Bit	31	30	29	28	27	26	25	24
		DATA[31:24]							
Access		R/W	R/W	R/W	R/W	R/W	R/W	R/W	R/W
Reset		0	0	0	0	0	0	0	0
	Bit	23	22	21	20	19	18	17	16
		DATA[23:16]							
Access		R/W	R/W	R/W	R/W	R/W	R/W	R/W	R/W
Reset		0	0	0	0	0	0	0	0
	Bit	15	14	13	12	11	10	9	8
		DATA[15:8]							
Access		R/W	R/W	R/W	R/W	R/W	R/W	R/W	R/W
Reset		0	0	0	0	0	0	0	0
	Bit	7	6	5	4	3	2	1	0
		DATA[7:0]							
Access		R/W	R/W	R/W	R/W	R/W	R/W	R/W	R/W
Reset		0	0	0	0	0	0	0	0

#### Bits 31:0 – DATA[31:0] Sample Data

This register is used to transfer data from the Rx Serializer.

Data samples received by Rx Serializer will be available for reading from RXDATA register, through the Receive Formatting Unit, according to formatting information for Rx Serializer in the RXCTRL register.

## 52. PCC - Parallel Capture Controller

### 52.1 Overview

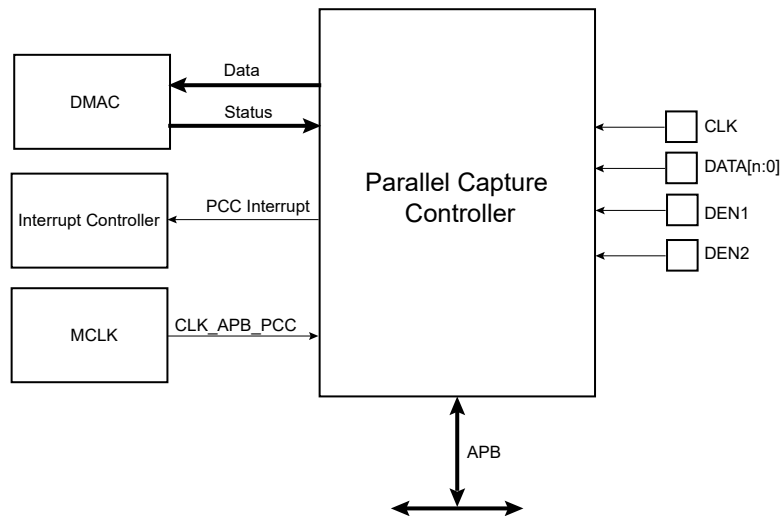
The Parallel Capture Controller can be used to interface an external system, such as a CMOS digital image sensor, ADC, or DSP, and capture its parallel data.

### 52.2 Features

- One clock, up to 14-bit parallel data and two Data Enable on I/O lines
- Data can be sampled every other time (e.g. for chrominance sampling)
- Supports connection of the DMAC which offers buffer reception without processor intervention
- Auto-scale feature available when 10, 12 or 14 bits data size is selected.
- Can be used to interface a CMOS Digital Image Sensor, an ADC, etc.

### 52.3 Block Diagram

Figure 52-1. Block Diagram



### 52.4 Signal Description

Signal	Description	Type
CLK	Digital input	PCC Clock
DATA[n:0]	Digital input	Data [n:0]
DEN1	Digital input	Data Enable 1
DEN2	Digital input	Data Enable 2

### 52.5 Product Dependencies

For the Parallel Capture Controller to function as intended, other interconnected modules of the system must be configured accordingly.

#### 52.5.1 I/O Lines

The PCC pins may be multiplexed with the I/O lines Controller. The user must first configure the I/O Controller to assign the PCC pins to their peripheral functions.

#### 52.5.2 Power Management

The PCC will continue to operate in any Sleep mode where the selected source clock is running. Events connected to the event system can trigger other operations in the system without exiting Sleep modes.

#### 52.5.3 Clocks

The PCC bus clock (CLK\_APB\_PCC) is provided by the Main Clock Controller (MCLK) through the AHB-APB D bridge. The clock is enabled and disabled by writing the PCC bit the in the APB D Mask register (MCLK.APBDMASK.PCC). See the register description for the default state of the PCC bus clock.

For capturing operation, the external device has to provide a PCC clock signal (PCC\_CLK) synchronous to the data received ("pixel clock") through a pin. See the PORT section and the Multiplexing table for details.

Writing any of the registers does not require the PCC\_CLK to be enabled.



**Important:** The CLK\_APB\_PCC clock frequency must be at least twice the PCC\_CLK frequency.

---

#### Related Links

- [15.7 Register Summary](#)
- [6. I/O Multiplexing and Considerations](#)
- [32. PORT - I/O Pin Controller](#)

#### 52.5.4 DMA

The DMAC can be configured to use the RX channel of the PCC as trigger source.

If configured, a trigger signal is send to the DMAC when data is received by the PCC, such that the DMAC will automatically read the received data buffer. The buffer ready signal will be automatically clear upon the read done by the DMAC.

#### Related Links

- [52.6.3 Programming Sequence](#)
- [52.6.3.1 Without DMAC](#)
- [52.6.3.2 With DMAC](#)

#### 52.5.5 Interrupts

The PCC has these interrupts:

- OVRE - Overrun Error interrupt
- DRDY - Data Ready interrupt

The interrupt request line is connected to the interrupt controller. Using the interrupts requires the interrupt controller to be configured first. Refer to NVIC - Nested Interrupt Nested Vector Interrupt Controller for details.

### 52.5.6 Events

Not applicable.

### 52.5.7 Debug Operation

When the CPU is halted in debug mode, the PCC will not halt normal operation.

**Note:** A buffer overflow condition will occur if the received data buffer is not read by CPU or CPU DMAC.

### 52.5.8 Register Access Protection

To prevent any single software error from corrupting PCC behavior, certain registers in the address space can be write-protected by setting the WPEN bit in the Write Protection Mode Register (WPMR).

If a write access to a write-protected register is detected, the WPVS flag in the Write Protection Status Register (WPSR) is set and WPSR.WPVSRC indicates the register in which the write access has been attempted.

The WPVS bit is automatically cleared after reading WPSR.

The following registers can be write-protected:

- PCC Mode Register

### 52.5.9 Analog Connections

Not applicable.

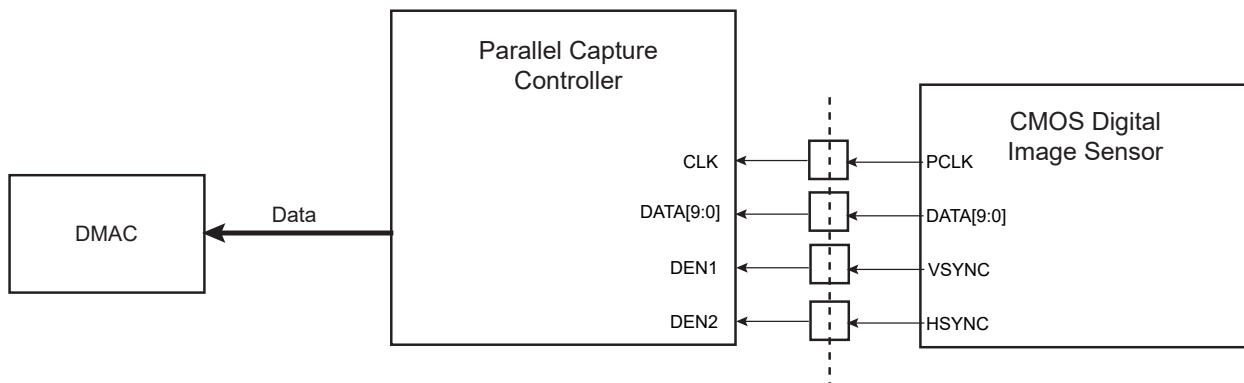
## 52.6 Functional Description

### 52.6.1 Principle of Operation

For better understanding and to ease reading, the following description uses an example with a CMOS digital image sensor.

The CMOS digital image sensor provides a sensor clock, an 10-bit data synchronous with the sensor clock and two data enables which are also synchronous with the sensor clock.

**Figure 52-2. Parallel Capture Controller Connection with CMOS Digital Image Sensor**



The PCC must be configured first, and is enabled by writing a '1' to the Parallel Capture Enable bit in the Mode Register (MR.PCEN).

# SAM D5x/E5x Family Data Sheet

## PCC - Parallel Capture Controller

---

Once enabled, the PCC samples the data at rising edge of the sensor clock, and resynchronizes it with the PCC clock domain.

The input data bus size can be programmed using the Input Data Size bit field (MR.ISIZE).

A re-initialization of the internal mechanism of the PCC can be automatically done by setting the CID register when a falling edge of the DEN1 or DEN2 is detected. This feature allows glitch filtering and prevents image de-synchronization.

The number of the data which can be read in the Reception Holding Register (RHR) can be programmed by writing the Data Size bit field (MR.DSIZE). The PCC samples one or several sensor data, according to the DSIZE value.

If the MR.SCALE bit is written to '1' and MR.ISIZE  $\neq$  0, the sampled data is automatically up-scaled to 16 bits. When the right number of data has been sampled, data are stored in the RHR, and the Data Ready flag in the Interrupt Status Register (ISR.DRDY) is set to '1'.

The PCC can be associated with a reception channel of the DMA Controller (DMAC). This performs reception transfer from the PCC to a memory buffer without any intervention from the CPU. Transfer status signals from the DMAC are available in the Interrupt Status Register through the flags ISR.ENDRX and ISR.RXBUFF.

The PCC can be configured to either comply with the sensor data enable signals, or not. If the Always Sampling bit in the Mode Register (MR.ALWYS) is written to '0', the PCC samples the sensor data at the rising edge of the sensor clock only if both data enable signals are active (at '1'). If ALWYS is written to '1', the PCC samples the sensor data at the rising edge of the sensor clock, independent of the data enable signals.

The PCC can be configured to sample the sensor data only every other time. This is particularly useful when only the luminance Y from a YUV422 data stream of a CMOS digital image sensor is to be sampled. If the Half Sampling bit in the Mode Register (MR.HALFS) is written to '0', the PCC samples the sensor data as configured above. If MR.HALFS=1, the PCC samples the sensor data as configured above (i.e. respecting the MR.ALWYS setting), but only one time out of two.

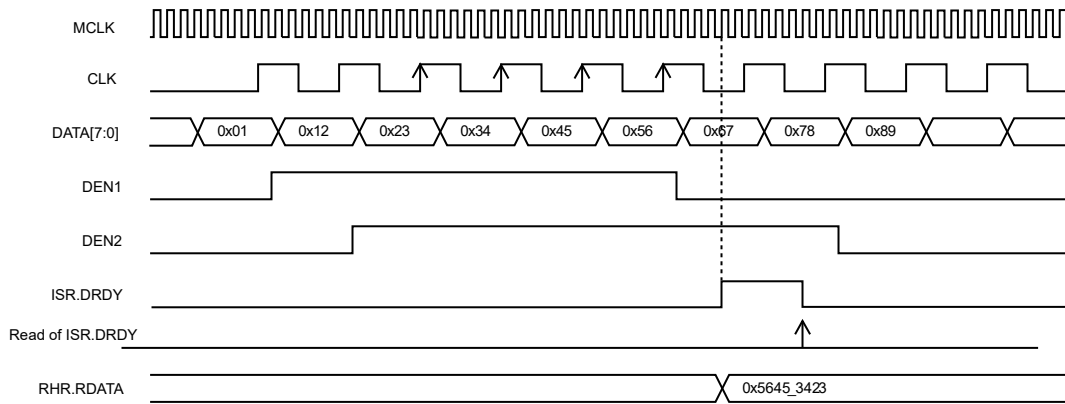
The PCC can either sample the even or odd sensor data, depending on the First Sample bit (MR.FRSTS). If sensor data are numbered with an index from zero to n in the order they are received and FRSTS=0, only data with an even index are sampled. For FRSTS=1, only data with an odd index are sampled.

If data are ready in the Reception Holding Register (RHR) but it is not read before new data is stored in RHR, an overrun error occurs: The previous data is lost and the Overrun Error flag in the Interrupt Status Register (ISR.OVRE) is set. This flag is automatically cleared when ISR is read (reset after read).

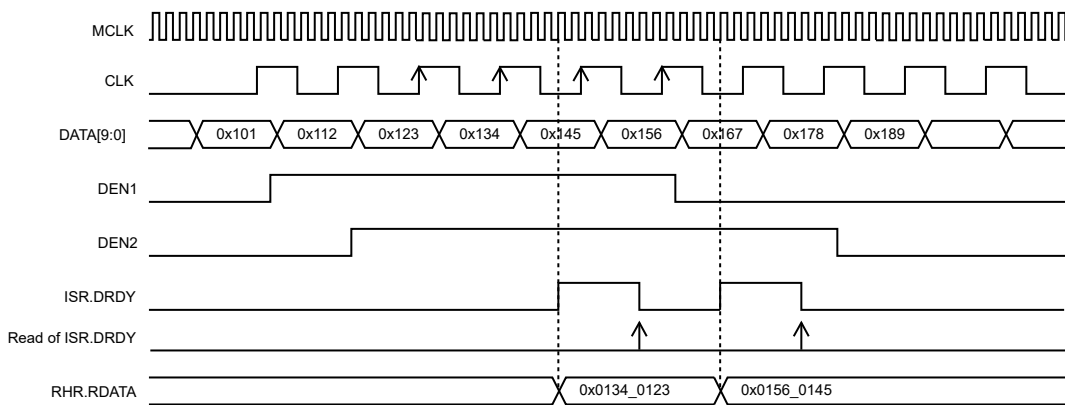
The flags ENDRX, RXBUFF, DRDY and OVRE can be a source of the PCC interrupt.



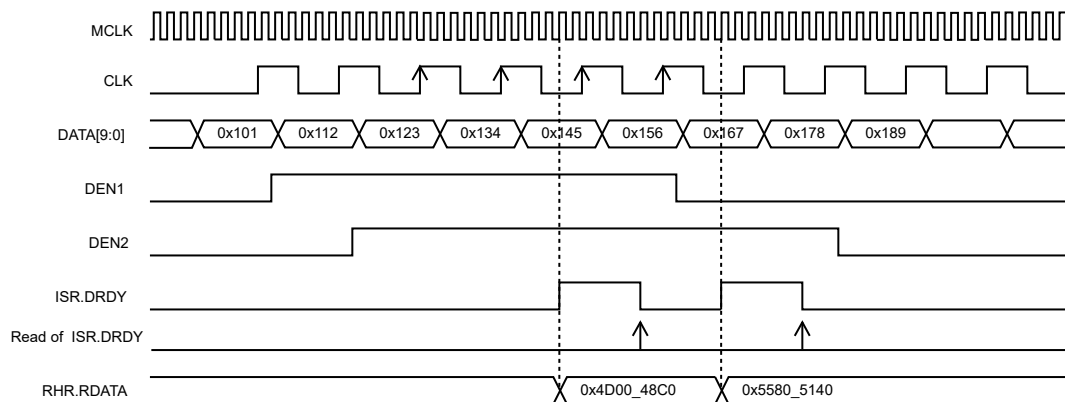
**Figure 52-3. PCC Waveforms (DSIZE=4\_DATA, ALWAYS = 0, HALFS = 0)**



**Figure 52-4. PCC Waveforms (ISIZE=10\_BITS, DSIZE=2\_DATA, ALWAYS = 0, HALFS = 0, SCALE = 0)**



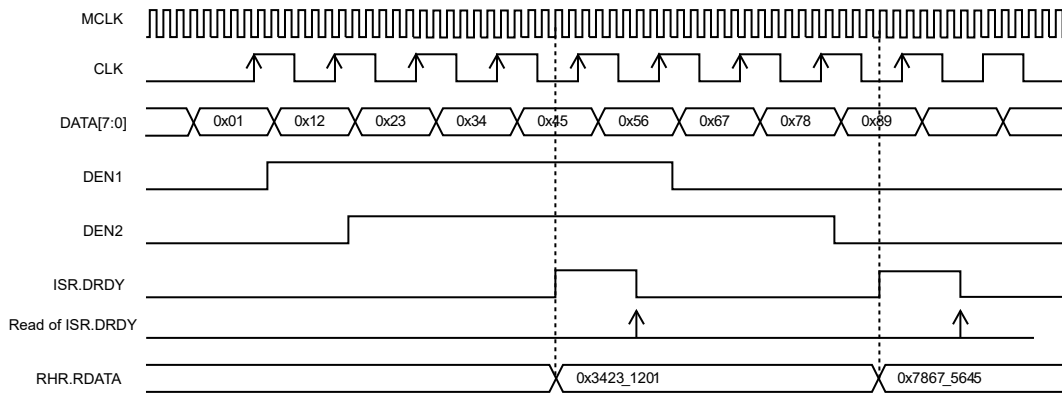
**Figure 52-5. PCC Waveforms (ISIZE=10\_BITS, DSIZE=2\_DATA, ALWAYS = 0, HALFS = 0, SCALE = 1)**



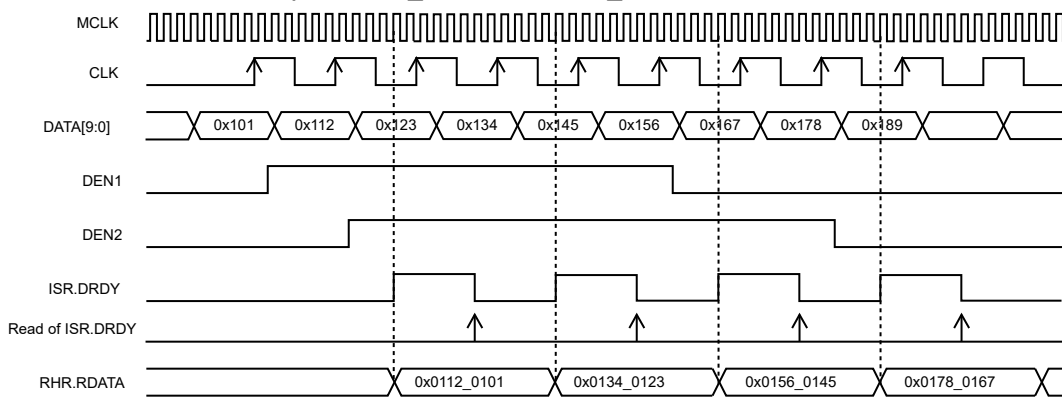
# SAM D5x/E5x Family Data Sheet

## PCC - Parallel Capture Controller

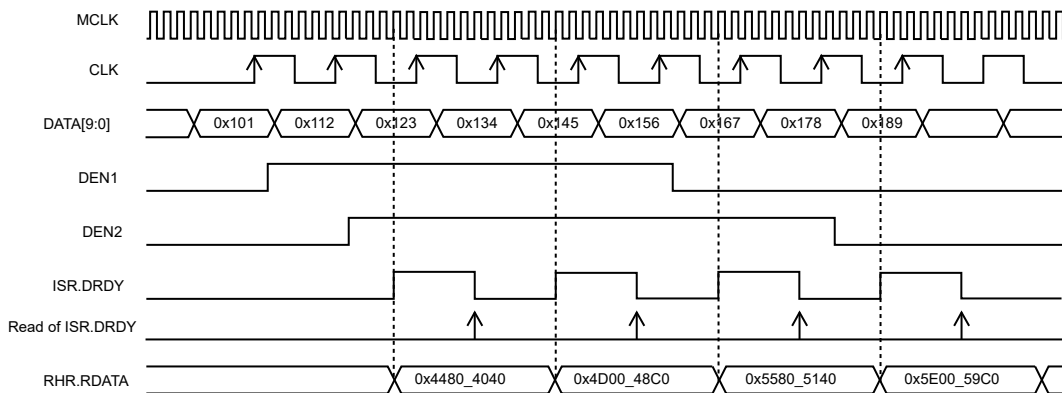
**Figure 52-6. PCC Waveforms (DSIZE=4\_DATA, ALWAYS = 1, HALFS = 0)**



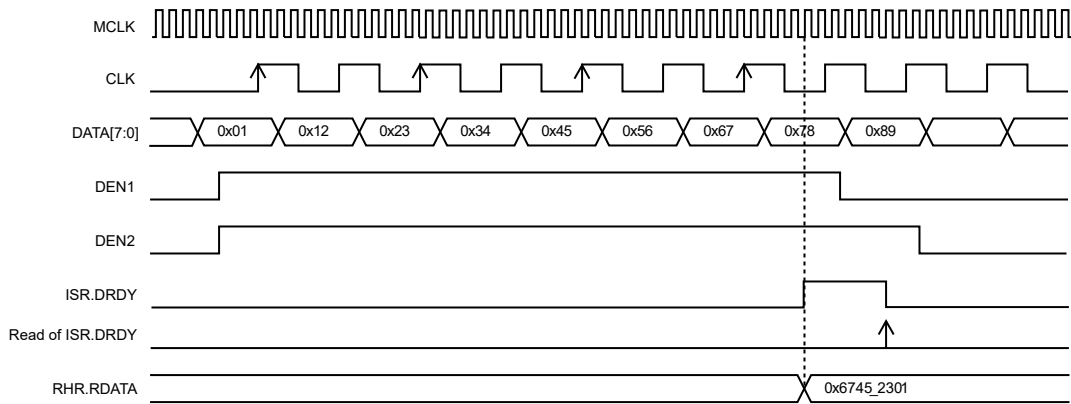
**Figure 52-7. PCC Waveforms (ISIZE=10\_BITS, DSIZE=2\_DATA, ALWAYS = 1, HALFS = 0, SCALE = 0)**



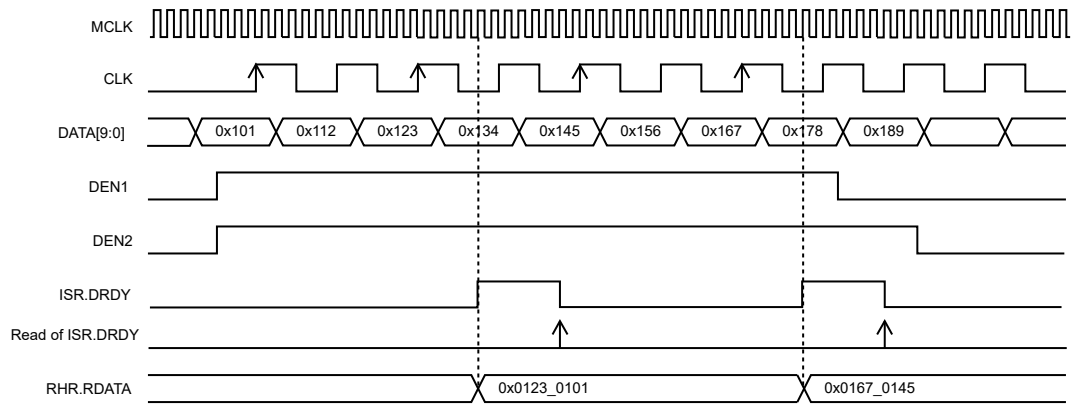
**Figure 52-8. PCC Waveforms (ISIZE=10\_BITS, DSIZE=2\_DATA, ALWAYS = 1, HALFS = 0, SCALE = 1)**



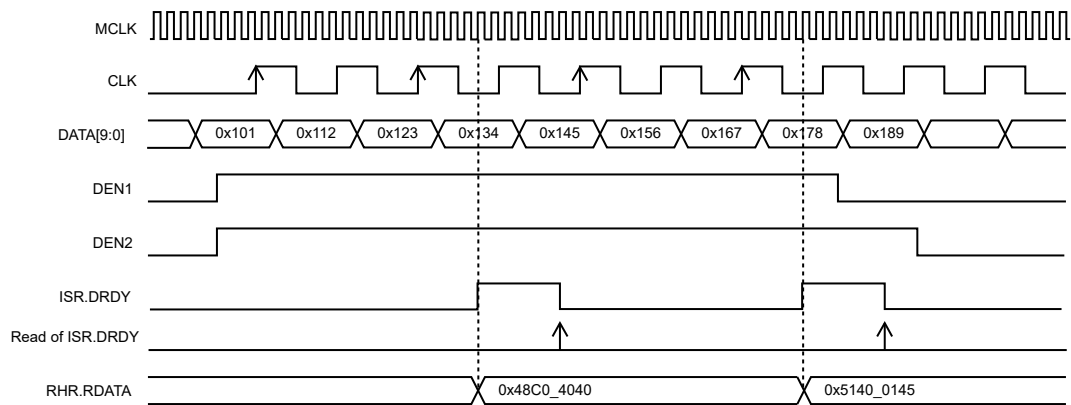
**Figure 52-9. PCC Waveforms (DSIZE=4\_DATA, ALWAYS = 0, HALFS = 1, FRSTS = 0)**



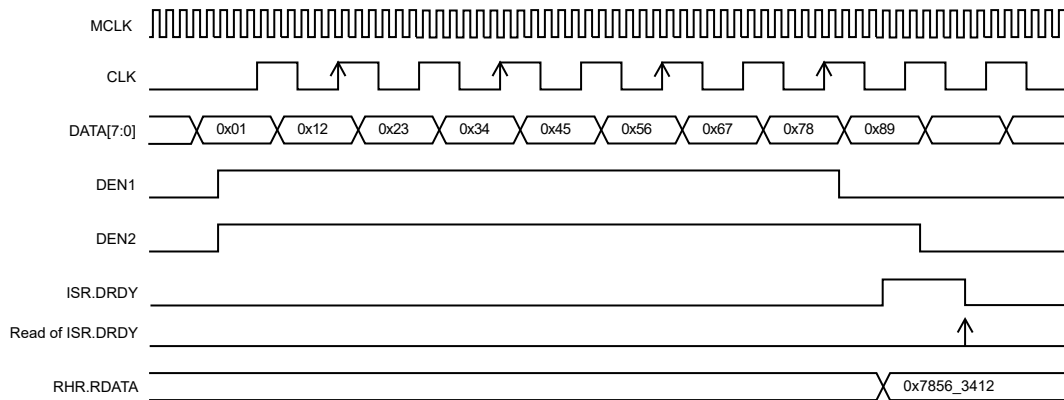
**Figure 52-10. PCC Waveforms (ISIZE=10\_BITS, DSIZE=2\_DATA, ALWAYS = 0, HALFS = 1, FRSTS = 0, SCALE = 0)**



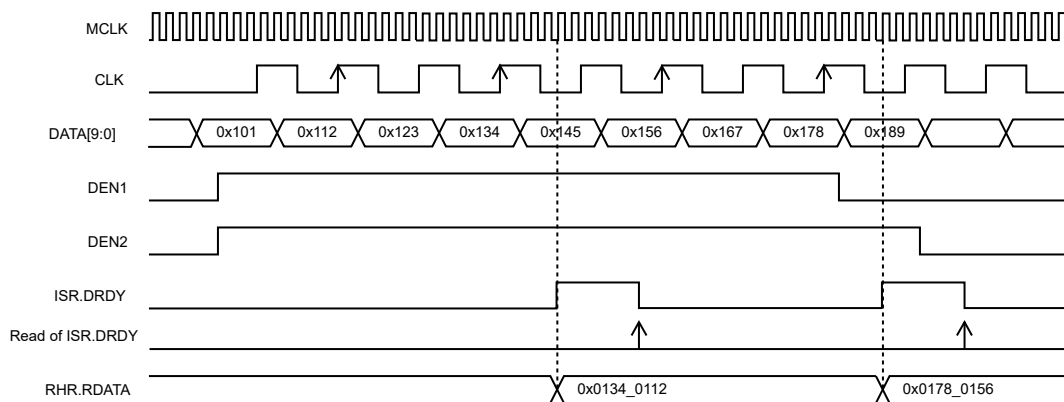
**Figure 52-11. PCC Waveforms (ISIZE=10\_BITS, DSIZE=2\_DATA, ALWAYS = 0, HALFS = 1, FRSTS = 0, SCALE = 1)**



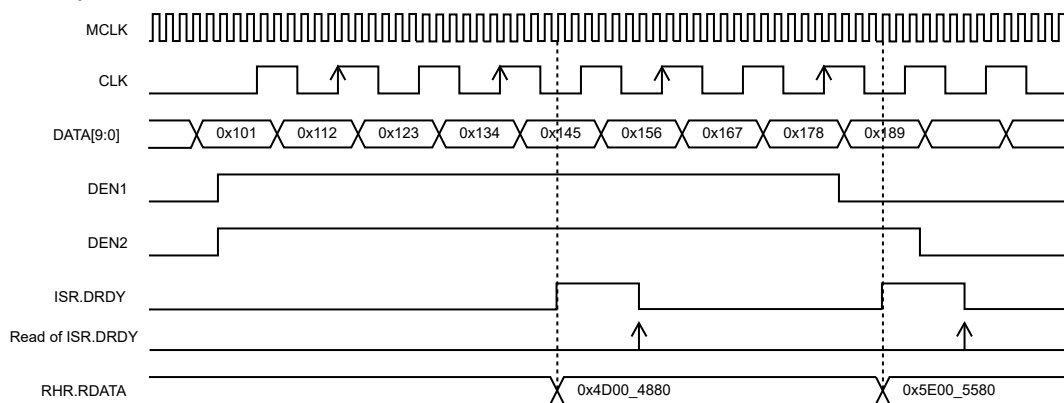
**Figure 52-12. PCC Waveforms (DSIZE=4\_DATA, ALWAYS = 0, HALFS = 1, FRSTS = 1)**



**Figure 52-13. PCC Waveforms (ISIZE=10\_BITS, DSIZE=2\_DATA, ALWAYS = 0, HALFS = 1, FRSTS = 1, SCALE = 0)**



**Figure 52-14. PCC Waveforms (ISIZE=10\_BITS, DSIZE=2\_DATA, ALWAYS = 0, HALFS = 1, FRSTS = 1, SCALE = 1)**



### 52.6.2 Register Access Protection

The configuration bit fields ISIZE, SCALE, DSIZE, ALWAYS, HALFS and FRSTS in the Mode Register (MR) can be changed ONLY if the PCC is disabled at this time (MR.PCEN=0).

### 52.6.3 Programming Sequence

#### 52.6.3.1 Without DMAC

1. Write the Interrupt Enable and Interrupt Disable Registers (IER and IDR) in order to configure the PCC interrupt mask.
2. Write the Mode Register (MR) fields ISIZE, SCALE, DSIZE, ALWAYS, HALFS and FRSTS in order to configure the PCC. Do not enable the PCC in this write access.
3. Write the PCC Enable bit in the Mode Register (MR.PCEN) to '1' in order to enable the PCC. Do not change the configuration from the previous step.
4. Wait for a Data Ready, either by polling the Data Ready flag in the Interrupt Status Register (ISR.DRDY) or by waiting for the corresponding interrupt.
5. Check the Overrun Error flag (ISR.OVRE).
6. Read the data in the Reception Holding Register (RHR).
7. If new data are expected, go to step 4.
8. Disable the PCC by writing MR.PCEN to '0' *without* changing the configuration.

#### 52.6.3.2 With DMAC

1. Write the Interrupt Enable and Interrupt Disable Registers (IER and IDR) in order to configure the PCC interrupt mask.
2. Configure DMAC transfer in the DMAC registers.
3. Write the Mode Register (MR) fields ISIZE, SCALE, DSIZE, ALWAYS, HALFS and FRSTS in order to configure the PCC. Do not enable the PCC in this write access.
4. Write the PCC Enable bit in the Mode Register (MR.PCEN) to '1' in order to enable the PCC. Do not change the configuration from the previous step.
5. Wait for end of transfer, indicated by the interrupt corresponding the End Receive flag in the Interrupt Status Register (ISR.ENDRX).
6. Check the Overrun Error flag (ISR.OVRE).
7. If a new buffer transfer is expected, go to step 5.
8. Disable the PCC by writing MR.PCEN to '0' *without* changing the configuration.

# SAM D5x/E5x Family Data Sheet

## PCC - Parallel Capture Controller

### 52.7 Register Summary

Offset	Name	Bit Pos.							
0x00	MR	7:0			DSIZE[1:0]				PCEN
		15:8				FRSTS	HALFS	ALWYS	SCALE
		23:16						ISIZE[2:0]	
		31:24	CID[1:0]						
0x04	IER	7:0				RXBUF	ENDRX	OVRE	DRDY
		15:8							
		23:16							
		31:24							
0x08	IDR	7:0				RXBUFF	ENDRX	OVRE	DRDY
		15:8							
		23:16							
		31:24							
0x0C	IMR	7:0				RXBUFF	ENDRX	OVRE	DRDY
		15:8							
		23:16							
		31:24							
0x10	ISR	7:0				RXBUFF	ENDRX	OVRE	DRDY
		15:8							
		23:16							
		31:24							
0x14	RHR	7:0	RDATA[7:0]						
		15:8	RDATA[15:8]						
		23:16	RDATA[23:16]						
		31:24	RDATA[31:24]						
0x18 ... 0xDF	Reserved								
0xE0	WPMR	7:0							WPEN
		15:8	WPKEY[7:0]						
		23:16	WPKEY[15:8]						
		31:24	WPKEY[23:16]						
0xE4	WPSR	7:0							WPVS
		15:8	WPVSR[7:0]						
		23:16	WPVSR[15:8]						
		31:24							

### 52.8 Register Description

Registers can be 8, 16, or 32 bits wide. Atomic 8-, 16- and 32-bit accesses are supported. In addition, the 8-bit quarters and 16-bit halves of a 32-bit register, and the 8-bit halves of a 16-bit register can be accessed directly.

# SAM D5x/E5x Family Data Sheet

## PCC - Parallel Capture Controller

---

---

Some registers are optionally write-protected by the Peripheral Access Controller (PAC). Optional PAC write protection is denoted by the "PAC Write-Protection" property in each individual register description. For details, refer to [52.6.2 Register Access Protection](#).

Some registers are enable-protected, meaning they can only be written when the peripheral is disabled. Enable-protection is denoted by the "Enable-Protected" property in each individual register description.

# SAM D5x/E5x Family Data Sheet

## PCC - Parallel Capture Controller

### 52.8.1 PCC Mode Register

**Name:** MR  
**Offset:** 0x00  
**Reset:** 0x00000000  
**Property:** -

This register can only be written if the WPEN bit is cleared in the Write Protection Mode Register.

Bit	31	30	29	28	27	26	25	24
	CID[1:0]							
Access	R/W	R/W						
Reset	0	0						
Bit	23	22	21	20	19	18	17	16
						ISIZE[2:0]		
Access						R/W	R/W	R/W
Reset						0	0	0
Bit	15	14	13	12	11	10	9	8
					FRSTS	HALFS	ALWYS	SCALE
Access					R/W	R/W	R/W	R/W
Reset					0	0	0	0
Bit	7	6	5	4	3	2	1	0
			DSIZE[1:0]					PCEN
Access			R/W	R/W				R/W
Reset			0	0				0

#### Bits 31:30 – CID[1:0] Clear If Disabled

Clears status flags if disabled. These bits are useful to re-initialize the internal mechanism of the PCC to avoid corrupted data due to glitches. Each time a falling edge of the selected DEN1 or DEN2 signal is detected, the internal mechanism of the PCC is re-initialized to avoid alignment issues.

Value	Description
0x0	Clear not enabled
0x1	Clear on falling edge on DEN1 enabled
0x2	Clear on falling edge on DEN2 enabled
0x3	Clear on falling edge on either DEN1 or DEN2 enabled

#### Bits 18:16 – ISIZE[2:0] Input Data Size

Value	Name	Description
0x0	8_BITS	Input data bus size is 8 bits
0x1	10_BITS	Input data bus size is 10 bits
0x2	12_BITS	Input data bus size is 12 bits
0x3	14_BITS	Input data bus size is 14 bits

#### Bit 11 – FRSTS First Sample

This bit is useful only if the HALFS bit is set to 1. If data are numbered in the order that they are received with an index from 0 to n.



# SAM D5x/E5x Family Data Sheet

## PCC - Parallel Capture Controller

Value	Description
0	Only data with an even index are sampled.
1	Only data with an odd index are sampled.

### Bit 10 – HALFS Half Sampling

This function is independent from the ALWAYS bit.

Value	Description
0	The Parallel Capture Controller samples all the data.
1	The Parallel Capture Controller samples the data only every other time.

### Bit 9 – ALWAYS Always Sampling

Value	Description
0	The parallel capture Controller samples the data when both data enables are active.
1	The parallel capture controller always samples the data, regardless of the state of data enable.

### Bit 8 – SCALE Scale Data

Value	Description
0	No effect.
1	When input data size is not equal to 8 bits ( $ISIZE \neq 0$ ), the data stored in the PCC_RHR is automatically up-scaled to 16 bits.

### Bits 5:4 – DSIZE[1:0] Data Size

Value	Name	Description
0x0	1_DATA	1 data is read in the PCC_RHR
0x1	2_DATA	2 data are read in the PCC_RHR
0x2	4_DATA	4 data are read in the PCC_RHR (only for 8 bits data size, $ISIZE = 0$ )
0x3		Reserved

### Bit 0 – PCEN Parallel Capture Enable

Value	Description
0	The Parallel Capture Controller is disabled.
1	The Parallel Capture Controller is enabled.

### 52.8.2 Interrupt Enable Register

**Name:** IER  
**Offset:** 0x04  
**Reset:** 0x00000000  
**Property:** -

Bit	31	30	29	28	27	26	25	24
Access								
Reset								
Bit	23	22	21	20	19	18	17	16
Access								
Reset								
Bit	15	14	13	12	11	10	9	8
Access								
Reset								
Bit	7	6	5	4	3	2	1	0
					RXBUF	ENDRX	OVRE	DRDY
Access					W	W	W	W
Reset					0	0	0	0

**Bit 3 – RXBUF** Reception Buffer Full Interrupt Enable.  
 Writing a '1' to this register enables the Reception Buffer Full interrupt.  
 Writing a '0' has no effect.

**Bit 2 – ENDRX** End of Reception Transfer Interrupt Enable  
 Writing a '1' to this register enables the End of Reception Transfer interrupt.  
 Writing a '0' has no effect.

**Bit 1 – OVRE** Overrun Error Interrupt Enable  
 Writing a '1' to this register enables the Overrun Error interrupt.  
 Writing a '0' has no effect.

**Bit 0 – DRDY** Data Ready Interrupt Enable  
 Writing a '1' to this register enables the Data Ready Interrupt interrupt.  
 Writing a '0' has no effect.

### 52.8.3 Interrupt Disable Register

**Name:** IDR  
**Offset:** 0x08  
**Reset:** 0x00000000  
**Property:** -

Bit	31	30	29	28	27	26	25	24
Access								
Reset								
Bit	23	22	21	20	19	18	17	16
Access								
Reset								
Bit	15	14	13	12	11	10	9	8
Access								
Reset								
Bit	7	6	5	4	3	2	1	0
					RXBUFF	ENDRX	OVRE	DRDY
Access					W	W	W	W
Reset					0	0	0	0

**Bit 3 – RXBUFF** Reception Buffer Full Interrupt Disable  
 Writing a '1' to this register disables the Reception Buffer Full interrupt.  
 Writing a '0' has no effect.

**Bit 2 – ENDRX** End of Reception Transfer Interrupt Disable  
 Writing a '1' to this register disables the End of Reception Transfer interrupt.  
 Writing a '0' has no effect.

**Bit 1 – OVRE** Overrun Error Interrupt Disable  
 Writing a '1' to this register disables the Overrun Error interrupt.  
 Writing a '0' has no effect.

**Bit 0 – DRDY** Data Ready Interrupt Disable  
 Writing a '1' to this register disables the Data Ready interrupt.  
 Writing a '0' has no effect.

# SAM D5x/E5x Family Data Sheet

## PCC - Parallel Capture Controller

### 52.8.4 Interrupt Mask Register

**Name:** IMR  
**Offset:** 0x0C  
**Reset:** 0x00000000  
**Property:** -

Bit	31	30	29	28	27	26	25	24
Access								
Reset								
Bit	23	22	21	20	19	18	17	16
Access								
Reset								
Bit	15	14	13	12	11	10	9	8
Access								
Reset								
Bit	7	6	5	4	3	2	1	0
					RXBUFF	ENDRX	OVRE	DRDY
Access					R	R	R	R
Reset					0	0	0	0

#### Bit 3 – RXBUFF Reception Buffer Full Interrupt Mask

Value	Description
1	The Reception Buffer Full interrupt is enabled.
0	The Reception Buffer Full interrupt is not enabled.

#### Bit 2 – ENDRX End of Reception Transfer Interrupt Mask

Value	Description
1	The End of Reception Transfer interrupt is enabled.
0	The End of Reception Transfer interrupt is not enabled.

#### Bit 1 – OVRE Overrun Error Interrupt Mask

Value	Description
1	The Overrun Error interrupt is enabled.
0	The Overrun Error interrupt is not enabled.

#### Bit 0 – DRDY Data Ready Interrupt Mask

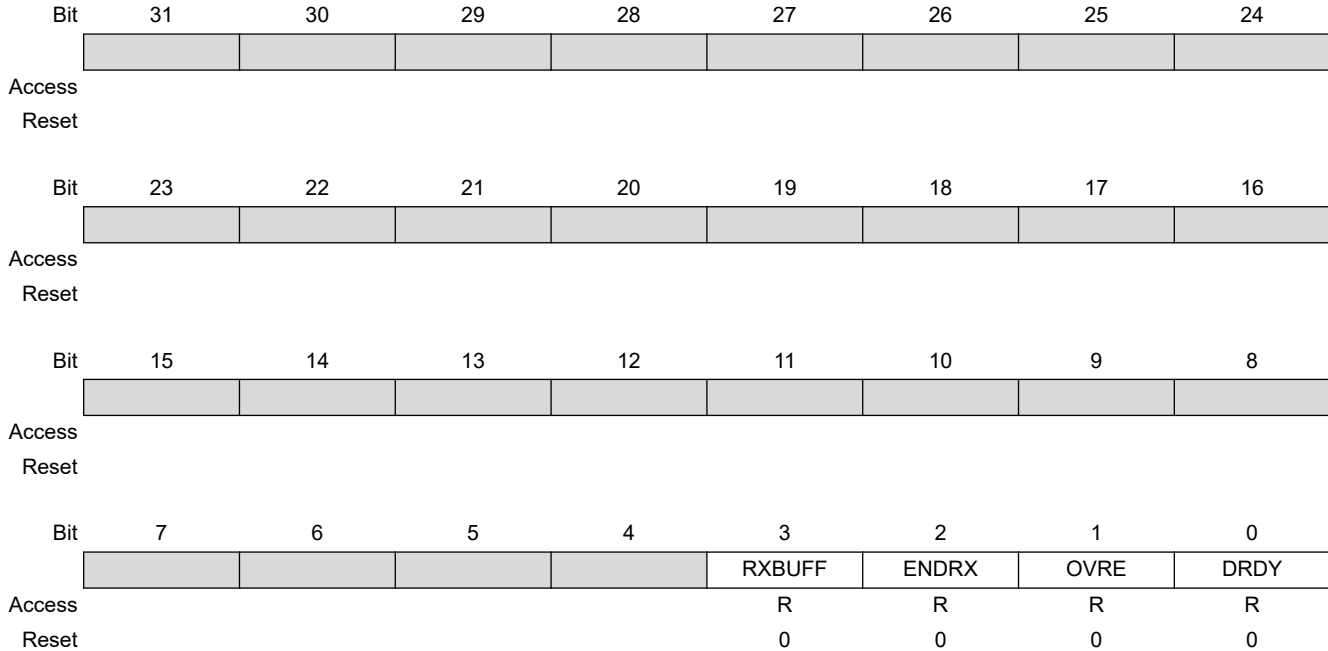
Value	Description
1	The Data Ready interrupt is enabled.
0	The Data Ready interrupt is not enabled.

# SAM D5x/E5x Family Data Sheet

## PCC - Parallel Capture Controller

### 52.8.5 Interrupt Status Register

**Name:** ISR  
**Offset:** 0x10  
**Reset:** 0x00000000  
**Property:** -



#### Bit 3 – RXBUFF Reception Buffer Full

Value	Description
0	The signal Buffer Full from the reception PDC channel is inactive.
1	The signal Buffer Full from the reception PDC channel is active.

#### Bit 2 – ENDRX End of Reception Transfer

Value	Description
0	The End of Transfer signal from the reception PDC channel is inactive.
1	The End of Transfer signal from the reception PDC channel is active.

#### Bit 1 – OVRE Overrun Error Interrupt Status

The OVRE flag is automatically reset when this register is read or when the PCC is disabled.

Value	Description
0	No overrun error occurred since the last read of this register.
1	At least one overrun error occurred since the last read of this register.

#### Bit 0 – DRDY Data Ready Interrupt Status

The DRDY flag is automatically reset when RHR is read or when the PCC is disabled.

Value	Description
0	No new data is ready to be read since the last read of RHR.
1	New data is ready to be read since the last read of RHR.

# SAM D5x/E5x Family Data Sheet

## PCC - Parallel Capture Controller

### 52.8.6 Reception Holding Register

**Name:** RHR  
**Offset:** 0x14  
**Reset:** 0x00000000  
**Property:** -

	Bit	31	30	29	28	27	26	25	24
		RDATA[31:24]							
Access		R	R	R	R	R	R	R	R
Reset		0	0	0	0	0	0	0	0
	Bit	23	22	21	20	19	18	17	16
		RDATA[23:16]							
Access		R	R	R	R	R	R	R	R
Reset		0	0	0	0	0	0	0	0
	Bit	15	14	13	12	11	10	9	8
		RDATA[15:8]							
Access		R	R	R	R	R	R	R	R
Reset		0	0	0	0	0	0	0	0
	Bit	7	6	5	4	3	2	1	0
		RDATA[7:0]							
Access		R	R	R	R	R	R	R	R
Reset		0	0	0	0	0	0	0	0

#### Bits 31:0 – RDATA[31:0] Reception Data

ISIZE	SCALE	DSIZE	Description
8_BITS	-	1_DATA	RDATA[7:0] is useful
		2_DATA	RDATA[15:0] is useful
		4_DATA	RDATA[31:0] is useful
10_BITS	0 (OFF)	1_DATA	RDATA[9:0] is useful
		2_DATA	RDATA[9:0] and RDATA[25:16] are useful
	1 (ON)	1_DATA	RDATA[15:0] is useful
		2_DATA	RDATA[31:0] is useful
12_BITS	0 (OFF)	1_DATA	RDATA[11:0] is useful
		2_DATA	RDATA[11:0] and RDATA[27:16] are useful
	1 (ON)	1_DATA	RDATA[15:0] is useful
		2_DATA	RDATA[31:0] is useful

# SAM D5x/E5x Family Data Sheet

## PCC - Parallel Capture Controller

.....continued

ISIZE	SCALE	DSIZE	Description
14_BITS	0 (OFF)	1_DATA	RDATA[13:0] is useful
		2_DATA	RDATA[13:0] and RDATA[29:16] are useful
	1 (ON)	1_DATA	RDATA[15:0] is useful
		2_DATA	RDATA[31:0] is useful

# SAM D5x/E5x Family Data Sheet

## PCC - Parallel Capture Controller

### 52.8.7 Write Protection Mode Register

**Name:** WPMR  
**Offset:** 0xE0  
**Reset:** 0x00000000  
**Property:** -

Bit	31	30	29	28	27	26	25	24
WPKEY[23:16]								
Access	R/W	R/W	R/W	R/W	R/W	R/W	R/W	R/W
Reset	0	0	0	0	0	0	0	0
Bit	23	22	21	20	19	18	17	16
WPKEY[15:8]								
Access	R/W	R/W	R/W	R/W	R/W	R/W	R/W	R/W
Reset	0	0	0	0	0	0	0	0
Bit	15	14	13	12	11	10	9	8
WPKEY[7:0]								
Access	R/W	R/W	R/W	R/W	R/W	R/W	R/W	R/W
Reset	0	0	0	0	0	0	0	0
Bit	7	6	5	4	3	2	1	0
								WPEN
Access								R/W
Reset								0

#### Bits 31:8 – WPKEY[23:0] Write Protection Key

Value	Name	Description
0x504343	PASSWD	Writing any other value in this field aborts the write operation of the WPEN bit.
3		Always reads as 0.

#### Bit 0 – WPEN Write Protection Enable

Value	Description
0	Disables the write protection if WPKEY corresponds to 0x504343 (“PCC” in ASCII).
1	Enables the write protection if WPKEY corresponds to 0x504343 (“PCC” in ASCII).



# SAM D5x/E5x Family Data Sheet

## PCC - Parallel Capture Controller

### 52.8.8 Write Protection Status Register

**Name:** WPSR  
**Offset:** 0xE4  
**Reset:** 0x00000000  
**Property:** -

	Bit	31	30	29	28	27	26	25	24
Access									
Reset									
	Bit	23	22	21	20	19	18	17	16
		WPVSR[15:8]							
Access		R	R	R	R	R	R	R	R
Reset		0	0	0	0	0	0	0	0
	Bit	15	14	13	12	11	10	9	8
		WPVSR[7:0]							
Access		R	R	R	R	R	R	R	R
Reset		0	0	0	0	0	0	0	0
	Bit	7	6	5	4	3	2	1	0
									WPVS
Access									R
Reset									0

**Bits 23:8 – WPVSR[15:0]** Write Protection Violation Source

When WPVS = 1, WPVSR indicates the register address offset at which a write access has been attempted.

**Bit 0 – WPVS** Write Protection Violation Status

Value	Description
0	No write protection violation has occurred since the last read of the WPSR.
1	A write protection violation has occurred since the last read of the WPSR. If this violation is an unauthorized attempt to write a protected register, the associated violation is reported into field WPVSR.

### 53. PDEC – Position Decoder

#### 53.1 Overview

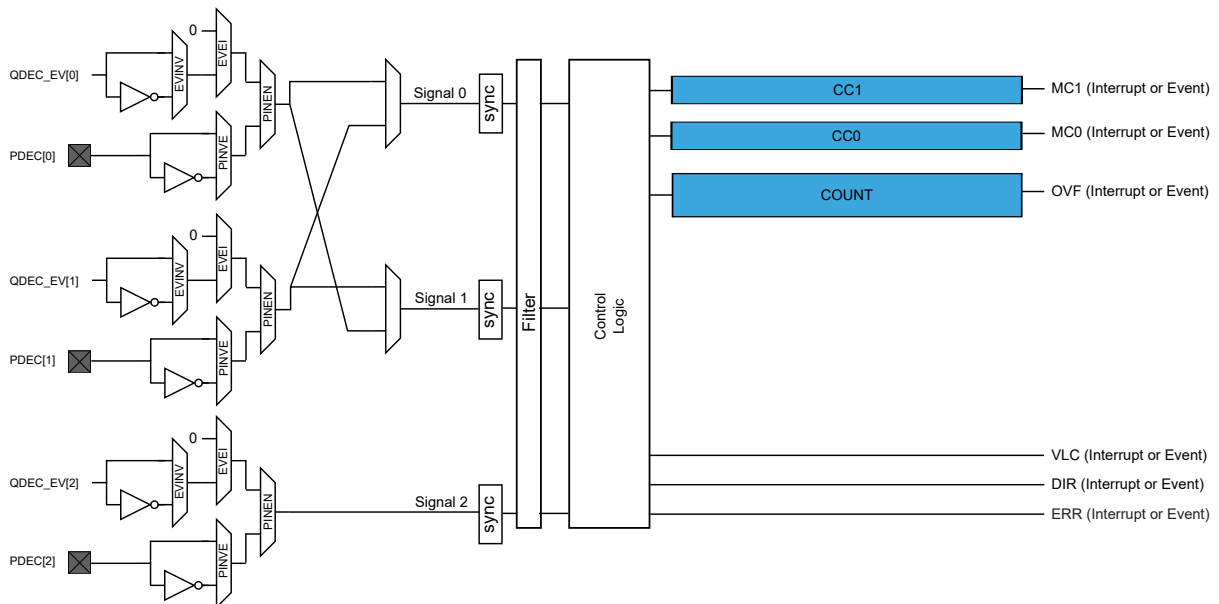
The PDEC consists of a Quadrature / Hall decoder, following by a counter, with two compare channels. The counter can be split into two parts to report the angular position and the number of revolutions. If the quadrature decoder feature is not suitable for specific applications, the PDEC module can be used as an additional time base.

#### 53.2 Features

- Internal prescaler
- Selectable mode of operation:
  - QDEC, HALL or COUNTER
- QDEC
  - Angular and revolution counts
  - Synchronous and asynchronous velocity measurements
  - Direction change detection
  - Check valid quadrature transitions
  - Check index position versus angular position
  - Auto correction mode
- HALL
  - Window validation of Hall transitions
  - Hall code detection
  - Direction change detection
  - Check valid Hall transitions
  - Programmable event generation delay after a Hall transition
- COUNTER
  - 16-bit counter with two compare channels
  - One of the compare channels can be configured with period settings
  - Counter overflow interrupt and event generation option
  - Compare match interrupt and event generation option

### 53.3 Block Diagram

Figure 53-1. Block Diagram



### 53.4 Signal Description

Signal Name	Type	Description
PDEC[2:0]	Digital input	PDEC inputs

**Note:** One signal can be mapped on one of several pins.

#### Related Links

[6. I/O Multiplexing and Considerations](#)

### 53.5 Product Dependencies

In order to use this peripheral, other parts of the system must be configured correctly, as described below.

#### 53.5.1 I/O Lines

Using the I/O lines requires the I/O pins to be configured using the PORT configuration (PORT).

#### Related Links

[32. PORT - I/O Pin Controller](#)

#### 53.5.2 Power Management

The PDEC can be configured to operate in any sleep mode. The PDEC can wake up the device using interrupts from any sleep mode or perform actions through the Event System.

#### Related Links

### [18. PM – Power Manager](#)

#### **53.5.3 Clocks**

A generic clock (GCLK\_PDEC) is required to clock the PDEC. This clock must be configured and enabled in the generic clock controller before using the PDEC.

This generic clock is asynchronous to the bus clock (CLK\_PDEC\_APB). Due to this asynchronicity, writes to certain registers will require synchronization between the clock domains.

##### **Related Links**

[14. GCLK - Generic Clock Controller](#)

[13.3 Register Synchronization](#)

#### **53.5.4 DMA**

Not applicable.

#### **53.5.5 Interrupts**

The interrupt request line is connected to the Interrupt Controller. In order to use interrupt requests of this peripheral, the Interrupt Controller (NVIC) must be configured first. Refer to *Nested Vector Interrupt Controller* for details.

##### **Related Links**

[10.2 Nested Vector Interrupt Controller](#)

[10.2.1 Overview](#)

[10.2.2 Interrupt Line Mapping](#)

#### **53.5.6 Events**

The events of this peripheral are connected to the Event System.

##### **Related Links**

[31. EVSYS – Event System](#)

#### **53.5.7 Debug Operation**

When the CPU is halted in debug mode the PDEC will halt normal operation. The PDEC can be forced to continue operation during debugging. Refer to DBGCTRL register for details.

#### **53.5.8 Register Access Protection**

All registers with write access can be write-protected optionally by the Peripheral Access Controller (PAC), except for the following registers:

- Interrupt Flag register (INTFLAG)
- Filter register (FILTER)
- Prescaler register (PRESC)
- Compare x Value register (CCx)
- Channel x Compare Buffer Value register (CCBUFx)
- Status register (STATUS)

Optional write protection by the Peripheral Access Controller (PAC) is denoted by the "PAC Write Protection" property in each individual register description.

PAC write protection does not apply to accesses through an external debugger.

### Related Links

[27. PAC - Peripheral Access Controller](#)

### 53.5.9 Analog Connections

Not applicable.

## 53.6 Functional Description

### 53.6.1 Principle of Operation

The PDEC control logic can be driven by a set of three inputs signal coming from Event System channels or I/O input pins. These three inputs can be filtered prior to down-stream processing. The input polarity, phase definition and other factors are configurable. QDEC, HALL or COUNTER mode of operation are supported.

Depending of the mode configuration, specific input sequences can generate:

- State change
- Counter increment or decrement
- Interrupts
- Output events

### 53.6.2 Basic Operation

#### 53.6.2.1 Initialization

The following PDEC registers are enable-protected, meaning they can only be written when the PDEC is disabled (CTRLA.ENABLE is zero):

- Event Control register (EVCTRL)

Enable-protected bits in the CTRLA register can be written at the same time as CTRLA.ENABLE is written to '1', but not at the same time as CTRLA.ENABLE is written to '0'.

Enable-protection is denoted by the 'Enable-Protected' property in the register description.

#### 53.6.2.2 Enabling, Disabling, and Resetting

The PDEC must be configured before it is enabled by the following steps:

1. Enable the PDEC bus clock (CLK\_PDEC\_APB)
2. Select the mode of operation by writing the Mode bits in the Control A register (CTRLA.MODE)
3. Select the PDEC mode configuration by writing the Configuration bits in the Control A register (CTRLA.CONF)
4. Select the PDEC event or pin input signal source by writing the Event Enable Input bit in the Event Control register (EVCTRL.EVEI) or by the Pin Enable bit in Control A register (CTRLA.PINEN)
5. Select the angular counter length value by writing the Angular bits in the Control A register (CTRLA.ANGULAR)

Optionally, the following configurations can be set before enabling PDEC:

- The GCLK\_PDEC clock can be prescaled by writing to the Prescaler register (PRESC)
- A filter can be applied to the input signal by writing a corresponding value to the Filter register (FILTER)
- If the resolution of the rotary sensor is not a power of 2, an Angular period can be set (CTRLA.PEREN and CC0 register)

The PDEC is enabled by writing a '1' to the Enable bit in the Control A register (CTRLA.ENABLE). The PDEC is disabled by writing a '0' to CTRLA.ENABLE.

In QDEC or HALL operation modes, PDEC decoding is enabled writing a START command in the Control B Set register (CTRLBSET.CMD=START). The PDEC decoding is disabled writing a STOP command in the Control B Set register (CTRLBSET.CMD=STOP).

The PDEC is reset by writing a '1' to the Software Reset bit in the Control A register (CTRLA.SWRST). All registers in the PDEC, except DBGCTRL, will be reset to their initial state, and the PDEC will be disabled.

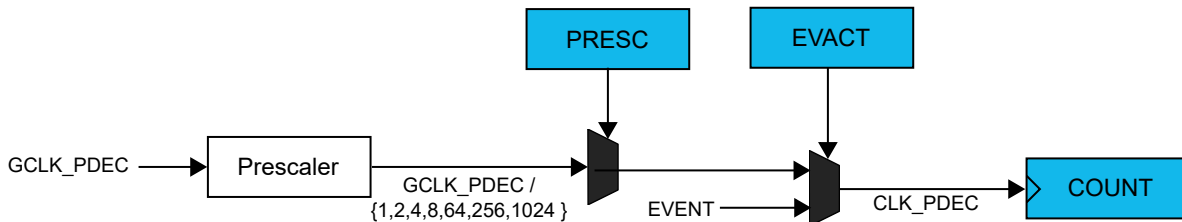
The PDEC should be disabled before the PDEC is reset to avoid undefined behavior.

### 53.6.2.3 Prescaler Selection

The GCLK\_PDEC is fed into the internal prescaler. Prescaler outputs from 1 to 1/1024 are directly available for selection by the counter and all selections are available in Prescaler register (PRESC). If the prescaler value is higher than 0x01, the counter update condition is executed on the next prescaled clock pulse.

If the counter is set to count events, the internal prescaler is bypassed and the GCLK\_PDEC clock is automatically selected during operation. The prescaler clock is also enabled when the input filtering is required.

**Figure 53-2. Prescaler Selection**



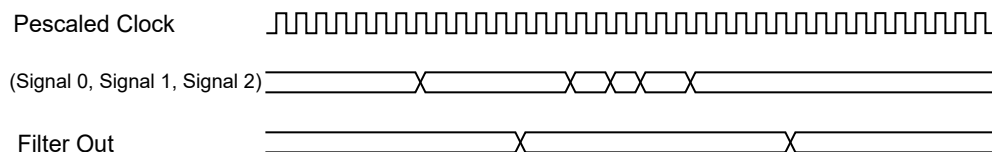
### 53.6.2.4 Input Selection and Filtering

The QDEC and HALL operations require three inputs, as shown in the Block Diagram. Each input can either be a dedicated I/O pin or an Event system channel. This is selected by writing to the corresponding Event x Enable bit in the Event Control register (EVCTRL.EVEIx) or Pin x Enable bit in the Control A register (CTRLA.PINENx).

The I/O input pin active level can be inverted by writing to the corresponding Pin x Inversion Enable bit in Control A register (CTRLA.PINVENx). In the same way, the event input active level can be inverted by writing to the corresponding Inverted Event x Input Enable bit in Event Control register (EVCTRL.EVINVx).

All input signals can be filtered before they are fed into the control logic. The FILTER register is used to configure the minimum duration for which the input signal has to be valid. The input signal minimum duration must be  $FILTER * t_{GCLK\_PDEC}$ .

**Figure 53-3. Input Signal Filtering**



Only the first two input signals can be swapped by writing to the SWAP bit in the Control A register (CTRLA.SWAP).

### Related Links

[53.3 Block Diagram](#)

#### 53.6.2.5 Period Control

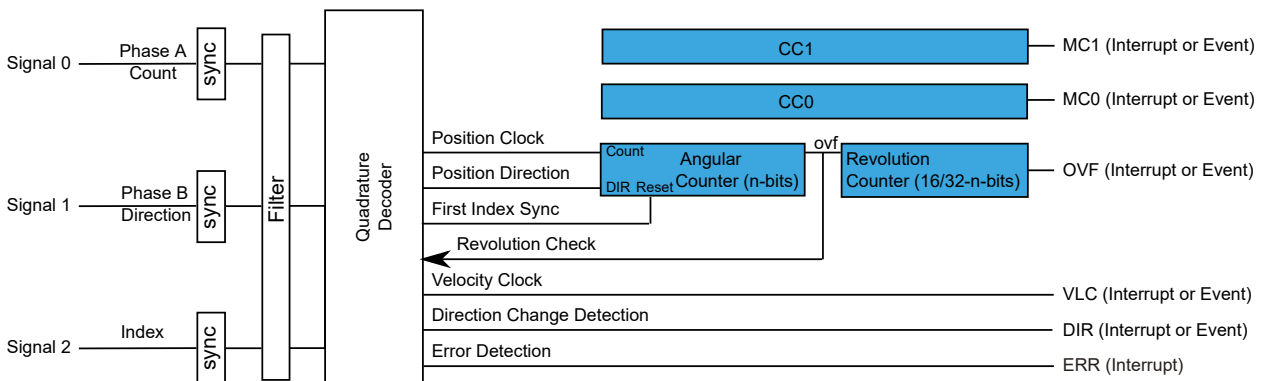
The Channel Compare 0 register (CC0) can act as a period register (PER) by writing the PEREN bit in the Control A register (CTRLA.PEREN) to '1'. The PER can be used to control the top value (TOP) of the counting operation:

When up-counting and the counter reaches the value of CC0, the counter is cleared to zero. When down-counting and the counter reaches zero, the counter is reloaded with the CC0 value.

#### 53.6.2.6 QDEC Operation Mode

In QDEC mode of operation, Signal 0 and Signal 1 control logic inputs refer to Phase A and Phase B in X4 mode, and to count/direction in X2 mode. The Signal 2 control logic input refers to the Index, in both X4 and X2 mode of operation. In X4 mode, a simultaneous transition on Phase A and Phase B will cause a QDEC error detection (STATUS.QERR).

**Figure 53-4. QDEC Block Diagram**



### Related Links

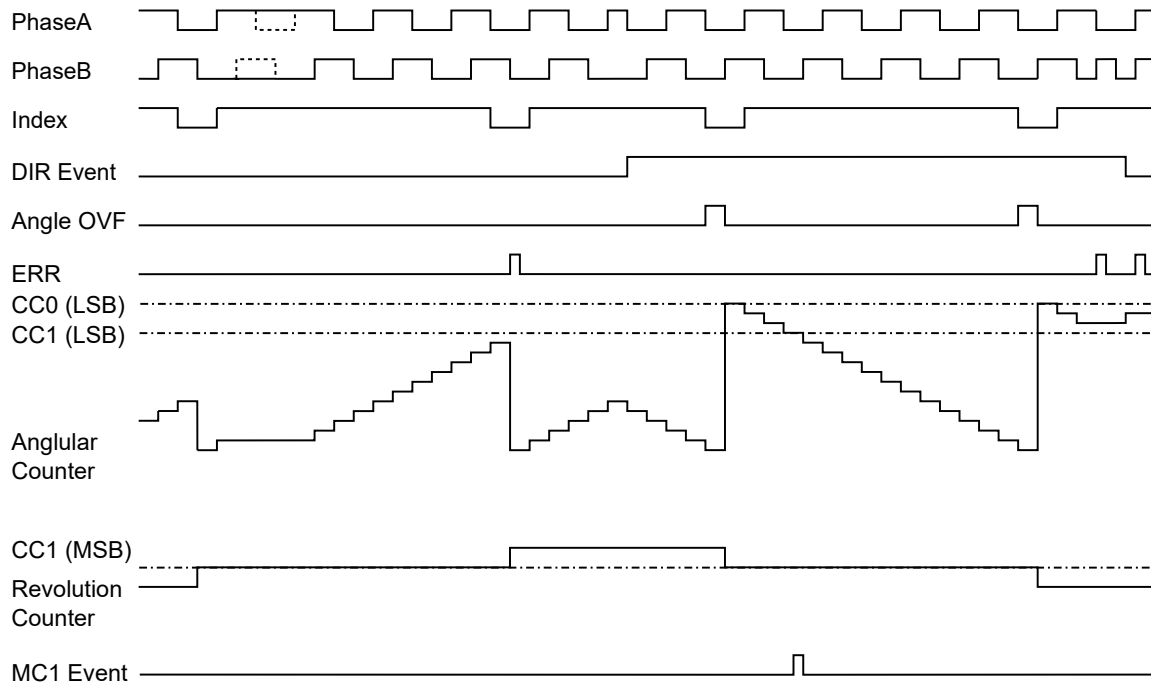
[53.3 Block Diagram](#)

#### 53.6.2.6.1 Position and Rotation Measurement

After filtering, the quadrature signals are analyzed to extract the rotation direction and edges in order to be counted by the counter.

The counter is split in two parts, Angular and Revolution. The Phase A and B edge detections define the motor axis position, which is recorded by the Angular part of the counter. The motor revolution is recorded by the Revolution part of the counter. The Angular counter is updated each time a QDEC transition is detected. The Revolution counter is updated on each angular counter overflow or underflow.

**Figure 53-5. Position and Rotation Measurement**



in Q4 and Q4S configuration, a valid index is detected when the three inputs (PhaseA, PhaseB and Index) are at low level.

In Q2 and Q2S configuration, a valid index is detected when the two inputs (Count and Index) are at low level.

in Q2 and Q4 configuration, depending on current detected direction, Index will reset or reload the Angular counter and increment or decrement the Revolution counter.

In Q2S and Q4S configuration, the Angular counter is reset on the first Index occurrence after the PDEC decoding is enabled. When any next Index occurrence does not match an Angular counter overflow or underflow, the Index Error flag in Status register is set (STATUS.IDXERR). The Error Interrupt Flag is set (INTFLAG.ERR) and an optional interrupt can be generated.

An Index Error is also generated after the PDEC decoding is enabled and no Index has been detected after one Angular counter revolution.

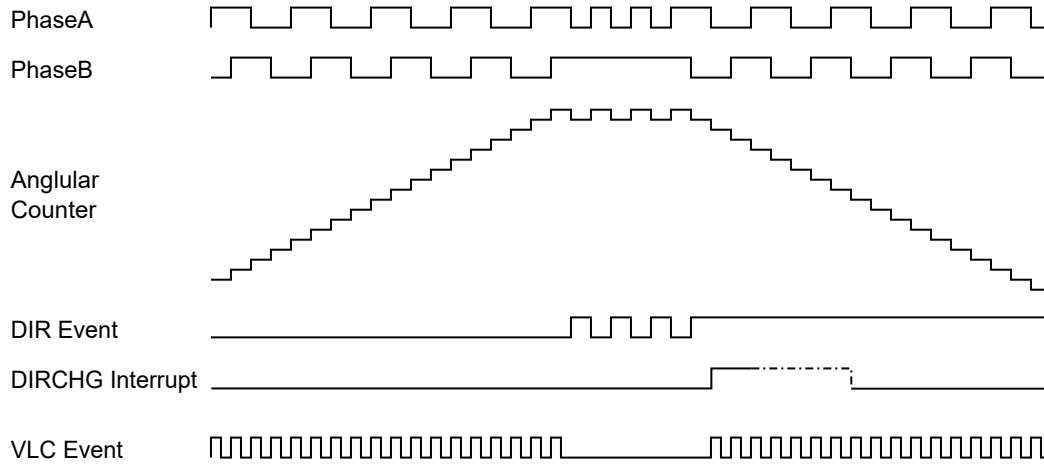
### 53.6.2.6.2 Direction Status and Change Detection

The direction (DIR) status can be directly read anytime in the STATUS register (STATUS.DIR). The polarity of the direction flag status depends of the input signal swap and active level configuration.

Each time a rotation direction change is detected, the Direction Change Interrupt Flag is set (INTFLAG.DIR) and an optional interrupt can be generated. The same interrupt condition is source of Direction event output.



**Figure 53-6. Rotation Direction Change**



To avoid spurious interrupts when coding wheel is stopped, the direction change condition is reported as an interrupt, only on the second edge confirming the direction change.

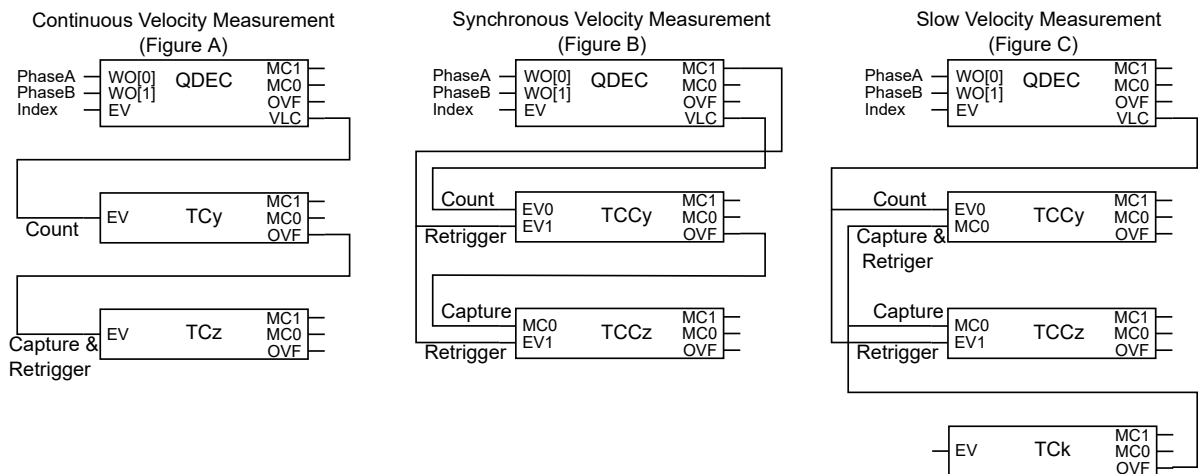
Velocity output event is generated on each QDEC transition except when the direction changes.

### 53.6.2.6.3 Speed Measurement

Three types of speed measurement can be done using velocity event output (VLC) and Timer/Counter (TC/TCC) device resources.

- Continuous velocity measurement: TCz measures the time on which n VLC (TCy) output events occur
- Synchronous Velocity measurement: On a specific motor position TCCz, the time is measured on which n VLC (TCCy) output events occur.
- Slow Velocity measurement: measure the number of VLC output events (TCCy) plus the delay since the last VLC output event (TCCz) within a given time slot (TCK).

**Figure 53-7. Speed Measurement**



### 53.6.2.6.4 Missing Pulse Detection and Auto-Correction

The PDEC embeds circuitry to detect and correct errors that may result from contamination on optical disks or other sources producing quadrature phase signals.

The auto-correction works in QDEC X4 mode only. A missing pulse on a phase signal is automatically detected, and the pulse count reported in the Angular part of COUNT is automatically corrected.

There is no autocorrection if both phase signals are affected at the same location on the input signals, because the autocorrection requires a valid phase signal to detect contamination on the other phase signal.

If the quadrature source is undamaged, the number of pulses counted for a predefined period of time must be the same with or without detection and auto-correction. Therefore, if the measurement results differ, a contamination exists on the source producing the quadrature signals. This does not substitute the measurements of the number of pulses between two index pulses (if available) but provides an additional method to detect damaged quadrature sources.

When the source providing quadrature signals is strongly damaged, potentially leading to a number of consecutive missing pulses greater than 1, the quadrature decoder processing may be affected.

The Maximum Consecutive Missing Pulses bits in Control A register (CTRLA.MAXCMP) define the maximum acceptable number of consecutive missing pulses. If the limit is reached, the Missing Pulse Error flag in Status register (STATUS.MPERR) is set. The Error Interrupt flag is set (INTFLAG.ERR) and an optional interrupt can be generated.

**Note:** When the MAXCMP value is zero, the MPERR error flag is never set.

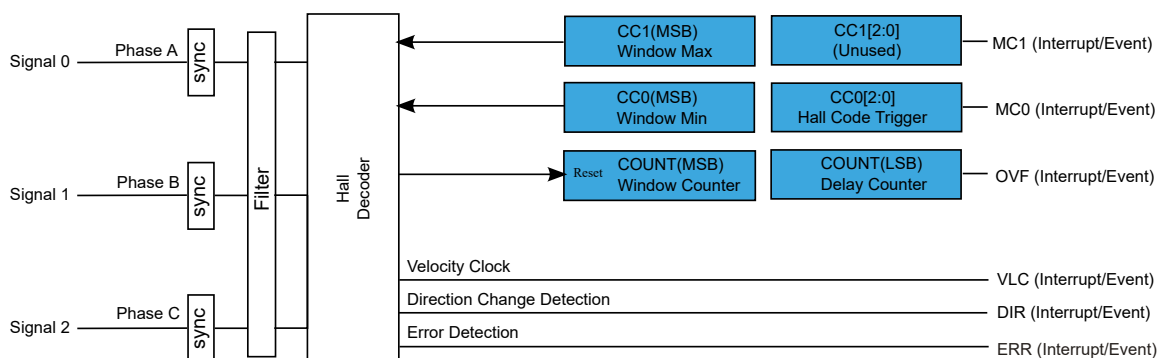
### 53.6.3 Additional Features

#### 53.6.3.1 HALL Operation Mode

In HALL operation mode, control logic signal 0, 1 and 2 inputs represent the phase A, B and C of a Hall sensor, respectively.

A programmable delayed event can be generated to update a TCC pattern generator.

**Figure 53-8. HALL Block Diagram**



### Related Links

[53.3 Block Diagram](#)

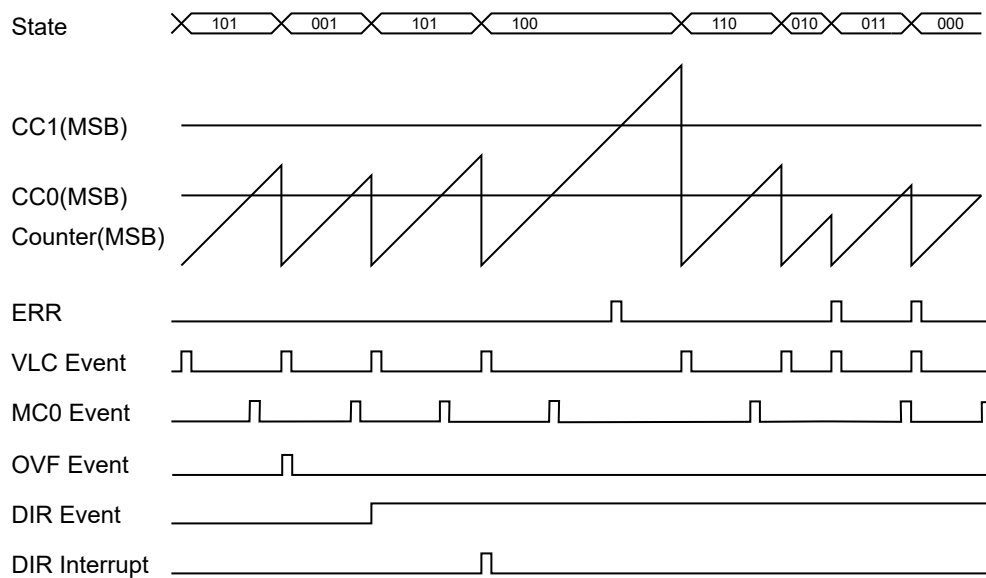
#### 53.6.3.1.1 Hall Sensor Control

On any update of the filter output:

- The filter output value is checked to be a valid Hall value. If an invalid Hall code is reported, the Hall Error bit in Status register will be set (STATUS.HERR).
- The MC0 Interrupt Flag bit is set (INTFLAG.MC0) if CC0[2:0] matches the filter output value. An optional compare match interrupt or Event output is generated on the same condition detection.
- The window counter is checked to be between CC0[MSB] and CC1[MSB] value, and reset to 0 value. If an error is detected, the Window Error bit in Status register (STATUS.WINERR) is set.
- The delay counter is started, and MC0 optional interrupt or event is generated when the delay counter matches CC0[LSB].

Any error condition will set the Error Interrupt Flag (INTFLAG.ERR). An optional interrupt or event output is generated on the same condition detection.

**Figure 53-9. Hall Waveforms**



### 53.6.3.2 Counter Operation Mode

Depending on the mode of operation, the counter (Counter Value register COUNT) is cleared, reloaded, or incremented at each counter clock input.

The counter will count for each clock tick until it reaches TOP. When TOP is reached, the counter will be set to zero on the next clock input.

This comparison will set the Overflow Interrupt Flag in the Interrupt Flag Status and Clear register (INTFLAG.OVF) and can be used to trigger an interrupt or an event.

It is possible to change the counter value when the counter is running. The write access has higher priority than count, or clear. The COUNT value will always be zero when starting the PDEC, unless a different value has been written to it, or the PDEC has been disabled at a value other than zero. Due to asynchronous clock domains, the internal counter settings are written once the synchronization is complete.

### Related Links

[14. GCLK - Generic Clock Controller](#)

### 53.6.3.3 Register Lock Update

Prescaler (PRESC), FILTER, and CCx registers are buffered (PRESCBUF, FILTERBUF, CCBUFx registers, respectively). When a new value is written in a buffer register, the corresponding Buffer Valid bit is set in the Buffer Status register (STATUS.FILTERBUFV, STATUS.PRESCBUFV, STATUS.CCBUFVx).

By default, a register is updated with the its buffer register's value on UPDATE condition, which represents:

- The next filter transition in QDEC and HALL mode of operation
- The overflow/underflow or re-trigger event detection in COUNT mode of operation

The buffer valid flags in the STATUS register are automatically cleared by hardware when the data is copied from the buffer to the corresponding register.

It is possible to lock the updates by writing a '1' to the Lock Update bit in Control B Set register (CTRLBSET.LUPD).

The lock feature is disabled by writing a '1' to the Lock Update bit in Control B Clear register (CTRLBCLR.LUPD). When a buffer valid status flag is '1' and updating is not locked, the data from the buffer register will be copied into the corresponding register on UPDATE condition.

It is also possible to modify the LUPD bit behavior by hardware, by writing a '1' to the Auto-lock bit in Control A register (CTRLA.ALCK). When the bit is '1', the Lock Update bit in Control B register (CTRLBSET.LUPD) is set when the UPDATE condition is detected.

### 53.6.3.4 Software Command and Event Actions

The PDEC peripheral supports software commands and event actions. The software commands are applied by the Software Command bit field in the Control B register (CTRLBSET.CMD, CTRLBCLR.CMD). The event actions are available in the Event Action bit-field in Event Control register (EVCTRL.EVACT).

#### 53.6.3.4.1 Re-trigger Software Command or Event Action

A re-trigger command can be issued from software by using PDEC Command bits in Control B Set register (CTRLBSET.CMD = RETRIGGER) or when the re-trigger event action is configured in the Input Event Action bits in Event Control register (EVCTRL.EVACT = RETRIGGER) and an event is detected by hardware.

When the re-trigger command is detected during counting operation, the counter will be reloaded or cleared, depending on the counting direction (DIR). If the re-trigger command is detected when the counter is stopped, the counter will resume counting operation from the value in the COUNT register.

**Note:** When re-trigger event action is enabled, enabling the counter will not start the counter. The counter will start on the next incoming event and restart on any following event.

#### 53.6.3.4.2 Count Event Action

The count action can be selected in the Event Control register (EVCTRL.EVACT) and can be used to count external events. When an event is received, the counter increments the value.

#### 53.6.3.4.3 Force Update Software Command

A Force Update command can be issued by writing the PDEC Command bits in Control B Set register (CTRLBSET.CMD = UPDATE). When the command is issued, the buffered registers will be updated.

#### 53.6.3.4.4 Force Read Synchronization Software Command

A Force Read Synchronization command can be issued writing the PDEC Command bits in Control B Set register (CTRLBSET.CMD = READSYNC). When the command is issued, a COUNT register read synchronization is forced.

**Note:** This command should be used to read the most updated COUNT internal value.

### 53.6.4 Interrupts

The PDEC has the following interrupt sources:

- Overflow/Underflow: OVF
- Compare Channels: COMPx
- Error: ERR
- Velocity: VLC. This interrupt is available only in QDEC and HALL operation modes.
- Direction: DIR. This interrupt is available only in QDEC and HALL operation modes.

Each interrupt source has an interrupt flag associated with it. The interrupt flag in the Interrupt Flag Status and Clear register (INTFLAG) is set when the interrupt condition occurs. Each interrupt can be individually enabled by writing a '1' to the corresponding bit in the Interrupt Enable Set register (INTENSET), and disabled by writing a '1' to the corresponding bit in the Interrupt Enable Clear register (INTENCLR).

An interrupt request is generated when the interrupt flag is set and the corresponding interrupt is enabled. The interrupt request remains active until the interrupt flag is cleared, the interrupt is disabled or the PDEC is reset. See the INTFLAG register description for details on how to clear interrupt flags.

The user must read the INTFLAG register to determine which interrupt condition is present.

**Note:** Interrupts must be globally enabled for interrupt requests to be generated.

### 53.6.5 Events

The PDEC can generate the following output events:

- Overflow/Underflow: OVF
- Channel x Compare Match: MCx
- Error: ERR
- Velocity: VLC. This interrupt is available only in QDEC and HALL operation modes.
- Direction: DIR. This interrupt is available only in QDEC and HALL operation modes.

Writing a '1' to an Event Output bit in the Event Control register (EVCTRL.MCEO) enables the corresponding output event. Writing a '0' to this bit disables the corresponding output event.

#### Related Links

[31. EVSYS – Event System](#)

### 53.6.6 Sleep Mode Operation

The PDEC can be configured to operate in any sleep mode. To be able to run in standby, the RUNSTDBY bit in the Control A register (CTRLA.RUNSTDBY) must be written to '1'. The PDEC can wake up the device using interrupts from any sleep mode or perform actions through the Event System.

### 53.6.7 Synchronization

Due to asynchronicity between the main clock domain and the peripheral clock domains, some registers need to be synchronized when written or read.

The following bits are synchronized when written:

- Software Reset bit in the Control A register (CTRLA.SWRST)
- Enable bit in the Control A register (CTRLA.ENABLE)

The following registers need synchronization when written:

- Control B Clear and Control B Set registers (CTRLBCLR and CTRLBSET)
- Status register (STATUS)
- Prescaler and Prescaler Buffer registers (PRESC and PRESCBUF)
- Compare Value x and Compare Value x Buffer registers (CCx and CCBUFx)
- Filter Value and Filter Buffer Value registers (FILTER and FILTERBUF)
- Counter Value register (COUNT)

Required write synchronization is denoted by the "Write-Synchronized" property in the register description.

The following registers are synchronized when read:

- Counter Value register (COUNT): the synchronization is done on demand through READSYNC software command (CTRLBSET.CMD)

Required read synchronization is denoted by the "Read-Synchronized" property in the register description.

### Related Links

[13.3 Register Synchronization](#)

# SAM D5x/E5x Family Data Sheet

## PDEC – Position Decoder

### 53.7 Register Summary

Offset	Name	Bit Pos.								
0x00	CTRLA	7:0		RUNSTDBY			MODE[1:0]		ENABLE	SWRST
		15:8	PEREN	SWAP			ALOCK	CONF[2:0]		
		23:16		PINVEN2	PINVEN1	PINVEN0		PINEN2	PINEN1	PINEN0
		31:24	MAXCMP[3:0]					ANGULAR[2:0]		
0x04	CTRLBCLR	7:0	CMD[2:0]						LUPD	
0x05	CTRLBSET	7:0	CMD[2:0]						LUPD	
0x06	EVCTRL	7:0	EVEI[2:0]			EVINV[2:0]			EVACT[1:0]	
		15:8			MCEO1	MCEO0	VLCEO	DIREO	ERREO	OVFEO
0x08	INTENCLR	7:0			MC1	MC0	VLC	DIR	ERR	OVF
0x09	INTENSET	7:0			MC1	MC0	VLC	DIR	ERR	OVF
0x0A	INTFLAG	7:0			MC1	MC0	VLC	DIR	ERR	OVF
0x0B	Reserved									
0x0C	STATUS	7:0	DIR	STOP	HERR	WINERR		MPERR	IDXERR	QERR
		15:8			CCBUFV1	CCBUFV0			FILTERBUFV	PRESCBUFV
0x0E	Reserved									
0x0F	DBGCTRL	7:0								DBGRUN
0x10	SYNCBUSY	7:0	CC0	COUNT	FILTER	PRESC	STATUS	CTRLB	ENABLE	SWRST
		15:8								CC1
		23:16								
		31:24								
0x14	PRESC	7:0				PRESC[3:0]				
0x15	FILTER	7:0	FILTER[7:0]							
0x16	...									
0x17	Reserved									
0x18	PRESCBUF	7:0				PRESCBUF[3:0]				
0x19	FILTERBUF	7:0	FILTERBUF[7:0]							
0x1A	...									
0x1B	Reserved									
0x1C	COUNT	7:0	COUNT[7:0]							
		15:8	COUNT[15:8]							
		23:16								
		31:24								
0x20	CC0	7:0	CC[7:0]							
		15:8	CC[15:8]							
		23:16								
		31:24								
0x24	CC1	7:0	CC[7:0]							
		15:8	CC[15:8]							
		23:16								
		31:24								

.....continued

Offset	Name	Bit Pos.									
0x28 ... 0x2F	Reserved										
0x30	CCBUF0	7:0	CCBUF[7:0]								
		15:8	CCBUF[15:8]								
		23:16									
		31:24									
0x34	CCBUF1	7:0	CCBUF[7:0]								
		15:8	CCBUF[15:8]								
		23:16									
		31:24									

### 53.8 Register Description

Registers can be 8, 16, or 32 bits wide. Atomic 8-, 16- and 32-bit accesses are supported. In addition, the 8-bit quarters and 16-bit halves of a 32-bit register, and the 8-bit halves of a 16-bit register can be accessed directly.

Some registers are optionally write-protected by the Peripheral Access Controller (PAC). Optional PAC write protection is denoted by the "PAC Write-Protection" property in each individual register description. For details, refer to [53.5.8 Register Access Protection](#).

Some registers are synchronized when read and/or written. Synchronization is denoted by the "Write-Synchronized" or the "Read-Synchronized" property in each individual register description. For details, refer to [53.6.7 Synchronization](#).



### 53.8.1 Control A

**Name:** CTRLA  
**Offset:** 0x00  
**Reset:** 0x00000000  
**Property:** PAC Write-Protection, Enable-Protected

	Bit	31	30	29	28	27	26	25	24
		MAXCMP[3:0]					ANGULAR[2:0]		
Access		RW	RW	RW	RW		RW	RW	RW
Reset		0	0	0	0		0	0	0
	Bit	23	22	21	20	19	18	17	16
			PINVEN2	PINVEN1	PINVEN0		PINEN2	PINEN1	PINEN0
Access			RW	RW	RW		RW	RW	RW
Reset			0	0	0		0	0	0
	Bit	15	14	13	12	11	10	9	8
		PEREN	SWAP			ALOCK	CONF[2:0]		
Access		RW	RW			RW	RW	RW	RW
Reset		0	0			0	0	0	0
	Bit	7	6	5	4	3	2	1	0
			RUNSTDBY			MODE[1:0]		ENABLE	SWRST
Access			RW			RW	RW	RW	W
Reset			0			0	0	0	0

**Bits 31:28 – MAXCMP[3:0]** Maximum Consecutive Missing Pulses

These bits define the threshold for the maximum consecutive missing pulses in AUTOC configuration of the QDEC mode.

Outside of AUTOC configuration of QDEC mode, these bits have no effect.

These bits are not synchronized.

**Bits 26:24 – ANGULAR[2:0]** Angular Counter Length

In QDEC mode, these bits define the size of the Angular counter within COUNT. Angular counter size is equal to CTRLA.ANGULAR+9. The remaining MSB of the COUNTER register are used for counting revolutions.

For example, CTRLA.ANGULAR=0 defines the 9 LSB of COUNT as Angular counter and the residual 7 MSB of COUNT as Revolution counter. CTRLA.ANGULAR=7 will define a 16-bit Angular counter and no Revolution counter.

Outside of QDEC mode, these bits have no effect.

These bits are not synchronized.

**Table 53-1. Angular and Revolution Counters in COUNTER Register**

ANGULAR[2:0]	Angular counter	Revolution counter
0x0	COUNTER[0:8]	COUNTER[9:15]
0x1	COUNTER[0:9]	COUNTER[10:15]

.....continued		
ANGULAR[2:0]	Angular counter	Revolution counter
0x2	COUNTER[0:10]	COUNTER[11:15]
0x3	COUNTER[0:11]	COUNTER[12:15]
0x4	COUNTER[0:12]	COUNTER[13:15]
0x5	COUNTER[0:13]	COUNTER[14:15]
0x6	COUNTER[0:14]	COUNTER[15]
0x7	COUNTER[0:15]	no revolution counter

**Bits 20, 21, 22 – PINVEN** IO Pin x Invert Enable

When this bit is written to '1', the corresponding input pin active level is inverted. This bit has no effect if PINENx bit is zero.

In COUNTER mode only PINVEN[0] is significant.

This bit is not synchronized.

Value	Description
0	Pin active level is not inverted.
1	Pin active level is inverted.

**Bits 16, 17, 18 – PINEN** PDEC Input From Pin x Enable

This bit enables the IO pin x as signal input.

In COUNTER mode, only PINVEN[0] is significant.

This bit is not synchronized.

Value	Description
0	Event line is the signal input.
1	I/O pin is the signal input.

**Bit 15 – PEREN** Period Enable

This bit is used to enable the CC0 register as counter period.

This bit is not synchronized.

Value	Description
0	Period register function is disabled.
1	CC0 is acting as counter period register.

**Bit 14 – SWAP** PDEC Phase A and B Swap

This bit is used to swap input source of signal 0 and 1.

In COUNTER mode this bit has no effect.

This bit is not synchronized.

Value	Description
0	The input sources of signal 0 and 1 are not swapped.
1	The input sources of signal 0 and 1 are swapped.

**Bit 11 – ALOCK** Auto Lock

When this bit is set, the Lock Update bit in Control B register (CTRLB.LUPD) is set by hardware when an UPDATE condition is detected.

This bit is not synchronized.

Value	Description
0	Auto Lock is disabled.
1	Auto Lock is enabled.

### Bits 10:8 – CONF[2:0] PDEC Configuration

These bits define the PDEC configuration.

Outside of QDEC mode, these bits have no effect.

These bits are not synchronized.

Value	Name	Description
0	X4	Quadrature decoder direction
1	X4S	Secure Quadrature decoder direction
2	X2	Decoder direction
3	X2S	Secure decoder direction
4	AUTO	Auto correction mode

### Bit 6 – RUNSTDBY Run in Standby

This bit is used to keep the PDEC running in standby mode.

This bit is not synchronized.

Value	Description
0	The PDEC is halted in standby.
1	The PDEC continues to run in standby.

### Bits 3:2 – MODE[1:0] Operation Mode

These bits select one of the QDEC, HALL, COUNTER modes.

These bits are not synchronized.

Value	Name	Description
0x0	QDEC	QDEC operating mode
0x1	HALL	HALL operating mode
0x2	COUNTER	COUNTER operating mode

### Bit 1 – ENABLE Enable

Due to synchronization, there is delay between writing CTRLA.ENABLE until the peripheral is enabled/

disabled. The value written to CTRLA.ENABLE will read back immediately, and the Enable

Synchronization Busy bit in the Synchronization Busy register (SYNCBUSY.ENABLE) will be set.

SYNCBUSY.ENABLE will be cleared when the operation is complete.

Value	Description
0	The peripheral is disabled.
1	The peripheral is enabled.

### Bit 0 – SWRST Software Reset

Writing a '0' to this bit has no effect.

Writing a '1' to this bit resets all registers in the PDEC (except DBGCTRL) to their initial state, and the PDEC will be disabled.

Writing a '1' to CTRLA.SWRST will always take precedence; all other writes in the same write-operation will be discarded.

Due to synchronization, there is a delay from writing CTRLA.SWRST until the Reset is complete.

CTRLA.SWRST and SYNCBUSY.SWRST will both be cleared when the Reset is complete.

Value	Description
0	There is no Reset operation ongoing.

# SAM D5x/E5x Family Data Sheet

## PDEC – Position Decoder

---

---

Value	Description
1	A Reset operation is ongoing.

### 53.8.2 Control B Clear

**Name:** CTRLBCLR  
**Offset:** 0x04  
**Reset:** 0x00  
**Property:** PAC Write-Protection, Read-Synchronized, Write-Synchronized

This register allows the user to change this register without doing a read-modify-write operation. Changes in this register will also be reflected in the Control B Set (CTRLBSET) register.

	Bit	7	6	5	4	3	2	1	0
		CMD[2:0]						LUPD	
Access		RW	RW	RW				RW	
Reset		0	0	0				0	

#### Bits 7:5 – CMD[2:0] Command

These bits can be used for software control of the PDEC. When a command has been executed, the CMD bit group will read back zero. The commands are executed on the next prescaled GCLK\_PDEC clock cycle.

Writing a zero to this bit group has no effect.

Writing a valid value to these bits will clear the corresponding pending command.

Writing a '0' to these bits has no effect.

Writing a '1' to an individual bit will clear the corresponding bit.

Value	Name	Description
0	NONE	No action
1	RETRIGGER	Force a counter restart or re-trigger
2	UPDATE	Force update of double buffered registers
3	READSYNC	Force a read synchronization of COUNT
4	START	Start QDEC/HALL
5	STOP	Stop QDEC/HALL

#### Bit 1 – LUPD Lock Update

This bit controls the update operation of the PDEC buffered registers.

When CTRLB.LUPD is set, no any update of the registers with value of its buffered register is performed on hardware UPDATE condition. Locking the update ensures that all buffer registers are valid before an hardware update is performed. After all the buffer registers are loaded correctly, the buffered registers can be unlocked.

Writing a '0' to this bit has no effect.

Writing a '1' to this will disable the lock update.

Value	Description
0	The PRESCBUF, FILTERBUF and CCBUFx buffer registers value are copied into CCx and PER registers on hardware update condition.
1	The PRESCBUF, FILTERBUF and CCBUFx buffer registers value are not copied into CCx and PER registers on hardware update condition.

### 53.8.3 Control B Set

**Name:** CTRLBSET  
**Offset:** 0x05  
**Reset:** 0x00  
**Property:** PAC Write-Protection, Read-Synchronized, Write-Synchronized

This register allows the user to change this register without doing a read-modify-write operation. Changes in this register will also be reflected in the Control B Clear (CTRLBCLR) register.

Bit	7	6	5	4	3	2	1	0
	CMD[2:0]						LUPD	
Access	RW	RW	RW				RW	
Reset	0	0	0				0	

#### Bits 7:5 – CMD[2:0] Command

These bits can be used for software control of the PDEC. When a command has been executed, the CMD bit group will read back zero. The commands are executed on the next prescaled GCLK\_PDEC clock cycle.

Writing a zero to this bit group has no effect.

Writing a valid value to these bits will set the associated command.

Value	Name	Description
0	NONE	No action
1	RETRIGGER	Force a counter restart or retrigger
2	UPDATE	Force update of double buffered registers
3	READSYNC	Force a read synchronization of COUNT
4	START	Start QDEC/HALL
5	STOP	Stop QDEC/HALL

#### Bit 1 – LUPD Lock Update

This bit controls the update operation of the PDEC buffered registers.

When CTRLB.LUPD is set, no any update of the registers with value of its buffered register is performed on hardware UPDATE condition. Locking the update ensures that all buffer registers are valid before an hardware update is performed. After all the buffer registers are loaded correctly, the buffered registers can be unlocked.

Writing a '1' to this will enable the Lock Update.

Value	Description
0	The PRESCBUF, FILTERBUF and CCBUFx buffer registers value are copied into CCx and PER registers on hardware update condition.
1	The PRESCBUF, FILTERBUF and CCBUFx buffer registers value are not copied into CCx and PER registers on hardware update condition.

# SAM D5x/E5x Family Data Sheet

## PDEC – Position Decoder

### 53.8.4 Event Control

**Name:** EVCTRL  
**Offset:** 0x06  
**Reset:** 0x0000  
**Property:** Enable-Protected, PAC Write-Protection

	15	14	13	12	11	10	9	8
			MCEO1	MCEO0	VLCEO	DIREO	ERREO	OVFEO
Access			RW	RW	RW	RW	RW	RW
Reset			0	0	0	0	0	0

	7	6	5	4	3	2	1	0
	EVEI[2:0]			EVINV[2:0]			EVACT[1:0]	
Access	RW	RW	RW	RW	RW	RW	RW	RW
Reset	0	0	0	0	0	0	0	0

#### Bits 12, 13 – MCEO Match Channel x Event Output Enable

These bits control whether event match on channel x is enabled or not and generated for every match.

Value	Description
0	Match event on channel x is disabled and will not be generated.
1	Match event on channel x is enabled and will be generated for every compare.

#### Bit 11 – VLCEO Velocity Output Event Enable

This bit is used to enable the velocity event. When enabled, an event level will be generated for each change on the qualified PDEC phases.

This bit has no effect when COUNTER operation mode is selected.

Value	Description
0	VLC output event is disabled and will not be generated.
1	VLC output is enabled and will be generated for every valid velocity condition.

#### Bit 10 – DIREO Direction Output Event Enable

This bit is used to enable the Direction event. When enabled, an event level output is generated to report the rotation direction.

Value	Description
0	DIR output event is disabled and will not be generated.
1	DIR output is enabled and changes the level when the rotation direction changes.

#### Bit 9 – ERREO Error Output Event Enable

This bit enables the output of the Error event (ERR).

Value	Description
0	ERR Event output is disabled.
1	ERR Event output is enabled.

#### Bit 8 – OVFEO Overflow/Underflow Output Event Enable

This bit is used to enable the Overflow/Underflow event. When enabled, an event will be generated when the Counter overflows/underflows.

Value	Description
0	Overflow/Underflow event is disabled and will not be generated.

Value	Description
1	Overflow/Underflow event is enabled and will be generated for every counter overflow/underflow.

**Bits 7:5 – EVEI[2:0]** Event Input Enable

This bit is used to enable asynchronous input event to the counter.

Value	Description
0	Incoming events are disabled.
1	Incoming events are enabled.

**Bits 4:2 – EVINV[2:0]** Inverted Event Input Enable

This bit inverts the asynchronous input event to the counter.

Value	Description
0	Input event source is not inverted.
1	Input event source is inverted.

**Bits 1:0 – EVACT[1:0]** Event Action

These bits have an effect only when COUNTER operation mode is selected, and ignored in all other operation modes.

These bits define the event action the counter will perform on an event.

Value	Name	Description
0	OFF	Event action disabled
1	RETRIGGER	Start, restart or retrigger on event
2	COUNT	Count on event



### 53.8.5 Interrupt Enable Clear

**Name:** INTENCLR  
**Offset:** 0x08  
**Reset:** 0x00  
**Property:** PAC Write-Protection

This register allows the user to change this register without doing a read-modify-write operation. Changes in this register will also be reflected in the Interrupt Enable Set (INTENSET) register.

	7	6	5	4	3	2	1	0
			MC1	MC0	VLC	DIR	ERR	OVF
Access			RW	RW	RW	RW	RW	RW
Reset			0	0	0	0	0	0

#### Bits 4, 5 – MC Channel x Compare Match Disable

Writing a '0' to MCx has no effect.

Writing a '1' to MCx will clear the corresponding Match Channel x Interrupt Disable/Enable bit, which disables the Match Channel x interrupt.

Value	Description
0	The Match Channel x interrupt is disabled.
1	The Match Channel x interrupt is enabled.

#### Bit 3 – VLC Velocity Interrupt Disable

Writing a '0' to this bit has no effect.

Writing a '1' to this bit will clear the Velocity Interrupt Disable/Enable bit, which disables the Velocity interrupt.

This bit has no effect when COUNTER operation mode is selected.

Value	Description
0	The Velocity interrupt is disabled.
1	The Velocity interrupt is enabled.

#### Bit 2 – DIR Direction Interrupt Disable

Writing a '0' to this bit has no effect.

Writing a '1' to this bit will clear the Direction Change Interrupt Disable/Enable bit, which disables the Direction Change interrupt.

This bit has no effect when COUNTER operation mode is selected.

Value	Description
0	The Direction Change interrupt is disabled.
1	The Direction Change interrupt is enabled.

#### Bit 1 – ERR Error Interrupt Disable

Writing a '0' to this bit has no effect.

Writing a '1' to this bit will clear the Error Interrupt Disable/Enable bit, which disables the Error interrupt.

Value	Description
0	The Error interrupt is disabled.
1	The Error interrupt is enabled.

#### Bit 0 – OVF Overflow/Underflow Interrupt Disable

Writing a '0' to this bit has no effect.

# SAM D5x/E5x Family Data Sheet

## PDEC – Position Decoder

Writing a '1' to this bit will clear the Overflow Interrupt Disable/Enable bit, which disables the Overflow interrupt.

Value	Description
0	The Overflow interrupt is disabled.
1	The Overflow interrupt is enabled.

### 53.8.6 Interrupt Enable Set

**Name:** INTENSET  
**Offset:** 0x09  
**Reset:** 0x00  
**Property:** PAC Write-Protection

This register allows the user to change this register without doing a read-modify-write operation. Changes in this register will also be reflected in the Interrupt Enable Clear (INTENCLR) register.

	7	6	5	4	3	2	1	0
Bit			MC1	MC0	VLC	DIR	ERR	OVF
Access			RW	RW	RW	RW	RW	RW
Reset			0	0	0	0	0	0

#### Bits 4, 5 – MC Channel x Compare Match Enable

Writing a '0' to MCx has no effect.

Writing a '1' to MCx will set the corresponding Match Channel x Interrupt Disable/Enable bit, which enables the Match Channel x interrupt.

Value	Description
0	The Match Channel x interrupt is disabled.
1	The Match Channel x interrupt is enabled.

#### Bit 3 – VLC Velocity Interrupt Enable

Writing a '0' to this bit has no effect.

Writing a '1' to this bit will set the Velocity Interrupt Disable/Enable bit, which enables the Velocity interrupt.

This bit has no effect when COUNTER operation mode is selected.

Value	Description
0	The Velocity interrupt is disabled.
1	The Velocity interrupt is enabled.

#### Bit 2 – DIR Direction Interrupt Enable

Writing a '0' to this bit has no effect.

Writing a '1' to this bit will set the Direction Change Interrupt Disable/Enable bit, which enables the Direction Change interrupt.

This bit has no effect when COUNTER operation mode is selected.

Value	Description
0	The Direction Change interrupt is disabled.
1	The Direction Change interrupt is enabled.

#### Bit 1 – ERR Error Interrupt Enable

Writing a '0' to this bit has no effect.

Writing a '1' to this bit will set the Error Interrupt Disable/Enable bit, which enables the Error interrupt.

Value	Description
0	The Error interrupt is disabled.
1	The Error interrupt is enabled.

#### Bit 0 – OVF Overflow/Underflow Interrupt Enable

Writing a '0' to this bit has no effect.

# SAM D5x/E5x Family Data Sheet

## PDEC – Position Decoder

Writing a '1' to this bit will set the Overflow Interrupt Disable/Enable bit, which enable the Overflow interrupt.

Value	Description
0	The Overflow interrupt is disabled.
1	The Overflow interrupt is enabled.

### 53.8.7 Interrupt Flag Status and Clear

**Name:** INTFLAG  
**Offset:** 0x0A  
**Reset:** 0x00  
**Property:** -

	7	6	5	4	3	2	1	0
			MC1	MC0	VLC	DIR	ERR	OVF
Access			RW	RW	RW	RW	RW	RW
Reset			0	0	0	0	0	0

#### Bits 4, 5 – MC Channel x Compare Match

This flag is set on the next CLK\_PDEC\_CNT cycle after a match with the compare condition, and will generate an interrupt request if the corresponding Match Channel x Interrupt Enable bit in the Interrupt Enable Set register (INTENSET.MCx) is '1'.

Writing a '0' to one of these bits has no effect.

Writing a '1' to one of these bits will clear the corresponding Match Channel x interrupt flag.

#### Bit 3 – VLC Velocity

This flag is set if a velocity transition occurs, and will generate an interrupt request if the Velocity Interrupt Enable bit in Interrupt Enable Set register (INTENSET.VLC) is '1'.

Writing a '0' to this bit has no effect.

Writing a '1' to this bit clears the Velocity transition interrupt flag.

This flag is never set when COUNTER operation mode is selected.

#### Bit 2 – DIR Direction Change

This flag is set if a direction change occurs, and will generate an interrupt request if the Direction Change Interrupt Enable bit in Interrupt Enable Set register (INTENSET.DIR) is '1'.

Writing a '0' to this bit has no effect.

Writing a '1' to this bit clears the Velocity transition interrupt flag.

This flag is never set when COUNTER operation mode is selected.

#### Bit 1 – ERR Error

This flag is set when an error condition is detected, and will generate an interrupt request if the Error Interrupt Enable bit in the Interrupt Enable Set register (INTENSET.ERR) is '1'. The error source can be identified by reading the Status (STATUS) register.

Writing a '0' to this bit has no effect.

Writing a '1' to this bit clears the Error interrupt flag.

#### Bit 0 – OVF Overflow/Underflow

This flag is set on the next CLK\_TC\_CNT cycle after an overflow condition occurs, and will generate an interrupt request if the Overflow Interrupt Enable bit in the Interrupt Enable Set register (INTENSET.OVF) is '1'.

Writing a '0' to this bit has no effect.

Writing a '1' to this bit clears the Overflow interrupt flag.

### 53.8.8 Status

**Name:** STATUS  
**Offset:** 0x0C  
**Reset:** 0x0040  
**Property:** Read-Synchronized, Write-Synchronized

	Bit	15	14	13	12	11	10	9	8
				CCBUFV1	CCBUFV0			FILTERBUFV	PRESCBUFV
Access				R	R			R	R
Reset				0	0			0	0
	Bit	7	6	5	4	3	2	1	0
		DIR	STOP	HERR	WINERR		MPERR	IDXERR	QERR
Access		R	R	RW	RW		RW	RW	RW
Reset		0	1	0	0		0	0	0

**Bits 12, 13 – CCBUFV** Compare Channel x Buffer Valid

The bit is set when a new value is written to the corresponding CCBUF register.  
 The bit is cleared by writing a '1' to the corresponding location or automatically cleared on an UPDATE condition.

**Bit 9 – FILTERBUFV** Filter Buffer Valid

This bit is set when a new value is written to the PRESCALERBUF register.  
 The bit is cleared by writing a '1' to the corresponding location or automatically cleared on an UPDATE condition.  
 This bit is always read '0' when COUNTER operation mode is selected.

**Bit 8 – PRESCBUFV** Prescaler Buffer Valid

This bit is set when a new value is written to the PRESC register.  
 The bit is cleared by writing a '1' to the corresponding location or automatically cleared on an UPDATE condition.

**Bit 7 – DIR** Direction Status Flag

This bit reflects the HALL/QDEC direction.  
 In COUNTER mode, this bit is always read '0'.

Value	Description
0	Clockwise direction.
1	Counter-clockwise direction.

**Bit 6 – STOP** Stop

This bit reflects the HALL/QDEC decoding status.  
 In COUNTER mode, this bit is always read '0'.

Value	Description
0	PDEC/HALL decoding is running.
1	PDEC/HALL decoding is stopped.

**Bit 5 – HERR** Hall Error Flag

This flag is set when an invalid HALL code is detected.

The flag is cleared by writing a '1' to this bit location.  
Outside of HALL mode, this bits is always read '0'.

**Bit 4 – WINERR** Window Error Flag

This flag is set when the counter is outside the window monitor.  
The flag is cleared by writing a '1' to this bit location.  
Outside of HALL mode, this bits is always read '0'.

**Bit 2 – MPERR** Missing Pulse Error flag

This flag is set when a missing pulse error condition is detected.  
The flag is cleared by writing a '1' to this bit location.  
Outside of QDEC mode, this bits is always read '0'.

**Bit 1 – IDXERR** Index Error Flag

This flag is set when an index error condition is detected.  
The flag is cleared by writing a '1' to this bit location.  
Outside of QDEC mode, this bits is always read '0'.

**Bit 0 – QERR** Quadrature Error Flag

This flag is set when an invalid QDEC transition is detected.  
The flag is cleared by writing a '1' to this bit location.  
Outside of QDEC mode, this bits is always read '0'.

### 53.8.9 Debug Control

**Name:** DBGCTRL  
**Offset:** 0x0F  
**Reset:** 0x00  
**Property:** PAC Write-Protection

	7		6		5		4		3		2		1		0
	DBGRUN														
Access															RW
Reset															0

#### Bit 0 – DBGRUN Debug Run Mode

This bit is not affected by software reset and should not be changed by software while the PDEC module is enabled.

Value	Description
0	The PDEC module is halted when the device is halted in debug mode.
1	The PDEC module continues normal operation when the device is halted in debug mode.



### 53.8.10 Synchronization Status

**Name:** SYNCBUSY  
**Offset:** 0x10  
**Reset:** 0x00000000  
**Property:** Read-Only

	Bit	31	30	29	28	27	26	25	24
Access									
Reset									
	Bit	23	22	21	20	19	18	17	16
Access									
Reset									
	Bit	15	14	13	12	11	10	9	8
									CC1
Access									R
Reset									0
	Bit	7	6	5	4	3	2	1	0
		CC0	COUNT	FILTER	PRESC	STATUS	CTRLB	ENABLE	SWRST
Access		R	R	R	R	R	R	R	R
Reset		0	0	0	0	0	0	0	0

**Bits 7, 8 – CC** Compare Channel x Synchronization Busy

This bit is cleared when the synchronization of Compare Channel x (CCx) register between the clock domains is complete.

This bit is set when the synchronization of Compare Channel x (CCx) register between clock domains is started.

**Bit 6 – COUNT** Count Synchronization Busy

This bit is cleared when the synchronization of Count register between the clock domains is complete.

This bit is set when the synchronization of Count register between clock domains is started.

**Bit 5 – FILTER** Filter Synchronization Busy

This bit is cleared when the synchronization of Filter register between the clock domains is complete.

This bit is set when the synchronization of Filter register between clock domains is started.

This bit is always read '0' when COUNTER operation mode is selected.

**Bit 4 – PRESC** Prescaler Synchronization Busy

This bit is cleared when the synchronization of Prescaler register between the clock domains is complete.

This bit is set when the synchronization of Prescaler register between clock domains is started.

**Bit 3 – STATUS** Status Synchronization Busy

This bit is cleared when the synchronization of Status register between the clock domains is complete.

This bit is set when the synchronization of Status register between clock domains is started.

**Bit 2 – CTRLB** Control B Synchronization Busy

This bit is cleared when the synchronization of Control B register between the clock domains is complete.

This bit is set when the synchronization of Control B register between clock domains is started.

**Bit 1 – ENABLE** Enable Synchronization Busy

This bit is cleared when the synchronization of Enable register bit between the clock domains is complete.

This bit is set when the synchronization of Enable register bit between clock domains is started.

**Bit 0 – SWRST** Software Reset Synchronization Busy

This bit is cleared when the synchronization of Software Reset register bit between the clock domains is complete.

This bit is set when the synchronization of Software Reset register bit between clock domains is started.

### 53.8.11 Prescaler Value

**Name:** PRESC  
**Offset:** 0x14  
**Reset:** 0x00  
**Property:** Write-Synchronized

	7	6	5	4	3	2	1	0
	PRESC[3:0]							
Access					RW	RW	RW	RW
Reset					0	0	0	0

#### Bits 3:0 – PRESC[3:0] Prescaler Value

These bits select the GCLK prescaler factor.

Value	Name	Description
0	DIV1	No division
1	DIV2	Divide by 2
2	DIV4	Divide by 4
3	DIV8	Divide by 8
4	DIV16	Divide by 16
5	DIV32	Divide by 32
6	DIV64	Divide by 64
7	DIV128	Divide by 128
8	DIV256	Divide by 256
9	DIV512	Divide by 512
10	DIV1024	Divide by 1024

### 53.8.12 Filter Value

**Name:** FILTER  
**Offset:** 0x15  
**Reset:** 0x00  
**Property:** Write-Synchronized

Bit	7	6	5	4	3	2	1	0
	FILTER[7:0]							
Access	RW	RW	RW	RW	RW	RW	RW	RW
Reset	0	0	0	0	0	0	0	0

**Bits 7:0 – FILTER[7:0]** Filter Value

These bits select the PDEC inputs filter length.

These bits have no effect when COUNTER operation mode is selected.

### 53.8.13 Prescaler Buffer Value

**Name:** PRESCBUF  
**Offset:** 0x18  
**Reset:** 0x00  
**Property:** Write-Synchronized

	7	6	5	4	3	2	1	0
	PRESCBUF[3:0]							
Access					RW	RW	RW	RW
Reset					0	0	0	0

#### Bits 3:0 – PRESCBUF[3:0] Prescaler Buffer Value

These bits hold the value of the prescaler buffer register. The value is copied in the corresponding PRESC register on UPDATE condition.

Value	Name	Description
0	DIV1	No division
1	DIV2	Divide by 2
2	DIV4	Divide by 4
3	DIV8	Divide by 8
4	DIV16	Divide by 16
5	DIV32	Divide by 32
6	DIV64	Divide by 64
7	DIV128	Divide by 128
8	DIV256	Divide by 256
9	DIV512	Divide by 512
10	DIV1024	Divide by 1024

### 53.8.14 Filter Buffer Value

**Name:** FILTERBUF  
**Offset:** 0x19  
**Reset:** 0x00  
**Property:** Write-Synchronized

Bit	7	6	5	4	3	2	1	0
	FILTERBUF[7:0]							
Access	RW	RW	RW	RW	RW	RW	RW	RW
Reset	0	0	0	0	0	0	0	0

**Bits 7:0 – FILTERBUF[7:0]** Filter Buffer Value

These bits hold the value of the filter buffer register. The value is copied in the corresponding FILTER register on UPDATE condition.

These bits have no effect when COUNTER operation mode is selected.

### 53.8.15 Counter Value

**Name:** COUNT  
**Offset:** 0x1C  
**Reset:** 0x00000000  
**Property:** PAC Write-Protection, Read-Synchronized, Write-Synchronized

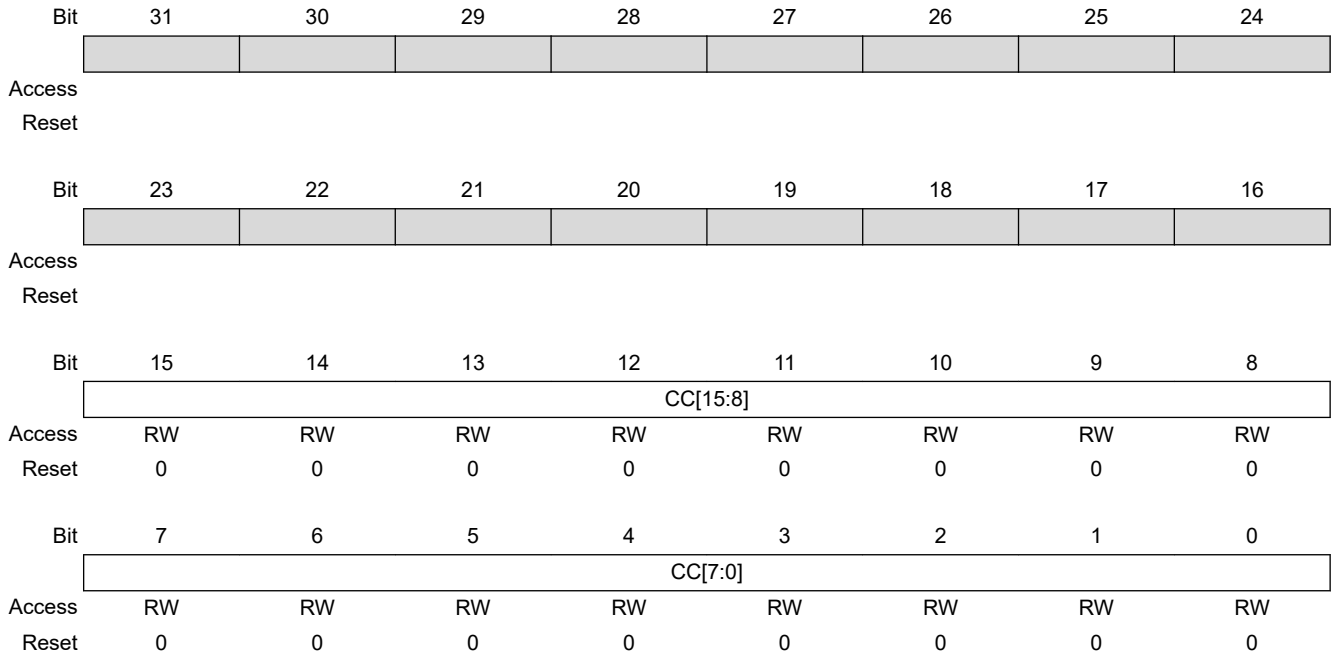
Bit	31	30	29	28	27	26	25	24
Access								
Reset								
Bit	23	22	21	20	19	18	17	16
Access								
Reset								
Bit	15	14	13	12	11	10	9	8
	COUNT[15:8]							
Access	RW	RW	RW	RW	RW	RW	RW	RW
Reset	0	0	0	0	0	0	0	0
Bit	7	6	5	4	3	2	1	0
	COUNT[7:0]							
Access	RW	RW	RW	RW	RW	RW	RW	RW
Reset	0	0	0	0	0	0	0	0

**Bits 15:0 – COUNT[15:0]** Counter Value

These bits contain the counter value. To read the most updated counter value, the READSYNC software command must be applied first (CTRLBSET.CMD = READSYNC).

### 53.8.16 Channel x Compare Value

**Name:** CCx  
**Offset:** 0x20 + x\*0x04 [x=0..1]  
**Reset:** 0x00000000  
**Property:** Read-Synchronized, Write-Synchronized

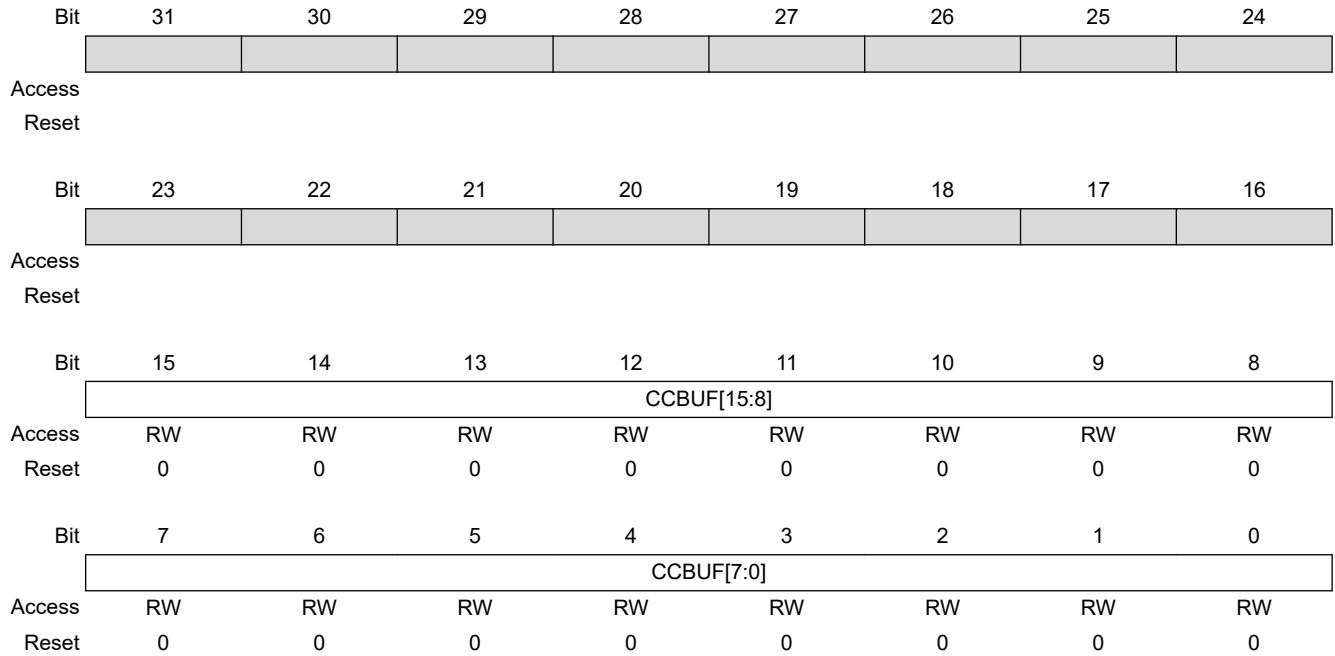


**Bits 15:0 – CC[15:0]** Channel Compare Value  
 These bits hold value of the channel x compare register.



### 53.8.17 Channel x Compare Buffer Value

**Name:** CCBUFx  
**Offset:** 0x30 + x\*0x04 [x=0..1]  
**Reset:** 0x00000000  
**Property:** Write-Synchronized



**Bits 15:0 – CCBUF[15:0] Channel Compare Buffer Value**

These bits hold the value of the channel x compare buffer register. The register is used as buffer for the associated compare register (CCx). Accessing this register using the CPU will affect the corresponding CCBVx status bit (STATUS.CCBUFVx).

### 54. Electrical Characteristics at 85°C

#### 54.1 Disclaimer

All typical values are measured at T = 25°C unless otherwise specified. All minimum and maximum values are valid across operating temperature and voltage unless otherwise specified.

#### 54.2 Absolute Maximum Ratings

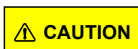
Stresses beyond those listed in the table below may cause permanent damage to the device. This is a stress rating only and functional operation of the device at these or other conditions beyond those indicated in the operational sections of this specification is not implied. Exposure to absolute maximum rating conditions for extended periods may affect device reliability.

**Table 54-1. Absolute Maximum Ratings**

Symbol	Description	Min.	Max.	Units
V <sub>DD</sub>	Power supply voltage	0	3.8	V
I <sub>VDD</sub>	Current into a V <sub>DD</sub> pin <sup>(1,2)</sup>	-	60	mA
I <sub>GND</sub>	Current out of a GND pin	-	45	mA
V <sub>PIN</sub>	Pin voltage with respect to GND and V <sub>DD</sub>	GND-0.6V	VDD+0.6V	V
T <sub>storage</sub>	Storage temperature	-60	150	°C

**Note:**

- For 100-pin packages: I<sub>VDD</sub> (pin 92) = 360 mA and I<sub>VDD</sub> (pin 77) = 210 mA.
- For 128-pin packages: I<sub>VDD</sub> (pin 118) = 360 mA and I<sub>VDD</sub> (pin 97) = 210 mA.



This device is sensitive to electrostatic discharges (ESD). Improper handling may lead to permanent performance degradation or malfunctioning. Handle the device following best practice ESD protection rules: Be aware that the human body can accumulate charges large enough to impair functionality or destroy the device.

#### 54.3 General Operating Ratings

The device must operate within the ratings listed below in order for all other electrical characteristics and typical characteristics of the device to be valid.

**Table 54-2. General Operating Conditions**

Symbol	Description	Min.	Typ.	Max.	Units
V <sub>DDIO</sub>	IO Supply Voltage	1.71 <sup>(1)</sup>	3.3	3.63	V
V <sub>DDIOB</sub>	IOB Supply Voltage	1.71 <sup>(1)</sup>	3.3	3.63	V
V <sub>DDANA</sub>	Analog supply voltage	1.71 <sup>(1)</sup>	3.3	3.63	V

# SAM D5x/E5x Family Data Sheet

## Electrical Characteristics at 85°C

.....continued

Symbol	Description	Min.	Typ.	Max.	Units
T <sub>A</sub>	Temperature range	-40	25	85	°C
T <sub>J</sub>	Junction temperature	-	-	105	°C
V <sub>BAT</sub>	Battery Supply Voltage	1.71 <sup>(1)</sup>	3.3	3.63	V

**Note:**

1. With BOD33 disabled.
2. The same voltage must be applied to V<sub>DDIO</sub> and V<sub>DDANA</sub>. V<sub>DDIOB</sub> should be lower or equal to V<sub>DDIO</sub> / V<sub>DDANA</sub>. The common voltage is referred to as V<sub>DD</sub> in the data sheet.
3. When I/O pads in the V<sub>DDIOB</sub> cluster are multiplexed as analog pads, V<sub>DDANA</sub> is used to power the I/O. Using this configuration may result in an electrical conflict if the V<sub>DDIOB</sub> voltage is different from that of V<sub>DDIO</sub> / V<sub>DDANA</sub>. If the application has such requirements, it is required to power V<sub>DDIOB</sub>, V<sub>DDIO</sub> and V<sub>DDANA</sub> from the same supply source to ensure that they are always at the same voltage.

### 54.4 Injection Current

Stresses beyond those listed in the table below may cause permanent damage to the device. This is a stress rating only and functional operation of the device at these or other conditions beyond those indicated in the operational sections of this specification is not implied. Exposure to absolute maximum rating conditions for extended periods may affect device reliability.

**Table 54-3. Injection Current<sup>(1, 2)</sup>**

Symbol	Description	min	Typ.	max	Unit	Comments
I <sub>ICL</sub>	Input Low Injection Current	-15	-	-	mA	Note: 1, 4, 5 This Parameter applies to all pins.
I <sub>ICH</sub>	Input High Injection Current	-	-	15	mA	Note: 2, 3, 4, 5 This parameter applies to all pins, with the exception of 5V tolerant pins.
∑I <sub>ICT</sub>	Total Input Injection Current (Sum of all I/O and control pins) Absolute value of  ∑I <sub>ICT</sub>	-	-	45	mA	Absolute instantaneous sum of all ± input injection currents from all I/O pins.  $( I_{ICL}  +  I_{ICH} ) \leq \sum I_{ICT}$

# SAM D5x/E5x Family Data Sheet

## Electrical Characteristics at 85°C

### Note:

1. VIL source < (VSS - 0.6). Characterized but not tested.
2. VIH source > (VDDIO + 0.6) for non-5V tolerant pins only.
3. Digital 5V tolerant pins do not have an internal high side diode to VDDIO, and therefore, cannot tolerate any “positive” input injection current.
4. Injection currents > | 0 | can affect the ADC results by approximately 4 to 6 counts (i.e., VIH Source > (VDDIO + 0.6) or VIL source < (GND - 0.6)).
5. Any number and/or combination of I/O pins not excluded under IICL or IICH conditions are permitted provided the “absolute instantaneous” sum of the input injection currents from all pins do not exceed the specified  $\sum I_{ICT}$  limit. To limit the injection current the user must insert a resistor in series RS between input source voltage and device pin. The resistor value is calculated according to:
  - For negative Input voltages less than (GND-0.6):  $RS \geq (((GND - 0.6) - VIL \text{ source}) / IICL)$
  - For positive input voltages greater than (VDDIO+0.6):  $RS \geq ((VIH \text{ source} - VDDIO) / IICH)$
  - For Vpin voltages > VDD and < GND then RS = the larger of the values calculated above

## 54.5 Supply Characteristics

**Table 54-4. Supply Characteristics**

Symbol	Conditions	Voltage		
		Min.	Max.	Units
V <sub>DDIO</sub>	Full Voltage Range	1.71	3.63	V
V <sub>DDIOB</sub>				
V <sub>DDANA</sub>				
V <sub>BAT</sub>				

**Table 54-5. Supply Rates<sup>(1)</sup>**

Symbol	Conditions	Fall Rate	Rise Rate		Units
		Max.	Min.	Max.	
V <sub>DDIO</sub>	DC Supply Peripheral I/Os, Internal Regulator, and Analog Supply Voltage	50	0.2	100	mV/μs
V <sub>DDIOB</sub>					
V <sub>DDANA</sub>					
V <sub>BAT</sub>					

**Note:** 1. These values are based on simulation. They are not covered by production test limits or characterization.

# SAM D5x/E5x Family Data Sheet

## Electrical Characteristics at 85°C

**Table 54-6. Power Supply Current Requirement**

Symbol	Conditions	Current	Units
		Max	
$I_{input}$	Power-up Maximum Current	7	mA

**Note:**  $I_{input}$  is the minimum requirement for the power supply connected to the device.

## 54.6 Maximum Clock Frequencies

**Table 54-7. Maximum GCLK Generator Output Frequencies (see Notes 1, 2)**

Symbol	Description	Conditions	Fmax	Units
$f_{GCLKGEN0}$ / $f_{GCLK\_MAIN}$ (see <b>Note 2</b> )	GCLK Generator Output Frequency	undivided	200	MHz
$F_{gclkgenX}$ , $x=\{1;7\}$			200	MHz
$F_{gclkgenX}$ , $x=\{8;11\}$			100	MHz

**Note:**

1. These values are based on simulation. They are not covered by production test limits or characterization.
2. GCLK Generator 0 output frequency must not exceed the AHB clock frequency. The output must be divided in case of the GCLK Generator 0 input frequency is higher than the AHB clock frequency.

**Table 54-8. Maximum Peripheral Clock Frequencies<sup>(1)</sup>**

Symbol	Description	Max.	Units
$f_{CPU}$	CPU clock frequency	120	MHz
$f_{AHB}$	AHB clock frequency	120	MHz
$f_{APBX}$ , $x = \{A, B, C, D\}$	APBA, APBB, APBC and APBD clock frequency	120	MHz
$f_{GCLK\_DPLLx}$ , $x = \{0,1\}$	FDPLL0 and FDPLL1 Reference clock frequency	3.2	MHz
$f_{GCLK\_DPLLx\_32K}$ , $x = \{0,1\}$	FDPLL0 and FDPLL1 32k Reference clock frequency	100	kHz
$f_{GCLK\_DFLL48M\_REF}$	DFLL48M Reference clock frequency	33	kHz
$f_{GCLK\_EIC}$	EIC input clock frequency	100	MHz
$f_{GCLK\_FREQM\_MSR}$	FREQM Measure	200	MHz
$f_{GCLK\_FREQM\_REF}$	FREQM Reference	100	MHz
$f_{GCLK\_EVSYS\_CHANNEL\_x}$ , $x = \{0, \dots, 11\}$	EVSYS channel x input clock frequency	100	MHz
$f_{GCLK\_SERCOMx\_SLOW}$ , $x = \{0, \dots, 7\}$	Common SERCOMx slow input clock frequency	12	MHz
$f_{GCLK\_SERCOMx\_CORE}$ , $x = \{0, \dots, 7\}$	SERCOMx input clock frequency	100	MHz

# SAM D5x/E5x Family Data Sheet

## Electrical Characteristics at 85°C

.....continued

Symbol	Description	Max.	Units
$f_{\text{GCLK\_CANx}}$ , $x = \{0, 1\}$	CANx input clock frequency	100	MHz
$f_{\text{GCLK\_USB}}$	USB input clock frequency	60	MHz
$f_{\text{GCLK\_I2S}}$	I2S input clock frequency	100	MHz
$f_{\text{GCLK\_SDHCx\_SLOW}}$ , $x = \{0, 1\}$	Common SDHCx slow input clock frequency	12	MHz
$f_{\text{GCLK\_SDHCx\_CORE}}$ , $x = \{0, 1\}$	SDHCx input clock frequency	150	MHz
$f_{\text{GCLK\_TCCx}}$ , $x = \{0, \dots, 4\}$	TCCx input clock frequency	200	MHz
$f_{\text{GCLK\_TCx}}$ , $x = \{0, \dots, 3\}$	TC0, TC1, TC2, TC3 input clock frequency	200	MHz
$f_{\text{GCLK\_TCx}}$ , $x = \{4, \dots, 7\}$	TC4, TC5, TC6, TC7 input clock frequency	100	MHz
$f_{\text{GCLK\_PDEC}}$	PDEC input clock frequency	200	MHz
$f_{\text{GCLK\_CCL}}$	CCL input clock frequency	100	MHz
$f_{\text{GCLK\_GCLKIN}}$	External GCLK input clock frequency	50	MHz
$f_{\text{GCLK\_CM4\_TRACE}}$	CM4 Trace input clock frequency	120	MHz
$f_{\text{GCLK\_AC}}$	AC digital input clock frequency	100	MHz
$f_{\text{GCLK\_ADCx}}$ , $x = \{0, 1\}$	ADCx input clock frequency	100	MHz
$f_{\text{GCLK\_DAC}}$	DAC input clock frequency	100	MHz

### Note:

1. These values are based on simulation. They are not covered by production test limits or characterization.

## 54.7 Power Consumption

The values in this section are measured values of power consumption under the following conditions, except where noted:

- **Operating Conditions**

- CPU is running on Flash with automatic wait state
- Low-power cache enabled.
- BOD33 is disabled
- I/Os are inactive input mode with input trigger disabled

- **Oscillators**

- XOSC0 (crystal oscillator) running with external 32 MHz crystal
- XOSC32K (32 kHz crystal oscillator) running with external 32 kHz crystal in LP mode
- FDPLL is using XOSC32K as reference
- DFLL is using XOSC32K as reference

# SAM D5x/E5x Family Data Sheet

Electrical Characteristics at 85°C

Table 54-9. Active Current Consumption - Active Mode

Mode	Conditions	Regulator	Clock	V <sub>DD</sub>	T <sub>A</sub>	Typ	Max.	Units
Active	COREMARK <sup>(1)</sup>	LDO	FDPLL 120 MHz	1.8V	Max. at 85°C Typ at 25°C	136	162	μA/MHz
				3.3V		137	164	
			DFLL 48 MHz	1.8V		136	199	
				3.3V		136	199	
			XOSC 32 MHz	1.8V		146	243	
				3.3V		149	245	
		BUCK	FDPLL 120 MHz	1.8V		103	127	
				3.3V		65	89	
			DFLL 48 MHz	1.8V		102	152	
				3.3V		63	115	
			XOSC 32 MHz	1.8V		110	205	
				3.3V		73	153	
Idle	N/A	LDO	FDPLL 120 MHz	1.8V	21	46		
				3.3V	23	48		
			DFLL 48 MHz	1.8V	21	84		
				3.3V	21	84		
			XOSC 32 MHz	1.8V	25	115		
				3.3V	27	117		
		BUCK	FDPLL 120 MHz	1.8V	16	35		
				3.3V	11	28		
			DFLL 48 MHz	1.8V	16	63		
				3.3V	10	46		
			XOSC 32 MHz	1.8V	21	90		
				3.3V	19	71		

**Note:** System Configuration used:

- MCLK all APB clocks masked except MCLK and NVMCTRL
- MCLK.AHBMASK = 0x00C00FFF
- CMCC enabled

# SAM D5x/E5x Family Data Sheet

## Electrical Characteristics at 85°C

**Table 54-10. Standby Mode Current Consumption**

Mode	Conditions	Regulator Mode	V <sub>DD</sub> <sup>(1)</sup>	T <sub>A</sub>	Typ.	Max.	Units
Standby	Fast wake-up disabled (PM.STDBYCFG.FASTWKUP = 0x0), no peripheral running No System RAM retained (PM.STDBYCFG.RAMCFG = 0x2). 8 KB backup RAM retained	LDO	1.8V	Max at 85°C Typ at 25°C	43	870	μA
			3.3V		43	869	
		BUCK	1.8V		26	570	
			3.3V		17	440	
	Fast wake-up enabled (PM.STDBYCFG.FASTWKUP = 0x3), no peripheral running No System RAM retained (PM.STDBYCFG.RAMCFG = 0x2). 8 KB backup RAM retained	LDO	1.8V		85	1388	
			3.3V		85	1392	
		BUCK	1.8V		65	1047	
			3.3V		47	738	
	Fast wake-up disabled (PM.STDBYCFG.FASTWKUP = 0x0), RTC running on XOSC32K No System RAM retained (PM.STDBYCFG.RAMCFG = 0x2). 8 KB backup RAM retained	LDO	1.8V		43	870	
			3.3V		44	870	
		BUCK	1.8V		26	571	
			3.3V		18	443	
Fast wake-up disabled (PM.STDBYCFG.FASTWKUP = 0x0), RTC running on XOSC32K 32 KB System RAM retained (PM.STDBYCFG.RAMCFG = 0x1). 8 KB backup RAM retained	LDO	1.8V	45	912			
		3.3V	46	911			
	BUCK	1.8V	27	598			
		3.3V	19	462			
Standby	Fast wake-up disabled (PM.STDBYCFG.FASTWKUP = 0x0), RTC running on XOSC32K Full System RAM retained (PM.STDBYCFG.RAMCFG = 0x0). 8 KB backup RAM retained	LDO	1.8V	Max at 85°C Typ at 25°C	53	1068	μA
			3.3V		53	1067	
		BUCK	1.8V		32	702	
			3.3V		22	537	
	Fast wake-up enabled (PM.STDBYCFG.FASTWKUP=0x3), no peripheral running Full System RAM retained.	LDO	1.8V		101	1716	
			3.3 V		101	1722	
		BUCK	1.8V		78	1298	
			3.3V		55	911	
	Fast wake-up enabled (PM.STDBYCFG.FASTWKUP=0x3), RTC running on XOSC32K Full System RAM retained.	LDO	1.8V		102	1724	
			3.3V		103	1732	
		BUCK	1.8V		79	1305	
			3.3V		56	915	

**Note:**

- V<sub>DD</sub> is defined as the common voltage applied to V<sub>DDIO</sub> and V<sub>DDANA</sub>. Refer to [Acronyms and Abbreviations](#) for additional information on terminology.



# SAM D5x/E5x Family Data Sheet

Electrical Characteristics at 85°C

Table 54-11. Hibernate Mode Current Consumption

Mode	Conditions	Regulator Mode	V <sub>DD</sub> <sup>(1)</sup>	T <sub>A</sub>	Typ.	Max.	Units
Hibernate	No peripheral running No System RAM retained (PM.HIBCFG.RAMCFG = 0x2) No backup RAM retained (PM.HIBCFG.BRAMCFG = 0x2)	LDO	1.8V	Max. at 85°C Typ at 25°C	6	47	μA
			3.3V		6	48	
		BUCK	1.8V		3	29	
			3.3V		3	29	
	RTC is running on XOSC32K No System RAM retained (PM.HIBCFG.RAMCFG = 0x2) No backup RAM retained (PM.HIBCFG.BRAMCFG = 0x2)	LDO	1.8V		6	48	
			3.3V		7	49	
		BUCK	1.8V		3	30	
			3.3V		3	30	
	RTC is running on XOSC32K No System RAM retained (PM.HIBCFG.RAMCFG = 0x2) 4 KB backup RAM retained (PM.HIBCFG.BRAMCFG = 0x1)	LDO	1.8V		7	55	
			3.3V		8	56	
		BUCK	1.8V		3	35	
			3.3V		4	33	
	RTC is running on XOSC32K No System RAM retained (PM.HIBCFG.RAMCFG = 0x2) 8 KB backup RAM retained (PM.HIBCFG.BRAMCFG = 0x0)	LDO	1.8V		7	61	
			3.3V		8	63	
		BUCK	1.8V		4	39	
			3.3V		4	31	
	RTC is running on XOSC32K 32 KB System RAM retained (PM.HIBCFG.RAMCFG = 0x1) 8 KB backup RAM retained (PM.HIBCFG.BRAMCFG = 0x0)	LDO	1.8V		9	100	
			3.3V		10	101	
		BUCK	1.8V		5	65	
			3.3V		4	48	
	RTC is running on XOSC32K Full System RAM retained (PM.HIBCFG.RAMCFG = 0x0) 8 KB backup RAM retained (PM.HIBCFG.BRAMCFG = 0x0)	LDO	1.8V		16	255	
			3.3V		17	255	
		BUCK	1.8V		9	166	
			3.3V		7	121	

**Note:**

- V<sub>DD</sub> is defined as the common voltage applied to V<sub>DDIO</sub> and V<sub>DDANA</sub>. Refer to [Acronyms and Abbreviations](#) for additional information on terminology.

# SAM D5x/E5x Family Data Sheet

## Electrical Characteristics at 85°C

**Table 54-12. Backup and Off Mode Current Consumption**

Mode	Conditions	V <sub>DD</sub> <sup>(1)</sup>	T <sub>A</sub>	Typ.	Max.	Units			
Backup	Powered by VDDIO, no RTC running VDDIO+VDDANA consumption No backup RAM retained (PM.BKUPCFG.BRAMCFG = 0x2)	1.8V	Max. at 85°C Typ at 25°C	2.1	41.7	μA			
		3.3V		2.5	42.5				
	Powered by VDDIO with RTC running on XOSC32K VDDIO +VDDANA consumption No backup RAM retained (PM.BKUPCFG.BRAMCFG = 0x2)	1.8V		2.7	42.6				
		3.3V		3.3	43.6				
	Powered by VDDIO, no RTC running VDDIO+VDDANA consumption 4 KB backup RAM retained (PM.BKUPCFG.BRAMCFG = 0x1)	1.8V		2.4	48.4				
		3.3V		2.8	49.1				
	Powered by VDDIO, no RTC running VDDIO+VDDANA consumption 8 KB backup RAM retained (PM.BKUPCFG.BRAMCFG = 0x0)	1.8V		2.7	55.1				
		3.3V		3.1	55.8				
	Battery backup mode powered by VBAT with RTC running on XOSC32K	1.8V		2.7	42.6				
		3.3V		3.3	43.6				
	OFF	-		1.8V	Max at 85°C Typ at 25°C		0.191	2.30	μA
				3.3V			0.331	3.35	

**Note:**

- V<sub>DD</sub> is defined as the common voltage applied to V<sub>DDIO</sub> and V<sub>DDANA</sub>. Refer to [Acronyms and Abbreviations](#) for additional information on terminology.

### 54.8 Wake-Up Time

Conditions:

- V<sub>DD</sub> = 3.3V
- LDO Regulation mode (default mode)
- CPU clock = DFLL48 in open loop (default configuration)
- NVM automatic wait state and cache enabled (default configuration)

**Measurement Methods**

For IDLE and STANDBY, the exit of mode is done through asynchronous EIC wake-up. The wake-up time is measured between the toggle of the EIC pin and the set of the IO pin done by the first executed instructions in EIC interrupt handler.

For Backup and hibernate, the exit of mode is done through RTC wake-up. The wake-up time is measured between the toggle of the RTC pin (SUPC\_BKOUT\_RTCTGL) and the set of the IO done by the first executed instructions after reset.

For OFF mode, the exit of mode is done through Reset pin, the time is measured between the rising edge of the RESETN signal and the set of the IO done by the first executed instructions after Reset.

# SAM D5x/E5x Family Data Sheet

Electrical Characteristics at 85°C

**Table 54-13. Wake-Up Timing**

Sleep Mode	Conditions	Typ	Unit
IDLE		230	ns
STANDBY	STDBYCFG.FASTWKUP = 0	110	μs
	STDBYCFG.FASTWKUP = 1 Fast Wakeup is enabled on NVM.	92	μs
	STDBYCFG.FASTWKUP = 2 Fast Wakeup is enabled on the main voltage regulator.	25	μs
	STDBYCFG.FASTWKUP = 3 Fast Wakeup is enabled on both NVM and MAINVREG.	5	μs
Hibernate		320	μs
BACKUP		350	μs
OFF		210	μs

## 54.9 I/O Pin Characteristics

The pins have two different speeds controlled by the Drive Strength bit located in the Pin Configuration register PORT (PORT.PINCFG.DRVSTR).

**Table 54-14. I/O Pins Common Characteristics**

Symbol	Parameter	Conditions	Min.	Typ.	Max.	Units
V <sub>IL</sub>	Input Low-Level Voltage	V <sub>DD</sub> = 1.71V-3.6V	-	-	0.3 × V <sub>DD</sub>	V
V <sub>IH</sub>	Input High-Level Voltage	V <sub>DD</sub> = 1.71V-3.6V	0.7 × V <sub>DD</sub>	-	-	
V <sub>OL</sub>	Output Low-Level Voltage	V <sub>DD</sub> > 1.71V, I <sub>OL</sub> max	-	0.1 × V <sub>DD</sub>	0.2 × V <sub>DD</sub>	
V <sub>OH</sub>	Output High-Level Voltage	V <sub>DD</sub> > 1.71V, I <sub>OH</sub> max	0.8 × V <sub>DD</sub>	0.9 × V <sub>DD</sub>	-	
R <sub>PULL</sub>	Pull-up - Pull-down Resistance	-	20	40	60	kΩ
	Pull-down resistance on pads PA24 and PA25	-	14	23	28	
I <sub>LEAK</sub>	Input Leakage Current	Pull-up resistors disabled	-1	±0.015	1	μA

**Table 54-15. I/O Pins Maximum Output Current<sup>(2,3)</sup>**

Symbol	Parameter	Conditions	Backup Pins in Backup Mode	Backup and Normal Pins	Backup and Normal Pins	Units
				DRVSTR=0	DRVSTR=1	
I <sub>OL</sub>	Maximum Output low-level current	V <sub>DD</sub> =1.71V-3V	0.005	0.5	3	mA
		V <sub>DD</sub> =3V-3.63V	0.01	2	8	
I <sub>OH</sub>	Maximum Output high-level current	V <sub>DD</sub> =1.71V-3V	0.005	0.5	3	
		V <sub>DD</sub> =3V-3.63V	0.01	2	8	

# SAM D5x/E5x Family Data Sheet

## Electrical Characteristics at 85°C

**Table 54-16. I/O Pins Dynamic Characteristics (see Notes 1, 2, and 3)**

Symbol	Parameter	Conditions	Backup Pins in Backup Mode	Backup and Normal Pins	Backup and Normal Pins	Units
				DRVSTR=0	DRVSTR=1	
t <sub>RISE</sub>	Maximum Rise Time	C <sub>LOAD</sub> = 30 pF	4	0.04	0.01	μs
t <sub>FALL</sub>	Maximum Fall Time	C <sub>LOAD</sub> = 30 pF	4	0.04	0.01	

The pins with I<sup>2</sup>C alternative mode available are compliant with I<sup>2</sup>C specification.

All I<sup>2</sup>C pins support Standard mode (Sm), Fast mode (Fm), Fast plus mode (Fm+), and High speed mode (Hs). The available I<sup>2</sup>C pins are listed in the I/O Multiplexing section. When an I/O pin multiplexing value is set to an I<sup>2</sup>C function, internal pull-up/pull-down resistors are disabled.

**Note:**

1. These values are based on simulation. They are not covered by production test limits or characterization.
2. The pins **PA08, PA09, PA12, PA13, PA16, PA17, PA22, PA23, PD08, PD09** have faster fall-time in I2C Fast Plus mode (Fm+) and High Speed mode (HS). The fall-time can be in 1 ns range in Fm+ mode and in 5 ns range in HS mode.
3. The following pins are **Backup** pins and have different properties than normal pins: **PA00, PA01, PB00, PB01, PB02, PB03, PC00, PC01**.
4. USB pads **PA24, PA25** are compliant to the USB standard in USB mode.

## 54.10 Analog Characteristics

### 54.10.1 Voltage Regulator Characteristics

#### 54.10.1.1 Buck Converter

**Table 54-17. Buck Converter Electrical Characteristics**

Symbol	Parameter	Conditions	Min.	Typ.	Max.	Units
P <sub>EFF</sub>	Power Efficiency	I <sub>OUT</sub> = 100μA	-	66	-	%
		I <sub>OUT</sub> = 100mA	-	74	-	%

**Note:** To obtain the best power efficiency with buck regulator, the following components references must be used: L<sub>ext</sub> = LQH3NPN100MJOL, C<sub>out</sub> = GRM21BR71A475KA73.

**Table 54-18. External Components Requirements in Switching Mode<sup>(1)</sup>**

Symbol	Parameter	Conditions	Min.	Typ.	Max.	Units
C <sub>IN</sub> <sup>(2)</sup>	Input regulator capacitor		-	10	-	μF
		Ceramic dielectric X7R	-	100	-	nF
C <sub>OUT</sub> <sup>(3)</sup>	Output regulator capacitor		3.76	4.7	-	μF
		Ceramic dielectric X7R	-	100	-	nF
ESR C <sub>OUT</sub>	External Series Resistance of C <sub>OUT</sub>	-	-	-	0.5	Ω

# SAM D5x/E5x Family Data Sheet

## Electrical Characteristics at 85°C

.....continued

Symbol	Parameter	Conditions	Min.	Typ.	Max.	Units
$L_{EXT}$	External inductance		-	10	-	$\mu$ H
$R_{SERIES\_L_{EXT}}$	ESR of $L_{EXT}$	-	-	-	0.36	$\Omega$
$I_{SAT\_L_{EXT}}$	Saturation current	-	500	-	-	mA

**Note:**

1. These values are based on simulation. They are not covered by production test limits or characterization.
2. It is recommended to use ceramic X7R capacitor with low-series resistance. Refer to [Power Supply Connections](#) for a typical circuit connections.
3. It is recommended to use ceramic or solid tantalum capacitor with low ESR.

### 54.10.1.2 LDO Regulator

**Table 54-19. Decoupling Requirements**

Symbol	Parameter	Conditions	Min.	Typ.	Max.	Units
$C_{IN}^{(1)}$	Input regulator capacitor	-	-	10	-	$\mu$ F
		Ceramic dielectric X7R	-	100	-	nF
$C_{OUT}^{(2)}$	Output regulator capacitor	-	3.76	4.7	-	$\mu$ F
		Ceramic dielectric X7R	-	100	-	nF
ESR $C_{OUT}$	External Series Resistance of $C_{OUT}$	-	-	-	0.5	$\Omega$

**Note:**

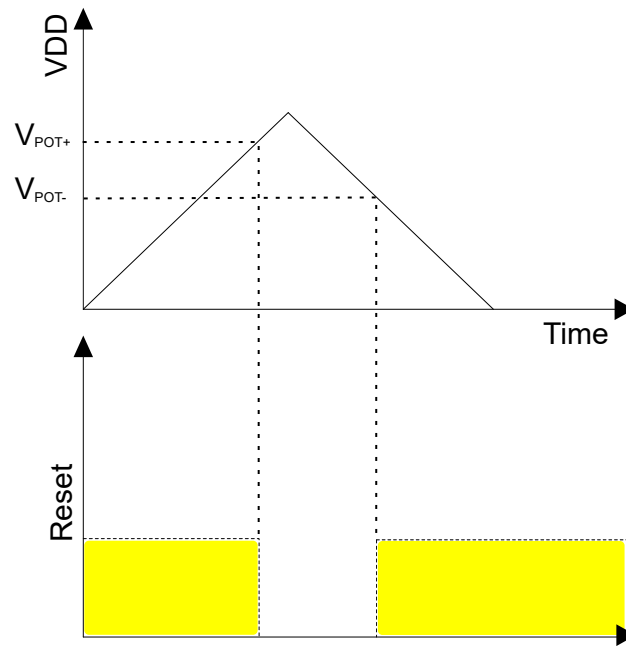
1. It is recommended to use ceramic X7R capacitor with low-series resistance. Refer to [Power Supply Connections](#) for a typical circuit connections.
2. It is recommended to use ceramic or solid tantalum capacitor with low ESR.

### 54.10.2 Power-On Reset (POR) Characteristics

**Table 54-20. POR Characteristics**

Symbol	Parameters	Min.	Typ.	Max.	Unit
$V_{POT+}$	Voltage threshold Level on $V_{DDIO}$ rising	1.53	1.58	1.64	V
$V_{POT-}$	Voltage threshold Level on $V_{DDIO}$ falling	0.97	1.26	1.35	V

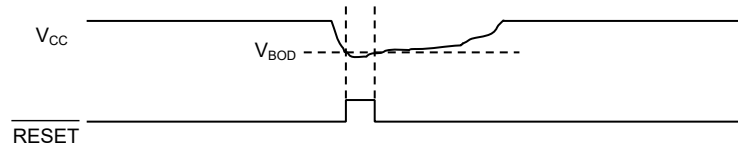
**Figure 54-1. POR Operating Principle**



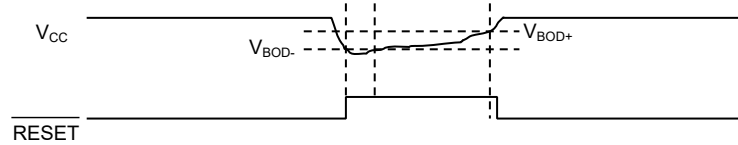
**Note:** The shaded area indicates that the device is in a Reset state.

### 54.10.3 Brown-Out Detectors (BOD) Characteristics

**Figure 54-3. BOD33 Hysteresis OFF**



**Figure 54-4. BOD33 Hysteresis ON**



# SAM D5x/E5x Family Data Sheet

## Electrical Characteristics at 85°C

**Table 54-21. BOD33 Characteristics on V<sub>DD</sub> and V<sub>BAT</sub> Monitoring in Normal Mode (During Power-up Phase and Active Mode)**

Symbol	Parameters	Conditions (see Notes 3, 4)	Min	Typ	Max	Unit
VBOD or VBOD- <sup>(1)</sup>	BOD33 threshold level Hysteresis OFF or BOD33 threshold level Hysteresis ON	LEVEL[7:0] = 0x00 (min)	1.463	1.509	1.544	V
		LEVEL[7:0] = 0x19 (recommended value)	1.609	1.658	1.697	
		LEVEL[7:0] = 0x1C (fuse value)	1.627	1.676	1.715	
		LEVEL[7:0] = 0xFF (max)	2.946	3.040	3.112	
VBOD+ <sup>(2)</sup>	BOD33 threshold level Hysteresis ON at power voltage rising	LEVEL[7:0] = 0x00 (min)	1.473	1.520	1.555	
		LEVEL[7:0] = 0x19 (recommended value)	1.618	1.669	1.707	
		LEVEL[7:0] = 0x1C (fuse value)	1.636	1.687	1.725	
		LEVEL[7:0] = 0xFF (max)	2.953	3.041	3.116	
Level_Step	DC threshold step	-	-	6.00	-	mV
Tstart	Startup time <sup>(6)</sup>	Time from enable to RDY	-	27	-	µs

**Note:**

1.  $VBOD = VBOD- = 1.5 + LEVEL[7:0] * Level\_Step$  LEVEL[7:0] is calibration setting bus of threshold level.
2.  $VBOD+ = VBOD- + N * HYST\_STEP$  N = 0 to 15 according to HYST[3:0] value HYST\_STEP = Level\_Step.
3. Hysteresis OFF mode, HYST[3:0] = 0x0.
4. Hysteresis ON mode, HYST[3:0] = 0x1 to 0xf; Min/Typ/Max values given for 0x2.
5. At the upper side of LEVEL[7:0] values depending on the Hysteresis value chosen with HYST[3:0], the VBOD+ level reaches an overflow, e.g., for HYST[3:0] = 0d2 the hysteresis is 2 x Level\_Step = 12 mV up to position 253 and position 254 to 255 above must not be used.
6. These are based on design simulation. They are not covered by production test limits or characterization.

# SAM D5x/E5x Family Data Sheet

## Electrical Characteristics at 85°C

**Table 54-22. BOD33 Characteristics on V<sub>DD</sub> and V<sub>BAT</sub> Monitoring in Low-Power Mode (During Standby/Backup/Hibernate Modes)**

Symbol	Parameters	Conditions (see Notes 3, 4)	Min	Typ	Max	Unit
VBOD or VBOD- <sup>(1)</sup>	BOD33 threshold level Hysteresis OFF or BOD33 threshold level Hysteresis ON	LEVEL[7:0] = 0x00 (min)	1.413	1.510	1.599	V
		LEVEL[7:0] = 0x19 (recommended value)	1.551	1.659	1.760	
		LEVEL[7:0] = 0x1C (fuse value)	1.569	1.677	1.778	
		LEVEL[7:0] = 0xFF (max)	2.845	3.045	3.229	
VBOD+ <sup>(2)</sup>	BOD33 threshold level Hysteresis ON at power voltage rising	LEVEL[7:0] = 0x00 (min)	1.426	1.522	1.611	
		LEVEL[7:0] = 0x19 (recommended value)	1.564	1.672	1.773	
		LEVEL[7:0] = 0x1C (fuse value)	1.582	1.690	1.791	
		LEVEL[7:0] = 0xFF (max)	2.848	3.045	3.230	
Level_Step	DC threshold step	-	-	6.00	-	mV
Tstart	Startup time <sup>(6)</sup>	Time from enable to RDY	-	27	-	µs

**Note:**

1.  $VBOD = VBOD- = 1.5 + LEVEL[7:0] * Level\_Step$  LEVEL[7:0] is calibration setting bus of threshold level.
2.  $VBOD+ = VBOD- + N * HYST\_STEP$  N = 0 to 15 according to HYST[3:0] value HYST\_STEP = Level\_Step.
3. Hysteresis OFF mode, HYST[3:0] = 0x0.
4. Hysteresis ON mode, HYST[3:0] = 0x1 to 0xf; Min/Typ/Max values given for 0x2.
5. At the upper side of LEVEL[7:0] values depending on the Hysteresis value chosen with HYST[3:0], the VBOD+ level reaches an overflow, e.g., for HYST[3:0] = 0d2 the hysteresis is 2 x Level\_Step = 12 mV up to position 253 and position 254 to 255 above must not be used.
6. These are based on design simulation. They are not covered by production test limits or characterization.



# SAM D5x/E5x Family Data Sheet

## Electrical Characteristics at 85°C

**Table 54-23. BOD33 Power Consumption**

Symbol	CPU Mode	Conditions	T <sub>A</sub>	Typ.	Max	Units
I <sub>DD</sub>	Active / Idle	VCC = 1.8V	Max 85°C Typ 25°C	8.52	12.07	μA
		VCC = 3.3V		10.10	14.28	
	Standby with BOD continuous normal mode	VCC = 1.8V		4.71	6.34	
		VCC = 3.3V		6.01	8.06	
	Standby with BOD continuous low power mode or Hibernate mode	VCC = 1.8V		0.15	0.22	
		VCC = 3.3V		0.21	0.30	

### 54.10.4 Analog-to-Digital Converter (ADC) Characteristics

**Table 54-24. Operating Conditions<sup>(1)</sup>**

Symbol	Parameters	Conditions	Min.	Typ.	Max.	Unit
Res	Resolution		-	-	12	bits
F <sub>CNV</sub>	Sampling rate - Differential mode SAMPCTRL.OFFCOMP = 0 REFCTRL.REFCOMP = 0	resolution 12 bit (CTRLB.RESSEL=0)	10	-	1231	ksps
		resolution 10 bit (CTRLB.RESSEL=2)	14.55	-	1455	
		resolution 8 bit (CTRLB.RESSEL=3)	17.78	-	1778	
	Sampling rate - Single-Ended mode SAMPCTRL.OFFCOMP = 0 REFCTRL.REFCOMP = 0	resolution 12 bit (CTRLB.RESSEL=0)	10	-	1231	ksps
		resolution 10 bit (CTRLB.RESSEL=2)	13.33	-	1333	
		resolution 8 bit (CTRLB.RESSEL=3)	16	-	1600	
Conversion delay	Differential mode Number of ADC clock cycles SAMPCTRL.OFFCOMP=1 and/or REFCTRL.REFCOMP=1	resolution 12 bit (CTRLB.RESSEL=0)	16			cycles
		resolution 10 bit (CTRLB.RESSEL=2)	14			
		resolution 8 bit (CTRLB.RESSEL=3)	12			
	Differential mode Number of ADC clock cycles SAMPCTRL.OFFCOMP=0 REFCTRL.REFCOMP=0 SAMPLEN corresponds to the decimal value of SAMPCTRL.SAMPLEN[5:0] register	resolution 12 bit (CTRLB.RESSEL=0)	SAMPLEN+13			cycles
		resolution 10 bit (CTRLB.RESSEL=2)	SAMPLEN+11			
		resolution 8 bit (CTRLB.RESSEL=3)	SAMPLEN+9			
	Single-ended mode Number of ADC clock cycles SAMPCTRL.OFFCOMP=1 and/or REFCTRL.REFCOMP=1	resolution 12 bit (CTRLB.RESSEL=0)	16			cycles
		resolution 10 bit (CTRLB.RESSEL=2)	15			
		resolution 8 bit (CTRLB.RESSEL=3)	13			
	Single-ended mode Number of ADC clock cycles SAMPCTRL.OFFCOMP=0 REFCTRL.REFCOMP=0 SAMPLEN corresponds to the decimal value of SAMPCTRL.SAMPLEN[5:0] register	resolution 12 bit (CTRLB.RESSEL=0)	SAMPLEN+13			cycles
		resolution 10 bit (CTRLB.RESSEL=2)	SAMPLEN+12			
		resolution 8 bit (CTRLB.RESSEL=3)	SAMPLEN+10			
F <sub>ADC</sub>	ADC Clock frequency		160	F <sub>cnv</sub> *Nb_cycles	16000	kHz

# SAM D5x/E5x Family Data Sheet

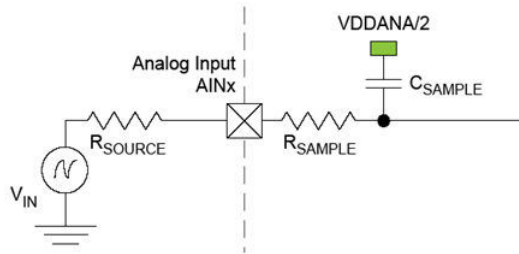
## Electrical Characteristics at 85°C

.....continued						
Symbol	Parameters	Conditions	Min.	Typ.	Max.	Unit
T <sub>S</sub>	Sampling time	SAMPCTRL.OFFCOMP=1 REFCTRL.REFCOMP=1 CTRLC.R2R=1	4			Cycles
		SAMPCTRL.OFFCOMP=0 <sup>(3)</sup> REFCTRL.REFCOMP=0 CTRLC.R2R=0	1	-	65	
	Sampling time with DAC as input	SAMPCTRL.OFFCOMP=1 REFCTRL.REFCOMP=1 CTRLC.R2R=1	(4)			ns
		SAMPCTRL.OFFCOMP=0 <sup>(3)</sup> REFCTRL.REFCOMP=0 CTRLC.R2R=0				
	Sampling time with Temp Sensor or Bandgap as input	SAMPCTRL.OFFCOMP=1 REFCTRL.REFCOMP=1 CTRLC.R2R=1	10000	-	4/fadcmin = 25000	
		SAMPCTRL.OFFCOMP=0 <sup>(3)</sup> REFCTRL.REFCOMP=0 CTRLC.R2R=0	10000	-	65/fadcmin = 406250	
VCNV	Conversion range	Differential mode	-VREF	-	+VREF	V
	Conversion range	Single-ended mode	0	-	VREF	
VREF	Reference input	-	1.0	-	VDDANA-0.4	V
V <sub>IN</sub>	Input channel range	-	0	-	VDDANA	V
V <sub>CMIN</sub>	Input common mode voltage	CTRLA.R2R=1	0	-	VDDANA	V
		CTRLA.R2R=0	See Note 2			V
CSAMPLE	Input sampling capacitance		2	2.5	3	pF
RSAMPLE	Input sampling on-resistance		-		2000	Ω
RREF	Reference source resistance			-	2.5	kΩ

**Note:**

- These values are based on simulation. They are not covered by production test limits or characterization.
- Limit the input common mode voltage using the following equations (where, V<sub>CM\_IN</sub> is the input channel common mode voltage):  
When CTRLA.R2R = 0:
  - V<sub>CM\_IN</sub> < 0.75\*VREF
  - V<sub>CM\_IN</sub> > Maximum of (0, VREF-VDDANA-0.7, 1.25\*VREF-VDDANA)
- When SAMPCTRL.OFFCOMP is disabled, T<sub>S</sub> is a function of the SAMPLLEN[5:0] register value.
- See T<sub>S</sub> specified in DAC Electrical Characteristics.

**Figure 54-5. ADC Analog Input AINx**



The minimum sampling time  $t_{\text{samplehold}}$  for a given  $R_{\text{source}}$  can be found using a general formula:

$$t_{\text{samplehold}} \geq (R_{\text{sample}} + R_{\text{source}}) \times C_{\text{sample}} \times (n + 2) \times \ln(2)$$

For 12-bit accuracy, this turns into:

$$t_{\text{samplehold}} \geq (R_{\text{sample}} + R_{\text{source}}) \times C_{\text{sample}} \times 9.7$$

$$\text{where } t_{\text{samplehold}} \geq \frac{1}{2 \times f_{\text{ADC}}}.$$

**Table 54-25. Differential Mode <sup>(1)</sup>**

Symbol	Parameter	Conditions	Measurement			Unit	
			Min	Typ	Max		
ENOB	Effective Number of bits	Fadc = 1Msps - R2R disabled	Vddana=3.0V Vref=Vddana	10.5	10.8	11.2	bits
			Vddana=3.0V ExtVref=2.0V	10.5	10.8	11.0	
TUE	Total Unadjusted Error (2)	Fadc = 1Msps - R2R disabled	Vddana=3.0V Vref=Vddana	-	+/-2.3	+/-5.2	LSB
			Vddana=3.0V ExtVref=2.0V	-	+/-2.7	+/-5.6	
INL	Integral Non Linearity	Fadc = 1Msps - R2R disabled	Vddana=3.0V Vref=Vddana	-	+/-1.2	+/-1.5	LSB
			Vddana=3.0V ExtVref=2.0V	-	+/-1.2	+/-1.5	
DNL	Differential Non Linearity	Fadc = 1Msps - R2R disabled	Vddana=3.0V Vref=Vddana	-	+/-0.98	-1/+1	LSB
			Vddana=3.0V ExtVref=2.0V	-	+/-0.95	-1/+1	
Gain	Gain Error with REFCTRL.REFCOMP=1	Fadc = 1Msps	Vddana=3.0V Vref=Vddana	-0.18	-0.02	+0.16	%
			Vddana=3.0V ExtVref=2.0V	-0.09	+0.03	+0.18	
			Vddana=3.0V 1V internal Ref	-4.3	-1	+1.8	
			Vddana=3.0V Vref=Vddana/2	-0.35	+0.2	+0.65	
	Gain Error with REFCTRL.REFCOMP=0	Fadc = 1Msps	Vddana=3.0V Vref=Vddana	-0.2	-0.001	+0.16	
			Vddana=3.0V ExtVref=2.0V	-0.74	-0.05	0.66	
			Vddana=3.0V 1V internal Ref	-4.9	-1	+1.6	
			Vddana=3.0V Vref=Vddana/2	-1	+0.11	+1	
Offset	Offset Error with SAMPCTRL.OFFCOMP=1	Fadc = 1Msps	Vddana=3.0V Vref=Vddana	-2.9	-0.3	+2.4	mV
			Vddana=3.0V ExtVref=2.0V	-2.6	-0.2	+2.1	
			Vddana=3.0V 1V internal Ref	-2.3	-0.2	+2.3	
			Vddana=3.0V Vref=Vddana/2	-2.9	-0.3	+2.6	
	Offset Error with SAMPCTRL.OFFCOMP=0	Fadc = 1Msps	Vddana=3.0V Vref=Vddana	-9.5	+0.03	+9.9	
			Vddana=3.0V ExtVref=2.0V	-9.9	-0.03	+9.8	
			Vddana=3.0V 1V internal Ref	-5	+0.5	-5	
			Vddana=3.0V Vref=Vddana/2	-10.8	+0.5	+11.3	

# SAM D5x/E5x Family Data Sheet

## Electrical Characteristics at 85°C

.....continued

Symbol	Parameter	Conditions		Measurement			Unit
				Min	Typ	Max	
SFDR	Spurious Free Dynamic Range	Fs = 1Msps Fin = 14kHz (2)	Vddana=3.0V Vref=Vddana	76.6	79.6	83.5	dB
SINAD	Signal to Noise and Distortion ratio			65.3	67.2	68.9	
SNR	Signal to Noise ratio			64.7	66.5	68.2	
THD	Total Harmonic Distortion			-91.6	-82.9	-78.6	
Nrms	Noise RMS	constant input voltage	Vddana=3.0V ExtVref=2.0V	0.2	0.4	2.4	mV
			Vddana=3.0V Vref=Vddana	0.15	0.25	2.5	

**Note:**

1. These values are based on characterization. These values are not covered by test limits in production.
2. All values expressed in decibel refer to the full scale input and are tested with an input signal 0.35dB below full scale; THD measured on the first seven harmonics of the input signal.

**Table 54-26. Single Ended Mode <sup>(1)</sup>**

Symbol	Parameter	Conditions		Measurement			Unit
				Min	Typ	Max	
ENOB	Effective Number of bits	Fadc = 1Msps - R2R disabled	Vddana=3.0V Vref=Vddana	8.9	9.25	9.9	bits
			Vddana=3.0V ExtVref=2.0V	8.9	9.5	9.7	
TUE	Total Unadjusted Error (2)	Fadc = 1Msps - R2R disabled	Vddana=3.0V Vref=Vddana	-	+/-10.9	+/-18.3	LSB
			Vddana=3.0V ExtVref=2.0V	-	+/-9.7	+/-19.1	
INL	Integral Non Linearity	Fadc = 1Msps - R2R disabled	Vddana=3.0V Vref=Vddana	-	+/-2.3	+/-3.2	LSB
			Vddana=3.0V ExtVref=2.0V	-	+/-2.3	+/-3	
DNL	Differential Non Linearity	Fadc = 1Msps - R2R disabled	Vddana=3.0V Vref=Vddana	-	+/-0.98	-1/+1	LSB
			Vddana=3.0V ExtVref=2.0V	-	+/-0.97	-1/+1.1	
Gain	Gain Error with REFCTRL.REFCOMP=1	Fadc = 1Msps	Vddana=3.0V Vref=Vddana	-0.3	-0.01	+0.3	%
			Vddana=3.0V ExtVref=2.0V	-0.2	+0.02	+0.25	
			Vddana=3.0V 1V internal Ref	-4.2	-1.1	+1.8	
			Vddana=3.0V Vref=Vddana/2	-0.4	+0.1	+0.6	
Offset	Offset Error with SAMPCTRL.OFFCOMP=1	Fadc = 1Msps	Vddana=3.0V Vref=Vddana	-18	-7.2	+7	mV
			Vddana=3.0V ExtVref=2.0V	-18.6	-2.9	+13	
			Vddana=3.0V 1V internal Ref	-24	-4.2	+19	
			Vddana=3.0V Vref=Vddana/2	-22	-3.1	+24	
SFDR	Spurious Free Dynamic Range	Fs = 1Msps Fin = 14kHz (2)	Vddana=3.0V Vref=Vddana	67.9	69.2	76.3	dB
SINAD	Signal to Noise and Distortion ratio			55.7	57.5	61.1	
SNR	Signal to Noise ratio			54.7	56.9	60.6	
THD	Total Harmonic Distortion			-73.7	-68.2	-65.8	
Nrms	Noise RMS	constant input voltage	Vddana=3.0V ExtVref=2.0V	0.35	1.0	2.1	mV
			Vddana=3.0V Vref=Vddana	0.3	0.35	1.7	

# SAM D5x/E5x Family Data Sheet

## Electrical Characteristics at 85°C

**Note:**

1. These values are based on characterization. These values are not covered by test limits in production.
2. All values expressed in decibel refer to the full scale input and are tested with an input signal 0.35dB below full scale; THD measured on the first seven harmonics of the input signal.

**Table 54-27. Power Consumption**

Symbol	Parameters	Conditions	Ta	Typ.	Max	Units				
IDD VDDANA	Differential mode	fs = 1 Msps / Reference buffer disabled / BIASREFBUF = '111', BIASREFCOMP = '111' VDDANA = VREF = 3.0V	Max 85°C Typ 25°C	279	318	µA				
		fs = 1 Msps / Reference buffer enabled / BIASREFBUF = '111', BIASREFCOMP = '111' VDDANA = VREF = 3.0V					482	653		
		fs = 10 ksps / Reference buffer disabled / BIASREFBUF = '111', BIASREFCOMP = '111' VDDANA = VREF = 3.0V					28	45		
		fs = 10 ksps / Reference buffer enabled / BIASREFBUF = '111', BIASREFCOMP = '111' VDDANA = VREF = 3.0V					241	397		
	Single Ended mode	fs = 1 Msps / Reference buffer disabled / BIASREFBUF = '111', BIASREFCOMP = '111' VDDANA = VREF = 3.0V		Max 85°C Typ 25°C	307		348	µA		
		fs = 1 Msps / Reference buffer enabled / BIASREFBUF = '111', BIASREFCOMP = '111' VDDANA = VREF = 3.0V							499	681
		fs = 10 ksps / Reference buffer disabled / BIASREFBUF = '111', BIASREFCOMP = '111' VDDANA = VREF = 3.0V							38	60
		fs = 10 ksps / Reference buffer enabled / BIASREFBUF = '111', BIASREFCOMP = '111' VDDANA = VREF = 3.0V							245	400

### 54.10.5 Digital to Analog Converter (DAC) Characteristics

**Table 54-28. Operating Conditions <sup>(1)</sup>**

Symbol	Parameters	Conditions	Min.	Typ.	Max.	Unit
Res	Resolution	-	-	-	12	bits
clk	Internal DAC Clock frequency	-	-	-	12	MHz
fs_dac	Sampling frequency	clk/12, CCTRL=0x0 (Low Power)	-	-	10	ksps
		clk/12, CCTRL=0x2 (High Power)	-	-	1	Mbps
VOUTmin	Min. Output Voltage	-	-	-	0.15	V
VOUTmax	Max. Output Voltage	-	VDDANA-0.15	-	-	
VREF	External Reference input	CTRLB.REFSEL[1:0]=0x2 (VREFAB)	1	-	VDDANA-0.15	V
		CTRLB.REFSEL[1:0]=0x0 (VREFAU)	1	-	VDDANA	
CVREF	External decoupling capacitor	-	-	220	-	nF
CLOAD	Output capacitor load	-	-	-	50	pF
RLOAD	Output resistance load	-	5	-	-	kΩ
ts	Settling time	For reaching ±1LSB of the final value. Step size < 500 LSB - Cload = 50pF	-	-	1	µs
ts_FS	Settling time 0x080 to 0xF7F	For reaching ±1LSB of the final value. Step size from 0% to 100% - Cload = 50pF	-	5	7	µs

# SAM D5x/E5x Family Data Sheet

## Electrical Characteristics at 85°C

**Note:**

1. These values are based on simulation. They are not covered by production test limits or characterization.

**Table 54-29. Differential Mode <sup>(1)</sup>**

Symbol	Parameters	Conditions	Min.	Typ.	Max.	Unit
INL	Integral Non Linearity, Best-fit curve from 0x080 to 0xF7F	i12clk = 12 MHz, V <sub>DDANA</sub> = 3.0V, External Ref. = 2.0V, C <sub>LOAD</sub> = 50 pF	-	±2.4	±3.4	LSB
		i12clk = 12 MHz, V <sub>DDANA</sub> = 3.0V, Internal Ref, C <sub>LOAD</sub> = 50 pF	-	±3.2	±4.2	
DNL	Differential Non Linearity, Best-fit curve from 0x080 to 0xF7F	i12clk = 12 MHz, V <sub>DDANA</sub> = 3.0V, External Ref. = 2.0V, C <sub>LOAD</sub> = 50 pF	-	±2.4	±3.6	LSB
		i12clk = 12 MHz, V <sub>DDANA</sub> = 3.0V, Internal Ref, C <sub>LOAD</sub> = 50 pF	-	±3.5	±5.4	
Gerr	Gain Error	External Reference voltage	-	±0.4	±1.7	% FSR
		1.0V Internal Reference voltage	-	±0.8	±7.0	
Offerr	Offset Error	External Reference voltage	-	±13	±40	mV
		1.0V Internal Reference voltage	-	±8	±64	
ENOB	Effective Number Of Bits	Fs = 1 Ms/s - External Ref - CCTRL = 0x2	9.9	10.7	10.9	Bits
SNR	Signal to Noise ratio		63.5	68.6	72.6	dB
THD	Total Harmonic Distortion		-79.1	-72.5	-61.0	dB

**Note:**

1. These values are based on characterization. These values are not covered by test limits in production.

**Table 54-30. Single-Ended Mode <sup>(1)</sup>**

Symbol	Parameters	Conditions	Min.	Typ.	Max.	Unit
INL	Integral Non Linearity, Best-fit curve from 0x080 to 0xF7F	i12clk = 12 MHz, V <sub>DDANA</sub> = 3.0V External Ref. = 2.0V, C <sub>LOAD</sub> = 50 pF	-	±2.7	±4.0	LSB
		i12clk = 12 MHz V <sub>DDANA</sub> = 3.0V, Internal Ref, C <sub>LOAD</sub> = 50 pF	-	±5.2	8.2	
DNL	Differential Non Linearity, Best-fit curve from 0x080 to 0xF7F	i12clk = 12 MHz, V <sub>DDANA</sub> = 3.0V External Ref = 2.0V, C <sub>LOAD</sub> = 50 pF	-	±3.5	±6.1	LSB
		i12clk = 12 MHz V <sub>DDANA</sub> = 3.0V, Internal Ref, C <sub>LOAD</sub> = 50 pF	-	±6.4	±9.4	
Gerr	Gain Error	External Reference voltage	-	±0.3	±1.5	% FSR
		1.0V Internal Reference voltage	-	±0.8	±6.9	

# SAM D5x/E5x Family Data Sheet

## Electrical Characteristics at 85°C

.....continued

Symbol	Parameters	Conditions	Min.	Typ.	Max.	Unit
Offerr	Offset Error	External Reference voltage	-	±7	±21	mV
		1.0V Internal Reference voltage	-	±2	±16	
ENOB	Effective Number of Bits	Fs = 1 Ms/s - External Ref - CCTRL = 0x2	9.1	10.3	10.7	Bits
SNR	Signal to Noise Ratio		63.5	68.6	72.6	dB
THD	Total Harmonic Distortion		-79.1	-72.8	-61.0	dB

**Note:**

1. These values are based on characterization. These values are not covered by test limits in production.

**Table 54-31. Power Consumption**

Symbol	Parameters	Conditions	Ta	Min.	Typ.	Max.	Unit
IDDANA	Differential Mode, DC supply current, 2 output channels - without load	fs = 1 Msps, CCTRL = 0x2, VREF > 2.4V, VCC = 3.3V	Max. 85°C Typ. 25°C	-	384	540	µA
		fs = 10 ksps, CCTRL = 0x0, VREF < 2.4V, VCC = 3.3V		-	283	411	
	Single-Ended Mode, DC supply current, 2 output channels - without load	fs = 1 Msps, CCTRL = 0x2, VREF > 2.4V, VCC = 3.3V		-	306	443	µA
		fs = 10 ksps, CCTRL = 0x0, VREF < 2.4V, VCC = 3.3V		-	230	332	

### 54.10.6 Analog Comparator (AC) Characteristics

**Table 54-32. Analog Comparator Characteristics**

Symbol	Parameters	Conditions	Min	Typ	Max	Unit
PNIVR <sup>(1)</sup>	Positive and Negative input range voltage		0	-	VDDANA	V
ICMR <sup>(1)</sup>	Input common mode range		0	-	VDDANA-0.2	V
Off <sup>(2)</sup>	Offset	High speed COMPCTRLn.SPEED = 0x3	-18	±3	18	mV
Tpd	Propagation Delay Vcm=Vddana/2, Vin = +/-100mV overdrive from Vcm	High speed COMPCTRLn.SPEED = 0x3	-	24.1	39	ns
Tstart	Startup time	High speed COMPCTRLn.SPEED = 0x3	-	4.7	7.5	µs

# SAM D5x/E5x Family Data Sheet

## Electrical Characteristics at 85°C

### Note:

1. These values are based on simulation. They are not covered by production test limits or characterization.
2. Hysteresis disabled.

**Table 54-33. Power Consumption**

Symbol	Parameters	Conditions	Ta	Typ.	Max.	Unit
I <sub>DDANA</sub>	Current consumption for One AC enabled, Hysteresis disabled voltage scaler disabled	COMPCTRLn.SPEED=0x3, V <sub>DDANA</sub> =3.3V	Max.85°C Typ.25°C	59	93	μA
	Current consumption Voltage Scaler only	V <sub>DDANA</sub> =3.3V		11	21	

### 54.10.7 Voltage References

**Table 54-34. Reference Voltage Characteristics**

Symbol	Parameter	Conditions	Min.	Typ.	Max.	Units
ADC/DAC Ref	ADC/DAC internal reference ADC.REFCTRL.REFSEL = INTREF DAC.CTRLB.REFSEL = INTREF AC.COMPCTRLn.MUXNEG = BANDGAP	nom. 1.0V, V <sub>DDANA</sub> =3.3V, T= 25°C	0.954	1.0	1.044	V
		nom. 1.1V, V <sub>DDANA</sub> =3.3V, T= 25°C	1.060	1.1	1.139	
		nom. 1.2V, V <sub>DDANA</sub> =3.3V, T= 25°C	1.150	1.2	1.248	
		nom. 1.25V, V <sub>DDANA</sub> =3.3V, T= 25°C	1.207	1.3	1.291	
		nom. 2.0V, V <sub>DDANA</sub> =3.3V, T= 25°C	1.893	2.0	2.102	
		nom. 2.2V, V <sub>DDANA</sub> =3.3V, T= 25°C	2.092	2.2	2.303	
		nom. 2.4V, V <sub>DDANA</sub> =3.3V, T= 25°C	2.282	2.4	2.513	
		nom. 2.5V, V <sub>DDANA</sub> =3.3V, T= 25°C	2.380	2.5	2.615	
		Ref Temperature coefficient	drift over [-40, +25]°C	-	-0.01/+0.03	
		drift over [+25, +85]°C	-	-0.02/+0.02	-	
	Ref Supply coefficient	drift over [1.71, 3.6]V	-	-0.2/+0.7	-	% / V
AC Ref	AC Internal Bandgap Reference	nom.1.1V, V <sub>DDANA</sub> = 3.3V, T = 25°C	1.074	1.1	1.125	



# SAM D5x/E5x Family Data Sheet

Electrical Characteristics at 85°C

## 54.11 PTC Characteristics

Table 54-35. Sensor Load Capacitance

Symbol	Mode	PTC channel	Max Sensor Load <sup>(1)</sup>	Units	
Cload	Self-capacitance	Y0	54	pF	
		Y1			
		Y2			
		Y3			
		Y4			
		Y5			
		Y6			
		Y7			
		Y8			
		Y9			
		Y10			
		Y11			
		Y12			
		Y13			
		Y14			
		Y15			
		Y16			51
		Y17			54
		Y18			
		Y19			
		Y20			51
		Y21			
		Y22			
		Y23			54
		Y24			
		Y25			
		Y26			
		Y27			
		Y28			
		Y29			
		Y30			
	Y31				
		Mutual-capacitance	All		31

**Note:**

1. Capacitance load that the PTC circuitry can compensate for each channel.

**Table 54-36. Analog Gain Settings** <sup>(1)</sup> <sup>(2)</sup>

Symbol	Setting	Average
Gain	GAIN_1	1
	GAIN_2	2.0
	GAIN_4	4.2
	GAIN_8	9.1
	GAIN_16	15.4
	GAIN_32	-

**Note:**

1. Analog Gain is a parameter of the QTouch Library. Refer to the “QTouch Library Peripheral Touch Controller User Guide” for additional information.
2. The GAIN\_16 and GAIN\_32 settings are not recommended; otherwise, the PTC measurements might become unstable.

The values in the following Power Consumption table are measured values of power consumption under the following conditions:

**Operating Conditions:**

VDD = 3.0V

**Clocks:**

DFLL48M used as main clock source, running undivided at 48 MHz

CPU is running on flash with 2 wait states, at 48 MHz

PTC running at 4 MHz

**PTC Configuration**

Mutual-Capacitance mode

One touch channel

**System Configuration**

Standby Sleep mode enabled

RTC running on ULP32K: used to define the PTC scan rate, through the event system

RTC interrupts (wake up) the CPU to perform PTC scans

# SAM D5x/E5x Family Data Sheet

## Electrical Characteristics at 85°C

**Table 54-37. Power Consumption (1)**

Symbol	Parameters	PTC scan rate (msec)	Oversamples	Ta	Typ.	Max	Units
IDD	Current Consumption	10	4	Max 85°C Typ 25°C	137	1164	μA
			16		146	1179	
		50	4		77	1094	
			16		79	1100	
		100	4		68	1086	
			16		69	1089	
		200	4		64	1085	
			16		65	1087	

**Note:**

1. These values are based on characterization.

### 54.12 NVM Characteristics

**Table 54-38. NVM Flash Read Wait States for Worst Case Conditions (EFP part numbers)**

CPU Fmax (Mhz)	0 WS	1 WS	2 WS	3 WS	4 WS	5 WS	6 WS	Auto WS
Read Operations	1 Cycle	2 Cycles	3 Cycles	4 Cycles	5 Cycles	6 Cycles	7 Cycles	n Cycles
VDD>1.71V	19	38	57	76	95	100	120	120

**Table 54-39. NVM Flash Read Wait States for Worst Case Conditions (non-EFP part numbers)**

CPU Fmax(MHz)	0 WS	1 WS	2 WS	3 WS	4 WS	5 WS	Auto WS
Read Operations	1 Cycle	2 Cycles	3 Cycles	4 Cycles	5 Cycles	6 Cycles	N Cycles
VDD > 2.7V	24	51	77	101	119	120	120
VDD > 1.71V	22	44	67	89	111	120	120

Maximum operating frequencies are given in the table above in MHz, but are limited by the Embedded Flash access time when the processor is fetching code out of it. These tables provide the device maximum operating frequency defined by the field RWS of the NVMCTRL CTRLA register when automatic wait states (AUTOWS) is disabled. This field defines the number of Wait states required to access the Embedded Flash Memory.

**Table 54-40. Flash Timing Characteristics**

Symbol	Parameter	Conditions	Min.	Typ.	Max.	Units
t <sub>FPW</sub>	Program Cycle Time	Write Page		1.5	3 <sup>(1)</sup>	ms
t <sub>CE</sub>		Chip Erase		6.4	25 <sup>(1)</sup>	s
t <sub>FEB</sub>		Erase Block		50	200 <sup>(1)</sup>	ms

**Note:**

1. These are based on simulation. They are not covered by production test limits or characterization.

**Table 54-41. Flash Endurance and Data Retention**

Symbol	Parameter	Conditions	Min.	Typ.	Units
Ret <sub>NVM10k</sub>	Retention after up to 10k	At TA = 85°C	20	-	Years
Cyc <sub>NVM</sub>	Cycling Endurance <sup>(1)</sup>	At TA = 85°C	10K	-	Cycles

**Note:**

1. An endurance cycle is a write-and-erase operation.

**Table 54-42. Flash Erase and Programming Current<sup>(1)</sup>**

Symbol	Parameter	Typ.	Max.	Units
I <sub>FAP</sub>	Active Current current during whole programming operation	8		mA
I <sub>FAE</sub>	Active Current current during Erase operation	8		mA

**Note:**

1. These values are based on simulation. They are not covered by production test limits or characterization.

## 54.13 Oscillators Characteristics

### 54.13.1 Crystal Oscillator (XOSC) Characteristics

#### Digital Clock Characteristics

The following table describes the characteristics for the oscillator when a digital clock is applied on XIN.

**Table 54-43. Digital Clock Characteristics**

Symbol	Parameter	Min.	Typ.	Max.	Units
F <sub>XIN</sub>	XIN clock frequency	-	-	48	MHz
DC <sub>XIN</sub> (see <b>Note 1</b> )	XIN clock duty cycle	40		60	%

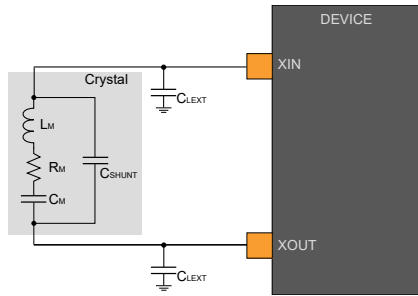
**Note:**

1. These values are based on simulation. They are not covered by production test limits or characterization.

#### Chrystal Oscillator Characteristics

The following Table describes the characteristics for the oscillator when a crystal is connected between XIN and XOUT.

**Figure 54-6. Oscillator Connection**



The user must choose a crystal oscillator where the crystal load capacitance  $C_L$  is within the range given in the Table. The exact value of  $C_L$  can be found in the crystal datasheet. The capacitance of the external capacitors ( $C_{LEXT}$ ) can then be computed as follows:

$$C_{LEXT} = 2 * (C_L - C_{PARA} - C_{PCB} - C_{SHUNT})$$

Where:

- $C_{PARA}$  is the internal load capacitor parasitic between XIN and XOUT and can be computed as following:

**Equation 54-1.**

$$C_{PARA} = \frac{(C_{XIN} * C_{XOUT})}{(C_{XIN} + C_{XOUT})}$$

- $C_{PCB}$  is the capacitance of the PCB
- $C_{SHUNT}$  is the shunt capacitance of the crystal as specified by the crystal manufacturer

**Table 54-44. Multi-Crystal Oscillator Electrical Characteristics**

Symbol	Parameter	Conditions	Min.	Typ.	Max.	Units
F <sub>OUT</sub>	Crystal oscillator frequency		8	-	48	MHz
C <sub>L</sub>	Crystal Load	F = 8 MHz	-	-	20	pF
		F = 16 MHz	-	-	20	
		F = 32 MHz	-	-	13	
		F = 48 MHz	-	-	13	
ESR	Crystal Equivalent Series Resistance - SF=3	F = 8 MHz, C <sub>L</sub> =20 pF - IMULT = 0x3	-	-	181	Ω
		F = 16 MHz, C <sub>L</sub> = 20 pF - IMULT = 0x4	-	-	180	
		F = 24 MHz, C <sub>L</sub> = 20 pF - IMULT = 0x5	-	-	70	
		F = 48 MHz, C <sub>L</sub> = 13 pF - IMULT = 0x6	-	-	70	
C <sub>XIN</sub>	Parasitic load capacitor		-	6.3	-	pF
C <sub>XOUT</sub>			-	5.9	-	
D <sub>L</sub>	Drive Level (1)	ENALC = ON	-	-	100	μW
T <sub>START</sub>	Startup time	F = 8 MHz, C <sub>L</sub> = 20 pF, C <sub>SHUNT</sub> = 2 pF - IMULT = 0x3	-	39700	72200	Cycles
		F = 16 MHz, C <sub>L</sub> = 20 pF, C <sub>SHUNT</sub> = 1.5 pF - IMULT = 0x4	-	37550	62000	
		F = 24 MHz, C <sub>L</sub> = 20 pF, C <sub>SHUNT</sub> = 2.5 pF - IMULT = 0x5	-	32700	68500	
		F = 48 MHz, C <sub>L</sub> = 13 pF, C <sub>SHUNT</sub> = 5 pF - IMULT = 0x6	-	18400	38500	

# SAM D5x/E5x Family Data Sheet

## Electrical Characteristics at 85°C

### Note:

- To ensure that the crystal is not overdriven, the automatic loop control is recommended to be turned ON (ENALC = 1).

**Table 54-45. Power Consumption**

Symbol	Parameters	Conditions	Ta	Typ.	Max.	Units
I <sub>DD</sub>	Current Consumption	F = 8 MHz - C <sub>L</sub> = 20 pF - IMULT = 0x3, ENALC = OFF	Max. 85°C, Typ. 25°C	0.43	1.02	mA
		ENALC = ON		0.16	0.66	
		F = 16 MHz - C <sub>L</sub> = 20 pF - IMULT = 0x5, ENALC = OFF		1.31	2.39	
		ENALC = ON		0.25	0.81	
		F = 32 MHz - C <sub>L</sub> = 13 pF - IMULT = 0x5, ENALC = OFF		2.92	4.75	
		ENALC = ON		0.40	1.09	
		F = 48 MHz - C <sub>L</sub> = 13 pF - IMULT = 0x6, ENALC = OFF		2.70	4.79	
		ENALC = ON		0.76	1.46	

### 54.13.2 External 32 kHz Crystal Oscillator (XOSC32K) Characteristics

#### Digital Clock Characteristics

The following table describes the characteristics for the oscillator when a digital clock is applied on XIN32 pin.

**Table 54-46. Digital Clock Characteristics<sup>(1)</sup>**

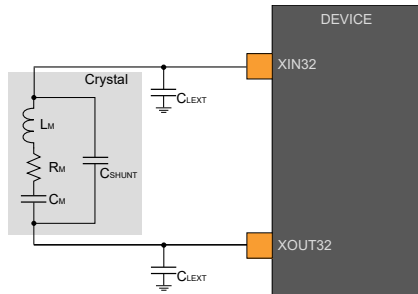
Symbol	Parameter	Min.	Typ.	Max.	Units
f <sub>CPXIN32</sub>	XIN32 clock frequency		32.768		kHz
DC <sub>XIN</sub>	XIN32 clock duty cycle		50		%

**Note:** 1. These values are based on simulation. They are not covered by production test limits or characterization.

#### Crystal Oscillator Characteristics

The following section describes the characteristics for the oscillator when a crystal is connected between XIN32 and XOUT32 pins.

**Figure 54-7. Oscillator Crystal Connection**



The user must choose a crystal oscillator where the crystal load capacitance  $C_L$  is within the range given in the table. The exact value of  $C_L$  can be found in the crystal data sheet. The capacitance of the external capacitors ( $C_{LEXT}$ ) can then be computed as follows:

$$C_{LEXT} = 2 * (C_L - C_{PARA} - C_{PCB} - C_{SHUNT})$$

Where:

- $C_{PARA}$  is the internal load capacitor parasitic between XIN32 and XOUT32 and can be computed as following:

**Equation 54-2.**

$$C_{PARA} = \frac{(C_{XIN32k} * C_{XOUT32k})}{(C_{XIN32k} + C_{XOUT32k})}$$

- $C_{PCB}$  is the capacitance of the PCB
- $C_{SHUNT}$  is the shunt capacitance of the crystal as specified by the crystal manufacturer

**Table 54-47. 32 kHz Crystal Oscillator Electrical Characteristics**

Symbol	Parameter	Conditions	Min.	Typ.	Max.	Units	
$F_{OUT}^{(1)}$	Crystal oscillator frequency	-	-	32.768	-	kHz	
$CL^{(1)}$	Crystal load capacitance	-	-	-	12.5	pF	
$CSHUNT^{(1)}$	Crystal shunt capacitance	-	-	-	1.7	pF	
$CM^{(1)}$	Motional capacitance	-	2	-	7	fF	
ESR	Crystal Equivalent Series Resistance - SF=3	f=32.768 kHz, $C_L=12.5$ pF	Std. Gain	-	-	58	kΩ
		High Gain	-	-	90		
$C_{XIN32k}$	Parasitic load capacitor	-	-	3.1	-	pF	
$C_{XOUT32k}$		-	-	3.2	-		
$t_{STARTUP}$	Startup time	f=32.768 kHz, $C_L=12.5$ pF, $C_M=2.0$ fF	Std. Gain	-	12	28	kCycles
			High Gain	-	9	23	

**Note:**

1. These values are based on simulation. They are not covered by production test limits or characterization.

# SAM D5x/E5x Family Data Sheet

## Electrical Characteristics at 85°C

**Table 54-48. Power Consumption**

Symbol	Parameter	Conditions	Ta	Gain Mode	Typ.	Max.	Units
I <sub>DD</sub>	Current consumption	VDD=3.0V	Max 85°C Typ 25°C	Std.	1.5	2	μA
				High	1.9	3	

### 54.13.3 Internal Ultra Low Power 32 kHz RC Oscillator (OSCULP32K) Characteristics

**Table 54-49. Ultra-Low-Power Internal 32 kHz RC Oscillator Electrical Characteristics**

Symbol	Parameter	Calibration	Conditions	Min.	Typ.	Max	Units
F <sub>OUT</sub>	Output frequency	Factory default and without user software calibration	At +25°C , VDDANA = 3.0V	32.10	32.768	33.42	kHz
			[-40, +85]°C, VDDANA>1.71V	27.12	32.768	37.68	
		With user software calibration	Recalibrate using XOSC as reference Clock source	32.28		33.26	
			Recalibrate using DFLL as reference Clock source	31.29		33.75	
Step	Calibration step			-	1.5	-	%F <sub>OUT</sub>
Duty <sup>(1)</sup>	Duty Cycle			-	50	-	%
RuntimeCal	Run-time Calibration		CPU clock on DFLL (48 MHz)	-	-	5	ms

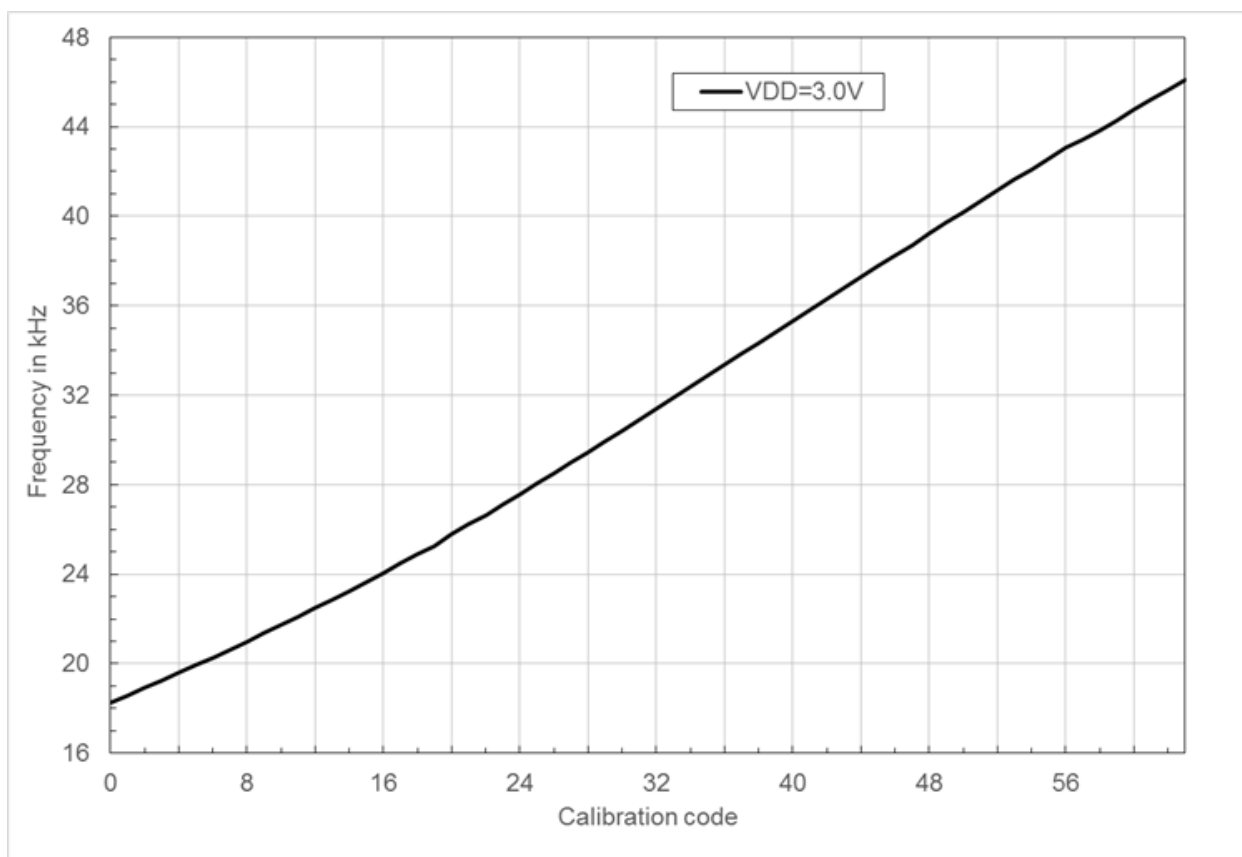
**Note:** These values are based on simulation. They are not covered by production test limits or characterization.



# SAM D5x/E5x Family Data Sheet

Electrical Characteristics at 85°C

Figure 54-8. Average Frequency Versus Calibration Code Value, VDD = 3V



## 54.13.4 Digital Frequency Locked Loop (DFLL48M) Characteristics

Table 54-50. DFLL48M Characteristics - Open Loop Mode <sup>(1)</sup>

Symbol	Parameter	Conditions	Min.	Typ.	Max.	Units
F <sub>OpenOUT</sub>	Output frequency	DFLLVAL after Reset LDO Regulator mode, [-40, 85]°C	45.8	48	49.3	MHz
		DFLLVAL after Reset LDO Regulator mode, [0, 60]°C	47.2	48	48.81	
T <sub>OpenSTARTUP</sub>	Startup time	DFLLVAL after Reset F <sub>OUT</sub> within 90% of final value	-	4.3	7	µs

**Note:**

- DFLL48 in open loop can be used only with LDO regulator.

Table 54-51. DFLL48M Characteristics - Closed Loop Mode

Symbol	Parameter	Conditions	Min.	Typ.	Max.	Units
F <sub>CloseOUT</sub>	Average Output frequency	f <sub>REF</sub> = XTAL, 32.768 kHz, 100 ppm DFLLMUL = 1464	-	47.972	-	MHz
F <sub>REF</sub> <sup>(1,2)</sup>	Input reference frequency	-	732	32768	33000	Hz

# SAM D5x/E5x Family Data Sheet

## Electrical Characteristics at 85°C

.....continued

Symbol	Parameter	Conditions	Min.	Typ.	Max.	Units
$F_{CloseJitter}$	Period Jitter	$f_{REF} = XTAL, 32.768 \text{ kHz}, 100 \text{ ppm}$ $DFLLMUL = 1464$	-	-	0.42	ns
$T_{Lock}$	Lock time	$F_{REF} = XTAL, 32.768 \text{ kHz}, 100 \text{ ppm}$ $DFLLMUL = 1464$ $DFLLVAL$ after Reset $DFLLCTRL.BPLCKC = 1$ $DFLLCTRL.QLDIS = 0$ $DFLLCTRL.CCDIS = 1$ $DFLLMUL.FSTEP = 10$	-	429	1145	$\mu\text{s}$

**Note:**

1. These values are based on simulation. They are not covered by production test limits or characterization.
2. To ensure that the device stays within the maximum allowed clock frequency, any reference clock for the DFLL in close loop must be within 2% error accuracy.

**Table 54-52. DFLL48M Power Consumption**

Symbol	Parameter	Conditions	Ta	Min.	Typ.	Max.	Units
$I_{DD}$	Current Consumption	Open Loop mode - $DFLLVAL$ after reset $VCC = 3.3V$	Max. 85°C Typ. 25°C	-	400	854	$\mu\text{A}$
		Closed Loop mode - $f_{REF} = 32.768 \text{ kHz}$ $VCC = 3.3V$		-	404	851	$\mu\text{A}$

### 54.13.5 Fractional Digital Phase Lock Loop (FDPLL) Characteristics

**Table 54-53. Fractional Digital Phase Lock Loop Characteristics <sup>(2)</sup>**

Symbol	Parameter	Conditions	Min.	Typ.	Max.	Units
$f_{IN}^{(1)}$	Input Frequency		32	-	3200	kHz
$f_{OUT}^{(1)}$	Output Frequency		96	-	200	MHz
$J_p$	Period jitter (Peak-Peak value)	$f_{IN} = 32 \text{ kHz}, f_{OUT} = 96 \text{ MHz}$	-	1.9	2.7	%
		$f_{IN} = 32 \text{ kHz}, f_{OUT} = 200 \text{ MHz}$	-	3.4	4.9	
		$f_{IN} = 3.2 \text{ MHz}, f_{OUT} = 96 \text{ MHz}$	-	2.0	3.0	
		$f_{IN} = 3.2 \text{ MHz}, f_{OUT} = 200 \text{ MHz}$	-	4.3	6.6	
$t_{LOCK}$	Lock Time	After startup, time to get lock signal. $f_{IN} = 3.2 \text{ MHz}$	-	54	95	$\mu\text{s}$
Duty <sup>(1)</sup>	Duty cycle	-	-	50	-	%

**Note:**

1. These values are based on simulation. They are not covered by production test limits or characterization.
2. These FDPLL200M characteristics are applicable with LDO regulator and a direct reference (i.e., REFCLK is XOSC or XOSC32K, not GCLK).

**Table 54-54. Power Consumption**

Symbol	Parameter	Conditions	TA	Typ.	Max.	Units
I <sub>DD</sub>	Current Consumption	Clk = 96 MHz, VDD = 3.3V	Max. 85°C	0.9	1.3	mA
		Clk = 200 MHz, VDD = 3.3V	Typ. 25°C	2	2.3	

### 54.14 Timing Characteristics

#### 54.14.1 External Reset Characteristics

**Table 54-55. External Reset Characteristics<sup>(1)</sup>**

Symbol	Parameter	Min.	Units
t <sub>EXT</sub>	Minimum Reset pulse width	1	μs

**Note:**

1. These values are based on simulation. They are not covered by production test limits or characterization.

**Related Links**

[6.1 Multiplexed Signals](#)

# SAM D5x/E5x Family Data Sheet

Electrical Characteristics at 85°C

## 54.14.2 SERCOM in SPI Mode Timing

Table 54-56. SPI Timing Characteristics and Requirements<sup>(1)</sup>

Symbol	Parameter	Conditions		Min.	Typ.	Max.	Units
t <sub>SCK</sub> <sup>(10)</sup>	SCK period	Master	Reception	2*(t <sub>MIS</sub> + t <sub>SLAVE_OUT</sub> ) <sup>(3)</sup>	-	-	ns
		Master	Transmission	2*(t <sub>MOV</sub> + t <sub>SLAVE_IN</sub> ) <sup>(4)</sup>	-	-	
t <sub>SCKW</sub>	SCK high/low width	Master		-	0.5*t <sub>SCK</sub>	-	
t <sub>SCKR</sub>	SCK rise time <sup>(2)</sup>	Master		-	0.25*t <sub>SCK</sub>	-	
t <sub>SCKF</sub>	SCK fall time <sup>(2)</sup>	Master		-	0.25*t <sub>SCK</sub>	-	
t <sub>MIS</sub>	MISO setup to SCK	Master, VDD>2.70V		18	-	-	
		Master, VDD>1.71V		19	-	-	
t <sub>MIH</sub>	MISO hold after SCK	Master, VDD>2.70V		0	-	-	
		Master, VDD>1.71V		0	-	-	
t <sub>MOV</sub>	MOSI output valid SCK	Master, VDD>2.70V		-	-	9	
		Master, VDD>1.71V		-	-	14	
t <sub>MOH</sub>	MOSI hold after SCK	Master, VDD>2.70V		-	-	-	
		Master, VDD>1.71V		-	-	-	

# SAM D5x/E5x Family Data Sheet

## Electrical Characteristics at 85°C

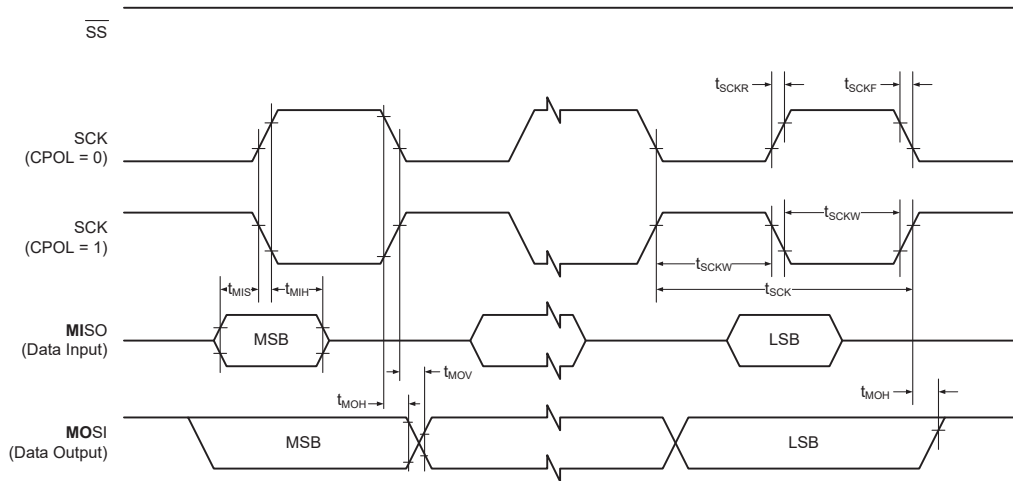
.....continued

Symbol	Parameter	Conditions		Min.	Typ.	Max.	Units
t <sub>SSCK</sub>	Slave SCK Period	Slave	Reception	2*(t <sub>SIS</sub> + t <sub>MASTER_OUT</sub> ) <sup>(5)</sup>	-	-	ns
		Slave	Transmission	2*(t <sub>SOV</sub> + t <sub>MASTER_IN</sub> ) <sup>(6)</sup>	-	-	
t <sub>SSCKW</sub>	SCK high/low width	Slave		-	0.5*t <sub>SSCK</sub>	-	
t <sub>SSCKR</sub>	SCK rise time <sup>(2)</sup>	Slave		-	0.25*t <sub>SSCK</sub>	-	
t <sub>SSCKF</sub>	SCK fall time <sup>(2)</sup>	Slave		-	0.25*t <sub>SSCK</sub>	-	
t <sub>SIS</sub>	MOSI setup to SCK	Slave, VDD>2.70V		7.5	-	-	
		Slave, VDD>1.71V		8.5	-	-	
t <sub>SIH</sub>	MOSI hold after SCK	Slave, VDD>2.70V		4	-	-	
		Slave, VDD>1.71V		4	-	-	
t <sub>SSS</sub>	$\overline{SS}$ setup to SCK	Slave	PRELOADEN=1	t <sub>SOSS</sub> +t <sub>EXT_MIS</sub> + 2*t <sub>APBC</sub> <sup>(8)(9)</sup>	-	-	
			PRELOADEN=0	t <sub>SOSS</sub> +t <sub>EXT_MIS</sub> <sup>(8)</sup>	-	-	
t <sub>SSH</sub>	$\overline{SS}$ hold after SCK	Slave		0.5*t <sub>SSCK</sub>	-	-	
t <sub>SOV</sub>	MISO output valid SCK	Slave, VDD>2.70V		15	-	-	
		Slave, VDD>1.71V		24	-	-	
t <sub>SOH</sub>	MISO hold after SCK	Slave, VDD>2.70V		0	-	-	
		Slave, VDD>1.71V		0	-	-	
t <sub>SOSS</sub>	MISO setup after $\overline{SS}$ low	Slave, VDD>2.70V		-	-	1* t <sub>SCK</sub>	
		Slave, VDD>1.71V		-	-	1* t <sub>SCK</sub>	

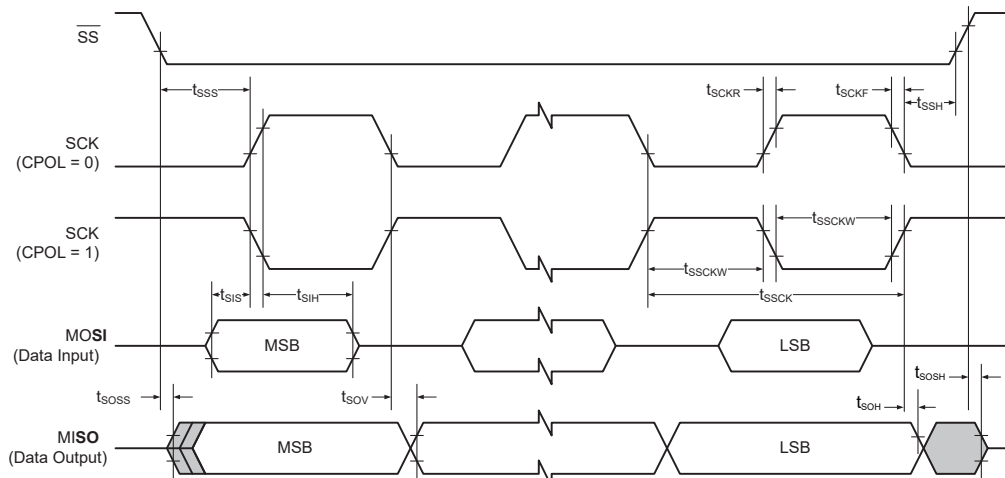
1. These values are based on simulation, with capacitance load between 5pF and 20pF. These values are not covered by test limits in production.
2. See I/O Pin Characteristics.
3. Where t<sub>SLAVE\_OUT</sub> is the slave external device output response time, generally t<sub>EXT\_SOV</sub>+t<sub>LINE\_DELAY</sub><sup>(7)</sup>.
4. Where t<sub>SLAVE\_IN</sub> is the slave external device input constraint, generally t<sub>EXT\_SIS</sub>+t<sub>LINE\_DELAY</sub><sup>(7)</sup>.
5. Where t<sub>MASTER\_OUT</sub> is the master external device output response time, generally t<sub>EXT\_MOV</sub> + t<sub>LINE\_DELAY</sub><sup>(7)</sup>.
6. Where t<sub>MASTER\_IN</sub> is the master external device input constraint, generally t<sub>EXT\_MIS</sub>+t<sub>LINE\_DELAY</sub><sup>(7)</sup>.
7. t<sub>LINE\_DELAY</sub> is the transmission line time delay.
8. t<sub>EXT\_MIS</sub> is the input constraint for the master external device.
9. t<sub>APBC</sub> is the APB period for SERCOM.
10. When the integrity of communication is required to maintain both transmission and reception, the maximum SPI clock frequency should be the lower value of the reception or transmission mode maximum frequency as shown in the following equations.

- Reception:  $t_{SCK} = 2 * (t_{MIS} + t_{SLAVE\_OUT}) = 2 * (18 + 8) = 52nS$
- Transmission:  $t_{SCK} = 2 * (t_{MOV} + t_{SLAVE\_IN}) = 2 * (9 + 20) = 58nS$

**Figure 54-9. SPI Timing Requirements in Master Mode**

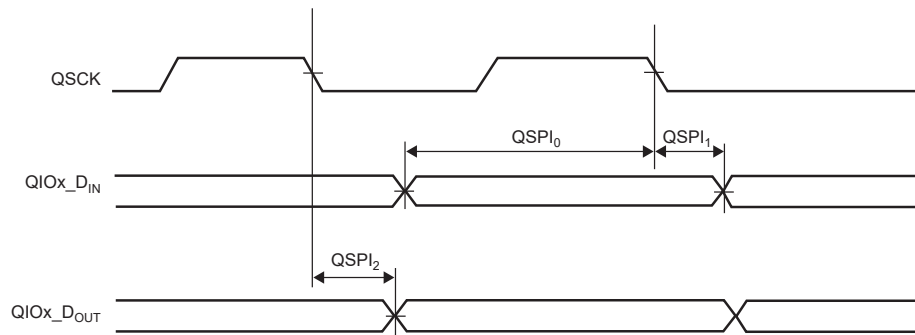


**Figure 54-10. SPI Timing Requirements in Slave Mode**

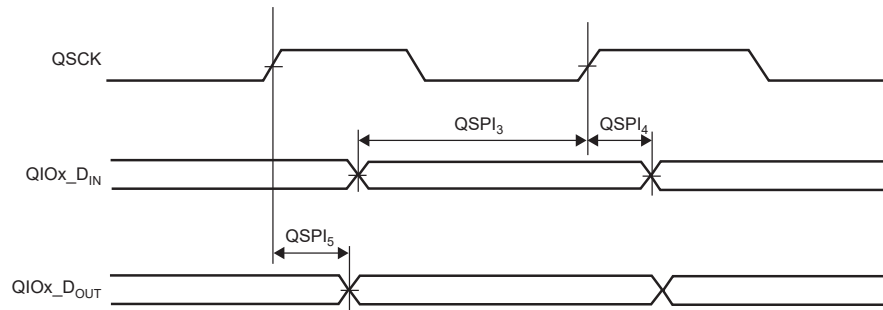


### 54.14.3 QSPI Characteristics

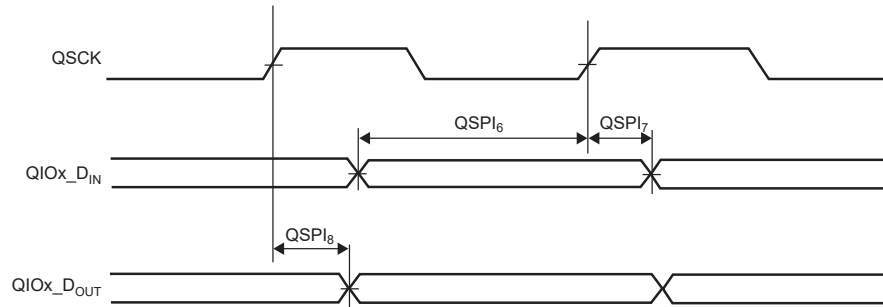
**Figure 54-11. QSPI SDR Master Mode 0**



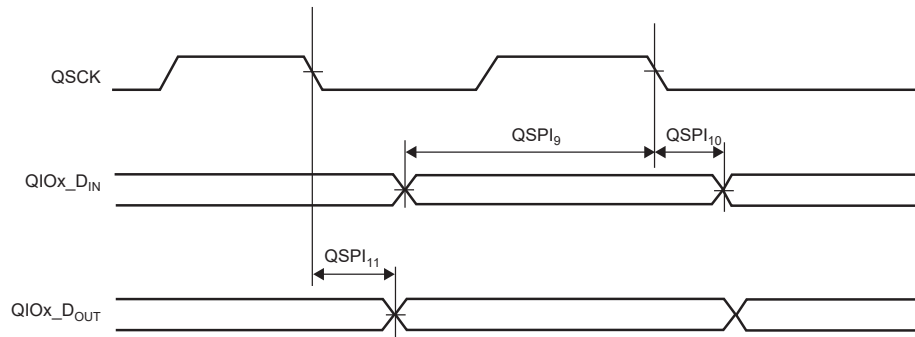
**Figure 54-12. QSPI SDR Master Mode 1**



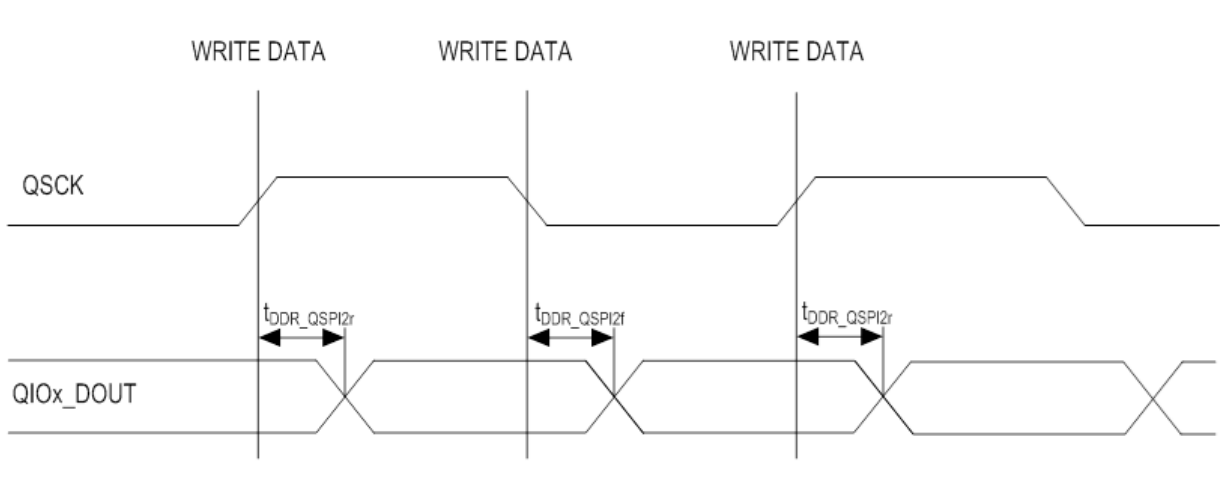
**Figure 54-13. QSPI SDR Master Mode 2**



**Figure 54-14. QSPI SDR Master Mode 3**



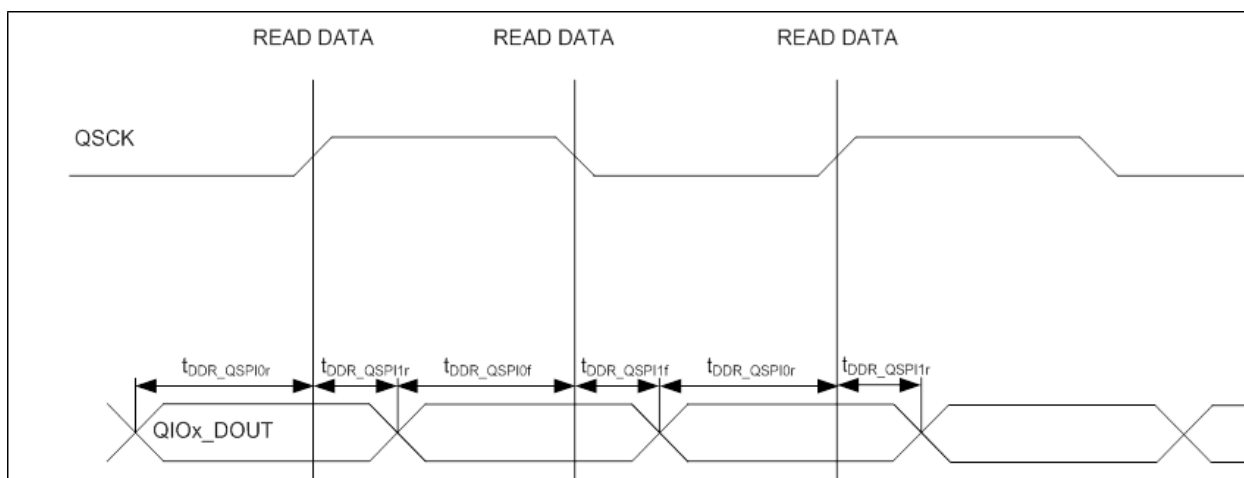
**Figure 54-15. QSPI DDR Mode 0 READ**



# SAM D5x/E5x Family Data Sheet

## Electrical Characteristics at 85°C

**Figure 54-16. QSPI DDR Mode 0 WRITE**



**Table 54-57. QSPI Timing Characteristics (see Note 1)**

Name	Description	Mode	V <sub>DD</sub> = 1.8V			V <sub>DD</sub> = 3.3V			Units
			Min.	Typ.	Max.	Min.	Typ.	Max.	
f <sub>SDR_m0_m2</sub>	QSPI SDR Frequency	Master SDR Mode 0/2	-	-	50.0	-	-	75	MHz
f <sub>SDR_m1_m3</sub>	QSPI SDR Frequency	Master SDR Mode 1/3	-	-	50.0	-	-	50	
f <sub>DDR</sub>	QSPI DDR Frequency	Master mode	-	-	37.5	-	-	66	
t <sub>SDR_QSPI0</sub>	Input Setup Time	Master SDR mode 0	3.86	-	-	3.85	-	-	ns
t <sub>SDR_QSPI1</sub>	Input Hold Time	Master SDR mode 0	0.00	-	-	0.19	-	-	
t <sub>SDR_QSPI2</sub>	Data Out Valid Time	Master SDR mode 0	-	-	3.33	-	-	2.67	
t <sub>SDR_QSPI3</sub>	Input Setup Time	Master SDR mode 1	3.79	-	-	3.59	-	-	ns
t <sub>SDR_QSPI4</sub>	Input Hold Time	Master SDR mode 1	0.06	-	-	0.19	-	-	
t <sub>SDR_QSPI5</sub>	Data Out Valid Time	Master SDR mode 1	-	-	2.71	-	-	2.71	
t <sub>SDR_QSPI6</sub>	Input Setup Time	Master SDR mode 2	3.79	-	-	3.58	-	-	ns
t <sub>SDR_QSPI7</sub>	Input Hold Time	Master SDR mode 2	0.06	-	-	0.19	-	-	
t <sub>SDR_QSPI8</sub>	Data Out Valid Time	Master SDR mode 2	-	-	2.74	-	-	2.65	
t <sub>SDR_QSPI9</sub>	Input Setup Time	Master SDR mode 3	3.86	-	-	3.86	-	-	ns
t <sub>SDR_QSPI10</sub>	Input Hold Time	Master SDR mode 3	-0.10	-	-	0.19	-	-	
t <sub>SDR_QSPI11</sub>	Data Out Valid Time	Master SDR mode 3	-	-	3.22	-	-	2.60	



# SAM D5x/E5x Family Data Sheet

## Electrical Characteristics at 85°C

.....continued

Name	Description	Mode	V <sub>DD</sub> = 1.8V			V <sub>DD</sub> = 3.3V			Units
			Min.	Typ.	Max.	Min.	Typ.	Max.	
t <sub>DDR_QSPI0f</sub>	Input Setup Time	Master DDR mode 0 fall edge	3.87	-	-	3.85	-	-	ns
t <sub>DDR_QSPI1f</sub>	Input Hold Time	Master DDR mode 0 fall edge	0.00	-	-	0.19	-	-	
t <sub>DDR_QSPI2f</sub>	Data Out Valid Time	Master DDR mode 0 fall edge	-	-	2.1	-	-	2.03	
t <sub>DDR_QSPI0r</sub>	Input Setup Time	Master DDR mode 0 rise edge	3.81	-	-	3.57	-	-	
t <sub>DDR_QSPI1r</sub>	Input Hold Time	Master DDR mode 0 rise edge	0.06	-	-	0.19	-	-	
t <sub>DDR_QSPI2r</sub>	Data Out Valid Time	Master DDR mode 0 rise edge	-	-	3.13	-	-	2.12	

**Note:**

1. These values are based on simulation. They are not covered by production test limits or characterization.
2. All timing characteristics are given for 20pF capacitive load.

**Table 54-58. QSPI Maximum Frequency examples<sup>(1)</sup>**

QSPI Mode	CLK_QSPI2 X_AHB	CLK_QSPI_AHB	Max. CPU_CLK	Max. QSPI Speed	Conditions
SDR	X	120 MHz	120 MHz	60 MHz	BAUD -> BAUD[7:0] must be greater than 0 to ensure QSPI clock frequency is as per electrical specifications provided in <a href="#">table 54-52</a> .
	X	75 MHz	75 MHz	75 MHz	-
DDR	132 MHz	66 MHz	66 MHz	66 MHz	-

**Note:** 1. Examples shown do not supersede the electrical specifications shown in [Table 54-52. QSPI Timing Characteristics](#).

### 54.14.4 GMAC Characteristics

#### Timing Conditions

**Table 54-59. GMAC Load Capacitance on Data, Clock Pads**

Symbol	Description	Condition	Min.	Max.	Units
$C_L$	Load Capacitance	$V_{DD}=3.3V$	0	20	pF

#### Timing Constraints

The GMAC must be constrained so as to satisfy the timings of standards given the following two tables, in MAX corner.

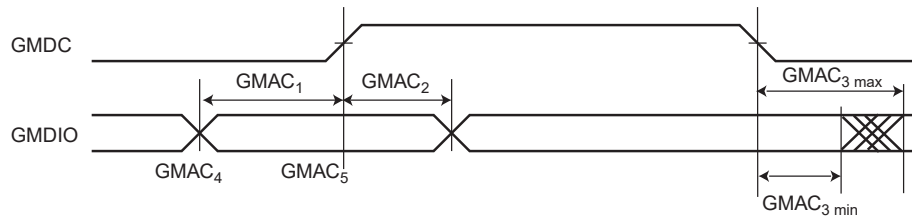
**Table 54-60. Minimum and Maximum Access Time of GMAC Output Signals**

Symbol	Parameter	Min.	Max.	Units
GMAC <sub>1</sub>	Setup for GMDIO from GMDC rising	10	-	ns
GMAC <sub>2</sub>	Hold for GMDIO from GMDC rising	10	-	
GMAC <sub>3</sub>	GMDIO toggling from GMDC falling	0 <sup>(1)</sup>	10 <sup>(1)</sup>	

#### Note:

- For GMAC output signals, min. and max. access times are defined:
  - The min. access time is the time between the GMDC falling edge and the signal change.
  - The max. access time is the time between the GMDC falling edge and the signal stabilizes.

**Figure 54-17. Minimum and Maximum Access Time of GMAC Output Signals**



# SAM D5x/E5x Family Data Sheet

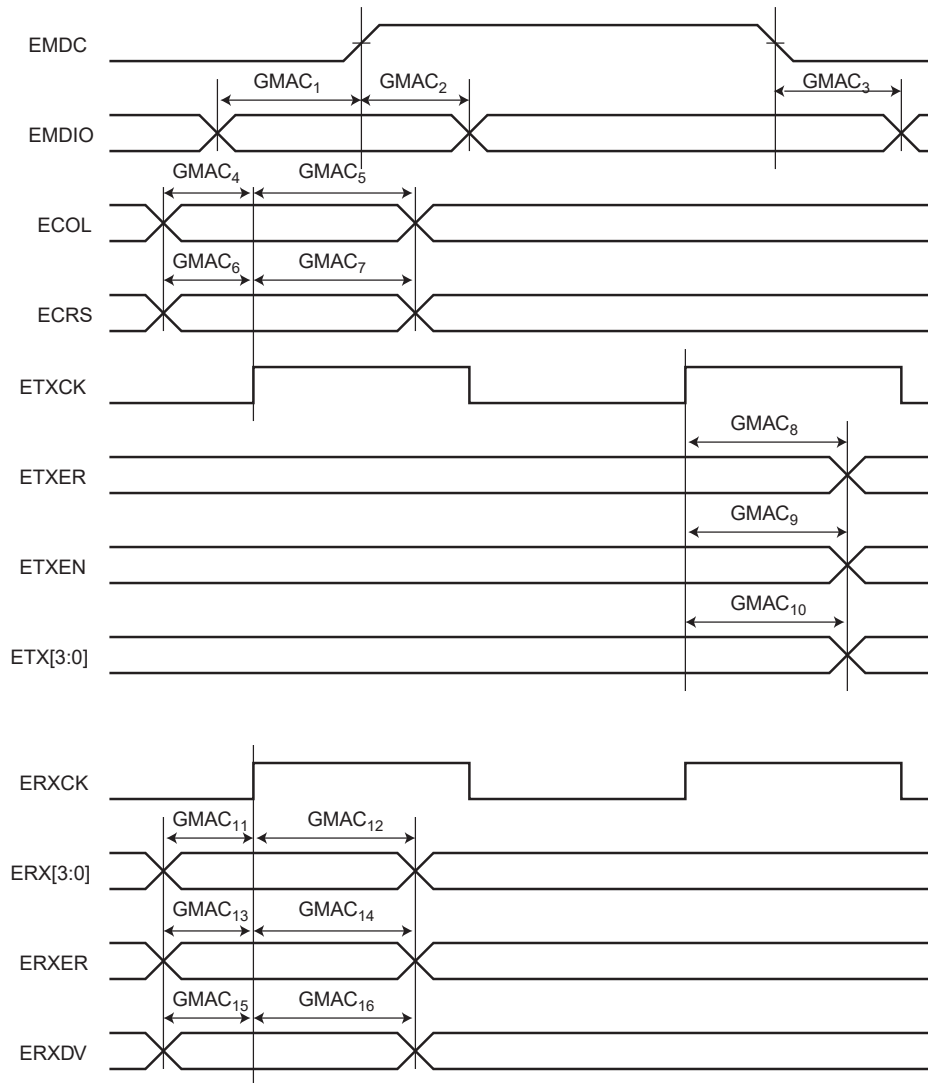
Electrical Characteristics at 85°C

## MII Mode

Table 54-61. GMAC MII Mode Timings

Symbol	Parameter	Min	Max	Unit
GMAC <sub>4</sub>	Setup for GCOL from GTXCK rising	10	–	ns
GMAC <sub>5</sub>	Hold for GCOL from GTXCK rising	10	–	
GMAC <sub>6</sub>	Setup for GCRS from GTXCK rising	10	–	
GMAC <sub>7</sub>	Hold for GCRS from GTXCK rising	10	–	
GMAC <sub>8</sub>	GTXER toggling from GTXCK rising	10	25	
GMAC <sub>9</sub>	GTXEN toggling from GTXCK rising	10	25	
GMAC <sub>10</sub>	GTX toggling from GTXCK rising	10	25	
GMAC <sub>11</sub>	Setup for GRX from GRXCK	10	–	
GMAC <sub>12</sub>	Hold for GRX from GRXCK	10	–	
GMAC <sub>13</sub>	Setup for GRXER from GRXCK	10	–	
GMAC <sub>14</sub>	Hold for GRXER from GRXCK	10	–	
GMAC <sub>15</sub>	Setup for GRXDV from GRXCK	10	–	
GMAC <sub>16</sub>	Hold for GRXDV from GRXCK	10	–	

**Figure 54-18. GMAC MII Mode Signals**



# SAM D5x/E5x Family Data Sheet

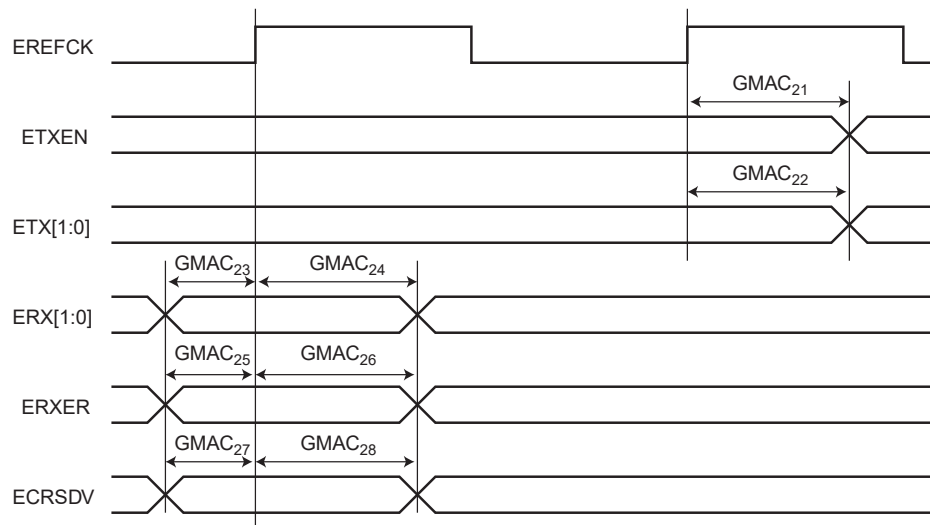
Electrical Characteristics at 85°C

## RMII Mode

Table 54-62. GMAC RMII Mode Timings

Symbol	Parameter	Min.	Max.	Units
GMAC <sub>21</sub>	ETXEN toggling from EREFCK rising	2	16	ns
GMAC <sub>22</sub>	ETX toggling from EREFCK rising	2	16	
GMAC <sub>23</sub>	Setup for ERX from EREFCK rising	4	-	
GMAC <sub>24</sub>	Hold for ERX from EREFCK rising	2	-	
GMAC <sub>25</sub>	Setup for ERXER from EREFCK rising	4	-	
GMAC <sub>26</sub>	Hold for ERXER from EREFCK rising	2	-	
GMAC <sub>27</sub>	Setup for ECRSDV from EREFCK rising	4	-	
GMAC <sub>28</sub>	Hold for ECRSDV from EREFCK rising	2	-	

Figure 54-19. GMAC RMII Mode Signals



# SAM D5x/E5x Family Data Sheet

Electrical Characteristics at 85°C

## 54.14.5 I<sup>2</sup>S Characteristics

Table 54-63. I<sup>2</sup>S Timing Characteristics and Requirements (see Note 1)

Name	Description	Mode	VDD = 1.8V			VDD = 3.3V			Units
			Min.	Typ.	Max.	Min.	Typ.	Max.	
t <sub>M_MCKOR</sub>	I2S MCK rise time <sup>(2)</sup>	Master mode / Capacitive load CL = 20 pF	-	-	5.41	-	-	2.68	ns
t <sub>M_MCKOF</sub>	I2S MCK fall time <sup>(2)</sup>	Master mode / Capacitive load CL = 20 pF	-	-	5.84	-	-	2.81	ns
d <sub>M_MCKO</sub>	I2S MCK duty cycle	Master mode	-	50.0	-	-	50.0	-	%
d <sub>M_MCKI</sub>	I2S MCK duty cycle	Master mode, pin is input (1b)	-	50.0	-	-	50.0	-	%
t <sub>M_SCKOR</sub>	I2S SCK rise time <sup>(2)</sup>	Master mode / Capacitive load CL = 20 pF	-	-	5.06	-	-	2.51	ns
t <sub>M_SCKOF</sub>	I2S SCK fall time <sup>(2)</sup>	Master mode / Capacitive load CL = 20 pF	-	-	5.46	-	-	2.64	ns
d <sub>M_SCKO</sub>	I2S SCK duty cycle	Master mode	-	50.0	-	-	50.0	-	%
f <sub>M_SCKO</sub> 1/t <sub>M_SCKO</sub>	I2S SCK frequency	Master mode Supposing external device response delay is 0ns	-	-	32.07	-	-	43.73	MHz
		Master mode Supposing external device response delay is 30ns	-	-	10.97	-	-	12.07	MHz
f <sub>S_SCKI</sub> 1/t <sub>S_SCKI</sub>	I2S SCK frequency	Slave mode Supposing external device response delay is 30ns	-	-	15.63	-	-	15.87	MHz
d <sub>S_SCKO</sub>	I2S SCK duty cycle	Slave mode	-	50.0	-	-	50.0	-	%
t <sub>M_FSOV</sub>	FS valid time	Master mode	-	-	5.4	-	-	4.2	ns
t <sub>M_FSOH</sub>	FS hold time	Master mode	-0.3	-	-	-0.3	-	-	ns
t <sub>S_FSiS</sub>	FS setup time	Slave mode	7.8	-	-	7.5	-	-	ns
t <sub>S_FSiH</sub>	FS hold time	Slave mode	0.0	-	-	0.0	-	-	ns
t <sub>M_SDIS</sub>	Data input setup time	Master mode	15.8	-	-	11.6	-	-	ns
t <sub>M_SDIH</sub>	Data input hold time	Master mode	3.4	-	-	3.4	-	-	ns
t <sub>S_SDIS</sub>	Data input setup time	Slave mode	2.4	-	-	1.9	-	-	ns

# SAM D5x/E5x Family Data Sheet

## Electrical Characteristics at 85°C

.....continued

Name	Description	Mode	VDD = 1.8V			VDD = 3.3V			Units
			Min.	Typ.	Max.	Min.	Typ.	Max.	
t <sub>S_SDIH</sub>	Data input hold time	Slave mode	-1.1	-	-	-1.0	-	-	ns
t <sub>M_SDOV</sub>	Data output valid time	Master transmitter	-	-	3.7	-	-	3.0	ns
t <sub>M_SDOH</sub>	Data output hold time	Master transmitter	-0.5	-	-	-0.5	-	-	ns
t <sub>S_SDOV</sub>	Data output valid time	Slave transmitter	-	-	16.4	-	-	12.1	ns
t <sub>S_SDOH</sub>	Data output hold time	Slave transmitter	4.1	-	-	4.1	-	-	ns
t <sub>PDM2LS</sub>	Data input setup time	Master mode PDM2 Left	15.8	-	-	11.6	-	-	ns
t <sub>PDM2LH</sub>	Data input hold time	Master mode PDM2 Left	3.4	-	-	3.4	-	-	ns
t <sub>PDM2RS</sub>	Data input setup time	Master mode PDM2 Right	15.1	-	-	11.6	-	-	ns
t <sub>PDM2RH</sub>	Data input hold time	Master mode PDM2 Right	3.4	-	-	3.4	-	-	ns

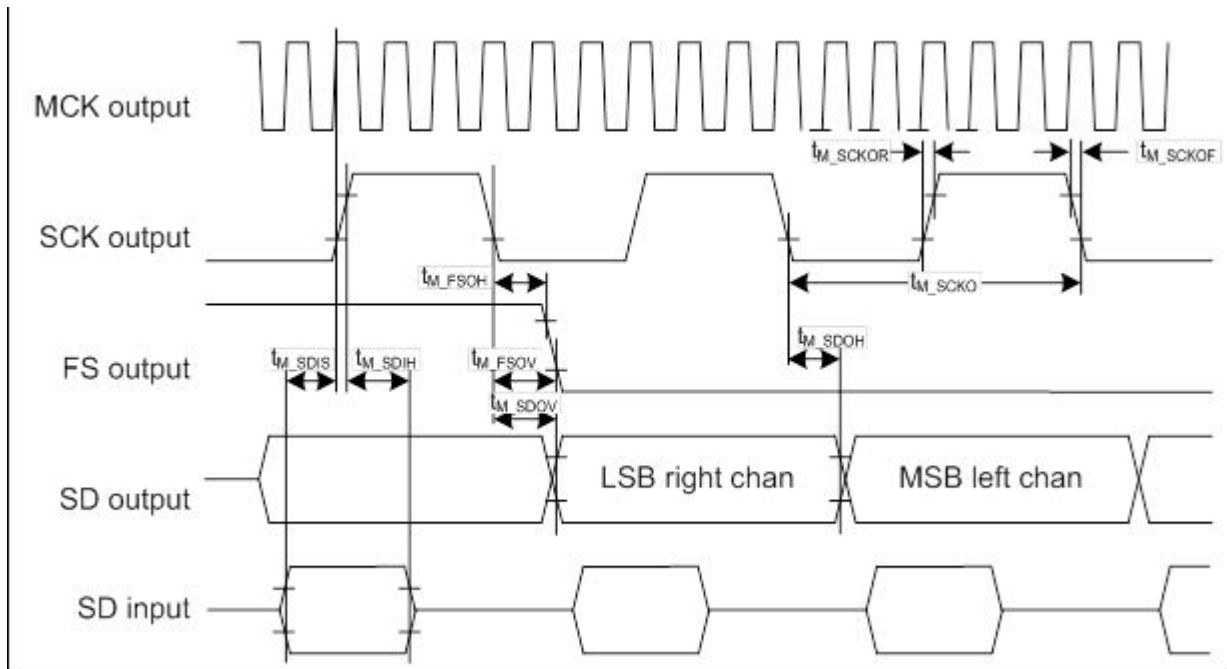


**Notice:** All timing values are given for 20pF capacitive load.

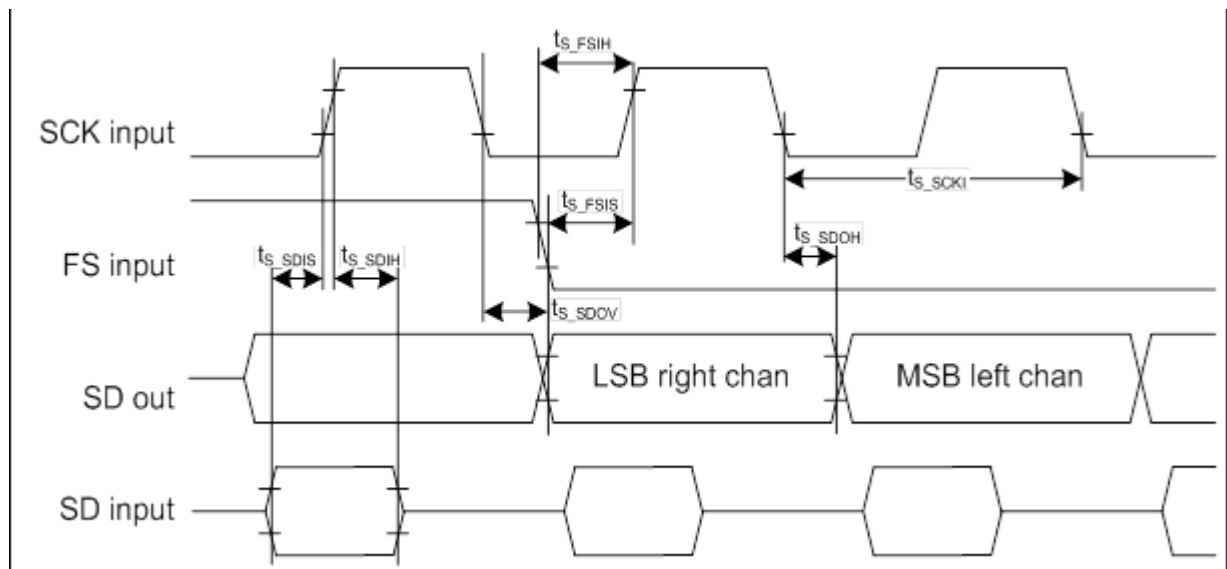
### Note:

1. These values are based on simulation. They are not covered by production test limits or characterization.
2. See I/O Pin Characteristics.

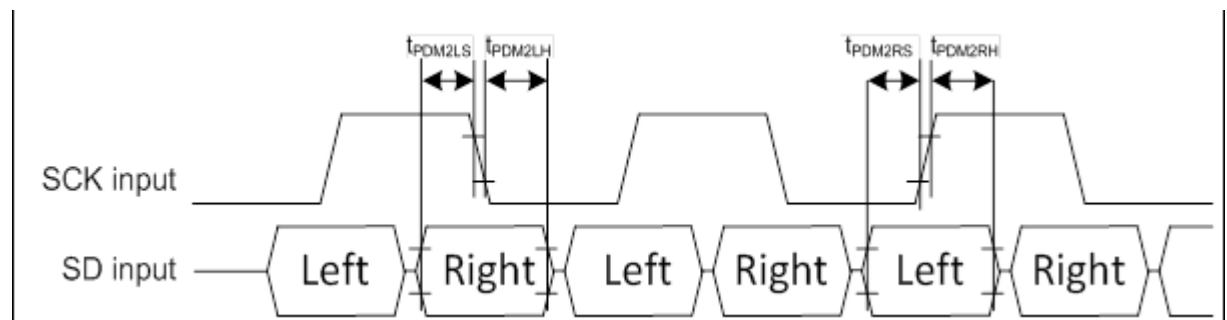
**Figure 54-20. Master Mode: SCK, FX, and MCK are Output**



**Figure 54-21. Slave Mode: SCK and FS are Input**



**Figure 54-22. PDM2 Mode**





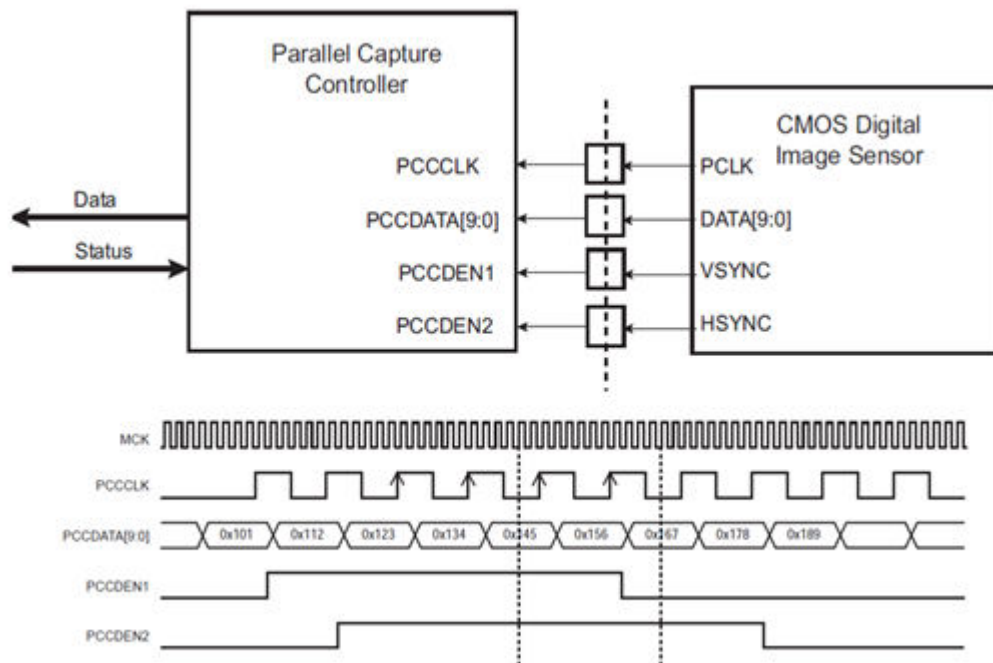
### 54.14.6 PCC Characteristics

Speed requirements for all 8/10/12/14-bits are:

- pclk: 48 MHz at 3.3V
- pclk: 28 MHz at 1.8V

APB clock minimum is  $2 \times N$  pclk

**Figure 54-23. PCC Signaling**



### 54.15 USB Characteristics

The USB on-chip buffers comply with the Universal Serial Bus (USB) v2.0 standard. All AC parameters related to these buffers can be found within the USB 2.0 electrical specifications.

The USB interface is USB-IF certified:

- TID 40001782 - Peripheral Silicon > Low/Full Speed > Silicon Building Blocks
- TID 120000724 - Embedded Hosts > Full Speed

Electrical configuration required to be USB-compliant:

- the CPU frequency must be higher than 16 MHz when USB is active (No constraint for USB suspend mode)
- the operating voltages must be 3.3V (Min. 3.0V, Max. 3.6V).
- the GCLK\_USB frequency accuracy source must be less than:
  - in USB device mode, 48MHz +/-0.25%
  - in USB host mode, 48MHz +/-0.05%

# SAM D5x/E5x Family Data Sheet

Electrical Characteristics at 85°C

**Table 54-64. GCLK\_USB Clock Setup Recommendations**

Clock setup		USB Device	USB Host
DFLL48M	Open loop	No	No
	Close loop, Ref. internal OSC source	No	No
	Close loop, Ref. external XOSC source	<b>Yes</b>	No
	Close loop, Ref. SOF (USB recovery mode) <sup>(1)</sup>	<b>Yes</b> <sup>(2)</sup>	N/A
FDPLL	internal OSC (32K, 8M...)	No	No
	external OSC (<1MHz)	<b>Yes</b>	No
	external OSC (>1MHz)	<b>Yes</b> <sup>(3)</sup>	<b>Yes</b>

**Note:**

1. When using DFLL48M in USB recovery mode, the Fine Step value must be 0xA to guarantee a USB clock at +/-0.25% before 11ms after a resume. Only usable in LDO regulator mode.
2. Very high signal quality and crystal-less. It is the best setup for USB Device mode.
3. FDPLL lock time is short when the clock frequency source is high (> 1 MHz). Thus, FDPLL and external OSC can be stopped during USB suspend mode to reduce consumption and guarantee a USB wake-up time (See TDRSMDN in the USB 2.0 specification).

### 55. Electrical Characteristics at 105°C

The specifications for 105°C temperature devices are identical to those shown in 54. [Electrical Characteristics at 85°C](#), with the exception of the parameters listed in this chapter.

#### 55.1 General Operating Ratings (105°C)

The device must operate within the ratings listed below in order for all other electrical characteristics and typical characteristics of the device to be valid.

**Table 55-1. General Operating Conditions**

Symbol	Description	Min.	Typ.	Max.	Units
T <sub>A</sub>	Temperature range	-40	25	105	°C
T <sub>J</sub>	Junction temperature	-	-	125	°C

#### 55.2 Supply Characteristics (105°C)

**Table 55-2. Power Supply Current Requirement**

Symbol	Conditions	Current	Units
		Max	
I <sub>input</sub>	Power-up Maximum Current	10	mA

**Note:** I<sub>input</sub> is the minimum requirement for the power supply connected to the device.

#### 55.3 Power Consumption (105°C)

The values in this section are measured values of power consumption under the following conditions, except where noted:

- **Operating Conditions**
  - CPU is running on Flash with automatic wait state
  - Low power cache enabled
  - BOD33 is disabled
  - I/Os are inactive input mode, with input trigger disabled
- **Oscillators**
  - XOSC0 (crystal oscillator) running with external 32 MHz crystal
  - XOSC32K (32 kHz crystal oscillator) running with external 32 kHz crystal in LP mode
  - FDPLL is using XOSC32K as reference on LDO and external clock 32768 on Buck mode
  - DFLL48M is using XOSC32K as reference

# SAM D5x/E5x Family Data Sheet

## Electrical Characteristics at 105°C

**Table 55-3. Active Current Consumption - Active Mode**

Mode	conditions	Regulator	Clock	VDD	T <sub>A</sub>	Typ.	Max	Units
ACTIVE	COREMARK <sup>(1)</sup>	LDO	FDPLL 120MHz	1.8	Max at 105°C Typ at 25°C	136	191	uA/Mhz
				3.3		137	193	
			DFLL 48MHz	1.8		136	271	
				3.3		136	272	
			XOSC 32MHz	1.8		146	346	
				3.3		149	347	
		BUCK	FDPLL 120MHz	1.8		103	151	
				3.3		65	133	
			DFLL 48MHz	1.8		102	225	
				3.3		63	169	
			XOSC 32MHz	1.8		110	283	
				3.3		73	224	
IDLE	NA	LDO	FDPLL 120MHz	1.8	21	78		
				3.3	23	81		
			DFLL 48MHz	1.8	21	156		
				3.3	21	156		
			XOSC 32MHz	1.8	25	231		
				3.3	27	233		
		BUCK	FDPLL 120MHz	1.8	16	59		
				3.3	11	54		
			DFLL 48MHz	1.8	16	119		
				3.3	10	85		
			XOSC 32MHz	1.8	21	180		
				3.3	19	135		

**Note:**

- System Configuration used:
  - MCLK all APB clocks masked except MCLK and NVMCTRL
  - MCLK.AHBMASK = 0x00C00FFF
  - CMCC enabled

# SAM D5x/E5x Family Data Sheet

## Electrical Characteristics at 105°C

**Table 55-4. Standby, Hibernate, Backup and OFF Mode Current Consumption**

Mode	Conditions	Regulator Mode	V <sub>CC</sub>	T <sub>A</sub>	Typ.	Max.	Units
STANDBY	fast wake-up disabled (PM.STDBYCFG.FASTWKUP=0x0), no peripheral running	LDO	1.8V	Max at 105°C Typ at 25°C	43	3316	μA
			3.3V		43	3322	
	No System RAM retained (PM.STDBYCFG.RAMCFG=0x2). 8KB backup RAM retained	BUCK	1.8V		26	2211	
			3.3V		17	1581	
	fast wake-up enabled (PM.STDBYCFG.FASTWKUP=0x3), no peripheral running	LDO	1.8V		85	5106	
			3.3V		85	5110	
	No System RAM retained (PM.STDBYCFG.RAMCFG=0x2). 8KB backup RAM retained	BUCK	1.8V		65	3907	
			3.3V		47	2756	
	fast wake-up disabled (PM.STDBYCFG.FASTWKUP=0x0), RTC running on XOSC32K	LDO	1.8V		43	3322	
			3.3V		44	3329	
	No System RAM retained (PM.STDBYCFG.RAMCFG=0x2). 8KB backup RAM retained	BUCK	1.8V		26	2218	
			3.3V		18	1587	
	fast wake-up disabled (PM.STDBYCFG.FASTWKUP=0x0), RTC running on XOSC32K 32KB	LDO	1.8V		45	3462	
			3.3V		46	3469	
	System RAM retained (PM.STDBYCFG.RAMCFG=0x1). 8KB backup RAM retained	BUCK	1.8V		27	2311	
			3.3V		19	1652	
	fast wake-up disabled (PM.STDBYCFG.FASTWKUP=0x0), RTC running on XOSC32K	LDO	1.8V		53	3997	
			3.3V		53	4003	
	Full System RAM retained (PM.STDBYCFG.RAMCFG=0x0). 8KB backup RAM retained	BUCK	1.8V		32	2668	
			3.3V		22	1903	
	fast wake-up enabled (PM.STDBYCFG.FASTWKUP=0x3), no peripheral running	LDO	1.8V		101	3126	
			3.3V		101	3140	
	Full System RAM retained (PM.STDBYCFG.RAMCFG=0x0). 8KB backup RAM retained	BUCK	1.8V		78	2375	
			3.3V		55	1659	
fast wake-up enabled (PM.STDBYCFG.FASTWKUP=0x3), RTC running on XOSC32K	LDO	1.8V	102	3132			
		3.3V	103	3146			
Full System RAM retained (PM.STDBYCFG.RAMCFG=0x0). 8KB backup RAM retained	BUCK	1.8V	79	2383			
		3.3V	56	1666			

# SAM D5x/E5x Family Data Sheet

## Electrical Characteristics at 105°C

.....continued							
Mode	Conditions	Regulator Mode	V <sub>CC</sub>	T <sub>A</sub>	Typ.	Max.	Units
HIBERNATE	no peripheral running No System RAM retained (PM.HIBCFG.RAMCFG=0x2) No backup RAM retained (PM.HIBCFG.BRAMCFG=0x2)	LDO	1.8V	Max at 105°C Typ at 25°C	6	168	μA
			3.3V		6	170	
		BUCK	1.8V		3	111	
			3.3V		3	111	
	RTC is running on XOSC32K No System RAM retained (PM.HIBCFG.RAMCFG=0x2) No backup RAM retained (PM.HIBCFG.BRAMCFG=0x2)	LDO	1.8V		6	169	
			3.3V		7	172	
		BUCK	1.8V		3	113	
			3.3V		3	112	
	RTC is running on XOSC32K No System RAM retained (PM.HIBCFG.RAMCFG=0x2) 4KB backup RAM retained (PM.HIBCFG.BRAMCFG=0x1)	LDO	1.8V		7	193	
			3.3V		8	196	
		BUCK	1.8V		3	129	
			3.3V		4	128	
	RTC is running on XOSC32K No System RAM retained (PM.HIBCFG.RAMCFG=0x2) 8KB backup RAM retained (PM.HIBCFG.BRAMCFG=0x0)	LDO	1.8V		7	217	
			3.3V		8	219	
		BUCK	1.8V		4	144	
			3.3V		4	143	
	RTC is running on XOSC32K 32KB System RAM retained (PM.HIBCFG.RAMCFG=0x1) 8KB backup RAM retained (PM.HIBCFG.BRAMCFG=0x0)	LDO	1.8V		9	350	
			3.3V		10	352	
		BUCK	1.8V		5	233	
			3.3V		4	228	
	RTC is running on XOSC32K Full System RAM retained (PM.HIBCFG.RAMCFG=0x0) 8KB backup RAM retained (PM.HIBCFG.BRAMCFG=0x0)	LDO	1.8V		16	873	
			3.3V		17	874	
		BUCK	1.8V		9	580	
			3.3V		7	431	
BACKUP	powered by VDDIO, no RTC running VDDIO+VDDANA consumption No backup RAM retained (PM.BKUPCFG.BRAMCFG=0x2)	BUCK	1.8V	Max at 105°C Typ at 25°C	2.1	160	μA
			3.3V		2.5	162	
	powered by VDDIO with RTC running on XOSC32K VDDIO+VDDANA consumption No backup RAM retained (PM.BKUPCFG.BRAMCFG=0x2)		1.8V		2.7	161	
			3.3V		3.3	164	
	powered by VDDIO, no RTC running VDDIO+VDDANA consumption 4KB backup RAM retained (PM.BKUPCFG.BRAMCFG=0x1)		1.8V		2.4	183	
			3.3V		2.8	185	
	powered by VDDIO, no RTC running VDDIO+VDDANA consumption 8KB backup RAM retained (PM.BKUPCFG.BRAMCFG=0x0)		1.8V		2.7	207	
			3.3V		3.1	209	
	Battery Backup mode powered by VBAT with RTC running on		1.8V		2.7	161	
			3.3V		3.3	164	
OFF	-	1.8V	0.191	11	μA		
		3.3V	0.331	13			

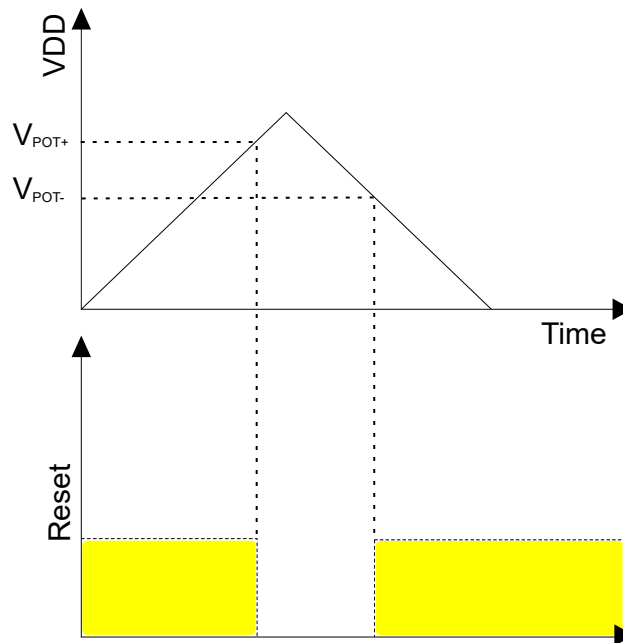
### 55.4 Analog Characteristics (105°C)

#### 55.4.1 Power-On Reset (POR) Characteristics (105°C)

Table 55-5. POR Characteristics

Symbol	Parameters	Min.	Typ.	Max.	Unit
$V_{POT+}$	Voltage threshold Level on $V_{DDIO}$ rising	1.52	1.58	1.65	V
$V_{POT-}$	Voltage threshold Level on $V_{DDIO}$ falling	0.97	1.26	1.36	V

Figure 55-1. POR Operating Principle



**Note:** The shaded area indicates that the device is in a Reset state.

#### 55.4.2 Brown-Out Detectors (BOD) Characteristics (105°C)

Figure 55-2. BOD33 Hysteresis OFF

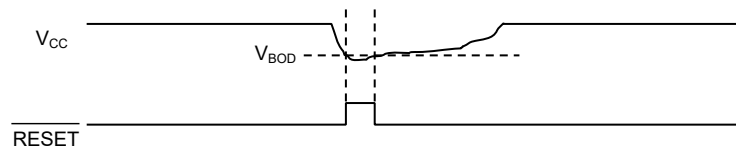
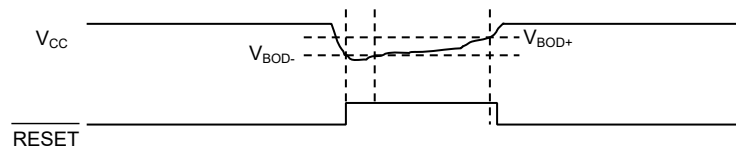


Figure 55-3. BOD33 Hysteresis ON



# SAM D5x/E5x Family Data Sheet

Electrical Characteristics at 105°C

**Table 55-6. BOD33 Characteristics on V<sub>DD</sub> and V<sub>BAT</sub> Monitoring in Normal Mode (During Power-up Phase and Active Mode)**

Symbol	Parameters	Conditions <sup>(3, 4)</sup>	Min	Typ	Max	Unit
VBOD or VBOD- <sup>(1)</sup>	BOD33 threshold level Hysteresis OFF or BOD33 threshold level Hysteresis ON	LEVEL[7:0] = 0x00 (min)	1.453	1.509	1.554	V
		LEVEL[7:0] = 0x19 (recommended value)	1.598	1.658	1.708	
		LEVEL[7:0] = 0x1C (fuse value)	1.616	1.676	1.726	
		LEVEL[7:0] = 0xFF (max)	2.925	3.040	3.133	
VBOD+ <sup>(2)</sup>	BOD33 threshold level Hysteresis ON at power voltage rising	LEVEL[7:0] = 0x00 (min)	1.463	1.520	1.565	
		LEVEL[7:0] = 0x19 (recommended value)	1.607	1.669	1.719	
		LEVEL[7:0] = 0x1C (fuse value)	1.625	1.687	1.737	
		LEVEL[7:0] = 0xFF (max)	2.932	3.041	3.316	

**Note:**

1.  $VBOD = VBOD- = 1.5 + LEVEL[7:0] * Level\_Step$  LEVEL[7:0] is calibration setting bus of threshold level.
2.  $VBOD+ = VBOD- + N * HYST\_STEP$  N = 0 to 15 according to HYST[3:0] value HYST\_STEP = Level\_Step.
3. Hysteresis OFF mode, HYST[3:0] = 0x0.
4. Hysteresis ON mode, HYST[3:0] = 0x1 to 0xf; Min/Typ/Max values given for 0x2.
5. At the upper side of LEVEL[7:0] values depending on the Hysteresis value chosen with HYST[3:0], the VBOD+ level reaches an overflow, e.g., for HYST[3:0] = 0d2 the hysteresis is 2 x Level\_Step = 12 mV up to position 253 and position 254 to 255 above must not be used.



# SAM D5x/E5x Family Data Sheet

Electrical Characteristics at 105°C

**Table 55-7. BOD33 Characteristics on V<sub>DD</sub> and V<sub>BAT</sub> Monitoring in Low-Power Mode (During Standby/Backup/Hibernate Modes)**

Symbol	Parameters	Conditions (see Notes 3, 4)	Min	Typ	Max	Unit
VBOD or VBOD- ( see <b>Note 1</b> )	BOD33 threshold level Hysteresis OFF or BOD33 threshold level Hysteresis ON	LEVEL[7:0] = 0x00 (min)	1.39	1.510	1.62	V
		LEVEL[7:0]= 0x19 (recommended value)	1.52	1.659	1.79	
		LEVEL[7:0] = 0x1C (fuse value)	1.54	1.677	1.80	
		LEVEL[7:0] = 0xFF (max)	2.80	3.045	3.28	
VBOD+ (see <b>Note 2</b> )	BOD33 threshold level Hysteresis ON at power voltage rising	LEVEL[7:0] = 0x00 (min)	1.40	1.522	1.63	
		LEVEL[7:0]= 0x19 (recommended value)	1.54	1.672	1.80	
		LEVEL[7:0] = 0x1C (fuse value)	1.56	1.690	1.82	
		LEVEL[7:0] = 0xFF (max)	2.80	3.045	3.28	

**Note:**

1.  $VBOD = VBOD- = 1.5 + LEVEL[7:0] * Level\_Step$  LEVEL[7:0] is calibration setting bus of threshold level.
2.  $VBOD+ = VBOD- + N * HYST\_STEP$  N = 0 to 15 according to HYST[3:0] value HYST\_STEP = Level\_Step.
3. Hysteresis OFF mode, HYST[3:0] = 0x0.
4. Hysteresis ON mode, HYST[3:0] = 0x1 to 0xf; Min/Typ/Max values given for 0x2.
5. At the upper side of LEVEL[7:0] values depending on the Hysteresis value chosen with HYST[3:0], the VBOD+ level reaches an overflow, e.g., for HYST[3:0] = 0d2 the hysteresis is 2 x Level\_Step = 12 mV up to position 253 and position 254 to 255 above must not be used.

# SAM D5x/E5x Family Data Sheet

## Electrical Characteristics at 105°C

**Table 55-8. BOD33 Power Consumption**

Symbol	CPU Mode	Conditions	T <sub>A</sub>	Typ.	Max	Units
I <sub>DD</sub>	Active / Idle	VCC = 1.8V	Max 105°C Typ 25°C	8.52	13.26	μA
		VCC = 3.3V		10.10	15.70	
	Standby with BOD continuous normal mode	VCC = 1.8V		4.71	6.74	
		VCC = 3.3V		6.01	8.59	
	Standby with BOD continuous low power mode or Hibernate mode	VCC = 1.8V		0.15	0.25	
		VCC = 3.3V		0.21	0.33	

### 55.4.3 Analog-to-Digital Converter (ADC) Characteristics (105°C)

**Table 55-9. Operating Conditions <sup>(1)</sup>**

Symbol	Parameters	Conditions	Min	Typ	Max	Unit
Res	Resolution		-	-	12	bits
F <sub>cnv</sub>	Sampling rate - Differential mode SAMPCTRL.OFFCOMP = 0 REFCTRL.REFCOMP = 0	resolution 12 bit (CTRLC.RESSEL=0)	20	-	1231	ksps
		resolution 10 bit (CTRLC.RESSEL=2)	29.09	-	1455	ksps
		resolution 8 bit (CTRLC.RESSEL=3)	35.56	-	1778	ksps
	Sampling rate - Single-Ended mode SAMPCTRL.OFFCOMP = 0 REFCTRL.REFCOMP = 0	resolution 12 bit (CTRLC.RESSEL=0)	20	-	1231	ksps
		resolution 10 bit (CTRLC.RESSEL=2)	26.67	-	1333	ksps
		resolution 8 bit (CTRLC.RESSEL=3)	32	-	1600	ksps
Nb <sub>cycles</sub>	Differential mode Number of ADC clock cycles SAMPCTRL.OFFCOMP=1 and/or REFCTRL.REFCOMP=1	resolution 12 bit (CTRLC.RESSEL=0)	16			cycles
		resolution 10 bit (CTRLC.RESSEL=2)	14			
		resolution 8 bit (CTRLC.RESSEL=3)	12			
	Differential mode Number of ADC clock cycles SAMPCTRL.OFFCOMP=0 REFCTRL.REFCOMP=0 SAMPLEN corresponds to the decimal value of SAMPCTRL.SAMPLEN[5:0] register	resolution 12 bit (CTRLC.RESSEL=0)	SAMPLEN+13			cycles
		resolution 10 bit (CTRLC.RESSEL=2)	SAMPLEN+11			
		resolution 8 bit (CTRLC.RESSEL=3)	SAMPLEN+9			
	Single-ended mode Number of ADC clock cycles SAMPCTRL.OFFCOMP=1 and/or REFCTRL.REFCOMP=1	resolution 12 bit (CTRLC.RESSEL=0)	16			cycles
		resolution 10 bit (CTRLC.RESSEL=2)	15			
		resolution 8 bit (CTRLC.RESSEL=3)	13			
	Single-ended mode Number of ADC clock cycles SAMPCTRL.OFFCOMP=0 REFCTRL.REFCOMP=0 SAMPLEN corresponds to the decimal value of SAMPCTRL.SAMPLEN[5:0] register	resolution 12 bit (CTRLC.RESSEL=0)	SAMPLEN+13			cycles
		resolution 10 bit (CTRLC.RESSEL=2)	SAMPLEN+12			
		resolution 8 bit (CTRLC.RESSEL=3)	SAMPLEN+10			
f <sub>adc</sub>	ADC Clock frequency		320	F <sub>cnv</sub> *Nb <sub>cycles</sub>	16000	kHz
T <sub>s</sub>	Sampling time	SAMPCTRL.OFFCOMP=1 REFCTRL.REFCOMP=1 CTRLC.R2R=1	4			cycles
		SAMPCTRL.OFFCOMP=0 <sup>(3)</sup> REFCTRL.REFCOMP=0 CTRLC.R2R=0	1	-	65	

# SAM D5x/E5x Family Data Sheet

## Electrical Characteristics at 105°C

.....continued

Symbol	Parameters	Conditions	Min	Typ	Max	Unit
Ts	Sampling time with DAC as input	SAMPCTRL.OFFCOMP=1 REFCTRL.REFCOMP=1 CTRLC.R2R=1	(4)			ns
		SAMPCTRL.OFFCOMP=0 <sup>(3)</sup> REFCTRL.REFCOMP=0 CTRLC.R2R=0				
Ts	Sampling time with Temp Sensor or Bandgap as input	SAMPCTRL.OFFCOMP=1 REFCTRL.REFCOMP=1 CTRLC.R2R=1	10000	-	4/fadcmin=25000	ns
		SAMPCTRL.OFFCOMP=0 <sup>(3)</sup> REFCTRL.REFCOMP=0 CTRLC.R2R=0	10000	-	65/fadcmin=406250	
Vcnv	Conversion range	Differential mode	-VREF	-	+VREF	V
		Single-ended mode	0	-	VREF	
Vref	Reference input		1	-	VDDANA-0.4	V
Vin	Input channel range		0	-	VDDANA	V
Vcmn	Input common mode voltage	CTRLC.R2R=1	0	+VREF/2	VDDANA	V
		CTRLC.R2R=0	See Note 2			V
CSAMPLE	Input sampling capacitance		2	2.5	3	pF
RSAMPLE	Input sampling on-resistance		-		2000	Ω
Rref	Reference source resistance			-	2.5	kΩ

**Note:**

- These are based on simulation. These values are not covered by test or characterization.
- Limit the input common mode voltage using following equations (where VCM\_IN is the input channel common mode voltage):  
When CTRLC.R2R=0,  
  - $V_{CM\_IN} < 0.75 \cdot V_{REF}$
  - $V_{CM\_IN} > \text{Maximum of } (0, V_{REF} - V_{DDANA} - 0.7, 1.25 \cdot V_{REF} - V_{DDANA})$
- When OFFCOMP is disabled, Ts is function of SAMPLEN[5:0] register value, ie  $T_s = (\text{SAMPLEN} + 1) / \text{fadc}$ .
- See Ts specified in DAC electrical characteristic.

**Table 55-10. Differential Mode<sup>(1)</sup>**

Symbol	Parameter	Conditions	Measurement			Unit
			Min	Typ	Max	
ENOB	Effective Number of bits	Fadc = 1Msps - R2R disabled	Vddana=3.0V Vref=Vddana	10.5	10.8	11.2
			Vddana=3.0V ExtVref=2.0V	10.5	10.8	11.0
TUE	Total Unadjusted Error <sup>(3)</sup>	Fadc = 1Msps - R2R disabled	Vddana=3.0V Vref=Vddana	-	+/-2.3	+/-5.2
			Vddana=3.0V ExtVref=2.0V	-	+/-2.7	+/-5.7
INL	Integral Non Linearity	Fadc = 1Msps - R2R disabled	Vddana=3.0V Vref=Vddana	-	+/-1.2	+/-1.7
			Vddana=3.0V ExtVref=2.0V	-	+/-1.2	+/-1.5
DNL	Differential Non Linearity	Fadc = 1Msps - R2R disabled	Vddana=3.0V Vref=Vddana	-	+/-0.98	-1/+1
			Vddana=3.0V ExtVref=2.0V	-	+/-0.96	-1/+1

# SAM D5x/E5x Family Data Sheet

## Electrical Characteristics at 105°C

.....continued

Symbol	Parameter	Conditions		Measurement			Unit
				Min	Typ	Max	
Gain	Gain Error with REFCTRL.REFCOMP=1	Fadc = 1Msps	Vddana=3.0V Vref=Vddana	-0.21	-0.02	+0.2	%
			Vddana=3.0V ExtVref=2.0V	-0.12	+0.03	-0.21	
			Vddana=3.0V 1V internal Ref	-10	-1	+6.7	
			Vddana=3.0V Vref=Vddana/2	-0.48	+0.2	+0.75	
Gain	Gain Error with REFCTRL.REFCOMP=0	Fadc = 1Msps	Vddana=3.0V Vref=Vddana	-0.3	-0.001	+0.2	mV
			Vddana=3.0V ExtVref=2.0V	-0.94	-0.05	-0.7	
			Vddana=3.0V 1V internal Ref	-10	-1	+5.9	
			Vddana=3.0V Vref=Vddana/2	-1.2	+0.11	+1.28	
Offset	Offset Error with SAMPCTRL.OFFCOMP=1	Fadc = 1Msps	Vddana=3.0V Vref=Vddana	-3.6	-0.24	+3.1	%
			Vddana=3.0V ExtVref=2.0V	-3.3	-0.2	+2.7	
			Vddana=3.0V 1V internal Ref	-3.6	-0.2	+2.9	
			Vddana=3.0V Vref=Vddana/2	-3.6	-0.34	+3.3	
Offset	Offset Error with SAMPCTRL.OFFCOMP=0	Fadc = 1Msps	Vddana=3.0V Vref=Vddana	-11.9	+0.03	+/-12.3	mV
			Vddana=3.0V ExtVref=2.0V	-12.2	-0.03	+12.4	
			Vddana=3.0V 1V internal Ref	-14.3	+0.5	+14.7	
			Vddana=3.0V Vref=Vddana/2	-13.6	+0.5	+14	
SFDR	Spurious Free Dynamic Range	Fs = 1Msps Fin = 14kHz (2)	Vddana=3.0V Vref=Vddana	76.6	79.6	83.5	dB
SINAD	Signal to Noise and Distortion ratio			65.2	67.2	68.9	
SNR	Signal to Noise ratio			64.6	66.5	68.2	
THD	Total Harmonic Distortion			-91.6	-82.9	-78.6	
Nrms	Noise RMS	constant input voltage	Vddana=3.0V ExtVref=2.0V	0.2	0.4	2.4	mV
			Vddana=3.0V Vref=Vddana	0.15	0.25	2.5	

**Note:**

1. These values are based on characterization. These values are not covered by test limits in production.
2. All values expressed in decibel refer to the full scale input and are tested with an input signal 0.35dB below full scale; THD measured on the first seven harmonics of the input signal.
3. With REFCTRL.REFCOMP=1 and SAMPCTRL.OFFCOMP=1.

**Table 55-11. Single Ended Mode (1)**

Symbol	Parameter	Conditions		Measurement			Unit
				Min	Typ	Max	
ENOB	Effective Number of bits	Fadc = 1Msps - R2R disabled	Vddana=3.0V Vref=Vddana	8.9	9.25	9.9	bits
			Vddana=3.0V ExtVref=2.0V	8.85	9.49	9.71	

# SAM D5x/E5x Family Data Sheet

## Electrical Characteristics at 105°C

.....continued

Symbol	Parameter	Conditions		Measurement			Unit	
				Min	Typ	Max		
TUE	Total Unadjusted Error <sup>(3)</sup>	Fadc = 1Msps - R2R disabled	Vddana=3.0V Vref=Vddana	-	+/-10.9	+/-18.3	LSB	
			Vddana=3.0V ExtVref=2.0V	-	+/-10.5	+/-19.1		
INL	Integral Non Linearity	Fadc = 1Msps - R2R disabled	Vddana=3.0V Vref=Vddana	-	+/-2.3	+/-3.2		
			Vddana=3.0V ExtVref=2.0V	-	+/-2.3	+/-3		
DNL	Differential Non Linearity	Fadc = 1Msps - R2R disabled	Vddana=3.0V Vref=Vddana	-	+/-0.98	-1/+1		
			Vddana=3.0V ExtVref=2.0V	-	+/-0.97	-1/+1.2		
Gain	Gain Error with REFCTRL.REFCOMP=1	Fadc = 1Msps	Vddana=3.0V Vref=Vddana	-0.3	-0.01	+0.3		%
			Vddana=3.0V ExtVref=2.0V	-0.16	+0.02	+0.3		
			Vddana=3.0V 1V internal Ref	-11	-1.1	+7		
			Vddana=3.0V Vref=Vddana/2	-0.5	+0.13	+0.7		
Offset	Offset Error with SAMPCTRL.OFFCOMP=1	Fadc = 1Msps	Vddana=3.0V Vref=Vddana	-19	-7.2	+9.3	mV	
			Vddana=3.0V ExtVref=2.0V	-20.7	-3.3	+17		
			Vddana=3.0V 1V internal Ref	-24	-4.2	+26		
			Vddana=3.0V Vref=Vddana/2	-27	-3.1	+24		
SFDR	Spurious Free Dynamic Range	Fs = 1Msps Fin = 14kHz <sup>(2)</sup>	Vddana=3.0V Vref=Vddana	67.9	69.2	76.3	dB	
SINAD	Signal to Noise and Distortion ratio			55.7	57.5	61.1		
SNR	Signal to Noise ratio			54.7	56.9	60.6		
THD	Total Harmonic Distortion			-73.7	-68.2	-65.8		
Nrms	Noise RMS	constant input voltage	Vddana=3.0V ExtVref=2.0V	0.35	1.0	2.1	mV	
			Vddana=3.0V Vref=Vddana	0.3	0.35	1.7		

**Note:**

1. These values are based on characterization. These values are not covered by test limits in production.
2. All values expressed in decibel refer to the full scale input and are tested with an input signal 0.35dB below full scale; THD measured on the first seven harmonics of the input signal.
3. With REFCTRL.REFCOMP=1 and SAMPCTRL.OFFCOMP=1.

# SAM D5x/E5x Family Data Sheet

## Electrical Characteristics at 105°C

**Table 55-12. Power Consumption**

Symbol	Parameters	Conditions	Ta	Typ.	Max	Units
IDD VDDANA	Differential mode	fs = 1 Msps / Reference buffer disabled / BIASREFBUF = '111', BIASREFCOMP = '111' VDDANA = VREF = 3.0V	Max 105°C Typ 25°C	279	326	µA
		fs = 1 Msps / Reference buffer enabled / BIASREFBUF = '111', BIASREFCOMP = '111' VDDANA = VREF = 3.0V		482	686	
		fs = 10 ksps / Reference buffer disabled / BIASREFBUF = '111', BIASREFCOMP = '111' VDDANA = VREF = 3.0V		28	85	
		fs = 10 ksps / Reference buffer enabled / BIASREFBUF = '111', BIASREFCOMP = '111' VDDANA = VREF = 3.0V		241	435	
	Single Ended mode	fs = 1 Msps / Reference buffer disabled / BIASREFBUF = '111', BIASREFCOMP = '111' VDDANA = VREF = 3.0V	Max 105°C Typ 25°C	307	361	µA
		fs = 1 Msps / Reference buffer enabled / BIASREFBUF = '111', BIASREFCOMP = '111' VDDANA = VREF = 3.0V		499	730	
		fs = 10 ksps / Reference buffer disabled / BIASREFBUF = '111', BIASREFCOMP = '111' VDDANA = VREF = 3.0V		38	126	
		fs = 10 ksps / Reference buffer enabled / BIASREFBUF = '111', BIASREFCOMP = '111' VDDANA = VREF = 3.0V		245	448	

### 55.4.4 Digital to Analog Converter (DAC) Characteristics (105°C)

**Table 55-13. Differential Mode (1)**

Symbol	Parameters	Conditions	Min.	Typ.	Max.	Unit
INL	Integral Non Linearity, Best Fit curve from 0x080 to 0xF7F	i12clk=12 MHz VDDANA = 3.0V - External Ref = 2.0V Clload = 50pF	-	±2.4	±3.4	LSB
		i12clk=12 MHz VDDANA = 3.0V - 1V Internal Ref Clload = 50pF	-	±3.2	±4.2	
DNL	Differential Non Linearity, Best Fit curve from 0x080 to 0xF7F	i12clk=12 MHz VDDANA = 3.0V - External Ref = 2.0V Clload = 50pF	-	±2.4	±3.6	LSB
		i12clk=12 MHz VDDANA = 3.0V - 1V Internal Ref Clload = 50pF	-	±3.5	±5.4	
Gerr	Gain Error	External Reference voltage	-	±0.4	±1.7	% FSR
		1.0V Internal Reference voltage	-	±0.8	±8.5	
Offerr	Offset Error	External Reference voltage	-	±13	±44	mV
		1.0V Internal Reference voltage	-	±8	±64	
ENOB	Effective Number Of Bits	Fs = 1 Ms/s - External Ref - CTRL = 0x2	9.7	10.7	11.0	Bits
SNR	Signal to Noise ratio		61.3	68.6	74.5	dB
THD	Total Harmonic Distortion		-82.3	-72.5	-58.9	dB

**Note:**

1. These values are based on characterization. These values are not covered by test limits in production.

# SAM D5x/E5x Family Data Sheet

## Electrical Characteristics at 105°C

**Table 55-14. Single-Ended Mode (1)**

Symbol	Parameters	Conditions	Min.	Typ.	Max.	Unit
INL	Integral Non Linearity, Best Fit curve from 0x080 to 0xF7F	i12clk=12 MHz VDDANA = 3.0V - External Ref = 2.0V Clod = 50pF	-	±2.7	±4.0	LSB
		i12clk=12 MHz VDDANA = 3.0V - 1V Internal Ref Clod = 50pF	-	±5.2	±8.7	
DNL	Differential Non Linearity, Best Fit curve from 0x080 to 0xF7F	i12clk=12 MHz VDDANA = 3.0V - External Ref = 2.0V Clod = 50pF	-	±3.5	±6.1	
		i12clk=12 MHz VDDANA = 3.0V - 1V Internal Ref Clod = 50pF	-	±6.4	±9.4	
Gerr	Gain Error	External Reference voltage	-	±0.3	±1.6	% FSR
		1.0V Internal Reference voltage	-	±0.8	±8.6	
Offerr	Offset Error	External Reference voltage	-	±7	±25	mV
		1.0V Internal Reference voltage	-	±2	±19	
ENOB	Effective Number of Bits	Fs = 1 Ms/s - External Ref - CCTRL = 0x2	9.1	10.3	10.8	Bits
SNR	Signal to Noise Ratio		63.5	68.6	74.5	dB
THD	Total Harmonic Distortion		-82.3	-72.8	-61.0	dB

**Note:**

1. These values are based on characterization. These values are not covered by test limits in production.

**Table 55-15. Power Consumption**

Symbol	Parameters	Conditions	Ta	Min.	Typ.	Max.	Unit
IDDANA	Differential Mode, DC supply current, 2 output channels - without load	fs = 1 Msps, CCTRL = 0x2, VREF > 2.4V, VCC = 3.3V	Max. 105°C Typ. 25°C	-	384	593	µA
		fs = 10 ksps, CCTRL = 0x0, VREF < 2.4V, VCC = 3.3V		-	283	457	
	Single-Ended Mode, DC supply current, 2 output channels - without load	fs = 1 Msps, CCTRL = 0x2, VREF > 2.4V, VCC = 3.3V		-	306	493	µA
		fs = 10 ksps, CCTRL = 0x0, VREF < 2.4V, VCC = 3.3V		-	230	369	

### 55.4.5 Analog Comparator (AC) Characteristics (105°C)

**Table 55-16. Analog Comparator Characteristics**

Symbol	Parameters	Conditions	Min	Typ	Max	Unit
Off <sup>(1)</sup>	Offset	High speed COMPCTRLn.SPEED = 0x3	-22	±3	22	mV
Tpd	Propagation Delay Vcm=Vddana/2, Vin = +/-100mV overdrive from Vcm	High speed COMPCTRLn.SPEED = 0x3	-	24.1	42	ns
Tstart	Startup time	High speed COMPCTRLn.SPEED = 0x3	-	4.7	8	µs

**Note:**

1. Hysteresis disabled.

**Table 55-17. Power Consumption**

Symbol	Parameters	Conditions	Ta	Typ.	Max.	Unit
I <sub>DDANA</sub>	Current consumption for One AC enabled, Hysteresis disabled voltage scaler disabled	COMPCTRLn.SPEED=0x3, V <sub>DDANA</sub> =3.3V	Max. 105°C Typ. 25°C	59	103	μA
	Current consumption Voltage Scaler only	V <sub>DDANA</sub> =3.3V		11	18	

### 55.4.6 PTC Characteristics

The values in the following Power Consumption table are measured values of power consumption under the following conditions:

**Operating Conditions:**

VDD = 3.0V

**Clocks**

DFLL48M used as main clock source, running undivided at 48MHz

CPU is running on flash with 2 wait states, at 48MHz

PTC running at 4MHz

**PTC Configuration**

Mutual-capacitance mode

One touch channel

**System Configuration**

Standby sleep mode enabled

RTC running on ULP32K: used to define the PTC scan rate, through the event system

RTC interrupts (wakeup) the CPU to perform PTC scans



# SAM D5x/E5x Family Data Sheet

## Electrical Characteristics at 105°C

**Table 55-18. Power Consumption (1)**

Symbol	Parameters	PTC scan rate (msec)	Oversamples	Ta	Typ.	Max	Units
IDD	Current Consumption	10	4	Max 105°C Typ 25°C	137	2174	μA
			16		146	2194	
		50	4		77	2098	
			16		79	2104	
		100	4		68	2092	
			16		69	2095	
		200	4		64	2086	
			16		65	2089	

**Note:**

1. These are based on characterization.

## 55.5 NVM Characteristics

**Table 55-19. NVM Flash Read Wait States for Worst Case Conditions**

CPU Fmax (MHz)	0 WS	1 WS	2 WS	3 WS	4 WS	5 WS	6 WS	Auto WS
Read Operations	1 cycle	2 cycles	3 cycles	4 cycles	5 cycles	6 cycles	7 cycles	n cycles
VDD > 1.71V	19	38	57	76	95	100	120	120

Maximum operating frequencies are given in the table above, but are limited by the Embedded Flash access time when the processor is fetching code out of it. These tables provide the device maximum operating frequency defined by the field RWS of the NVMCTRL CTRLA register when automatic wait states (AUTOWS) is disabled. This field defines the number of Wait states required to access the Embedded Flash Memory.

### 55.6 Oscillators Characteristics (105°C)

#### 55.6.1 Crystal Oscillator (XOSC) Characteristics (105°C)

**Table 55-20. Multiple Crystal Oscillator Electrical Characteristics**

Symbol	Parameter	Conditions	Min.	Typ.	Max	Units
Tstart	Startup time	F = 8MHz - CL=20 pF - Cshunt = 2 pF - IMULT=0x3	-	39700	72200	Cycles
		F = 16MHz - CL=20 pF - Cshunt = 1,5 pF - IMULT=0x4	-	37550	73000	
		F = 24MHz - CL=20 pF - Cshunt = 2,5 pF - IMULT=0x5	-	32700	68500	
		F = 48MHz - CL=13 pF - Cshunt = 5 pF - IMULT=0x6	-	18400	38500	

**Table 55-21. Power Consumption**

Symbol	Parameters	Conditions	Ta	Typ.	Max.	Units
IDD	Current Consumption	F = 8 MHz - CL = 20 pF - IMULT = 0x3, ENALC = OFF	Max. 105°C, Typ. 25°C	0.43	1.56	mA
		ENALC = ON		0.16	1.16	
		F = 16 MHz - CL = 20 pF - IMULT = 0x5, ENALC = OFF		1.31	3.23	
		ENALC = ON		0.25	1.33	
		F = 32 MHz - CL = 13 pF - IMULT = 0x5, ENALC = OFF		2.92	5.74	
		ENALC = ON		0.40	1.92	
		F = 48 MHz - CL = 13 pF - IMULT = 0x6, ENALC = OFF		2.70	5.82	
		ENALC = ON		0.76	2.64	

#### 55.6.2 External 32 kHz Crystal Oscillator (XOSC32K) Characteristics (105°C)

**Table 55-22. Power Consumption**

Symbol	Parameter	Conditions	Ta	Gain Mode	Typ.	Max.	Units
IDD	Current consumption	VDD=3.0V	Max 105°C Typ 25°C	Std.	1.5	2.5	µA
				High	1.9	3.3	

# SAM D5x/E5x Family Data Sheet

## Electrical Characteristics at 105°C

### 55.6.3 Internal Ultra Low Power 32 kHz RC Oscillator (OSCULP32K) Characteristics (105°C)

Table 55-23. Ultra-Low-Power Internal 32 kHz RC Oscillator Electrical Characteristics

Symbol	Parameter	Calibration	Conditions	Min.	Typ.	Max	Units
F <sub>OUT</sub>	Output frequency	Factory default & without user software calibration	[-40, +105]°C, VDDANA>1.71V	26.00	32.768	39.50	kHz
		With user software calibration	Recalibrate using XOSC as reference Clock source	32.28		33.25	
			Recalibrate using DFLL as reference Clock source	31.29		33.91	

### 55.6.4 Digital Frequency Locked Loop (DFLL48M) Characteristics (105°C)

Table 55-24. DFLL48M Characteristics - Open Loop Mode <sup>(1)</sup>

Symbol	Parameter	Conditions	Min.	Typ.	Max.	Units
F <sub>OpenOUT</sub>	Output frequency	DFLLVAL after Reset LDO Regulator mode, [-40, 105]°C	45.57	48	50.09	MHz
		DFLLVAL after Reset LDO Regulator mode, [0, 60]°C	47.12	48	48.9	
T <sub>OpenSTARTUP</sub>	Startup time	DFLLVAL after Reset F <sub>OUT</sub> within 90% of final value	-	4.3	6.5	µs

**Note:**

- DFLL48 in open loop can be used only with LDO regulator.

Table 55-25. DFLL48M Power Consumption

Symbol	Parameter	Conditions	T <sub>a</sub>	Min.	Typ.	Max.	Units
I <sub>DD</sub>	Current Consumption	Open Loop mode - DFLLVAL after reset VCC = 3.3V	Max. 105°C Typ. 25°C	-	400	1400	µA
		Closed Loop mode - f <sub>REF</sub> = 32.768 kHz VCC = 3.3V		-	404	1390	

### 55.6.5 Fractional Digital Phase Lock Loop (FDPLL) Characteristics (105°C)

Table 55-26. Fractional Digital Phase Lock Loop Characteristics <sup>(2)</sup>

Symbol	Parameter	Conditions	Min.	Typ.	Max.	Units
J <sub>p</sub>	Period jitter (Peak-Peak value)	f <sub>IN</sub> = 32 kHz, f <sub>OUT</sub> = 96 MHz	-	1.9	2.9	%
		f <sub>IN</sub> = 32 kHz, f <sub>OUT</sub> = 200 MHz	-	3.4	5.6	
		f <sub>IN</sub> = 3.2 MHz, f <sub>OUT</sub> = 96 MHz	-	2.0	3.1	
		f <sub>IN</sub> = 3.2 MHz, f <sub>OUT</sub> = 200 MHz	-	4.3	7.1	
Duty <sup>(1)</sup>	Duty cycle	-	-	50	-	%

# SAM D5x/E5x Family Data Sheet

## Electrical Characteristics at 105°C

**Note:**

1. These are based on simulation. These values are not covered by test or characterization.
2. These FDPLL200M characteristics are applicable with LDO regulator and a direct reference (i.e., REFCLK is XOSC or XOSC32K, not GCLK).

**Table 55-27. Power Consumption**

Symbol	Parameter	Conditions	TA	Typ.	Max.	Units
I <sub>DD</sub>	Current Consumption	Ck = 96 MHz, VDD = 3.3V	Max. 105°C	0.9	1.8	mA
		Ck = 200 MHz, VDD = 3.3V	Typ. 25°C	2.0	2.6	

### 56. Electrical Characteristics at 125°C

The specifications for 125°C temperature devices are identical to those shown in [54. Electrical Characteristics at 85°C](#), with the exception of the parameters listed in this chapter.

#### 56.1 General Operating Ratings (125°C)

The device must operate within the ratings listed below in order for all other electrical characteristics and typical characteristics of the device to be valid.

**Table 56-1. General Operating Conditions**

Symbol	Description	Min.	Typ.	Max.	Units
T <sub>A</sub>	Temperature range	-40	25	125	°C
T <sub>J</sub>	Junction temperature	-	-	145	°C

#### 56.2 Injection Current (125°C)

Stresses beyond those listed in the table below may cause permanent damage to the device. This is a stress rating only and functional operation of the device at these or other conditions beyond those indicated in the operational sections of this specification is not implied. Exposure to absolute maximum rating conditions for extended periods may affect device reliability.

**Table 56-2. Injection Current<sup>(1, 2)</sup>**

Symbol	Description	min	Typ.	max	Unit	Comments
I <sub>ICL</sub>	Input Low Injection Current	-15	-	-	mA	Note: 1, 4, 5 This Parameter applies to all pins.
I <sub>ICH</sub>	Input High Injection Current	-	-	15	mA	Note: 2, 3, 4, 5 This parameter applies to all pins, with the exception of 5V tolerant pins.
∑I <sub>ICT</sub>	Total Input Injection Current (Sum of all I/O and control pins) Absolute value of  ∑I <sub>ICT</sub>	-	-	18	mA	Absolute instantaneous sum of all ± input injection currents from all I/O pins.  <div style="border: 1px solid black; padding: 5px; width: fit-content; margin: 0 auto;"> <math display="block">( I_{ICL}  +  I_{ICH} ) \leq \sum I_{ICT}</math> </div>

**Note:**

1. VIL source < (VSS - 0.6). Characterized but not tested.
2. VIH source > (VDDIO + 0.6) for non-5V tolerant pins only.
3. Digital 5V tolerant pins do not have an internal high side diode to VDDIO, and therefore, cannot tolerate any “positive” input injection current.
4. Injection currents > | 0 | can affect the ADC results by approximately 4 to 6 counts (i.e., VIH Source > (VDDIO + 0.6) or VIL source < (GND - 0.6)).
5. Any number and/or combination of I/O pins not excluded under IICL or IICH conditions are permitted provided the “absolute instantaneous” sum of the input injection currents from all pins do not exceed the specified  $\Sigma$ IICT limit. To limit the injection current the user must insert a resistor in series RS between input source voltage and device pin. The resistor value is calculated according to:
  - For negative Input voltages less than (GND-0.6):  $RS \geq (((GND - 0.6) - VIL \text{ source}) / IICL)$
  - For positive input voltages greater than (VDDIO+0.6):  $RS \geq ((VIH \text{ source} - VDDIO) / IICH)$
  - For Vpin voltages > VDD and < GND then RS = the larger of the values calculated above

### 56.3 Supply Characteristics (125°C)

**Table 56-3. Power Supply Current Requirement**

Symbol	Conditions	Current	Units
		Max.	
I <sub>input</sub>	Power-up Maximum Current	12	mA

**Note:** I<sub>input</sub> is the minimum requirement for the power supply connected to the device.

### 56.4 Maximum Clock Frequencies (125°C)

**Table 56-4. Maximum Peripheral Clock Frequencies<sup>(1)</sup>**

Symbol	Description	Max.	Units
f <sub>CPU</sub>	CPU clock frequency	100	MHz
f <sub>AHB</sub>	AHB clock frequency	100	MHz
f <sub>APBX, x = {A, B, C, D}</sub>	APBA, APBB, APBC and APBD clock frequency	100	MHz
f <sub>GCLK_EIC</sub>	EIC input clock frequency	90	MHz
f <sub>GCLK_FREQM_MSR</sub>	FREQM Measure	180	MHz
f <sub>GCLK_FREQM_REF</sub>	FREQM Reference	90	MHz
f <sub>GCLK_EVSYS_CHANNEL_x, x = {0, ..., 11}</sub>	EVSYS channel ‘x’ input clock frequency	90	MHz
f <sub>GCLK_SERCOMx_CORE, x = {0, ..., 7}</sub>	SERCOMx input clock frequency	90	MHz
f <sub>GCLK_CANx, x = {0, 1}</sub>	CANx input clock frequency	90	MHz
f <sub>GCLK_I2S</sub>	I <sup>2</sup> S input clock frequency	90	MHz
f <sub>GCLK_SDHCx_CORE, x = {0, 1}</sub>	SDHCx input clock frequency	150	MHz

# SAM D5x/E5x Family Data Sheet

## Electrical Characteristics at 125°C

.....continued

Symbol	Description	Max.	Units
$f_{\text{GCLK\_TCCx, } x = \{0, \dots, 4\}}$	TCCx input clock frequency	180	MHz
$f_{\text{GCLK\_TCx, } x = \{0, \dots, 3\}}$	TC0, TC1, TC2, TC3 input clock frequency	180	MHz
$f_{\text{GCLK\_PDEC}}$	PDEC input clock frequency	180	MHz
$f_{\text{GCLK\_CCL}}$	CCL input clock frequency	90	MHz
$f_{\text{GCLK\_CM4\_TRACE}}$	CM4 Trace input clock frequency	100	MHz
$f_{\text{GCLK\_AC}}$	AC digital input clock frequency	90	MHz
$f_{\text{GCLK\_ADCx, } x = \{0, 1\}}$	ADCx input clock frequency	90	MHz
$f_{\text{GCLK\_DAC}}$	DAC input clock frequency	90	MHz

**Note:**

1. These values are based on simulation. They are not covered by production test limits or characterization.

### 56.5 Power Consumption (125°C)

The values in this section are measured values of power consumption under the following conditions, except where noted:

- **Operating Conditions**

- CPU is running on Flash with automatic wait state
- Low-power cache enabled
- BOD33 is disabled
- I/Os are inactive input mode with input trigger disabled

- **Oscillators**

- XOSC0 (crystal oscillator) running with external 32 MHz crystal
- XOSC32K (32 kHz crystal oscillator) running with external 32 kHz crystal in LP mode
- FDPLL is using XOSC32K as reference on LDO and external clock 32768 on Buck mode
- DFLL48M is using XOSC32K as reference

# SAM D5x/E5x Family Data Sheet

## Electrical Characteristics at 125°C

**Table 56-5. Active Current Consumption - Active Mode**

Mode	conditions	Regulator	Clock	VDD	T <sub>A</sub>	Typ.	Max.	Units
ACTIVE	COREMARK (1)	LDO	FDPLL 100 MHz	1.8	Max. at 125°C Typ at 25°C	136	229	uA/Mhz
				3.3		137	232	
			DFLL 48 MHz	1.8		136	370	
				3.3		136	371	
			XOSC 32 MHz	1.8		146	611	
				3.3		149	613	
		BUCK	FDPLL 120 MHz	1.8		103	215	
				3.3		65	176	
			DFLL 48 MHz	1.8		102	324	
				3.3		63	242	
			XOSC 32 MHz	1.8		110	505	
				3.3		73	370	
IDLE	NA	LDO	FDPLL 100 MHz	1.8	21	114		
				3.3	23	116		
			DFLL 48 MHz	1.8	21	252		
				3.3	21	252		
			XOSC 32 MHz	1.8	25	367		
				3.3	27	371		
		BUCK	FDPLL 100 MHz	1.8	16	89		
				3.3	11	78		
			DFLL 48 MHz	1.8	16	194		
				3.3	10	147		
			XOSC 32 MHz	1.8	21	287		
				3.3	19	223		

**Note:**

1. System Configuration used:
  - MCLK all APB clocks masked except MCLK and NVMCTRL
  - MCLK.AHBMASK = 0x00C00FFF
  - CMCC enabled



# SAM D5x/E5x Family Data Sheet

## Electrical Characteristics at 125°C

**Table 56-6. Standby, Hibernate, Backup and Off Mode Current Consumption**

Mode	Conditions	Regulator Mode	V <sub>CC</sub>	T <sub>A</sub>	Typ.	Max.	Units
STANDBY	fast wake-up disabled (PM.STDBYCFG.FASTWKUP=0x0), no peripheral running No System RAM retained (PM.STDBYCFG.RAMCFG=0x2). 8KB backup RAM retained	LDO	1.8V	Max at 125°C Typ at 25°C	43	5834	μA
			3.3V		43	5851	
		BUCK	1.8V		26	3950	
			3.3V		17	2817	
	fast wake-up enabled (PM.STDBYCFG.FASTWKUP=0x3), no peripheral running No System RAM retained (PM.STDBYCFG.RAMCFG=0x2). 8KB backup RAM retained	LDO	1.8V		85	8707	
			3.3V		85	8724	
		BUCK	1.8V		65	6766	
			3.3V		47	5269	
	fast wake-up disabled (PM.STDBYCFG.FASTWKUP=0x0), RTC running on XOSC32K No System RAM retained (PM.STDBYCFG.RAMCFG=0x2). 8KB backup RAM retained	LDO	1.8V		43	5843	
			3.3V		44	5860	
		BUCK	1.8V		26	3965	
			3.3V		18	2891	
	fast wake-up disabled (PM.STDBYCFG.FASTWKUP=0x0), RTC running on XOSC32K 32KB System RAM retained (PM.STDBYCFG.RAMCFG=0x1). 8KB backup RAM retained	LDO	1.8V		45	6085	
			3.3V		46	6102	
		BUCK	1.8V		27	4137	
			3.3V		19	3012	
	fast wake-up disabled (PM.STDBYCFG.FASTWKUP=0x0), RTC running on XOSC32K Full System RAM retained (PM.STDBYCFG.RAMCFG=0x0). 8KB backup RAM retained	LDO	1.8V		53	7049	
			3.3V		53	7068	
		BUCK	1.8V		32	4923	
			3.3V		22	3479	
	fast wake-up enabled (PM.STDBYCFG.FASTWKUP=0x3), no peripheral running Full System RAM retained (PM.STDBYCFG.RAMCFG=0x0). 8KB backup RAM retained	LDO	1.8V		101	5543	
			3.3V		101	5571	
		BUCK	1.8V		78	4266	
			3.3V		55	3075	
fast wake-up enabled (PM.STDBYCFG.FASTWKUP=0x3), RTC running on XOSC32K Full System RAM retained (PM.STDBYCFG.RAMCFG=0x0). 8KB backup RAM retained	LDO	1.8V	102	5563			
		3.3V	103	5588			
	BUCK	1.8V	79	4270			
		3.3V	56	3080			

# SAM D5x/E5x Family Data Sheet

## Electrical Characteristics at 125°C

.....continued

Mode	Conditions	Regulator Mode	V <sub>CC</sub>	T <sub>A</sub>	Typ.	Max.	Units
HIBERNATE	no peripheral running No System RAM retained (PM.HIBCFG.RAMCFG=0x2) No backup RAM retained (PM.HIBCFG.BRAMCFG=0x2)	LDO	1.8V	Max at 125°C Typ at 25°C	6	316	µA
			3.3V		6	320	
		BUCK	1.8V		3	216	
			3.3V		3	221	
	RTC is running on XOSC32K No System RAM retained (PM.HIBCFG.RAMCFG=0x2) No backup RAM retained (PM.HIBCFG.BRAMCFG=0x2)	LDO	1.8V		6	318	
			3.3V		7	322	
		BUCK	1.8V		3	217	
			3.3V		3	223	
	RTC is running on XOSC32K No System RAM retained (PM.HIBCFG.RAMCFG=0x2) 4 KB backup RAM retained (PM.HIBCFG.BRAMCFG=0x1)	LDO	1.8V		7	359	
			3.3V		8	364	
		BUCK	1.8V		3	244	
			3.3V		4	250	
	RTC is running on XOSC32K No System RAM retained (PM.HIBCFG.RAMCFG=0x2) 8 KB backup RAM retained (PM.HIBCFG.BRAMCFG=0x0)	LDO	1.8V		7	400	
			3.3V		8	405	
		BUCK	1.8V		4	273	
			3.3V		4	279	
	RTC is running on XOSC32K 32 KB System RAM retained (PM.HIBCFG.RAMCFG=0x1) 8KB backup RAM retained (PM.HIBCFG.BRAMCFG=0x0)	LDO	1.8V		9	636	
			3.3V		10	641	
		BUCK	1.8V		5	430	
			3.3V		4	434	
	RTC is running on XOSC32K Full System RAM retained (PM.HIBCFG.RAMCFG=0x0) 8 KB backup RAM retained (PM.HIBCFG.BRAMCFG=0x0)	LDO	1.8V		16	1574	
			3.3V		17	1578	
		BUCK	1.8V		9	1061	
			3.3V		7	1084	
BACKUP	powered by VDDIO, no RTC running VDDIO+VDDANA consumption No backup RAM retained (PM.BKUPCFG.BRAMCFG=0x2)		1.8V	Max at 125°C Typ at 25°C	2.1	303.5	µA
			3.3V		2.5	307.8	
	powered by VDDIO with RTC running on XOSC32K VDDIO+VDDANA consumption No backup RAM retained (PM.BKUPCFG.BRAMCFG=0x2)		1.8V		2.7	304.8	
			3.3V		3.3	309.5	
	powered by VDDIO, no RTC running VDDIO+VDDANA consumption 4 KB backup RAM retained (PM.BKUPCFG.BRAMCFG=0x1)		1.8V		2.4	344.6	
			3.3V		2.8	348.7	
	powered by VDDIO, no RTC running VDDIO+VDDANA consumption 8 KB backup RAM retained (PM.BKUPCFG.BRAMCFG=0x0)		1.8V		2.7	385.1	
			3.3V		3.1	389.6	
	Battery backup mode powered by VBAT with RTC running on XOSC32K VBAT consumption No backup RAM retained (PM.BKUPCFG.BRAMCFG=0x2), BOD33 enabled in sampled mode PSEL prescaler set to 0x7 (div 256)		1.8V		2.7	305	
			3.3V		3.3	310	
OFF	-		1.8V	0.191	26.35		
			3.3V	0.331	31.07		

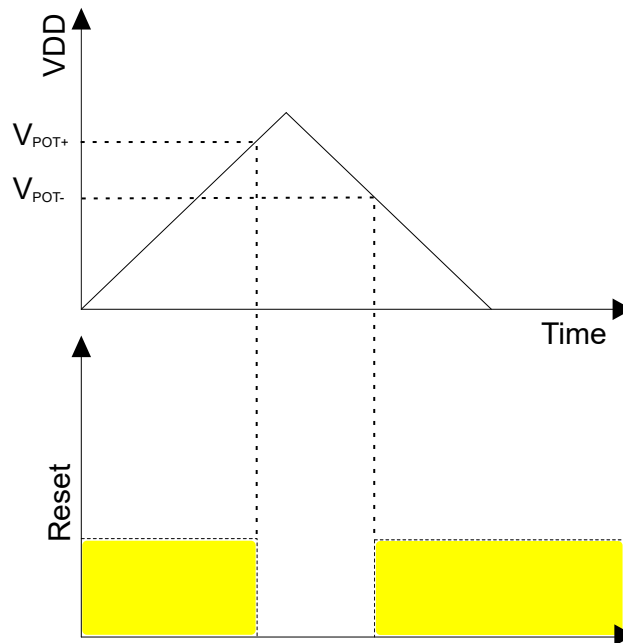
### 56.6 Analog Characteristics (125°C)

#### 56.6.1 Power-On Reset (POR) Characteristics (125°C)

Table 56-7. POR Characteristics

Symbol	Parameters	Min.	Typ.	Max.	Unit
$V_{POT+}$	Voltage threshold Level on $V_{DDIO}$ rising	1.52	1.58	1.65	V
$V_{POT-}$	Voltage threshold Level on $V_{DDIO}$ falling	0.97	1.26	1.36	V

Figure 56-1. POR Operating Principle



**Note:** The shaded area indicates that the device is in a Reset state.

#### 56.6.2 Brown-Out Detectors (BOD) Characteristics (125°C)

Figure 56-2. BOD33 Hysteresis OFF

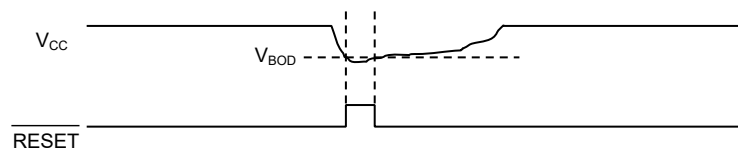
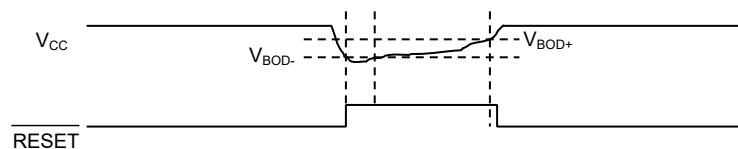


Figure 56-3. BOD33 Hysteresis ON



# SAM D5x/E5x Family Data Sheet

Electrical Characteristics at 125°C

**Table 56-8. BOD33 Characteristics on V<sub>DD</sub> and V<sub>BAT</sub> Monitoring in Normal Mode (During Power-up Phase and Active Mode)**

Symbol	Parameters	Conditions (see Notes 3, 4)	Min	Typ	Max	Unit
VBOD or VBOD- ( see <b>Note 1</b> )	BOD33 threshold level Hysteresis OFF or BOD33 threshold level Hysteresis ON	LEVEL[7:0] = 0x00 (min)	1.45	1.50	1.55	V
		LEVEL[7:0] = 0x19 (recommended value)	1.6	1.65	1.71	
		LEVEL[7:0]= 0x1C (fuse value)	1.62	1.67	1.73	
		LEVEL[7:0] = 0xFF (max)	2.93	3.040	3.13	
VBOD+ (see <b>Note 2</b> )	BOD33 threshold level Hysteresis ON at power voltage rising	LEVEL[7:0] = 0x00 (min)	1.46	1.520	1.57	
		LEVEL[7:0]= 0x19 (recommended value)	1.61	1.669	1.72	
		LEVEL[7:0] = 0x1C (fuse value)	1.63	1.687	1.74	
		LEVEL[7:0] = 0xFF (max)	2.93	3.041	3.32	

**Note:**

1.  $VBOD = VBOD- = 1.5 + LEVEL[7:0] * Level\_Step$  LEVEL[7:0] is calibration setting bus of threshold level.
2.  $VBOD+ = VBOD- + N * HYST\_STEP$  N = 0 to 15 according to HYST[3:0] value HYST\_STEP = Level\_Step.
3. Hysteresis OFF mode, HYST[3:0] = 0x0.
4. Hysteresis ON mode, HYST[3:0] = 0x1 to 0xf; Min/Typ/Max values given for 0x2.
5. At the upper side of LEVEL[7:0] values depending on the Hysteresis value chosen with HYST[3:0], the VBOD+ level reaches an overflow, e.g., for HYST[3:0] = 0d2 the hysteresis is 2 x Level\_Step = 12 mV up to position 253 and position 254 to 255 above must not be used.

# SAM D5x/E5x Family Data Sheet

Electrical Characteristics at 125°C

**Table 56-9. BOD33 Characteristics on V<sub>DD</sub> and V<sub>BAT</sub> Monitoring in Low-Power Mode (During Standby/Backup/Hibernate Modes)**

Symbol	Parameters	Conditions (see Notes 3, 4)	Min	Typ	Max	Unit
VBOD or VBOD- ( see <b>Note 1</b> )	BOD33 threshold level Hysteresis OFF or BOD33 threshold level Hysteresis ON	LEVEL[7:0] = 0x00 (min)	1.39	1.510	1.62	V
		LEVEL[7:0]= 0x19 (recommended value)	1.52	1.659	1.79	
		LEVEL[7:0] = 0x1C (fuse value)	1.54	1.677	1.80	
		LEVEL[7:0] = 0xFF (max)	2.80	3.045	3.28	
VBOD+ (see <b>Note 2</b> )	BOD33 threshold level Hysteresis ON at power voltage rising	LEVEL[7:0] = 0x00 (min)	1.40	1.522	1.63	
		LEVEL[7:0]= 0x19 (recommended value)	1.54	1.672	1.80	
		LEVEL[7:0] = 0x1C (fuse value)	1.56	1.690	1.82	
		LEVEL[7:0] = 0xFF (max)	2.80	3.045	3.28	

**Note:**

1.  $VBOD = VBOD- = 1.5 + LEVEL[7:0] * Level\_Step$  LEVEL[7:0] is calibration setting bus of threshold level.
2.  $VBOD+ = VBOD- + N * HYST\_STEP$  N = 0 to 15 according to HYST[3:0] value HYST\_STEP = Level\_Step.
3. Hysteresis OFF mode, HYST[3:0] = 0x0.
4. Hysteresis ON mode, HYST[3:0] = 0x1 to 0xf; Min/Typ/Max values given for 0x2.
5. At the upper side of LEVEL[7:0] values depending on the Hysteresis value chosen with HYST[3:0], the VBOD+ level reaches an overflow, e.g., for HYST[3:0] = 0d2 the hysteresis is 2 x Level\_Step = 12 mV up to position 253 and position 254 to 255 above must not be used.

# SAM D5x/E5x Family Data Sheet

## Electrical Characteristics at 125°C

**Table 56-10. BOD33 Power Consumption**

Symbol	CPU Mode	Conditions	T <sub>A</sub>	Typ.	Max	Units
I <sub>DD</sub>	Active / Idle	VCC = 1.8V	Max 125°C Typ 25°C	8.52	13.9	μA
		VCC = 3.3V		10.10	16.5	
	Standby with BOD continuous normal mode	VCC = 1.8V		4.71	6.7	
		VCC = 3.3V		6.01	8.6	
	Standby with BOD continuous low power mode or Hibernate mode	VCC = 1.8V		0.15	0.27	
		VCC = 3.3V		0.21	0.35	

### 56.6.3 Analog-to-Digital Converter (ADC) Characteristics (125°C)

Analog-to-Digital Converter conditions table is the same as 105°C.

**Table 56-11. Differential Mode <sup>(1)</sup>**

Symbol	Parameter	Conditions	Measurement			Unit	
			Min	Typ	Max		
ENOB	Effective Number of bits	Fadc = 1Msps - R2R disabled	Vddana=3.0V Vref=Vddana	10.5	10.8	11.2	bits
			Vddana=3.0V ExtVref=2.0V	10.5	10.8	11.0	
TUE	Total Unadjusted Error <sup>(3)</sup>	Fadc = 1Msps - R2R disabled	Vddana=3.0V Vref=Vddana	-	+/-2.3	+/-5.2	LSB
			Vddana=3.0V ExtVref=2.0V	-	+/-2.7	+/-5.8	
INL	Integral Non Linearity	Fadc = 1Msps - R2R disabled	Vddana=3.0V Vref=Vddana	-	+/-1.2	+/-1.8	LSB
			Vddana=3.0V ExtVref=2.0V	-	+/-1.2	+/-1.9	
DNL	Differential Non Linearity	Fadc = 1Msps - R2R disabled	Vddana=3.0V Vref=Vddana	-	+/-0.98	-1/+1	LSB
			Vddana=3.0V ExtVref=2.0V	-	+/-0.96	-1/+1.2	
Gain	Gain Error with REFCTRL.REFCOMP=1	Fadc = 1Msps	Vddana=3.0V Vref=Vddana	-0.21	-0.02	+0.2	%
			Vddana=3.0V ExtVref=2.0V	-0.13	+0.03	+0.21	
			Vddana=3.0V 1V internal Ref	-10	-1	+6.7	
			Vddana=3.0V Vref=Vddana/2	-0.48	+0.2	+0.75	
Gain	Gain Error with REFCTRL.REFCOMP=0	Fadc = 1Msps	Vddana=3.0V Vref=Vddana	-0.3	-0.001	+0.2	mV
			Vddana=3.0V ExtVref=2.0V	-0.94	-0.05	+0.71	
			Vddana=3.0V 1V internal Ref	-10	-1	+6.7	
			Vddana=3.0V Vref=Vddana/2	-1.2	+0.11	+1.28	
Offset	Offset Error with SAMPCTRL.OFFCOMP=1	Fadc = 1Msps	Vddana=3.0V Vref=Vddana	-3.6	-0.24	+3.1	%
			Vddana=3.0V ExtVref=2.0V	-3.3	-0.2	+2.7	
			Vddana=3.0V 1V internal Ref	-3.6	-0.2	+2.9	
			Vddana=3.0V Vref=Vddana/2	-3.6	-0.34	+3.3	
Offset	Offset Error with SAMPCTRL.OFFCOMP=0	Fadc = 1Msps	Vddana=3.0V Vref=Vddana	-11.9	+0.03	+/-12.3	mV
			Vddana=3.0V ExtVref=2.0V	-12.2	-0.03	+12.4	
			Vddana=3.0V 1V internal Ref	-14.3	+0.5	+14.7	
			Vddana=3.0V Vref=Vddana/2	-13.6	+0.5	+14	
SFDR	Spurious Free Dynamic Range	Fs = 1Msps Fin = 14kHz <sup>(2)</sup>	Vddana=3.0V Vref=Vddana	76.6	79.6	83.5	dB
SINAD	Signal to Noise and Distortion ratio			65.3	67.2	68.9	
SNR	Signal to Noise ratio			64.7	66.5	68.2	
THD	Total Harmonic Distortion			-91.6	-82.9	-78.3	
Nrms	Noise RMS	constant input voltage	Vddana=3.0V ExtVref=2.0V	0.2	0.4	2.4	mV
			Vddana=3.0V Vref=Vddana	0.15	0.25	2.5	

# SAM D5x/E5x Family Data Sheet

## Electrical Characteristics at 125°C

**Note:**

1. These values are based on characterization. These values are not covered by test limits in production.
2. All values expressed in decibel refer to the full scale input and are tested with an input signal 0.35dB below full scale; THD measured on the first seven harmonics of the input signal.
3. With REFCTRL.REFCOMP=1 and SAMPCTRL.OFFCOMP=1.

**Table 56-12. Single Ended Mode <sup>(1)</sup>**

Symbol	Parameter	Conditions		Measurement			Unit
				Min	Typ	Max	
ENOB	Effective Number of bits	Fadc = 1Msps - R2R disabled	Vddana=3.0V Vref=Vddana	8.9	9.25	9.9	bits
			Vddana=3.0V ExtVref=2.0V	8.9	9.5	9.7	
TUE	Total Unadjusted Error <sup>(3)</sup>	Fadc = 1Msps - R2R disabled	Vddana=3.0V Vref=Vddana	-	+/-10.9	+/-21	LSB
			Vddana=3.0V ExtVref=2.0V	-	+/-10.5	+/-19.7	
INL	Integral Non Linearity	Fadc = 1Msps - R2R disabled	Vddana=3.0V Vref=Vddana	-	+/-2.3	+/-3.2	LSB
			Vddana=3.0V ExtVref=2.0V	-	+/-2.3	+/-3.9	
DNL	Differential Non Linearity	Fadc = 1Msps - R2R disabled	Vddana=3.0V Vref=Vddana	-	+/-0.99	-1/+1	LSB
			Vddana=3.0V ExtVref=2.0V	-	+/-0.98	-1/+1.5	
Gain	Gain Error with REFCTRL.REFCOMP=1	Fadc = 1Msps	Vddana=3.0V Vref=Vddana	-0.3	-0.01	+0.3	%
			Vddana=3.0V ExtVref=2.0V	-0.16	+0.02	+0.3	
			Vddana=3.0V 1V internal Ref	-11	-1.1	+7	
			Vddana=3.0V Vref=Vddana/2	-0.5	+0.13	+0.7	

# SAM D5x/E5x Family Data Sheet

Electrical Characteristics at 125°C

.....continued							
Symbol	Parameter	Conditions		Measurement			Unit
				Min	Typ	Max	
Offset	Offset Error with SAMPCTRL.OFFCOMP=1	Fadc = 1Msps	Vddana=3.0V Vref=Vddana	-21	-7.2	+9.3	mV
			Vddana=3.0V ExtVref=2.0V	-21	-3.3	+17	
			Vddana=3.0V 1V internal Ref	-25	-4.2	+26	
			Vddana=3.0V Vref=Vddana/2	-27	-3.1	+24	
SFDR	Spurious Free Dynamic Range	Fs = 1Msps Fin = 14kHz (2)	Vddana=3.0V Vref=Vddana	67.9	69.2	76.3	dB
SINAD	Signal to Noise and Distortion ratio			55.6	57.5	61.1	
SNR	Signal to Noise ratio			54.7	56.9	60.6	
THD	Total Harmonic Distortion			-73.7	-68.2	-65.8	
Nrms	Noise RMS	constant input voltage	Vddana=3.0V ExtVref=2.0V	0.3	1.0	2.3	mV
			Vddana=3.0V Vref=Vddana	0.1	0.35	2.45	

**Note:**

1. These values are based on characterization. These values are not covered by test limits in production.
2. All values expressed in decibel refer to the full scale input and are tested with an input signal 0.35dB below full scale; THD measured on the first seven harmonics of the input signal.
3. With REFCTRL.REFCOMP=1 and SAMPCTRL.OFFCOMP=1.



# SAM D5x/E5x Family Data Sheet

## Electrical Characteristics at 125°C

**Table 56-13. Power Consumption**

Symbol	Parameters	Conditions	Ta	Typ.	Max	Units
I <sub>DD</sub> V <sub>DDANA</sub>	Differential mode	fs = 1 Msps / Reference buffer disabled / BIASREFBUF = '111', BIASREFCOMP = '111' V <sub>DDANA</sub> = V <sub>REF</sub> = 3.0V	Max 125°C Typ 25°C	279	848	μA
		fs = 1 Msps / Reference buffer enabled / BIASREFBUF = '111', BIASREFCOMP = '111' V <sub>DDANA</sub> = V <sub>REF</sub> = 3.0V		482	1381	
		fs = 10 ksps / Reference buffer disabled / BIASREFBUF = '111', BIASREFCOMP = '111' V <sub>DDANA</sub> = V <sub>REF</sub> = 3.0V		28	91	
		fs = 10 ksps / Reference buffer enabled / BIASREFBUF = '111', BIASREFCOMP = '111' V <sub>DDANA</sub> = V <sub>REF</sub> = 3.0V		241	807	
	Single Ended mode	fs = 1 Msps / Reference buffer disabled / BIASREFBUF = '111', BIASREFCOMP = '111' V <sub>DDANA</sub> = V <sub>REF</sub> = 3.0V	Max 125°C Typ 25°C	307	820	
		fs = 1 Msps / Reference buffer enabled / BIASREFBUF = '111', BIASREFCOMP = '111' V <sub>DDANA</sub> = V <sub>REF</sub> = 3.0V		499	1156	
		fs = 10 ksps / Reference buffer disabled / BIASREFBUF = '111', BIASREFCOMP = '111' V <sub>DDANA</sub> = V <sub>REF</sub> = 3.0V		38	108	
		fs = 10 ksps / Reference buffer enabled / BIASREFBUF = '111', BIASREFCOMP = '111' V <sub>DDANA</sub> = V <sub>REF</sub> = 3.0V		245	881	

### 56.6.4 Digital-to-Analog Converter (DAC) Characteristics (125°C)

**Table 56-14. Differential Mode <sup>(1)</sup>**

Symbol	Parameters	Conditions	Min.	Typ.	Max.	Unit
INL	Integral Non Linearity, Best-fit curve from 0x080 to 0xF7F	i12clk = 12 MHz, V <sub>DDANA</sub> = 3.0V, External Ref. = 2.0V, C <sub>LOAD</sub> = 50 pF	-	±2.4	±4.1	LSB
		i12clk = 12 MHz, V <sub>DDANA</sub> = 3.0V, Internal Ref, C <sub>LOAD</sub> = 50 pF	-	±3.2	±4.2	
DNL	Differential Non Linearity, Best-fit curve from 0x080 to 0xF7F	i12clk = 12 MHz, V <sub>DDANA</sub> = 3.0V, External Ref. = 2.0V, C <sub>LOAD</sub> = 50 pF	-	±2.4	±4.5	LSB
		i12clk = 12 MHz, V <sub>DDANA</sub> = 3.0V, Internal Ref, C <sub>LOAD</sub> = 50 pF	-	±3.5	±5.4	
Gerr	Gain Error	External Reference voltage	-	±0.4	±1.9	% FSR
		1.0V Internal Reference voltage	-	±0.8	±8.5	

# SAM D5x/E5x Family Data Sheet

## Electrical Characteristics at 125°C

.....continued

Symbol	Parameters	Conditions	Min.	Typ.	Max.	Unit
Offerr	Offset Error	External Reference voltage	-	±13	±47	mV
		1.0V Internal Reference voltage	-	±8	±79	
ENOB	Effective Number of Bits	Fs = 1Ms/s - External Ref - CCTRL=0x2	9.9	10.7	10.9	dB
SNR	Signal to Noise ratio		63.5	68.6	72.6	
THD	Total Harmonic Distortion		-79.1	-72.5	-61.0	

**Note:**

1. These values are based on characterization. These values are not covered by test limits in production.

**Table 56-15. Single-Ended Mode <sup>(1)</sup>**

Symbol	Parameters	Conditions	Min.	Typ.	Max.	Unit
INL	Integral Non Linearity, Best-fit curve from 0x080 to 0xF7F	i12clk = 12 MHz, V <sub>DDANA</sub> = 3.0V External Ref. = 2.0V, C <sub>LOAD</sub> = 50 pF	-	±2.7	±6.0	LSB
		i12clk = 12 MHz V <sub>DDANA</sub> = 3.0V, Internal Ref, C <sub>LOAD</sub> = 50 pF	-	±5.2	±11.2	
DNL	Differential Non Linearity, Best-fit curve from 0x080 to 0xF7F	i12clk = 12 MHz, V <sub>DDANA</sub> = 3.0V External Ref = 2.0V, C <sub>LOAD</sub> = 50 pF	-	±3.5	±8.1	LSB
		i12clk = 12 MHz V <sub>DDANA</sub> = 3.0V, Internal Ref, C <sub>LOAD</sub> = 50 pF	-	±6.4	±12.1	
Gerr	Gain Error	External Reference voltage	-	±0.3	±1.6	% FSR
		1.0V Internal Reference voltage	-	±0.8	±8.6	
Offerr	Offset Error	External Reference voltage	-	±7	±25.5	mV
		1.0V Internal Reference voltage	-	±2	±19	
ENOB	Effective Number of Bits	Fs = 1Ms/s - External Ref - CCTRL=0x2	9.1	10.3	10.7	dB
SNR	Signal to Noise ratio		63.5	68.6	72.6	
THD	Total Harmonic Distortion		-79.1	-72.8	-61.0	

**Note:**

1. These values are based on characterization. These values are not covered by test limits in production.

# SAM D5x/E5x Family Data Sheet

## Electrical Characteristics at 125°C

**Table 56-16. Power Consumption**

Symbol	Parameters	Conditions	Ta	Min.	Typ.	Max.	Unit
I <sub>DDANA</sub>	Differential Mode, DC supply current, 2 output channels - without load	fs = 1 Msps, CCTRL L= 0x2, V <sub>REF</sub> > 2.4V, V <sub>CC</sub> = 3.3V	Max. 125°C Typ. 25°C	-	384	634	μA
		fs = 10 ksps, CCTRL = 0x0, V <sub>REF</sub> < 2.4V, V <sub>CC</sub> = 3.3V		-	283	482	
	Single-Ended Mode, DC supply current, 2 output channels - without load	fs = 1 Msps, CCTRL = 0x2, V <sub>REF</sub> > 2.4V, V <sub>CC</sub> = 3.3V		-	306	517	μA
		fs = 10 ksps, CCTRL = 0x0, V <sub>REF</sub> < 2.4V, V <sub>CC</sub> = 3.3V		-	230	389	

### 56.6.5 Analog Comparator (AC) Characteristics (125°C)

**Table 56-17. Analog Comparator Characteristics**

Symbol	Parameters	Conditions	Min	Typ	Max	Unit
Off <sup>(1)</sup>	Offset	High speed COMPCTRLn.SPEED = 0x3	-22	±3	22	mV
T <sub>pd</sub>	Propagation Delay V <sub>cm</sub> =V <sub>ddana</sub> /2, V <sub>in</sub> = +/-100mV overdrive from V <sub>cm</sub>	High speed COMPCTRLn.SPEED = 0x3	-	24.1	42	ns
T <sub>start</sub>	Startup time	High speed COMPCTRLn.SPEED = 0x3	-	4.7	8	μs

**Note:**

1. Hysteresis disabled.

**Table 56-18. Power Consumption**

Symbol	Parameters	Conditions	Ta	Typ.	Max.	Unit
I <sub>DDANA</sub>	Current consumption for One AC enabled, Hysteresis disabled voltage scaler disabled	COMPCTRLn.SPEED=0x3, V <sub>DDANA</sub> =3.3V	Max.125°C Typ.25°C	59	106	μA
	Current consumption Voltage Scaler only	V <sub>DDANA</sub> =3.3V		11	23.3	

### 56.6.6 PTC Characteristics

The values in the following Power Consumption table are measured values of power consumption under the following conditions:

**Operating Conditions:**

VDD = 3.0V

**Clocks**

DFLL48M used as main clock source, running undivided at 48 MHz

# SAM D5x/E5x Family Data Sheet

## Electrical Characteristics at 125°C

CPU is running on Flash with 2 wait states, at 48 MHz

PTC running at 4 MHz

### PTC Configuration

Mutual Capacitance mode

One touch channel

### System Configuration

Standby Sleep mode enabled

RTC running on ULP32K: used to define the PTC scan rate, through the event system

RTC interrupts (wake up) the CPU to perform PTC scans

**Table 56-19. Power Consumption <sup>(1)</sup>**

Symbol	Parameters	PTC scan rate (msec)	Oversamples	T <sub>A</sub>	Typ.	Max.	Units
IDD	Current Consumption	10	4	Max. 125°C Typ 25°C	137	3960	μA
			16		146	3989	
		50	4		77	3882	
			16		79	3893	
		100	4		68	3877	
			16		69	3885	
		200	4		64	3870	
			16		65	3872	

#### Note:

1. These values are based on characterization.

## 56.7 NVM Characteristics (125°C)

**Table 56-20. NVM Flash Read Wait States for Worst Case Conditions**

CPU Fmax (MHz)	0 WS	1 WS	2 WS	3 WS	4 WS	5 WS	6 WS	Auto WS
Read Operations	1 cycle	2 cycles	3 cycles	4 cycles	5 cycles	6 cycles	7 cycles	n cycles
VDD > 1.71V	19	38	57	76	95	100	100	100

Maximum operating frequencies are given in the table above, but are limited by the Embedded Flash access time when the processor is fetching code out of it. These tables provide the device maximum operating frequency defined by the field RWS of the NVMCTRL CTRLA register when automatic wait states (AUTOWS) is disabled. This field defines the number of Wait states required to access the Embedded Flash Memory.

# SAM D5x/E5x Family Data Sheet

## Electrical Characteristics at 125°C

### 56.8 Oscillators Characteristics (125°C)

#### 56.8.1 Crystal Oscillator (XOSC) Characteristics (125°C)

Table 56-21. Multiple Crystal Oscillator Characteristics

Symbol	Parameter	Conditions	Min.	Typ.	Max	Units
Tstart	Startup time	F = 8MHz - CL=20 pF - Cshunt = 2 pF - IMULT=0x3	-	39700	72200	Cycles
		F = 16MHz - CL=20 pF - Cshunt = 1,5 pF - IMULT=0x4	-	37550	73000	
		F = 24MHz - CL=20 pF - Cshunt = 2,5 pF - IMULT=0x5	-	32700	71000	
		F = 48MHz - CL=13 pF - Cshunt = 5 pF - IMULT=0x6	-	18400	38500	

Table 56-22. Power Consumption

Symbol	Parameters	Conditions	Ta	Typ.	Max.	Units
I <sub>DD</sub>	Current Consumption	F = 8 MHz - C <sub>L</sub> = 20 pF - IMULT = 0x3, ENALC = OFF	Max. 125°C, Typ. 25°C	0.43	2.27	mA
		ENALC = ON		0.16	1.87	
		F = 16 MHz - C <sub>L</sub> = 20 pF - IMULT = 0x5, ENALC = OFF		1.31	3.72	
		ENALC = ON		0.25	2.23	
		F = 32 MHz - C <sub>L</sub> = 13 pF - IMULT = 0x5, ENALC = OFF		2.92	6.49	
		ENALC = ON		0.40	2.43	
		F = 48 MHz - C <sub>L</sub> = 13 pF - IMULT = 0x6, ENALC = OFF		2.70	6.71	
		ENALC = ON		0.76	3.52	

#### 56.8.2 External 32 kHz Crystal Oscillator (XOSC32K) Characteristics (125°C)

Table 56-23. 32 kHz Crystal Oscillator Electrical Characteristics

Symbol	Parameter	Conditions	Min.	Typ.	Max.	Units
t <sub>STARTUP</sub>	Startup time	f=32.768 kHz, C <sub>L</sub> =12.5 pF, C <sub>M</sub> =2.0 fF	-	12	32	kCycles

# SAM D5x/E5x Family Data Sheet

## Electrical Characteristics at 125°C

**Table 56-24. Power Consumption**

Symbol	Parameter	Conditions	Ta	Gain Mode	Typ.	Max.	Units
I <sub>DD</sub>	Current consumption	VDD=3.0V	Max 125°C Typ 25°C	Std.	1.5	2.6	μA
				High	1.9	3.4	

### 56.8.3 Internal Ultra Low Power 32 kHz RC Oscillator (OSCULP32K) Characteristics (125°C)

**Table 56-25. Ultra-Low-Power Internal 32 kHz RC Oscillator Electrical Characteristics**

Symbol	Parameter	Calibration	Conditions	Min.	Typ.	Max	Units
F <sub>OUT</sub>	Output frequency	Factory default & without user software calibration	[-40, +125]°C, VDDANA>1.71V	26.00	32.768	40.92	kHz
			Recalibrate using XOOSC as reference Clock source	32.28		33.4	
			Recalibrate using DFLL as reference Clock source	31.29		34.24	

### 56.8.4 Digital Frequency Locked Loop (DFLL48M) Characteristics (125°C)

**Table 56-26. DFLL48M Characteristics - Open Loop Mode <sup>(1)</sup>**

Symbol	Parameter	Conditions	Min.	Typ.	Max.	Units
F <sub>OpenOUT</sub>	Output frequency	DFLLVAL after Reset LDO Regulator mode, [-40, 125]°C	45.57	48	50.63	MHz
		DFLLVAL after Reset LDO Regulator mode, [0, 60]°C	47.12	48	48.9	

**Note:**

- DFLL48 in open loop can be used only with LDO regulator.

**Table 56-27. DFLL48M Power Consumption**

Symbol	Parameter	Conditions	Ta	Min.	Typ.	Max.	Units
I <sub>DD</sub>	Current Consumption	Open Loop mode - DFLLVAL after reset VCC = 3.3V	Max. 125°C Typ. 25°C	-	400	2129	μA
		Closed Loop mode - f <sub>REF</sub> = 32.768 kHz VCC = 3.3V		-	404	2113	

# SAM D5x/E5x Family Data Sheet

## Electrical Characteristics at 125°C

### 56.8.5 Fractional Digital Phase Lock Loop (FDPLL) Characteristics (125°C)

Table 56-28. Fractional Digital Phase Lock Loop Characteristics <sup>(1)</sup>

Symbol	Parameter	Conditions	Min.	Typ.	Max.	Units
Jp	Period jitter (Peak-Peak value)	f <sub>IN</sub> = 32 kHz, f <sub>OUT</sub> = 96 MHz	-	1.9	3.0	%
		f <sub>IN</sub> = 32 kHz, f <sub>OUT</sub> = 200 MHz	-	3.4	6.0	
		f <sub>IN</sub> = 3.2 MHz, f <sub>OUT</sub> = 96 MHz	-	2.0	3.1	
		f <sub>IN</sub> = 3.2 MHz, f <sub>OUT</sub> = 200 MHz	-	4.3	7.2	

**Note:**

1. These FDPLL200M characteristics are applicable with LDO regulator and a direct reference (i.e., REFCLK is XOSC or XOSC32K, not GCLK).

Table 56-29. Power Consumption

Symbol	Parameter	Conditions	TA	Typ.	Max.	Units
I <sub>DD</sub>	Current Consumption	Ck = 96 MHz, VDD = 3.3V	Max. 125°C Typ. 25°C	0.9	2.5	mA
		Ck = 200 MHz, VDD = 3.3V		2.0	3.4	

### 56.9 Timing Characteristics (125°C)

#### 56.9.1 SERCOM in SPI Mode Timing (125°C)

Table 56-30. SPI Timing Characteristics and Requirements<sup>(1)</sup>

Symbol	Parameter	Conditions	Min.	Typ.	Max.	Units
t <sub>MIS</sub>	MISO setup to SCK	Master, VDD>2.70V	19.5	-	-	ns
		Master, VDD>1.71V	20	-	-	
t <sub>SOV</sub>	MISO output valid SCK	Slave, VDD>2.70V	16.5	-	-	ns
		Slave, VDD>1.71V	25	-	-	

1. These values are based on simulation, with capacitance load between 5pF and 20pF. These values are not covered by test limits in production.

**57. AEC Q-100 Grade 1, 125°C Electrical Characteristics**



**Important:** AEC-Q100 Grade 1 Electrical Specifications are covered by [Electrical Characteristics at 125°C](#) unless explicitly mentioned in this document.

---



## 58. Packaging Information

### 58.1 Package Marking Information

All devices are marked with Atmel logo and ordering code.

Additional marking information is as follows:

- "YY": Manufacturing year
- "WW": Manufacturing week
- "R": Internal Code
- "XXXXXX": Lot number



## 58.2 Thermal Considerations

### 58.2.1 Thermal Resistance Data

The following table summarizes the thermal resistance data depending on the package.

**Table 58-1. Thermal Resistance Data**

Package Type	$\theta_{JA}$	$\theta_{JC}$
64-pin TQFP	57.4°C/W	10.6°C/W
100-pin TQFP	55.0°C/W	11.1°C/W
128-pin TQFP	48.7°C/W	9.4°C/W
120-pin TFBGA	36.63°C/W	12.2°C/W
48-pin VQFN	29.8°C/W	10.0°C/W
64-pin VQFN	30.3°C/W	9.9°C/W
64-pin WLCSP	36.8°C/W	5.0°C/W

### 58.2.2 Junction Temperature

The average chip-junction temperature,  $T_J$ , in °C can be obtained from the following equations:

- **Equation 1-**  $T_J = T_A + (P_D \times \theta_{JA})$
- **Equation 2 -**  $T_J = T_A + (P_D \times (\theta_{HEATSINK} + \theta_{JC}))$

where:

- $\theta_{JA}$  = Package thermal resistance, Junction-to-ambient (°C/W), see Thermal Resistance Data
- $\theta_{JC}$  = Package thermal resistance, Junction-to-case thermal resistance (°C/W), see Thermal Resistance Data

- $\theta_{\text{HEATSINK}}$  = Thermal resistance ( $^{\circ}\text{C}/\text{W}$ ) specification of the external cooling device
- $P_{\text{D}}$  = Device power consumption (W)
- $T_{\text{A}}$  = Ambient temperature ( $^{\circ}\text{C}$ )

From the first equation, the user can derive the estimated lifetime of the chip and decide whether a cooling device is necessary or not. If a cooling device has to be fitted on the chip, the second equation must be used to compute the resulting average chip-junction temperature  $T_{\text{J}}$  in  $^{\circ}\text{C}$ .

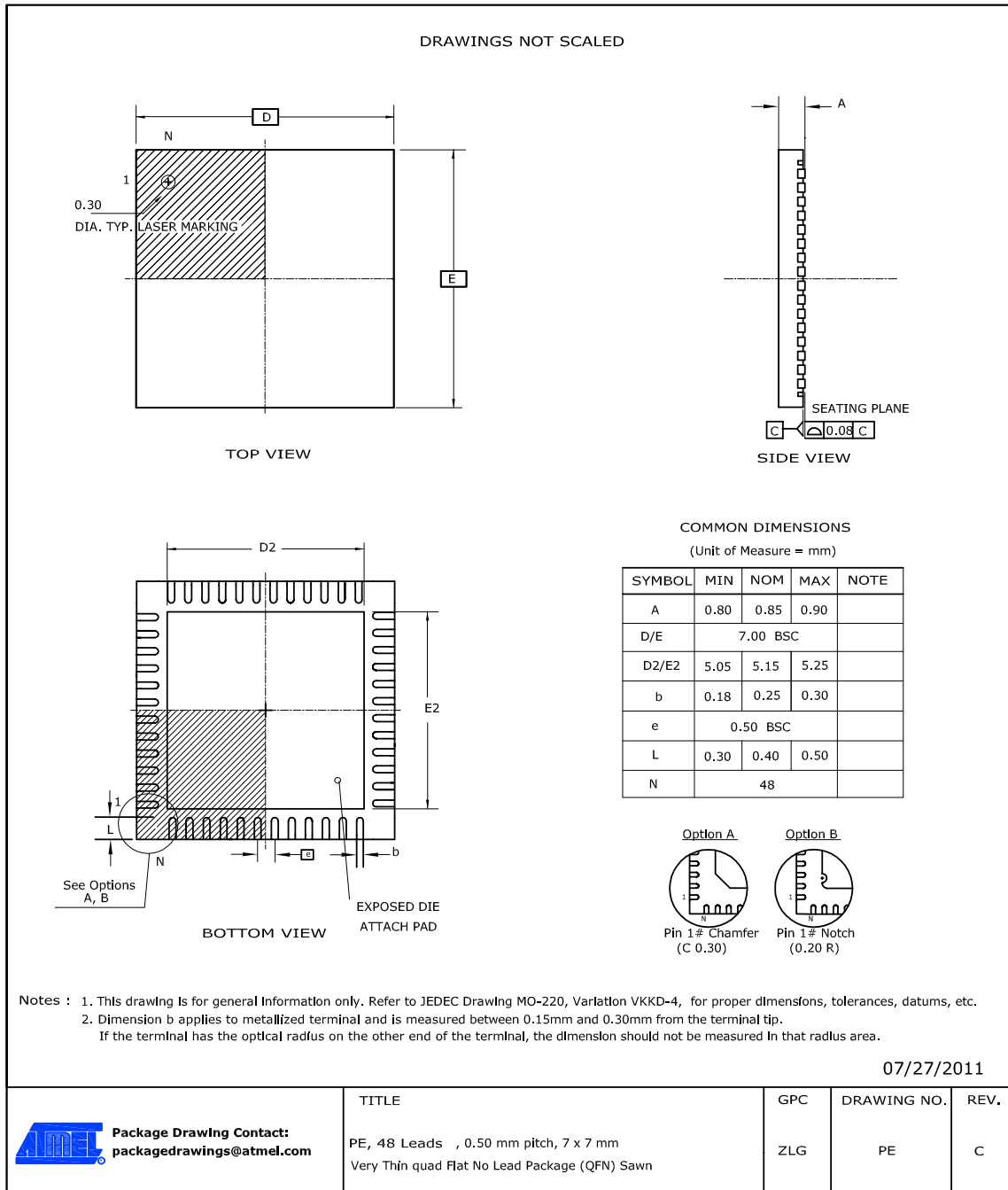
### 58.3 Package Drawings

**Note:** For current package drawings, refer to the Microchip Packaging Specification, which is available at <http://www.microchip.com/packaging>.

# SAM D5x/E5x Family Data Sheet

## Packaging Information

### 58.3.1 48-Pin VQFN



**Note:** The exposed die attach pad is not connected electrically inside the device.

**Table 58-2. Device and Package Maximum Weight**

140	mg
-----	----

**Table 58-3. Package Characteristics**

Moisture Sensitivity Level	MSL3
----------------------------	------

# SAM D5x/E5x Family Data Sheet

## Packaging Information

**Table 58-4. Package Reference**

JEDEC Drawing Reference	MO-220
JESD97 Classification	E3

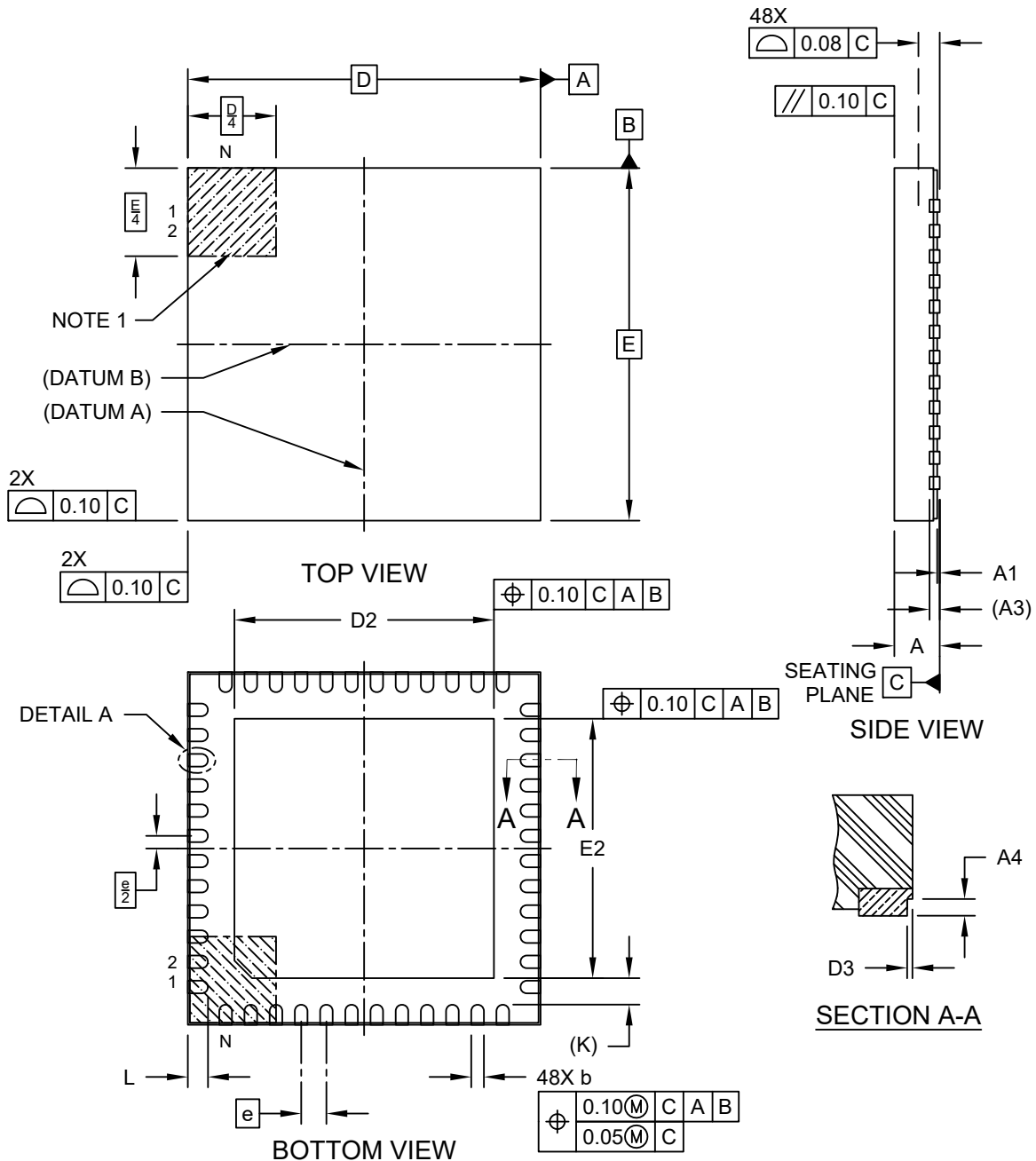
# SAM D5x/E5x Family Data Sheet

## Packaging Information

### 58.3.2 48-Pin VQFN Wettable Flanks

#### 48-Lead Very Thin Plastic Quad Flat, No Lead Package (U5B) - 7x7 mm Body [VQFN] With 5.15 mm Exposed Pad and Stepped Wettable Flanks; Atmel Legacy ZLH

**Note:** For the most current package drawings, please see the Microchip Packaging Specification located at <http://www.microchip.com/packaging>



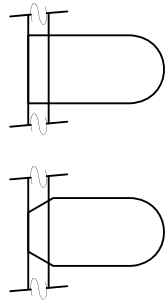
Microchip Technology Drawing C04-21493 Rev A Sheet 1 of 2

# SAM D5x/E5x Family Data Sheet

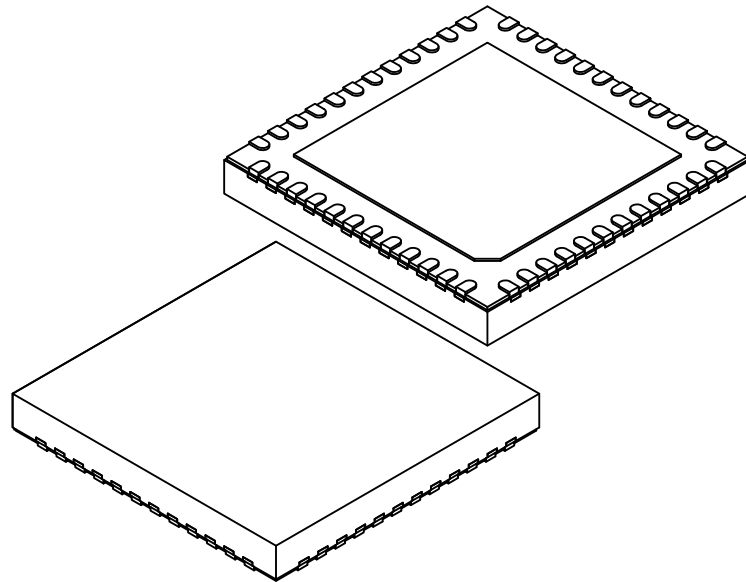
## Packaging Information

### 48-Lead Very Thin Plastic Quad Flat, No Lead Package (U5B) - 7x7 mm Body [VQFN] With 5.15 mm Exposed Pad and Stepped Wettable Flanks; Atmel Legacy ZLH

**Note:** For the most current package drawings, please see the Microchip Packaging Specification located at <http://www.microchip.com/packaging>



**DETAIL 1**  
ALTERNATE TERMINAL  
CONFIGURATIONS



Dimension Limits	Units	MILLIMETERS		
		MIN	NOM	MAX
Number of Terminals	N	48		
Pitch	e	0.50 BSC		
Overall Height	A	0.80	0.85	0.90
Standoff	A1	0.00	0.02	0.05
Terminal Thickness	A3	0.203 REF		
Overall Length	D	7.00 BSC		
Exposed Pad Length	D2	5.05	5.15	5.25
Overall Width	E	7.00 BSC		
Exposed Pad Width	E2	5.05	5.15	5.25
Terminal Width	b	0.20	0.25	0.30
Terminal Length	L	0.35	0.40	0.45
Terminal-to-Exposed-Pad	K	0.53 REF		
Wettable Flank Step Length	D3	-	-	0.085
Wettable Flank Step Height	A4	0.10	-	0.19

**Notes:**

1. Pin 1 visual index feature may vary, but must be located within the hatched area.
2. Package is saw singulated
3. Dimensioning and tolerancing per ASME Y14.5M
  - BSC: Basic Dimension. Theoretically exact value shown without tolerances.
  - REF: Reference Dimension, usually without tolerance, for information purposes only.

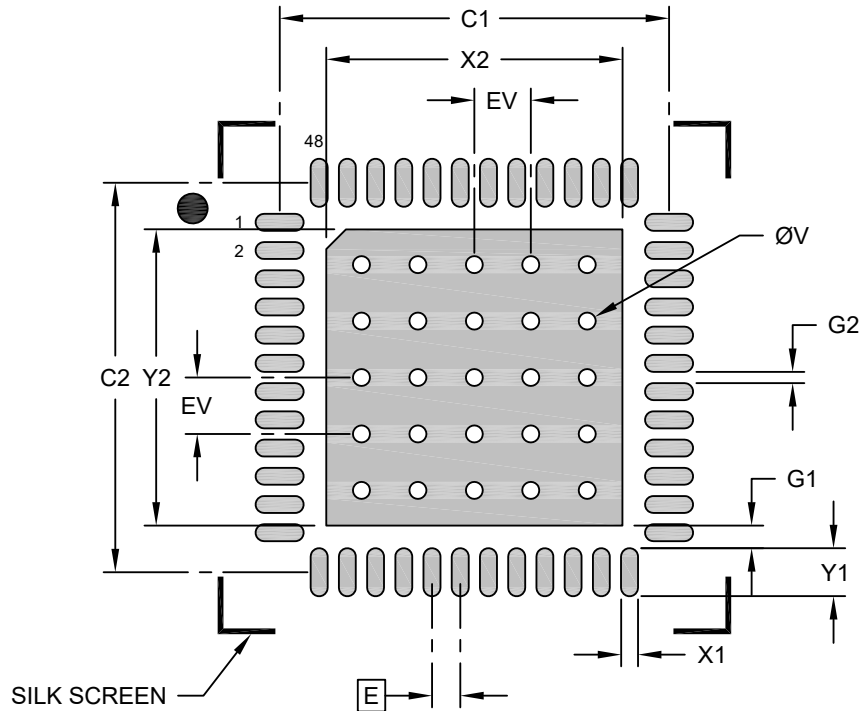
Microchip Technology Drawing C04-21493 Rev A Sheet 2 of 2

# SAM D5x/E5x Family Data Sheet

## Packaging Information

### 48-Lead Very Thin Plastic Quad Flat, No Lead Package (U5B) - 7x7 mm Body [VQFN] With 5.15 mm Exposed Pad and Stepped Wettable Flanks; Atmel Legacy ZLH

**Note:** For the most current package drawings, please see the Microchip Packaging Specification located at <http://www.microchip.com/packaging>



#### RECOMMENDED LAND PATTERN

Dimension Limits	Units	MILLIMETERS		
		MIN	NOM	MAX
Contact Pitch	E	0.50 BSC		
Optional Center Pad Width	X2			5.25
Optional Center Pad Length	Y2			5.25
Contact Pad Spacing	C1		6.90	
Contact Pad Spacing	C2		6.90	
Contact Pad Width (X48)	X1			0.30
Contact Pad Length (X48)	Y1			0.85
Contact Pad to Center Pad (X48)	G1	0.20		
Contact Pad to Center Pad (X44)	G2	0.40		
Thermal Via Diameter	V		0.30	
Thermal Via Pitch	EV		1.00	

**Notes:**

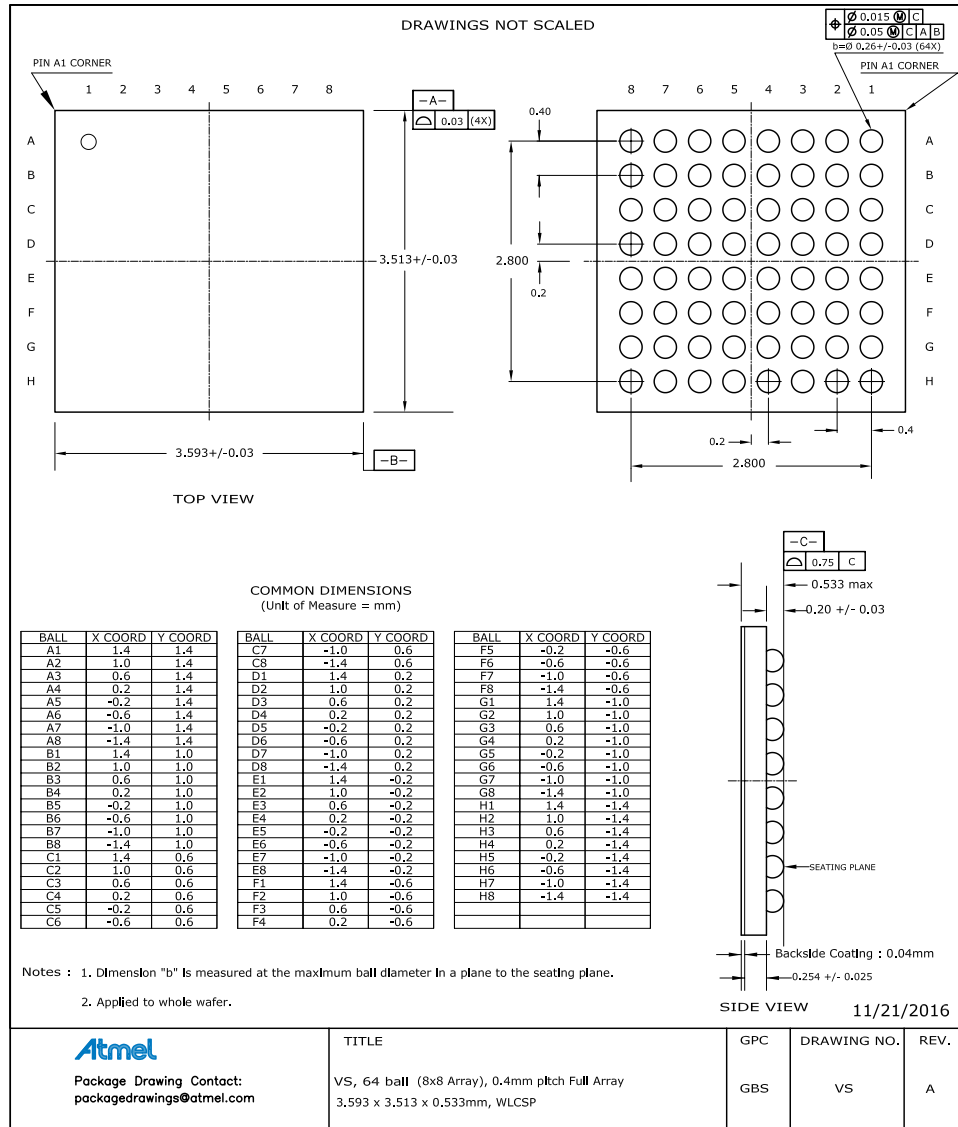
1. Dimensioning and tolerancing per ASME Y14.5M  
BSC: Basic Dimension. Theoretically exact value shown without tolerances.
2. For best soldering results, thermal vias, if used, should be filled or tented to avoid solder loss during reflow process

Microchip Technology Drawing C04-23493 Rev A

# SAM D5x/E5x Family Data Sheet

## Packaging Information

### 58.3.3 64-Ball WLCSP





# SAM D5x/E5x Family Data Sheet

## Packaging Information

**Table 58-5. Device and Package Maximum Weight**

14	mg
----	----

**Table 58-6. Package Characteristics**

Moisture Sensitivity Level	MSL1
----------------------------	------

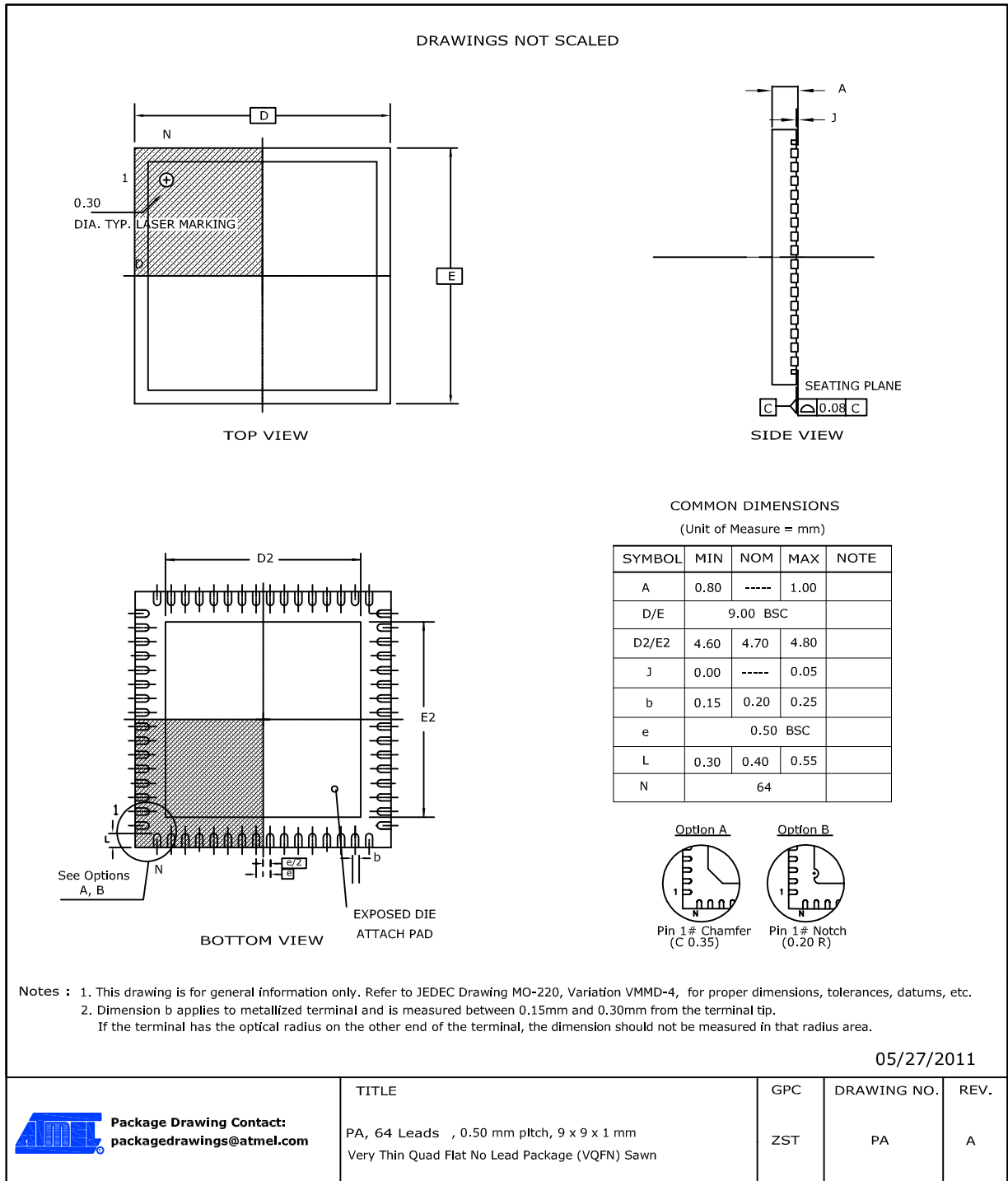
**Table 58-7. Package Reference**

JEDEC Drawing Reference	N/A
JESD97 Classification	e1

# SAM D5x/E5x Family Data Sheet

## Packaging Information

### 58.3.4 64-Pin VQFN



**Note:** The exposed die attach pad is not connected electrically inside the device.

**Table 58-8. Device and Package Maximum Weight**

200	mg
-----	----

# SAM D5x/E5x Family Data Sheet

## Packaging Information

**Table 58-9. Package Characteristics**

Moisture Sensitivity Level	MSL3
----------------------------	------

**Table 58-10. Package Reference**

JEDEC Drawing Reference	MO-220
JESD97 Classification	E3

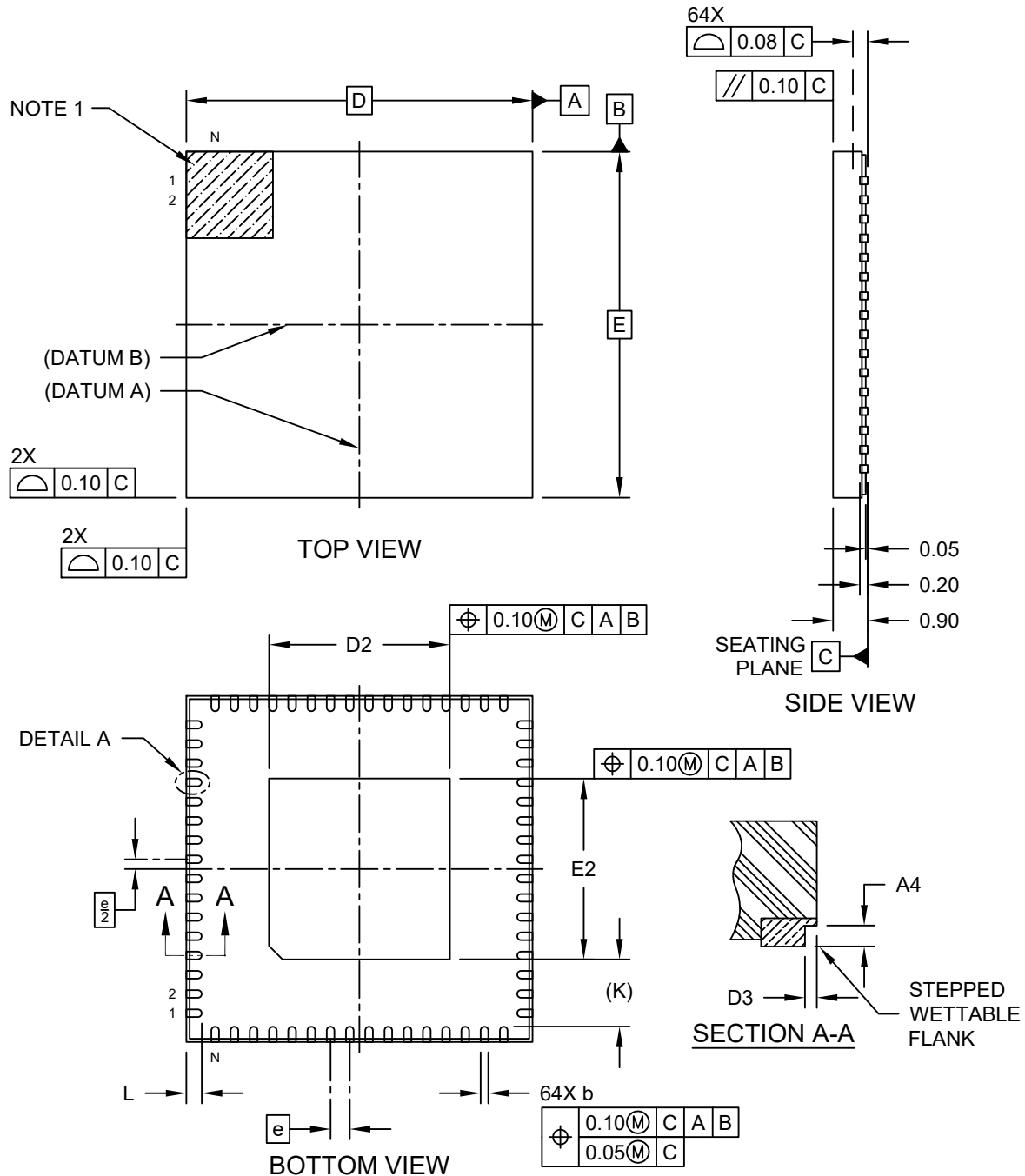
# SAM D5x/E5x Family Data Sheet

## Packaging Information

### 58.3.5 64-Pin VQFN Wettable Flanks

#### 64-Lead Very Thin Plastic Quad Flat, No Lead Package (U6B) - 9x9 mm Body [VQFN] With 4.7 mm Exposed Pad and Stepped Wettable Flanks; Atmel Legacy ZRB

**Note:** For the most current package drawings, please see the Microchip Packaging Specification located at <http://www.microchip.com/packaging>



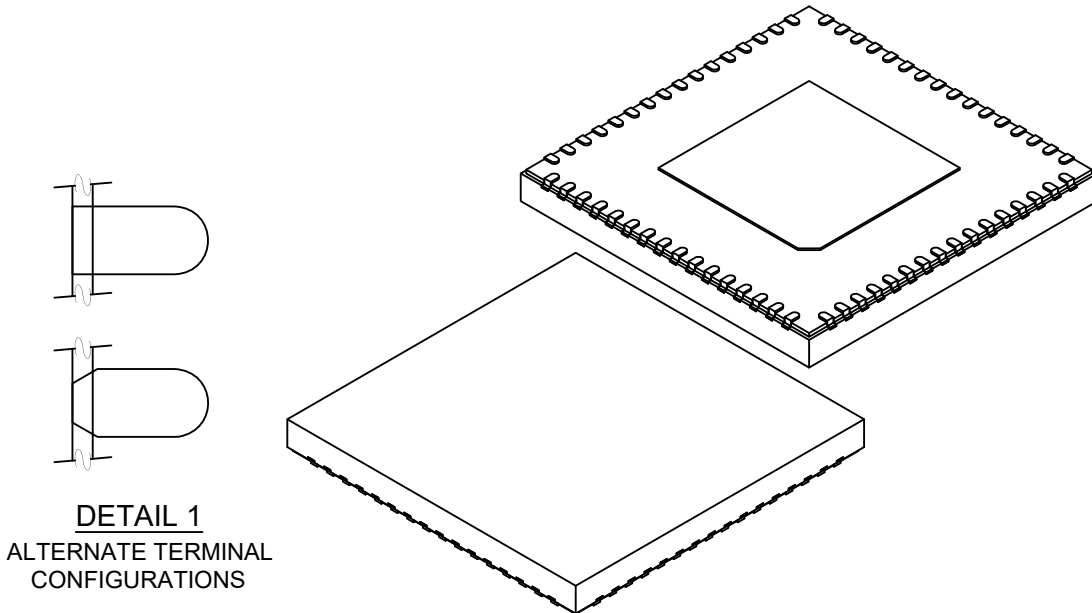
Microchip Technology Drawing C04-21497 Rev A Sheet 1 of 2

# SAM D5x/E5x Family Data Sheet

## Packaging Information

### 64-Lead Very Thin Plastic Quad Flat, No Lead Package (U6B) - 9x9 mm Body [VQFN] With 4.7 mm Exposed Pad and Stepped Wettable Flanks; Atmel Legacy ZRB

**Note:** For the most current package drawings, please see the Microchip Packaging Specification located at <http://www.microchip.com/packaging>



Dimension Limits	Units	MILLIMETERS		
		MIN	NOM	MAX
Number of Terminals	N	64		
Pitch	e	0.50 BSC		
Overall Height	A	0.80	0.85	0.90
Standoff	A1	0.00	0.035	0.05
Terminal Thickness	A3	0.203 REF		
Overall Length	D	9.00 BSC		
Exposed Pad Length	D2	4.60	4.70	4.80
Overall Width	E	9.00 BSC		
Exposed Pad Width	E2	4.60	4.70	4.80
Terminal Width	b	0.15	0.20	0.25
Terminal Length	L	0.35	0.40	0.45
Terminal-to-Exposed-Pad	K	1.75 REF		
Wettable Flank Step Length	D3	-	-	0.085
Wettable Flank Step Height	A4	0.10	-	0.19

**Notes:**

1. Pin 1 visual index feature may vary, but must be located within the hatched area.
2. Package is saw singulated
3. Dimensioning and tolerancing per ASME Y14.5M  
 BSC: Basic Dimension. Theoretically exact value shown without tolerances.  
 REF: Reference Dimension, usually without tolerance, for information purposes only.

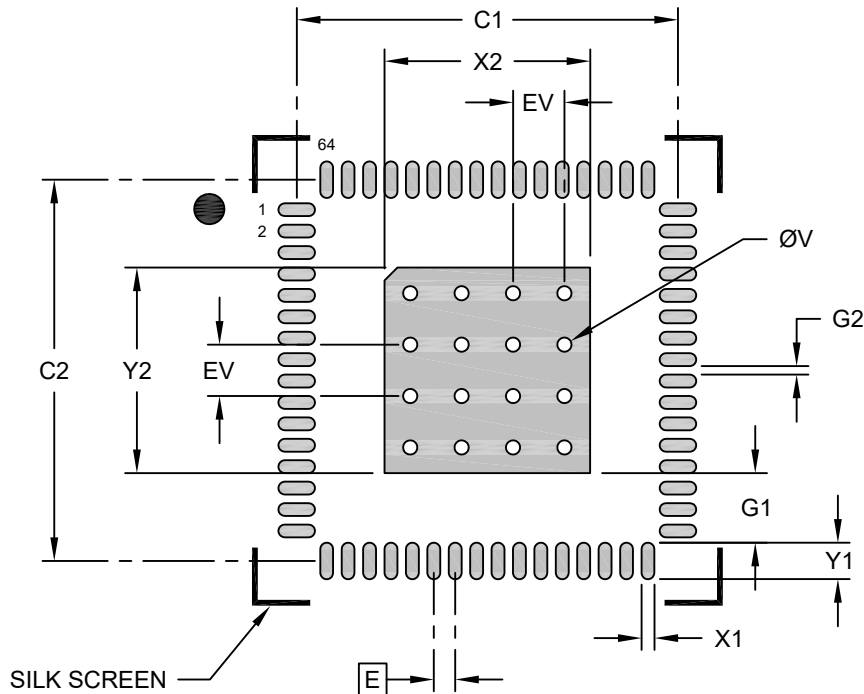
Microchip Technology Drawing C04-21497 Rev A Sheet 1 of 2

# SAM D5x/E5x Family Data Sheet

## Packaging Information

### 64-Lead Very Thin Plastic Quad Flat, No Lead Package (U6B) - 9x9 mm Body [VQFN] With 4.7 mm Exposed Pad and Stepped Wettable Flanks; Atmel Legacy ZRB

**Note:** For the most current package drawings, please see the Microchip Packaging Specification located at <http://www.microchip.com/packaging>



### RECOMMENDED LAND PATTERN

Dimension Limits	Units	MILLIMETERS		
		MIN	NOM	MAX
Contact Pitch	E	0.50 BSC		
Optional Center Pad Width	X2			4.80
Optional Center Pad Length	Y2			4.80
Contact Pad Spacing	C1		8.90	
Contact Pad Spacing	C2		8.90	
Contact Pad Width (X64)	X1			0.30
Contact Pad Length (X64)	Y1			0.85
Contact Pad to Center Pad (X64)	G1	1.63		
Contact Pad to Contact Pad (X60)	G2	0.20		
Thermal Via Diameter	V		0.33	
Thermal Via Pitch	EV		1.20	

**Notes:**

1. Dimensioning and tolerancing per ASME Y14.5M  
BSC: Basic Dimension. Theoretically exact value shown without tolerances.
2. For best soldering results, thermal vias, if used, should be filled or tented to avoid solder loss during reflow process

Microchip Technology Drawing C04-23497 Rev A

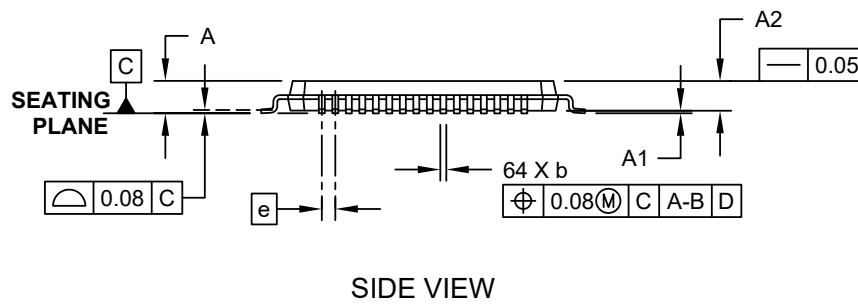
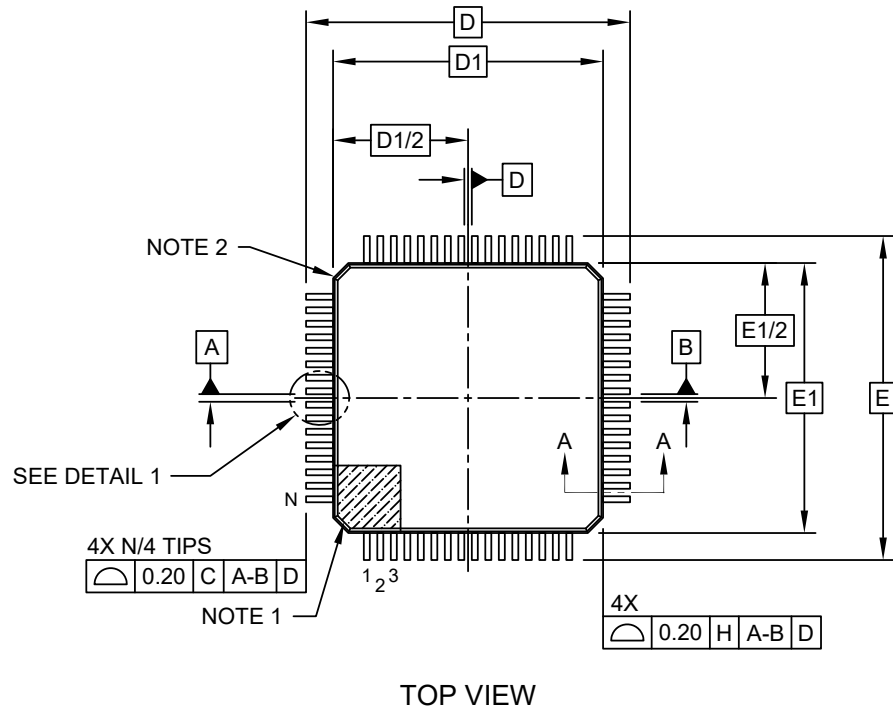
# SAM D5x/E5x Family Data Sheet

## Packaging Information

### 58.3.6 64-pin TQFP

#### 64-Lead Plastic Thin Quad Flatpack (PT)-10x10x1 mm Body, 2.00 mm Footprint [TQFP]

**Note:** For the most current package drawings, please see the Microchip Packaging Specification located at <http://www.microchip.com/packaging>



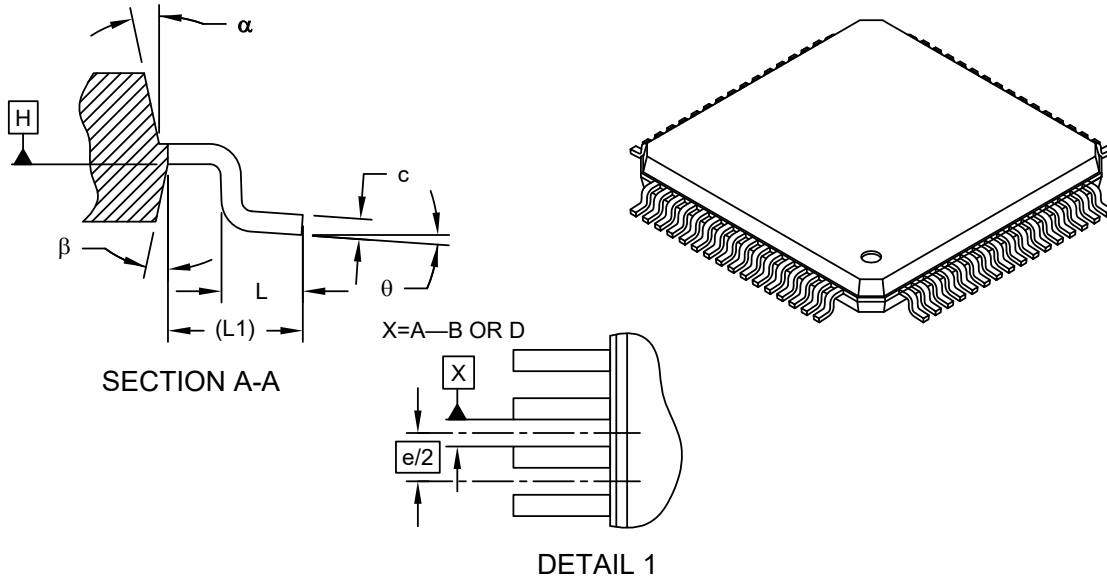
Microchip Technology Drawing C04-085C Sheet 1 of 2

# SAM D5x/E5x Family Data Sheet

## Packaging Information

### 64-Lead Plastic Thin Quad Flatpack (PT)-10x10x1 mm Body, 2.00 mm Footprint [TQFP]

**Note:** For the most current package drawings, please see the Microchip Packaging Specification located at <http://www.microchip.com/packaging>



Dimension	Units	MILLIMETERS		
		MIN	NOM	MAX
Number of Leads	N	64		
Lead Pitch	e	0.50 BSC		
Overall Height	A	-	-	1.20
Molded Package Thickness	A2	0.95	1.00	1.05
Standoff	A1	0.05	-	0.15
Foot Length	L	0.45	0.60	0.75
Footprint	L1	1.00 REF		
Foot Angle	$\phi$	0°	3.5°	7°
Overall Width	E	12.00 BSC		
Overall Length	D	12.00 BSC		
Molded Package Width	E1	10.00 BSC		
Molded Package Length	D1	10.00 BSC		
Lead Thickness	c	0.09	-	0.20
Lead Width	b	0.17	0.22	0.27
Mold Draft Angle Top	$\alpha$	11°	12°	13°
Mold Draft Angle Bottom	$\beta$	11°	12°	13°

**Notes:**

1. Pin 1 visual index feature may vary, but must be located within the hatched area.
2. Chamfers at corners are optional; size may vary.
3. Dimensions D1 and E1 do not include mold flash or protrusions. Mold flash or protrusions shall not exceed 0.25mm per side.
4. Dimensioning and tolerancing per ASME Y14.5M

BSC: Basic Dimension. Theoretically exact value shown without tolerances.

REF: Reference Dimension, usually without tolerance, for information purposes only.

Microchip Technology Drawing C04-085C Sheet 2 of 2

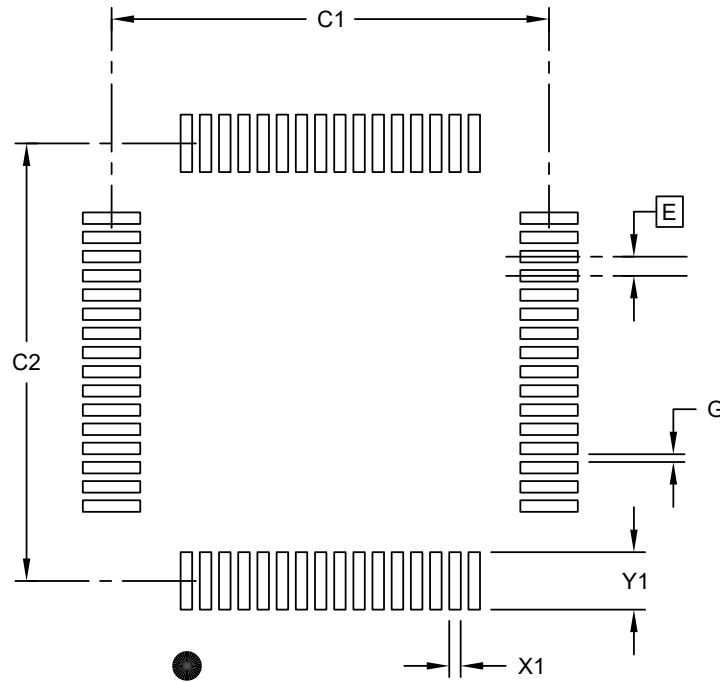


# SAM D5x/E5x Family Data Sheet

## Packaging Information

### 64-Lead Plastic Thin Quad Flatpack (PT)-10x10x1 mm Body, 2.00 mm Footprint [TQFP]

**Note:** For the most current package drawings, please see the Microchip Packaging Specification located at <http://www.microchip.com/packaging>



RECOMMENDED LAND PATTERN

Dimension Limits	Units	MILLIMETERS		
		MIN	NOM	MAX
Contact Pitch	E	0.50 BSC		
Contact Pad Spacing	C1		11.40	
Contact Pad Spacing	C2		11.40	
Contact Pad Width (X28)	X1			0.30
Contact Pad Length (X28)	Y1			1.50
Distance Between Pads	G	0.20		

**Notes:**

- Dimensioning and tolerancing per ASME Y14.5M  
BSC: Basic Dimension. Theoretically exact value shown without tolerances.

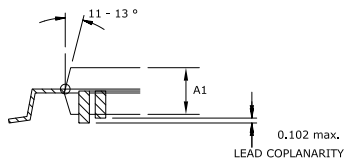
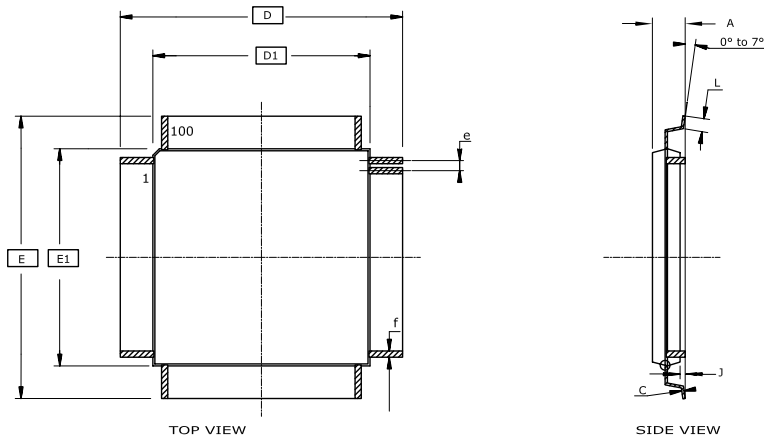
Microchip Technology Drawing C04-2085B Sheet 1 of 1

# SAM D5x/E5x Family Data Sheet

## Packaging Information

### 58.3.7 100 pin TQFP

DRAWINGS NOT SCALED



DETAIL VIEW

#### COMMON DIMENSIONS

(Unit of Measure = mm)

SYMBOL	MIN	NOM	MAX	NOTE
A	-----	----	1.20	
A1	0.95	-----	1.05	
C	0.09	-----	0.20	
D/E	16.00			
D1/E1	14.00			2
J	0.05	-----	0.15	
L	0.45	-----	0.75	
e	0.50 BSC			
f	0.17	-----	0.27	
n	100			

- Notes : 1. This drawing is for general information only. Refer to JEDEC Drawing MS-026, Variation AED.  
 2. Dimensions D1 and E1 do not include mold protrusion. Allowable protrusion is 0.25mm per side. Dimensions D1 and E1 are maximum plastic body size dimensions including mold mismatch.  
 3. Lead coplanarity is 0.10mm maximum.

**Table 58-11. Device and Package Maximum Weight**

520	mg
-----	----

**Table 58-12. Package Characteristics**

Moisture Sensitivity Level	MSL3
----------------------------	------

**Table 58-13. Package Reference**

JEDEC Drawing Reference	MS-026, variant AED
JESD97 Classification	e3

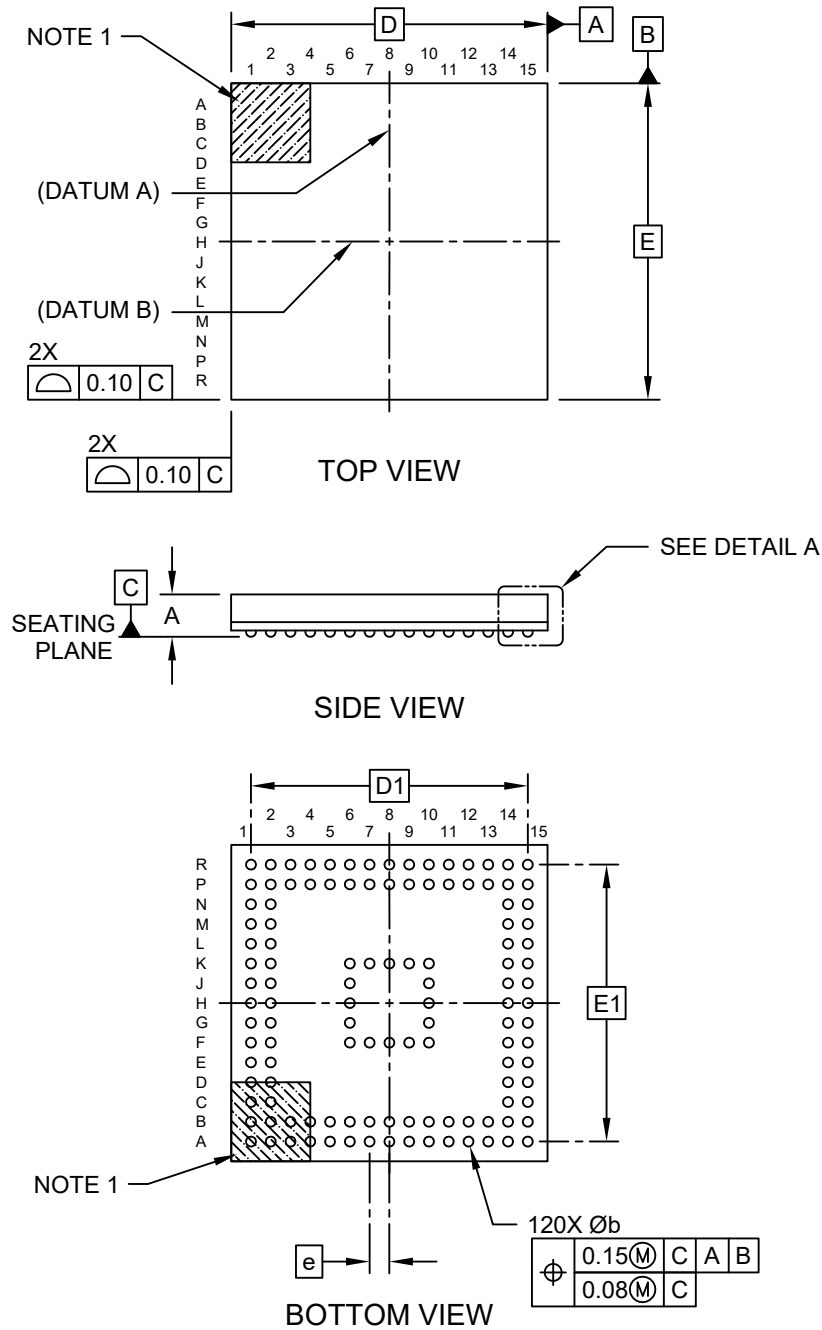
# SAM D5x/E5x Family Data Sheet

## Packaging Information

### 58.3.8 120-ball TFBGA

#### 120-Ball Thin Fine Pitch Ball Grid Array Package (DGB) - 8x8 mm Body [TFBGA]

**Note:** For the most current package drawings, please see the Microchip Packaging Specification located at <http://www.microchip.com/packaging>



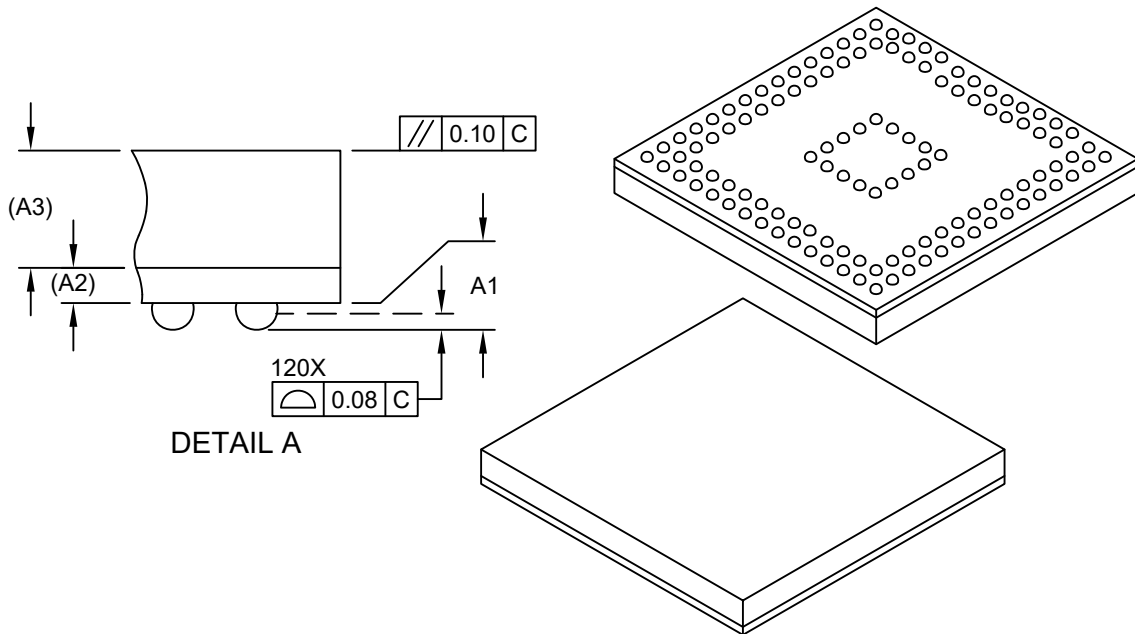
Microchip Technology Drawing C04-21465 Rev A Sheet 1 of 2

# SAM D5x/E5x Family Data Sheet

## Packaging Information

### 120-Ball Thin Fine Pitch Ball Grid Array Package (DGB) - 8x8 mm Body [TFBGA]

**Note:** For the most current package drawings, please see the Microchip Packaging Specification located at <http://www.microchip.com/packaging>



Dimension Limits	Units	MILLIMETERS		
		MIN	NOM	MAX
Number of Terminals	N	120		
Pitch	e	0.50 BSC		
Overall Height	A	-	-	1.20
Standoff	A1	0.11	-	0.21
Substrate Thickness	A2	2.10 REF		
Mold Cap Thickness	A3	0.70 REF		
Overall Length	D	8.00 BSC		
Overall Ball Pitch	D1	7.00 BSC		
Overall Width	E	8.00 BSC		
Exposed Pad Width	E1	7.00 BSC		
Terminal Width	b	0.20	-	0.30

**Notes:**

1. Pin 1 visual index feature may vary, but must be located within the hatched area.
2. Package is saw singulated
3. Dimensioning and tolerancing per ASME Y14.5M
  - BSC: Basic Dimension. Theoretically exact value shown without tolerances.
  - REF: Reference Dimension, usually without tolerance, for information purposes only.

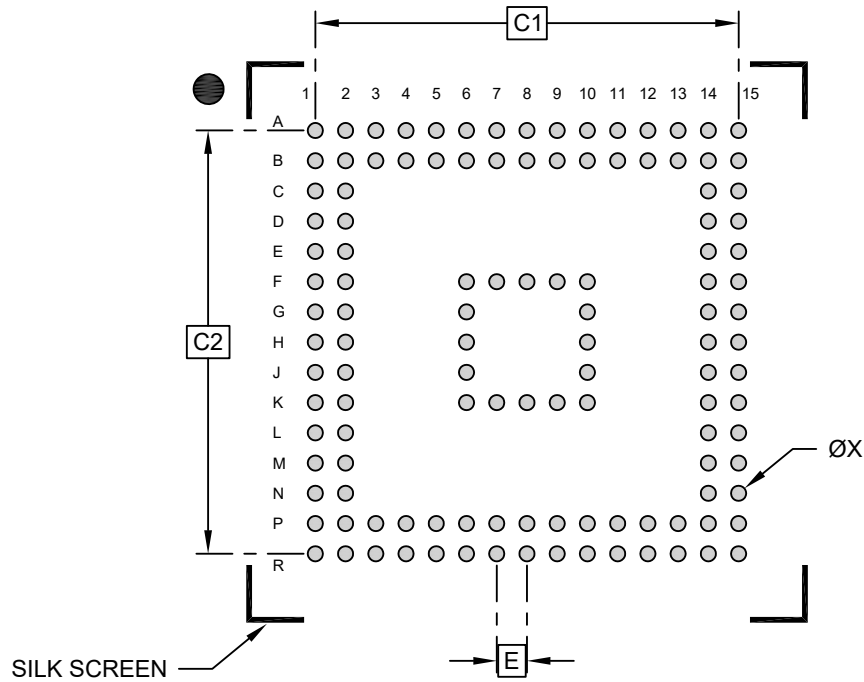
Microchip Technology Drawing C04-21465 Rev A Sheet 1 of 2

# SAM D5x/E5x Family Data Sheet

## Packaging Information

### 120-Ball Thin Fine Pitch Ball Grid Array Package (DGB) - 8x8 mm Body [TFBGA]

**Note:** For the most current package drawings, please see the Microchip Packaging Specification located at <http://www.microchip.com/packaging>



RECOMMENDED LAND PATTERN

	Units	MILLIMETERS		
		MIN	NOM	MAX
Contact Pitch	E	0.50 BSC		
Contact Pad Spacing	C1	7.00 BSC		
Contact Pad Spacing	C2	7.00 BSC		
Contact Pad Width (X20)	X		0.25	

**Notes:**

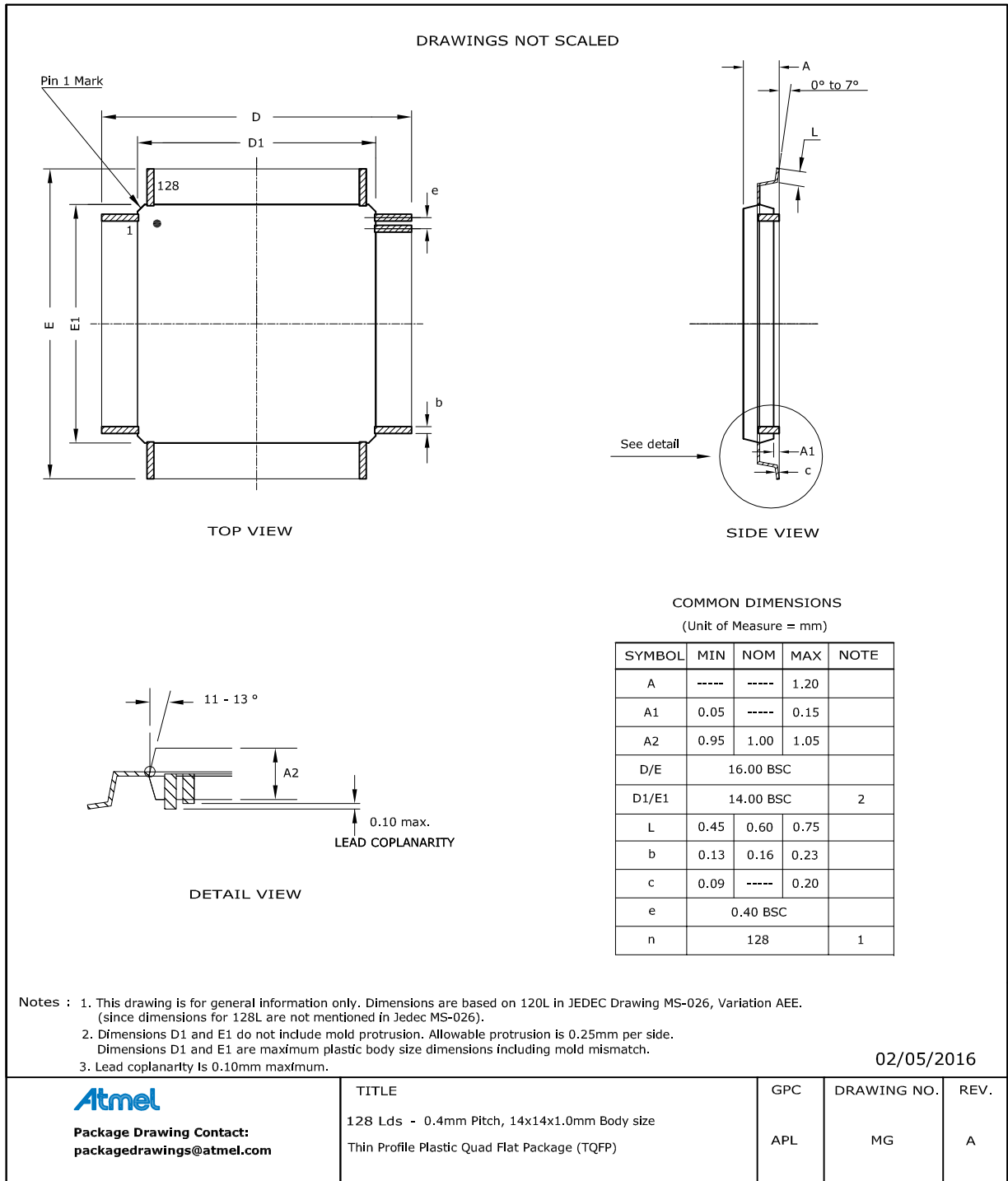
1. Dimensioning and tolerancing per ASME Y14.5M  
 BSC: Basic Dimension. Theoretically exact value shown without tolerances.

Microchip Technology Drawing C04-23465 Rev A

# SAM D5x/E5x Family Data Sheet

## Packaging Information

### 58.3.9 128 pin TQFP



**Table 58-14. Device and Package Maximum Weight**

520	mg
-----	----

**Table 58-15. Package Characteristics**

Moisture Sensitivity Level	MSL3
----------------------------	------

**Table 58-16. Package Reference**

JEDEC Drawing Reference	MS-026
JESD97 Classification	E3

### 58.4 Soldering Profile

The following table gives the recommended soldering profile from J-STD-20.

**Table 58-17. Recommended Soldering Profile**

Profile Feature	Green Package
Average Ramp-up Rate (217°C to peak)	3°C/s max.
Preheat Temperature 175°C ±25°C	150-200°C
Time Maintained Above 217°C	60-150s
Time within 5°C of Actual Peak Temperature	30s
Peak Temperature Range	260°C
Ramp-down Rate	6°C/s max.
Time 25°C to Peak Temperature	8 minutes max.

A maximum of three reflow passes is allowed per component.

## 59. Schematic Checklist

### 59.1 Introduction

This chapter describes a common checklist which should be used when starting and reviewing the schematics for a SAM D5x/E5x design. This chapter illustrates recommended power supply connections, how to connect external analog references, programmer, debugger, oscillator and crystal.

#### 59.1.1 Operation in Noisy Environment

If the device is operating in an environment with much electromagnetic noise, it must be protected from this noise to ensure reliable operation. In addition to following best practice EMC design guidelines, the recommendations listed in the schematic checklist sections must be followed. In particular, placing decoupling capacitors very close to the power pins, an RC-filter on the  $\overline{\text{RESET}}$  pin, and a pull-up resistor on the SWCLK pin is critical for reliable operations. It is also relevant to eliminate or attenuate noise in order to avoid that it reaches supply pins, I/O pins and crystals.

### 59.2 Power Supply

The SAM D5x/E5x supports a single or dual power supply from 1.71V to 3.63V. The same voltage must be applied to both VDDIO and VDDANA. VDDIOB level must be lower or equal to VDDIO / VDDANA.

When I/O pads in the VDDIOB cluster are multiplexed as analog pads, VDDANA is used to power the I/O. Using this configuration may result in an electrical conflict if the VDDIOB voltage is different from that of VDDIO / VDDANA. If the application has such requirements, it is required to power VDDIOB, VDDIO, and VDDANA from the same supply source to ensure that they are always at the same voltage.

The internal voltage regulator has four different modes:

- Linear mode: This mode does not require any external inductor. This is the default mode when CPU and peripherals are running
- Switching mode (Buck): The most efficient mode when the CPU and peripherals are running.
- Low Power (LP) mode: This is the default mode used when the device is in Standby mode
- Shutdown mode: When the device is in Backup mode, the internal regulator is turned off

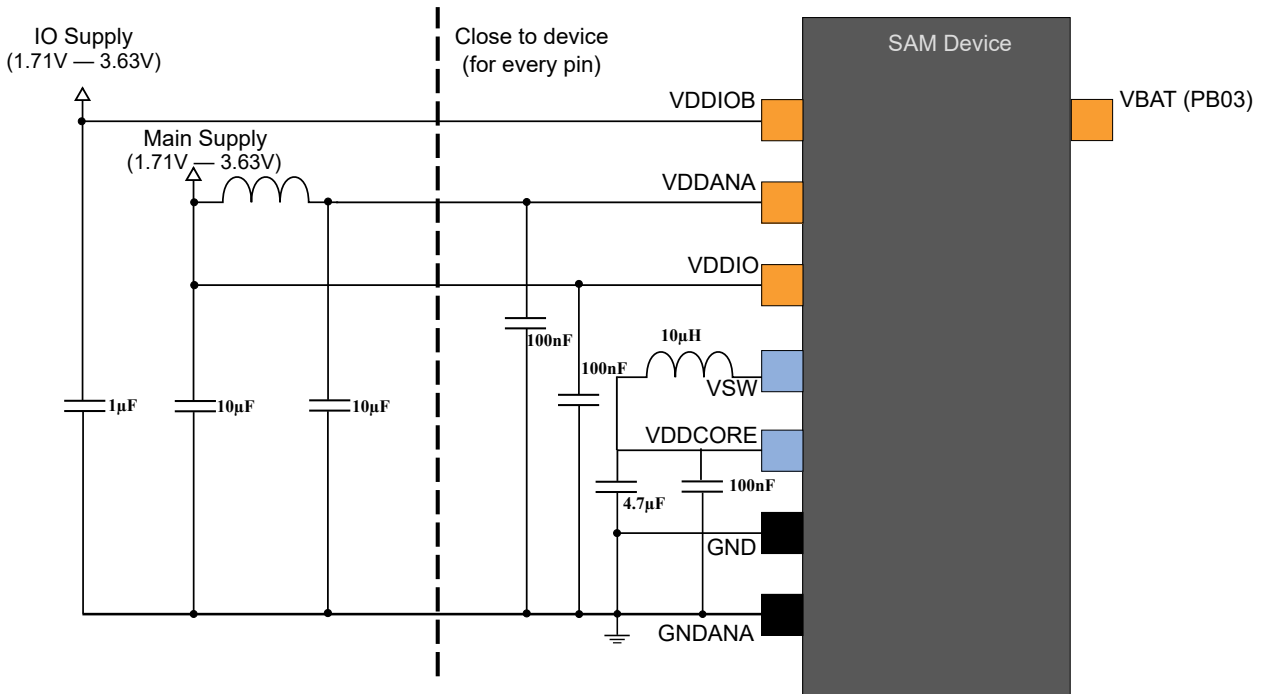
Selecting between switching mode and linear mode can be done by software on the fly, but the power supply must be designed according to which mode is to be used.

#### 59.2.1 Power Supply Connections

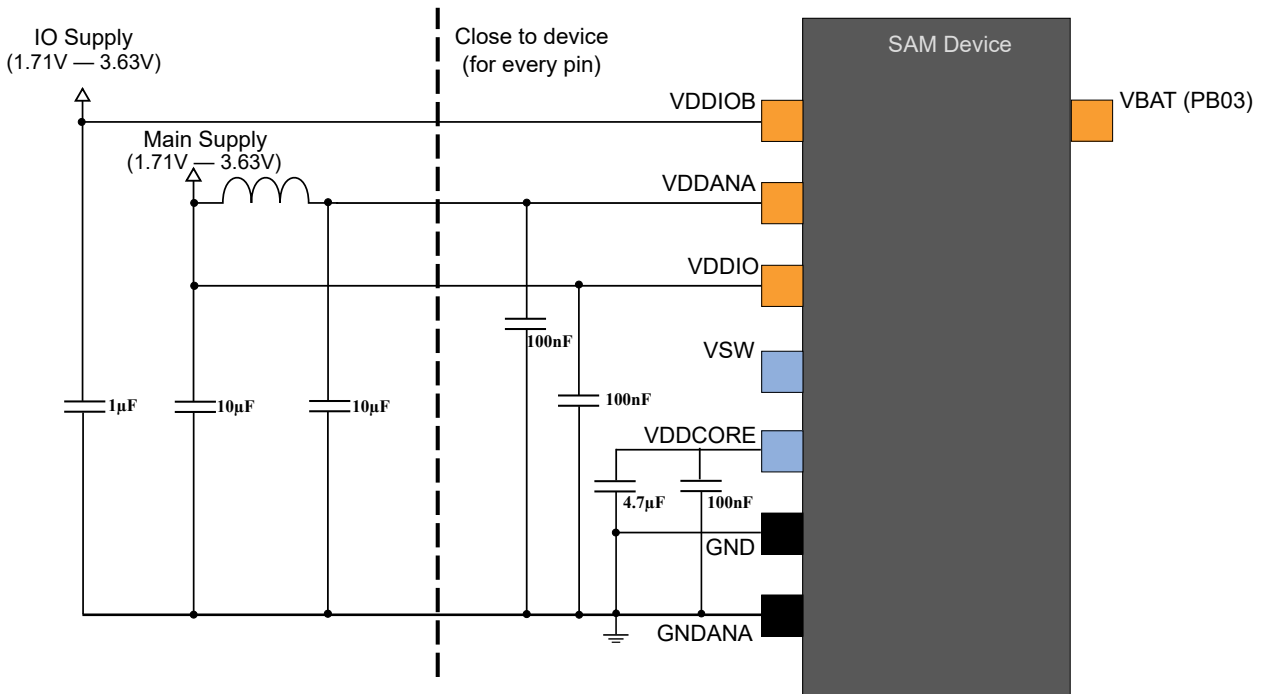
The following figures shows the recommended power supply connections for switched/linear mode, linear mode only and with battery backup.



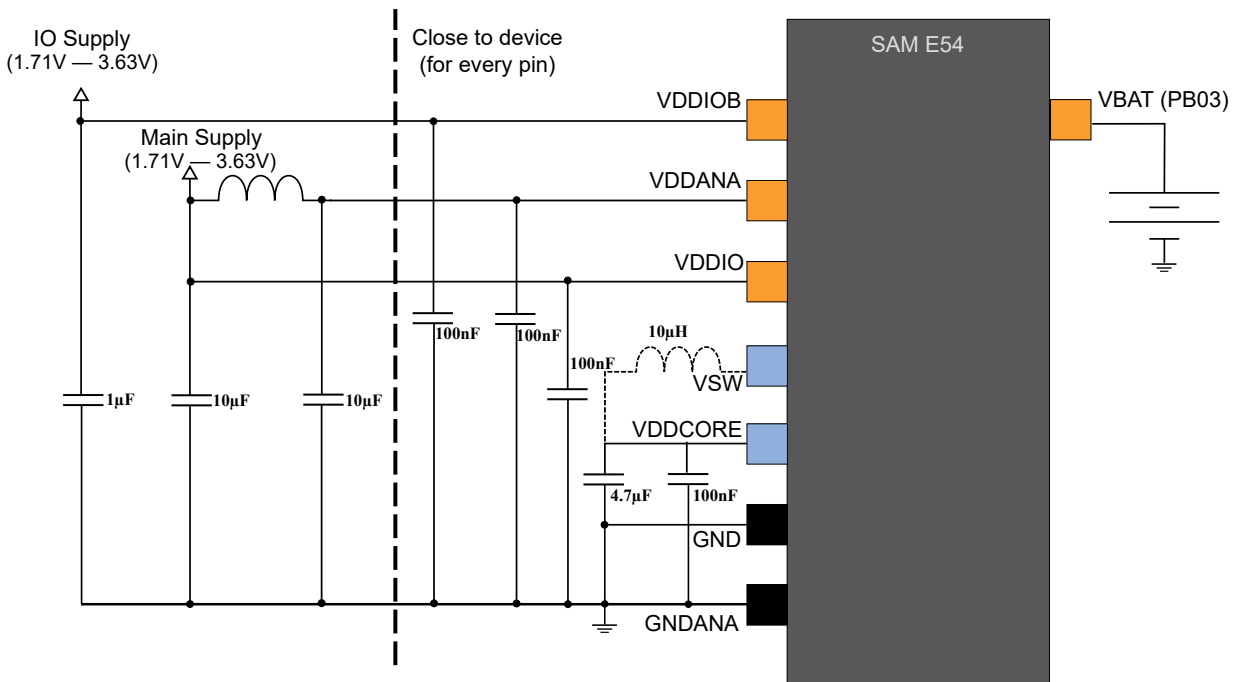
**Figure 59-1. Power Supply Connection for Switching/Linear Mode**



**Figure 59-2. Power Supply Connection for Linear Mode Only**



**Figure 59-3. Power Supply Connection for Battery Backup**



**Note:**

1. The passive component value shown in figures 58-1, 58-2 & 58-3 is a typical example. Refer to [54.10.1 Voltage Regulator Characteristics](#) for details on specification.
2. Decoupling capacitors should be placed close to the device for each supply pin pair in the signal group, low ESR capacitors should be used for better decoupling.
3. An inductor should be added between the external power and the  $V_{DD}$  for power filtering.
4. A ferrite bead has better filtering performance compared to standard inductor at high frequencies. A ferrite bead can be added between the main power supply ( $V_{DD}$ ) and  $V_{DDANA}$  to prevent digital noise from entering the analog power domain. The bead should provide enough impedance (i.e.,  $50\Omega$  at 20 MHz and  $220\Omega$  at 100 MHz) to separate the digital and analog power domains. Make sure to select a ferrite bead designed for filtering applications with a low DC resistance to avoid a large voltage drop across the ferrite bead.

### 59.3 External Analog Reference Connections

The following schematic checklist is only necessary if the application is using one or more of the external analog references. If the internal references are used instead, the following circuits are not necessary.

Figure 59-4. External Analog Reference Schematic With Three References

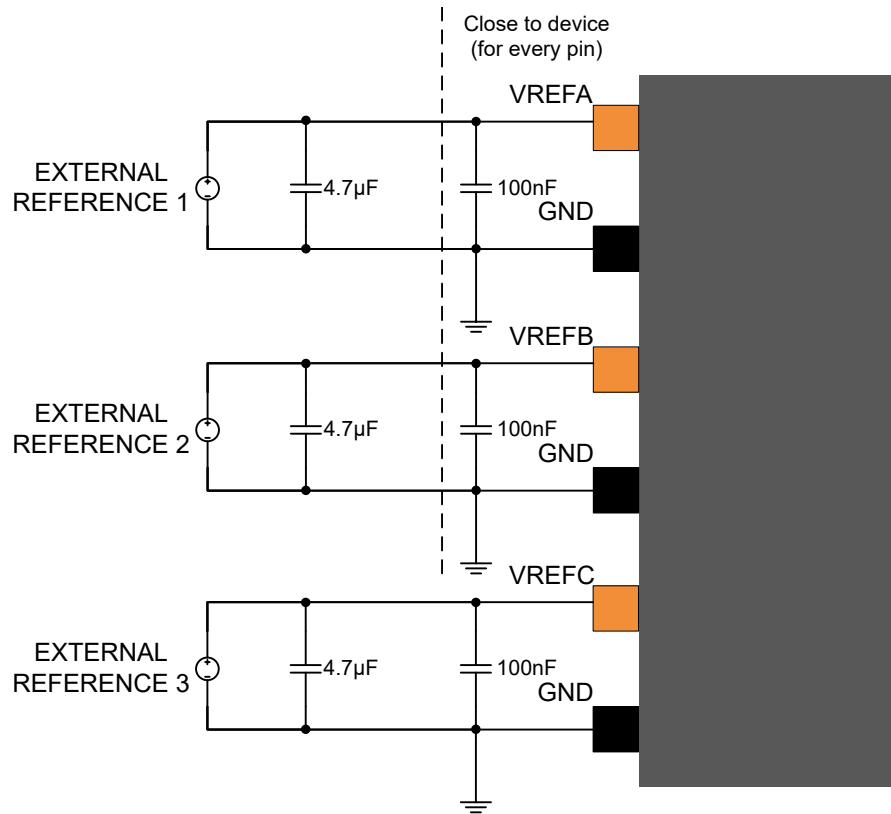
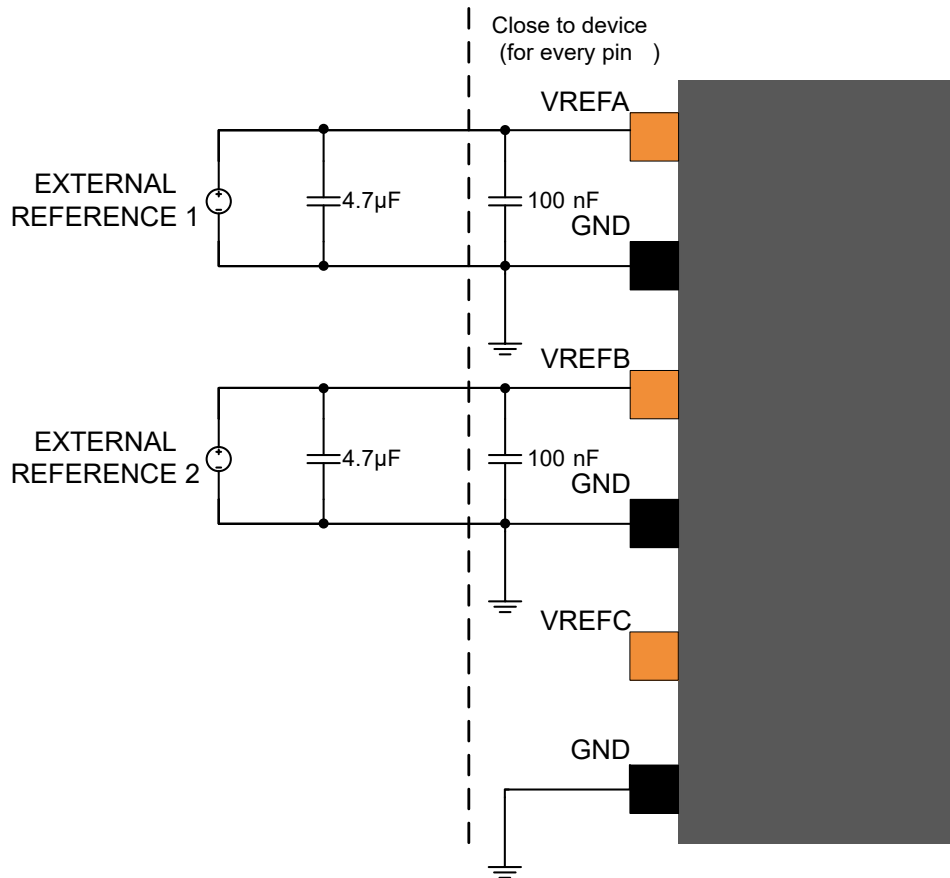
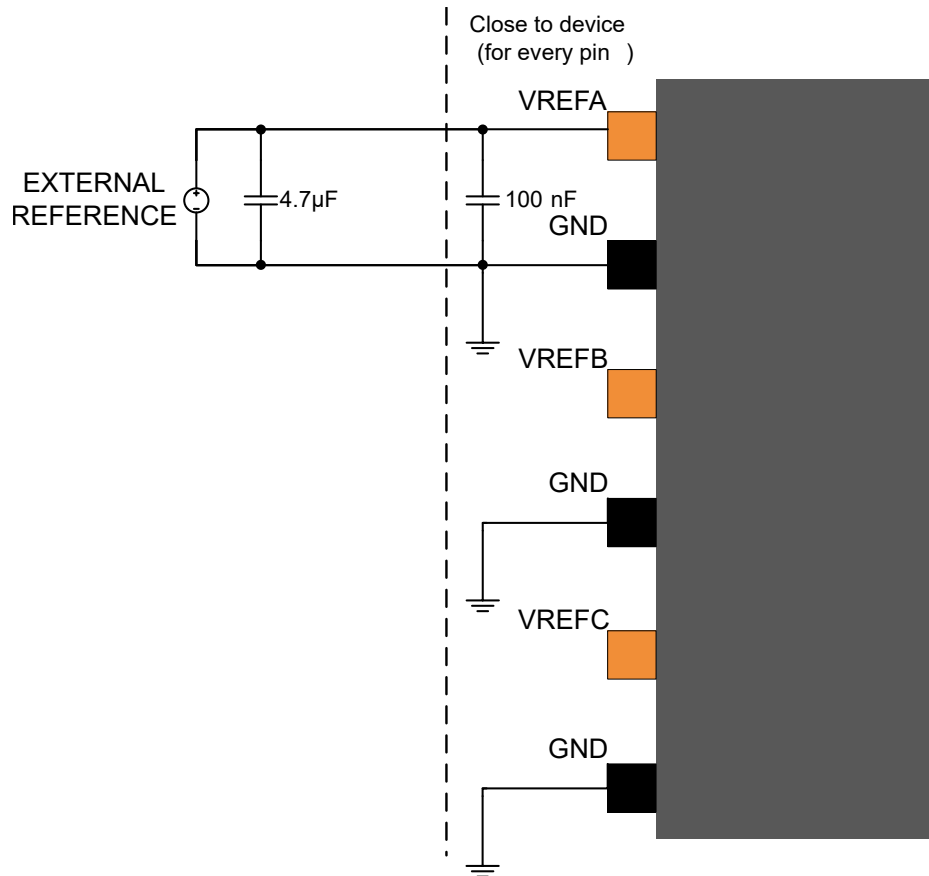


Figure 59-5. External Analog Reference Schematic With Two References



**Figure 59-6. External Analog Reference Schematic With One Reference**



**Table 59-1. External Analog Reference Connections**

Signal Name	Recommended Pin Connection	Description
VREFx	1.0V to ( $V_{DDANA} - 0.6V$ ) for ADC 1.0V to ( $V_{DDANA} - 0.6V$ ) for DAC Decoupling/filtering capacitors 100nF <sup>(1)(2)</sup> and 4.7µF <sup>(1)</sup>	External reference VREFx for the analog port
GND		Ground

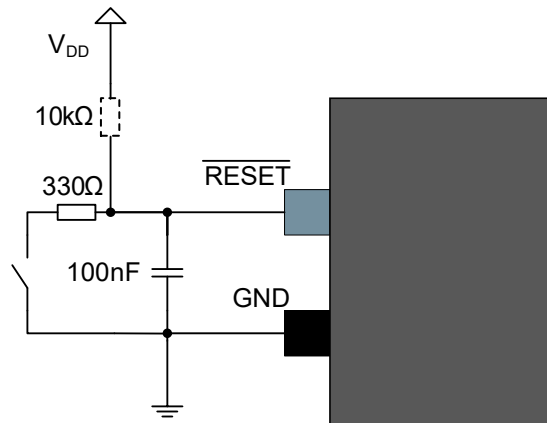
1. These values are only given as a typical example.
2. Decoupling capacitor should be placed close to the device for each supply pin pair in the signal group.

### 59.4 External Reset Circuit

When the external Reset function is used, connect the external Reset circuit to the  $\overline{\text{RESET}}$  pin as shown below. If the external Reset function is not required, the circuit is not necessary: the  $\overline{\text{RESET}}$  pin can either remain unconnected, or be driven LOW externally by the application circuitry.

The Reset switch can also be removed if a manual Reset is not necessary. The  $\overline{\text{RESET}}$  pin itself has an internal pull-up resistor, hence it is optional to add any external pull-up resistor.

**Figure 59-7. External Reset Circuit Schematic**



A pull-up resistor makes sure that the Reset does not go low and unintentionally causing a device Reset. An additional resistor has been added in series with the switch to safely discharge the filtering capacitor, i.e. preventing a current surge when shorting the filtering capacitor which again can cause a noise spike that can have a negative effect on the system.

**Table 59-2. Reset Circuit Connections**

Signal Name	Recommended Pin Connection	Description
RESET	Reset low level threshold voltage $V_{DDIO} = 1.71V - 2.0V$ : Below $0.33 * V_{DDIO}$ $V_{DDIO} = 2.7V - 3.6V$ : Below $0.36 * V_{DDIO}$ Decoupling/filter capacitor 100nF <sup>(1)</sup> Pull-up resistor 10kΩ <sup>(1,2)</sup> Resistor in series with the switch 330Ω <sup>(1)</sup>	Reset pin

1. These values are only given as a typical example.

2. The SAM D5x/E5x features an internal pull-up resistor on the  $\overline{RESET}$  pin, hence an external pull-up is optional.

### 59.5 Unused or Unconnected Pins

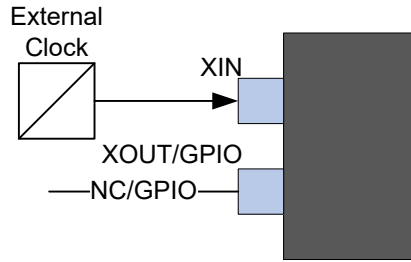
For unused pins the default state of the pins will give the lowest current leakage. Thus there is no need to do any configuration of the unused pins in order to lower the power consumption.

### 59.6 Clocks and Crystal Oscillators

The SAM D5x/E5x can be run from internal or external clock sources, or a mix of internal and external sources. An example of usage can be to use the internal 48MHz DFLL as source for the system clock and an external 32.768kHz watch crystal as clock source for the Real-Time counter (RTC).

### 59.6.1 External Clock Source

**Figure 59-8. External Clock Source Schematic**

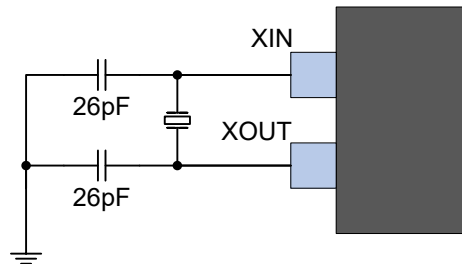


**Table 59-3. External Clock Source Connections**

Signal Name	Recommended Pin Connection	Description
XIN	XIN is used as input for an external clock signal	Input for inverting oscillator pin
XOUT/GPIO	Can be left unconnected or used as normal GPIO	NC/GPIO

### 59.6.2 Crystal Oscillator

**Figure 59-9. Crystal Oscillator Schematic**



The crystal should be located as close to the device as possible. Long signal lines may cause too high load to operate the crystal, and cause crosstalk to other parts of the system.

**Table 59-4. Crystal Oscillator Checklist**

Signal Name	Recommended Pin Connection	Description
XIN	Load capacitor 26pF <sup>(1)(2)</sup>	External crystal between 8 to 48MHz
XOUT	Load capacitor 26pF <sup>(1)(2)</sup>	

1. These values are only given as a typical example.
2. The capacitors should be placed close to the device for each supply pin pair in the signal group.

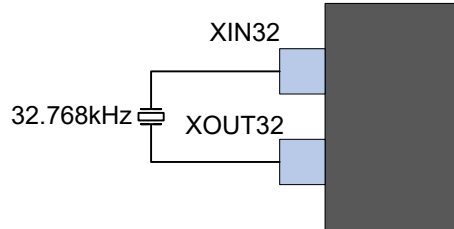
### 59.6.3 External Real Time Oscillator

The low frequency crystal oscillator is optimized for use with a 32.768kHz watch crystal. When selecting crystals, load capacitance and the crystal's Equivalent Series Resistance (ESR) must be taken into consideration. Both values are specified by the crystal vendor.

SAM D5x/E5x oscillator is optimized for very low power consumption, hence close attention should be made when selecting crystals.

The typical parasitic load capacitance values are available in the Electrical Characteristics section. This capacitance and PCB capacitance can allow using a crystal inferior to 12.5pF load capacitance without external capacitors as shown in the next figure.

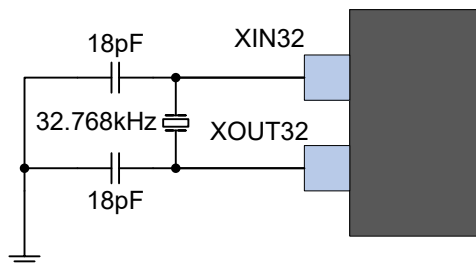
**Figure 59-10. External Real Time Oscillator without Load Capacitor**



To improve accuracy and Safety Factor, the crystal datasheet can recommend adding external capacitors as shown the figure below.

To find suitable load capacitance for a 32.768kHz crystal, consult the crystal datasheet.

**Figure 59-11. External Real Time Oscillator with Load Capacitor**



**Table 59-5. External Real Time Oscillator Checklist**

Signal Name	Recommended Pin Connection	Description
XIN32	Load capacitor 18pF <sup>(1)(2)</sup>	Timer oscillator input
XOUT32	Load capacitor 18pF <sup>(1)(2)</sup>	Timer oscillator output

1. These values are only given as typical examples.
2. The capacitors should be placed close to the device for each supply pin pair in the signal group.

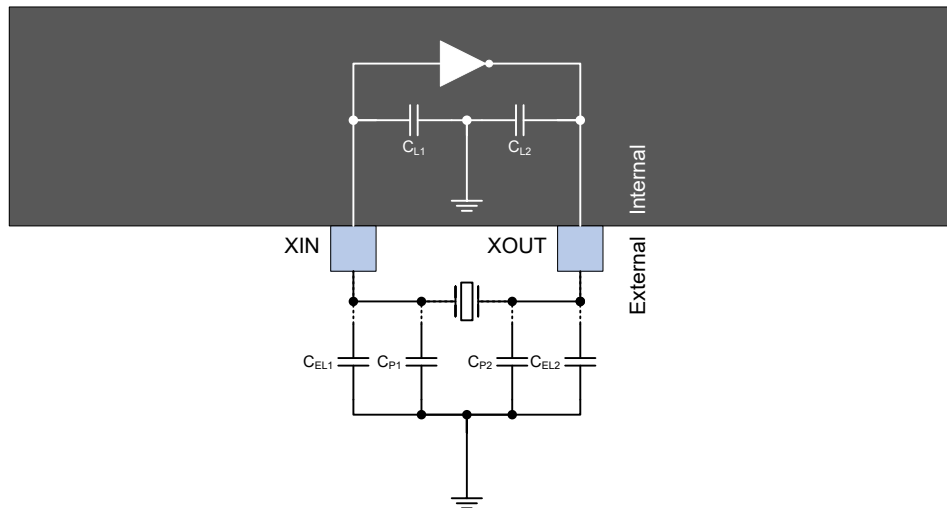
**Note:** In order to minimize the cycle-to-cycle jitter of the external oscillator, keep the neighboring pins as steady as possible. For neighboring pin details, refer to the Oscillator Pinout section.

### 59.6.4 Calculating the Correct Crystal Decoupling Capacitor

The model shown in [Figure 59-12](#) can be used to calculate correct load capacitor for a given crystal. This model includes internal capacitors  $C_{Ln}$ , external parasitic capacitance  $C_{ELn}$  and external load capacitance  $C_{Pn}$ .



**Figure 59-12. Crystal Circuit With Internal, External and Parasitic Capacitance**



Using this model the total capacitive load for the crystal can be calculated as shown in the equation below:

$$\sum C_{\text{tot}} = \frac{(C_{L1} + C_{P1} + C_{EL1})(C_{L2} + C_{P2} + C_{EL2})}{C_{L1} + C_{P1} + C_{EL1} + C_{L2} + C_{P2} + C_{EL2}}$$

where  $C_{\text{tot}}$  is the total load capacitance seen by the crystal. This value should be equal to the load capacitance value found in the crystal manufacturer datasheet.

The parasitic capacitance  $C_{ELn}$  can in most applications be disregarded as these are usually very small. If accounted for, these values are dependent on the PCB material and PCB layout.

For some crystal the internal capacitive load provided by the device itself can be enough. To calculate the total load capacitance in this case,  $C_{ELn}$  and  $C_{Pn}$  are both zero,  $C_{L1} = C_{L2} = C_L$ , and the equation reduces to the following:

$$\sum C_{\text{tot}} = \frac{C_L}{2}$$

See the related links for equivalent internal pin capacitance values.

## 59.7 Programming and Debug Ports

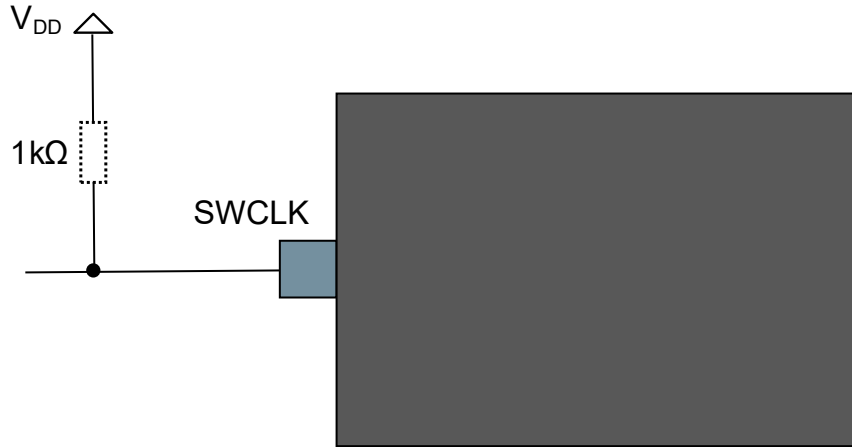
For programming and/or debugging the SAM D5x/E5x, the device should be connected using the Serial Wire Debug, SWD, interface. Currently the SWD interface is supported by several Microchip and third party programmers and debuggers, like the Atmel-ICE, SAM-ICE or SAM D5x/E5x Xplained Pro (SAM D5x/E5x evaluation kit) Embedded Debugger.

Refer to the Atmel-ICE, SAM-ICE or SAM D5x/E5x Xplained Pro user guides for details on debugging and programming connections and options. For connecting to any other programming or debugging tool, refer to that specific programmer or debugger's user guide.

The SAM D5x/E5x Xplained Pro evaluation board supports programming and debugging through the onboard embedded debugger so no external programmer or debugger is needed.

**Note:** A pull-up resistor on the SWCLK pin is critical for reliable operation. Refer to related link for more information.

**Figure 59-13. SWCLK Circuit Connections**



**Table 59-6. SWCLK Circuit Connections**

Pin Name	Description	Recommended Pin Connection
SWCLK	Serial wire clock pin	Pull-up resistor 1kΩ

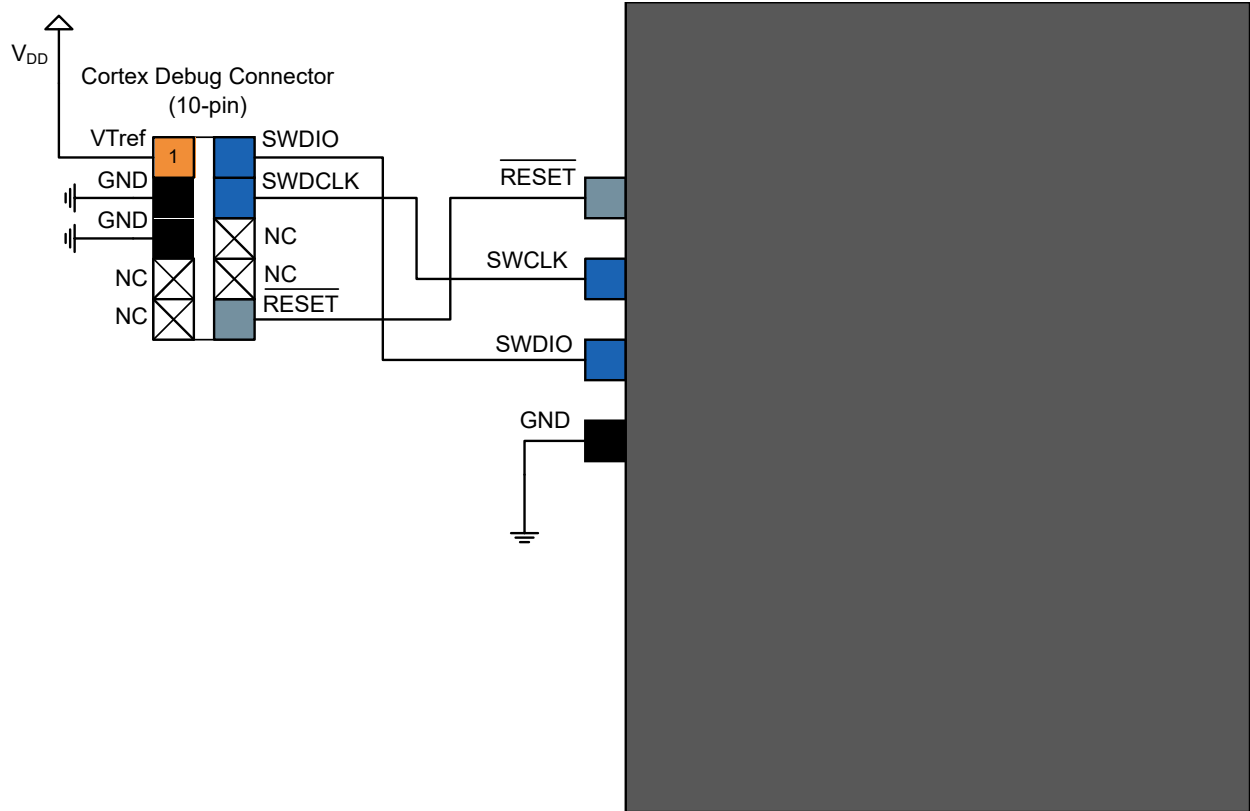
**Related Links**

[59.1.1 Operation in Noisy Environment](#)

**59.7.1 Cortex Debug Connector (10-pin)**

For debuggers and/or programmers that support the Cortex Debug Connector (10-pin) interface the signals should be connected as shown in [Figure 59-14](#) with details described in [Table 59-7](#).

**Figure 59-14. Cortex Debug Connector (10-pin)**



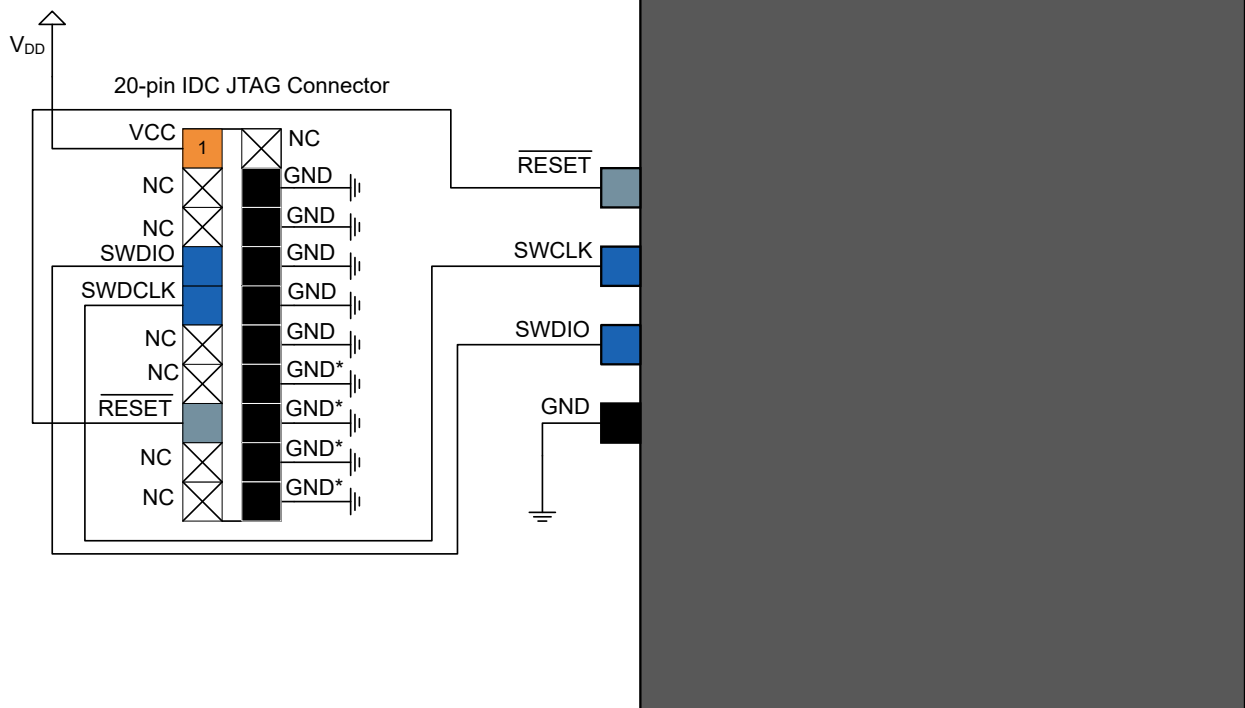
**Table 59-7. Cortex Debug Connector (10-pin)**

Header Signal Name	Description
SWDCLK	Serial wire clock pin
SWDIO	Serial wire bidirectional data pin
RESET	Target device reset pin, active low
VTref	Target voltage sense, should be connected to the device $V_{DD}$
GND	Ground

### 59.7.2 20-pin IDC JTAG Connector

For debuggers and/or programmers that support the 20-pin IDC JTAG Connector, e.g. the SAM-ICE, the signals should be connected as shown in [Figure 59-15](#) with details described in [Table 59-8](#).

**Figure 59-15. 20-pin IDC JTAG Connector**



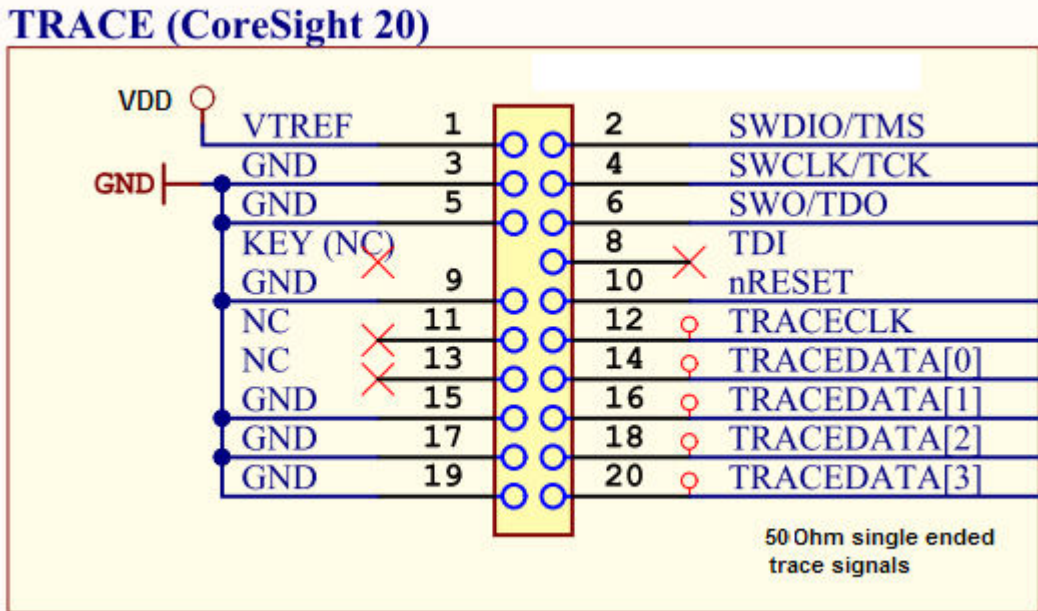
**Table 59-8. 20-pin IDC JTAG Connector**

Header Signal Name	Description
SWDCLK	Serial wire clock pin
SWDIO	Serial wire bidirectional data pin
RESET	Target device reset pin, active low
VCC	Target voltage sense, should be connected to the device $V_{DD}$
GND	Ground
GND*	These pins are reserved for firmware extension purposes. They can be left unconnected or connected to GND in normal debug environment. They are not essential for SWD in general.

### 59.7.3 Trace (CoreSight 20) Connector

The Trace Port Interface Unit (TPIU) takes data from the Embedded Trace Module (ETM) and allows debugger communication to ETM. The following figure shows the connection diagram.

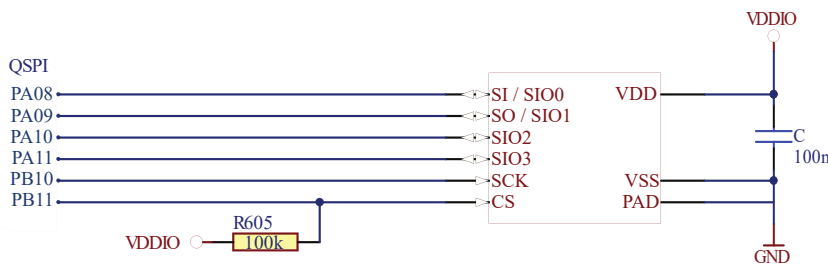
Figure 59-16. Trace (CoreSight 20) Connector Diagram



## 59.8 QSPI Interface

Table 59-9. QSPI Interface Pins and Connections

Pin Name	Recommended Pin Connection	Description
PA08 - PA11	Application dependent	QSPI I/O lines
PB10	Application dependent	QSPI Clock
PB11	Application dependent	QSPI Chip Select



**Note:** Signal integrity can be improved by adding series resistors on each QSPI line. The resistor value should be based on the corresponding I/O pin drive strength (decided by PINCFGn.DRVSTR) and PCB trace impedance. It is recommended to do simulation using the device IBIS files to choose the correct termination and PCB trace impedance combination.

## 59.9 USB Interface

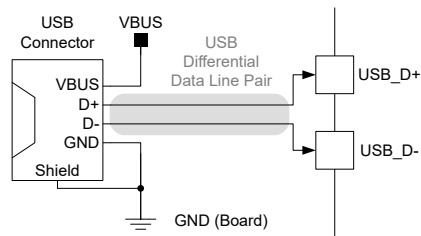
The USB interface consists of a differential data pair (D+/D-) and a power supply (VBUS, GND).

Refer to the Electrical Characteristics section for operating voltages which will allow USB operation.

**Table 59-10. USB Interface Checklist**

Signal Name	Recommended Pin Connection	Description
D+	<ul style="list-style-type: none"> <li>The impedance of the pair should be matched on the PCB to minimize reflections.</li> <li>USB differential tracks should be routed with the same characteristics (length, width, number of vias, etc.)</li> <li>For a tightly coupled differential pair, the signal routing should be as parallel as possible, with a minimum number of angles and vias.</li> </ul>	USB full speed / low speed positive data upstream pin
D-		USB full speed / low speed negative data upstream pin

**Figure 59-17. Low Cost USB Interface Example Schematic**

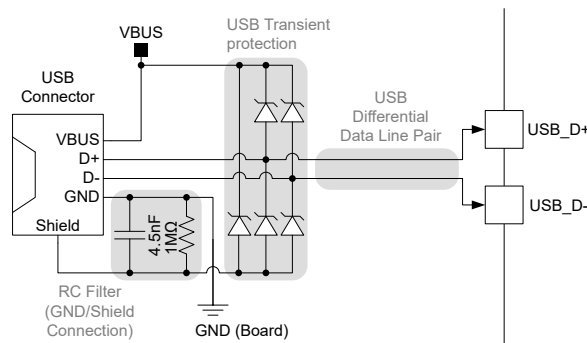


It is recommended to increase ESD protection on the USB D+, D-, and VBUS lines using dedicated transient suppressors. These protections should be located as close as possible to the USB connector to reduce the potential discharge path and reduce discharge propagation within the entire system.

The USB FS cable includes a dedicated shield wire that should be connected to the board with caution. Special attention should be paid to the connection between the board ground plane and the shield from the USB connector and the cable.

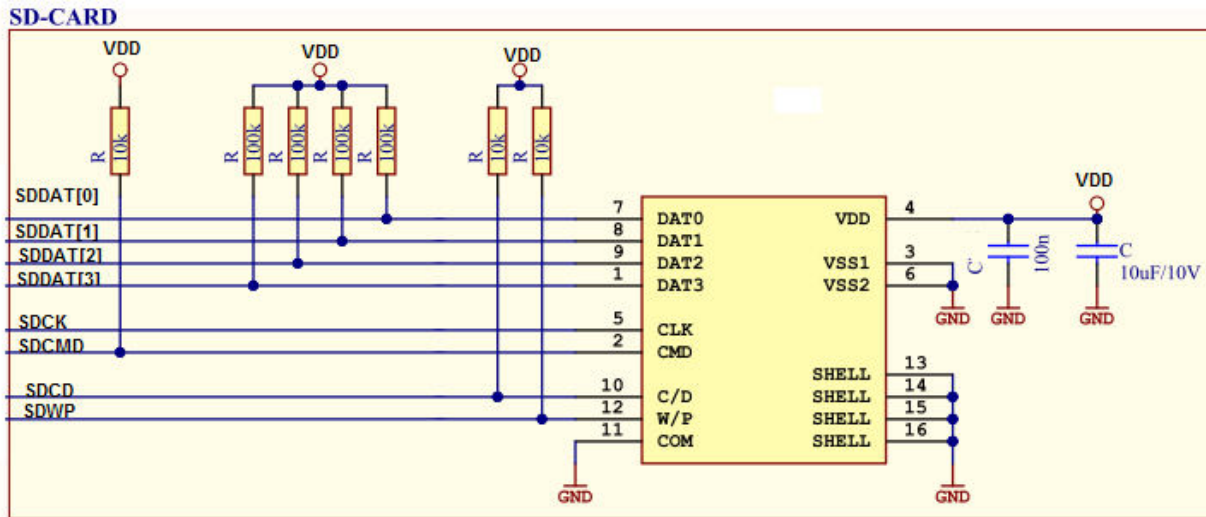
Tying the shield directly to ground would create a direct path from the ground plane to the shield, turning the USB cable into an antenna. To limit the USB cable antenna effect, it is recommended to connect the shield and ground through an RC filter.

**Figure 59-18. Protected USB Interface Example Schematic**



### 59.10 SDHC Interface

The SD/MMC Host Controller (SDHC) is compliant with the SD Host Controller Standard specifications. There are two instances of SDHC available on this device: SDHC0 and SDHC1. The typical connection diagram is shown in the following figure.



## 60. Conventions

### 60.1 Numerical Notation

**Table 60-1. Numerical Notation**

Symbol	Description
165	Decimal number
0b0101	Binary number (example 0b0101 = 5 decimal)
'0101'	Binary numbers are given without prefix if unambiguous
0x3B24	Hexadecimal number
X	Represents an unknown or do not care value
Z	Represents a high-impedance (floating) state for either a signal or a bus

### 60.2 Memory Size and Type

**Table 60-2. Memory Size and Bit Rate**

Symbol	Description
KB (kbyte)	kilobyte ( $2^{10} = 1024$ )
MB (Mbyte)	megabyte ( $2^{20} = 1024*1024$ )
GB (Gbyte)	gigabyte ( $2^{30} = 1024*1024*1024$ )
b	bit (binary '0' or '1')
B	byte (8 bits)
1kbit/s	1,000 bit/s rate (not 1,024 bit/s)
1Mbit/s	1,000,000 bit/s rate
1Gbit/s	1,000,000,000 bit/s rate
word	32 bit
half-word	16 bit

### 60.3 Frequency and Time

**Table 60-3. Frequency and Time**

Symbol	Description
kHz	1 kHz = $10^3$ Hz = 1,000 Hz



.....continued	
Symbol	Description
KHz	1 KHz = 1,024 Hz, 32 KHz = 32,768 Hz
MHz	1 MHz = 10 <sup>6</sup> Hz = 1,000,000 Hz
GHz	1 GHz = 10 <sup>9</sup> Hz = 1,000,000,000 Hz
s	second
ms	millisecond
μs	microsecond
ns	nanosecond

## 60.4 Registers and Bits

**Table 60-4. Register and Bit Mnemonics**

Symbol	Description
R/W	Read/Write accessible register bit. The user can read from and write to this bit.
R	Read-only accessible register bit. The user can only read this bit. Writes will be ignored.
W	Write-only accessible register bit. The user can only write this bit. Reading this bit will return an undefined value.
BIT	Bit names are shown in uppercase. (Example ENABLE)
FIELD[n:m]	A set of bits from bit n down to m. (Example: PINA[3:0] = {PINA3, PINA2, PINA1, PINA0})
Reserved	Reserved bits are unused and reserved for future use. For compatibility with future devices, always write reserved bits to zero when the register is written. Reserved bits will always return zero when read.  Reserved bit field values must not be written to a bit field. A reserved value will not be read from a read-only bit field.  Do not write any value to reserved bits of a fuse.
PERIPHERAL <i>i</i>	If several instances of a peripheral exist, the peripheral name is followed by a number to indicate the number of the instance in the range 0-n. PERIPHERAL0 denotes one specific instance.
Reset	Value of a register after a Power-on Reset. This is also the value of registers in a peripheral after performing a software Reset of the peripheral, except for the Debug Control registers.

# SAM D5x/E5x Family Data Sheet

## Conventions

.....continued

Symbol	Description
SET/CLR	Registers with SET/CLR suffix allows the user to clear and set bits in a register without doing a read-modify-write operation. These registers always come in pairs. Writing a '1' to a bit in the CLR register will clear the corresponding bit in both registers, while writing a '1' to a bit in the SET register will set the corresponding bit in both registers. Both registers will return the same value when read. If both registers are written simultaneously, the write to the CLR register will take precedence.

### 61. Acronyms and Abbreviations

The below table contains acronyms and abbreviations used in this document.

**Table 61-1. Acronyms and Abbreviations**

Abbreviation	Description
AC	Analog Comparator
ADC	Analog-to-Digital Converter
ADDR	Address
AES	Advanced Encryption Standard
AHB	Advanced High-performance Bus
AMBA	Advanced Microcontroller Bus Architecture
APB	AMBA Advanced Peripheral Bus
AREF	Analog Reference Voltage
BOD	Brown-out Detector
CAL	Calibration
CC	Compare/Capture
CCL	Configurable Custom Logic
CLK	Clock
CRC	Cyclic Redundancy Check
CTRL	Control
DAC	Digital-to-Analog Converter
DAP	Debug Access Port
DFLL	Digital Frequency Locked Loop
DPLL	Digital Phase Locked Loop
DMAC	DMA (Direct Memory Access) Controller
DSU	Device Service Unit
EEPROM	Electrically Erasable Programmable Read-Only Memory
EIC	External Interrupt Controller
EVSYS	Event System
FDPLL	Fractional Digital Phase Locked Loop, also DPLL
FREQM	Frequency Meter
GCLK	Generic Clock Controller
GMII	Gigabit Media Independent Interface

# SAM D5x/E5x Family Data Sheet

## Acronyms and Abbreviations

.....continued	
Abbreviation	Description
GND	Ground
GPIO	General Purpose Input/Output
I <sup>2</sup> C	Inter-Integrated Circuit
IF	Interrupt Flag
INT	Interrupt
MBIST	Memory Built-In Self-Test
MEM-AP	Memory Access Port
MIB	Management Information Base
MII	Media Independent Interface
MTB	Micro Trace Buffer
NMI	Non-maskable Interrupt
NVIC	Nested Vector Interrupt Controller
NVM	Nonvolatile Memory
NVMCTRL	Nonvolatile Memory Controller
OSC	Oscillator
PAC	Peripheral Access Controller
PC	Program Counter
PER	Period
PM	Power Manager
POR	Power-on Reset
PORT	I/O Pin Controller
PTC	Peripheral Touch Controller
PWM	Pulse-Width Modulation
RAM	Random-Access Memory
REF	Reference
RMII	Reduced Media Independent Interface
RTC	Real-Time Counter
RX	Receiver/Receive
SEES	SmartEEPROM Sector
SEEP	SmartEEPROM Page
SERCOM	Serial Communication Interface

# SAM D5x/E5x Family Data Sheet

## Acronyms and Abbreviations

.....continued

Abbreviation	Description
SMBus	System Management Bus
SNAP	Sub-Network Access Protocol
SP	Stack Pointer
SPI	Serial Peripheral Interface
SRAM	Static Random Access Memory
SUPC	Supply Controller
SWD	Serial Wire Debug
TC	Timer/Counter
TRNG	True Random Number Generator
TX	Transmitter/Transmit
ULP	Ultra Low-Power
USART	Universal Synchronous and Asynchronous Serial Receiver and Transmitter
USB	Universal Serial Bus
V <sub>DD</sub>	Common voltage to be applied to VDDIO and VDDANA
V <sub>DDIO</sub>	Digital Supply Voltage
V <sub>DDANA</sub>	Analog Supply Voltage
VREF	Voltage Reference
WDT	Watchdog Timer
XOSC	Crystal Oscillator

## 62. Revision History

Table 62-1. Revision E - 06/2019

Section Name or Type	Change Description
Introduction	Updated sections: <ul style="list-style-type: none"> <li>• Updated <a href="#">Features</a></li> <li>• Updated the <a href="#">Configuration Summary</a></li> </ul>
<a href="#">Processor and Architecture</a>	Updated <a href="#">Interrupt Line Mapping</a>
<a href="#">CMCC</a>	Updated sections: <ul style="list-style-type: none"> <li>• <a href="#">Data Cache Disable</a></li> <li>• <a href="#">Instruction Cache Disable</a></li> </ul>
<a href="#">GCLK</a>	Updated the <a href="#">PCHCTRLm</a> register
<a href="#">PM</a>	Updated <a href="#">Backup Mode</a>
<a href="#">RTC</a>	<p>Count32 Registers updated:</p> <ul style="list-style-type: none"> <li>• <a href="#">CTRLA</a></li> <li>• <a href="#">EVCTRL</a></li> <li>• <a href="#">INTENCLR</a></li> <li>• <a href="#">INTENSET</a></li> <li>• <a href="#">INTFLAG</a></li> <li>• <a href="#">SYNCBUSY</a></li> <li>• <a href="#">GPn</a></li> </ul> <p>Count16 Registers updated:</p> <ul style="list-style-type: none"> <li>• <a href="#">CTRLA</a></li> <li>• <a href="#">EVCTRL</a></li> <li>• <a href="#">INTENCLR</a></li> <li>• <a href="#">INTENSET</a></li> <li>• <a href="#">INTFLAG</a></li> <li>• <a href="#">SYNCBUSY</a></li> <li>• <a href="#">GPn</a></li> </ul> <p>The following Clock registers were updated:</p> <ul style="list-style-type: none"> <li>• <a href="#">CTRLA</a></li> <li>• <a href="#">EVCTRL</a></li> <li>• <a href="#">INTENCLR</a></li> <li>• <a href="#">INTENSET</a></li> <li>• <a href="#">INTFLAG</a></li> <li>• <a href="#">SYNCBUSY</a></li> <li>• <a href="#">GPn</a></li> </ul>

# SAM D5x/E5x Family Data Sheet

## Revision History

.....continued	
Section Name or Type	Change Description
DMAC	<p>The following topics were updated:</p> <ul style="list-style-type: none"> <li>Initialization</li> <li>Enabling, Disabling and Resetting</li> <li>Transfer Descriptors</li> </ul> <p>The following registers were updated:</p> <ul style="list-style-type: none"> <li>CTRL</li> <li>SWTRIGCTRL</li> <li>INTSTATUS</li> <li>BUSYCH</li> </ul>
GMAC	<p>The following topics were updated:</p> <ul style="list-style-type: none"> <li>Features</li> <li>Pause Frame Reception</li> </ul>
OSCCTRL	<p>The following topics were updated:</p> <ul style="list-style-type: none"> <li>Digital Phase Locked Loop (DPLL) Operation</li> </ul>
SERCOM-SPI	<p>Updated the following topics:</p> <ul style="list-style-type: none"> <li>Clock Generation</li> </ul>
QSPI	<p>Updated the following topics:</p> <ul style="list-style-type: none"> <li>Continuous Read Mode</li> </ul>
SDMMC	<p>Updated the following registers:</p> <ul style="list-style-type: none"> <li>PSR</li> <li>PCR</li> <li>NISTR</li> <li>NISTER</li> <li>HC2R EMMC</li> <li>HC2R SDIO</li> <li>CA0R</li> <li>CA1R</li> <li>MCCAR</li> <li>ASAR</li> <li>PVRx</li> <li>MC1R</li> <li>ACR</li> </ul>
ADC	<p>Updated the <a href="#">INPUTCTRL</a> register</p>
AC	<p>Updated the following sections:</p> <ul style="list-style-type: none"> <li>Signal Description</li> </ul>

# SAM D5x/E5x Family Data Sheet

## Revision History

.....continued	
Section Name or Type	Change Description
TC	Updated the following sections: <ul style="list-style-type: none"> <li>• Counter Mode</li> </ul>
TCC	Updated the following sections: <ul style="list-style-type: none"> <li>• Capture Operations</li> </ul> Updated the following registers: <ul style="list-style-type: none"> <li>• WAVE</li> </ul>
I <sup>2</sup> S	Updated the following sections: <ul style="list-style-type: none"> <li>• DMA Operation</li> </ul> Updated the following registers: <ul style="list-style-type: none"> <li>• CTRLA</li> <li>• INTENCLR</li> <li>• INTENSET</li> <li>• INTFLAG</li> <li>• SYNCBUSY</li> <li>• TXCTRL</li> <li>• RXCTRL</li> </ul>
Electrical Characteristics at 85°C	Updated the following sections: <ul style="list-style-type: none"> <li>• General Operating Ratings</li> <li>• Injection Current</li> <li>• Power Consumption</li> <li>• Analog-to-Digital Characteristics</li> <li>• Digital-to-Analog Converter Characteristics</li> </ul> Added in new section: <ul style="list-style-type: none"> <li>• PTC Characteristics</li> </ul>
Electrical Characteristics at 105°C	Updated the following sections: <ul style="list-style-type: none"> <li>• Power Consumption</li> <li>• Digital-to-Analog Converter Characteristics</li> <li>• Analog-to-Digital Characteristics</li> </ul> Added new section: <ul style="list-style-type: none"> <li>• PTC Characteristics</li> </ul>



# SAM D5x/E5x Family Data Sheet

## Revision History

.....continued

Section Name or Type	Change Description
Electrical Characteristics at 125°C	Updated the following sections: <ul style="list-style-type: none"> <li>• <a href="#">Power Consumption</a></li> <li>• <a href="#">Analog-To-Digital Characteristics</a></li> <li>• <a href="#">Digital-to-Analog Characteristics</a></li> </ul> Added new section: <ul style="list-style-type: none"> <li>• <a href="#">PTC Characteristics</a></li> </ul>

**Table 62-2. Rev. D - 12/2018**

Section Name or Type	Change Description
Ordering Information	Added AEC-Q100 Qualified package type.
I/O Multiplexing and Considerations	Added information for GRXDV pin for 64-pin package devices.
AEC Q-100 Grade 1, 125°C Electrical Characteristics	Introduced device part numbers with AEC Q-100 Grade 1.

**Table 62-3. Rev. C - 11/2018**

Section Name or Type	Change Description
Ordering Information	Added ordering information for 105°C and 125°C temperature grade.
Pinout	Exposed pad info added for VQFN package.
I/O Multiplexing and Considerations	Corrected typographical errors for pin numbers PB19 and PB23.
Memories	Clarified NVM User Page size in <a href="#">table 9-1</a> .
Processor and Architecture	Corrected typographical errors in section <a href="#">10.2.2 Interrupt Line Mapping</a> for SERCOMx interrupt line 7.
MCLK	Corrected typographical errors related to R/W bits for <a href="#">15.8.8 APBA Mask Register</a> .
PM	Updated <a href="#">Figure 18-2</a> Operating Conditions and SleepWalking to reflect that PL0 is not applicable to this product.
SUPC	Updated <a href="#">INTENCLR</a> , <a href="#">INTENSET</a> , <a href="#">INTFLAG</a> , and <a href="#">STATUS</a> Registers to reflect factory preprogramming of BOD12.
DMAC	Removed CHIP.ID information as it is not applicable to this product.

# SAM D5x/E5x Family Data Sheet

## Revision History

.....continued	
Section Name or Type	Change Description
EVSYS	Corrected typographical errors in the <a href="#">USERm Register</a> offset.
CCL	<ol style="list-style-type: none"> <li>1. Internal Events Inputs Selection (EVENT) section was updated by removing ASYNCEVENT related information.</li> <li>2. Alternate 2 TC input source not applicable and was removed for <a href="#">LUTCTRL.INSELx</a> bits.</li> </ol>
ADC	Added clarification for INTREF to <a href="#">45.8.6 Reference Control(REFCTRL)</a> .
TC	<ol style="list-style-type: none"> <li>1. <a href="#">48.7.1 Register Summary</a> - 8-bit Mode               <ul style="list-style-type: none"> <li>– Updated register bitfield with indexing to display usage.</li> </ul> </li> <li>2. <a href="#">48.7.2 Register Summary</a> - 16-bit Mode               <ol style="list-style-type: none"> <li>2.1. Updated register bitfield with indexing to display usage.</li> <li>2.2. Removed inapplicable register PER &amp; PERBUF register information.</li> </ol> </li> <li>3. <a href="#">48.7.3 Register Summary</a> - 32-bit Mode               <ol style="list-style-type: none"> <li>3.1. Updated register bitfield with indexing to display usage.</li> <li>3.2. Removed inapplicable register PER &amp; PERBUF register information.</li> </ol> </li> </ol>
<a href="#">TCC - Timer/Counter for Control Applications</a>	<ol style="list-style-type: none"> <li>1. <a href="#">Table 49-4</a>. Output Matrix Channel Pin Routing Configuration updated to show all supported 6 capture channels.</li> <li>2. <a href="#">Table 49-8</a>. Fault and Capture Action updated by adding missing CAPTMARK value for CAPTURE bit fields.</li> <li>3. Register <a href="#">INTENCLR</a>, <a href="#">INTENSET</a>, <a href="#">INTFLAG</a> updated with missing UFS bit.</li> <li>4. Removed unsupported bit info for the register <a href="#">49.8.15 Pattern (PATT)</a>.</li> <li>5. Missing POLx bits added to the register <a href="#">49.8.16 Waveform (WAVE)</a>.</li> <li>6. <a href="#">49.7 Register Summary</a> <ul style="list-style-type: none"> <li>– Updated register bitfield with indexing to display usage.</li> </ul> </li> </ol>

# SAM D5x/E5x Family Data Sheet

## Revision History

.....continued	
Section Name or Type	Change Description
54. <a href="#">Electrical Characteristics at 85°C</a>	<ol style="list-style-type: none"> <li>1. Clarified how C<sub>LEXT</sub> can be computed in section <a href="#">54.12.1 Crystal Oscillator (XOSC) Characteristics</a> and <a href="#">54.12.2 External 32 kHz Crystal Oscillator (XOSC32K) Characteristics</a></li> <li>2. Clarified capacitor requirements in <a href="#">Table 54-18. External Components Requirements in Switching Mode</a> and <a href="#">Table 54-19 Decoupling Requirements</a>.</li> <li>3. Condition shown for VREF parameter is removed in <a href="#">table 54-24. Operating Conditions</a>.</li> <li>4. Conditions specified for <a href="#">table 54-29 Differential Mode</a> is clarified for INL &amp; DNL with Internal voltage reference.</li> <li>5. <a href="#">Table 54-35. Flash Timing Characteristics</a> is updated for Chip Erase maximum time.</li> <li>6. Added the missing note in <a href="#">Table 54-44. Ultra-Low-Power Internal 32kHz Oscillator Electrical Characteristics</a>.</li> <li>7. Added the missing note in <a href="#">Table 54-48. Fractional Digital Phase Lock Loop Characteristics</a></li> <li>8. Typo for the maximum value of tMOH in the <a href="#">Table 54-51. SPI Timing Characteristics and Requirements</a> addressed.</li> <li>9. <a href="#">Table 54-53. QSPI Maximum Frequency</a> examples updated.</li> </ol>
<a href="#">Electrical Characteristics at 105°C</a>	Introduced device part numbers with Electrical Characteristics for 105°C temperature grade.
<a href="#">Electrical Characteristics at 125°C</a>	Introduced device part numbers with Electrical Characteristics for 125°C temperature grade.

**Table 62-4. Rev. B - 4/2018**

Section Name or Type	Change Description
<a href="#">Features</a>	<p>Updated CAN FD reference.</p> <p>Added 120-ball TFBGA package.</p>
<a href="#">Configuration Summary</a>	Added 120-ball TFBGA to the family feature tables.
<a href="#">Ordering Information</a>	<p>Updated the notes for devices in WLCSP packages.</p> <p>Updated Package Type, adding CT = TFBGA.</p>

# SAM D5x/E5x Family Data Sheet

## Revision History

.....continued	
Section Name or Type	Change Description
Pinout	Added the 120-ball TFBGA package pinout diagram.
Multiplexed Signals	Added 120-ball TFBGA and updated Note 3 (see <a href="#">Table 6-1</a> ).
OSC32KCTRL - 32 kHz Oscillators Controller	Added the EN1K and EN32K bits to the OSCULP32K register (see <a href="#">29.8.9 OSCULP32K</a> ).
SERCOM - Serial Communication Interface	Added Fractional Baud information to the Baud Rate Equations (see <a href="#">Table 33-2</a> ).
QSPI - Quad Serial Peripheral Interface	Added equations to the BAUD register (see <a href="#">37.8.3 BAUD</a> ).
CAN - Control Area Network	Updated the Overview.  Updated ISO 11898 references throughout the chapter.
Public Key Cryptography Controller (PUKCC)	Added the <a href="#">Public Key Cryptography Library (PUKCL) Application Programmer Interface (API)</a> section.
TCC - Timer/Counter for Control Applications	Updated the number of TCC instances to 5 (4:0).
54. Electrical Characteristics at 85°C	(1) Improved SPI maximum speed information in <a href="#">Table 54-56</a> . (2). Added example for QSPI maximum frequency examples <a href="#">Table 54-58</a> .
Packaging Information	Added the 120-ball TFBGA package (see <a href="#">58.3.8 120-ball TFBGA</a> ).

**Table 62-5. Rev. A - 07/2017**

This is the initial release of the document.

## The Microchip Web Site

---

Microchip provides online support via our web site at <http://www.microchip.com/>. This web site is used as a means to make files and information easily available to customers. Accessible by using your favorite Internet browser, the web site contains the following information:

- **Product Support** – Data sheets and errata, application notes and sample programs, design resources, user's guides and hardware support documents, latest software releases and archived software
- **General Technical Support** – Frequently Asked Questions (FAQ), technical support requests, online discussion groups, Microchip consultant program member listing
- **Business of Microchip** – Product selector and ordering guides, latest Microchip press releases, listing of seminars and events, listings of Microchip sales offices, distributors and factory representatives

## Customer Change Notification Service

---

Microchip's customer notification service helps keep customers current on Microchip products. Subscribers will receive e-mail notification whenever there are changes, updates, revisions or errata related to a specified product family or development tool of interest.

To register, access the Microchip web site at <http://www.microchip.com/>. Under "Support", click on "Customer Change Notification" and follow the registration instructions.

## Customer Support

---

Users of Microchip products can receive assistance through several channels:

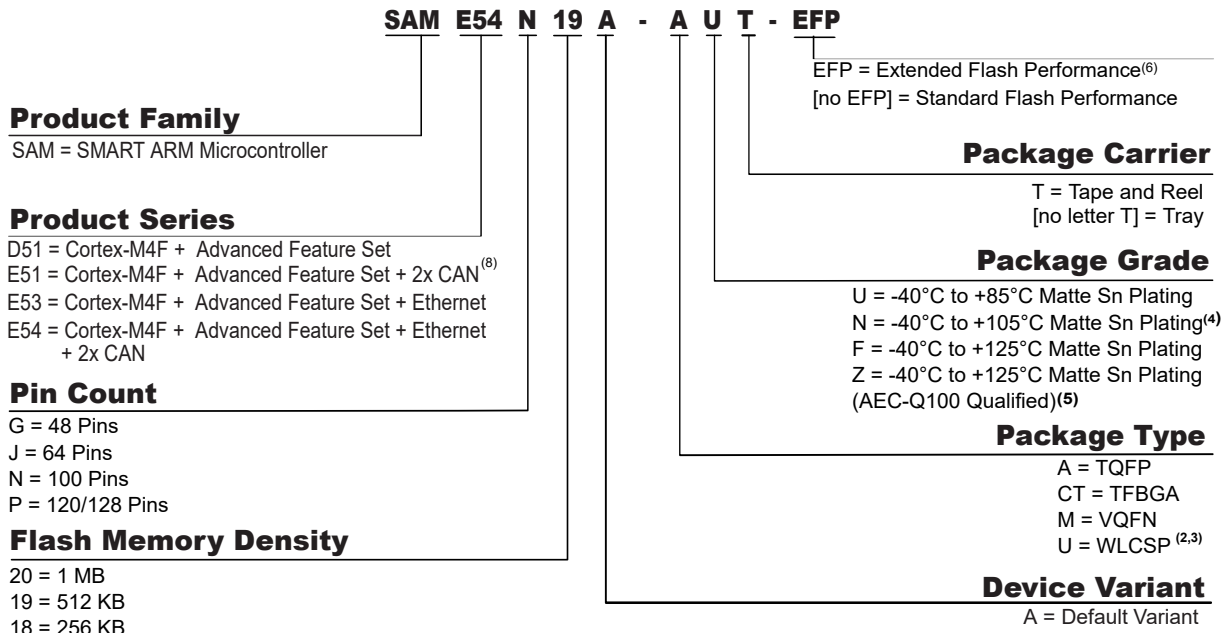
- Distributor or Representative
- Local Sales Office
- Field Application Engineer (FAE)
- Technical Support

Customers should contact their distributor, representative or Field Application Engineer (FAE) for support. Local sales offices are also available to help customers. A listing of sales offices and locations is included in the back of this document.

Technical support is available through the web site at: <http://www.microchip.com/support>

## Product Identification System

To order or obtain information, e.g., on pricing or delivery, refer to the factory or the listed sales office.



## Microchip Devices Code Protection Feature

Note the following details of the code protection feature on Microchip devices:

- Microchip products meet the specification contained in their particular Microchip Data Sheet.
- Microchip believes that its family of products is one of the most secure families of its kind on the market today, when used in the intended manner and under normal conditions.
- There are dishonest and possibly illegal methods used to breach the code protection feature. All of these methods, to our knowledge, require using the Microchip products in a manner outside the operating specifications contained in Microchip's Data Sheets. Most likely, the person doing so is engaged in theft of intellectual property.
- Microchip is willing to work with the customer who is concerned about the integrity of their code.
- Neither Microchip nor any other semiconductor manufacturer can guarantee the security of their code. Code protection does not mean that we are guaranteeing the product as "unbreakable."

Code protection is constantly evolving. We at Microchip are committed to continuously improving the code protection features of our products. Attempts to break Microchip's code protection feature may be a violation of the Digital Millennium Copyright Act. If such acts allow unauthorized access to your software or other copyrighted work, you may have a right to sue for relief under that Act.

## Legal Notice

Information contained in this publication regarding device applications and the like is provided only for your convenience and may be superseded by updates. It is your responsibility to ensure that your

application meets with your specifications. MICROCHIP MAKES NO REPRESENTATIONS OR WARRANTIES OF ANY KIND WHETHER EXPRESS OR IMPLIED, WRITTEN OR ORAL, STATUTORY OR OTHERWISE, RELATED TO THE INFORMATION, INCLUDING BUT NOT LIMITED TO ITS CONDITION, QUALITY, PERFORMANCE, MERCHANTABILITY OR FITNESS FOR PURPOSE.

Microchip disclaims all liability arising from this information and its use. Use of Microchip devices in life support and/or safety applications is entirely at the buyer's risk, and the buyer agrees to defend, indemnify and hold harmless Microchip from any and all damages, claims, suits, or expenses resulting from such use. No licenses are conveyed, implicitly or otherwise, under any Microchip intellectual property rights unless otherwise stated.

## Trademarks

---

The Microchip name and logo, the Microchip logo, AnyRate, AVR, AVR logo, AVR Freaks, BitCloud, chipKIT, chipKIT logo, CryptoMemory, CryptoRF, dsPIC, FlashFlex, flexPWR, Heldo, JukeBlox, KeeLoq, Klear, LANCheck, LINK MD, maXStylus, maXTouch, MediaLB, megaAVR, MOST, MOST logo, MPLAB, OptoLyzer, PIC, picoPower, PICSTART, PIC32 logo, Prochip Designer, QTouch, SAM-BA, SpyNIC, SST, SST Logo, SuperFlash, tinyAVR, UNI/O, and XMEGA are registered trademarks of Microchip Technology Incorporated in the U.S.A. and other countries.

ClockWorks, The Embedded Control Solutions Company, EtherSynch, Hyper Speed Control, HyperLight Load, IntelliMOS, mTouch, Precision Edge, and Quiet-Wire are registered trademarks of Microchip Technology Incorporated in the U.S.A.

Adjacent Key Suppression, AKS, Analog-for-the-Digital Age, Any Capacitor, AnyIn, AnyOut, BodyCom, CodeGuard, CryptoAuthentication, CryptoAutomotive, CryptoCompanion, CryptoController, dsPICDEM, dsPICDEM.net, Dynamic Average Matching, DAM, ECAN, EtherGREEN, In-Circuit Serial Programming, ICSP, INICnet, Inter-Chip Connectivity, JitterBlocker, KlearNet, KlearNet logo, memBrain, Mindi, MiWi, motorBench, MPASM, MPF, MPLAB Certified logo, MPLIB, MPLINK, MultiTRAK, NetDetach, Omniscient Code Generation, PICDEM, PICDEM.net, PICkit, PICtail, PowerSmart, PureSilicon, QMatrix, REAL ICE, Ripple Blocker, SAM-ICE, Serial Quad I/O, SMART-I.S., SQI, SuperSwitcher, SuperSwitcher II, Total Endurance, TSHARC, USBCheck, VariSense, ViewSpan, WiperLock, Wireless DNA, and ZENA are trademarks of Microchip Technology Incorporated in the U.S.A. and other countries.

SQTP is a service mark of Microchip Technology Incorporated in the U.S.A.

Silicon Storage Technology is a registered trademark of Microchip Technology Inc. in other countries.

GestIC is a registered trademark of Microchip Technology Germany II GmbH & Co. KG, a subsidiary of Microchip Technology Inc., in other countries.

All other trademarks mentioned herein are property of their respective companies.

© 2018, Microchip Technology Incorporated, Printed in the U.S.A., All Rights Reserved.

ISBN: 978-1-5224-4642-2

## Quality Management System Certified by DNV

---

### ISO/TS 16949

Microchip received ISO/TS-16949:2009 certification for its worldwide headquarters, design and wafer fabrication facilities in Chandler and Tempe, Arizona; Gresham, Oregon and design centers in California and India. The Company's quality system processes and procedures are for its PIC<sup>®</sup> MCUs and dsPIC<sup>®</sup> DSCs, KEELOQ<sup>®</sup> code hopping devices, Serial EEPROMs, microperipherals, nonvolatile memory and

# SAM D5x/E5x Family Data Sheet

---

analog products. In addition, Microchip's quality system for the design and manufacture of development systems is ISO 9001:2000 certified.



## Worldwide Sales and Service

AMERICAS	ASIA/PACIFIC	ASIA/PACIFIC	EUROPE
<p><b>Corporate Office</b> 2355 West Chandler Blvd. Chandler, AZ 85224-6199 Tel: 480-792-7200 Fax: 480-792-7277 Technical Support: <a href="http://www.microchip.com/support">http://www.microchip.com/support</a> Web Address: <a href="http://www.microchip.com">www.microchip.com</a></p> <p><b>Atlanta</b> Duluth, GA Tel: 678-957-9614 Fax: 678-957-1455</p> <p><b>Austin, TX</b> Tel: 512-257-3370</p> <p><b>Boston</b> Westborough, MA Tel: 774-760-0087 Fax: 774-760-0088</p> <p><b>Chicago</b> Itasca, IL Tel: 630-285-0071 Fax: 630-285-0075</p> <p><b>Dallas</b> Addison, TX Tel: 972-818-7423 Fax: 972-818-2924</p> <p><b>Detroit</b> Novi, MI Tel: 248-848-4000</p> <p><b>Houston, TX</b> Tel: 281-894-5983</p> <p><b>Indianapolis</b> Noblesville, IN Tel: 317-773-8323 Fax: 317-773-5453 Tel: 317-536-2380</p> <p><b>Los Angeles</b> Mission Viejo, CA Tel: 949-462-9523 Fax: 949-462-9608 Tel: 951-273-7800</p> <p><b>Raleigh, NC</b> Tel: 919-844-7510</p> <p><b>New York, NY</b> Tel: 631-435-6000</p> <p><b>San Jose, CA</b> Tel: 408-735-9110 Tel: 408-436-4270</p> <p><b>Canada - Toronto</b> Tel: 905-695-1980 Fax: 905-695-2078</p>	<p><b>Australia - Sydney</b> Tel: 61-2-9868-6733</p> <p><b>China - Beijing</b> Tel: 86-10-8569-7000</p> <p><b>China - Chengdu</b> Tel: 86-28-8665-5511</p> <p><b>China - Chongqing</b> Tel: 86-23-8980-9588</p> <p><b>China - Dongguan</b> Tel: 86-769-8702-9880</p> <p><b>China - Guangzhou</b> Tel: 86-20-8755-8029</p> <p><b>China - Hangzhou</b> Tel: 86-571-8792-8115</p> <p><b>China - Hong Kong SAR</b> Tel: 852-2943-5100</p> <p><b>China - Nanjing</b> Tel: 86-25-8473-2460</p> <p><b>China - Qingdao</b> Tel: 86-532-8502-7355</p> <p><b>China - Shanghai</b> Tel: 86-21-3326-8000</p> <p><b>China - Shenyang</b> Tel: 86-24-2334-2829</p> <p><b>China - Shenzhen</b> Tel: 86-755-8864-2200</p> <p><b>China - Suzhou</b> Tel: 86-186-6233-1526</p> <p><b>China - Wuhan</b> Tel: 86-27-5980-5300</p> <p><b>China - Xian</b> Tel: 86-29-8833-7252</p> <p><b>China - Xiamen</b> Tel: 86-592-2388138</p> <p><b>China - Zhuhai</b> Tel: 86-756-3210040</p>	<p><b>India - Bangalore</b> Tel: 91-80-3090-4444</p> <p><b>India - New Delhi</b> Tel: 91-11-4160-8631</p> <p><b>India - Pune</b> Tel: 91-20-4121-0141</p> <p><b>Japan - Osaka</b> Tel: 81-6-6152-7160</p> <p><b>Japan - Tokyo</b> Tel: 81-3-6880-3770</p> <p><b>Korea - Daegu</b> Tel: 82-53-744-4301</p> <p><b>Korea - Seoul</b> Tel: 82-2-554-7200</p> <p><b>Malaysia - Kuala Lumpur</b> Tel: 60-3-7651-7906</p> <p><b>Malaysia - Penang</b> Tel: 60-4-227-8870</p> <p><b>Philippines - Manila</b> Tel: 63-2-634-9065</p> <p><b>Singapore</b> Tel: 65-6334-8870</p> <p><b>Taiwan - Hsin Chu</b> Tel: 886-3-577-8366</p> <p><b>Taiwan - Kaohsiung</b> Tel: 886-7-213-7830</p> <p><b>Taiwan - Taipei</b> Tel: 886-2-2508-8600</p> <p><b>Thailand - Bangkok</b> Tel: 66-2-694-1351</p> <p><b>Vietnam - Ho Chi Minh</b> Tel: 84-28-5448-2100</p>	<p><b>Austria - Wels</b> Tel: 43-7242-2244-39 Fax: 43-7242-2244-393</p> <p><b>Denmark - Copenhagen</b> Tel: 45-4450-2828 Fax: 45-4485-2829</p> <p><b>Finland - Espoo</b> Tel: 358-9-4520-820</p> <p><b>France - Paris</b> Tel: 33-1-69-53-63-20 Fax: 33-1-69-30-90-79</p> <p><b>Germany - Garching</b> Tel: 49-8931-9700</p> <p><b>Germany - Haan</b> Tel: 49-2129-3766400</p> <p><b>Germany - Heilbronn</b> Tel: 49-7131-67-3636</p> <p><b>Germany - Karlsruhe</b> Tel: 49-721-625370</p> <p><b>Germany - Munich</b> Tel: 49-89-627-144-0 Fax: 49-89-627-144-44</p> <p><b>Germany - Rosenheim</b> Tel: 49-8031-354-560</p> <p><b>Israel - Ra'anana</b> Tel: 972-9-744-7705</p> <p><b>Italy - Milan</b> Tel: 39-0331-742611 Fax: 39-0331-466781</p> <p><b>Italy - Padova</b> Tel: 39-049-7625286</p> <p><b>Netherlands - Druenen</b> Tel: 31-416-690399 Fax: 31-416-690340</p> <p><b>Norway - Trondheim</b> Tel: 47-72884388</p> <p><b>Poland - Warsaw</b> Tel: 48-22-3325737</p> <p><b>Romania - Bucharest</b> Tel: 40-21-407-87-50</p> <p><b>Spain - Madrid</b> Tel: 34-91-708-08-90 Fax: 34-91-708-08-91</p> <p><b>Sweden - Gothenberg</b> Tel: 46-31-704-60-40</p> <p><b>Sweden - Stockholm</b> Tel: 46-8-5090-4654</p> <p><b>UK - Wokingham</b> Tel: 44-118-921-5800 Fax: 44-118-921-5820</p>