

268
HANDHELD CASES

292
UNIVERSAL
ENCLOSURES

318
HEAVY DUTY
AND ELECTRICAL
ENCLOSURES

342
DESKTOP AND
INSTRUMENT
CASES

348
DEVELOPMENT
BOARD
ENCLOSURES

367
ROOM SENSOR
ENCLOSURES

370
CUSTOM SIZED
ENCLOSURES

7740 series screw fastening wall mount enclosures

Product overview

Wall mounted enclosures with two compartments, equipped with covers. Designed to house electronic applications.

- Moulded in high quality ABS
- Suitable for high temperatures
- Protects controls and components indoors or outdoors
- Fastening pillars and guide grooves for Vertical and horizontal PCB mounting
- DIN Rail mountable
- EPDM gasket for IP65 seal pre-installed
- 7740 series has been designed to meet the requirements of IP65

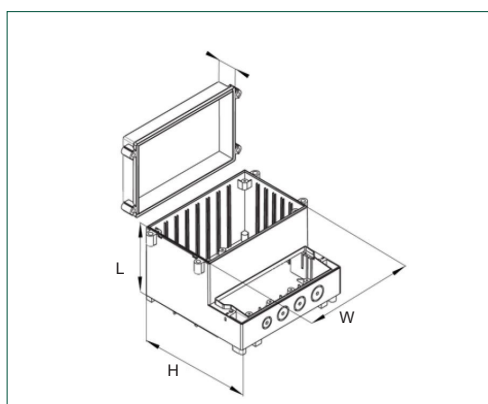

SPECIFICATION

| | |
|------------------------|--|
| Materials | Lid and base ABS, UL94-HB |
| Operating temperature | -40°C to +80°C |
| Protection class | 7740 series has been designed to meet the requirements of IP65 |
| Standard colours | Light grey, similar to RAL 7035 |
| Standard unit includes | Box, lid, fixing screws and neoprene gasket |

| PART NO. | LENGTH | WIDTH | HEIGHT |
|-----------|---------|-------|--------|
| CHD774001 | 93mm | 166mm | 161mm |
| CHD774002 | 121mm | 166mm | 161mm |
| CHD774003 | 104.5mm | 213mm | 185mm |
| CHD774004 | 132.5mm | 256mm | 217mm |
| CHD774005 | 158mm | 296mm | 281mm |

ACCESSORIES

Wall mounting kit



| PART NO. | DESCRIPTION |
|-----------|-------------------|
| CHD7700MK | Mounting brackets |

KEY FEATURES

EPDM gasket | five sizes | DIN Rail mountable

