

10mm ENCLOSED CARBON PRESET

QUICK REFERENCE DATA

Resistance range (E3-series), linear law, log law on request	100 Ω to 4,7 M Ω *
Maximum dissipation	
at 40 °C	0,1 W
at 70 °C	0,05 W
at 85 °C	0,025 W
Temperature coefficient (range 1 k Ω to 2,2 M Ω)	$\pm 300 \cdot 10^{-6} / K$
Climatic category, IEC 68-2	25/085/10

DESCRIPTION

These preset potentiometers comprise a carbon resistive element on a phenolic paper base. The actuating device is a plastic rotor or a metal wiper. Adjustment is by means of cross or hexagonal slots. The overall width of 9,8 mm allows for high density use with air-gap isolation on a 2,5 mm grid; either horizontal or vertical mounting. The black glass-filled synthetic resin housing is fire resistant. The potentiometers, which are manufactured and tested fully automatically, offer stable, high quality performance and can be mounted by automatic insertion machines.

They are designed for video, audio and industrial applications and are especially suited for equipment in which automatic placement and adjustment is practised. Versions are available with a hexagonal slotted plastic rotor, which can accept a knob to facilitate manual adjustment.

The terminals a and c are the end terminals; b is the central terminal connected to the slider. All terminals are either straight or snap-in pins for mounting on printed-wiring boards of nominal 1,0 to 1,6 mm thickness, grid pitch 2,5 or 2,54 mm.

Special straight terminals are available for automatic insertion.

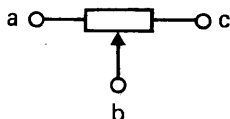

Terminal designation.

7Z85818

MECHANICAL DATA

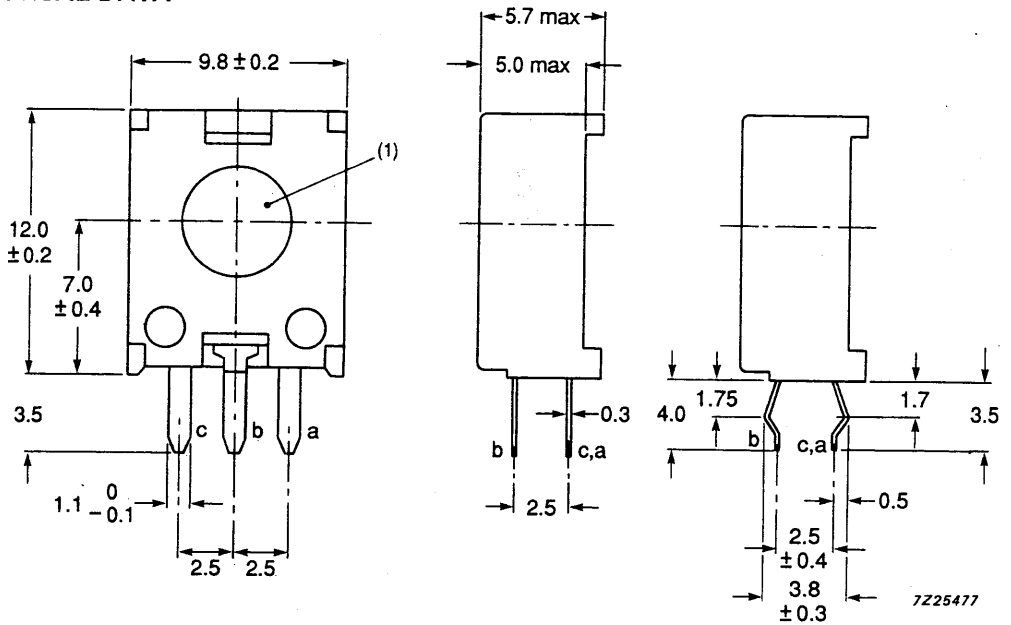

Fig. 1 Vertical mounting.

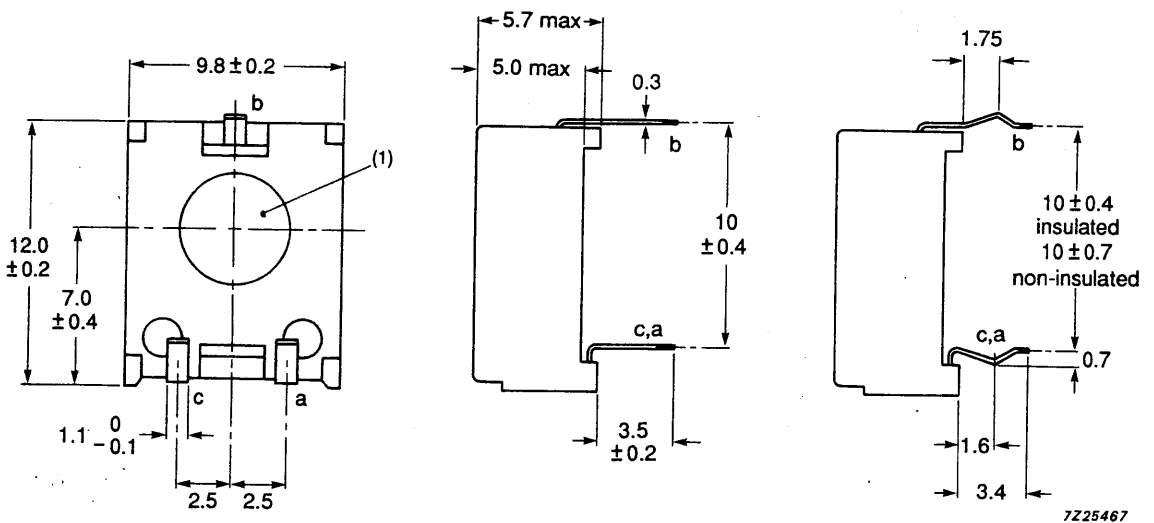

Fig. 2 Horizontal mounting.

Note: Snap-in terminals are designed for 1,6 mm PC boards.

Note to mechanical data

1. For details of available slots (cross, hexagonal, insulated or non-insulated wiper), see Figs 3, 4 and 5.

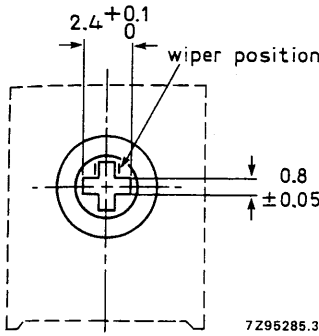

Fig. 3 Cross slot, non-insulated wiper for vertical and horizontal versions; straight pins only.

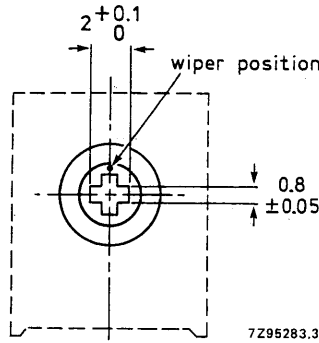

Fig. 4 Cross slot, insulated wiper for vertical and horizontal versions.

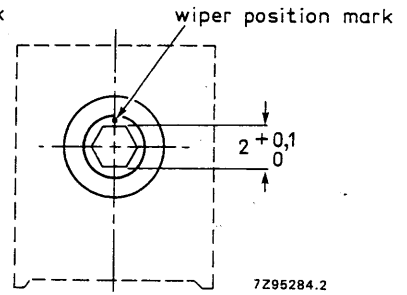

Fig. 5 Hexagonal slot, insulated wiper for vertical and horizontal versions.

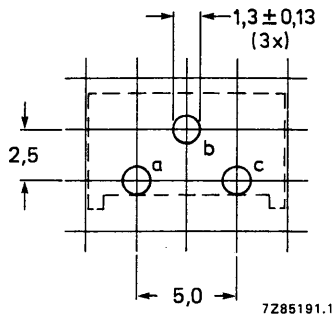

Fig. 6 Hole pattern for vertical versions, viewed from component side.

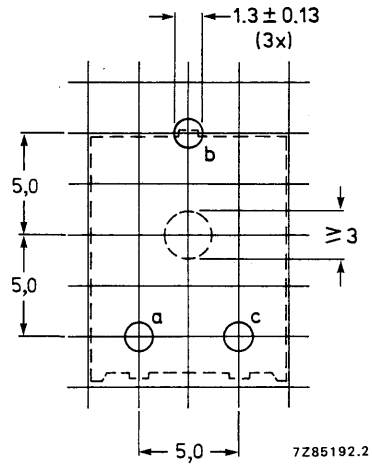

Fig. 7 Hole pattern for horizontal versions, viewed from component side.

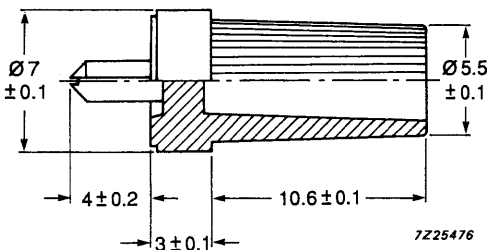

Fig. 8 Example of a knob for versions with a hexagonal slot and coloured black (cat. no. 4322 052 70720). Other colours are available on request.

TECHNICAL DATA

Mass		~ 0,6 g
Resistance range (E3-series)		100 Ω to 4,7 M Ω
Standard tolerance		$\pm 20\%$ and $\pm 10\%$
Resistance law		linear, see Fig. 9
Rated dissipation at 40 °C (P_{\max})		0,1 W, see Fig. 8
Limiting element voltage		200 V (DC or AC)
Limiting wiper current (DC or AC)		$\sqrt{\frac{P_{\max}}{R_{\text{nom}}}}$
Minimum effective resistance		$\leq 2\%$ of R_{ac} or 10 Ω , whichever is greater
Rotational noise limits (contact resistance variation)		$\leq 1,0\%$ of R_{nom} (0 to top)
Operating torque		2 to 10 mNm
Permissible end-stop torque		max. 50 mNm
Total mechanical angle of rotation		300 $\pm 5^\circ$
Effective angle of rotation		285 $\pm 10^\circ$
Settability		0,2% within 20 s
Climatic category according to IEC 68–2		25/085/10
Climatic sequence	$\frac{\Delta R_{\text{ac}}}{R_{\text{ac}}}$	$\leq \pm 10\%$
Damp heat, steady state, with or without load, between a and c, 10 days	$\frac{\Delta R_{\text{ac}}}{R_{\text{ac}}}$	$\leq 10\%$
Mechanical endurance (200 cycles)	$\frac{\Delta R_{\text{ac}}}{R_{\text{ac}}}$	$\leq 10\%$
Electrical endurance (1000 hours at 70 °C, cyclic, loaded between a and c)	$\frac{\Delta R_{\text{ac}}}{R_{\text{ac}}}$	$\leq \pm 10\%$
Resistance to soldering heat	$\frac{\Delta R_{\text{ac}}}{R_{\text{ac}}}$	$\leq \pm 2\%$
Bump	$\frac{\Delta R_{\text{ac}}}{R_{\text{ac}}}$	$\leq \pm 2\%$
Vibration	$\frac{\Delta R_{\text{ac}}}{R_{\text{ac}}}$	$\leq \pm 2\%$
	$\frac{\Delta V_{\text{ab}}}{V_{\text{ac}}}$	$\leq 0,5\%$

DERATING

Potentiometers covered by this specification are derated from 100% rated dissipation at 40 °C to 25% dissipation at 85 °C. The dissipation below 40 °C is the rated dissipation.

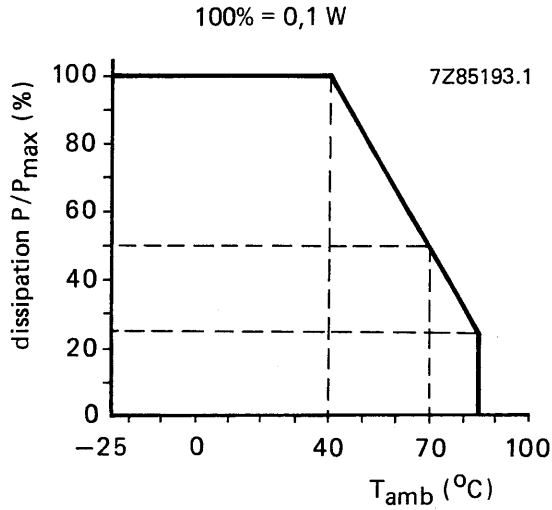

Fig. 9 Dissipation as a function of ambient temperature.

RESISTANCE

Potentiometers covered by this specification are linear.

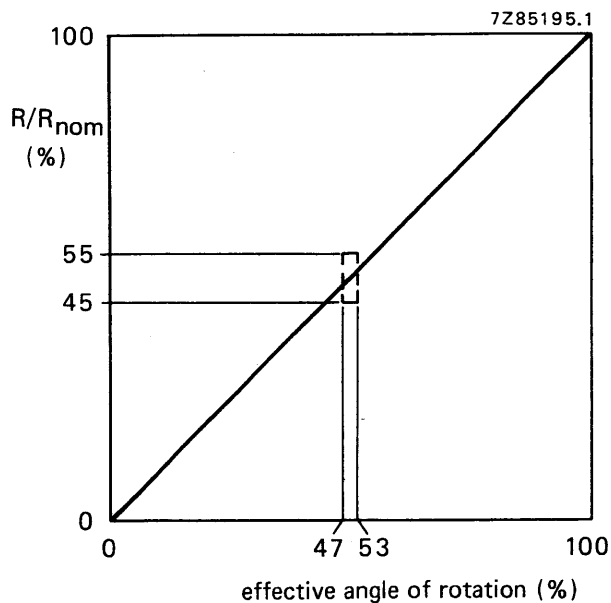

Fig. 10 Linear resistance law.

PRODUCT MARKING

The potentiometers are marked with the rated resistance, according to IEC 62, e.g. $220 \Omega = 220 R$; $10 \text{ k}\Omega = 10K$; $1 \text{ M}\Omega = 1M0$.

PACKAGING

The potentiometers can be supplied in bulk packaging of 1000 in a cardboard box or, especially for automatic insertion, in anti-static rail packaging of 50 per rail, 20 rails in a box. The outside dimensions of the rails, which have rubber stops at both ends, one grey and one black, are given in Fig. 11.

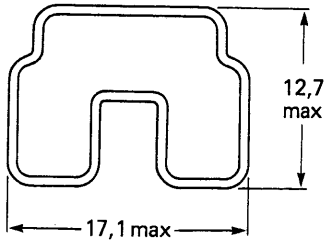

For horizontal versions.

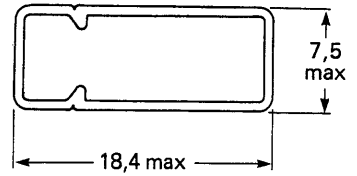

For vertical versions.

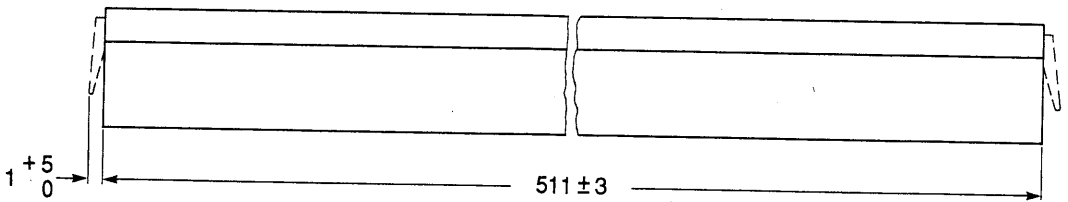

7Z25478

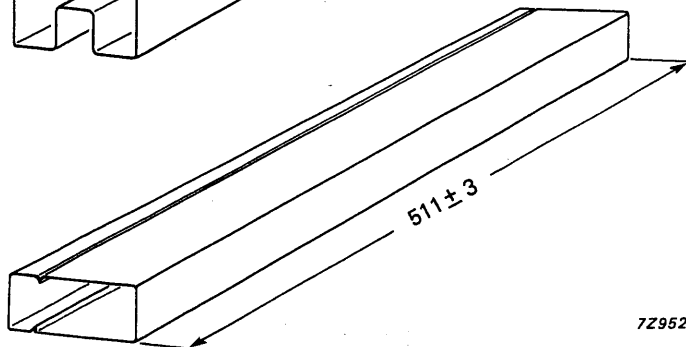
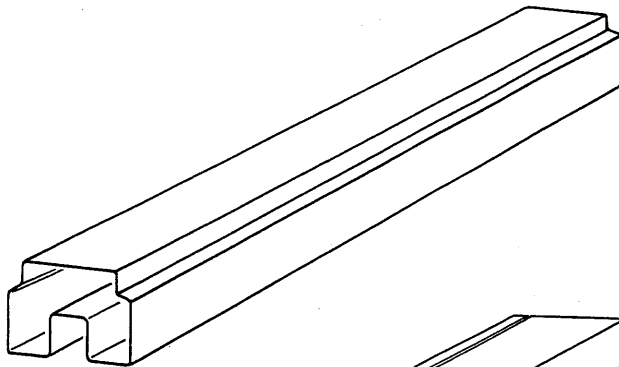

7Z95282.2

Fig. 11 Outlines of the rail packaging.

PACKAGING MARKING

The package containing the potentiometer has a main label as shown in Fig. 12 and an additional label if the products have CECC approval as shown in Fig 13.

Data on the main label is as follows:

Field 1 : Country of origin

Field 2: Product family and
Resistance value

Field 3: Product description
(30 positions)

Field 4: Customer code
(on request)

Field 5: Preference origin code and
production centre

Field 6: Quantity per PC and
Production code

Field 7: Product description
(5 positions)

Field 8: Code number

MADE IN BELGIUM
POTENTIOMETERS 47K A
ECP10 ENCLOSED CARBON PRESET



Fig. 12 Package label.

PHILIPS



PHILIPS



CECC 41102-002



CECC 41102-002

Fig. 13 Label for CECC approved products.

COMPOSITION OF THE CATALOGUE NUMBER

2322 483

code for version

- 0 = vertical, non-insulated cross slot *
- 1 = vertical, insulated hexagonal slot
- 2 = vertical, insulated cross slot
- 5 = horizontal, non-insulated cross slot
- 6 = horizontal, insulated hexagonal slot
- 7 = horizontal, insulated cross slot

code for tolerance, tags, packaging

- 2 = ± 20%, snap-in pins, bulk packaging
- 3 = ± 10%, snap-in pins, bulk packaging
- 4 = ± 20%, straight pins, bulk packaging
- 5 = ± 10%, straight pins, bulk packaging
- 6 = ± 20%, snap-in pins, rail packaging
- 7 = ± 10%, snap-in pins, rail packaging
- 8 = ± 20%, straight pins, rail packaging
- 9 = ± 10%, straight pins, rail packaging

resistance code **

- 101 = 100 Ω
- 221 = 220 Ω
- 471 = 470 Ω
- 102 = 1 kΩ
- 222 = 2,2 kΩ
- 472 = 4,7 kΩ
- 103 = 10 kΩ
- 223 = 22 kΩ
- 473 = 47 kΩ
- 104 = 100 kΩ
- 224 = 220 kΩ
- 474 = 470 kΩ
- 105 = 1 MΩ
- 225 = 2,2 MΩ
- 475 = 4,7 MΩ

* Snap in terminals on request

** log versions on request.

TESTS AND REQUIREMENTS

Clause numbers of tests and conditions of test refer to IEC 393–1 (potentiometers, part 1: terms and methods of test).

The potentiometers have been tested whilst mounted by their terminations on a printed wiring board.

When drying is called for procedure I of IEC 393–1, sub. 5.2. is used (24 ± 4 h, 55 ± 2 °C, R.H. 20%).

When the contact resistance variation (CRV) is measured, the wiper is rotated in both directions over 90% of the effective resistance for a total of 6 cycles. The maximum deviations in the last 3 cycles are taken into account. Wiper speed: 2 cycles/minute; bandwidth 10 Hz to 5 kHz.

IEC 393–1 clause	IEC 68–2 test method	test	procedure	typical result
6.22.3	T	Solderability	solder bath: 235 ± 5 °C $2 \pm 0,5$ s	good tinning
6.22.4	Tb	Resistance to heat	solder bath: 350 ± 10 °C $3,5 \pm 0,5$ s	$\frac{\Delta R_{ac}}{R_{ac}} \leq 2\%$ (typ. value $\leq 0,5\%$)
6.25	Eb	Bump	acceleration: 390 m/s ² number of bumps: 4000	$\frac{\Delta R_{ac}}{R_{ac}} \leq 2\%$

IEC 393-1 clause	IEC 68-2 test method	test	procedure	typical result
6.24	Fc	Vibration	frequency: 10 - 500 Hz amplitude: 0,75 mm or 98 m/s ² , 6 h	$\frac{\Delta R_{ac}}{R_{ac}} \leq \pm 2\%$ (typ. value $\leq 0,5\%$) $\frac{\Delta V_{ab}}{V_{ac}} \leq 0,5\%$ (typ. value $\leq 0,3\%$)
6.13		Temperature characteristic of resistance	temp. cycle: + 20 °C; -25 °C; + 20 °C; + 70 °C + 85 °C; + 20 °C	$\pm 500 \cdot 10^{-6}/K$ (100 Ω up to 470 Ω) $\pm 300 \cdot 10^{-6}/K$ (1 kΩ up to 2 MΩ) $\pm 1000 \cdot 10^{-6}/K$ (4,7 MΩ)
6.26 6.26.2 6.26.3 6.26.4 6.26.6	— Ba D Aa D	Climatic sequence Dry heat Damp heat, accel. 1st cycle Cold Damp heat remaining cycle	16 h at 85 °C 24 h at 55 °C 95 - 100% R.H. 2 h at -25 °C 24 h at 55 °C 95 - 100% R.H.	$\left. \begin{array}{l} \Delta R_{ac} \\ R_{ac} \end{array} \right\} \leq \pm 10\%$
(6.30)	—	Electrical endurance	T _{amb} : 70 °C, 1000 h cycle (1,5 h on and 0,5 h off, b at 0,67 a - c) Load: 0,05 W between a and c	CRV < 2% of R _{nom} $\frac{\Delta R_{ac}}{R_{ac}} \leq \pm 10\%$ $R_{ac} \leq \pm 20\%$ up to 4,7 MΩ
6.29	—	Mechanical endurance	200 cycles, 4 cycles/min no load	$\frac{\Delta R_{ac}}{R_{ac}} \leq 10\%$ (typ. value $\leq 5\%$) CRV < 1,0% of R _{nom}
(6.27)	C	Damp heat steady state	10 days; recovery 24 h, 22 ± 1 °C, 50% R.H. ± 5%	CRV < 1,0% of R _{nom} $\frac{\Delta R_{ac}}{R_{ac}} \leq 10\%$ (typ. value $\leq 5\%$) $\frac{\Delta V_{ab}}{V_{ac}} \leq 1\%$ (typ. value $\leq 0,2\%$)