



# Quam

## ATTENUATORS

# QC101

### SINGLE-GANG

UL LISTED, 100W, 10-Step,  
Stainless Steel Faceplate, Embossed Positions

### GENERAL DESCRIPTION

The **QC101** is a UL Listed, single-gang, 100W, ten-step, continuous rotary, audio level attenuator with an OFF position. Brushed, stainless steel faceplate with embossed positions and a black knob with white indicator mark.

### INTENDED USE - Indoor Environment

<b>Primary Use</b>	Attenuates audio power to any number of loudspeakers, up to 100W load. For use with 25V or 70V distributed audio systems.
<b>UL LISTED 813 Commercial Audio Equipment</b>	When installed in accordance with supplied instructions and connected to supply circuits in accordance with ANSI/NFPA70, NEC, and AHJ.
<b>Installation</b>	Single-gang electrical box, 2-1/8"D

### AUDIO SPECIFICATIONS

<b>Power Rating</b>	100W Continuous
<b>Attenuation (Ref: 25V, 70.7V line)</b>	Position 10 : Full Signal Position 9-3 : -3 dB each Positions 2-1 : -6 dB each Position 0 : No Signal
<b>Insertion Loss</b>	<0.5 dB
<b>Audio Connection</b>	10" long, pre-cut, color coded leads

### RECOMMENDED QUAM COMPONENTS

Enclosures | *Surface Mount* : SE4W

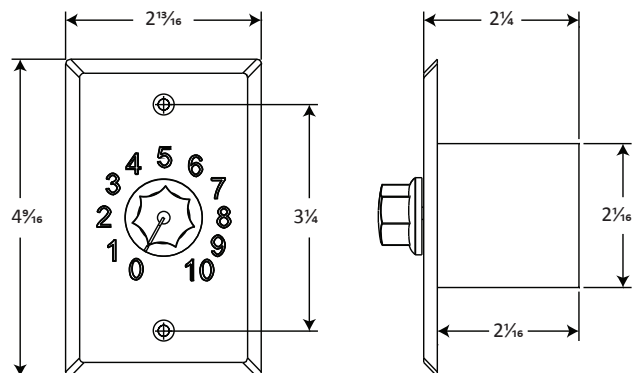

Recommended construction sequences, installation instructions, and A&E Specifications are available in various formats in the Specs and Diagrams section at:  
[www.QuamSpeakers.com](http://www.QuamSpeakers.com)

© 2016 Quam-Nichols Company reserves the right to make changes and/or improvements to its products at any time and without notice.



QUAM-NICHOLS COMPANY, INC.  
234 East Marquette Road. Chicago, IL. 60637  
t: 1-800-NEED-NOW (800-633-3669)  
f: 1-888-NEED-NOW (888-633-3669)  
e: [NeedNow@QNC.com](mailto:NeedNow@QNC.com)  
[www.QuamSpeakers.com](http://www.QuamSpeakers.com)