

ATTENUATORS

QC100RM

RACK MOUNT

UL Listed, 100 Watt, 10-Step



GENERAL DESCRIPTION

The **QC100RM** is a UL Listed, rack mount, 100W, ten-step, continuous rotary, audio level attenuator with an OFF position, and a black knob with white indicator mark. 2" x 2" dial scale label for a 2RU rack panel is included. Legend is white on black.

INTENDED USE - Indoor Environment

Primary Use	Attenuates audio power to any number of loudspeakers, up to 100W load. For use with 25V or 70V distributed audio systems.
UL LISTED 813 Commercial Audio Equipment	When installed in accordance with supplied instructions and connected to supply circuits in accordance with ANSI/NFPA70, NEC, and AHJ.
Installation	2RU rack panel or greater, 1/8" maximum thickness

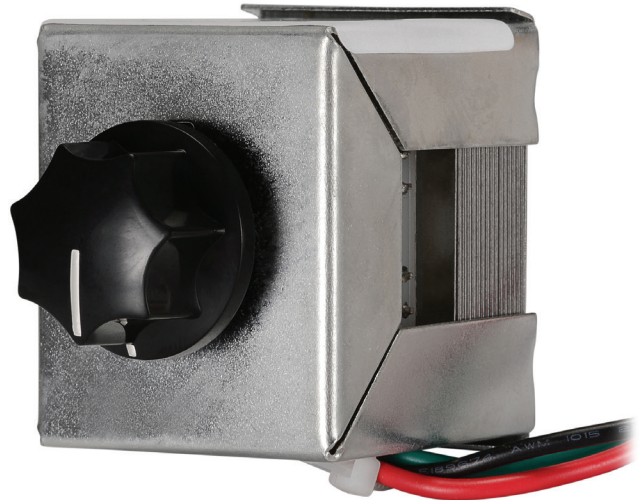

AUDIO SPECIFICATIONS

Power Rating	100W Continuous
Attenuation (Ref: 25V, 70.7V Line)	Position 10 : Full Signal Position 9-3 : -3dB each Position 2-1 : -6 dB each Position 0 : No Signal
Insertion Loss	< 0.5 dB
Audio Connection	10" long, pre-cut, color coded leads

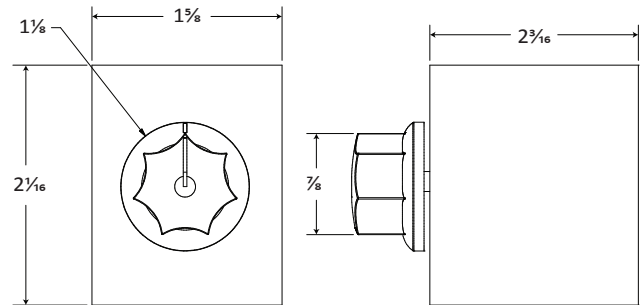

Recommended construction sequences, installation instructions, and A&E Specifications are available in various formats in the Specs and Diagrams section at:
www.QuamSpeakers.com

© 2016 Quam-Nichols Company reserves the right to make changes and/or improvements to its products at any time and without notice.



QUAM-NICHOLS COMPANY, INC.
234 East Marquette Road. Chicago, IL. 60637
t: 1-800-NEED-NOW (800-633-3669)
f: 1-888-NEED-NOW (888-633-3669)
e: NeedNow@QNC.com
www.QuamSpeakers.com