

# Ultra-Broadband Silicon Capacitor UBSC723.510 (10nF / 0201 / BV=30V)

Rev 1.5

TD

## General description

**Market:** UBSC Capacitor targets Optical communication system such as ROSA/TOSA, SONET and all optoelectronics as well as High speed data system or products.

The UBSC is suitable for DC blocking, feedback, coupling and bypassing applications in all broadband optoelectronics and High-speed data system.

The unique technology of integrated passive device in silicon, developed by Murata<sup>(\*)</sup>, offers unique performances with low insertion loss, low reflection and phase stability from 160 KHz to 60 GHz.

These Ultra Broad band MOS Silicon Capacitors (UBSC) in silicon have been developed in a semiconductor process, in order to combine ultra-deep trench MOS capacitors for high capacitance value of 10 nF (for kHz–MHz range) and high frequency MIM capacitors for low capacitance value for GHz range), both in a SMT 0201.

The UBSC capacitor provides very high stability of the capacitance over temperature, voltage variation as well as a very high reliability.

UBSC capacitors have an extended operating temperature ranging from -55 to 150°C, with very low capacitance change over temperature (+/-0.5%).

**Assembly:** Flip chip or embedded applications through existing laminated packages (LGA, BGA) or rigid PCB, FR4 or flex platforms.

Copper pads optional for embedding.

## Key features

- Ultra-broadband performance to 60 GHz
- Resonance free
- Phase stability
- Insertion low < 0.5dB up to 50GHz
- Ultra high stability of capacitance value:
  - ◆ Temperature  $\pm 0.5\%$  (-55 °C to +150 °C)
  - ◆ Voltage <0.1%/Volts
  - ◆ Negligible capacitance loss through ageing
- Low profile: 400µm, 100 µm on request
- Break down voltage > 30V
- Low leakage current < 70pA
- High reliability
- High operating temperature (up to 150 °C)
- Compatible with high temperature cycling during manufacturing operations (exceeding 300 °C)
- Compatible with EIA 0201 footprint

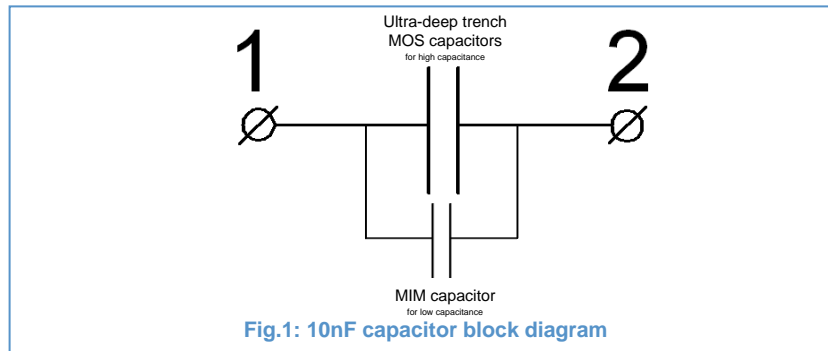
## Key applications

- ROSA/TOSA
- SONET
- High speed digital logic
- Microwave/millimeter system
- Volume limited applications
- Broadband test equipment

(\*) Murata Integrated Passive Solutions

## Functional diagram

The next figure provides implementation set-up of the capacitor (2 connections).



## Electrical performances

### Performances summary

*In accordance with the Absolute Maximum Rating System (IEC 60134).*

Symbol	Parameter	Conditions	Min.	Typ.	Max.	Unit
C	Capacitance value		-	10	-	nF
$\Delta C_P$	Capacitance tolerance		-15	-	+15 <sup>(*)</sup>	%
T <sub>OP</sub>	Operating temperature		-55	20	150	°C
T <sub>STG</sub>	Storage temperature <sup>(**)</sup>		-70	-	165	°C
$\Delta C_T$	Capacitance temperature variation	-55 °C to 150 °C	-0.5	-	+0.5	%
BV	Break down voltage	@25°C	30	-	-	V
RV <sub>DC</sub>	Rated voltage		-	10	16 <sup>(***)</sup> 14.7 <sup>(****)</sup>	V <sub>DC</sub>
$\Delta C_{RVDC}$	Capacitance voltage variation	From 0 V to RV <sub>DC</sub>	-	-	0.1	%/V <sub>DC</sub>
IR	Insulation resistor		-	10	-	GΩ
Fc-3db	Cut-off frequency at 3dB		-	-	160	KHz
IL	Insertion loss	@ 20 GHz	-	-	0.2	dB
		@ 40GHz	-	-	0.3	dB
		@ 60 GHz	-	-	1	dB
RL	Return loss	Up to 60 GHz	14	-	-	dB

**Table1: 10nF capacitor performances**

(\*): Other capacitance tolerances upon request.

(\*\*): component without packing.

(\*\*\*): 10 years of intrinsic life time predictions at 100°C.

(\*\*\*\*): 10 years of intrinsic life time predictions at 150°C.

### Module S-parameters of 10nF UBSC in transmission mode

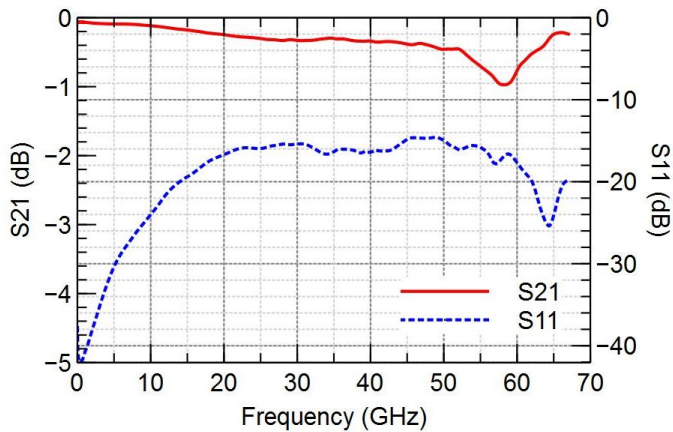
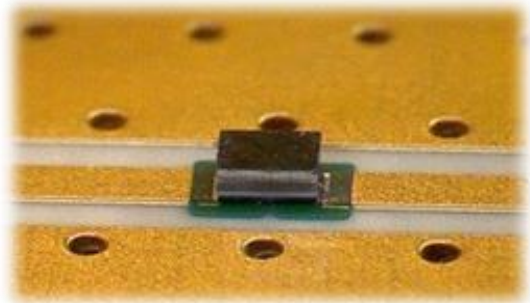


Fig.2 10nF UBSC measurement results (module of S-parameters)

### Test bench



6.6-mils Rogers 4350B.  
Nominal Pad dimensions – pad length = 0.150 mm, pad width and line width = 0.400 mm, pad gap = 0.300 mm

Fig. 3 test bench picture used for 10nF UBSC characterization

### Capacitance variation versus DC biasing

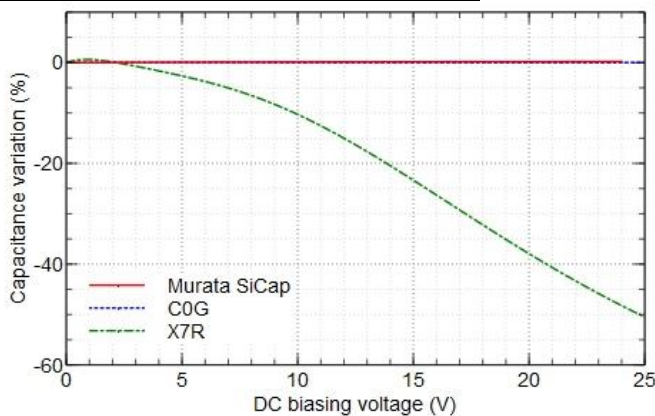


Fig. 4 Capacitance variation versus DC biasing (in function of UBSC and MLCC technology)

### Capacitance variation versus operating temperature

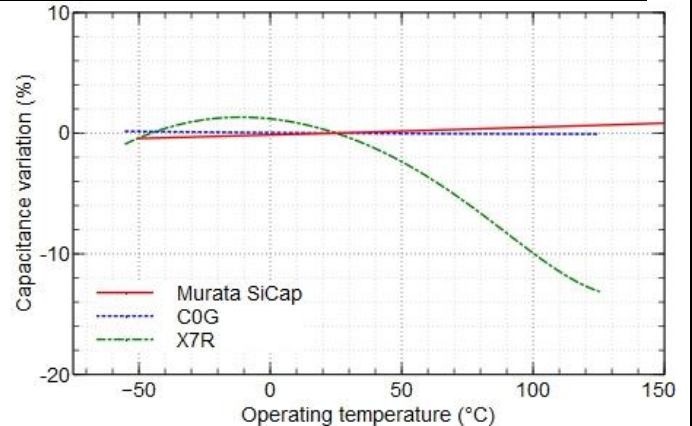


Fig.5 Capacitance variation versus operating temperature (in function of UBSC and MLCC technology)

### Failure Predictions

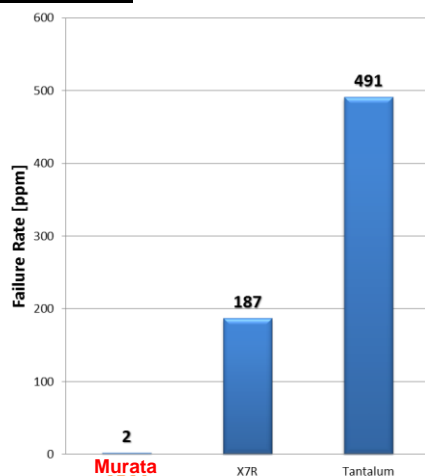


Fig. 6 Projected capacitor Failure Rate in 10 Years at 85°C and 50% of the Rating voltage (in function of UBSC, tantalum and MLCC technology)

### Schematic of 10nF UBSC in transmission mode

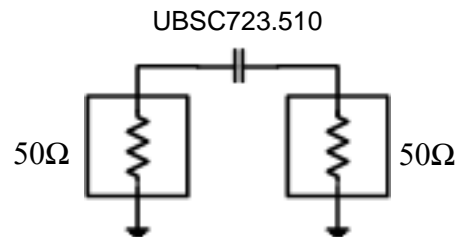
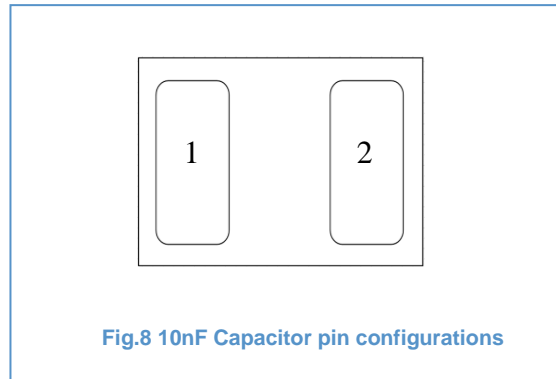


Fig.7 10nF UBSC measurement schematic

## Pinning definition



pin #	Symbol	Description
1	Signal1	Signal
2	Signal2	Signal

Table 2: Pin description

## Ordering information

Type number	Package		
	P/N	Die name	Description
935 151 723 510	UBSC723.510	-	10nF /0201/BV>30V – 2 pads – 0.8 x 0.6 x 0.40 mm <sup>(*)</sup>
935 152 723 510	UBSC723.510	-	10nF /0201/BV>30V – 2 pads – 0.8 x 0.6 x 0.10 mm <sup>(*)</sup>

Table 3: Die information

(\*): Capacitor die dimension: 0.76 x 0.56 mm (without scribe line)  
 Capacitor die size after sawing : 0.8 x 0.6 mm  
 Scribe line = 100µm (saw lane currently used = 60µm)

Type number	Package			
	Packing	Finishing	Description	Version
935 151 723 510-F1N	6" film frame carrier (***)	ENIG(**)	0201 - 10nF – 2 pads – 0.8 x 0.6 mm x 0.40mm	1
935 151 723 510-T3N	T&R 1 000units	ENIG(**)	0201 - 10nF – 2 pads – 0.8 x 0.6 mm x 0.40mm	1
935 151 723 510-T4N	T&R 10 000units	ENIG(**)	0201 - 10nF – 2 pads – 0.8 x 0.6 mm x 0.40mm	1
935 152 723 510-F1N	6" film frame carrier	ENIG(**)	0201 - 10nF – 2 pads – 0.8 x 0.6 mm x 0.10mm	1
935 152 723 510-T3N	T&R 1 000units	ENIG(**)	0201 - 10nF – 2 pads – 0.8 x 0.6 mm x 0.10mm	1
935 152 723 510-T4N	T&R 10 000units	ENIG(**)	0201 - 10nF – 2 pads – 0.8 x 0.6 mm x 0.10mm	1

Table 4: Packing ordering information

(\*\*) ENIG : Min 0.1µm Au / 5µm Ni  
 (\*\*\*) Other film frame carrier are possible on request

## Test and Quality inspection

The Murata manufacturing center is certified:

- ISO-9001
- ISO-14001
- ISO-13485
- ISO-TS16949
- OHSAS-18001

Murata is RoHS compliant.

## Mounting conditions

---

The UBSC Capacitor is compatible with standard reflow technology.  
It is recommended to design mirror pads on the PCB.  
For further information, please see our mounting application note.

## Pad Metallization

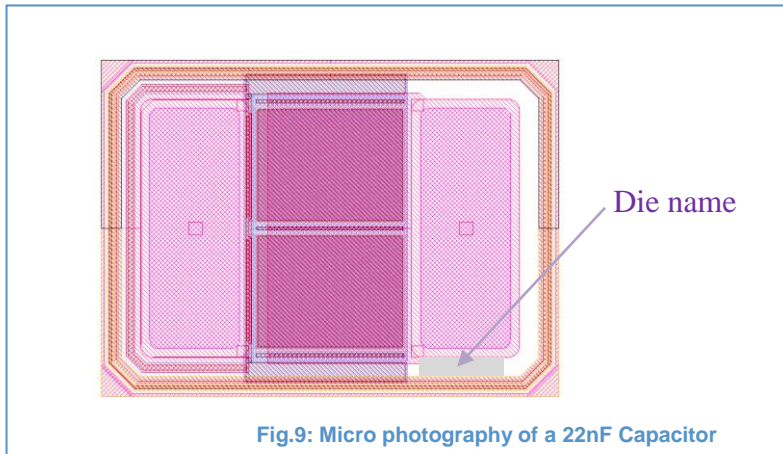
---

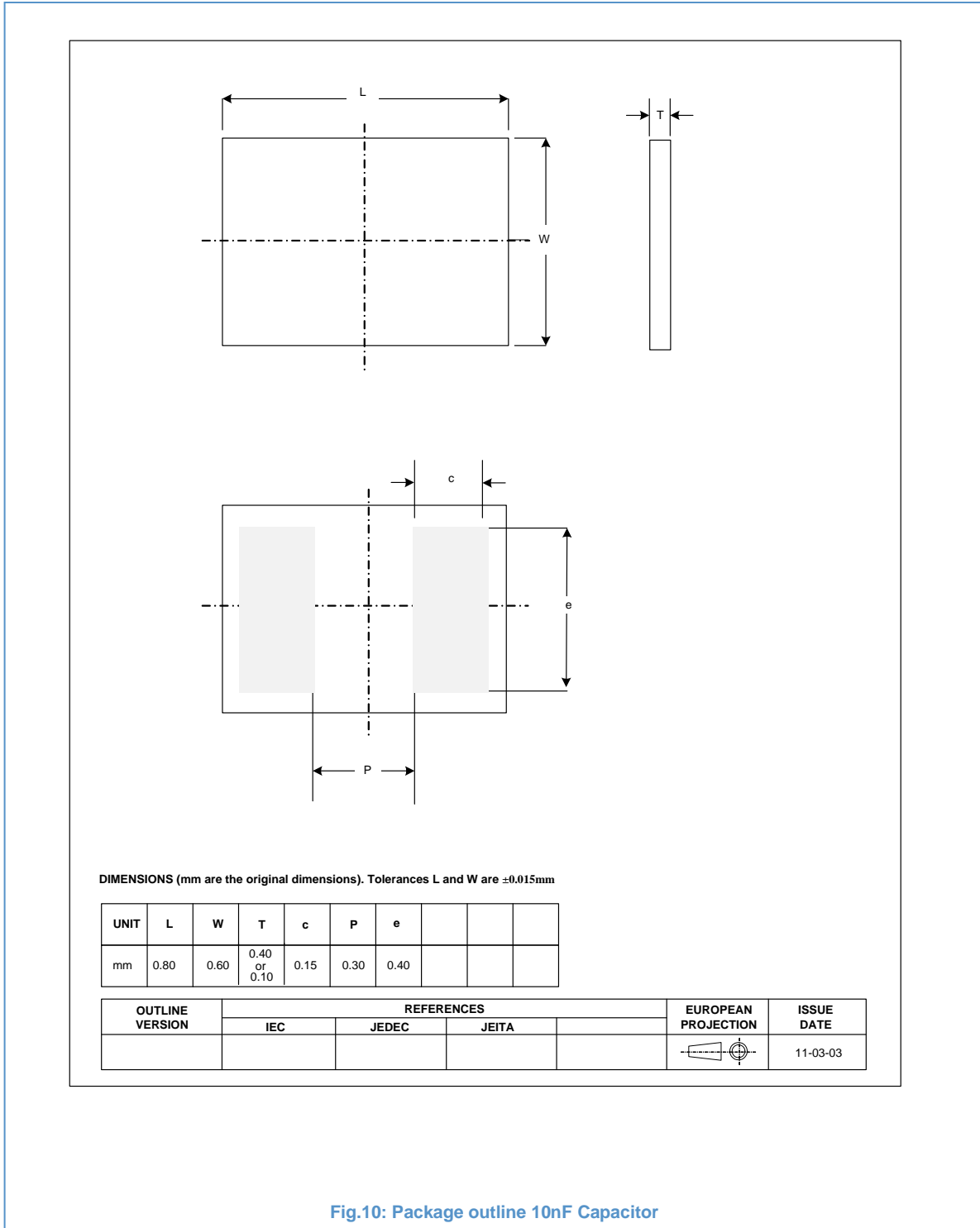
The UBSC Capacitor is delivered as standard with NiAu finishing [ENIG].  
Other Metallization, such as Copper, Thick Gold or Aluminum pads are possible on request.  
UBSC series is compatible with standard reflow technology.  
It is recommended to design mirror pads on the PCB.  
For further information, please see our mounting application note.

## Package outline

---

The UBSC Capacitor is delivered as a naked die, with opening for contacts.

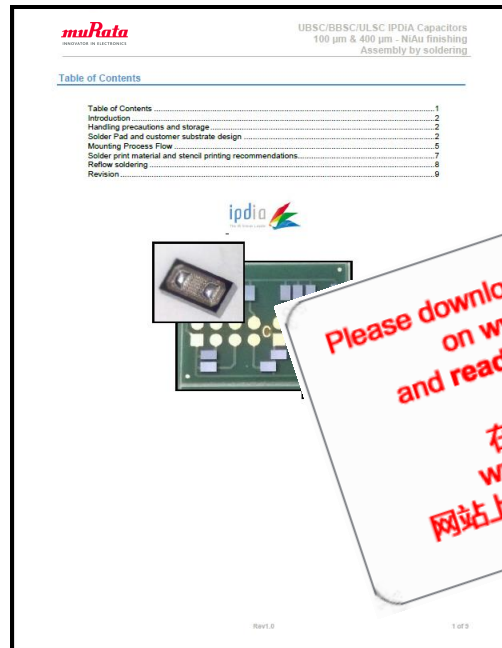




**Fig.10: Package outline 10nF Capacitor**

## Assembly consideration

The attachment techniques recommended by Murata for the UBSC/BBSC/ULSC capacitors silicon capacitors on the customers substrates are fully detailed in specific documents available on our website. **To assure the correct use and proper functioning of Murata capacitors please download the assembly instructions on [www.ipdia.com/assembly](http://www.ipdia.com/assembly) and read them carefully.**



For UBSC/BBSC/ULSC assembly instructions @ 100 & 400  $\mu\text{m}$ , please go to [www.ipdia.com/assembly](http://www.ipdia.com/assembly) and download the pdf file called “**Murata UBSC, BBSC, ULSC- 100&400 $\mu\text{m}$  - NiAu finishing - Assembly by Soldering**”.

## Packing format

### Tape and Reel format definition:

Tape Ref	Cavity dimensions			Carrier Tape width	Carrier Tape pitch	Reel size	Qty per reel
	Ao	Bo	Ko				
BD0050 x 0100	0.65 mm	1.14 mm	0.56mm	8 mm	4mm	7"	1 000

Table 5: Tape & Reel references

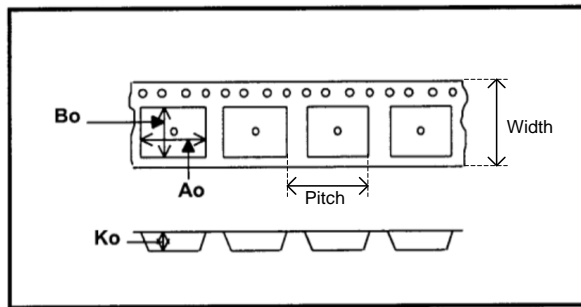


Fig. 12: Tape & Reel dimensions

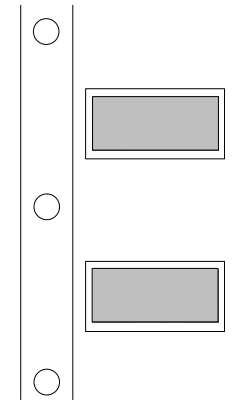


Fig. 13: Die orientation (flip) within the carrier (Pocket) related to tape and reel orientation

Tape Width	A Diameter	C	D (min)	N Hub	W1	W2 (max)
8mm	178 mm +/- 1.0	13.5 mm ± 0.5	20.2 mm	60 mm + 0.1 -0.0	93mm ± 0.5	11.5

Table 6 : Reel references used for tape width 8mm

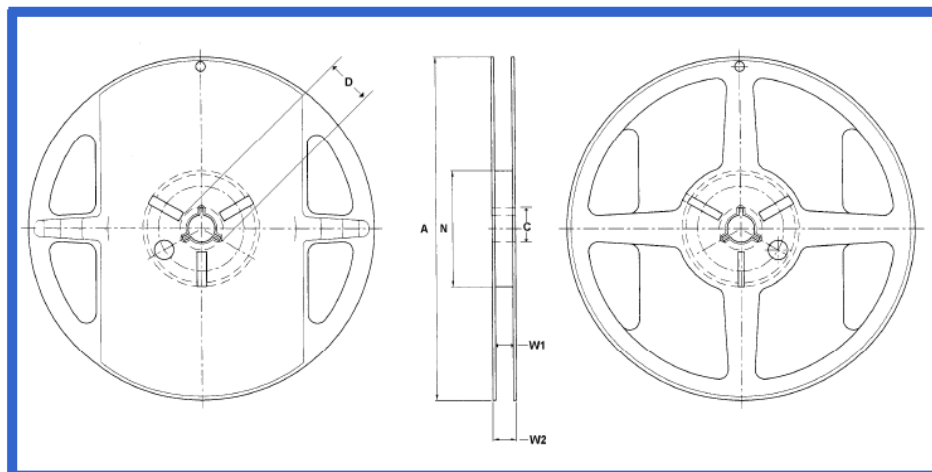


Fig. 14 : Reel references and dimensions used for tape width 8mm



**Film frame carrier format definition:** Ref: FF070 (Perfection products)

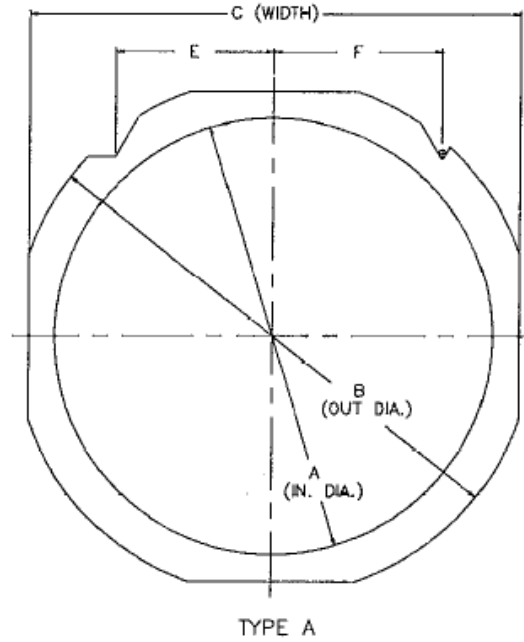


Fig.15: Dimension of film frame carrier

Wafer diameter (***)	Frame type	Inside diameter (A)	Outside diameter (B)	Width (C)	Thickness (D)	Pin location (E)	Pin location (F)	Frame style	Weight(lbs) (stainless)
6.0" (150mm)	Type A	7.639"	8.976"	8.346"	0.048	2.370"	2.500"	DTF-2-6-1	0.21

(\*\*\*) other size and type on request.

Table 7: Details of film frame carrier

## Definitions

<b>Data sheet status</b>	
Objective specification	This data sheet contains target or goal specifications for product development.
Preliminary specification	This data sheet contains preliminary data; supplementary data may be published later.
Product specification	This data sheet contains final product specifications.
<b>Limiting values</b>	
Limiting values given are in accordance with the Absolute Maximum Rating System (IEC 134). Stress above one or more of the limiting values may cause permanent damage to the device. These are stress ratings only and operation of the device at these or any other conditions above those given in the Characteristics sections of this specification is not implied. Exposure to limiting values for extended periods may affect device reliability.	
<b>Application information</b>	
Where application information is given, it is advisory and does not form part of the specification.	

## Revision history

Revision	Date	Description	Author
<b>Release 1.0</b>	<b>2015 February 18<sup>th</sup></b>	<b>Objective specification</b>	<b>OGA</b>
<b>Release 1.1</b>	<b>2015 June 18<sup>th</sup></b>	<b>Graphs updated</b>	<b>OGA</b>
<b>Release 1.2</b>	<b>2016 March 31<sup>th</sup></b>	<b>Typo update</b>	<b>OGA</b>
<b>Release 1.3</b>	<b>2016 Sept 19<sup>th</sup></b>	<b>Typo update</b>	<b>OGA</b>
<b>Release 1.4</b>	<b>2017 March 29<sup>th</sup></b>	<b>General update</b>	<b>OGA</b>
<b>Release 1.5</b>	<b>2017 June 15<sup>th</sup></b>	<b>Murata version</b>	<b>OGA</b>

## Life Support Applications

These products are not designed for use in life support appliances, devices, or systems where malfunction of these products can reasonably be expected to result in personal injury. Murata customers using or selling these products for use in such applications do so at their own risk and agree to fully indemnify Murata for any damages resulting from such improper use or sale.

Reproduction in whole or in part is prohibited without the prior written consent of the copyright owner. The information presented in this document does not form part of any quotation or contract, is believed to be accurate and reliable and may be changed without notice. No liability will be accepted by the publisher for any consequence of its use. Publication thereof does not convey nor imply any license under patent- or other industrial or intellectual property rights.