

RA2A1 Group

Evaluation Kit for RA2A1 Microcontroller Group
EK-RA2A1 v1
User's Manual

Renesas RA Family
RA2 Series

All information contained in these materials, including products and product specifications, represents information on the product at the time of publication and is subject to change by Renesas Electronics Corp. without notice. Please review the latest information published by Renesas Electronics Corp. through various means, including the Renesas Electronics Corp. website (<http://www.renesas.com>).

Notice

1. Descriptions of circuits, software and other related information in this document are provided only to illustrate the operation of semiconductor products and application examples. You are fully responsible for the incorporation or any other use of the circuits, software, and information in the design of your product or system. Renesas Electronics disclaims any and all liability for any losses and damages incurred by you or third parties arising from the use of these circuits, software, or information.
2. Renesas Electronics hereby expressly disclaims any warranties against and liability for infringement or any other claims involving patents, copyrights, or other intellectual property rights of third parties, by or arising from the use of Renesas Electronics products or technical information described in this document, including but not limited to, the product data, drawings, charts, programs, algorithms, and application examples.
3. No license, express, implied or otherwise, is granted hereby under any patents, copyrights or other intellectual property rights of Renesas Electronics or others.
4. You shall not alter, modify, copy, or reverse engineer any Renesas Electronics product, whether in whole or in part. Renesas Electronics disclaims any and all liability for any losses or damages incurred by you or third parties arising from such alteration, modification, copying or reverse engineering.
5. Renesas Electronics products are classified according to the following two quality grades: "Standard" and "High Quality". The intended applications for each Renesas Electronics product depends on the product's quality grade, as indicated below.
 - "Standard": Computers; office equipment; communications equipment; test and measurement equipment; audio and visual equipment; home electronic appliances; machine tools; personal electronic equipment; industrial robots; etc.
 - "High Quality": Transportation equipment (automobiles, trains, ships, etc.); traffic control (traffic lights); large-scale communication equipment; key financial terminal systems; safety control equipment; etc.Unless expressly designated as a high reliability product or a product for harsh environments in a Renesas Electronics data sheet or other Renesas Electronics document, Renesas Electronics products are not intended or authorized for use in products or systems that may pose a direct threat to human life or bodily injury (artificial life support devices or systems; surgical implantations; etc.), or may cause serious property damage (space system; undersea repeaters; nuclear power control systems; aircraft control systems; key plant systems; military equipment; etc.). Renesas Electronics disclaims any and all liability for any damages or losses incurred by you or any third parties arising from the use of any Renesas Electronics product that is inconsistent with any Renesas Electronics data sheet, user's manual or other Renesas Electronics document.
6. When using Renesas Electronics products, refer to the latest product information (data sheets, user's manuals, application notes, "General Notes for Handling and Using Semiconductor Devices" in the reliability handbook, etc.), and ensure that usage conditions are within the ranges specified by Renesas Electronics with respect to maximum ratings, operating power supply voltage range, heat dissipation characteristics, installation, etc. Renesas Electronics disclaims any and all liability for any malfunctions, failure or accident arising out of the use of Renesas Electronics products outside of such specified ranges.
7. Although Renesas Electronics endeavors to improve the quality and reliability of Renesas Electronics products, semiconductor products have specific characteristics, such as the occurrence of failure at a certain rate and malfunctions under certain use conditions. Unless designated as a high reliability product or a product for harsh environments in a Renesas Electronics data sheet or other Renesas Electronics document, Renesas Electronics products are not subject to radiation resistance design. You are responsible for implementing safety measures to guard against the possibility of bodily injury, injury or damage caused by fire, and/or danger to the public in the event of a failure or malfunction of Renesas Electronics products, such as safety design for hardware and software, including but not limited to redundancy, fire control and malfunction prevention, appropriate treatment for aging degradation or any other appropriate measures. Because the evaluation of microcomputer software alone is very difficult and impractical, you are responsible for evaluating the safety of the final products or systems manufactured by you.
8. Please contact a Renesas Electronics sales office for details as to environmental matters such as the environmental compatibility of each Renesas Electronics product. You are responsible for carefully and sufficiently investigating applicable laws and regulations that regulate the inclusion or use of controlled substances, including without limitation, the EU RoHS Directive, and using Renesas Electronics products in compliance with all these applicable laws and regulations. Renesas Electronics disclaims any and all liability for damages or losses occurring as a result of your noncompliance with applicable laws and regulations.
9. Renesas Electronics products and technologies shall not be used for or incorporated into any products or systems whose manufacture, use, or sale is prohibited under any applicable domestic or foreign laws or regulations. You shall comply with any applicable export control laws and regulations promulgated and administered by the governments of any countries asserting jurisdiction over the parties or transactions.
10. It is the responsibility of the buyer or distributor of Renesas Electronics products, or any other party who distributes, disposes of, or otherwise sells or transfers the product to a third party, to notify such third party in advance of the contents and conditions set forth in this document.
11. This document shall not be reprinted, reproduced or duplicated in any form, in whole or in part, without prior written consent of Renesas Electronics.
12. Please contact a Renesas Electronics sales office if you have any questions regarding the information contained in this document or Renesas Electronics products.

(Note1) "Renesas Electronics" as used in this document means Renesas Electronics Corporation and also includes its directly or indirectly controlled subsidiaries.

(Note2) "Renesas Electronics product(s)" means any product developed or manufactured by or for Renesas Electronics.

(Rev.4.0-1 November 2017)

Corporate Headquarters

TOYOSU FORESIA, 3-2-24 Toyosu,
Koto-ku, Tokyo 135-0061, Japan
www.renesas.com

Trademarks

Renesas and the Renesas logo are trademarks of Renesas Electronics Corporation. All trademarks and registered trademarks are the property of their respective owners.

Contact information

For further information on a product, technology, the most up-to-date version of a document, or your nearest sales office, please visit:
www.renesas.com/contact/.

EK-RA2A1 Disclaimer

By using this EK-RA2A1, the User accepts the following terms, which are in addition to, and control in the event of disagreement, with Renesas' General Terms and Conditions available at <https://www.renesas.com/en-us/legal/disclaimer.html>.

The EK-RA2A1 is not guaranteed to be error free, and the entire risk as to the results and performance of the EK-RA2A1 is assumed by the User. The EK-RA2A1 is provided by Renesas on an "as is" basis without warranty of any kind whether express or implied, including but not limited to the implied warranties of good workmanship, fitness for a particular purpose, title, merchantability, and non-infringement of intellectual property rights. Renesas expressly disclaims any implied warranty.

Renesas does not consider the EK-RA2A1 to be a finished product and therefore the EK-RA2A1 may not comply with some requirements applicable to finished products, including, but not limited to recycling, restricted substances and electromagnetic compatibility regulations. Refer to Certifications section, for information about certifications and compliance information for the EK-RA2A1. It is the kit User's responsibility to make sure the kit meets any local requirements applicable to their region.

Renesas or its affiliates shall in no event be liable for any loss of profit, loss of data, loss of contract, loss of business, damage to reputation or goodwill, any economic loss, any reprogramming or recall costs (whether the foregoing losses are direct or indirect) nor shall Renesas or its affiliates be liable for any other direct or indirect special, incidental or consequential damages arising out of or in relation to the use of this EK-RA2A1, even if Renesas or its affiliates have been advised of the possibility of such damages.

Renesas has used reasonable care in preparing the information included in this document, but Renesas does not warrant that such information is error free nor does Renesas guarantee an exact match for every application or parameter to part numbers designated by other vendors listed herein. The information provided in this document is intended solely to enable the use of Renesas products. No express or implied license to any intellectual property right is granted by this document or in connection with the sale of Renesas products. Renesas reserves the right to make changes to specifications and product descriptions at any time without notice. Renesas assumes no liability for any damages incurred by you resulting from errors in or omissions from the information included herein. Renesas cannot verify, and assumes no liability for, the accuracy of information available on another company's website.

Precautions

This Evaluation Kit is only intended for use in a laboratory environment under ambient temperature and humidity conditions. A safe separation distance should be used between this and any sensitive equipment. Its use outside the laboratory, classroom, study area, or similar such area invalidates conformity with the protection requirements of the Electromagnetic Compatibility Directive and could lead to prosecution.

The product generates, uses, and can radiate radio frequency energy and may cause harmful interference to radio communications. There is no guarantee that interference will not occur in a particular installation. If this equipment causes harmful interference to radio or television reception, which can be determined by turning the equipment off or on, you are encouraged to try to correct the interference by one or more of the following measures:

- Ensure attached cables do not lie across the equipment.
- Reorient the receiving antenna.
- Increase the distance between the equipment and the receiver.
- Connect the equipment into an outlet on a circuit different from that which the receiver is connected.
- Power down the equipment when not in use.
- Consult the dealer or an experienced radio/TV technician for help.

Note: It is recommended that wherever possible shielded interface cables are used.

The product is potentially susceptible to certain EMC phenomena. To mitigate against them it is recommended that the following measures be undertaken:

- The user is advised that mobile phones should not be used within 10 m of the product when in use.
- The user is advised to take ESD precautions when handling the equipment.

The Evaluation Kit does not represent an ideal reference design for an end product and does not fulfill the regulatory standards for an end product.

Renesas RA Microcontrollers

EK-RA2A1 v1
Contents

| | | |
|---------|---|----|
| 1. | Kit Overview | 3 |
| 1.1 | Assumptions and Advisory Notes..... | 6 |
| 2. | Kit Contents..... | 6 |
| 3. | Ordering Information..... | 6 |
| 4. | Hardware Details | 7 |
| 4.1 | Jumpers Settings..... | 7 |
| 4.1.1 | Copper Jumpers..... | 7 |
| 4.1.2 | Default Board Configuration..... | 7 |
| 5. | Hardware Layout | 9 |
| 5.1 | System Block Diagram | 9 |
| 5.2 | Power Requirements..... | 9 |
| 5.2.1 | Power Supply Options..... | 10 |
| 5.2.1.1 | Option 1: Debug USB (default) | 10 |
| 5.2.1.2 | Option 2: Test Points TP3 and TP4 | 10 |
| 5.2.1.3 | Option 3: Test Points TP1 and TP2 | 10 |
| 5.2.1.4 | Option 4: Pin Headers..... | 11 |
| 5.2.2 | Power-Up the Board..... | 11 |
| 5.2.3 | Measuring Current Consumption | 12 |
| 5.3 | Major Components | 13 |
| 5.4 | Connectivity and Settings..... | 13 |
| 5.4.1 | Device USB | 13 |
| 5.4.2 | Debug USB..... | 14 |
| 5.4.3 | SWD (JTAG)..... | 14 |
| 5.4.4 | LEDs..... | 15 |
| 5.4.5 | Switches | 16 |
| 5.4.6 | PMOD A | 17 |
| 5.4.7 | PMOD B | 17 |
| 5.4.8 | User Capacitive Touch Button..... | 18 |
| 5.5 | Pin Headers..... | 19 |
| 5.5.1 | Pin Header J1 | 20 |
| 5.5.2 | Pin Header J2..... | 20 |
| 5.5.3 | Pin Header J3..... | 21 |
| 5.5.4 | Pin Header J4..... | 22 |

| | | |
|---------|---|----|
| 5.6 | Additional Features..... | 22 |
| 5.6.1 | Analog Reference Voltages..... | 22 |
| 5.6.2 | On-Board Clock Crystals..... | 22 |
| 5.6.3 | User Potentiometer | 23 |
| 5.6.4 | Boot Configuration..... | 24 |
| 5.6.5 | Miscellaneous Signals..... | 24 |
| 5.6.5.1 | AVCC0/AVSS0 and AVCC1/AVSS1 | 24 |
| 5.6.5.2 | VCL..... | 25 |
| 5.6.5.3 | VCC_USB_LDO | 25 |
| 5.6.5.4 | VCC_USB | 25 |
| 5.6.5.5 | Signal P409/CAN | 25 |
| 5.6.5.6 | Signal P408/CMPIN1/CAN..... | 26 |
| 5.6.5.7 | Signal P102/SPI/ANSD1P..... | 26 |
| 6. | Certifications..... | 27 |
| 6.1 | EMC/EMI Standards..... | 27 |
| 6.2 | Material Selection, Waste, Recycling and Disposal Standards | 27 |
| 6.3 | Safety Standards | 27 |
| 7. | Design and Manufacturing Information | 28 |
| 8. | Website and Support | 28 |
| | Revision History..... | 29 |

1. Kit Overview

The EK-RA2A1 v1 enables developers to get started with initial firmware development.

- Renesas RA2A1 Microcontroller Group
 - R7FA2A1AB3CFM
 - 64-pin LQFP package
 - 48 MHz Arm® Cortex®-M23 core (Armv8-M architecture) with Arm MPU
 - 32 KB SRAM
 - 256 KB code flash memory
 - 8 KB data flash memory
- Connectivity
 - A Device USB connector for the Main MCU
 - S124 MCU based SEGGER J-Link® On-Board interface for debugging and programming of the RA2A1 MCU. A 10-pin JTAG/SWD interface is also provided for connecting optional external debuggers and programmers.
 - Two PMOD connectors, allowing use of appropriate PMOD compliant peripheral plug-in modules for rapid prototyping
 - Pin headers for access to power and signals for the Main MCU
- Multiple clock sources
 - Main MCU oscillator crystals, providing precision 12.000 MHz and 32,768 Hz external reference clocks
 - Additional low-precision clocks are available internal to the Main MCU
- MCU reset push-button switch
- MCU boot configuration jumper
- General purpose I/O ports
 - One jumper to allow measuring of Main MCU current
 - Copper jumpers on PCB bottom side for configuration and access to selected MCU signals
- Operating voltage
 - External 5V input through the Debug USB connector supplies the on-board power regulator, which provides 3.3V to power the board logic and interfaces. External 5V or 3.3V may be also supplied through alternate locations on the Evaluation Kit Board.
- A two-color board status LED indicating availability of regulated power and connection status of the J-Link interface
- A red User LED, controlled by the Main MCU firmware
- A User Push-Button switch, User Capacitive Touch Button sensor, and an optional User Potentiometer, all of which are controlled by the Main MCU firmware

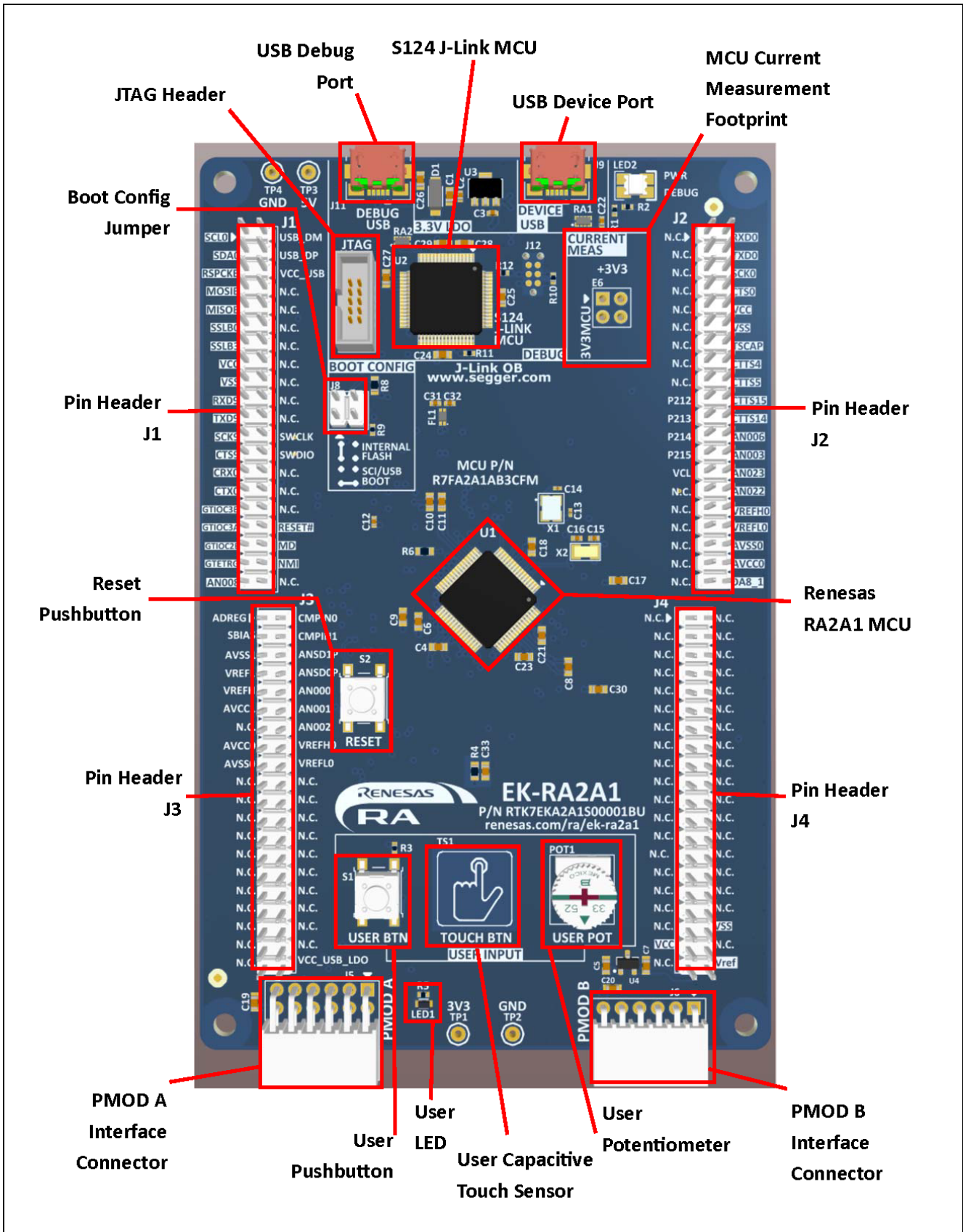

Figure 1. EK-RA2A1 v1 Top Side

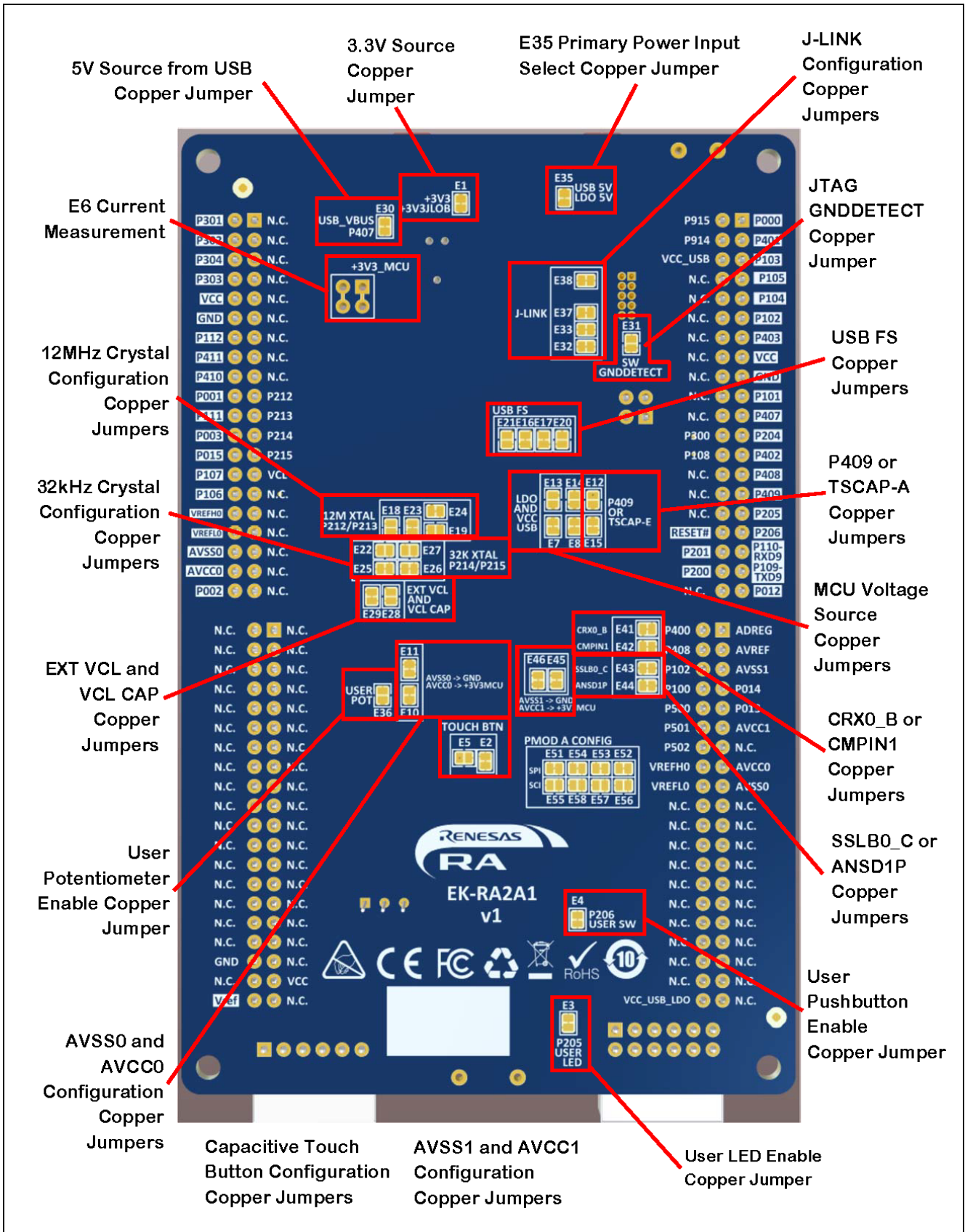

Figure 2. EK-RA2A1 v1 Bottom Side

1.1 Assumptions and Advisory Notes

1. It is assumed that the user has a basic understanding of microcontrollers and embedded systems hardware
2. It is recommended that the user refers to the EK-RA2A1 - Quick Start Guide to become acquainted with the kit and the Quick Start example the EK-RA2A1 comes preprogrammed with.
3. Flexible Software Package (FSP) and Integrated Development Environment (IDE) such as e² studio are required to develop embedded applications on EK-RA2A1. Instructions to download and install software are provided in the Quick Start Guide.
4. Additionally, the instructions to import example projects, build them and program the EK-RA2A1 are also provided in the Quick Start Guide.

2. Kit Contents

The following components are included in the kit:

1. One EK-RA2A1 board
2. One USB Type-A to USB Micro-B cable

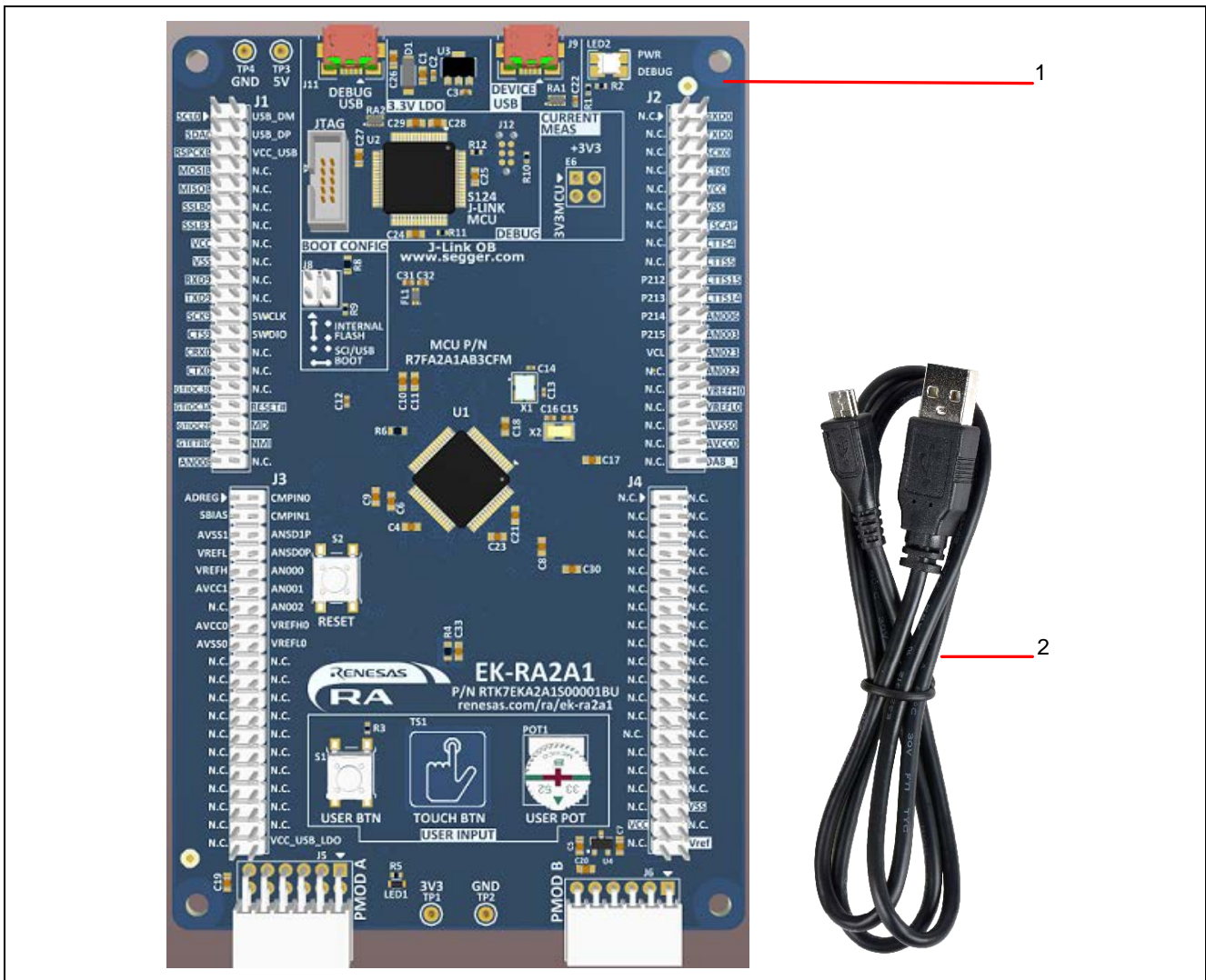

Figure 3. EK-RA2A1 v1 Kit Contents

3. Ordering Information

EK-RA2A1 Orderable Part Number: RTK7EKA2A1S00001BU

4. Hardware Details

4.1 Jumpers Settings

4.1.1 Copper Jumpers

Copper jumpers are of two types, designated **trace-cut** and **solder-bridge**.

A **trace-cut jumper** is provided with a narrow copper trace connecting its pads. The silk screen overlay printing around a trace-cut jumper is a solid box. To isolate the pads, cut the trace between pads adjacent to each pad, then remove the connecting copper foil either mechanically or with the assistance of heat. Once the etched copper trace is removed, the trace-cut jumper is turned into a solder-bridge jumper for any later changes.

A **solder-bridge jumper** is provided with two isolated pads that may be joined together by one of three methods:

- Solder may be applied to both pads to develop a bulge on each and the bulges joined by touching a soldering iron across the two pads.
- A small wire may be placed across the two pads and soldered in place.
- A SMT resistor, size 0805, 0603, or 0402, may be placed across the two pads and soldered in place. A zero-ohm resistor shorts the pads together.

The silk screen overlay printing around a solder-bridge jumper is a box with a gap in the lines adjacent to the isolation region between the pads.

For any copper jumper, the connection is considered **closed** if there is an electrical connection between the pads (default for trace-cut jumpers.) The connection is considered **open** if there is no electrical connection between the pads (default for the solder-bridge jumpers.)

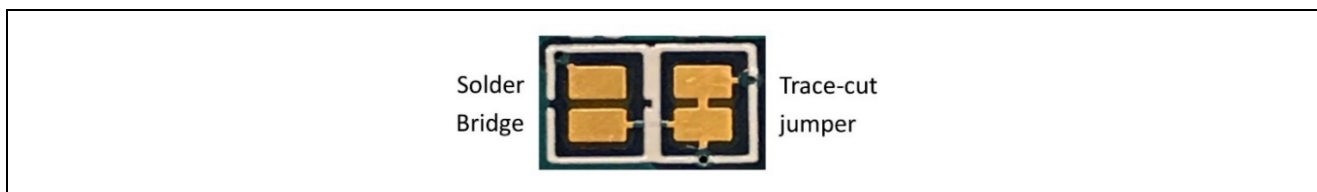

Figure 4. Copper Jumpers

4.1.2 Default Board Configuration

The following table describes the default settings for each jumper on the EK-RA2A1. This includes traditional pin jumpers (Jx designation) and copper jumpers (Ex designation.)

The Circuit Group for each jumper is the designation found in the board schematic. See section 7, Design and Manufacturing Information. Functional details for many of the listed jumpers may be found in section 5.4, Connectivity and Settings, and section 5.6, Additional Features.

Table 1. Default Jumper Settings

| Location | Circuit Group | Default Open/Closed | Function |
|----------|-----------------------|---------------------|---|
| J8 | MCU Mode Config | Shunt on pins 1-2 | Sets the MCU Mode to boot from Internal Flash |
| E18 | 12M Crystal | Open | Connects P213/XTAL on MCU to J2-21 |
| E19 | | Open | Connects P212/EXTAL on MCU to J2-19 |
| E23 | | Closed | Connects 12.000 MHz Crystal to MCU |
| E24 | | Closed | Connects 12.000 MHz Crystal to MCU |
| E1 | 3.3V Linear Regulator | Closed | Alternate 3.3V source (+3V3JLOB) |
| E22 | 32K Crystal | Open | Connects P215/XCIN on MCU to J2-25 |
| E25 | | Closed | Connects 32.768 kHz Crystal to MCU |
| E26 | | Closed | Connects 32.768 kHz Crystal to MCU |
| E27 | | Open | Connects P214/XCOUT on MCU to J2-23 |
| E10 | AVCC0-> +3V3MCU | Closed | Connects +3V3MCU to AVCC0 |
| E11 | AVSS0->GND | Closed | Connects Ground to AVSS1 |

| Location | Circuit Group | Default Open/Closed | Function |
|----------|-------------------------|---------------------|--|
| E2 | Capacitive Touch Button | Closed | Enable/Disable Capacitive Touch Button (connects P001 on MCU to Capacitive Touch Button) |
| E5 | | Open | Connects P001 on MCU to J2-20 |
| E28 | EXT VCL and VCL CAP | Open | Connects VCL to MCU |
| E29 | | Closed | Connects MCU pin 15 (VCL) to capacitor |
| E32 | J-Link | Closed | Connects the S124 MCU to the J-Link signal JLED |
| E33 | | Closed | Connects the S124 MCU to the J-Link signal RESET# |
| E37 | | Closed | Connects the S124 MCU to the J-Link signal P100/SWDIO |
| E38 | | Closed | Connects the S124 MCU to the J-Link signal P300/SWCLK |
| E35 | J-Link OB USB | Closed | Connects the J-Link OB USB 5V input to the primary 5V->3.3V voltage regulator |
| E31 | JTAG Connector | Open | JTAG Ground Detect. Connects the JTAG connector pin 9 to Ground. |
| E13 | LDO and VCC USB | Open | Connects VCC_USB_LDO to MCU pin 41 |
| E14 | | Open | Connects VCC_USB_LDO to MCU pin 40 |
| E7 | | Closed | Connects +3V3MCU to MCU pin 41 |
| E8 | | Closed | Connects +3V3MCU to MCU pin 40 |
| E12 | P409/CAN or TSCAP-E | Open | Connects P409/CAN on MCU to J1-29 |
| E30 | USB Device Interface | Closed | Connects the Device USB 5V input to the MCU |
| E16 | USB FS | Closed | Connects P915/USB_DM on MCU to signal USB_N |
| E17 | | Closed | Connects P914/USB_DP on MCU to signal USB_P |
| E20 | | Open | Connects P914/USB_DP on MCU to signal USBPH_P |
| E21 | | Open | Connects P915/USB_DM on MCU to signal USBPH_N |
| E3 | User LED | Closed | Enable/Disable User LED |
| E36 | User Potentiometer | Open | Enable/Disable User Potentiometer |
| E4 | User Push-Button | Closed | Enable/Disable User Push-Button switch |
| E6 | +3V3_MCU | Closed | Dual Jumper. Pins 1 and 3 connect +3V3 to +3V3MCU. Pins 2 and 4 are not used. |
| E41 | CRX0_B (P408) -> J1 | Closed | Connects P408 on MCU to J1-27 |
| E42 | CMPIN1 (P408) -> J3 | Closed | Connects P408 on MCU to J3-4 |
| E43 | SSLB0_C (P102) -> J1 | Closed | Connects P102 on MCU to J1-11 |
| E44 | ANSD1P (P102) -> J3 | Closed | Connects P102 on MCU to J3-6 |
| E45 | AVCC1 -> +3V3MCU | Closed | Connects +3V3MCU to AVCC1 |
| E46 | AVSS1 -> GND | Closed | Connects AVSS1 to Ground |

5. Hardware Layout

5.1 System Block Diagram

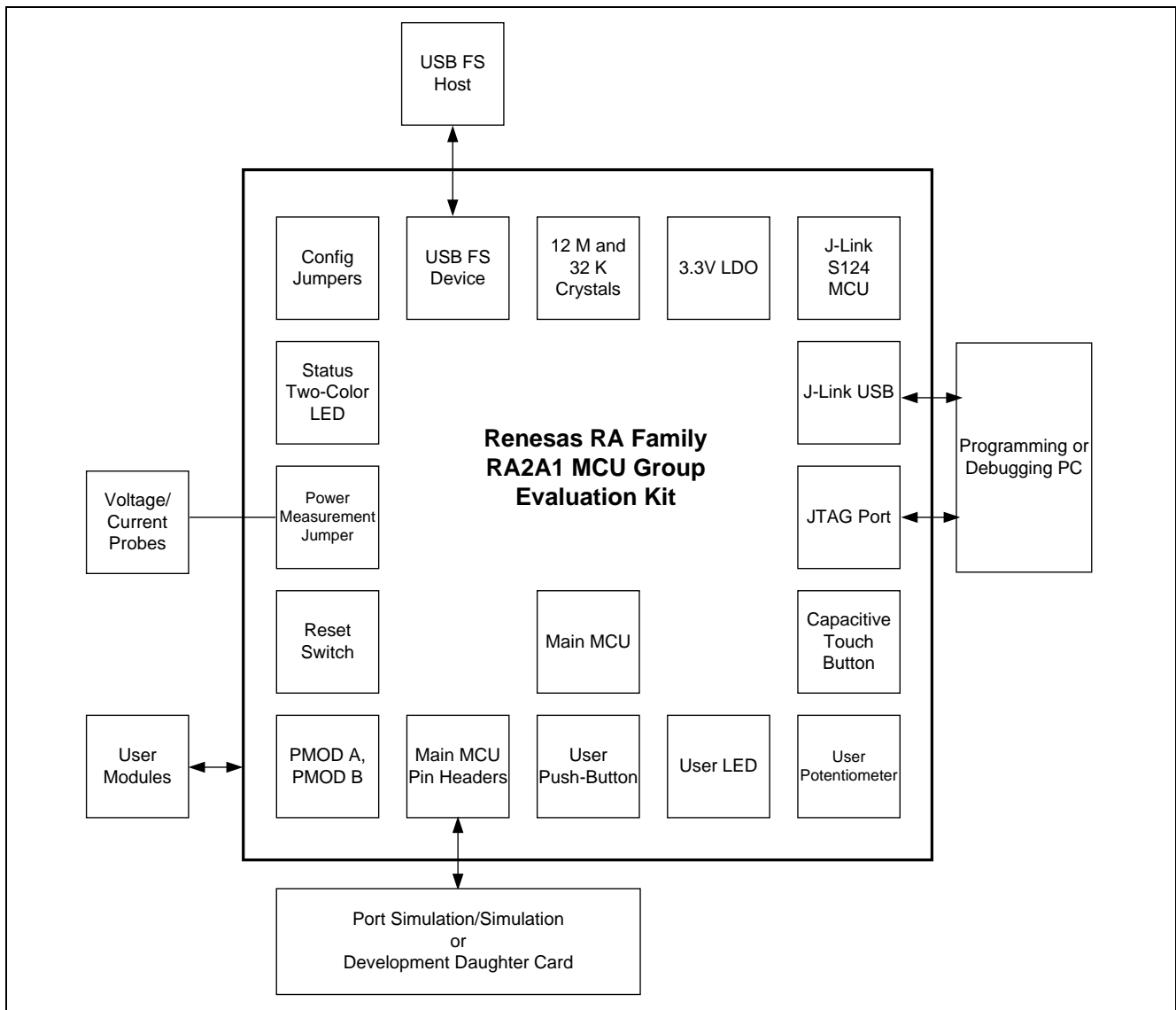

Figure 5. EK-RA2A1 Block Diagram

5.2 Power Requirements

The EK-RA2A1 is designed for 3.3V operation. This also means that 5V PMOD devices cannot be used together with the EK-RA2A1 unless they are powered separately.

The total current available from the LDO regulator for all connected circuits is 600 mA or less, depending on the 5V power source used.

5.2.1 Power Supply Options

EK-RA2A1 board can be powered in several different ways as described in this section.

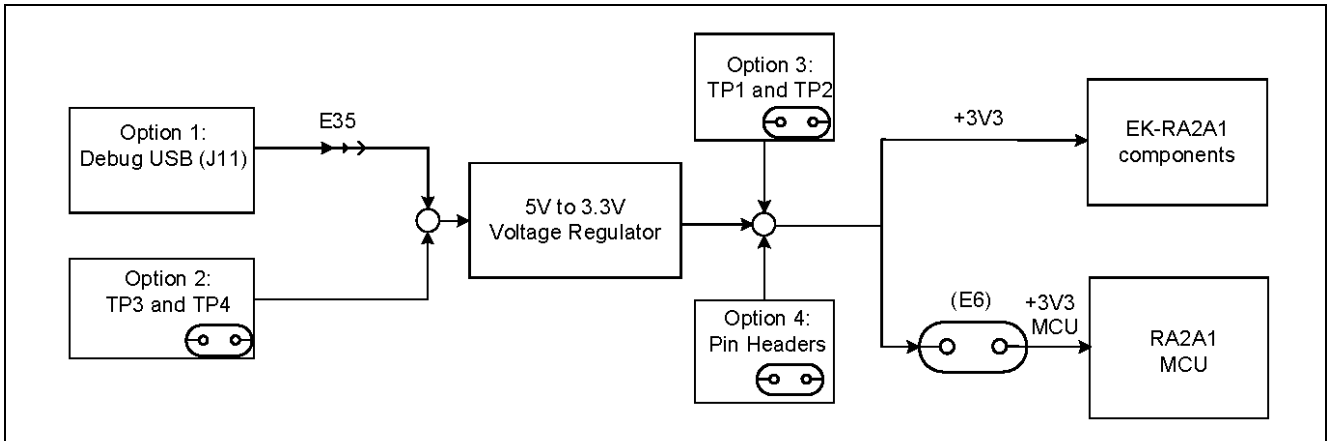

Figure 6. Power Supply Options

5.2.1.1 Option 1: Debug USB (default)

The default power source is 5V, supplied from an external USB host to the USB Debug connector labelled **DEBUG USB** on the top surface of the board. A low drop-out regulator (LDO) is used to convert the 5V signal to 3.3V, which then is used to power the MCU and any connected devices.

Copper jumper E35 selects the source for the primary power input to the LDO regulator. By default, this jumper is configured to provide power through the Debug USB connector. Copper jumper E35 is closed for this configuration.



5.2.1.2 Option 2: Test Points TP3 and TP4

EK-RA2A1 board can also be powered by installing a 5V power source across TP3 (positive input) and TP4 (negative input). Copper jumper E35 must be opened to enable powering the board using these test points.

! The on-board Low Dropout Regulator (see section 5.3 Major Components) has an input voltage range of +3.3V to +5.5V, and a built-in current limit of 600 mA. Make sure any external power source connected to TP3 and TP4 meets these requirements.

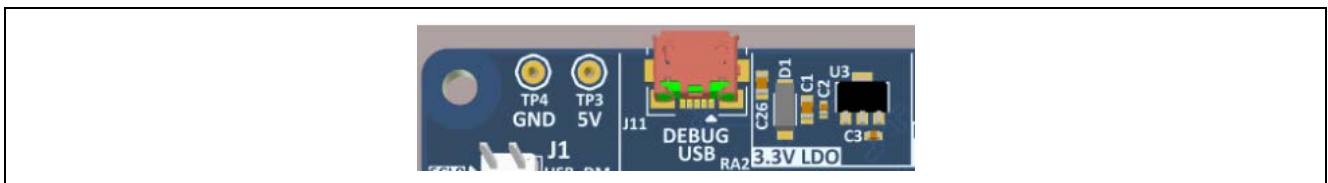

Figure 7. USB Debug Connector (J11), TP3, and TP4 on the Evaluation Kit Board

5.2.1.3 Option 3: Test Points TP1 and TP2

EK-RA2A1 board can also be powered by installing a 3.3V source across TP1 (positive input) and TP2 (negative input). Copper jumper E35 must be open to enable powering the board using these test points.

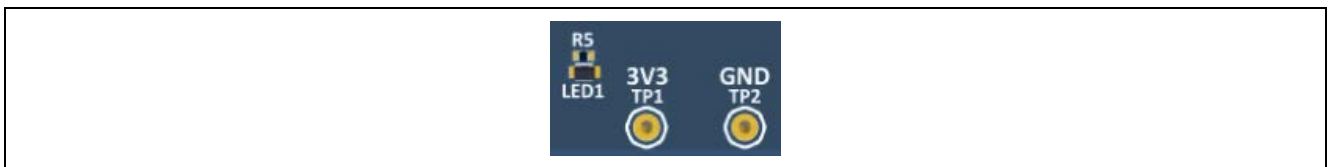

Figure 8. TP1, TP2, and LED1 on the Evaluation Kit Board

! These test points supply voltage directly to the RA2A1 MCU, the S124 J-Link MCU, and other on-board circuitry. Use caution to ensure that any voltage connected in this manner meets the power requirements for the active features. Power sources that are outside of the published operating range for the active devices may cause degraded performance or damage the board.

5.2.1.4 Option 4: Pin Headers

EK-RA2A1 board can also be powered through the following pin-headers.

- J1 (pin J1-15 for +3.3V, pin J1-17 for Return)
- J2 (pin J2-10 for +3.3V, pin J2-12 for Return)
- J4 (pin J4-37 for +3.3V, pin J4-36 for Return)

Copper jumper E35 must be open for any of these configurations.



The pin headers supply voltage directly to the RA2A1 MCU, the S124 J-Link MCU, and the other on-board circuitry. Use caution to ensure that any voltage connected in this manner meets the power requirements for the active features. Power sources that are outside of the published operating range for the active devices may cause degraded performance or damage the board.

See section 5.5, Pin Headers for more information on the Pin Headers.

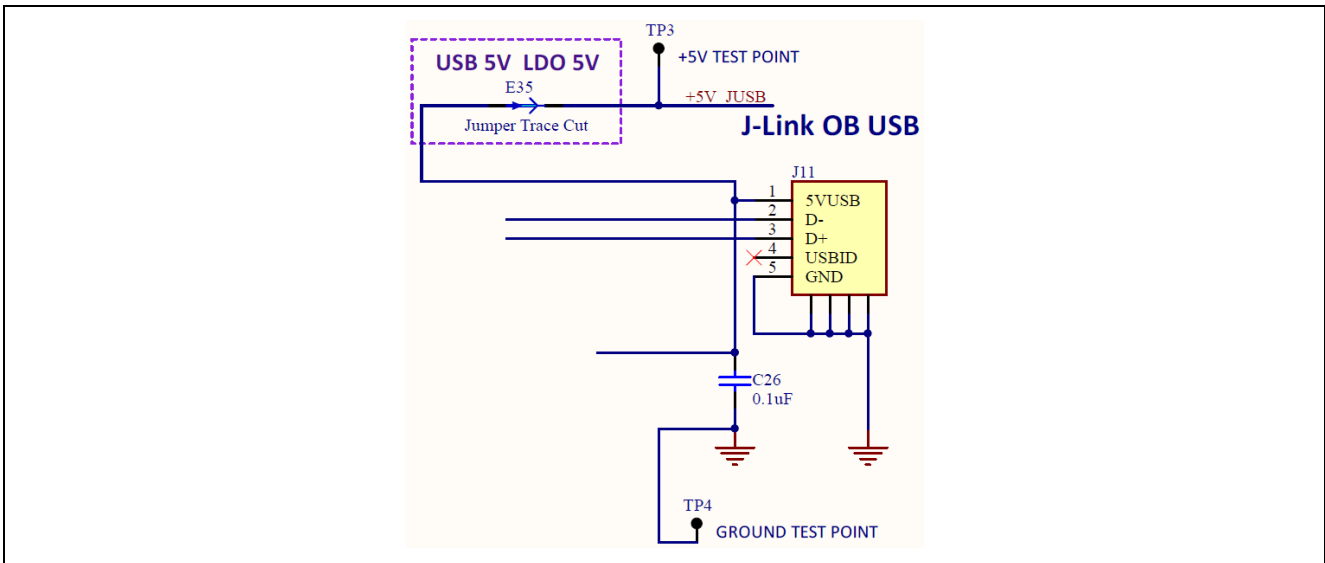

Figure 9. 5V Power Input Circuit

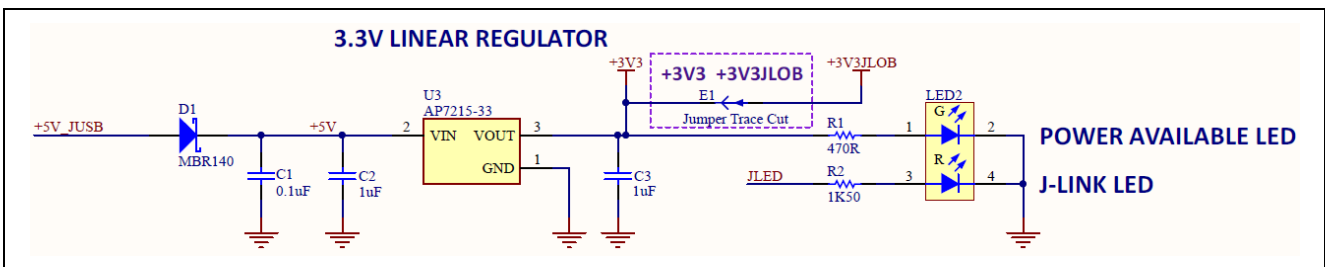

Figure 10. 3.3V Power Regulator Circuit

5.2.2 Power-Up the Board

When powered, the green LED to the right of the DEVICE USB connector (LED2) lights up.

The red LED in the same LED package functions as a status indicator for the J-Link On-Board debug interface on the board. If both LEDs in the LED2 package are lit, LED2 appears orange.

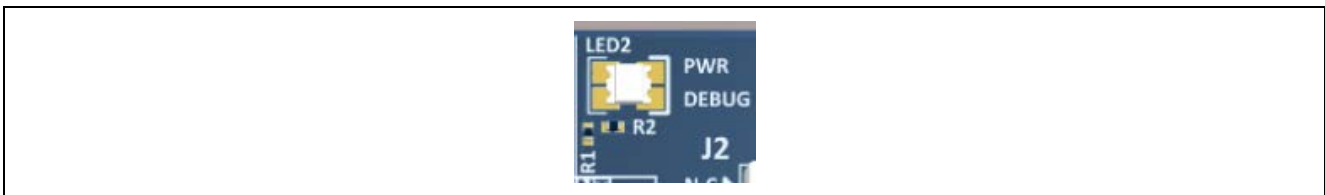

Figure 11. LED2 on the Evaluation Kit Board (Top Side)

5.2.3 Measuring Current Consumption

Pads 1 and 3 of copper jumper E6, which is a trace-cut jumper, allow measurement of +3V3 MCU supply current. Trace is connected by default and should be cut to enable power measurement. Care must be taken when cutting the trace to not cause damage to PCB layers below the trace.

The actual current consumed by the RA2A1 MCU is dependent on many factors, including ambient temperature, internal clock speed, input voltage level, and device activity. The actual current consumed by the MCU can vary from less than 1 mA to nearly 40 mA. Refer to the *RA2A1 Microcontroller Group User's Manual* for more information on the electrical characteristics of the MCU.

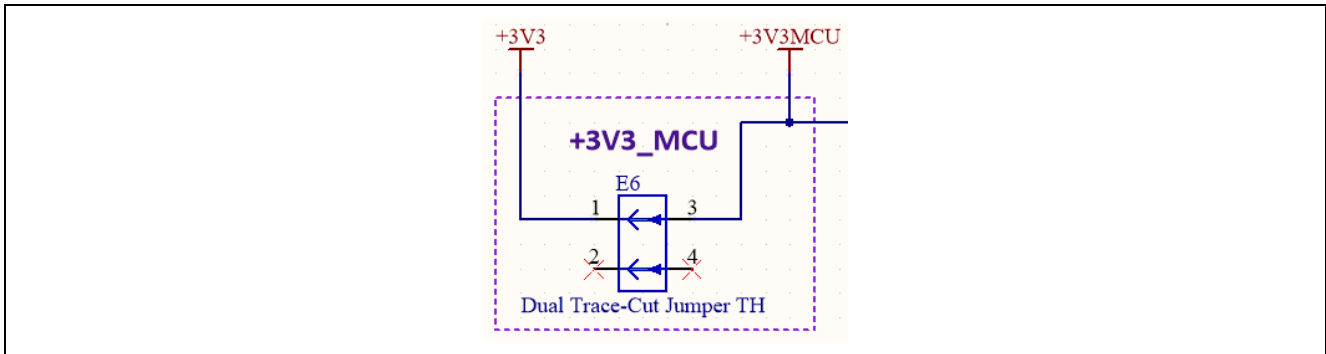

Figure 12. MCU Current Measurement Circuit

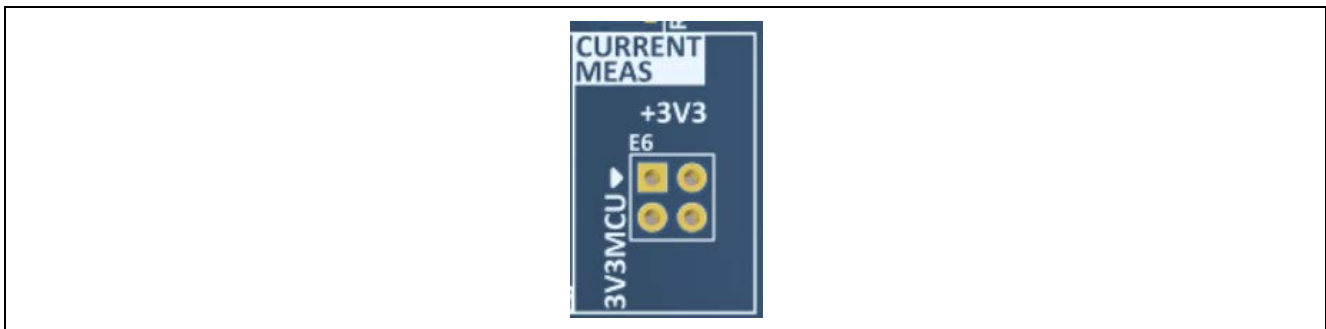

Figure 13. E6 on Evaluation Kit Board (Top Side)



Figure 14. E6 on Evaluation Kit Board (Bottom Side)

Once the shorting traces have been removed, there are several options to measure current:

- Pins can be installed that allow connection of a precision multi-meter or bench meter, or leaded current shunt to allow oscilloscope or data logger connection. When not measuring current, this allows easily installed and removed shunts to be used to short the jumper terminals.
- Another option is to install current sense resistors between pads 1 and 3 for +3V3MCU. Precision non-inductive film or foil resistors are recommended for use in this application, and the value of each resistor should be carefully considered.

For example, if the expected current requirement for the +3V3 MCU supply voltage is 10 mA, and the user would expect to measure a 10 mV drop across the current measurement resistor, then a 1.0-ohm resistor should be selected and installed. The actual value selected should be based on the operating conditions of the MCU for the specific user application and the sensitivity of the measurement equipment used.

5.3 Major Components

- Main MCU
 - RA2A1 MCU, part number R7FA2A1AB3CFM (U1)
 - Main MCU
- J-Link MCU
 - S124 MCU, part number R7FS124773A01CFM#AA0 (U2)
 - J-Link MCU
- USB Connectors
 - FCI, part number 10118192-0001LF (J9, J11)
 - Micro USB 2.0 Female connector
 - Primary communication with Main MCU and J-Link MCU
- Push-Buttons
 - C&K, part number PTS645SM43SMTR92 LFS (S1, S2)
 - Momentary push-button switch
 - Used for system reset and user defined functions
- LDO Regulator
 - Diodes Inc., part number AP7215-33YG-13 (U3)
 - Low-drop out linear regulator
 - Generates system 3.3V from J-Link USB 5V input
- PMOD A Connector
 - Samtec, part number SSW-106-02-F-D-RA (J5)
 - 12-pin right angle connector for PMOD A
- PMOD B Connector
 - Samtec, part number SSW-106-02-FM-S-RA (J6)
 - 6-pin right angle connector for PMOD B
- Pin Headers
 - Sullins, part number PRPC020DAAN-RC (J1, J2, J3, J4)
 - 40 position pin header, 0.1" pitch
 - Provides signal breakout and access for Main MCU signals
- System LED
 - Dialight, part number 598-8610-207F (LED2)
 - Dual color red/green LED
 - System status indicator for power and J-Link status
- User LED
 - Lite-On, part number LTST-C191KRKT (LED1)
 - User defined
 - Single color red LED as needed for user environment
- User Potentiometer
 - Bourns, part number 3352T-1-1-3LF (POT1)
 - User defined
 - Provides variable resistance as needed for user environment
 - Not populated by default

5.4 Connectivity and Settings

Throughout this section, feature configuration using copper jumpers is described. See section 4.1.1, Copper Jumpers for information on using copper jumpers.

5.4.1 Device USB

The DEVICE USB Micro-B connection jack connects the Main MCU to an external USB Host, FS capable, allowing communications for testing and use of the Main MCU firmware. Power for the board cannot be received from this connector. The DEVICE USB interface can detect the presence of power from the USB Host PC. USB Host power received at the DEVICE USB interface is not connected to the 5V power bus.

Table 2. DEVICE USB connector (J9)

| USB device connector | | EK-RA2A1 |
|----------------------|--|--------------------------------------|
| Pin | Description | Signal/Bus |
| 1 | +5VDC, connected to a sense voltage 2/3 divider to allow Main MCU sensing of Host presence | +5VUSB P407/USB_VBUS = 2/3(5VUSB) |
| 2 | Data- | P915/USB_DM |
| 3 | Data+ | P914/USB_DP |
| 4 | USB ID, jack internal switch, cable inserted | N.C. |
| 5 | Ground | GND |

Connections in Table 2 are based on the condition of copper jumpers E16, E17, E20, E21, and E30 matching their as-manufactured status. As-manufactured, E16 and E17 are closed, E20 and E21 are open, and E30 is closed.

Alternatively, the Device USB signals to the Main MCU may be connected to MCU Pin Header J1. To enable this configuration, copper jumpers E16 and E17 should be open, and E20 and E21 should be closed.



5.4.2 Debug USB

The DEBUG USB Micro-B connection jack connects the S124 J-Link MCU to an external USB Host, FS capable, allowing re-programming and debugging of the Main MCU firmware. Power for the board may be received from this connector.



The J-Link OB interface is multiplexed with the JTAG interface, and can collectively be referred to as the Programming Interface. While the J-Link OB interface and the JTAG interface do not conflict, the J-Link OB signals may be isolated from the programming interface by changing the associated copper jumpers.

J-Link Disconnect Copper Jumpers E32, E33, E37, and E38 connect the J-Link signals to the MCU programming interface. To isolate the J-Link signals from the JTAG interface, the copper jumpers must be open. To allow use of the J-Link interface, each copper jumper must be closed.

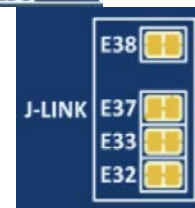

J-Link MCU Power Copper Jumper, E1, connects the main +3.3V power to the J-Link +3.3V power. The default condition for E1 is closed, which connects the J-Link MCU power to the main +3.3V power. If J-Link signals are disconnected, the power to the J-Link MCU should also be removed by changing E1 to open.



Table 3. DEBUG USB Connector (J11)

| DEBUG USB Connector | | EK-RA2A1 |
|---------------------|--|-------------------|
| Pin | Description | Signal/Bus |
| 1 | +5VDC | +5V_JUSB |
| 2 | Data- | U2 USB_DM (U2-18) |
| 3 | Data+ | U2 USB_DP (U2-19) |
| 4 | USB ID, jack internal switch, cable inserted | N.C. |
| 5 | Ground | GND |

5.4.3 SWD (JTAG)

A 10-pin Cortex Debug Connector is provided at J10.

Note: The RA2A1 MCU does not have JTAG support, only SWD.

Table 4. SWD Connector (J10)

| JTAG Connector | | EK-RA2A1 |
|----------------|--------------|-----------------------|
| Pin | SWD pin name | Signal/Bus |
| 1 | VTref | +3V3 |
| 2 | SWDIO | U1 P108/SWDIO (U1-33) |
| 3 | GND | GND |

| JTAG Connector | | EK-RA2A1 |
|----------------|--------------|------------------------------------|
| Pin | SWD pin name | Signal/Bus |
| 4 | SWCLK | U1 P300/SWCLK (U1-32) |
| 5 | GND | GND |
| 6 | N.C. | N.C. |
| 7 | N.C. | N.C. |
| 8 | N.C. | N.C. |
| 9 | GNDDetect | N.C. (short E31 to connect to GND) |
| 10 | nSRST | U1 RESET# (U1-25) |

The Cortex® Debug Connector is fully described in the *Arm® CoreSight™ Architecture Specification*.

The J-Link MCU Power copper jumper and J-Link Disconnects copper jumpers may be open for proper operation of the SWD interface to prevent interactions with the J-Link MCU. See section 5.4.1, Device USB for details.

If a SWD (JTAG) adapter is in use that properly interprets the Arm® Cortex® 10-pin Debug connector assignment of pin 9 to GND, SWD GNDDetect copper jumper E31 should be closed. If the SWD adapter used is one of several that may be confused or damaged by the presence of GND at pin 9, E31 should be open (as shipped).



The J-Link OB interface is multiplexed with the SWD interface, and can collectively be referred to as the Programming Interface. While the J-Link OB interface and the SWD interface do not conflict, the J-Link OB signals may be isolated from the programming interface by changing the copper jumpers as described in section 5.4.2, Debug USB.

5.4.4 LEDs

Two LEDs are provided on the EK-RA2A1 board. U1 is the Main MCU, and directly controls LED1. See Figure 8 for LED1 location and Figure 15 for the LED1 circuit. U2 is the J-Link MCU, and controls the red LED in LED2. See Figure 11 for LED2 location and Figure 10 for LED2 circuit.

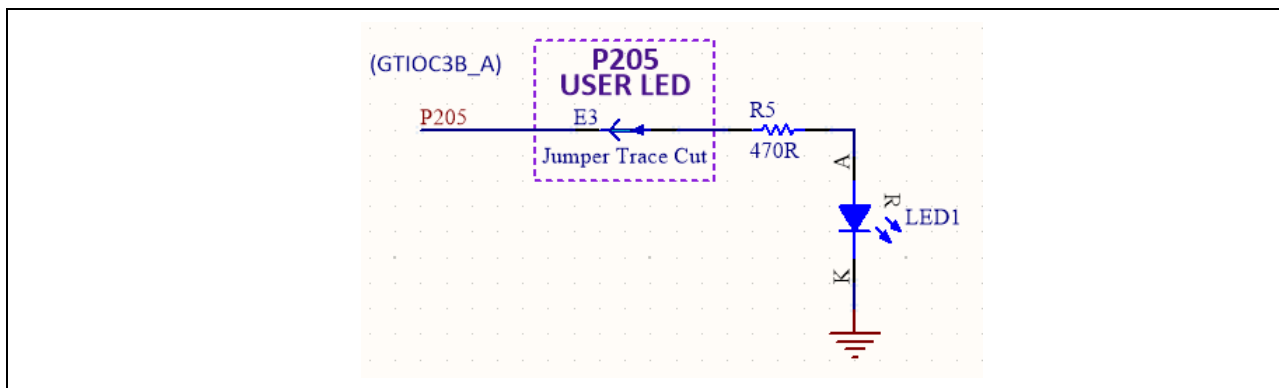

Figure 15. LED1 Control Circuit

The behavior of the LEDs is described in the following table.

Table 5. LED Functions

| Designator | Color | Function | MCU control port | MCU pin |
|------------|-------|----------------------|------------------|---------|
| LED1 | Red | User LED | U1 P205 | U1-23 |
| LED2 | Red | J-Link Indicator | JLED (U2 P103) | U2-45 |
| LED2 | Green | 3.3V Power Available | +3V3 | N.A. |

To disconnect the User LED from the MCU signal P205, copper jumper E3 must be open.



5.4.5 Switches

Two miniatures, momentary, mechanical push-button type SMT switches are mounted on the PCB. Pressing the RESET Switch generates a reset signal to restart the Main MCU. To disconnect the User Switch from the MCU signal P206/IRQ6_A, copper jumper E4 must be open.



Note: The correct port number for User SW (E4) is P206 as shown in the following schematic diagram. The board photograph (v1.2) showing P105 for the User SW (E4) (snippet shown to the right) is incorrect and should be P206 instead.

Table 6. Switches on the Evaluation Kit Board

| Designator | Function | MCU Control Port | MCU Pin |
|------------|------------------|------------------|---------|
| S1 | User Switch | U1 P206/IRQ6_A | U1-22 |
| S2 | MCU Reset Switch | RESET# | U1-25 |

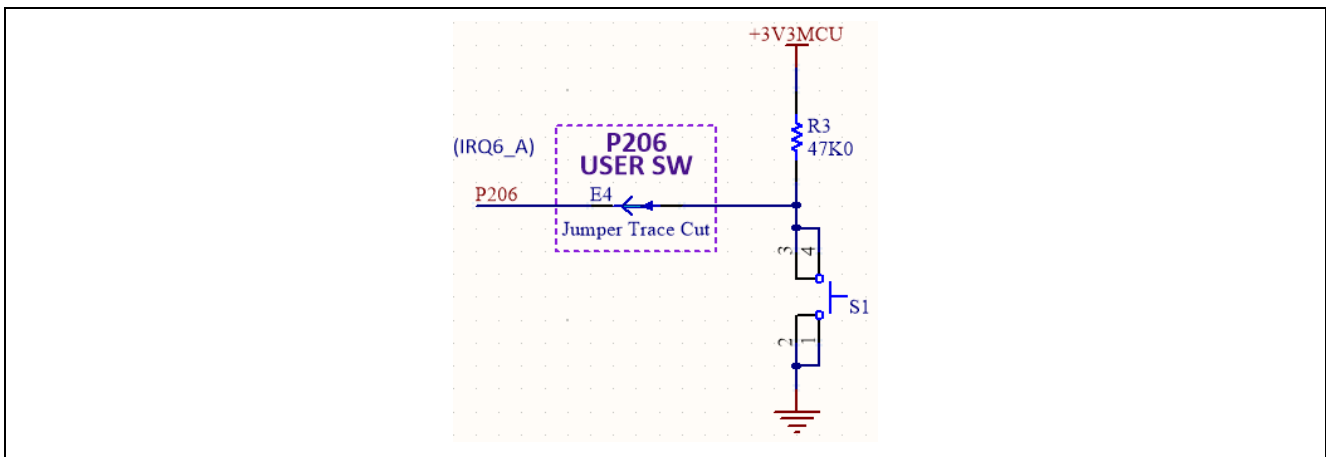

Figure 16. User Switch Circuit



Figure 17. User Switch (S1)

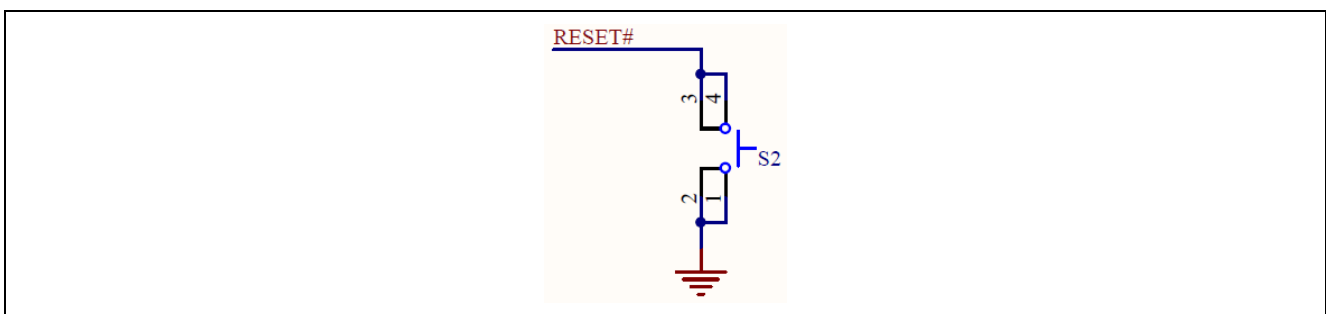

Figure 18. Reset Switch Circuit

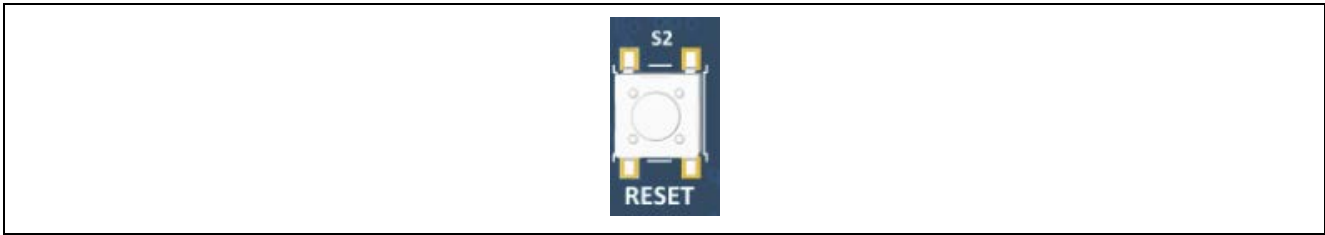

Figure 19. Reset Switch (S2) on Board

5.4.6 PMOD A

A 12-pin PMOD type 2A connector is provided at PMOD A. The interface is powered for 3.3V modules only. The Main MCU acts as the SPI master, and the connected module acts as an SPI slave device. This interface may additionally be re-configured in firmware as several other PMOD types.

Signals on PMOD A are shared with the Main MCU pin header J2. Care must be taken to ensure that shared signals are not used concurrently.



Table 7. PMOD A Connector (J5)

| PMOD A Connector | | EK-RA2A1 |
|------------------|--------------------------|---------------------------|
| Pin | Description | Signal/Bus |
| 1 | SS (low to select slave) | U1 P112, SSLA0_B (U1-36) |
| 2 | MOSI | U1 P303, MOSIA_B (U1-29) |
| 3 | MISO | U1 P304, MISOA_B (U1-28) |
| 4 | SCK | U1 P111, RSPCKA_B (U1-35) |
| 5 | GND | GND |
| 6 | VCC | +3V3 |
| 7 | INT (slave to master) | U1 P301, IRQ5_A (U1-31) |
| 8 | RESET (master to slave) | U1 P015, GPIO (U1-52) |
| 9 | Not Specified | U1 P107, GPIO (U1-41) |
| 10 | Not Specified | U1 P106, GPIO (U1-42) |
| 11 | GND | GND |
| 12 | VCC | +3V3 |

Limits of the 3.3V regulator on the PCB, and limits of the power source supplying that regulator (especially for USB Host devices), including the to-be-connected PMOD device, must be considered prior to connecting a module to a PMOD connector.

5.4.7 PMOD B

A 6-pin PMOD type 4 connector is provided at PMOD B. The interface is powered for 3.3V modules only. The Main MCU acts as the UART DCE, and the connected module acts as the UART DTE. This interface may additionally be re-configured in firmware as some other PMOD types.

Signals on PMOD B are shared with Main MCU pin header J1 and J2. Care must be taken to ensure that shared signals are not used concurrently.

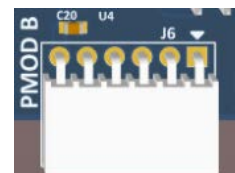

Table 8. PMOD B Connector (J6)

| PMOD B Connector | | EK-RA2A1 |
|------------------|---------------------|---|
| Pin | Description | Signal/Bus |
| 1 | CTS (from module) | U1 P410, CTS0_A (U1-13) |
| 2 | TXD | U1 P411, TXD0_F (U1-12) |
| 3 | RXD | U1 P204, RXD0_C (U1-24) |
| 4 | RTS (from Main MCU) | U1 P401, GPIO (U1-2) (for RTS by Main MCU firmware) |
| 5 | GND | GND |
| 6 | VCC | +3V3 |

Limits of the 3.3V regulator , and limits of the power source supplying that regulator (especially for USB Host devices), including the to-be-connected PMOD device, must be considered prior to connecting a module to a PMOD connector.

5.4.8 User Capacitive Touch Button

A capacitive sensor region for use as a Capacitive Touch button is provided in the board USER INPUT region. To disconnect the Capacitive Touch Button from the MCU, copper jumper E2 must be open. To connect MCU signal P001 to pin header J3, copper jumper E5 must be closed.



Table 9. Capacitive Touch Button Sensor

| Designator | Function | MCU Control Port | MCU Pin |
|------------|-------------------------|-------------------|---------|
| TS1 | Capacitive Touch Button | U1 P001 (TS15) | U1-62 |
| - | TSCAP Support | U1 P409 (TSCAP-E) | U1-14 |

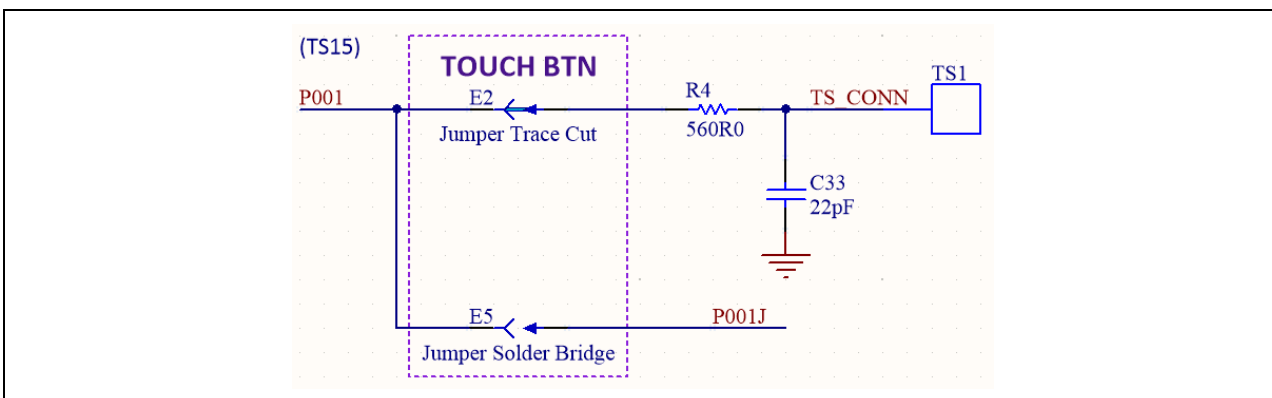

Figure 20. Capacitive Touch Button Circuit

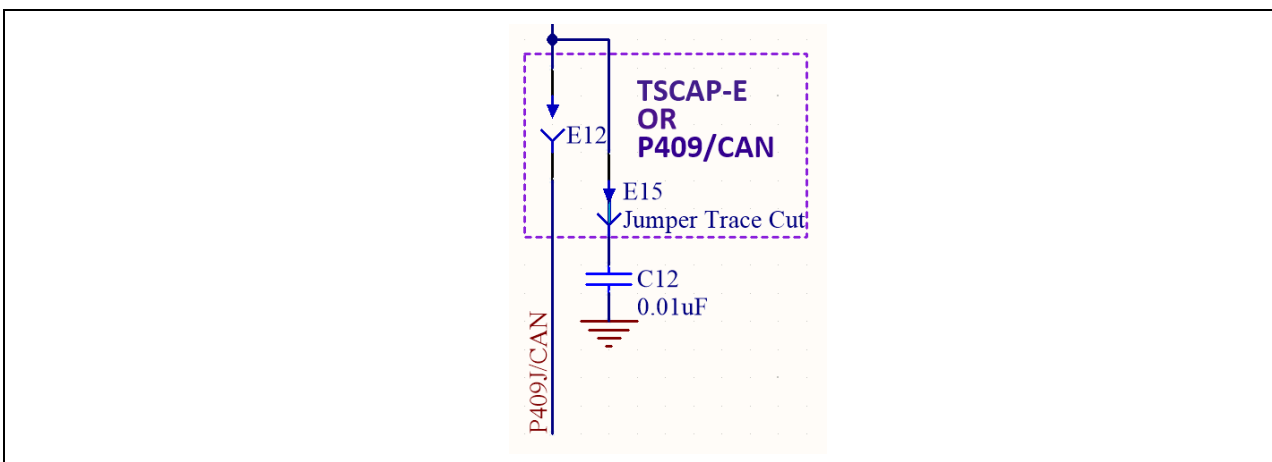

Figure 21. Capacitive Touch TSCAP Circuit



Figure 22. Capacitive Touch Button on Evaluation Kit Board (Top)

5.5 Pin Headers

Pin headers, J1, J2, J3, and J4, provide access to all Main MCU interface signals, and to voltages for all Main MCU power ports.

On EK-RA2A1, 40 pins of the pin headers are set aside for **fixed function** assignment. These pins are odd-numbered pins of J1 and even-numbered pins of J2.

Pin Header Fixed Function Pins are labeled with dark text on a white background. Pins that are not Fixed Function pins are labeled with white text on a dark background. On the top side of the board is the functional label for the fixed location. On the bottom side of the board is the port information for the same pin.



Figure 23. Fixed Function Pin Label Example

Primary Fixed Function Pins share the same functionality across EK-RA6M1, EK-RA6M2, EK-RA4M1, and EK-RA2A1 boards.

Secondary Fixed Function Pins share common pin assignments with other Renesas RA Family Evaluation Kits that have Main MCUs with the same functionality. The Secondary Fixed Function Pins are also labeled with the top side having a functional label, and bottom side having a port label.

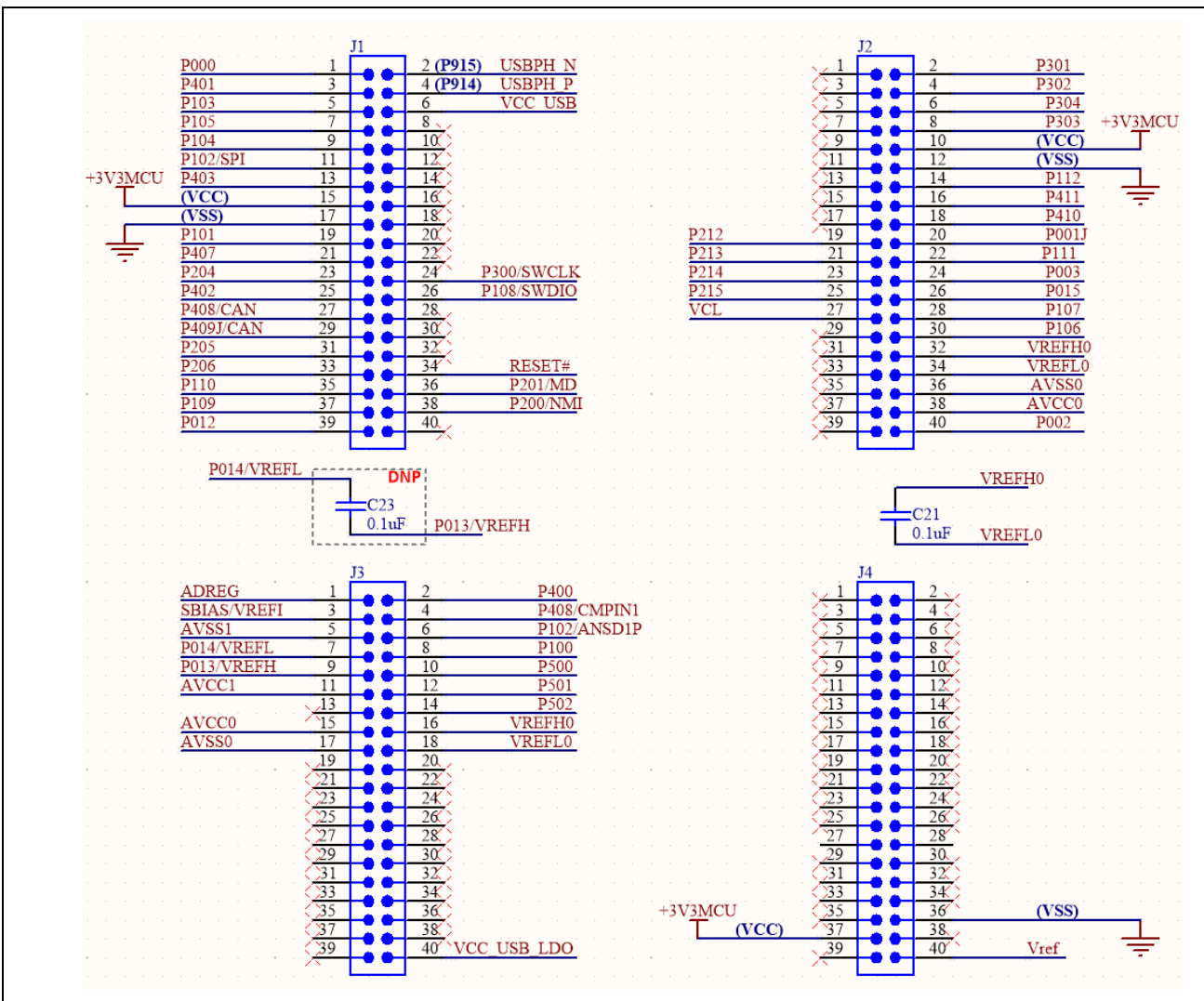

Figure 24. EK-RA2A1 Pin Headers Circuit

5.5.1 Pin Header J1

Pin Header J1 is a 2-column by 20-row through-hole header on 2.54 mm centers.

Table 10. Pin Header J1 Pin Assignment

| 64p Pin | Port/Signal | J1 Pins | | Port/Signal | 64p Pin |
|---------|------------------------|---------|----|-------------|---------|
| 63 | P000/SCL0_C (IIC) | 1 | 2 | P915/USB_DM | 38 |
| 2 | P401/SDA0_C (IIC) | 3 | 4 | P914/USB_DP | 39 |
| 45 | P103/RSPCKB_C (SPI) | 5 | 6 | VCC_USB | 40 |
| 43 | P105/MOSIB_C (SPI) | 7 | 8 | (None) | NC |
| 44 | P104/MISOB_C (SPI) | 9 | 10 | (None) | NC |
| 46 | P102/SSLB0_C (SPI) | 11 | 12 | (None) | NC |
| 4 | P403/SSLB3_A (SPI) | 13 | 14 | (None) | NC |
| 11 | VCC | 15 | 16 | (None) | NC |
| 8 | VSS | 17 | 18 | (None) | NC |
| 47 | P101/RXD9_C (SCI 2nd) | 19 | 20 | (None) | NC |
| 16 | P407/TXD9_A (SCI 2nd) | 21 | 22 | (None) | NC |
| 24 | P204/SCK9_B (SCI 2nd) | 23 | 24 | P300/SWCLK | 32 |
| 3 | P402/CTS_RTS (SCI 2nd) | 25 | 26 | P108/SWDIO | 33 |
| 15 | P408/CRX0_B (CAN) | 27 | 28 | (None) | NC |
| 14 | P409/CTX0_B (CAN) | 29 | 30 | (None) | NC |
| 23 | P205/GTIOC3B_A | 31 | 32 | (None) | NC |
| 22 | P206/GTIOC3A_A | 33 | 34 | RES | 25 |
| 34 | P110/RXD9 | 35 | 36 | P201/MD | 26 |
| 64 | P109/TXD9 | 37 | 38 | P200/NMI | 27 |
| 55 | P012/AN008 | 39 | 40 | (None) | NC |

Color Key

| |
|-------------------------------|
| Primary Fixed Function Pins |
| Secondary Fixed Function Pins |

5.5.2 Pin Header J2

Pin Header J2 is a 2-column by 20-row through-hole header on 2.54 mm centers.

Table 11. Pin Header J2 Pin Assignment

| 64p Pin | Port/Signal | J2 Pins | | Port/Signal | 64p Pin |
|---------|-------------|---------|----|------------------------|---------|
| NC | (None) | 1 | 2 | P301/RXD0_B (SCI 1st) | 31 |
| NC | (None) | 3 | 4 | P302/TXD0_B (SCI 1st) | 30 |
| NC | (None) | 5 | 6 | P304/SCK0_B (SCI 1st) | 28 |
| NC | (None) | 7 | 8 | P303/CTS_RTS (SCI 1st) | 29 |
| NC | (None) | 9 | 10 | VCC | 11 |
| NC | (None) | 11 | 12 | VSS | 8 |
| NC | (None) | 13 | 14 | P112/TSCAP_B/CLKOUT_B | 36 |
| NC | (None) | 15 | 16 | P411/TS04 | 12 |
| NC | (None) | 17 | 18 | P410/TS05 | 13 |
| 20 | P212/EXTAL | 19 | 20 | P001/TS15 | 62 |

| 64p Pin | Port/Signal | J2 Pins | | Port/Signal | 64p Pin |
|---------|-------------|---------|----|-------------|---------|
| 19 | P213/XTAL | 21 | 22 | P111/TS14 | 35 |
| 17 | P214/XCOUT | 23 | 24 | P003/AN006 | 60 |
| 16 | P215/XCIN | 25 | 26 | P015/AN003 | 52 |
| 15 | VCL | 27 | 28 | P107/AN023 | 41 |
| 14 | VBAT | 29 | 30 | P106/AN022 | 42 |
| NC | (None) | 31 | 32 | VREFH0 | 59 |
| NC | (None) | 33 | 34 | VREFL0 | 58 |
| NC | (None) | 35 | 36 | AVSS0 | 57 |
| NC | (None) | 37 | 38 | AVCC0 | 56 |
| NC | (None) | 39 | 40 | P002/DA8_1 | 61 |

Color Key

| |
|-------------------------------|
| Primary Fixed Function pins |
| Secondary Fixed Function pins |

5.5.3 Pin Header J3

Pin header J3 is a 2-column by 20-row through-hole header on 2.54 mm centers.

Table 12. Pin Header J3 Pin Assignment

| 64p Pin | Port/Signal | J3 Pins | | Port/Signal | 64p Pin |
|---------|-------------|---------|----|-------------|---------|
| 37 | ADREG | 1 | 2 | P400/CMPIN0 | 1 |
| 38 | SBIAS/AVREF | 3 | 4 | P408/CMPIN1 | 15 |
| 40 | AVSS1 | 5 | 6 | P102/ANSD1P | 46 |
| 53 | P014/VREFL | 7 | 8 | P100/ANSD0P | 48 |
| 54 | P013/VREFH | 9 | 10 | P500/AN000 | 49 |
| 39 | AVSS1 | 11 | 12 | P501/AN001 | 50 |
| NC | (None) | 13 | 14 | P502/AN002 | 51 |
| 56 | AVCC0 | 15 | 16 | VREFH0 | 59 |
| 57 | AVSS0 | 17 | 18 | VFERL0 | 58 |
| NC | (None) | 19 | 20 | (None) | NC |
| NC | (None) | 21 | 22 | (None) | NC |
| NC | (None) | 23 | 24 | (None) | NC |
| NC | (None) | 25 | 26 | (None) | NC |
| NC | (None) | 27 | 28 | (None) | NC |
| NC | (None) | 29 | 30 | (None) | NC |
| NC | (None) | 31 | 32 | (None) | NC |
| NC | (None) | 33 | 34 | (None) | NC |
| NC | (None) | 35 | 36 | (None) | NC |
| NC | (None) | 37 | 38 | (None) | NC |
| NC | (None) | 39 | 40 | VCC_USB_LDO | 41 |

Color Key

| |
|-------------------------------|
| Analog Front End Pins |
| Secondary Fixed Function Pins |

5.5.4 Pin Header J4

Pin Header J4 is a 2-column by 20-row through-hole header on 2.54 mm centers.

Table 13. Pin Header J4 Pin Assignment

| 64p Pin | Port/Signal | J4 Pins | | Port/Signal | 64p Pin |
|---------|-------------|---------|--------|-------------|---------|
| NC | (None) | 1 | 2 | (None) | NC |
| NC | (None) | 3 | 4 | (None) | NC |
| NC | (None) | 5 | 6 | (None) | NC |
| NC | (None) | 7 | 8 | (None) | NC |
| NC | (None) | 9 | 10 | (None) | NC |
| NC | (None) | 11 | 12 | (None) | NC |
| NC | (None) | 13 | 14 | (None) | NC |
| NC | (None) | 15 | 16 | (None) | NC |
| NC | (None) | 17 | 18 | (None) | NC |
| NC | (None) | 19 | 20 | (None) | NC |
| NC | (None) | 21 | 22 | (None) | NC |
| NC | (None) | 23 | 24 | (None) | NC |
| NC | (None) | 25 | 26 | (None) | NC |
| NC | (None) | 27 | 28 | (None) | NC |
| NC | (None) | 29 | 30 | (None) | NC |
| NC | (None) | 31 | (None) | (None) | NC |
| NC | (None) | 33 | (None) | (None) | NC |
| NC | (None) | 35 | 36 | VSS | 8 |
| 11 | VCC | 37 | (None) | (None) | NC |
| NC | (None) | 39 | 40 | Vref 2.048V | Vref |

Color Key

| |
|---------------------------------|
| Secondary Fixed Function pins |
| Analog Voltage Reference 2.048V |

5.6 Additional Features

5.6.1 Analog Reference Voltages

Footprints for the installation of capacitors C21 and C23 are provided on the board. These two capacitors provide noise-bypass capability for ports VREFH0/VREFL0 and for ports P013(VREFH)/P014(VREFL) correspondingly. See Figure 24 for the circuit design.



Port pair P013/P014 may be assigned as GPIO, where bypass capacitor C21 would damage signal quality. When P013/P014 are to be assigned as VREFH/VREFL, installation of capacitor C21 can reduce reference voltage noise and improve ADC measurement and DAC output quality.

5.6.2 On-Board Clock Crystals

The EK-RA2A1 board includes two precision crystal clock sources. A precision 12.000 MHz crystal is installed at location X1, and a precision 32.768 kHz crystal is installed at location X2. These crystal clock sources are connected to the Main MCU by default.

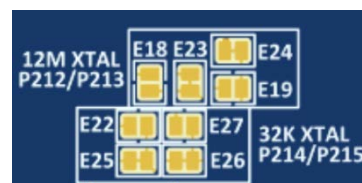

The MCU pins for the 12 MHz clock crystal may be connected to P212 and P213. To disconnect the 12 MHz crystal, open copper jumpers E23 and E24, and close copper jumpers E18 and E19.

The MCU pins for the 32.768 kHz clock crystal may be connected to P214 and P215. To disconnect the 32.768 kHz crystal, open copper jumpers E25 and E26, and close copper jumpers E22 and E27.

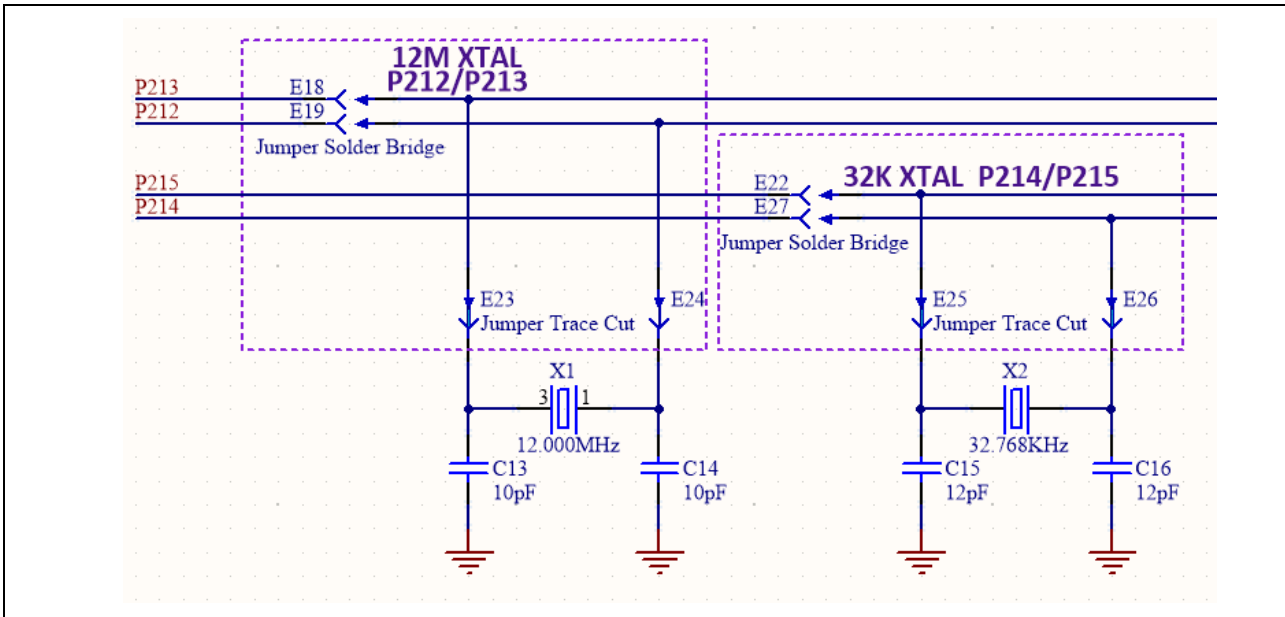

Figure 25. Crystal Clock Sources

5.6.3 User Potentiometer

A footprint for installation of a potentiometer and a recommended noise-bypass capacitor are provided on the board. The footprint was designed for installation of a Bourns P/N 3352T-1-103LF, or equivalent, as the potentiometer, and a Samsung P/N CL10B104KB8NANC, or similar, as the noise-bypass capacitor.

When the User Potentiometer is installed, copper jumper E36 must be closed to connect the User Potentiometer to the MCU.

Table 14. User Potentiometer on the Evaluation Kit Board

| Designator | Function | MCU Control Port | MCU Pin |
|------------|--------------------|------------------|---------|
| POT1 | User Potentiometer | U1 P003 (AN006) | U1-60 |

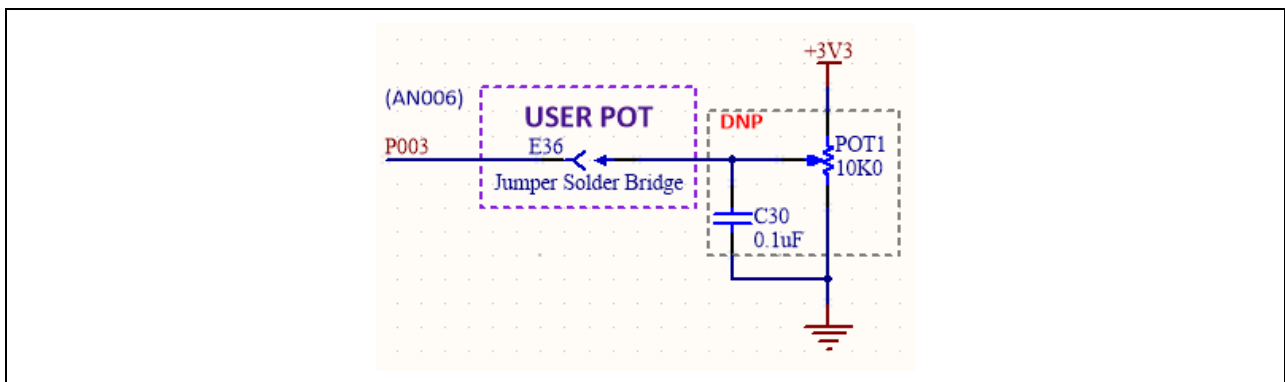

Figure 26 User Potentiometer Circuit



Figure 27. User Potentiometer on Evaluation Kit Board (Top)

5.6.4 Boot Configuration

The BOOT CONFIG jumper, J8, is used to configure the operating mode of the RA2A1 MCU at boot.

Table 15. Boot Configuration

| Boot Configuration | J8 Shunt Location |
|-----------------------|-------------------|
| Normal Boot (default) | Pins 1 and 2 |
| SCI/USB Boot | Pins 1 and 3 |

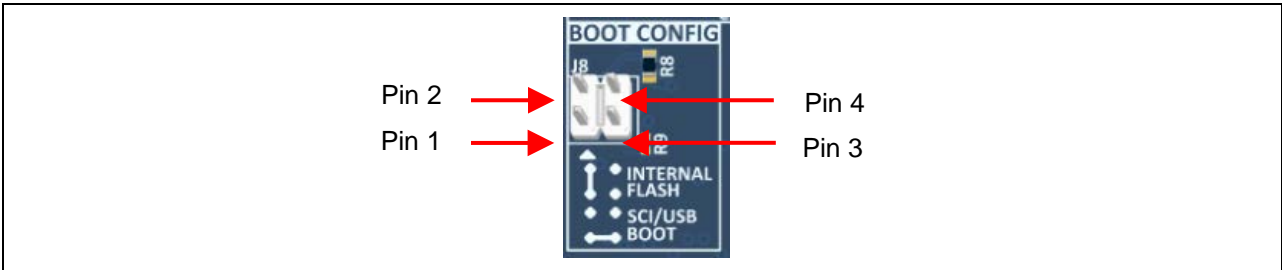

Figure 28. Boot Config Jumper J8

5.6.5 Miscellaneous Signals

5.6.5.1 AVCC0/AVSS0 and AVCC1/AVSS1

By default, AVCC0 and AVCC1 are connected to +3V3MCU, and AVSS0 and AVSS1 are connected to the system ground. To disconnect the reference voltage from AVCC0 and AVSS0, copper jumpers E10 and E11 must be open. To disconnect the reference voltage from AVCC1 and AVSS1, copper jumpers E45 and E46 must be open.

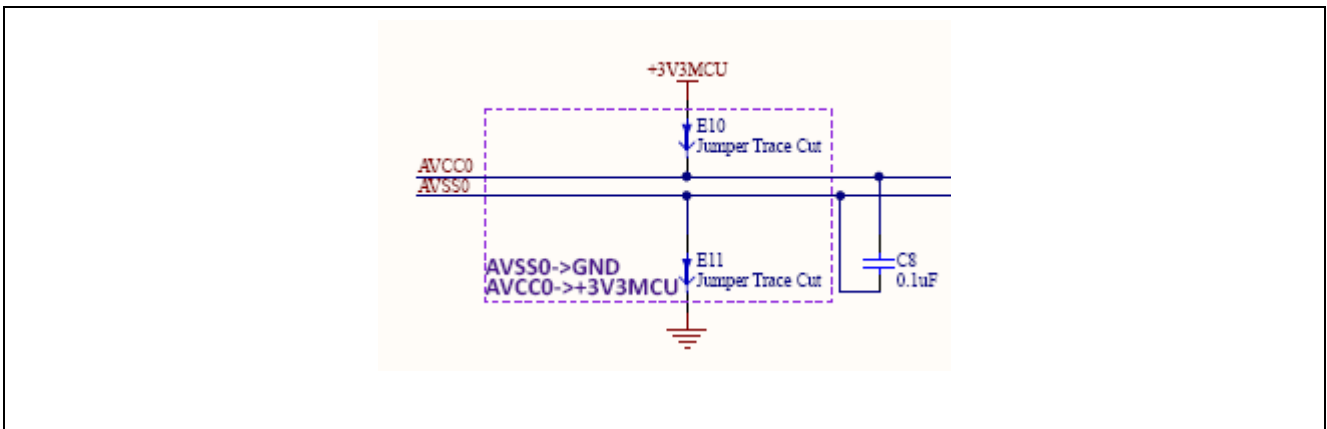

Figure 29. AVCC0/AVSS0 Circuit

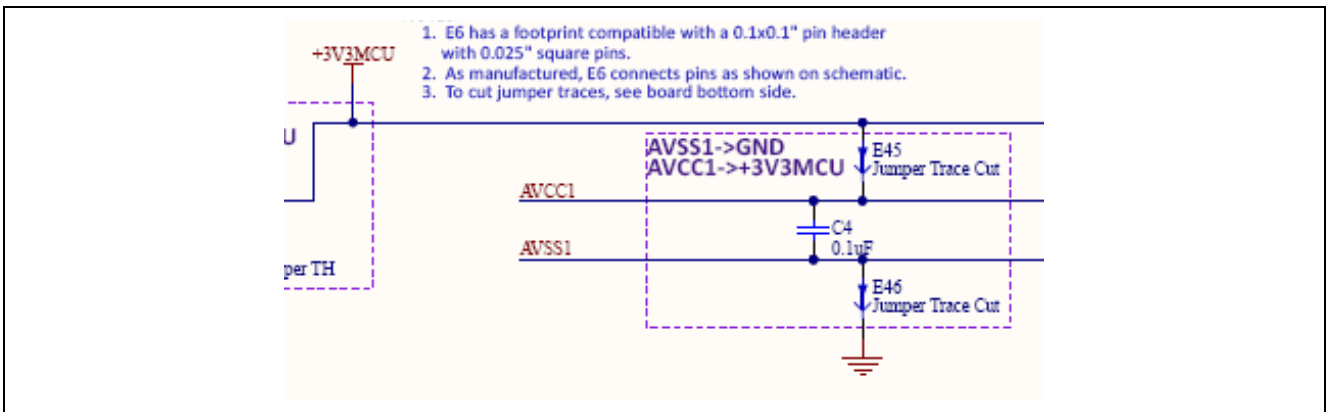

Figure 30. AVCC1/AVSS1 Circuit

5.6.5.2 VCL

By default, the Main MCU pin VCL is connected to reference capacitor C17. To connect this pin to MCU pin header J2, solder bridge E28 must be closed. To disconnect the reference capacitor C17, copper jumper E29 must be open.

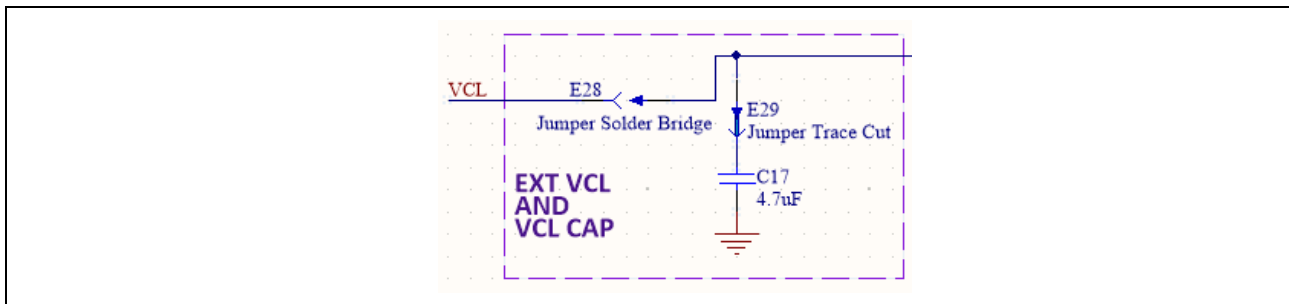

Figure 31. External Capacitor to VCL Circuit

5.6.5.3 VCC_USB_LDO

By default, the Main MCU pin VCC_USB_LDO is connected to the +3V3 MCU supply voltage. Alternatively, this pin may be connected to MCU Pin Header J3. To do this, copper jumper E7 must be open, and copper jumper E13 must be closed.

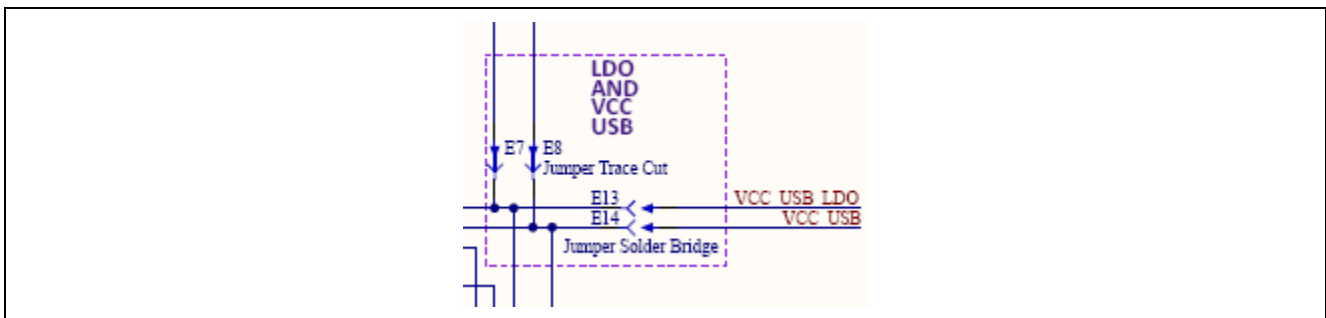

Figure 32. VCC_USB_LDO Circuit

5.6.5.4 VCC_USB

By default, the Main MCU pin VCC_USB is connected to the +3V3 MCU supply voltage. Alternatively, this pin may be connected to MCU Pin Header J1. To do this, copper jumper E8 must be open, and copper jumper E14 must be closed.

5.6.5.5 Signal P409/CAN

By default, the Main MCU pin P409 is connected to a TSCAP-E capacitor. This pin may be connected to MCU Pin Header J1. To do this, copper jumper E12 must be closed. The TSCAP-E capacitor may be disconnected by making copper jumper E15 open.

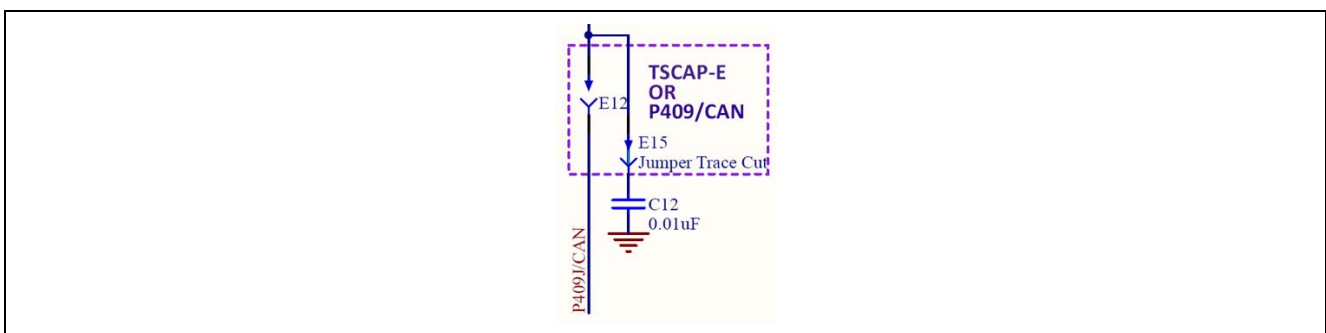

Figure 33. P409/CAN Circuit

5.6.5.6 Signal P408/CMPIN1/CAN

By default, the Main MCU pin P408 is connected to both CAN and CMPIN1. P408/CAN is connected to J1, and P408/CMPIN1 is connected to J3. To disconnect P408/CAN from J1, copper jumper E41 must be open. To disconnect P408/CMPIN1 from J3, copper jumper E42 must be open.

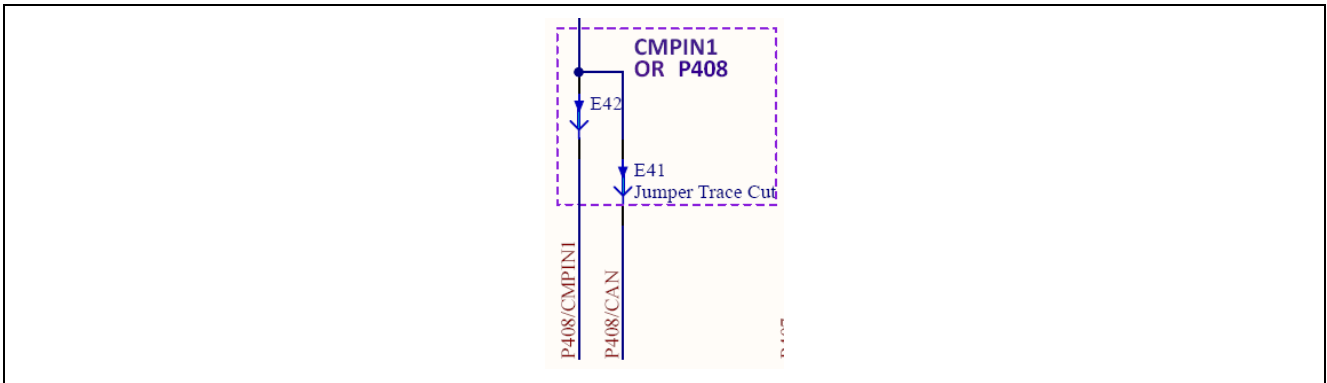

Figure 34. P408/CMPIN1/CAN Circuit

5.6.5.7 Signal P102/SPI/ANSD1P

By default, the Main MCU pin P102 is connected to both SPI and ANSD1P. P102/SPI is connected to J1, and P102/ANSD1P is connected to J3. To disconnect P102/SPI from J1, copper jumper E43 must be open. To disconnect P102/ANSD1P from J3, copper jumper E44 must be open.

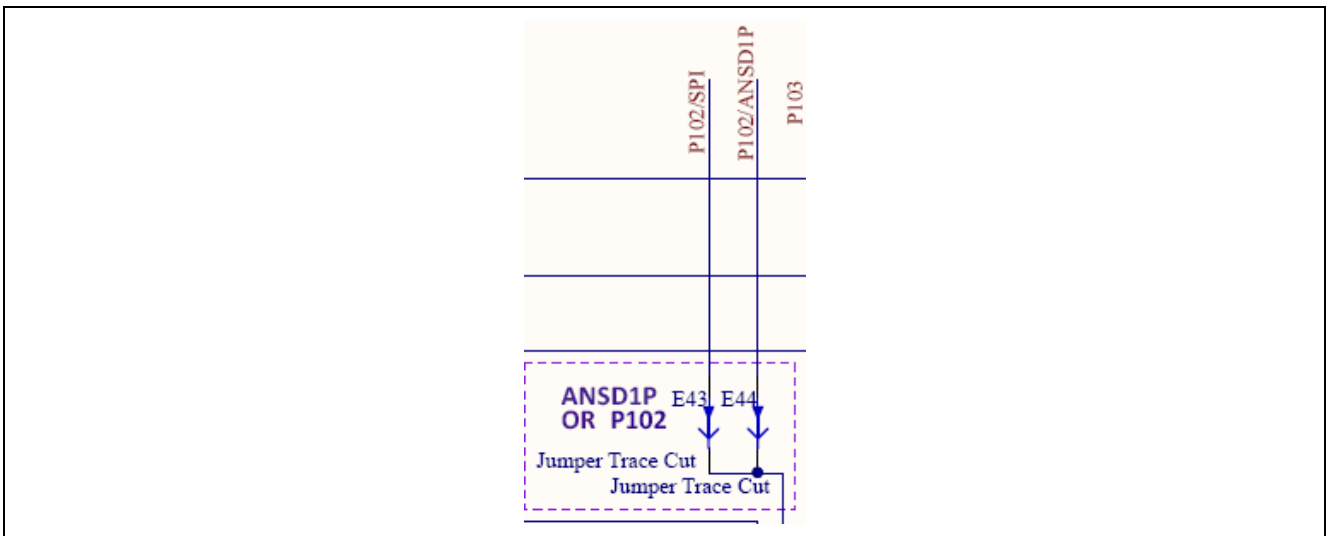

Figure 35. P102/SPI/ANSD1P Circuit

6. Certifications

The EK-RA2A1 v1 meets the following certifications/standards. See page 3 of this User's Manual for the disclaimer and precautions.

6.1 EMC/EMI Standards

- FCC Notice (Class A)



This device complies with part 15 of the FCC Rules. Operation is subject to the following two conditions: (1) This device may not cause harmful interference, and (2) this device must accept any interference received, including interference that may cause undesired operation.

NOTE- This equipment has been tested and found to comply with the limits for a Class A digital device, pursuant to Part 15 of the FCC Rules. These limits are designed to provide reasonable protection against harmful interference in a residential installation. This equipment generates, uses and can radiate radio frequency energy and, if not installed and used in accordance with the instructions, may cause harmful interference to radio communications. However, there is no guarantee that interference will not occur in a particular installation. If this equipment does cause harmful interference to radio or television reception, which can be determined by turning the equipment off and on, the user is encouraged to try to correct the interference by one or more of the following measures:

- Reorient or relocate the receiving antenna.
- Increase the separation between the equipment and receiver.
- Connect the equipment into an outlet on a circuit different from that to which the receiver is connected.
- Consult the dealer or an experienced radio/television technician for help.

- Innovation, Science and Economic Development Canada ICES-003 Compliance:
CAN ICES-3 (A)/NMB-3(A)

- CE Class A (EMC)



This product is herewith confirmed to comply with the requirements set out in the Council Directives on the Approximation of the laws of the Member States relating to electromagnetic Compatibility Directive 2004/108/EEC.

Warning – This is a Class A product. In a domestic environment this product may cause radio interference in which case the user may be required to take adequate measures to correct this interference.

- Taiwan: Chinese National Standard 13438, C6357 compliance, Class A limits
- Australia/New Zealand AS/NZS CISPR 32:2015, Class A

6.2 Material Selection, Waste, Recycling and Disposal Standards

- EU RoHS
- China SJ/T 113642014, 10-year environmental protection use period.

6.3 Safety Standards

- UL 94V-0

7. Design and Manufacturing Information

The design and manufacturing information about EK-RA2A1 v1 board are available in the “EK-RA2A1v1 Design Package” available on renesas.com/ra/ek-ra2a1.

- Design package file name: ek-ra2a1-v1-designpackage.zip
- Design package contents

| File Type | Content | File/Folder Name |
|------------|---------------------|------------------------|
| File (PDF) | Schematics | ek-ra2a1-v1-schematics |
| File (PDF) | Mechanical Drawing | ek-ra2a1-v1-mechdwg |
| File (PDF) | 3D Drawing | ek-ra2a1-v1-3d |
| File (PDF) | BOM | ek-ra2a1-v1-bom |
| Folder | Manufacturing Files | Manufacturing Files |
| Folder | Design Files | Design Files - Altium |

8. Website and Support

Visit the following URLs to learn about the kit and the RA family of microcontrollers, download tools and documentation, and get support.

| | |
|--------------------------|---|
| EK-RA2A1 Resources | renesas.com/ra/ek-ra2a1 |
| RA Product Information | renesas.com/ra |
| RA Product Support Forum | renesas.com/ra/forum |
| Renesas Support | renesas.com/support |

Revision History

| Rev. | Date | Description | |
|------|-----------|-------------|-----------------|
| | | Page | Summary |
| 1.00 | Oct.02.19 | - | Initial release |

EK-RA2A1 v1

Publication Date: Oct.02.19

Published by: Renesas Electronics Corporation

EK-RA2A1 v1 – User's Manual