

Cable sleeve - CES-SRG-BK-16 - 1410576

Please be informed that the data shown in this PDF Document is generated from our Online Catalog. Please find the complete data in the user's documentation. Our General Terms of Use for Downloads are valid (<http://phoenixcontact.com/download>)



Cable sleeve, no. of conductors: 1, length: 29.5 mm, width: 19.5 mm, height: 17 mm, external cable diameter: 1x 15 mm ... 16 mm , color: black

Product Description

Slotted cable sleeve



Key Commercial Data

| | |
|--------------------------------------|---|
| Packing unit | 10 pc |
| Minimum order quantity | 10 pc |
| GTIN |  4 046356 797009 |
| GTIN | 4046356797009 |
| Weight per Piece (excluding packing) | 4.940 g |
| Custom tariff number | 40169300 |
| Country of origin | Taiwan |

Technical data

Dimensions

| | |
|-------------------------|--------------------|
| External cable diameter | 1x 15 mm ... 16 mm |
| Length | 29.5 mm |
| Width | 19.5 mm |
| Height | 17 mm |

Ambient conditions

| | |
|---------------------------------|----------------------------|
| Degree of protection | IP54 |
| Ambient temperature (operation) | -40 °C ... 125 °C (static) |

General

| | |
|-------------------|-----|
| No. of conductors | 1 |
| Material | NBR |
| | NBR |

Cable sleeve - CES-SRG-BK-16 - 1410576

Technical data

General

| | |
|-------|-------|
| Color | black |
|-------|-------|

Environmental Product Compliance

| | |
|------------|---|
| China RoHS | Environmentally friendly use period: unlimited = EFUP-e |
| | No hazardous substances above threshold values |

Drawings

Dimensional drawing

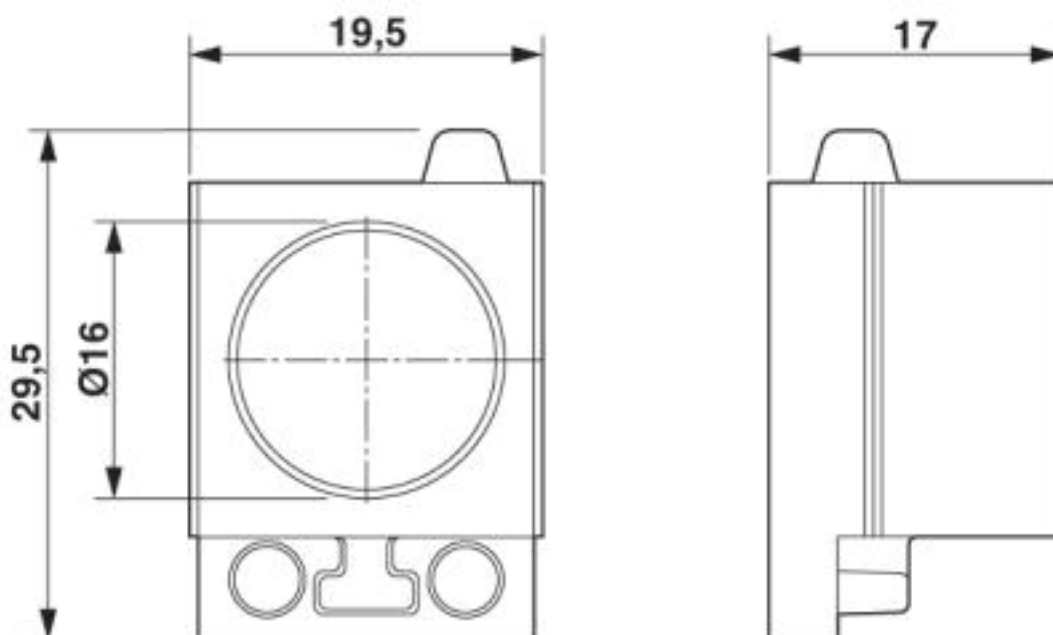

Dimensional drawing

Classifications

eCl@ss

| | |
|---------------|----------|
| eCl@ss 10.0.1 | 27144425 |
| eCl@ss 4.0 | 27081000 |
| eCl@ss 4.1 | 27081000 |
| eCl@ss 5.0 | 27081000 |
| eCl@ss 5.1 | 27081000 |
| eCl@ss 6.0 | 27081000 |
| eCl@ss 7.0 | 27069220 |
| eCl@ss 8.0 | 27069220 |
| eCl@ss 9.0 | 27144425 |

Cable sleeve - CES-SRG-BK-16 - 1410576

Classifications

ETIM

| | |
|----------|----------|
| ETIM 3.0 | EC000879 |
| ETIM 4.0 | EC002498 |
| ETIM 5.0 | EC000451 |
| ETIM 6.0 | EC000451 |
| ETIM 7.0 | EC000451 |

UNSPSC

| | |
|---------------|----------|
| UNSPSC 6.01 | 30212109 |
| UNSPSC 7.0901 | 39121708 |
| UNSPSC 11 | 39121708 |
| UNSPSC 12.01 | 39121708 |
| UNSPSC 13.2 | 39121448 |
| UNSPSC 18.0 | 39121448 |
| UNSPSC 19.0 | 39121448 |
| UNSPSC 20.0 | 39121448 |
| UNSPSC 21.0 | 39121448 |

Approvals

Approvals

Approvals

GL

Ex Approvals

Approval details

| | | | |
|----|--|---|------------|
| GL | | https://approvalfinder.dnvgl.com/ | 1391415 HH |
|----|--|---|------------|
