

Sensor/actuator box - SACB-4/ 8-M23 SH - 1695757

Please be informed that the data shown in this PDF Document is generated from our Online Catalog. Please find the complete data in the user's documentation. Our General Terms of Use for Downloads are valid (<http://phoenixcontact.com/download>)



Sensor/actuator box, application: Standard, connection method: M12 socket Metal, number of slots: 4, number of positions: 5, coding: A - standard, slot assignment: Double, status display: No, Universal; master cable connection: M23 plug connection 90°, shielding: yes

The figure shows a version with 8 slots

Your advantages

- Safety in the field, thanks to molded housing and high degree of protection
- Flexible, distributed bundling of signals in one master cable
- Save space: distributor box with double occupancy for two sensors in one slot
- Reliable signal transmission – 360° shielding in environments with electromagnetic interference



Key Commercial Data

| | |
|--------------------------------------|---|
| Packing unit | 1 pc |
| GTIN |  4 017918 899394 |
| GTIN | 4017918899394 |
| Weight per Piece (excluding packing) | 295.800 g |
| Custom tariff number | 85366990 |
| Country of origin | Poland |
| Note | Made to Order (non-returnable) |

Technical data

General

| | |
|--|---------|
| Rated voltage | 48 V AC |
| | 60 V DC |
| Current carrying capacity per I/O signal | 2 A |
| Current carrying capacity per slot | 4 A |
| Total rated current | 12 A |
| Number of positions | 5 |
| Number of slots | 4 |

Sensor/actuator box - SACB-4/ 8-M23 SH - 1695757

Technical data

General

| | |
|--|---|
| Flammability rating according to UL 94 | V0 |
| Sensor/actuator connection system | M12 socket |
| Note | NOTE: Observe the permissible bending radii when laying conductors, since the degree of protection may be put in jeopardy if the bending forces are too high. Alleviate mechanical loads upstream of the connector, e.g. by using cable ties. |
| | Unused slots are to be sealed off prior to commissioning. Suitable sealing elements are to be found under "Accessories". |

Ambient conditions

| | |
|---------------------------------|------------------|
| Degree of protection | IP65 |
| | IP67 |
| Ambient temperature (operation) | -25 °C ... 70 °C |

Master cable data/connection data

| | |
|--|---------------------|
| Connection method | M23 plug connection |
| Tightening torque slot sensor/actuator cable | 0.4 Nm |

Insulation material

| | |
|--|---------------|
| Housing material | Aluminum |
| Housing surface material | Nickel-plated |
| Material of the moulding mass | PUR |
| Contact material | Cu alloy |
| Contact surface material | gold-plated |
| Contact carrier material | PA |
| Material of contact, master cable side | CU alloy |
| Material of contact surface, master cable side | Gold-plated |
| Material of the contact carrier on the master cable side | PA 6.6 V0 |
| Material of threaded sleeve | Aluminum |
| O-ring material | NBR |

Pin assignment

| | |
|--|-----------------------|
| Slot/position = Wire color or connection | 1 / 4 (A) = 15 |
| | 1 / 2 (B) = 7 |
| | 2 / 4 (A) = 5 |
| | 2 / 2 (B) = 4 |
| | 3 / 4 (A) = 16 |
| | 3 / 2 (B) = 8 |
| | 4 / 4 (A) = 3 |
| | 4 / 2 (B) = 14 |
| | 1-4 / 1 (+ 48 V) = 19 |
| | 1-4 / 3 (0 V) = 6 |
| | 1-4 / 5 (PE) = 12 |

Standards and Regulations

Sensor/actuator box - SACB-4/ 8-M23 SH - 1695757

Technical data

Standards and Regulations

| | |
|--|-----------------|
| Standard designation | M12 connector |
| Standards/regulations | IEC 61076-2-101 |
| Flammability rating according to UL 94 | V0 |

Environmental Product Compliance

| | |
|------------|---|
| REACH SVHC | Lead 7439-92-1 |
| China RoHS | Environmentally Friendly Use Period = 50 |
| | For details about hazardous substances go to tab "Downloads", Category "Manufacturer's declaration" |

Drawings

Dimensional drawing

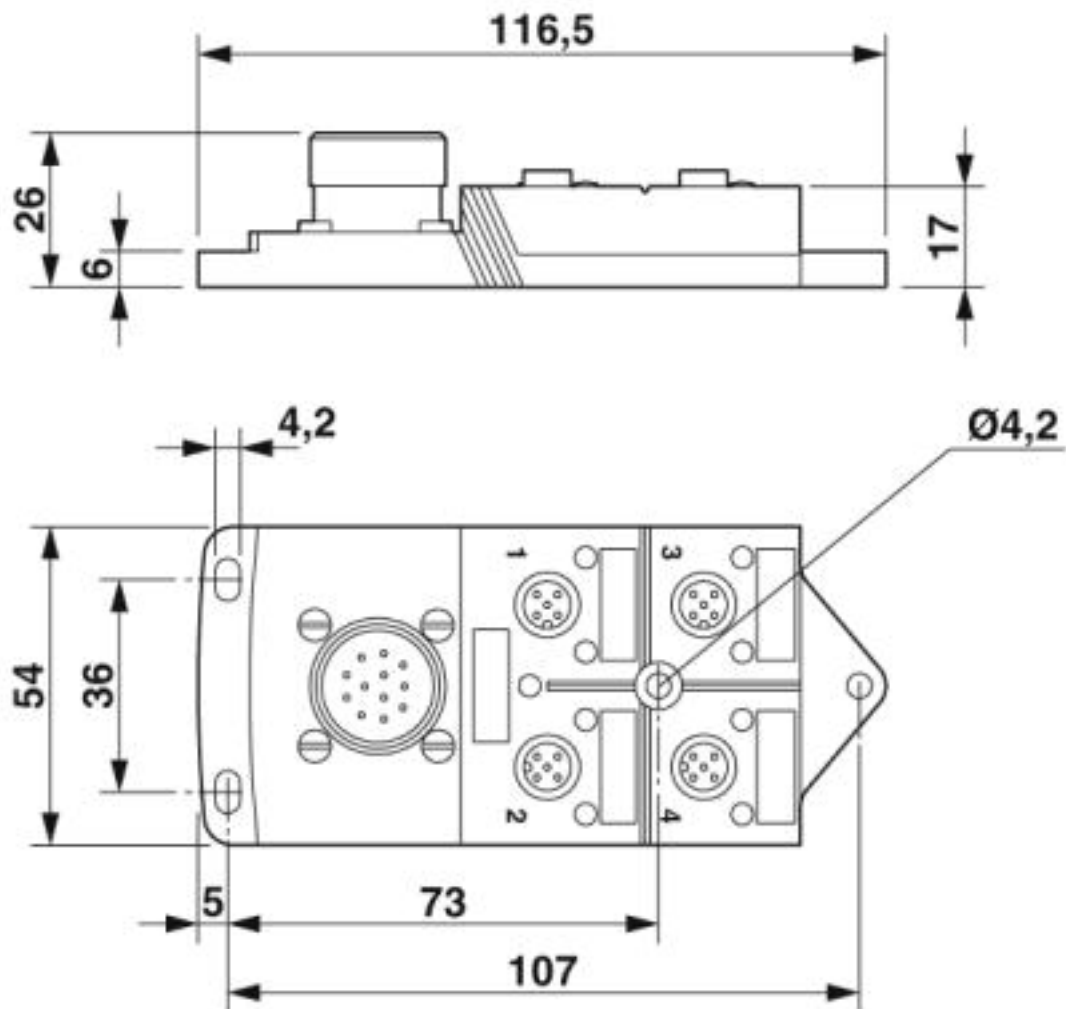

Sensor/actuator box - SACB-4/ 8-M23 SH - 1695757

Circuit diagram

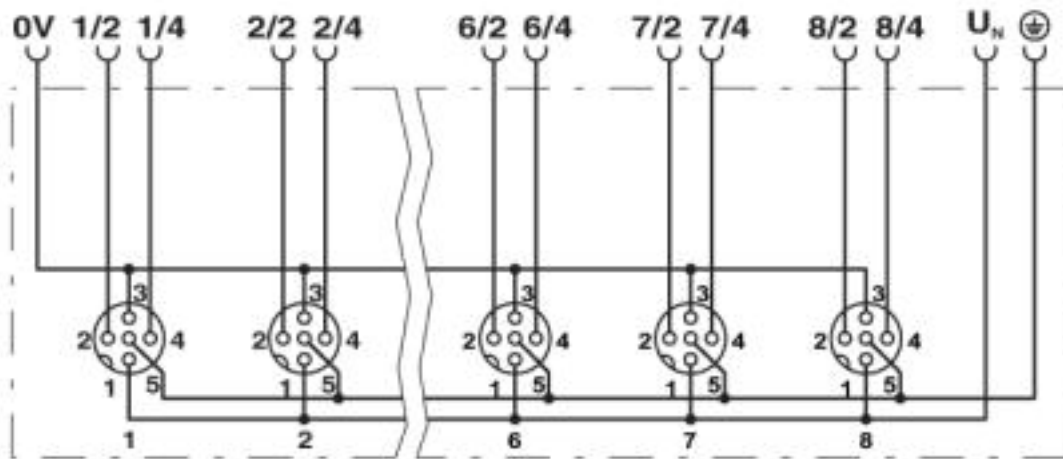

Schematic diagram

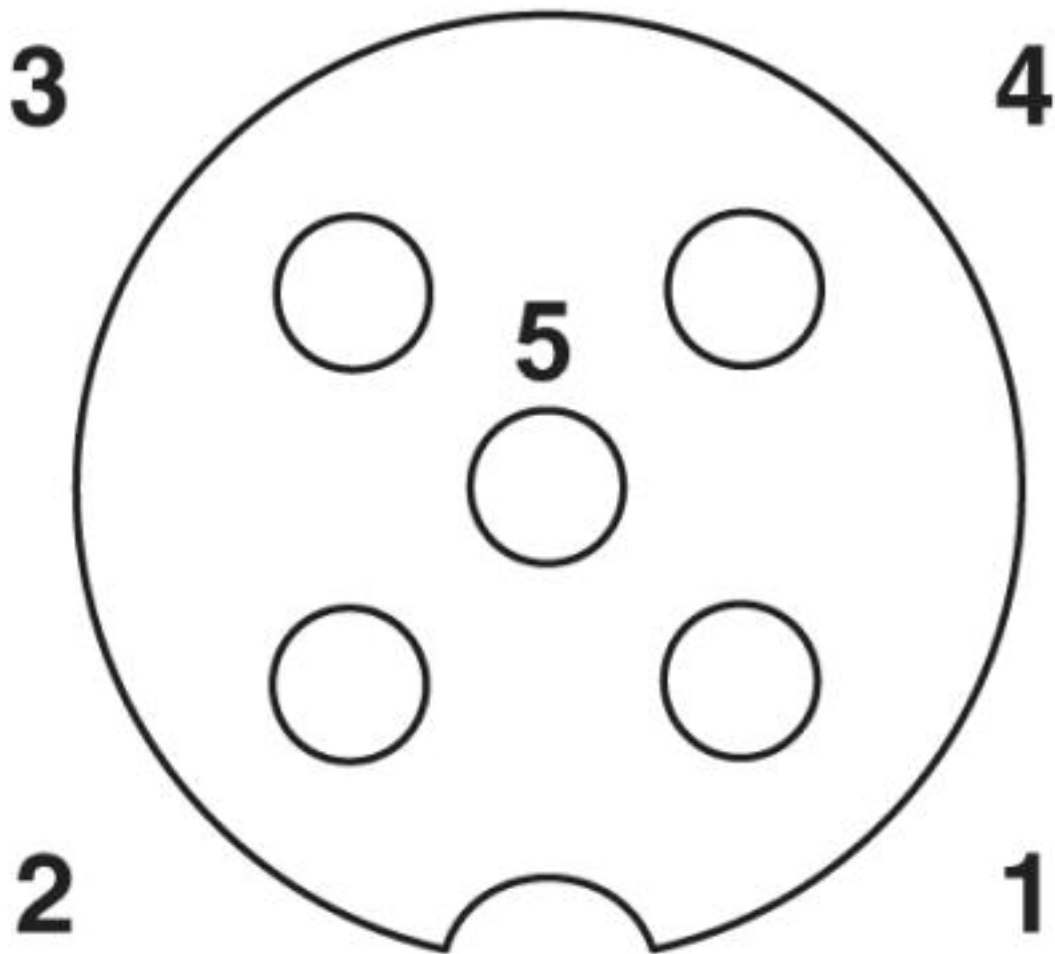

M12 slot, socket, 5-pos.

Sensor/actuator box - SACB-4/ 8-M23 SH - 1695757

Schematic diagram

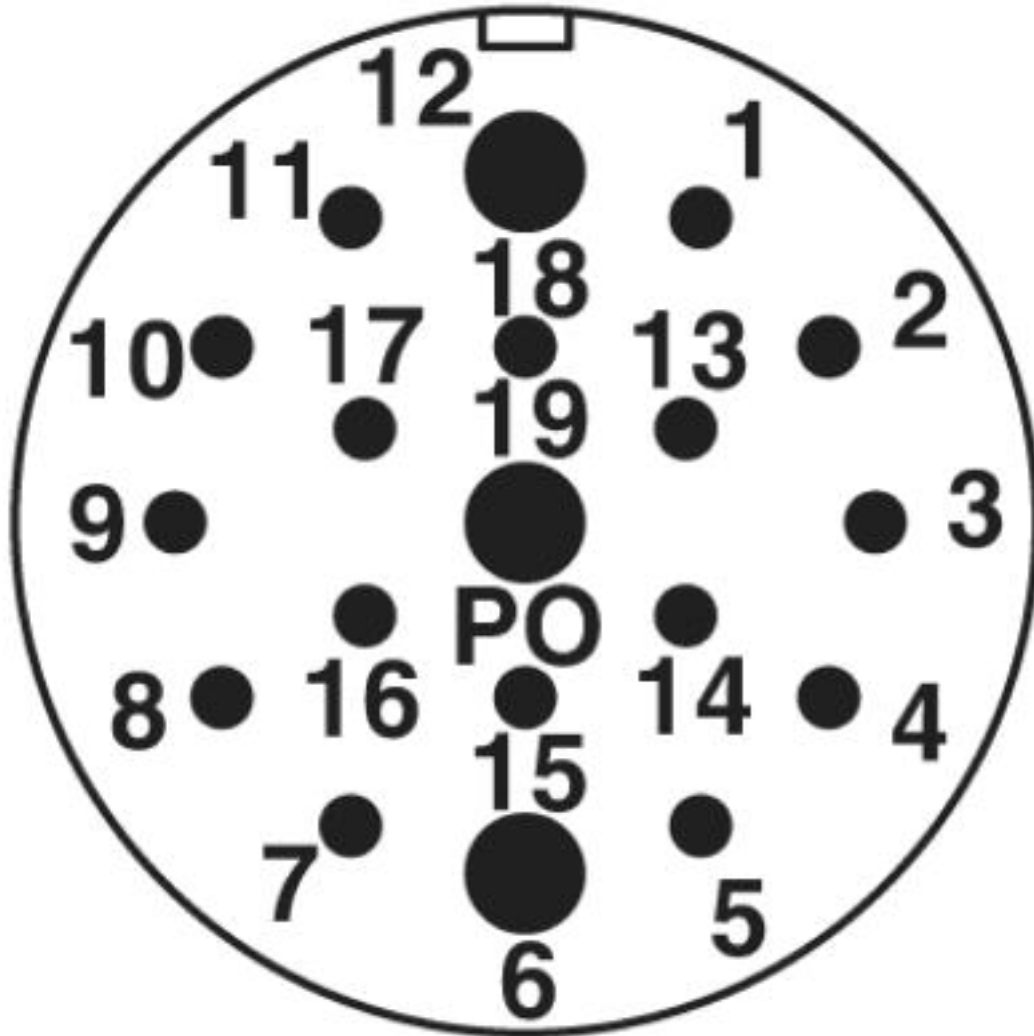

M23 plug connection pin, 19-pos.

Classifications

eCl@ss

| | |
|------------|----------|
| eCl@ss 4.0 | 27140800 |
| eCl@ss 4.1 | 27140800 |
| eCl@ss 5.0 | 27143400 |
| eCl@ss 5.1 | 27250300 |
| eCl@ss 6.0 | 27279200 |
| eCl@ss 7.0 | 27279219 |
| eCl@ss 8.0 | 27279219 |
| eCl@ss 9.0 | 27440108 |

Sensor/actuator box - SACB-4/ 8-M23 SH - 1695757

Classifications

ETIM

| | |
|----------|----------|
| ETIM 2.0 | EC000200 |
| ETIM 3.0 | EC001856 |
| ETIM 4.0 | EC002585 |
| ETIM 5.0 | EC002585 |
| ETIM 6.0 | EC002585 |
| ETIM 7.0 | EC002585 |

UNSPSC

| | |
|---------------|----------|
| UNSPSC 6.01 | 31261501 |
| UNSPSC 7.0901 | 31261501 |
| UNSPSC 11 | 31261501 |
| UNSPSC 12.01 | 31261501 |
| UNSPSC 13.2 | 31251501 |
| UNSPSC 19.0 | 31251501 |
| UNSPSC 20.0 | 31251501 |
| UNSPSC 21.0 | 31251501 |

Approvals

Approvals

Approvals

EAC

Ex Approvals

Approval details

| | | |
|-----|---|--------------------------|
| EAC |  | RU C- DE.AI30.B.01102 |
|-----|---|--------------------------|

Accessories

Accessories

Labeled terminal marker

Sensor/actuator box - SACB-4/ 8-M23 SH - 1695757

Accessories

Marker for terminal blocks - UC-TMF 16 CUS - 0824678



Marker for terminal blocks, can be ordered: by sheet, white, labeled according to customer specifications, mounting type: snap into flat marker groove, for terminal block width: 16 mm, lettering field size: 15.45 x 5.1 mm, Number of individual labels: 32

Marker for terminal blocks - UC-TMF 16 YE CUS - 0824684



Marker for terminal blocks, can be ordered: by sheet, yellow, labeled according to customer specifications, mounting type: snap into flat marker groove, for terminal block width: 16 mm, lettering field size: 15.45 x 5.1 mm, Number of individual labels: 32

Master cable, assembled

Master cable - RCK-TWGM/BL16+3/ 5,0PUR SH - 1519529



Socket M23, 19-pos., angled, shielded, with shielded, connected master cable, length: 5 m

Master cable - RCK-TWGM/BL16+3/10,0PUR SH - 1511828



Socket M23, 19-pos., angled, shielded, with shielded, connected master cable, length: 10 m

Female connector - RC/TGGM/KVD/LBL 16+3 - 1685505



Socket M23, 19-pos., straight, shielded, freely configurable, with solder connection, for external cable diameter 9.5 mm ... 14.5 mm

Sensor/actuator box - SACB-4/ 8-M23 SH - 1695757

Accessories

Female connector - RC/TWGM/KVD/LBL 16+3 - 1685518



Socket M23, 19-pos., angled, shielded, freely configurable, with solder connection, for external cable diameter 9.5 mm ... 14.5 mm

Plug for cable screw gland

Screw plug - PROT-M12 SH - 1503302



An M12 screw plug for the unoccupied M12 sockets of the shielded sensor/actuator cable, boxes and flush-type connectors

Protective cap

Protective cap - MSK 1 - 1665897



M23 metal sealing cap, for unoccupied M23 connectors, without steel wire

Protective cap - MSK 2 - 1665907



M23 metal sealing cap, for unoccupied M23 connectors, with steel wire

Protective cap - KSK 1 - 1685013



Plastic sealing cap, for unoccupied M23 connectors

Screwdriver tools

Sensor/actuator box - SACB-4/ 8-M23 SH - 1695757

Accessories

Adapter insert - TSD-M SAC-BIT ADAPTER - 1212600



Adapter bit for TSD-M...torque tools, E6.3-1/4" drive with 4 mm hexagon to accommodate SAC bits

Tool - SAC BIT M12-D15 - 1208432



Nut for assembling sensor/actuator cables with M12 connector and M12 connectors for assembly, with a knurl diameter of 15 mm, for 4 mm hexagonal drive

Tool - SACC BIT M12-D20 - 1208445



Nut for assembling M12 connectors for assembly with a knurl diameter of 20 mm, for 4 mm hexagonal drive

Terminal marking

Marker for terminal blocks - UC-TMF 16 - 0819262



Marker for terminal blocks, Sheet, white, unlabeled, can be labeled with: BLUEMARK ID COLOR, BLUEMARK ID, BLUEMARK CLED, PLOTMARK, CMS-P1-PLOTTER, mounting type: snap into flat marker groove, for terminal block width: 16 mm, lettering field size: 15.45 x 5.1 mm, Number of individual labels: 32

Marker for terminal blocks - UC-TMF 16 YE - 0819259



Marker for terminal blocks, Sheet, yellow, unlabeled, can be labeled with: BLUEMARK ID COLOR, BLUEMARK ID, BLUEMARK CLED, PLOTMARK, CMS-P1-PLOTTER, mounting type: snap into flat marker groove, for terminal block width: 16 mm, lettering field size: 15.45 x 5.1 mm, Number of individual labels: 32

Torque tool

Sensor/actuator box - SACB-4/ 8-M23 SH - 1695757

Accessories

Torque screwdriver - TSD 04 SAC - 1208429



Torque screwdriver, with preset torque of 0.4 Nm and 4 mm hexagonal drive for M12 connectors

Torque screwdriver - TSD-M 1,2NM - 1212224



Torque screw driver, accuracy as per EN ISO 6789 standard, adjustable from 0.3 - 1.2 Nm

Pipe spanner - PLUSCON-RCS - 1665062



Special pipe spanner, tool for mounting the M23 connector housing (with assembly), for coupling and sleeve housing
