



MICROCHIP

**dsPICDEM™ MCSM
Development Board
User's Guide**

Note the following details of the code protection feature on Microchip devices:

- Microchip products meet the specification contained in their particular Microchip Data Sheet.
- Microchip believes that its family of products is one of the most secure families of its kind on the market today, when used in the intended manner and under normal conditions.
- There are dishonest and possibly illegal methods used to breach the code protection feature. All of these methods, to our knowledge, require using the Microchip products in a manner outside the operating specifications contained in Microchip's Data Sheets. Most likely, the person doing so is engaged in theft of intellectual property.
- Microchip is willing to work with the customer who is concerned about the integrity of their code.
- Neither Microchip nor any other semiconductor manufacturer can guarantee the security of their code. Code protection does not mean that we are guaranteeing the product as "unbreakable."

Code protection is constantly evolving. We at Microchip are committed to continuously improving the code protection features of our products. Attempts to break Microchip's code protection feature may be a violation of the Digital Millennium Copyright Act. If such acts allow unauthorized access to your software or other copyrighted work, you may have a right to sue for relief under that Act.

Information contained in this publication regarding device applications and the like is provided only for your convenience and may be superseded by updates. It is your responsibility to ensure that your application meets with your specifications. MICROCHIP MAKES NO REPRESENTATIONS OR WARRANTIES OF ANY KIND WHETHER EXPRESS OR IMPLIED, WRITTEN OR ORAL, STATUTORY OR OTHERWISE, RELATED TO THE INFORMATION, INCLUDING BUT NOT LIMITED TO ITS CONDITION, QUALITY, PERFORMANCE, MERCHANTABILITY OR FITNESS FOR PURPOSE. Microchip disclaims all liability arising from this information and its use. Use of Microchip devices in life support and/or safety applications is entirely at the buyer's risk, and the buyer agrees to defend, indemnify and hold harmless Microchip from any and all damages, claims, suits, or expenses resulting from such use. No licenses are conveyed, implicitly or otherwise, under any Microchip intellectual property rights unless otherwise stated.

Trademarks

The Microchip name and logo, the Microchip logo, Adaptec, AnyRate, AVR, AVR logo, AVR Freaks, BesTime, BitCloud, chipKIT, chipKIT logo, CryptoMemory, CryptoRF, dsPIC, FlashFlex, flexPWR, HELDO, IGLOO, JukeBlox, KeeLoq, Klear, LANCheck, LinkMD, maXStylus, maXTouch, MediaLB, megaAVR, Microsemi, Microsemi logo, MOST, MOST logo, MPLAB, OptoLyzer, PackeTime, PIC, picoPower, PICSTART, PIC32 logo, PolarFire, Prochip Designer, QTouch, SAM-BA, SenGenuity, SpyNIC, SST, SST Logo, SuperFlash, Symmetricom, SyncServer, Tachyon, TempTracker, TimeSource, tinyAVR, UNI/O, Vectron, and XMEGA are registered trademarks of Microchip Technology Incorporated in the U.S.A. and other countries.

APT, ClockWorks, The Embedded Control Solutions Company, EtherSynch, FlashTec, Hyper Speed Control, HyperLight Load, IntelliMOS, Libero, motorBench, mTouch, Powermite 3, Precision Edge, ProASIC, ProASIC Plus, ProASIC Plus logo, Quiet-Wire, SmartFusion, SyncWorld, Temux, TimeCesium, TimeHub, TimePictra, TimeProvider, Vite, WinPath, and ZL are registered trademarks of Microchip Technology Incorporated in the U.S.A.

Adjacent Key Suppression, AKS, Analog-for-the-Digital Age, Any Capacitor, AnyIn, AnyOut, BlueSky, BodyCom, CodeGuard, CryptoAuthentication, CryptoAutomotive, CryptoCompanion, CryptoController, dsPICDEM, dsPICDEM.net, Dynamic Average Matching, DAM, ECAN, EtherGREEN, In-Circuit Serial Programming, ICSP, INICnet, Inter-Chip Connectivity, JitterBlocker, KlearNet, KlearNet logo, memBrain, Mindi, MiWi, MPASM, MPF, MPLAB Certified logo, MPLIB, MPLINK, MultiTRAK, NetDetach, Omniscient Code Generation, PICDEM, PICDEM.net, PICKit, PICtail, PowerSmart, PureSilicon, QMatrix, REAL ICE, Ripple Blocker, SAM-ICE, Serial Quad I/O, SMART-I.S., SQL, SuperSwitcher, SuperSwitcher II, Total Endurance, TSHARC, USBCheck, VariSense, ViewSpan, WiperLock, Wireless DNA, and ZENA are trademarks of Microchip Technology Incorporated in the U.S.A. and other countries.

SQTP is a service mark of Microchip Technology Incorporated in the U.S.A.

The Adaptec logo, Frequency on Demand, Silicon Storage Technology, and Symmcom are registered trademarks of Microchip Technology Inc. in other countries.

GestIC is a registered trademark of Microchip Technology Germany II GmbH & Co. KG, a subsidiary of Microchip Technology Inc., in other countries.

All other trademarks mentioned herein are property of their respective companies.

© 2009-2019, Microchip Technology Incorporated, All Rights Reserved.

ISBN: 978-1-5224-5025-2

For information regarding Microchip's Quality Management Systems, please visit www.microchip.com/quality.



dsPICDEM™ MCSM DEVELOPMENT BOARD USER'S GUIDE

Table of Contents

Preface	5
Introduction.....	5
Document Layout	5
Conventions Used in this Guide	6
Recommended Reading.....	7
The Microchip Website.....	8
Product Change Notification Service.....	8
Customer Support	8
Document Revision History	8
Chapter 1. Introduction	9
1.1 Overview	9
1.2 Features	11
1.3 What's Included	11
1.4 Reference Documents and Webinars	12
Chapter 2. Getting Started	13
2.1 Board Setup	13
2.2 Programming and Debugging Application Code	14
Chapter 3. Hardware	15
3.1 Hardware Architecture	15
3.2 Board Connectors	21
3.3 User Interface Hardware	24
Appendix A. Board Layout and Schematics	25
Appendix B. Electrical Specifications	31
Index	33
Worldwide Sales and Service	34

dsPICDEM™ MCSM Development Board User's Guide

NOTES:



Preface

NOTICE TO CUSTOMERS

All documentation becomes dated, and this manual is no exception. Microchip tools and documentation are constantly evolving to meet customer needs, so some actual dialogs and/or tool descriptions may differ from those in this document. Please refer to our website (www.microchip.com) to obtain the latest documentation available.

Documents are identified with a “DS” number. This number is located on the bottom of each page, in front of the page number. The numbering convention for the DS number is “DSXXXXXXXXA”, where “XXXXXXXX” is the document number and “A” is the revision level of the document.

For the most up-to-date information on development tools, see the MPLAB® IDE online help. Select the Help menu, and then Topics to open a list of available online help files.

INTRODUCTION

This preface contains general information that will be useful to know before using the dsPICDEM™ Motor Control Stepper Motor (MCSM) Development Board. Topics discussed in this preface include:

- [Document Layout](#)
- [Conventions Used in this Guide](#)
- [Recommended Reading](#)
- [The Microchip Website](#)
- [Customer Support](#)
- [Customer Support](#)
- [Document Revision History](#)

DOCUMENT LAYOUT

This user's guide describes how to use the dsPICDEM™ MCSM Development Board. The document is organized as follows:

- **Chapter 1. “Introduction”** – This chapter introduces the dsPICDEM™ MCSM Development Board and provides a brief overview of its features.
- **Chapter 2. “Getting Started”** – This chapter provides information on getting started with the dsPICDEM™ MCSM Development Board.
- **Chapter 3. “Hardware”** – This chapter describes the hardware on the dsPICDEM™ MCSM Development Board.
- **Appendix A. “Board Layout and Schematics”** – This appendix provides diagrams of the hardware layout, as well as schematic diagrams for the dsPICDEM™ MCSM Development Board.
- **Appendix B. “Electrical Specifications”** – This appendix provides pertinent electrical specifications for the dsPICDEM™ MCSM Development Board.

dsPICDEM™ MCSM Development Board User's Guide

CONVENTIONS USED IN THIS GUIDE

This manual uses the following documentation conventions:

DOCUMENTATION CONVENTIONS

Description	Represents	Examples
Arial font:		
Italic characters	Referenced books	<i>MPLAB® IDE User's Guide</i>
	Emphasized text	...is the <i>only</i> compiler...
Initial caps	A window	the Output window
	A dialog	the Settings dialog
	A menu selection	select Enable Programmer
Quotes	A field name in a window or dialog	"Save project before build"
Underlined, italic text with right angle bracket	A menu path	<u><i>File>Save</i></u>
Bold characters	A dialog button	Click OK
	A tab	Click the Power tab
N'Rnnnn	A number in verilog format, where N is the total number of digits, R is the radix and n is a digit.	4'b0010, 2'hF1
Text in angle brackets < >	A key on the keyboard	Press <Enter>, <F1>
Courier New font:		
Plain Courier New	Sample source code	#define START
	Filenames	autoexec.bat
	File paths	c:\mcc18\h
	Keywords	_asm, _endasm, static
	Command-line options	-Opa+, -Opa-
	Bit values	0, 1
	Constants	0xFF, 'A'
Italic Courier New	A variable argument	<i>file.o</i> , where <i>file</i> can be any valid filename
Square brackets []	Optional arguments	mcc18 [options] <i>file</i> [options]
Curly braces and pipe character: { }	Choice of mutually exclusive arguments; an OR selection	errorlevel {0 1}
Ellipses...	Replaces repeated text	var_name [, var_name...]
	Represents code supplied by user	void main (void) { ... }

RECOMMENDED READING

This user's guide describes how to use the dsPICDEM™ MCSM Development Board. The device-specific data sheets contain current information on programming the specific microcontroller or digital signal controller devices. Other useful documents are listed below. The following Microchip documents are available and recommended as supplemental reference resources:

MPLAB® XC16 C Compiler User's Guide (DS50002071)

This user's guide describes how to use the 16-bit MPLAB® XC16 C Compiler. Please visit www.microchip.com/compilers for more information.

MPLAB® X IDE User's Guide (DS50002027)

This document describes how to setup the MPLAB® X IDE software and use it to create projects and program devices.

MPLAB® XC16 Assembler, Linker and Utilities User's Guide (DS50002106)

This user's guide describes how to use GNU language tools to write code for 16-bit applications.

Readme Files

For the latest information on using other tools, read the tool-specific Readme files in the Readme subdirectory of the MPLAB® IDE installation directory. The Readme files contain updated information and known issues that may not be included in this user's guide.

dsPIC33/PIC24 Family Reference Manuals

A specific Family Reference Manual (FRM) is available for each module, which explains the operation of the dsPIC® DSC MCU family architecture and peripheral modules. The specifics of each device family are discussed in their respective data sheet.

dsPIC33CK64MP105 Motor Control Plug-In Module (PIM) Information Sheet for External Op Amp Configuration (DS50002848)

Information Sheet for External Op Amp Configuration. This information sheet provides information specific to the dsPIC33CK64MP105 External Op Amp Configuration Motor Control Plug-In Module (PIM).

To obtain any of these documents, visit the Microchip website at www.microchip.com.

dsPICDEM™ MCSM Development Board User's Guide

THE MICROCHIP WEBSITE

Microchip provides online support via our website at www.microchip.com. This website is used as a means to make files and information easily available to customers. The website contains the following information:

- **Product Support** – Data sheets and errata, application notes and sample programs, design resources, user's guides and hardware support documents, latest software releases and archived software
- **General Technical Support** – Frequently Asked Questions (FAQs), technical support requests, online discussion groups, Microchip consultant program member listing
- **Business of Microchip** – Product selector and ordering guides, latest Microchip press releases, listing of seminars and events, listings of Microchip sales offices, distributors and factory representatives

PRODUCT CHANGE NOTIFICATION SERVICE

Microchip's customer notification service helps keep customers current on Microchip products. Subscribers will receive e-mail notification whenever there are changes, updates, revisions or errata related to a specified product family or development tool of interest.

To register, access the Microchip website at www.microchip.com, click on **Product Change Notification** and follow the registration instructions.

CUSTOMER SUPPORT

Users of Microchip products can receive assistance through several channels:

- Distributor or Representative
- Local Sales Office
- Field Application Engineer (FAE)
- Technical Support
- Development Systems Information Line

Customers should contact their distributor, representative or field application engineer (FAE) for support. Local sales offices are also available to help customers. A listing of sales offices and locations is included in the back of this document.

Technical support is available through the website at: <http://support.microchip.com>

DOCUMENT REVISION HISTORY

Revision A (September 2009)

This is the initial released revision of this document.

Revision B (August 2019)

In this revision of the document, changes are made to mention that the board is for Microchip Digital Signal Controller (DSC) devices in general, not specifically for the dsPIC33F family of devices as mentioned in the previous revision.

Minor text and formatting edits throughout document.

Revision C (September 2019)

Changed the development board part number in [Section 1.3 "What's Included"](#).

Chapter 1. Introduction

The dsPICDEM™ MCSM Development Board is targeted to control both unipolar and bipolar stepper motors with no hardware configuration changes. This flexible and cost-effective board can be configured in different ways for use with Microchip's specialized Motor Control Digital Signal Controllers (DSCs).

The dsPICDEM™ MCSM Development Board offers a mounting option to connect either a 28-pin SOIC device or a generic 100-pin Plug-In Module (PIM). The board also has two full-bridge inverters. The hardware is designed in such a way that no hardware changes are necessary for eight, six or four-wire stepper motors in either bipolar or unipolar configurations. Topics covered include:

- [Overview](#)
- [Features](#)
- [What's Included](#)
- [Reference Documents and Webinars](#)

1.1 OVERVIEW

[Figure 1-1](#) shows a photograph of the dsPICDEM™ MCSM Development Board. A dsPIC® device uses the MOSFET driver to drive the two full-bridge inverters that power the motor windings. The board includes various circuitries to perform the following functions:

- Drive two motor windings with the two on-board full-bridge inverters
- Measure feedback and other analog signals (i.e., current, DC voltage, potentiometer and Fault signals)
- Communicate with a host computer or an external device via USB

The dsPICDEM™ MCSM Development Board supports terminal voltages up to 80V and currents up to 3A. Refer to [Appendix B. "Electrical Specifications"](#) for more information.

dsPICDEM™ MCSM Development Board User's Guide

FIGURE 1-1: dsPICDEM™ MCSM DEVELOPMENT BOARD

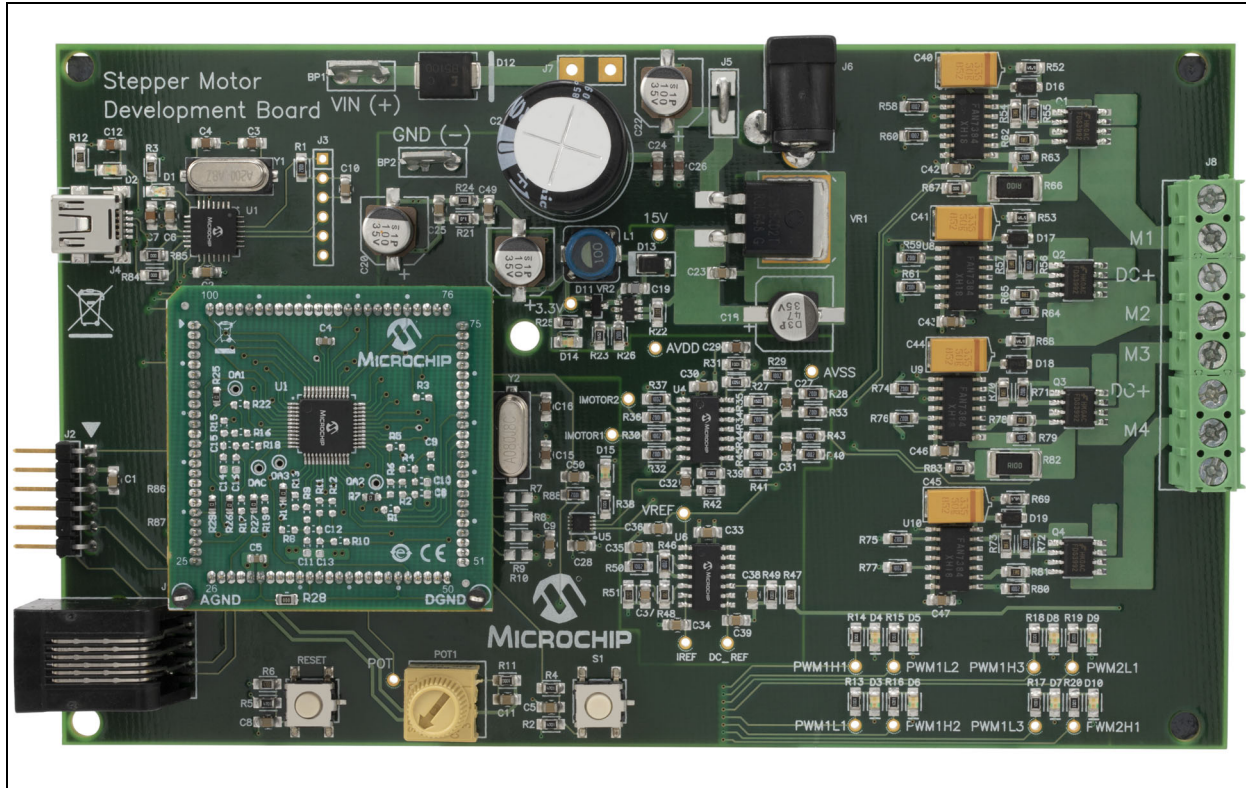

1.2 FEATURES

The key features of this board include the following:

- Motor Control PIM Device (U2) Socket:
 - The dsPIC33FJ12MC202 motor control device in SOIC package (U3) footprint
- Motor Control Interfaces:
 - Two full-bridge inverters
 - Two phase current sense resistors
 - DC bus voltage sense resistor
 - Overcurrent protection
- Input/Output Control Switches:
 - One push button (S1)
 - Reset push button (RESET)
 - 10 k Ω potentiometer (POT)
 - LED indicators for PWM outputs arranged in a full-bridge format
 - LED indicator for overcurrent
- Communication Ports:
 - UART communication via USB (J4)
- Built-In Power Supplies:
 - 15V power supply, maximum power available: 11W
 - 3.3V power supply, maximum power available: 2W
- Power Supply Connectors:
 - 24V power input connector (J6) for the controller and power stage
 - Auxiliary power tab fast on connectors (BP1 and BP2) for the power stage
- Programming Connectors:
 - ICSP™ connector for programming a dsPIC DSC device (J2)
 - RJ11 connector for programming a dsPIC DSC device (J1)
 - ICSP connector for programming the PIC18LF2450 USB-to-UART bridge (J3)

1.3 WHAT'S INCLUDED

The dsPICDEM MCSM Development Board with the part number DM330022-1 contains the following:

- dsPICDEM MCSM Development Board
- dsPIC33CK64MP105 External Op Amp Motor Control Plug-In-Module (P/N: MA330050-1)
- USB to Mini-USB cable
- Screwdriver

1.4 REFERENCE DOCUMENTS AND WEBINARS

In addition to the documents listed in the “[Recommended Reading](#)” section, the following are also available from Microchip to support the use of the dsPICDEM™ MCSM Development Board.

- AN907 “*Stepping Motors Fundamentals*”
- AN906 “*Stepper Motor Control Using the PIC16F684*”
- AN822 “*Stepper Motor Microstepping with PIC18C452*”
- Stepper motor webinars are available at:
<http://techtrain.microchip.com/webseminars/Archived.aspx>
 - Stepper Motors Part 1: Types of Stepper Motors
 - Stepper Motors Part 2: Stepper Motor Control

You can obtain these reference documents from your nearest Microchip sales office (listed in the last page of this document) or by downloading them from the Microchip website.

Chapter 2. Getting Started

This chapter describes how to set up the dsPICDEM™ MCSM Development Board hardware and software; and how to run the included demonstration software. Refer to [Chapter 3. “Hardware”](#) for detailed information on the board and its components.

Topics in this chapter include:

- [Board Setup](#)
- [Programming and Debugging Application Code](#)

2.1 BOARD SETUP

WARNING

The dsPICDEM™ MCSM Development Board is intended to drive bipolar or unipolar stepper motors. Before connecting the motor, make sure that the power rating of the motor is equal to or less than the power rating of the board, as shown in [Appendix B. “Electrical Specifications”](#). Also, make sure the configuration resistors are correct for the firmware and the specific dsPIC® DSC device mounted on the socket. Failure to comply with this warning could lead to malfunction of the board and the motor, and could result in physical harm.

Before beginning the start-up procedure, complete a visual check of the board and the motor for connectivity and mechanical damage. If damage is found, DO NOT power up the board; otherwise, you may further damage the equipment. Contact Microchip’s local office or distributor immediately.

The following procedure describes how to set up the dsPICDEM™ MCSM Development Board to run with the demonstration software. The stepper motor used for the demonstration is the Leadshine Stepping Motor (P/N 42HS03). This can be ordered from the Microchip web site as part number AC300024.

1. Place the dsPICDEM™ MCSM Development Board on a sturdy insulated platform.
2. Make sure that the dsPIC33CK64MP105 PIM or an appropriate PIM is mounted in the socket.
3. Connect the stepper motor (Leadshine part # 42HS03 or a substitute stepper motor) to J8. Connect the motor phases in a bipolar series connection as described in [Table 2-1](#).

TABLE 2-1: MOTOR CONFIGURATION TABLE

J8 Pin Number	J8 Pin Name	Bipolar Series	Bipolar Parallel	Bipolar Half-winding	Unipolar
1	NC	Green + Yellow	—	Yellow	—
2	M1	Black	Black + Yellow	Black	Black
3	DC+	—	—	Orange	Green + Yellow
4	M2	Orange	Green + Orange	Green	Orange
5	M3	Red	Red + White	Red	Red
6	DC+	—	—	White	Blue + White
7	M4	Brown	Blue + Brown	Blue	Brown
8	NC	Blue + White	—	Brown	—

dsPICDEM™ MCSM Development Board User's Guide

4. Connect the 24V power supply to J6. A power supply can be ordered from the Microchip website as part number AC002013, or substitute any power adapter compatible with the Phihong model PSAC60W-240 (24 volts, 2.5 amps, with a center positive barrel DC output connector).
5. Press S1 to run the motor.
6. Vary the motor's speed with the potentiometer.
7. Press S1 to switch to Full-Step Wave mode, Full-Step, Half-Step and Various Microstepping modes. Pushing S1 after the 256th microstep step setting stops the motor. Press S1 again to repeat the cycle.

Operating the dsPICDEM™ MCSM Development Board using the on-board POT and switch button cannot offer the flexibility required in most applications and it is only intended as a quick start demonstration. To have more control over the motor using a real-time communication tool, please refer to the next section.

2.2 PROGRAMMING AND DEBUGGING APPLICATION CODE

The following procedure describes how to program the dsPICDEM™ MCSM Development Board in Debug mode:

1. Place the dsPICDEM™ MCSM Development Board on a sturdy insulated platform.
2. Make sure that the dsPIC33CK64MP105 PIM or an appropriate PIM is mounted in the socket.
3. Connect the stepper motor (Leadshine part #42HS03 or a substitute stepper motor) to J8. Connect motor phases in a bipolar series connection as described in [Table 2-1](#).
4. Connect the 24V power supply to J6. A power supply can be ordered from the Microchip website as part number AC002013, or substitute any power adapter compatible with the Phihong model PSAC60W-240 (24 volts, 2.5 amps, with a center positive barrel DC output connector).
5. Connect PICKit™ 3 or PICKit 4 In-Circuit Debugger/Programmer, MPLAB® ICD 3 or ICD 4, or MPLAB REAL ICE™ In-Circuit Emulator to the computer and to the board at J1 or J2.
6. Connect the USB cable to J4 and to the computer.
7. Download the stepper motor (AN1307) code for the dsPIC33CK64MP105 from the Microchip web site for the MCSM at www.microchip.com/mcsm.
8. Build the project and download the program into the processor.
9. Click the **Run** icon when in Debug mode.

Note: For more information on running stepper motors, refer to [Section 1.4 "Reference Documents and Webinars"](#).

Chapter 3. Hardware

This chapter describes the hardware used in the dsPICDEM™ MCSM Development Board. Topics covered include:

- [Hardware Architecture](#)
- [Board Connectors](#)
- [User Interface Hardware](#)

3.1 HARDWARE ARCHITECTURE

The dsPIC DSC® devices feature an 8-channel, high-speed PWM with Complementary mode output, a programmable ADC trigger on the PWM reload cycle, digital dead-time control, internal shoot-through protection and hardware Fault shutdown.

These features make the dsPIC DSC an ideal solution for high-performance stepper motor control applications where full control of the full-bridge inverter is required.

[Figure 3-1](#) provides a simplified block diagram of the development board hardware.

FIGURE 3-1: dsPICDEM™ MCSM DEVELOPMENT BOARD BLOCK DIAGRAM

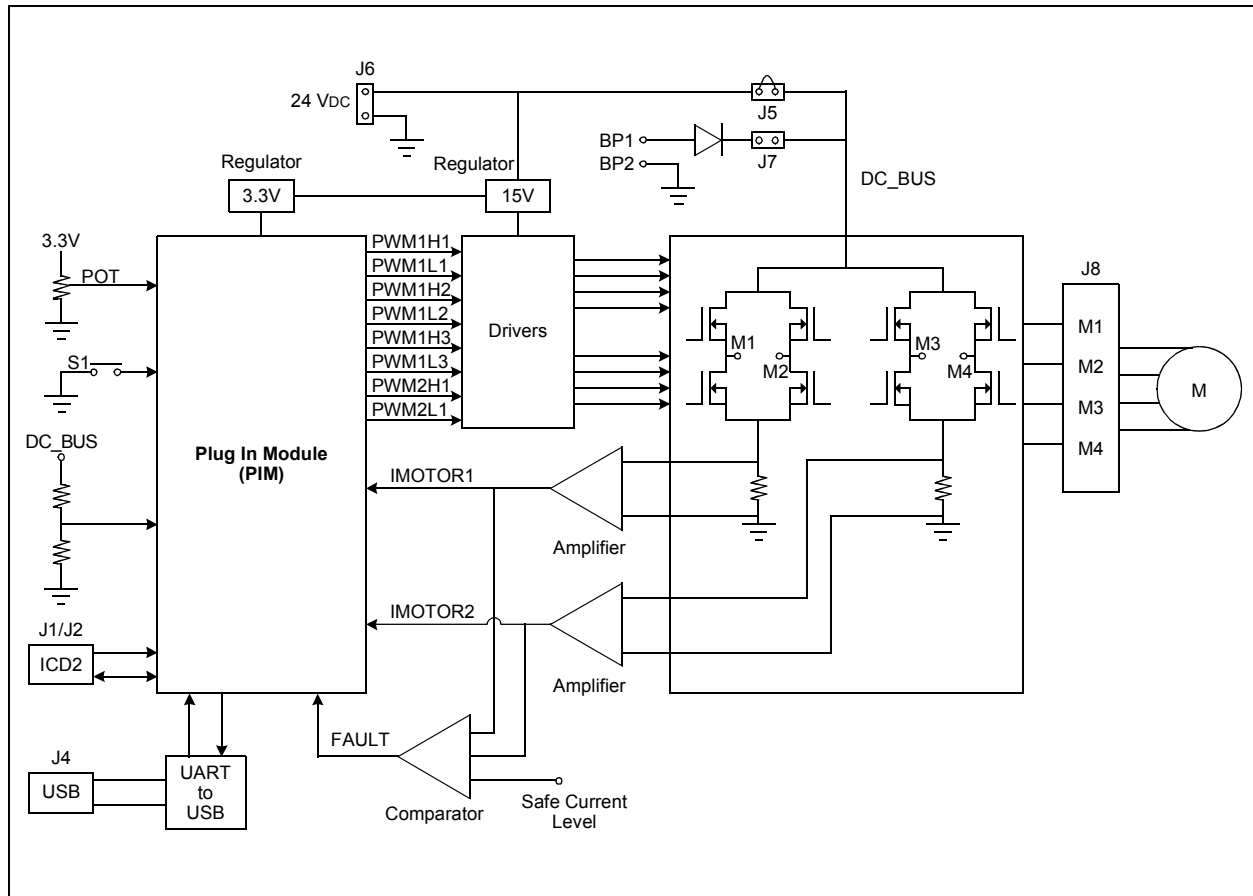

dsPICDEM™ MCSM Development Board User's Guide

3.1.1 PIM Header

The dsPICDEM™ MCSM Development Board has been designed to accommodate detachable Plug-in Modules (PIMs). The board supports 100-pin PIMs. The PIM pinout and function on the dsPICDEM™ MCSM Development Board are provided in [Table 3-2](#).

TABLE 3-1: PIM PIN DESCRIPTION

PIM Pin Number	Signal Name	Pinout Description
1	—	N/A
2	VDD	Digital Supply
3	PWM1H3	PWM Output
4	PWM2L1	PWM Output
5	PWM2H1	PWM Output
6	—	N/A
7	—	N/A
8	—	N/A
9	—	N/A
10	—	N/A
11	—	N/A
12	—	N/A
13	{MCLR}	Device Master Clear
14	—	N/A
15	VSS	Digital Supply Ground
16	VDD	Digital Supply
17	—	N/A
18	PWM2H1	PWM Output
19	PWM2L1	PWM Output
20	POT	Potentiometer Signal
21	—	N/A
22	POT	Potentiometer Signal
23	DC_REF	DC Bus Voltage (downscaled)
24	IMOTOR2	Phase 1 Current Signal
25	IMOTOR1	Phase 2 Current Signal
26	PGC	Device Programming Clock Line
27	PGD	Device Programming Data Line
28	—	N/A
29	—	N/A
30	AVDD	Analog Supply
31	AVSS	Analog Supply Ground
32	—	N/A
33	—	N/A
34	—	N/A
35	DC_REF	DC Bus Voltage (downscaled)
36	VSS	Digital Supply Ground
37	VDD	Digital Supply
38	—	N/A
39	—	N/A
40	—	N/A

TABLE 3-1: PIM PIN DESCRIPTION (CONTINUED)

PIM Pin Number	Signal Name	Pinout Description
41	POT	Potentiometer Signal
42	—	N/A
43	—	N/A
44	—	N/A
45	Vss	Digital Supply Ground
46	VDD	Digital Supply
47	—	N/A
48	—	N/A
49	USB_RX	UART Receive
50	USB_TX	UART Transmit
51	USB_TX	UART Transmit
52	USB_RX	UART Receive
53	—	N/A
54	USB_VBUS	USB VBUS
55	USB_3.3V	N/A
56	USB_D-	USB Data -
57	USB_D+	USB Data +
58	—	N/A
59	—	N/A
60	—	N/A
61	—	N/A
62	VDD	Digital Supply
63	OSCI	Crystal Oscillator In
64	OSCO	Crystal Oscillator Out
65	Vss	Digital Supply Ground
66	—	N/A
67	—	N/A
68	FAULT_1	Fault Signal
69	—	N/A
70	BTN_1	Push Button S1 Input
71	—	N/A
72	—	N/A
73	—	N/A
74	—	N/A
75	Vss	Digital Supply Ground
76	USB_TX	UART Transmit
77	PWM2H1	PWM Output
78	PWM2L1	PWM Output
79	—	N/A
80	—	N/A
81	—	N/A
82	—	N/A
83	USB_TX	UART Transmit
84	USB_RX	UART Receive
85	—	N/A

TABLE 3-1: PIM PIN DESCRIPTION (CONTINUED)

PIM Pin Number	Signal Name	Pinout Description
86	VDD	Digital Supply
87	—	N/A
88	—	N/A
89	—	N/A
90	—	N/A
91	—	N/A
92	—	N/A
93	PWM1L1	PWM Output
94	PWM1H1	PWM Output
95	—	N/A
96	—	N/A
97	—	N/A
98	PWM1L2	PWM Output
99	PWM1H2	PWM Output
100	PWM1L3	PWM Output

PIM Pin 19 can be configured for FAULT_1 or PWM2L1 signals by soldering the appropriate resistor as follows:

- For FAULT_1: Remove R87 and solder R86
- For PWM2L1: Remove R86 and solder R87 (default)

Note 1: The “dsPIC33CK64MP105 Motor Control Plug-In Module (PIM) Information Sheet for External Op Amp Configuration” is available from either the PIM website: <https://new.microchipdirect.com/product/search/all/MA330050-1> or else from the Microchip website (www.microchip.com/DS50002848).

2: Refer to www.microchip.com/mcsm for compatible PIMs released in the future and their PIM information sheets.

3.1.2 Power Stage

The dsPICDEM™ MCSM Development Board features two full-bridge inverters to accommodate a bipolar stepper motor. The full-bridge inverters can be powered from a supply of up to 80V.

3.1.2.1 MOSFET DRIVER

Although the dsPIC DSC devices can operate in Complementary PWM mode, Independent PWM mode is still possible. In this case, internal dead-time control and shoot-through protection circuits are disabled. In order to protect the power stage from high shoot-through currents in Independent PWM mode, the chosen MOSFET driver also has a built-in shoot-through protection and a small fixed dead time. In Independent PWM mode, the development board is suitable for controlling two Brushed DC motors with full direction control, or up to four DC motors with a single turning direction.

3.1.2.2 SWITCHING TOPOLOGY

Driving a stepper motor in a full-bridge topology requires switching the opposite diagonal MOSFETs on and off, at the same time, in order to reverse the drive current and to accommodate all possible Decay modes. Since all PWMxHx pins are on at the same time (for example, PWM1H1 and PWM1H2), it is not possible to drive all of the high-side MOSFETs with the PWMxHx signals. [Figure 3-2](#) shows the PWM and MOSFET assignment.

Driving the high PWM pins active will run the current through a motor winding in one direction, while driving the low PWM pins active will run the current through the winding in the opposite direction. By using this topology, in addition to the dsPIC PWM override feature, all Decay modes for the winding current can be achieved.

Refer to [Appendix A. "Board Layout and Schematics"](#) for the complete schematic and PWM pin assignments.

FIGURE 3-2: MOSFET PWM ASSIGNMENT

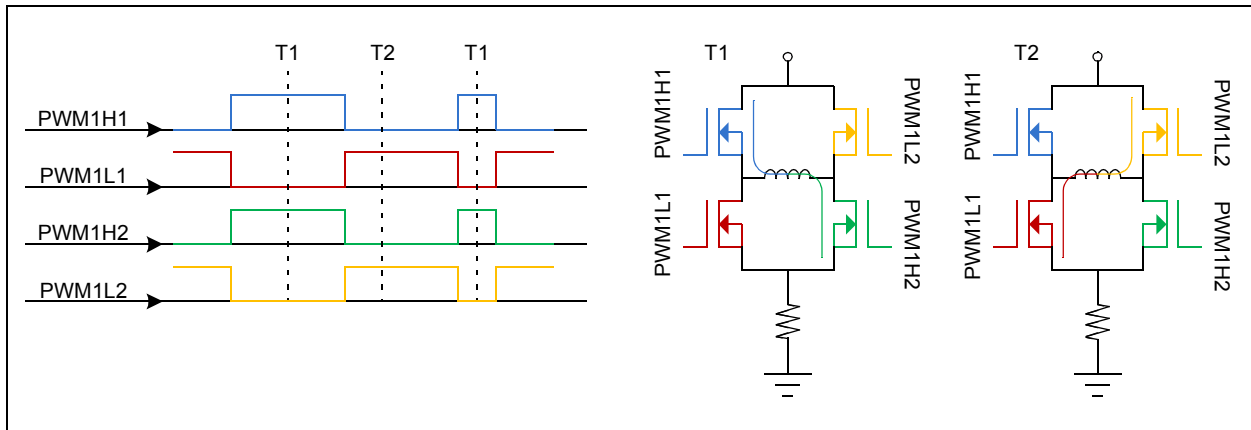

3.1.3 Current Sensing

Two shunt resistors are available for current sensing, one for each of the two motor windings. In order to read both positive and negative currents, the amplifier circuit is designed with an offset of $V_{REF} = AV_{DD}/2$. The amplifier gain allows for a maximum current range of $\pm 2.2A$.

To calculate the amplifier gain, use the formula provided in [Equation 3-1](#):

EQUATION 3-1: AMPLIFIER GAIN CALCULATION FORMULA

$$Gain = R_{SHUNT} \cdot \frac{R_{27}}{R_{28} + R_{29}}$$

Note: The default gain value is 0.75 V/A, allowing a resolution of 4.3 mA/count with a 10-bit ADC.

The formula shown in [Equation 3-1](#) is a simplified version of the complete formula and is only valid when $R_{28} = R_{29} = R_{33} = R_{34}$ and $R_{27} = R_{35}$. If changes to the amplifier gain are needed, use the above formula to calculate R_{27} corresponding to the desired gain, and then replace both R_{27} and R_{35} with the calculated resistor value. Make the same changes for R_{39} and R_{45} .

The DC voltage supplied to the power stage is measured with a simple resistor divider. To calculate the DC_REF signal used for this purpose, use the formula provided in [Equation 3-2](#):

EQUATION 3-2: DC_REF SIGNAL CALCULATION FORMULA

$$DC_REF = \frac{1}{28} DC_BUS$$

3.1.4 Fault Protection

The dsPICDEM™ MCSM Development Board features an overcurrent Fault detection, which triggers a PWM shutdown. Each phase current is amplified and then compared with a fixed “safe” current value. A value of 1.7A is set for the dsPICDEM™ MCSM Development Board; however, the user can change this limit by changing the resistor divider made by R48 and R51. When either of the two phase currents is above the “safe” current level, a Fault signal is triggered and the dsPIC DSC hardware module automatically switches off all PWM outputs.

The Fault LED (D15) is active only when an overcurrent is present in the motor windings. It will go inactive immediately after the internal dsPIC Fault circuit shuts down the PWM pins. In this case, the LED will not be visible as the on time is very short. The Fault LED will only be visible if the Fault is persistent, that is when the software Fault shutdown is disabled.

WARNING

If the Fault LED is permanently active, power off the board immediately to avoid damage to the power MOSFETs.

3.2 BOARD CONNECTORS

Figure 3-3 shows the various user interface components available on the dsPICDEM™ MCSM Development Board. Table 3-2 describes the hardware connection between the PICKIT™ 3, PICKIT 4, MPLAB® ICD 3 or ICD 4, or MPLAB REAL ICE™ In-Circuit Emulator, the power supply, and the dsPICDEM™ MCSM Development Board connectors.

FIGURE 3-3: dsPICDEM™ MCSM DEVELOPMENT BOARD USER INTERFACE COMPONENTS

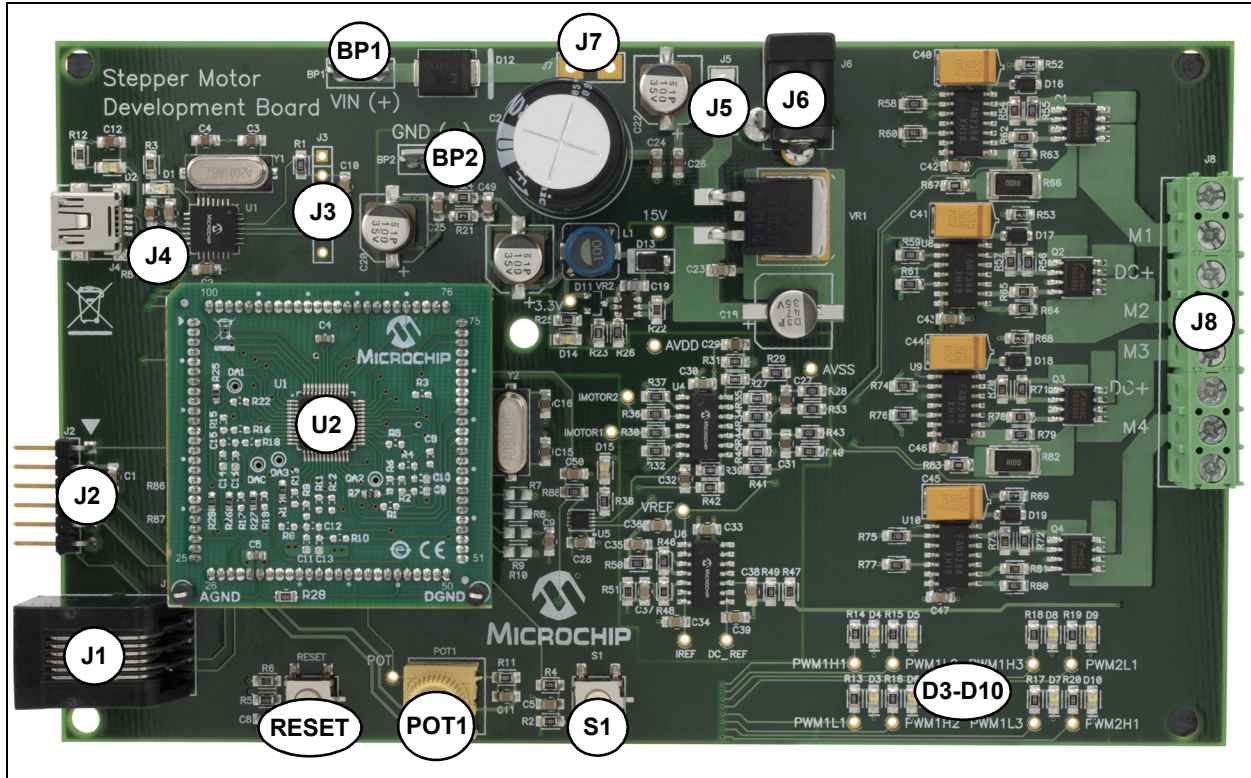

TABLE 3-2: dsPICDEM™ MCSM DEVELOPMENT BOARD USER INTERFACE COMPONENTS

Designator	Description
BP1-BP2	Auxiliary Power Supply Connector
D3-D10	PWM LEDs
S1	Push Button Switch 1
RESET	Device Reset Switch
POT1	Potentiometer
U2	Plug-In Module (PIM) Adapter
J1	RJ11, 6-Pin Connector for Programming a dsPIC® DSC Device
J2	ICSP™ Connector for Programming a dsPIC DSC Device
J3	ICSP Programmer Interface Connector for Programming the PIC18LF2450 USB-to-UART Bridge
J4	USB Interface Port
J5	24V Power Supply Select Jumper
J6	24V Input Power Supply Connector
J7	Auxiliary Power Supply Select Jumper
J8	Motor Power Connector

3.2.1 Input Power Connector (J6, BP1-BP2)

The dsPICDEM™ MCSM Development Board receives the power for control circuits from a +24V power supply. The 24V supply is always needed as it supplies the necessary 15V and 3.3V for the dsPIC DSC, and for the interface between the dsPIC DSC and the power stage. The power stage DC bus voltage can be connected to the development board through the J6 or BP1-BP2 connectors.

3.2.2 DC Bus Power Supply Connector (J5 and J7)

By default, jumper J5 is short and jumper J7 is open, and the +24V input power supply connected to J6 supplies both the control circuits and the DC bus voltage to the development board. If jumper J7 is short and jumper J5 is open, the BP1-BP2 connectors supply the DC bus voltage to the development board power stage and J6 supplies the control circuits.

The 0V-80V DC power supply can be connected between BP1-BP2.

3.2.3 USB Interface (J4)

The development board uses an on-board PIC18 interface as a bridge between the UART and the USB. The PIC18 UART pins are connected to the dsPIC devices on different ports depending on the specific dsPIC device used. For the specific devices that do not have remappable peripherals, additional UART RX/TX pins are available on the device-designated port for UART communication.

For dsPIC DSC devices that have an embedded USB port, populate R7, R8, R9 and R10 with 0Ω resistors, and disable the PIC18 USB communication by removing R84 and R85.

3.2.4 ICSP Connector for dsPIC DSC (J1/J2)

The MPLAB® ICD 3 and MPLAB REAL ICE™ connector is an RJ11 female connector (J1) that connects the MPLAB ICD 3, ICD 4 or MPLAB REAL ICE In-Circuit Debugger to the dsPIC device for programming and debugging purposes. The PICkit™ 3 or PICkit 4 In-Circuit Debugger/Programmer can be connected to the board using a 6-pin ICSP connector (J2).

3.2.5 ICSP for PIC18 (J3)

J3 is a 6-pin connector that connects the PICkit 3 In-Circuit Debugger/Programmer to the PIC18 device. The development board uses the on-board PIC18 interface as a bridge between the UART and USB. The PIC18 can be programmed for USB communication.

3.2.6 Motor Connector (J8)

The motor connector has eight terminals. [Table 3-3](#) lists the functionality of each terminal.

TABLE 3-3: MOTOR CONNECTOR DETAILS

Terminal Number	Designator	Description
1	N/C	Not Connected
2	M1	Motor Wire 1 (Phase 1)
3	DC+	DC Bus Voltage
4	M2	Motor Wire 2 (Phase 1)
5	M3	Motor Wire 3 (Phase 2)
6	DC+	DC Bus Voltage
7	M4	Motor Wire 4 (Phase 2)
8	N/C	Not Connected

The connector is configured in such a way so that all eight motor wires can be connected in all possible configurations. Considering an eight-wire motor in a bipolar configuration (series or half-winding), two wires will be left floating. The N/C pins are available to accommodate the two floating wires.

The DC bus connection is placed between wires of two different phases to accommodate the center tap of a winding in unipolar configurations. Refer to [Table 3-3](#) for details on how to connect the motor wires to J8 for all possible configurations.

3.2.7 Test Points

[Table 3-4](#) lists the test points that can be used to check various signals.

TABLE 3-4: TEST POINTS

Test Points	Description
POT	POT Signal
15V	15V MOSFET Driver Supply
3.3V	3.3V Digital Supply
AVDD	Analog Supply (3.3V)
AVSS	Analog Ground
IMOTOR1	Motor Current Phase 1
IMOTOR2	Motor Current Phase 2
VREF	Zero Current Reference Voltage
DC_REF	DC_BUS Voltage Input to ADC
IREF	Reference Current for Fault Detection
PWM1H1	PWM Output for Wire 1 Top Switch
PWM1L1	PWM Output for Wire 1 Bottom Switch
PWM1H2	PWM Output for Wire 2 Bottom Switch
PWM1L2	PWM Output for Wire 2 Top Switch
PWM1H3	PWM Output for Wire 3 Top Switch
PWM1L3	PWM Output for Wire 3 Bottom Switch
PWM2H1	PWM Output for Wire 4 Bottom Switch
PWM2L1	PWM Output for Wire 4 Top Switch

dsPICDEM™ MCSM Development Board User's Guide

3.3 USER INTERFACE HARDWARE

The dsPICDEM™ MCSM Development Board consists of the following push buttons, LEDs and potentiometers:

- One Push Button
- One Potentiometer
- Eight PWM LEDs
- One Power-on Status LED
- Two USB LEDs
- One Fault LED
- Device Reset Push Button

TABLE 3-5: INDICATORS AND HUMAN INTERFACES

Label	Hardware Element Description
S1	Push button; this push button is connected to a port pin. When momentarily pressed, the switch connects the respective port pin to Ground.
POT1	10 k Ω potentiometer; it is connected to the analog input pin.
RESET	Push button; this push button, when pressed, causes a device Reset.
D1	USB communication indicator, which indicates the device has been detected.
D2	USB bus indicator, which indicates that the device is connected to the USB bus.
D3-D10	LEDs, which indicate the PWM pin status. When an LED is on, the respective PWM pin is high.
D14	Power-on status LED, which indicates the status of the +3.3V regulator.
D15	Fault LED; indicates an overcurrent.

Appendix A. Board Layout and Schematics

FIGURE A-1: dsPICDEM™ MCSM DEVELOPMENT BOARD LAYOUT (TOP)

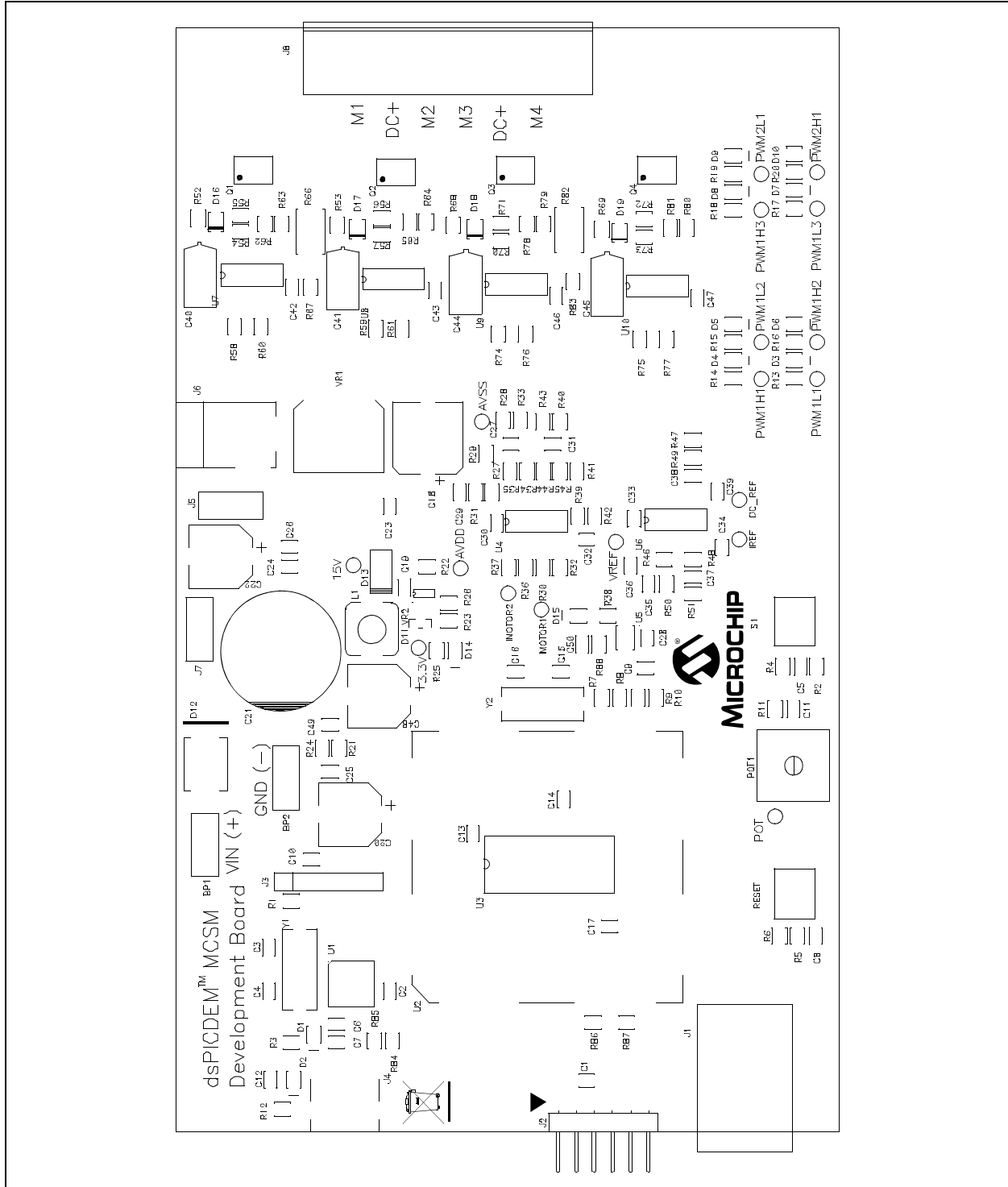

dsPICDEM™ MCSM Development Board User's Guide

FIGURE A-2: dsPICDEM™ MCSM DEVELOPMENT BOARD SCHEMATIC (SHEET 1 OF 4)

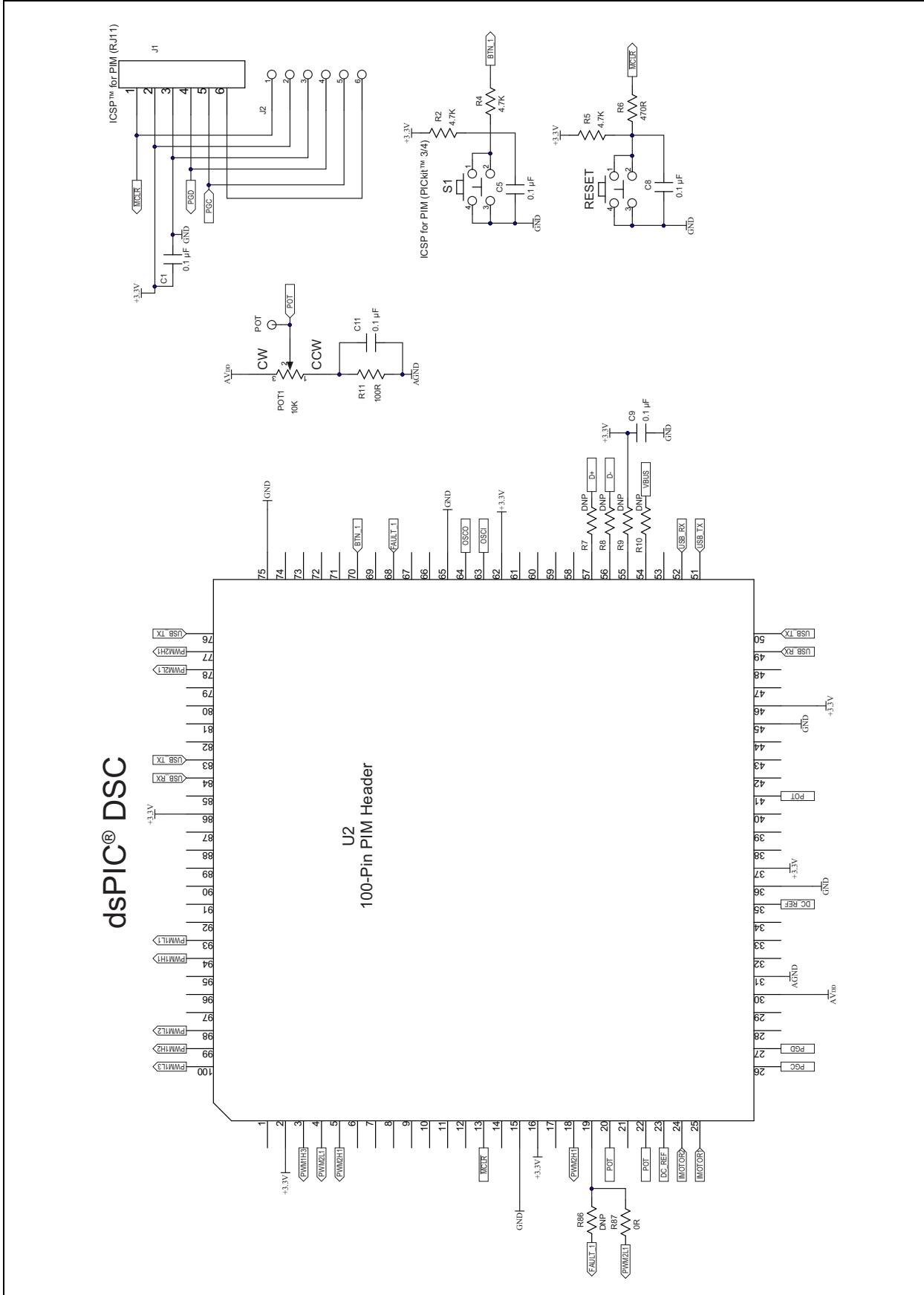
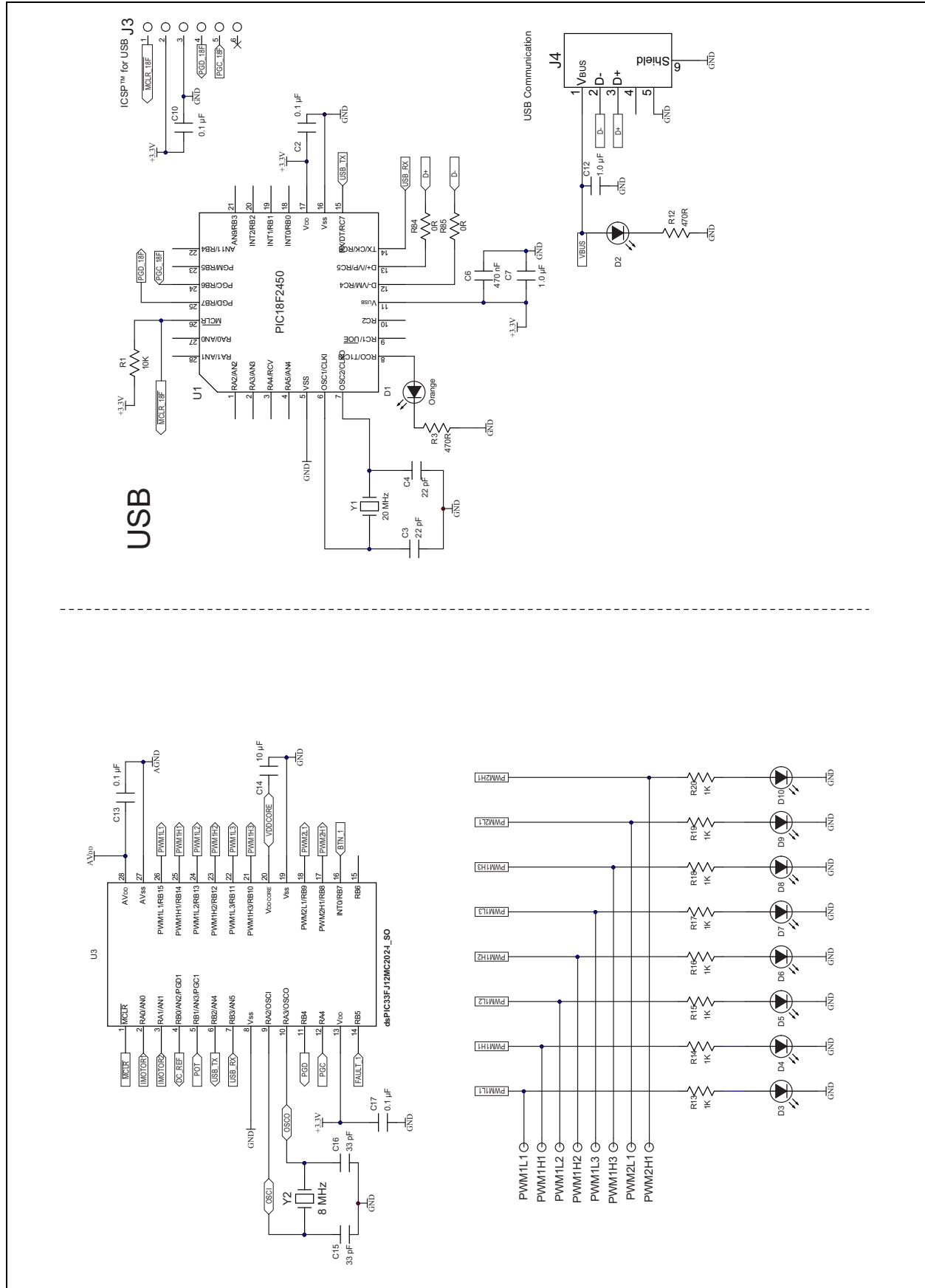

FIGURE A-3: dsPICDEM™ MCSM DEVELOPMENT BOARD SCHEMATIC (SHEET 2 OF 4)



dsPICDEM™ MCSM Development Board User's Guide

FIGURE A-4: dsPICDEM™ MCSM DEVELOPMENT BOARD SCHEMATIC (SHEET 3 OF 4)

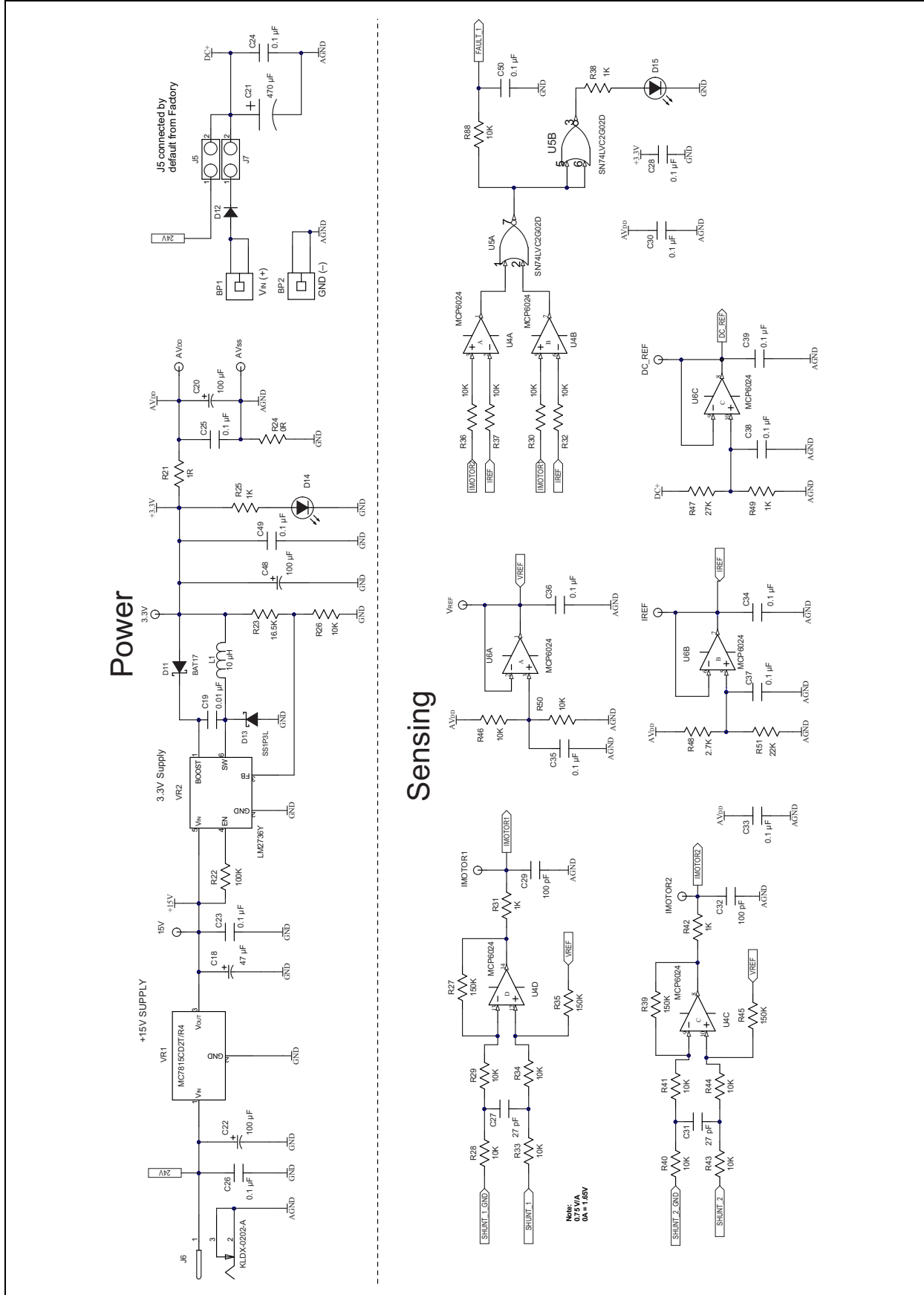
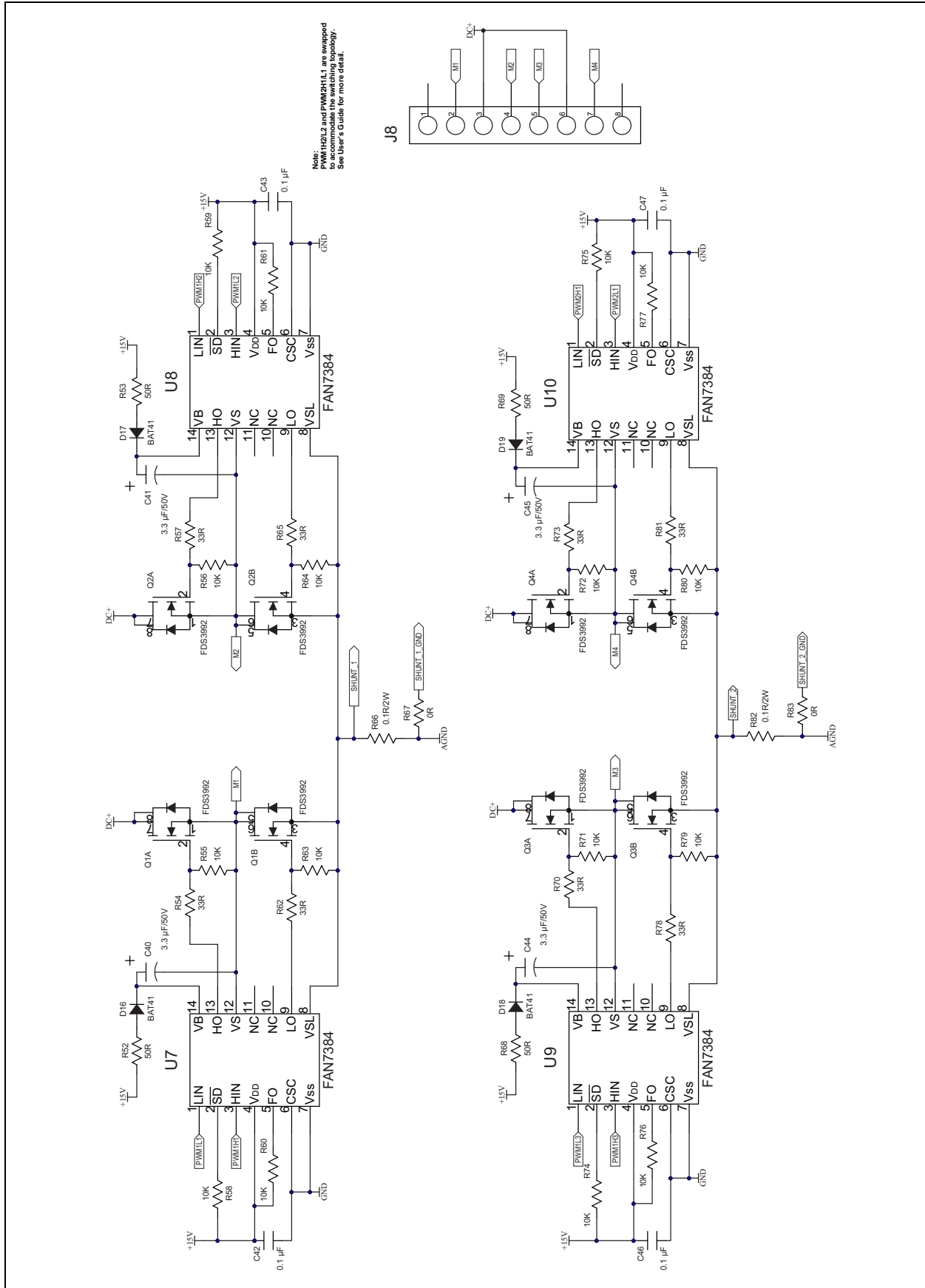

FIGURE A-5: dsPICDEM™ MCSM DEVELOPMENT BOARD SCHEMATIC (SHEET 4 OF 4)



dsPICDEM™ MCSM Development Board User's Guide

NOTES:



Appendix B. Electrical Specifications

This appendix provides important electrical specifications for the dsPICDEM™ MCSM Development Board.

TABLE B-1: DC INPUT RATING

Parameter	Condition	Min	Typ	Max	Unit
Power Supply Connected to J6	—	18	24	35	VDC
Power Supply Connected to BP1-BP2	J5 open, J7 closed	0	24	80	VDC

TABLE B-2: DC OUTPUT RATING (J8)

Parameter	Condition	Min	Typ	Max	Unit
Voltage	J5 closed, J7 open	0	24	24	VDC
	J5 open, J7 closed	0	24	80	
Peak Current	—	0	1	3.5	A
Power Rating	—	0	9 ⁽¹⁾	40 ^(2,3)	W

Note 1: While driving two phases on, at 1A each, through a 4.6Ω winding resistance.

2: Maximum power tested is 40W.

3: Maximum theoretical power with no additional heat sink is: 80V * 1.7A = 135W.

dsPICDEM™ MCSM Development Board User's Guide

NOTES:



dsPICDEM™ MCSM DEVELOPMENT BOARD USER'S GUIDE

Index

A		M	
Amplifier Gain Calculation Formula.....	20	Microchip Internet Website.....	8
B		MOSFET PWM Assignment.....	19
Block Diagram.....	10	Motor Configuration.....	13
Board Layout.....	25	Motor Connector (J8).....	22
C		P	
Connectors and Jumpers.....	21	Plug-In Module (PIM).....	9
Current Sensing.....	20	Power Stage.....	18
Customer Support.....	8	MOSFET Driver.....	18
D		Switching Topology.....	19
DC Bus Power Supply Connector (J5 and J7).....	22	R	
DC_REF Signal Calculation Formula.....	20	Reading, Recommended.....	7
Documentation		S	
Conventions.....	6	Schematics	
Layout.....	5	Sheet 1 of 4.....	26
F		Sheet 2 of 4.....	27
Fault LED (D15).....	20	Sheet 3 of 4.....	28
Fault Protection.....	20	Sheet 4 of 4.....	29
I		Signal Test Points.....	23
ICSP Connector for dsPIC DSC (J1/J2).....	22	Stepper Motors	
ICSP for PIC18 (J3).....	22	Bipolar.....	9
Indicators and Human Interfaces.....	24	Unipolar.....	9
Input Power Connector (J6, BP1-BP2).....	22	U	
Internet Address.....	8	USB Interface (J4).....	22
K		User Interface Hardware.....	24
Key Features.....	11	W	
Kit Contents.....	11	WWW Address.....	8



MICROCHIP

Worldwide Sales and Service

AMERICAS

Corporate Office
2355 West Chandler Blvd.
Chandler, AZ 85224-6199
Tel: 480-792-7200
Fax: 480-792-7277
Technical Support:
<http://www.microchip.com/support>
Web Address:
www.microchip.com

Atlanta

Duluth, GA
Tel: 678-957-9614
Fax: 678-957-1455

Austin, TX

Tel: 512-257-3370

Boston

Westborough, MA
Tel: 774-760-0087
Fax: 774-760-0088

Chicago

Itasca, IL
Tel: 630-285-0071
Fax: 630-285-0075

Dallas

Addison, TX
Tel: 972-818-7423
Fax: 972-818-2924

Detroit

Novi, MI
Tel: 248-848-4000

Houston, TX

Tel: 281-894-5983

Indianapolis

Noblesville, IN
Tel: 317-773-8323
Fax: 317-773-5453
Tel: 317-536-2380

Los Angeles

Mission Viejo, CA
Tel: 949-462-9523
Fax: 949-462-9608
Tel: 951-273-7800

Raleigh, NC

Tel: 919-844-7510

New York, NY

Tel: 631-435-6000

San Jose, CA

Tel: 408-735-9110
Tel: 408-436-4270

Canada - Toronto

Tel: 905-695-1980
Fax: 905-695-2078

ASIA/PACIFIC

Australia - Sydney
Tel: 61-2-9868-6733

China - Beijing
Tel: 86-10-8569-7000

China - Chengdu
Tel: 86-28-8665-5511

China - Chongqing
Tel: 86-23-8980-9588

China - Dongguan
Tel: 86-769-8702-9880

China - Guangzhou
Tel: 86-20-8755-8029

China - Hangzhou
Tel: 86-571-8792-8115

China - Hong Kong SAR
Tel: 852-2943-5100

China - Nanjing
Tel: 86-25-8473-2460

China - Qingdao
Tel: 86-532-8502-7355

China - Shanghai
Tel: 86-21-3326-8000

China - Shenyang
Tel: 86-24-2334-2829

China - Shenzhen
Tel: 86-755-8864-2200

China - Suzhou
Tel: 86-186-6233-1526

China - Wuhan
Tel: 86-27-5980-5300

China - Xian
Tel: 86-29-8833-7252

China - Xiamen
Tel: 86-592-2388138

China - Zhuhai
Tel: 86-756-3210040

ASIA/PACIFIC

India - Bangalore
Tel: 91-80-3090-4444

India - New Delhi
Tel: 91-11-4160-8631

India - Pune
Tel: 91-20-4121-0141

Japan - Osaka
Tel: 81-6-6152-7160

Japan - Tokyo
Tel: 81-3-6880-3770

Korea - Daegu
Tel: 82-53-744-4301

Korea - Seoul
Tel: 82-2-554-7200

Malaysia - Kuala Lumpur
Tel: 60-3-7651-7906

Malaysia - Penang
Tel: 60-4-227-8870

Philippines - Manila
Tel: 63-2-634-9065

Singapore
Tel: 65-6334-8870

Taiwan - Hsin Chu
Tel: 886-3-577-8366

Taiwan - Kaohsiung
Tel: 886-7-213-7830

Taiwan - Taipei
Tel: 886-2-2508-8600

Thailand - Bangkok
Tel: 66-2-694-1351

Vietnam - Ho Chi Minh
Tel: 84-28-5448-2100

EUROPE

Austria - Wels
Tel: 43-7242-2244-39
Fax: 43-7242-2244-393

Denmark - Copenhagen
Tel: 45-4450-2828
Fax: 45-4485-2829

Finland - Espoo
Tel: 358-9-4520-820

France - Paris
Tel: 33-1-69-53-63-20
Fax: 33-1-69-30-90-79

Germany - Garching
Tel: 49-8931-9700

Germany - Haan
Tel: 49-2129-3766400

Germany - Heilbronn
Tel: 49-7131-72400

Germany - Karlsruhe
Tel: 49-721-625370

Germany - Munich
Tel: 49-89-627-144-0
Fax: 49-89-627-144-44

Germany - Rosenheim
Tel: 49-8031-354-560

Israel - Ra'anana
Tel: 972-9-744-7705

Italy - Milan
Tel: 39-0331-742611
Fax: 39-0331-466781

Italy - Padova
Tel: 39-049-7625286

Netherlands - Drunen
Tel: 31-416-690399
Fax: 31-416-690340

Norway - Trondheim
Tel: 47-7288-4388

Poland - Warsaw
Tel: 48-22-3325737

Romania - Bucharest
Tel: 40-21-407-87-50

Spain - Madrid
Tel: 34-91-708-08-90
Fax: 34-91-708-08-91

Sweden - Gothenberg
Tel: 46-31-704-60-40

Sweden - Stockholm
Tel: 46-8-5090-4654

UK - Wokingham
Tel: 44-118-921-5800
Fax: 44-118-921-5820