

## Surge protection plug - TTC-6P-3-HF-24DC-I-P - 2907847

Please be informed that the data shown in this PDF Document is generated from our Online Catalog. Please find the complete data in the user's documentation. Our General Terms of Use for Downloads are valid (<http://phoenixcontact.com/download>)



Surge protection plug with integrated status indicator on the module for three signal wires. For HF applications. Nominal voltage: 24 V DC



### Key Commercial Data

Packing unit	1 pc
GTIN	 4 055626 634753
GTIN	4055626634753
Weight per Piece (excluding packing)	9.300 g
Custom tariff number	85363010
Country of origin	Germany
Note	Made to Order (non-returnable)

### Technical data

#### Dimensions

Height	39 mm
Width	6.2 mm +0.1 mm
Depth	60.3 mm

#### Ambient conditions

Ambient temperature (operation)	-40 °C ... 85 °C
Ambient temperature (storage/transport)	-40 °C ... 85 °C
Permissible humidity (operation)	5 % ... 95 %
Altitude	≤ 4000 m (amsl (above mean sea level))
Degree of protection	IP20

#### General

Housing material	PBT
------------------	-----

## Surge protection plug - TTC-6P-3-HF-24DC-I-P - 2907847

### Technical data

#### General

Flammability rating according to UL 94	V-0
Color	light grey RAL 7035
Mounting type	on base element
Type	Male

#### Protective circuit

Nominal voltage $U_N$	24 V DC
Maximum continuous voltage $U_C$	30 V DC
Rated current	600 mA (56 °C)

#### Connection data

Connection method	pluggable
-------------------	-----------

#### Standards and Regulations

Standards/specifications	EN 61643-21 2001 + A1:2009 + A2:2013
	IEC 61643-21 2000 + corrigendum 2001 + A1:2008, modified + A2:2012

#### Environmental Product Compliance

	Lead 7439-92-1
China RoHS	Environmentally Friendly Use Period = 50
	For details about hazardous substances go to tab "Downloads", Category "Manufacturer's declaration"

### Drawings

# Surge protection plug - TTC-6P-3-HF-24DC-I-P - 2907847

Dimensional drawing

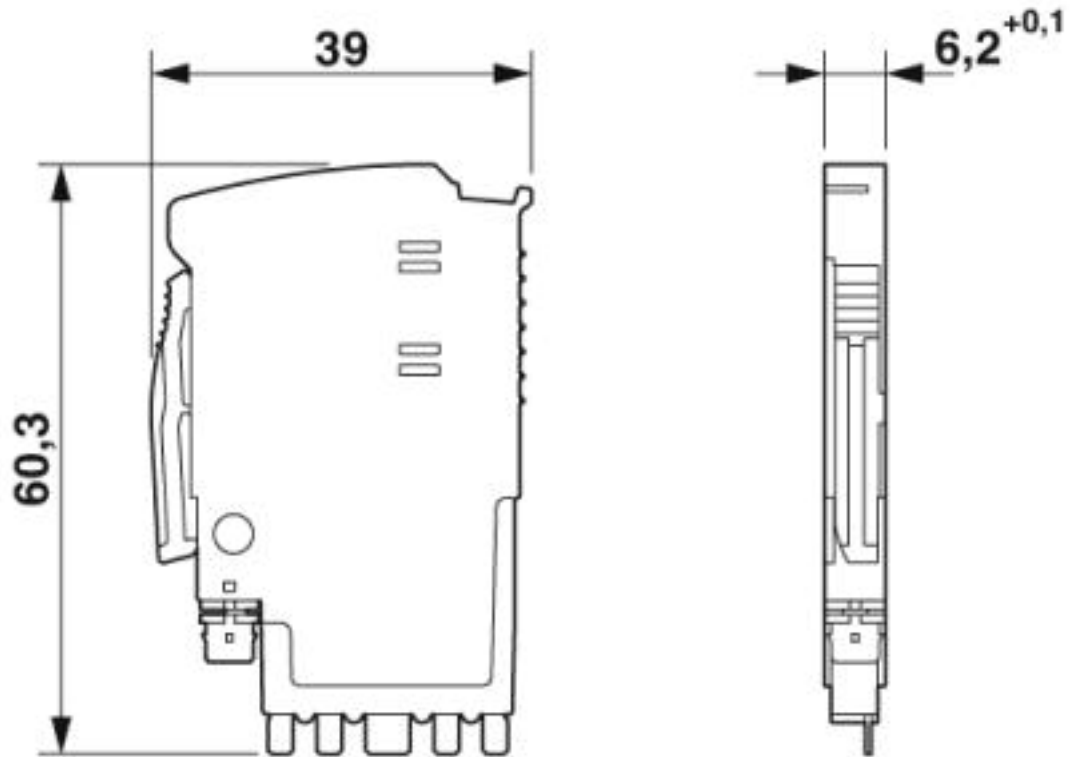

# Surge protection plug - TTC-6P-3-HF-24DC-I-P - 2907847

Circuit diagram

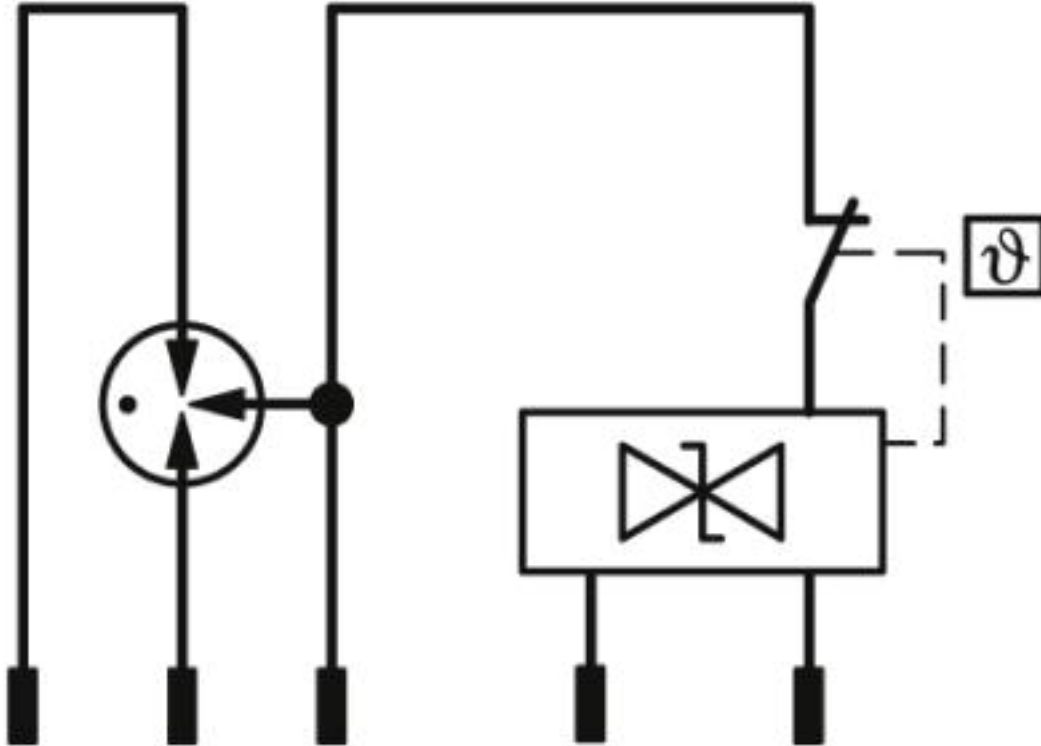

## Classifications

### eCl@ss

eCl@ss 10.0.1	27130890
eCl@ss 6.0	27130800
eCl@ss 7.0	27130890
eCl@ss 8.0	27130890
eCl@ss 9.0	27130890

### ETIM

ETIM 5.0	EC002496
ETIM 6.0	EC002497
ETIM 7.0	EC002497

## Approvals

### Approvals

#### Approvals

DNV GL / CSA / UL Listed / CSAus / cCSAus

# Surge protection plug - TTC-6P-3-HF-24DC-I-P - 2907847

## Approvals

Ex Approvals

### Approval details

DNV GL		<a href="https://approvalfinder.dnvgl.com/">https://approvalfinder.dnvgl.com/</a>	TAE000027G
CSA		<a href="http://www.csagroup.org/services-industries/product-listing/">http://www.csagroup.org/services-industries/product-listing/</a>	70136717
UL Listed		<a href="http://database.ul.com/cgi-bin/XYV/template/LISEXT/1FRAME/index.htm">http://database.ul.com/cgi-bin/XYV/template/LISEXT/1FRAME/index.htm</a>	FILE E 138168
CSAus		<a href="http://www.csagroup.org/services-industries/product-listing/">http://www.csagroup.org/services-industries/product-listing/</a>	70136717
cCSAus			

## Accessories

### Accessories

#### Labeled terminal marker

Zack Marker strip, flat - ZBF 6 CUS - 0825027



Zack Marker strip, flat, Strip, can be ordered: Strip, white, labeled according to customer specifications, mounting type: snap into flat marker groove, for terminal block width: 6.2 mm, lettering field size: 5.15 x 6.15 mm, Number of individual labels: 10

Zack Marker strip, flat - ZBF 6,QR:FORTL.ZAHLEN - 0808765



Zack Marker strip, flat, Strip, white, labeled, Printed vertically: consecutive numbers 1 ... 10, 11 ... 20, etc. up to 91 ... 100, mounting type: snap into flat marker groove, for terminal block width: 6.2 mm, lettering field size: 5.15 x 6.15 mm, Number of individual labels: 10

## Surge protection plug - TTC-6P-3-HF-24DC-I-P - 2907847

### Accessories

---

#### Marker pen

Marker pen - X-PEN 0,35 - 0811228



Marker pen without ink cartridge, for manual labeling of markers, labeling extremely wipe-proof, line thickness 0.35 mm

---

#### Terminal marking

Zack Marker strip, flat - ZBF 6:UNBEDRUCKT - 0808710



Zack Marker strip, flat, Strip, white, unlabeled, can be labeled with: PLOTMARK, CMS-P1-PLOTTER, mounting type: snap into flat marker groove, for terminal block width: 6.2 mm, lettering field size: 5.15 x 6.15 mm, Number of individual labels: 10

---

Zack Marker strip, flat - ZBF 6/WH-100:UNBEDRUCKT - 0808736



Zack Marker strip, flat, Strip, white, unlabeled, can be labeled with: PLOTMARK, CMS-P1-PLOTTER, mounting type: snap into flat marker groove, for terminal block width: 6.2 mm, lettering field size: 5.15 x 6.15 mm, Number of individual labels: 10

---