

## Patch panels - FL-PP-RJ45-SCC/SC041 - 2903532

Please be informed that the data shown in this PDF Document is generated from our Online Catalog. Please find the complete data in the user's documentation. Our General Terms of Use for Downloads are valid (<http://phoenixcontact.com/download>)



Cable sharing module, two RJ45 sockets with Ethernet assignment (cable outlet on the front) to 8 spring-cage connection terminal blocks, CAT5e, 10/100 Mbps, DIN rail mounting, IP20, option of shield contacting on DIN rail via jumpers

### Product Description

Ethernet patch panels enable quick and easy connection between the field cabling and control cabinet cabling. The passive termination panels are a convenient alternative to the on-site assembly of RJ45 connectors.

### Your advantages

- Safe shield connection to ground potential
- CAT5e
- 10/100 Mbps
- Mounting on a DIN rail
- Cable sharing adapter
- Y adapter
- Easy use of one cable for various services
- Optional shield connection via jumpers



### Key Commercial Data

Packing unit	1 pc
GTIN	 4 046356 746748
GTIN	4046356746748
Weight per Piece (excluding packing)	64.300 g
Custom tariff number	85366990
Country of origin	Germany

### Technical data

#### Dimensions

Width	52 mm
Height	90 mm
Depth	51 mm

# Patch panels - FL-PP-RJ45-SCC/SC041 - 2903532

## Technical data

### Ambient conditions

Ambient temperature (operation)	-10 °C ... 50 °C
Degree of protection	IP20

### General

External cable diameter	6 mm ... 10 mm
Mounting position	any
Net weight	64.3 g
Color	green

### Interfaces

Interface 1	Ethernet interface, 10/100/1000Base-T(X) according to IEEE 802.3u
No. of ports	1
Connection method	Spring-cage connection
Transmission length	100 m (including patch cables)
Conductor cross section solid min.	0.2 mm <sup>2</sup>
Conductor cross section solid max.	1.5 mm <sup>2</sup>
Conductor cross section flexible min.	0.2 mm <sup>2</sup>
Conductor cross section flexible max.	1 mm <sup>2</sup>
Conductor cross section AWG min.	24
Conductor cross section AWG max.	16
Pin assignment	1,2,3,6 4,5,7,8
Serial transmission speed	10/100 Mbps
Interface 2	Ethernet interface, 10/100/1000Base-T(X) according to IEEE 802.3u
No. of ports	1
Connection method	RJ45 CAT5e
Pin assignment	1,2,3,6 1,2,3,6

### Conformance/approvals

Designation	Corrosive gas test
Identification	ISA-S71.04-1985 G3 Harsh Group A

### Standards and Regulations

Designation	Air clearances and creepage distances
Standards/regulations	DIN EN 50178
Rated insulation voltage	50 V
Rated surge voltage	0.5 kV
Insulation	Basic insulation
Pollution degree	2
Overvoltage category	II

### Environmental Product Compliance

# Patch panels - FL-PP-RJ45-SCC/SC041 - 2903532

## Technical data

### Environmental Product Compliance

REACH SVHC	Lead 7439-92-1
China RoHS	Environmentally Friendly Use Period = 50
	For details about hazardous substances go to tab "Downloads", Category "Manufacturer's declaration"

## Drawings

Circuit diagram

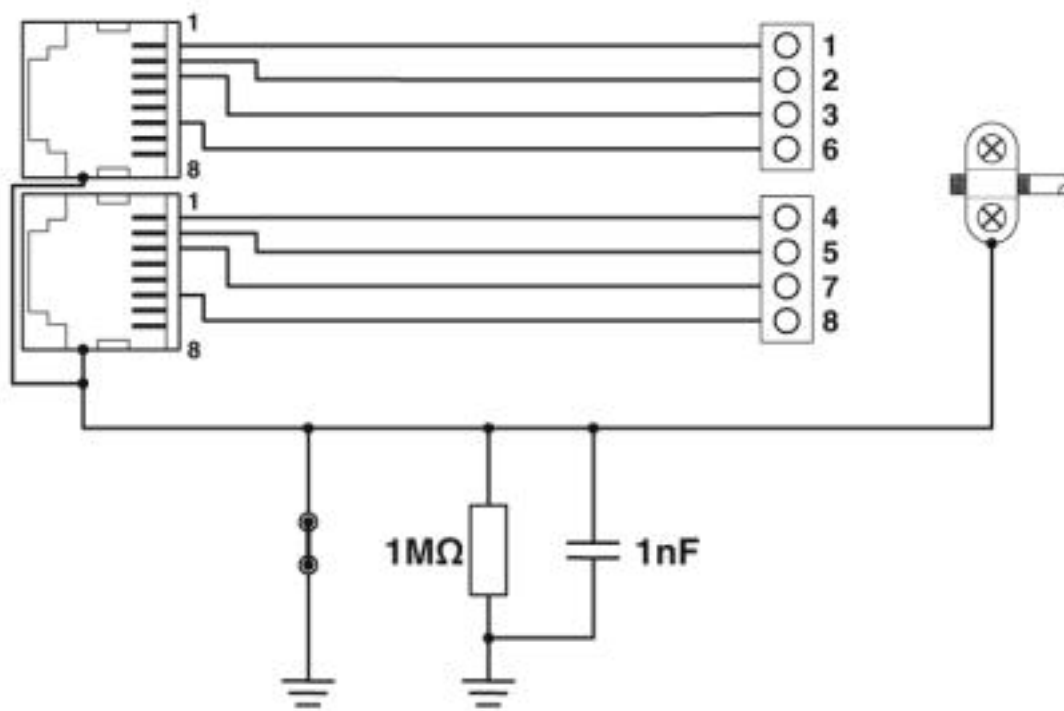

## Patch panels - FL-PP-RJ45-SCC/SC041 - 2903532

Circuit diagram

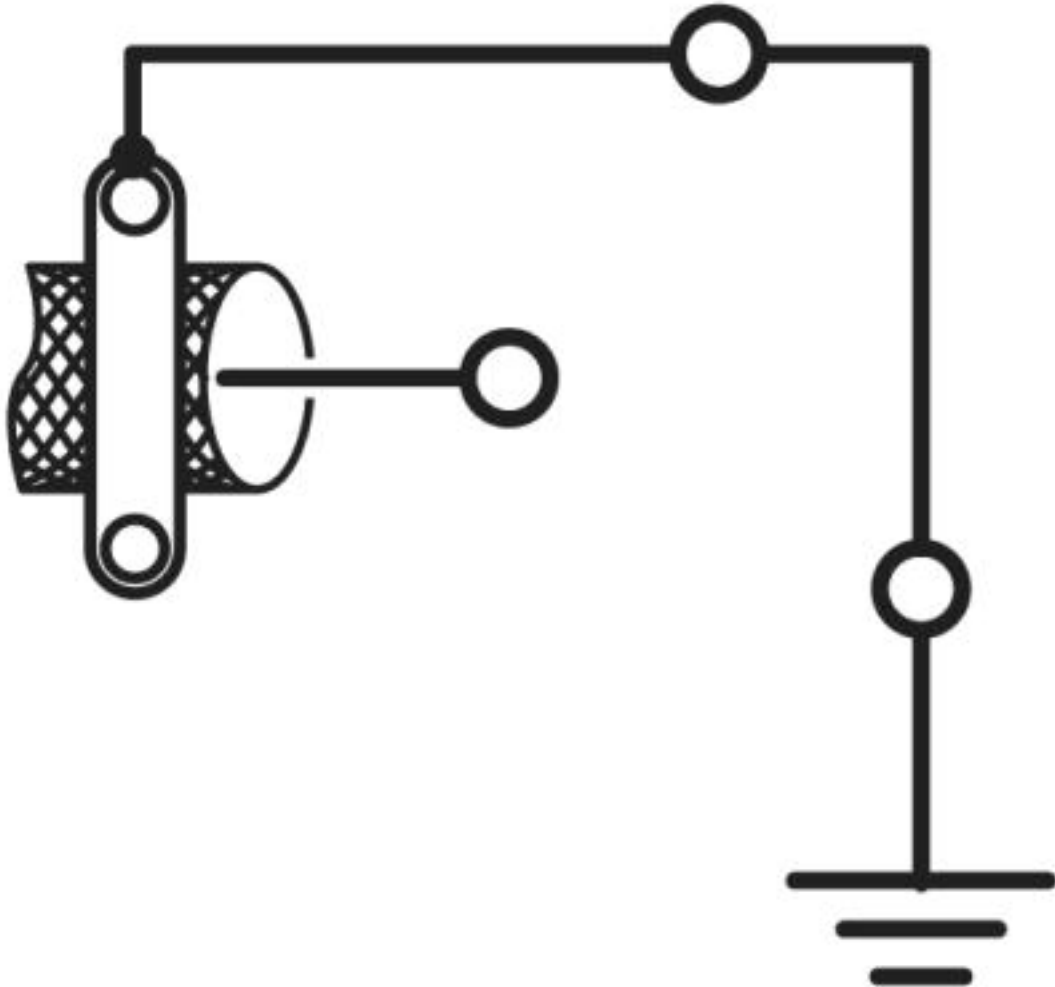

# Patch panels - FL-PP-RJ45-SCC/SC041 - 2903532

Circuit diagram

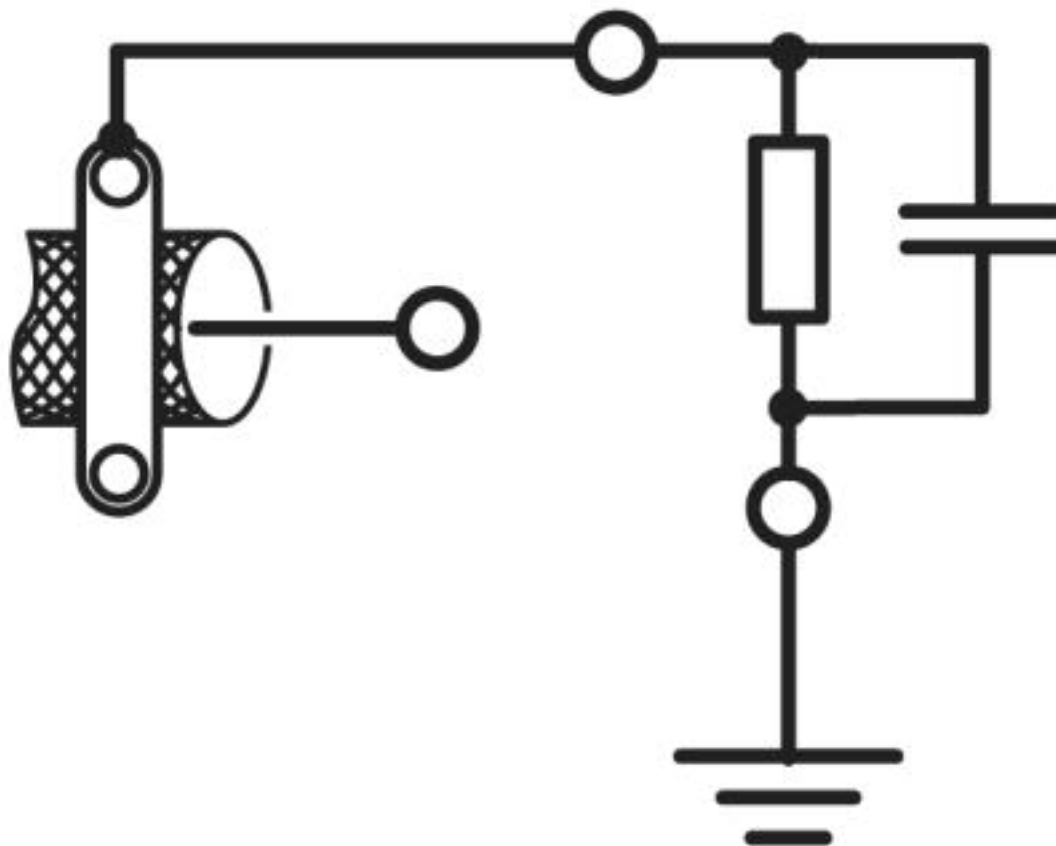

## Patch panels - FL-PP-RJ45-SCC/SC041 - 2903532

Circuit diagram

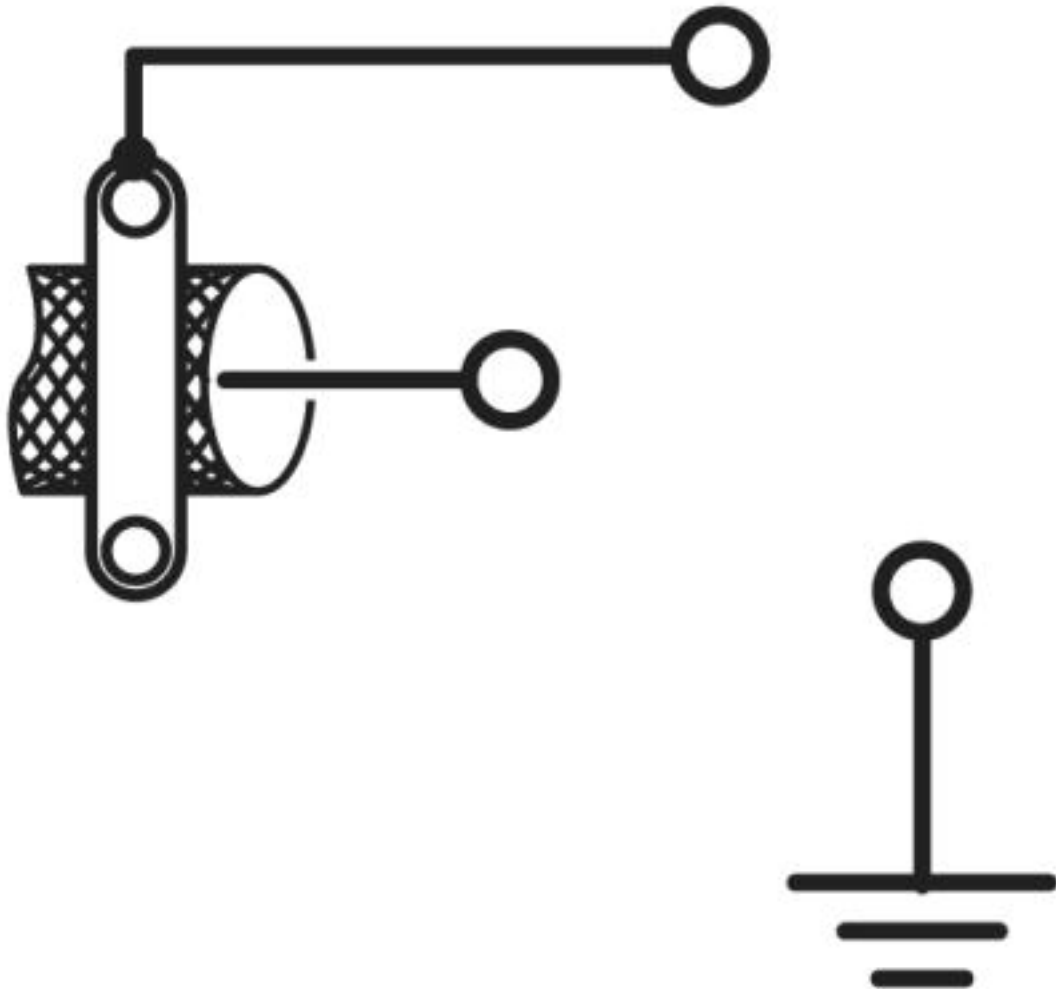

## Patch panels - FL-PP-RJ45-SCC/SC041 - 2903532

Connection diagram

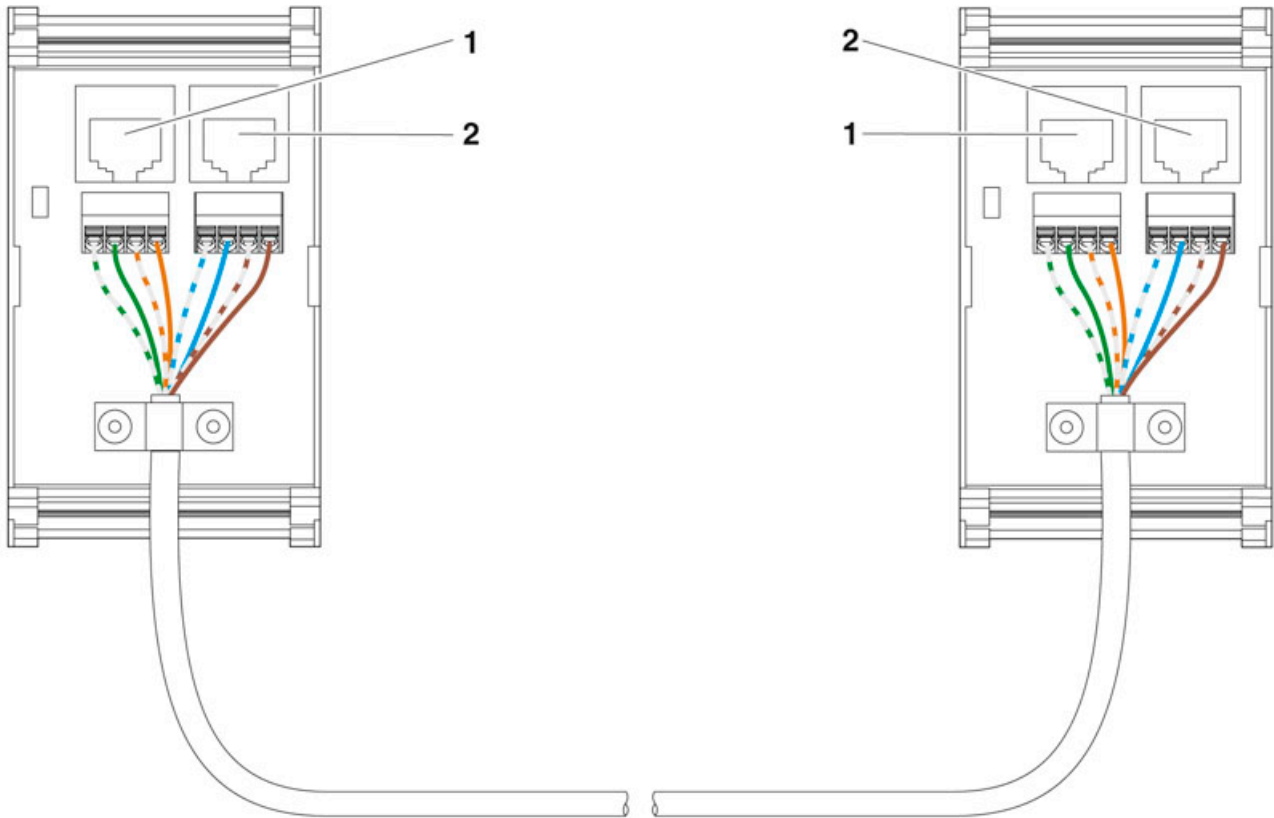

## Patch panels - FL-PP-RJ45-SCC/SC041 - 2903532

### Classifications

#### eCl@ss

eCl@ss 4.0	27230200
eCl@ss 4.1	27230200
eCl@ss 5.0	27230200
eCl@ss 5.1	27230200
eCl@ss 6.0	19170100
eCl@ss 7.0	19170112
eCl@ss 8.0	19170112
eCl@ss 9.0	19170112

#### ETIM

ETIM 3.0	EC000313
ETIM 4.0	EC001128
ETIM 5.0	EC002599
ETIM 6.0	EC002599
ETIM 7.0	EC002599

#### UNSPSC

UNSPSC 6.01	30211506
UNSPSC 7.0901	39121008
UNSPSC 11	39121008
UNSPSC 12.01	39121008
UNSPSC 13.2	26121604
UNSPSC 18.0	43223309
UNSPSC 19.0	43223309
UNSPSC 20.0	43223309
UNSPSC 21.0	43223309

### Accessories

#### Accessories

##### Data cable by the meter

Network cable - VS-OE-OE-93E-100,0 - 1416295



Network cable, Ethernet CAT5 (100 Mbps), 4-position, PUR halogen-free, water blue RAL 5021, shielded, free cable end, on free cable end, cable length: 100 m

##### Data cable preassembled



## Patch panels - FL-PP-RJ45-SCC/SC041 - 2903532

### Accessories

Patch cable - NBC-R4AC-R4AC-IE8A/.../... - 1411854



Patch cable, degree of protection: IP20, number of positions: 8, 10 Gbps, CAT6<sub>A</sub>, cable outlet: straight

---

Patch cable - NBC-R4AC/10G-R4AC/10G-94F/2,0 - 1408360



Patch cable, CAT6<sub>A</sub>, 4-pair, shielded, connection not crossed (line), assembled at both ends with RJ45/IP20 connectors, outer sheath material: PUR, length: 2.0 m

---

Patch cable - NBC-R4AC/10G-R4AC/10G-94F/3,0 - 1408365



Patch cable, CAT6<sub>A</sub>, 4-pair, shielded, connection not crossed (line), assembled at both ends with RJ45/IP20 connectors, outer sheath material: PUR, length: 3.0 m

---

Patch cable - NBC-R4AC/1,0-93B/R4AC - 1408968



PROFINET patch cable, shielded, star-quad, 22 AWG stranded (7-wire), green, straight RJ45 male connector/IP20 to straight RJ45 male connector/IP20, length: 1.0 m

---

Patch cable - NBC-R4AC/2,0-93B/R4AC - 1408969



PROFINET patch cable, shielded, star quad, 22 AWG stranded (7-wire), green, straight RJ45 plug/IP20, to straight RJ45 plug/IP20, length: 2 m

---

### Data plug

## Patch panels - FL-PP-RJ45-SCC/SC041 - 2903532

### Accessories

RJ45 connector - VS-08-RJ45-5-Q/IP20 - 1656725



RJ45 connector, degree of protection: IP20, number of positions: 8, 1 Gbps, CAT5 (IEC 11801:2002), material: PA, connection method: IDC fast connection, connection cross section: AWG 26- 23, cable outlet: straight, color: traffic grey A RAL 7042

---

RJ45 connector - VS-08-RJ45-5-Q/IP20 BK - 1658008



RJ45 connector, degree of protection: IP20, number of positions: 8, 1 Gbps, CAT5 (IEC 11801:2002), material: PA, connection method: IDC fast connection, connection cross section: AWG 26- 23, cable outlet: straight, color: black

---

RJ45 connector - VS-08-RJ45-10G/Q - 1419001



RJ45 connector, IP20, CAT6<sub>A</sub>, 8-pos., with QUICKON fast connection technology, for 26 ... 24 AWG 1-wire and 7-wire conductors, color: black

---

RJ45 connector - VS-PN-RJ45-5-Q/IP20 - 1658435



RJ45 connector, degree of protection: IP20, number of positions: 4, 100 Mbps, CAT5 (IEC 11801:2002), material: PA, connection method: IDC fast connection, cable outlet: straight, color: traffic grey A RAL 7042

---

### Network isolator

Network isolator - FL ISOLATOR 100-RJ/SC - 2313928



Passive network isolator for electrical isolation in Ethernet networks. This protects Ethernet devices from potential differences of up to 4 kV. Can be used for transmission speeds of up to 100 Mbps. Connection using RJ45 and COMBICON plug-in screw terminal block.

---

## Patch panels - FL-PP-RJ45-SCC/SC041 - 2903532

### Accessories

Network isolator - FL ISOLATOR 100-RJ/RJ - 2313931



Passive network isolator for electrical isolation in Ethernet networks. This protects Ethernet devices from potential differences of up to 4 kV. Can be used for transmission speeds of up to 100 Mbps. Possible to connect two RJ45 plugs.

---

Network isolator - FL ISOLATOR 1000-RJ/RJ - 2313915



Passive network isolator for electrical isolation in Ethernet networks. This protects Ethernet devices from potential differences of up to 4 kV. Can be used for transmission speeds of up to 1 Gbps. Possible to connect two RJ45 plugs.

---

### Patch cable

Patch cable - FL CAT5 PATCH 0,3 - 2832250



Patch cable, CAT5, assembled, 0.3 m

---

Patch cable - FL CAT5 PATCH 0,5 - 2832263



Patch cable, CAT5, assembled, 0.5 m

---

Patch cable - FL CAT5 PATCH 1,0 - 2832276



Patch cable, CAT5, assembled, 1 m

---

## Patch panels - FL-PP-RJ45-SCC/SC041 - 2903532

### Accessories

Patch cable - FL CAT5 PATCH 1,5 - 2832221



Patch cable, CAT5, assembled, 1.5 m

---

Patch cable - FL CAT5 PATCH 2,0 - 2832289



Patch cable, CAT5, assembled, 2 m

---

Patch cable - FL CAT5 PATCH 3,0 - 2832292



Patch cable, CAT5, assembled, 3 m

---

### Screwdriver tools

Screwdriver - SZF 0-0,4X2,5 - 1204504



Actuation tool, for ST terminal blocks, also suitable for use as a bladed screwdriver, size: 0.4 x 2.5 x 75 mm, 2-component grip, with non-slip grip

---

Assembly tool - FL CRIMPTOOL - 2744869



Crimping pliers, for assembling the RJ45 plugs FL PLUG RJ45...., for assembly on site

---

## Patch panels - FL-PP-RJ45-SCC/SC041 - 2903532

### Accessories

Stripping tool - VS-CABLE-STRIP-VARIO - 1657407

Stripping tool, for the multi-level stripping of shielded cables



---

Phoenix Contact 2020 © - all rights reserved  
<http://www.phoenixcontact.com>