

Interface converters - FL COMSERVER BASIC 232/422/485 - 2313478

Please be informed that the data shown in this PDF Document is generated from our Online Catalog. Please find the complete data in the user's documentation. Our General Terms of Use for Downloads are valid (<http://phoenixcontact.com/download>)



Second generation FL COMSERVER BASIC..., serial device server for converting a serial RS-232/422/485 interface to Ethernet, only supports TCP and UDP applications, incl. Com Port Redirector software and user documentation (PDF)

Product Description

The FL COMSERVER...232/422/485 products are used to integrate serial V.24 (RS-232)/RS-422/RS-485 interfaces into existing Ethernet networks. This provides an easy way of implementing functions such as cable replacement, network integration or a Modbus gateway.

Your advantages

- Reasonably-priced version
- Software for virtual COM ports supplied as standard
- TCP and UDP support
- Configuration via web-based management
- All connections can be plugged in using a COMBICON screw terminal block



Key Commercial Data

Packing unit	1 pc
GTIN	
GTIN	4046356451314
Weight per Piece (excluding packing)	176.500 g
Custom tariff number	85176200
Country of origin	Germany

Technical data

Note

Utilization restriction	EMC: class A product, see manufacturer's declaration in the download area
-------------------------	---

Dimensions

Width	22.5 mm
Height	99 mm
Depth	116 mm

Interface converters - FL COMSERVER BASIC 232/422/485 - 2313478

Technical data

Ambient conditions

Ambient temperature (operation)	-25 °C ... 60 °C
	-20 °C ... 60 °C (With UL approval)
Ambient temperature (storage/transport)	-25 °C ... 70 °C
Permissible humidity (operation)	10 % ... 95 % (non-condensing)
Permissible humidity (storage/transport)	5 % ... 95 % (non-condensing)
Altitude	≤ 5000 m (For restrictions, see the manufacturer's declaration for altitude operation)
Degree of protection	IP20
Noise immunity	EN 61000-6-2:2005

General

Electrical isolation	DIN EN 50178 (VCC // Ethernet // Serial)
Test voltage data interface/data interface	1.5 kV _{rms} (50 Hz, 1 min.)
Test voltage data interface/power supply	1.5 kV _{rms}
	1.5 kV _{rms} (50 Hz, 1 min.)
Electromagnetic compatibility	Conformance with EMC Directive 2014/30/EU
Noise emission	EN 61000-6-4
Net weight	176.5 g
Housing material	PA 6.6-FR
Color	green
MTBF	666 Years (Telcordia standard, 25°C temperature, 21% operating cycle (5 days a week, 8 hours a day))
	179 Years (Telcordia standard, 40°C temperature, 34.25% operating cycle (5 days a week, 12 hours a day))
MTTF	2001 Years (SN 29500 standard, temperature 25 °C, operating cycle 21 % (5 days a week, 8 hours a day))
	870 Years (SN 29500 standard, temperature 40 °C, operating cycle 34.25 % (5 days a week, 12 hours a day))
	355 Years (SN 29500 standard, temperature 40 °C, operating cycle 100 % (7 days a week, 24 hours a day))

Power supply

Nominal supply voltage	24 V AC/DC ±20 % (via pluggable COMBICON screw terminal block)
	24 V DC ±5 % (as an alternative or redundant, via backplane bus contact and system current supply)
Supply voltage range	19.2 V AC/DC ... 28.8 V AC/DC (via pluggable COMBICON screw terminal block)
	22.8 V DC ... 25.2 V DC (as an alternative or redundant, via backplane bus contact and system current supply)
Typical current consumption	100 mA (24 V DC)

Interfaces

Interface 1	Ethernet interface, 10/100Base-T(X) in acc. with IEEE 802.3u
Interface	Ethernet
No. of ports	1

Interface converters - FL COMSERVER BASIC 232/422/485 - 2313478

Technical data

Interfaces

Connection method	RJ45 socket, shielded
Transmission length	≤ 100 m (shielded twisted pair)
Protocols supported	TCP/IP, UDP
Auxiliary protocols	ARP, DHCP, BOOTP, SNMP, RIP, RARP, HTTP, TFTP, ICMP
Serial transmission speed	10/100 Mbps, auto negotiation
Interface 2	V.24 (RS-232) interface in acc. with ITU-T V.28, EIA/TIA-232, DIN 66259-1
Interface	RS-232
Connection method	D-SUB 9 plug
File format/coding	UART/NRZ: 7/8 Bit Data, 1/2 Bit Stopp, None/Even/Odd Parity
Transmission length	15 m
Pin assignment	DTE/DCE switchover via web-based management
Data flow control/protocols	Software handshake, Xon/Xoff or hardware handshake RTS/CTS
Serial transmission speed	0.3; 0.6; 1.2; 2.4; 4.8; 7.2; 9.6; 19.2; 38.4; 57.6; 115.2; 187.5; 230.4 kbps
Interface 3	RS-422 interface in acc. with ITU-T V.11, EIA/TIA-422, DIN 66348-1
Interface	RS-422
Connection method	Plug-in/screw connection via COMBICON
File format/coding	UART/NRZ: 7/8 Bit Data, 1/2 Bit Stopp, None/Even/Odd Parity
Transmission length	≤ 1200 m
Termination resistor	390 Ω (configurable)
	180 Ω
	390 Ω
Data flow control/protocols	Automatic control
Serial transmission speed	0.3; 0.6; 1.2; 2.4; 4.8; 7.2; 9.6; 19.2; 38.4; 57.6; 115.2; 187.5; 230.4; 500; 1000 kbps
Interface 4	RS-485 interface, in acc. with EIA/TIA-485, DIN 66259-4/RS-485 2-wire
Interface	RS-485
Connection method	Plug-in/screw connection via COMBICON
File format/coding	UART/NRZ: 7/8 Bit Data, 1/2 Bit Stopp, None/Even/Odd Parity
Termination resistor	390 Ω (configurable)
	180 Ω
	390 Ω
Data flow control/protocols	Automatic control
Serial transmission speed	0.3; 0.6; 1.2; 2.4; 4.8; 7.2; 9.6; 19.2; 38.4; 57.6; 115.2; 187.5; 230.4; 500; 1000 kbps

Function

Web-based management	yes
Management	Web-based management, SNMP, emergency exit with Telnet and serial
Status and diagnostic indicators	LEDs: UL (logic voltage), TD + RD (data activity serial), FD (full duplex), 100 (100 Mbps mode), Link (Ethernet), Activity (Ethernet), ERR (error)
Management	Web-based management

Interface converters - FL COMSERVER BASIC 232/422/485 - 2313478

Technical data

Function

	SNMP v1/v2
--	------------

Conformance/approvals

Designation	CE
Identification	CE-compliant
Designation	EAC
Identification	EAC
Designation	ATEX
Identification	# II 3G Ex nA IIC T4 Gc X
Additional text	Please follow the special installation instructions in the documentation!
Designation	UL, USA/Canada
Identification	508 Listed
	Class I, Div. 2, Groups A, B, C, D
Designation	UL, USA
Identification	Class I, Zone 2, AEx nA IIC T5
Designation	UL, Canada
Identification	Class I, Zone 2, Ex nA IIC T5 Gc X
Designation	Corrosive gas test
Identification	ISA-S71.04-1985 G3 Harsh Group A

Standards and Regulations

Electromagnetic compatibility	Conformance with EMC Directive 2014/30/EU
Type of test	Free fall in acc. with IEC 60068-2-32
Test result	1 m
Type of test	Vibration resistance in acc. with EN 60068-2-6/IEC 60068-2-6
Test result	5g, 10...150 Hz, 2.5 h, in XYZ direction
Type of test	Shock in acc. with EN 60068-2-27/IEC 60068-2-27
Test result	15g, 11 ms period, half-sine shock pulse
Type of test	Shock in acc. with EN 60068-2-27/IEC 60068-2-27
Test result	30g, 11 ms period, half-sine shock pulse
Noise emission	EN 61000-6-4
Noise immunity	EN 61000-6-2:2005
Free from substances that could impair the application of coating	according to P-VW 3.10.7 57 65 0 VW-AUDI-Seat central standard
Standards/regulations	EN 50121-4

Environmental Product Compliance

REACH SVHC	Lead 7439-92-1
China RoHS	Environmentally Friendly Use Period = 50
	For details about hazardous substances go to tab "Downloads", Category "Manufacturer's declaration"

Drawings

Interface converters - FL COMSERVER BASIC 232/422/485 - 2313478

Connection diagram

FL COMSERVER RS-485

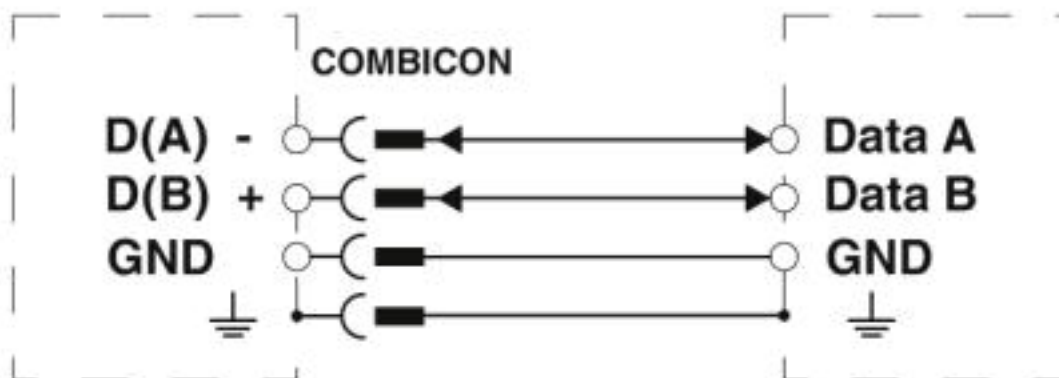

RS-485 connection

Connection diagram

FL COMSERVER RS-422

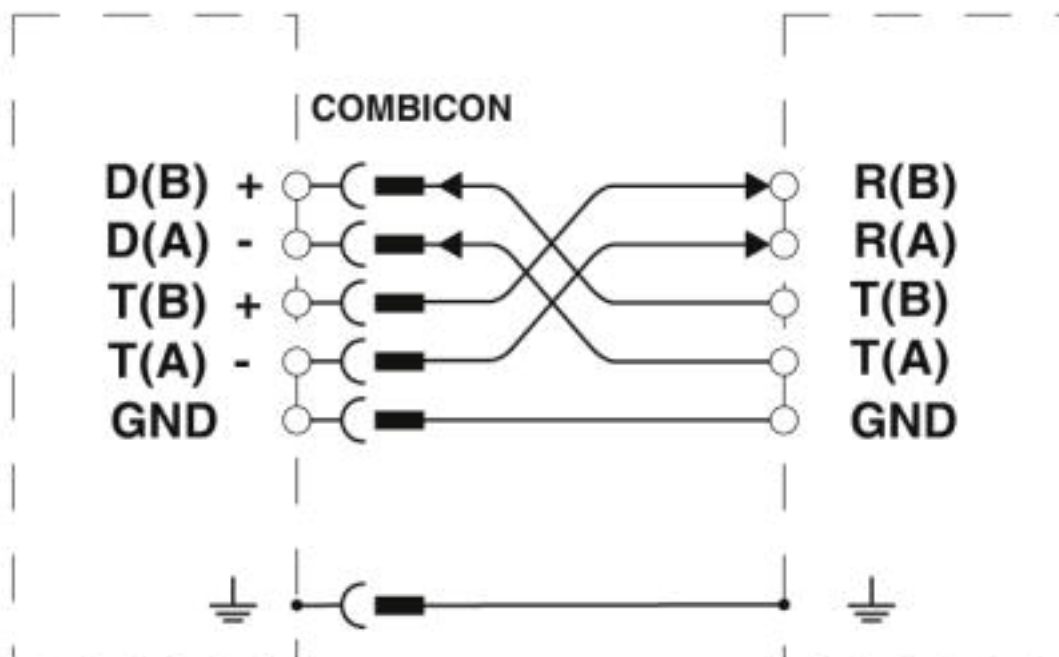

RS-422 connection

Interface converters - FL COMSERVER BASIC 232/422/485 - 2313478

Application drawing

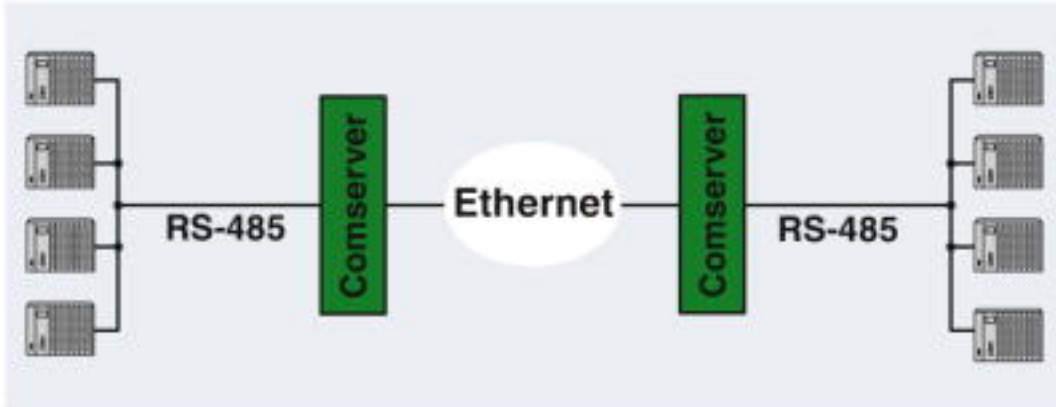

Increasing the range with FL COMSERVER

Application drawing

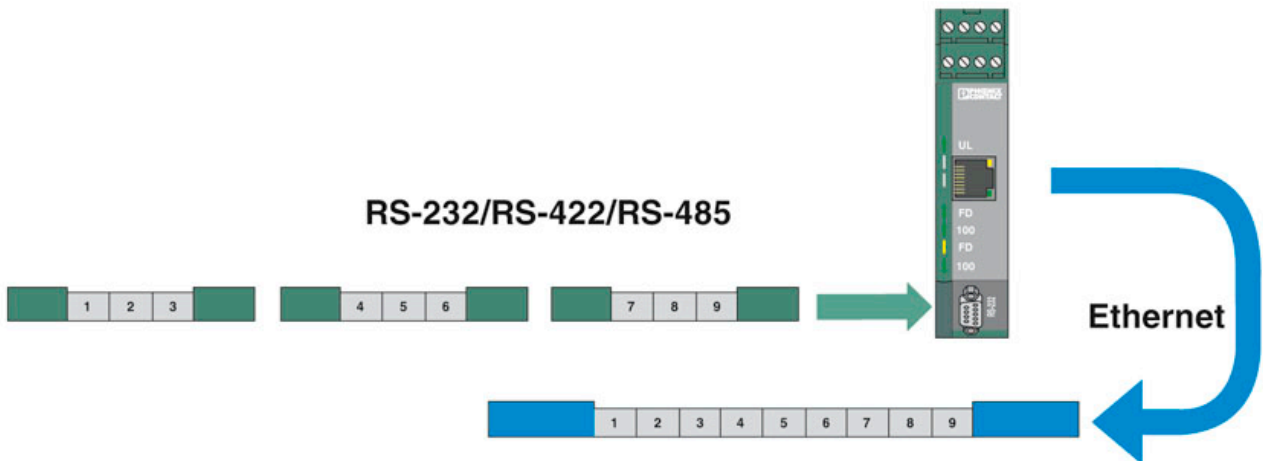

Large value: "Idle Force Timeout Characters"

Interface converters - FL COMSERVER BASIC 232/422/485 - 2313478

Application drawing

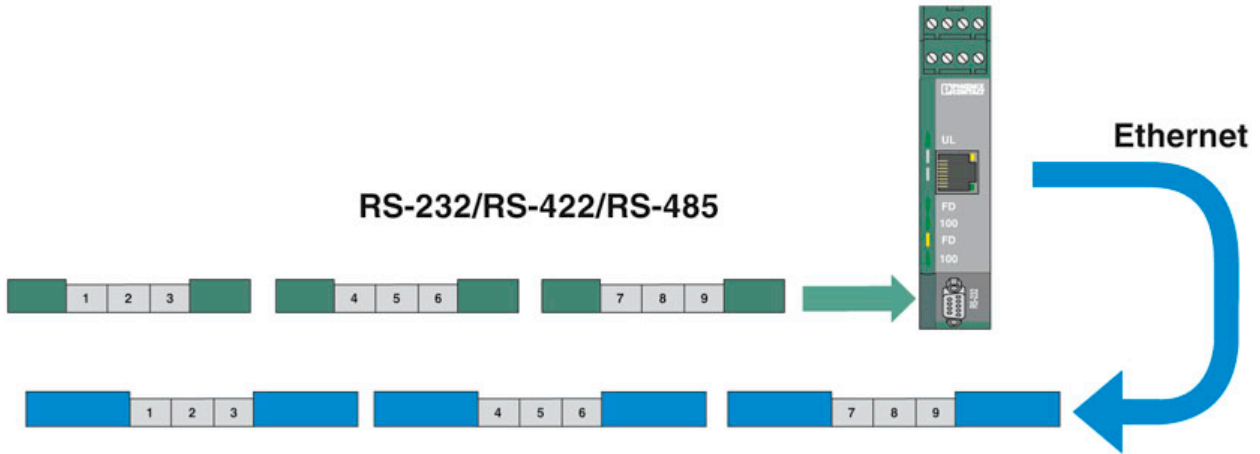

Small value: "Idle Force Timeout Characters"

Interface converters - FL COMSERVER BASIC 232/422/485 - 2313478

Application drawing

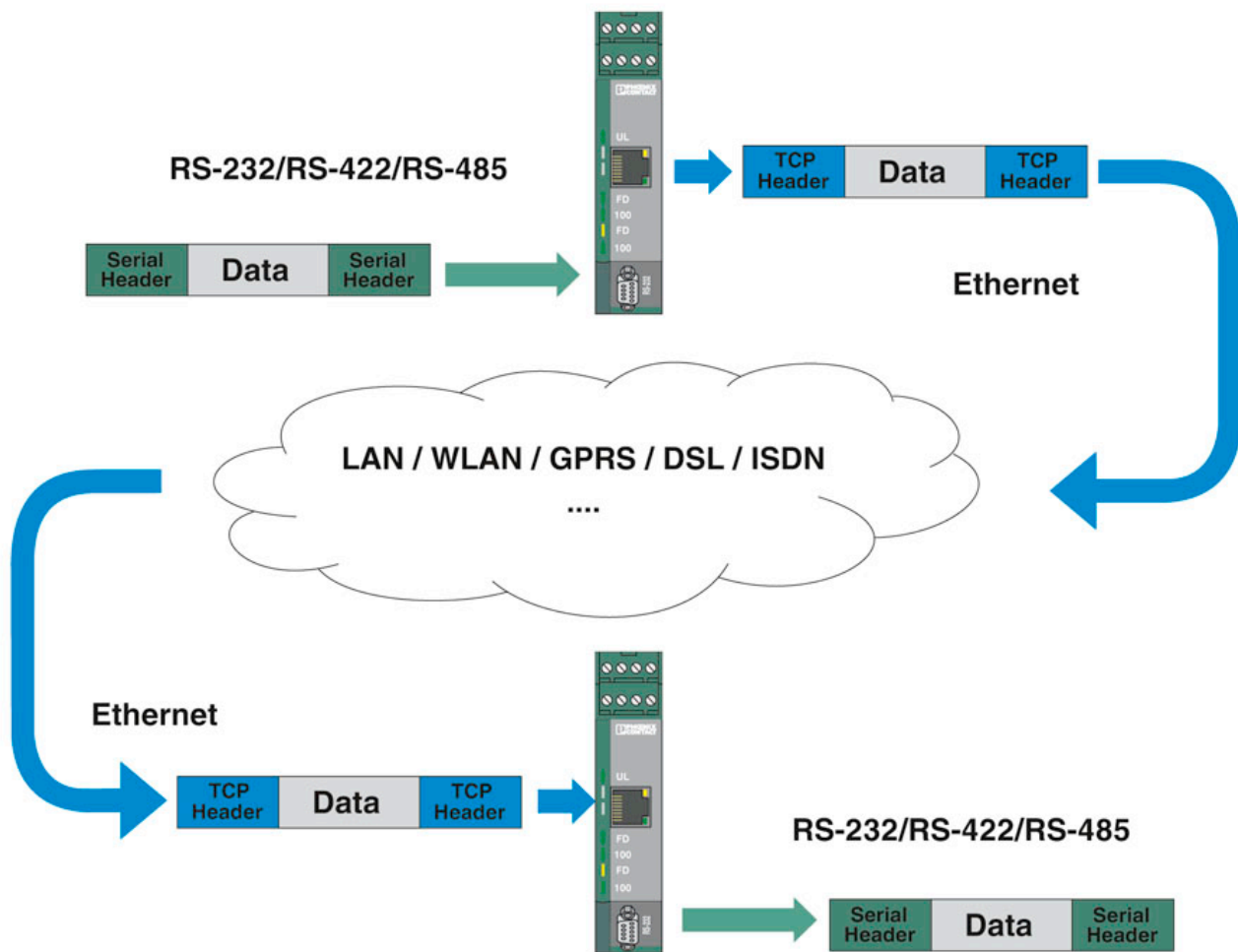

Interface converters - FL COMSERVER BASIC 232/422/485 - 2313478

Classifications

eCl@ss

eCl@ss 10.0.1	19179290
eCl@ss 4.0	27250500
eCl@ss 4.1	27250500
eCl@ss 5.0	27250500
eCl@ss 5.1	27250500
eCl@ss 6.0	19179200
eCl@ss 7.0	19179290
eCl@ss 8.0	19179290
eCl@ss 9.0	19179290

ETIM

ETIM 2.0	EC000310
ETIM 3.0	EC000310
ETIM 4.0	EC000310
ETIM 5.0	EC000310
ETIM 6.0	EC000310
ETIM 7.0	EC000310

UNSPSC

UNSPSC 6.01	30211506
UNSPSC 7.0901	39121008
UNSPSC 11	39121008
UNSPSC 12.01	39121008
UNSPSC 13.2	43222604
UNSPSC 18.0	43222604
UNSPSC 19.0	43222604
UNSPSC 20.0	43222604
UNSPSC 21.0	43222604

Approvals

Approvals

Approvals

UL Listed / cUL Listed / EAC / KC / EAC / cULus Listed

Ex Approvals

ATEX / UL Listed / cUL Listed / cULus Listed

Approval details

Interface converters - FL COMSERVER BASIC 232/422/485 - 2313478

Approvals

UL Listed		http://database.ul.com/cgi-bin/XYV/template/LISEXT/1FRAME/index.htm	FILE E 238705
-----------	--	---	---------------

cUL Listed		http://database.ul.com/cgi-bin/XYV/template/LISEXT/1FRAME/index.htm	FILE E 238705
------------	--	---	---------------

EAC			EAC-Zulassung
-----	--	--	---------------

KC		http://eng.kcc.go.kr/user/ehpMain.do	KCC-REI- PCK-FL231347
----	--	---	--------------------------

EAC			RU *- DE.A*30.B.01735
-----	--	--	--------------------------

cULus Listed			
--------------	--	--	--

Accessories

Accessories

Adapter cable

Data cable - PSM-KA9SUB9/BB/2METER - 2799474



RS-232 cable, 9-pos. D-SUB socket on 9-pos. D-SUB socket, 9-wire, 1:1

Arrester test system

Interface converters - FL COMSERVER BASIC 232/422/485 - 2313478

Accessories

Cable - CM-KBL-RS232/USB - 2881078



Connecting cable D-9-SUB to USB, with adapter D-9-SUB to D-25-SUB.

Data cable by the meter

Network cable - FL CAT5 HEAVY - 2744814



CAT5-SF/UTP cable (J-02YS(ST)C HP 2 x 2 x 24 AWG), heavy-duty installation cable, 2 x 2 x 0.22 mm², solid conductor, shielded, outer sheath: 7.8 mm diameter, inner sheath: 5.75 mm ± 0.15 mm diameter

Network cable - FL CAT5 FLEX - 2744830



CAT5-SF/UTP cable (J-LI02YS(ST)C H 2 x 2 x 26 AWG), light-duty, flexible installation cable 2 x 2 x 0.14 mm², stranded, shielded, outer sheath: 5.75 mm ± 0.15 mm diameter

Data plug

RJ45 connector - VS-08-RJ45-5-Q/IP20 - 1656725



RJ45 connector, degree of protection: IP20, number of positions: 8, 1 Gbps, CAT5 (IEC 11801:2002), material: PA, connection method: IDC fast connection, connection cross section: AWG 26- 23, cable outlet: straight, color: traffic grey A RAL 7042

D-SUB bus connector - SUBCON 9/F-SH - 2761499



D-SUB plug, 9-pos. female connector, one cable entry < 35°, universal type for all systems, pin assignment: 1, 2, 3, 4, 5, 6, 7, 8, 9 to screw connection terminal block

DIN rail connector

Interface converters - FL COMSERVER BASIC 232/422/485 - 2313478

Accessories

DIN rail bus connectors - ME 22,5 TBUS 1,5/ 5-ST-3,81 GN - 2707437



DIN rail connector, number of positions: 5, pitch: 3.81 mm, pin layout: Linear pinning, Articles with gold-plated contacts, bus connectors for connecting with electronic housings

Interface converter

Interface converters - FL COMSERVER UNI 232/422/485 - 2313452



Second generation FL COMSERVER UNI..., serial device server for converting a serial 232/422/485 interface to Ethernet, supports TCP, UDP, Modbus gateway, and PPP applications, incl. COM port redirector software and user documentation

Media converter

FO converters - FL MC EF 1300 MM SC - 2902853



FO converter with SC duplex fiber optic connection (1300 nm), for converting 10/100Base-T(X) to multi-mode fiberglass (50/125 µm). Auto negotiation and auto MDI(X) function. Comprehensive link diagnostics. DIN-rail mountable, 18 ... 30 V DC supply.

Modem

Modem - PSI-MODEM-SHDSL/ETH - 2313643



First generation: Unmanaged Ethernet extender for point-to-point connections, line and ring structures, data rates up to 30 Mbps, distances of up to 20 km on in-house copper cables, diagnostics via USB and LEDs, 2 SHDSL ports, 1 LAN port

Modem - PSI-MODEM-SHDSL/SERIAL - 2313669



Industrial SHDSL extender for serial RS-232/422/485 interfaces, point-to-point and line structures, serial data transmission up to 2000 kbps on in-house cables, diagnostics via USB and LEDs, two configurable alarm outputs

Mounting material

Interface converters - FL COMSERVER BASIC 232/422/485 - 2313478

Accessories

Shield connection clamp - ME-SAS - 2853899



Shield connection clamp for printed circuit terminal block

Network isolator

Network isolator - FL ISOLATOR 100-RJ/RJ - 2313931



Passive network isolator for electrical isolation in Ethernet networks. This protects Ethernet devices from potential differences of up to 4 kV. Can be used for transmission speeds of up to 100 Mbps. Possible to connect two RJ45 plugs.

Patch cable

Patch cable - FL CAT5 PATCH 0,5 - 2832263



Patch cable, CAT5, assembled, 0.5 m

Patch cable - FL CAT5 PATCH 5,0 - 2832580



Patch cable, CAT5, assembled, 5 m

Patch panel

Patch panels - FL-PP-RJ45-SCC - 2901642



Patch panel, one RJ45 socket to 8 spring-cage connection terminal blocks (1:1 assignment), CAT5e, 10/100/1000 Mbps, DIN rail mounting, IP20, option of shield contacting on DIN rail via jumpers

Power supply

Interface converters - FL COMSERVER BASIC 232/422/485 - 2313478

Accessories

Power supply unit - MINI-SYS-PS-100-240AC/24DC/1.5 - 2866983



Primary-switched MINI POWER supply for DIN rail mounting, input: 1-phase, output: 24 V DC/1.5 A

Safety locking

Port Guard Security Element - FL PATCH SAFE CLIP - 2891246



Security element for FL patch cable

Screwdriver tools

Screwdriver - SZF 1-0,6X3,5 - 1204517



Actuation tool, for ST terminal blocks, also suitable for use as a bladed screwdriver, size: 0.6 x 3.5 x 100 mm, 2-component grip, with non-slip grip

Surge protection for information technology

Surge protection device - DT-LAN-CAT.6+ - 2881007



Surge protection in accordance with Class E_A (CAT6_A), for Gigabit Ethernet (up to 10 Gbps), token ring, FDDI/CDDI, ISDN, and DS1. Suitable for Power over Ethernet (PoE+) "Mode A" and "Mode B". RJ45 attachment plug with separate grounding cable and ground connection snap-on foot for NS 35 DIN rails.

Switch

Industrial Ethernet Switch - FL SWITCH SFNT 5TX - 2891003



Wide-temperature Ethernet switch, 5 TP RJ45 ports, automatic detection of data transmission speed of 10/100 Mbps (RJ45), autocrossing function, reads QoS priority messages, accepts security frames

Interface converters - FL COMSERVER BASIC 232/422/485 - 2313478

Accessories

Additional products

Interface converters - FL COMSERVER UNI 232/422/485 - 2313452



Second generation FL COMSERVER UNI..., serial device server for converting a serial 232/422/485 interface to Ethernet, supports TCP, UDP, Modbus gateway, and PPP applications, incl. COM port redirector software and user documentation