

Profile - UM100-PROFIL 200CM - 2906319

Please be informed that the data shown in this PDF Document is generated from our Online Catalog. Please find the complete data in the user's documentation. Our General Terms of Use for Downloads are valid (<http://phoenixcontact.com/download>)

Profile housing and board base, with a constructional width of 100 mm and a fixed length of 200 cm



Key Commercial Data

Packing unit	1 CM
GTIN	 4 017918 277451
GTIN	4017918277451
Weight per Piece (excluding packing)	955.000 g
Custom tariff number	39162000
Country of origin	Germany

Technical data

Product properties

Brief article description	Profile
Type	UM100-PROFIL 200CM
Order No.	2906319
Housing type	Press-drawn section housings
Type	Basic profile

Dimensions

Length	2 m
Width	2000 mm
Profile width (external)	122.6 mm
Profile width (internal)	100 mm
Depth	21.5 mm

Material specifications

Housing material	PVC
------------------	-----

Profile - UM100-PROFIL 200CM - 2906319

Technical data

Ambient conditions

Ambient temperature (operation)	-15 °C ... 50 °C
---------------------------------	------------------

Packaging specifications

Pieces per package	1
Denomination packing units	Pcs.

Standards and Regulations

Flammability rating according to UL 94	V0
--	----

Environmental Product Compliance

China RoHS	Environmentally friendly use period: unlimited = EFUP-e
	No hazardous substances above threshold values

Drawings

Dimensional drawing

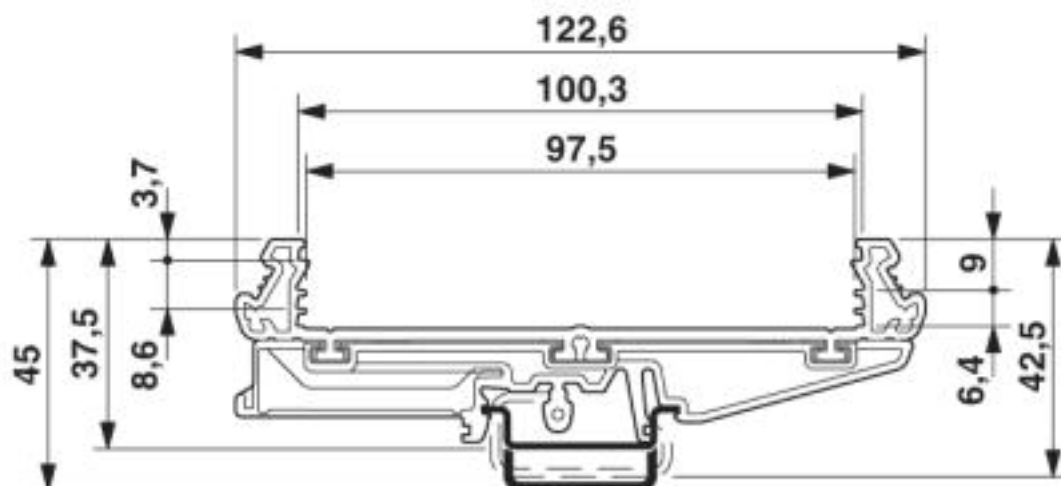

Classifications

eCl@ss

eCl@ss 10.0.1	27182701
eCl@ss 4.0	27180400
eCl@ss 4.1	27180400
eCl@ss 5.0	27180500
eCl@ss 5.1	27180500
eCl@ss 6.0	27180800
eCl@ss 7.0	27182701
eCl@ss 8.0	27182701
eCl@ss 9.0	27182701

Profile - UM100-PROFIL 200CM - 2906319

Classifications

ETIM

ETIM 2.0	EC001031
ETIM 3.0	EC001031
ETIM 4.0	EC001031
ETIM 5.0	EC002779
ETIM 6.0	EC002779
ETIM 7.0	EC002779

UNSPSC

UNSPSC 6.01	31261501
UNSPSC 7.0901	31261501
UNSPSC 11	31261501
UNSPSC 12.01	31261501
UNSPSC 13.2	31261501
UNSPSC 18.0	31261501
UNSPSC 19.0	31261501
UNSPSC 20.0	31261501
UNSPSC 21.0	31261501

Approvals

Approvals

Approvals

EAC

Ex Approvals

Approval details

EAC		B.01742
-----	---	---------

Accessories

Accessories

Component housing cover

Profile - UM100-PROFIL 200CM - 2906319

Accessories

Covering hood - UM108-A/U CM - 2854898



Press-drawn section housings, Cover, 73 mm wide, width: 73 mm, Note: length of the cover = length of the press-drawn section used

Covering hood - UM-A/U N 73 CM - 2706852



Press-drawn section housings, Cover, 73 mm wide, width: 73 mm, Note: length of the cover = length of the press-drawn section used

Component housing lower part

Side element - UM108-LG 10 - 2959780



Profile housing and board base, 10 mm wide module, consisting of two side elements

Mounting material

Foot element - UM108-FE - 2959463



Foot element, 107.5 mm wide, for mounting on NS 32 or NS 35/7.5, below profile housing UM 108.

Mounting flange - UMK-BF - 2976077



Mounting flange, for mounting directly on the wall

Profile - UM100-PROFIL 200CM - 2906319

Accessories

Foot element - UM108-FE - 2959463

Foot element, 107.5 mm wide, for mounting on NS 32 or NS 35/7.5, below profile housing UM 108.



Mounting flange - UMK-BF - 2976077

Mounting flange, for mounting directly on the wall



Panel mounting base side part

Side element - UM108-SE - 2959476

Side element, 5 mm wide, PCB width: 107.5 mm



Side element - UM108-SEFE/R-A60 - 2959706

Side element, with foot, tall version, right-hand, for 60 mm wide U-shaped cover.



Side element - UM108-SEFE/R-A73 - 2959719

Side element, with foot, tall version, right-hand, for 73 mm wide U-shaped cover.



Profile - UM100-PROFIL 200CM - 2906319

Accessories

Side element - UM108 N-SEFE/R-A73 - 2709354



Side element, with foot, low-profile version, right-hand, for 73 mm wide U-shaped cover.

Side element - UM108-SEFE/L-A60 - 2959722



Side element, with foot, tall version, left-hand, for 60 mm wide U-shaped cover.

Side element - UM108-SEPEF/L-A60 - 2906500



Side element with foot, tall design, left-hand, for 60 mm wide U-shaped cover, with PE contact to the DIN rail.

Side element - UM108-SEFE/L-A73 - 2959735



Side element, with foot, tall version, left-hand, for 73 mm wide U-shaped cover.

Side element - UM108-SEPEF/L-A73 - 2906513



Side element with foot, tall design, left, for 73 mm wide U-shaped cover, with PE contact to the DIN rail.

Profile - UM100-PROFIL 200CM - 2906319

Accessories

Side element - UM108 N-SEFE/L-A73 - 2709367

Side element, with foot, low-profile version, left-hand, for 73 mm wide U-shaped cover.



Side element - UM108 N-SEPEF/L-A73 - 2709370

Side element with foot, low-profile design, left, for 73 mm wide U-shaped cover, with PE contact to the DIN rail.



Side element - UM108-SE-A60 - 2959748

Side element, without foot, tall version, for 60 mm wide U-shaped cover.



Side element - UM108-SE-A73 - 2959751

Side element, without foot, tall version, for 73 mm wide U-shaped cover.



Side element - UM108 N-SE-A73 - 2709383

Side element, without foot, low-profile version, for 73 mm wide U-shaped cover.

