

T box - DC-B 6-HTC-M25-M25-M - 1581052

Please be informed that the data shown in this PDF Document is generated from our Online Catalog. Please find the complete data in the user's documentation. Our General Terms of Use for Downloads are valid (<http://phoenixcontact.com/download>)



DUPLICON, aluminum T-box, type B6, IP67 protection, 2 x M25 cable screw connection thread (without cable screw connection)



Key Commercial Data

Packing unit	10 pc
GTIN	
GTIN	4046356154840
Weight per Piece (excluding packing)	248.960 g
Custom tariff number	85389099
Country of origin	Slovenia
Note	Made to Order (non-returnable)

Technical data

Dimensions

Height	72 mm
Width	81 mm
Length	81 mm

Ambient conditions

Degree of protection of housing (IP)	IP65
	IP66
	IP67
Ambient temperature (operation)	-40 °C ... 125 °C

General

Size	DC-B6
Number of positions	0
Housing type	Box mounting bases
Color	gray aluminum

T box - DC-B 6-HTC-M25-M25-M - 1581052

Technical data

General

Locking type	Double locking latch
No. of cable outlets	2
Cable outlet	lateral
Screw connection	none
Type of the screw connection	with M25 thread
Protective cover	no
Housing material	Aluminum die-cast
Housing surface material	uncoated

Environmental Product Compliance

China RoHS	Environmentally friendly use period: unlimited = EFUP-e
	No hazardous substances above threshold values

Drawings

Dimensional drawing

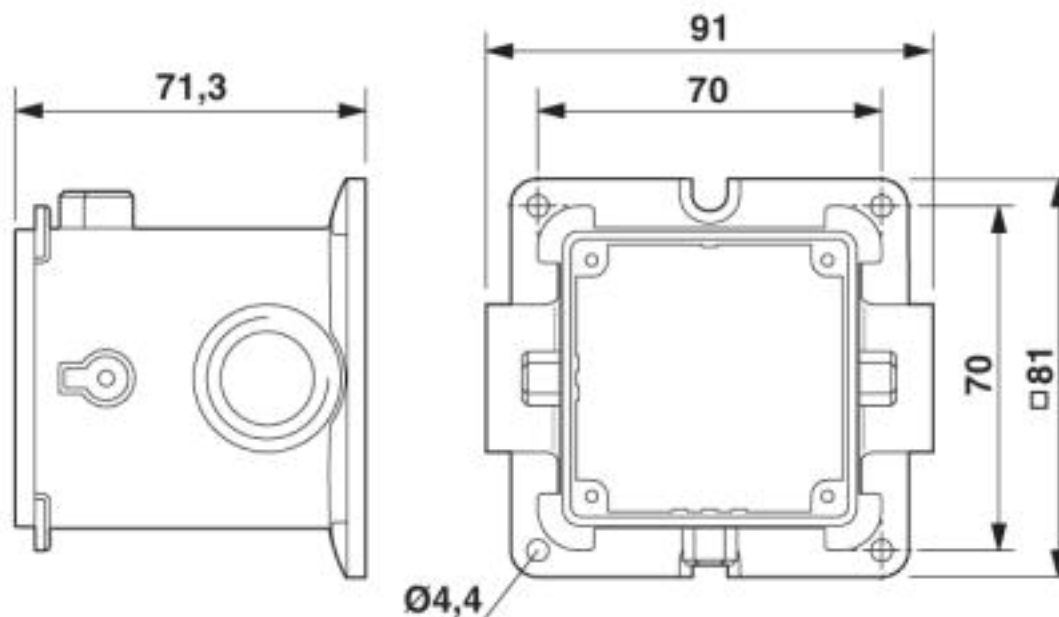

Dimensional drawing

Classifications

eCl@ss

eCl@ss 10.0.1	27440202
eCl@ss 4.0	27140800
eCl@ss 4.1	27140800
eCl@ss 5.0	27143400

T box - DC-B 6-HTC-M25-M25-M - 1581052

Classifications

eCl@ss

eCl@ss 5.1	27261200
eCl@ss 6.0	27261200
eCl@ss 7.0	27440202
eCl@ss 9.0	27440202

ETIM

ETIM 3.0	EC000437
ETIM 4.0	EC000437
ETIM 5.0	EC000437
ETIM 6.0	EC000437
ETIM 7.0	EC000437

UNSPSC

UNSPSC 6.01	31261502
UNSPSC 7.0901	31261502
UNSPSC 11	31261502
UNSPSC 12.01	31261502
UNSPSC 13.2	31261501
UNSPSC 18.0	31261501
UNSPSC 19.0	31261501
UNSPSC 20.0	31261501
UNSPSC 21.0	31261501

Approvals

Approvals

Approvals

VDE Gutachten mit Fertigungsüberwachung

Ex Approvals

Approval details

VDE Gutachten mit Fertigungsüberwachung		http://www2.vde.com/de/Institut/Online-Service/VDE-gepruefteProdukte/Seiten/Online-Suche.aspx	40017400
Nominal voltage UN	690 V		
Nominal current IN	25 A		

T box - DC-B 6-HTC-M25-M25-M - 1581052

Accessories

Accessories

Device marking

Label - EML (26,5X12)R SR - 0816854



Label, Roll, silver/matt, unlabeled, can be labeled with: THERMOMARK ROLLMASTER 300/600, THERMOMARK X1.2, THERMOMARK ROLL X1, THERMOMARK ROLL 2.0, THERMOMARK ROLL, mounting type: adhesive, lettering field size: 26.5 x 12 mm, Number of individual labels: 2500

Full screw connection

Cable gland - HC-M-KV-M25(14-21) - 1646007



Metal screw connection up to 5 bar, thread length: 7 mm, cable diameter: 14 - 21 mm, WAF 34, screw connection: M25

Protective cover

Dust protection cover - DC-B 6-CT-P - 1581078



DUPLICON snap-on dust protection cover, polyamide (can be coated)