

# **INVERTER**

## **FR-D700 SC**

### **INSTALLATION GUIDELINE**

#### **FR-D720S-008SC to 100SC-EC**

#### **FR-D740-012SC to 160SC-EC**

Thank you for choosing this Mitsubishi Electric inverter.  
Please read through this Installation Guideline and the enclosed CD ROM to operate this inverter correctly.  
Do not use this product until you have a full knowledge of the equipment, the safety information and the instructions.  
Please forward this Installation Guideline and the CD ROM to the end user.

#### **CONTENTS**

<b>{1}</b>	<b>PRODUCT DESCRIPTION .....</b>	<b>1</b>
<b>{2}</b>	<b>INSTALLATION OF THE INVERTER AND INSTRUCTIONS.....</b>	<b>2</b>
<b>{3}</b>	<b>OUTLINE DIMENSION DRAWING .....</b>	<b>4</b>
<b>{4}</b>	<b>WIRING .....</b>	<b>5</b>
<b>{5}</b>	<b>PRECAUTIONS FOR USE OF THE INVERTER .....</b>	<b>13</b>
<b>{6}</b>	<b>FAILSAFE OF THE SYSTEM WHICH USES THE INVERTER .....</b>	<b>15</b>
<b>{7}</b>	<b>PARAMETER.....</b>	<b>16</b>
<b>{8}</b>	<b>TROUBLESHOOTING.....</b>	<b>21</b>
<b>{9}</b>	<b>MAINTENANCE AND INSPECTION .....</b>	<b>24</b>
<b>{10}</b>	<b>SPECIFICATIONS .....</b>	<b>25</b>
<b>{A}</b>	<b>APPENDIX .....</b>	<b>26</b>

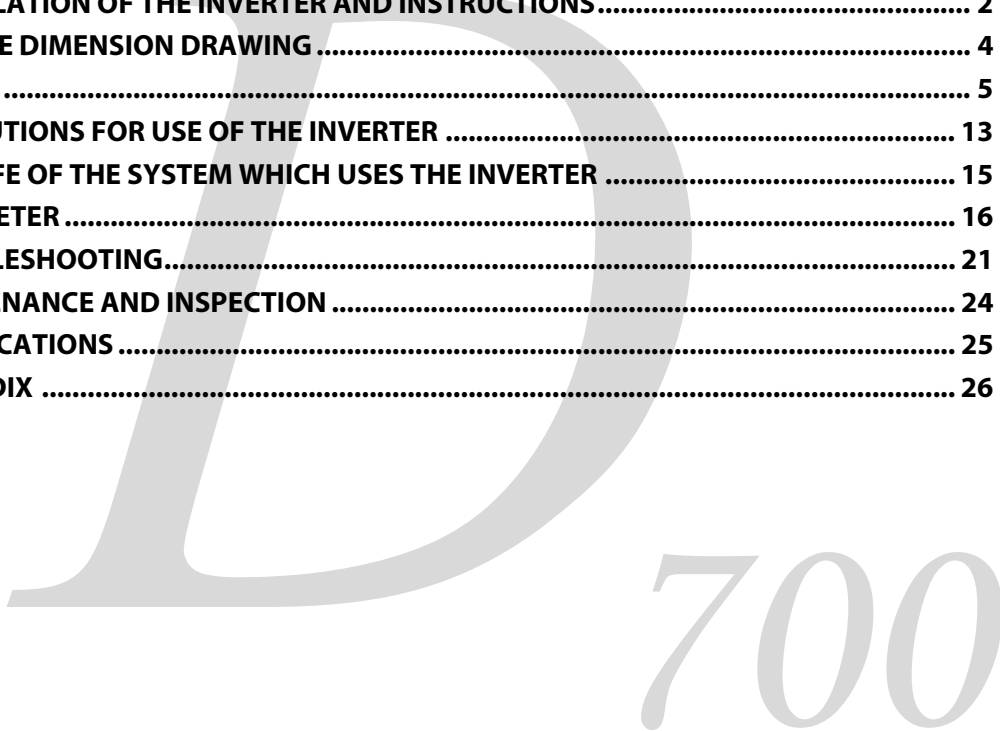

Print Date	Art. no.	Revision
02/2013 akl	260530-A	First edition

 **For Maximum Safety**

- Mitsubishi Electric transistorized inverters are not designed or manufactured to be used in equipment or systems in situations that can affect or endanger human life.
- When considering this product for operation in special applications such as machinery or systems used in passenger transportation, medical, aerospace, atomic power, electric power, or submarine repeating applications, please contact your nearest Mitsubishi Electric sales representative.
- Although this product was manufactured under conditions of strict quality control, you are strongly advised to install safety devices to prevent serious accidents when it is used in facilities where breakdowns of the product are likely to cause a serious accident.
- Please do not use this product for loads other than three-phase induction motors.
- Please check upon receiving of the inverter whether this instruction manual corresponds to the delivered inverter. Compare the specifications on the capacity plate with the specifications given in this manual.

## 1 About this Document

This document is the original mounting instruction.

### 1.1 Documentations for the FR-D700 SC Inverter

These manuals describe the mounting of the FR-D700 SC frequency inverter.

Mounting of any additional options is described in separated manuals. The installation, configuration and commissioning of the FR-D700 SC inverter is described in the "Inverter FR-D700 SC Instruction Manual". This document provides guidance on the safe use of the FR-D700 SC. Detailed technical information not included here can be found in manuals referred to in this document. These can be obtained free of charge from our website at [www.mitsubishi-automation.com](http://www.mitsubishi-automation.com).

The following manuals contain further information about the inverter:

- Inverter FR-D700 SC Instruction Manual,
- Transistorized Inverter FR-D700 SC Safety stop function Instruction Manual,
- Beginner's Manual of the Frequency Inverters FR-D700, FR-E700, FR-F700, and FR-A700,
- Manual for Frequency Inverters and EMC.

In addition mounting protective devices also requires specific technical skills which are not detailed in this documentation.

### 1.2 Function of this Document

These manuals instruct the technical staff of the machine manufacturer and/or of the machine operator on the safe mounting of the FR-D700 SC inverter.

These manuals do not provide manuals for operating the machine in which the safety control system is, or will be, integrated. Information of this kind will be found in the operating manuals for the machine.

## 2 Safety Instructions

Do not attempt to install, operate, maintain or inspect the inverter until you have read through this Installation Guideline and appended documents carefully and can use the equipment correctly. Do not use the inverter until you have a full knowledge of the equipment, safety information and instructions. In this Installation Guideline, the safety instruction levels are classified into "DANGER" and "CAUTION".



**DANGER**

Personnel health and injury warnings.

Failure to observe the precautions described here can result in serious health and injury hazards.



**CAUTION**

Equipment and property damage warnings.

Failure to observe the precautions described here can result in serious damage to the equipment or other property.

Note that even the **CAUTION** level may lead to a serious consequence according to conditions. Please follow strictly the instructions of both levels because they are important to personnel safety.

### 2.1 Safety Persons

The FR-D700 SC inverter may only be mounted by safety persons. Safety persons are defined as persons who ...

- ...have undergone the appropriate technical training. Please note appropriate technical training is available from your local Mitsubishi Electric office.  
Please contact your local office for locations and schedules.
- ...have been instructed by the responsible machine operator in the operation of the machine and the current valid safety guidelines and
- ...have access to the operating manuals of the FR-D700 SC inverter and have read and familiarised themselves with them and
- ...have access to the operating manuals for the protective devices (e. g. light curtain) connected to the safety control system and have read and familiarised themselves with them.

### 2.2 Applications of the Device

The FR-D700 SC is a variable speed drive, which can be used in safety installations.

The FR-D700 SC series inverter includes the safety functionality "Safe Torque Off", which can be used in accordance with ISO13849-1/EN954-1 Category 3 IEC60204-1 Stop category 0.

For any use in safety installation we refer to the "Transistorized Inverter FR-D700 SC Safety stop function Instruction Manual".

The degree of safety actually attained depends on the external circuit, the realisation of the wiring, the parameter configuration, the choice of the pick-ups and their location at the machine. Opto-electronic and tactile safety sensors (e. g. light curtains, laser scanners, safety switches, sensors, emergency-stop buttons) are connected to the modular safety control system and are linked logically. The corresponding actuators of the machines or systems can be switched off safely via the switching outputs of the safety control system.

### 2.3 Correct Use

The FR-D700 SC inverter may only be used within specific operating limits (voltage, temperature, etc., refer to the technical data and to the name plate on the device). It may only be used by specialist personnel and only at the machine at which it was mounted and initially commissioned by specialist personnel in accordance with the "Inverter FR-D700 SC Instruction Manual" and "Transistorized Inverter FR-D700 SC Safety stop function Instruction Manual".

Mitsubishi Electric Co. accepts no claims for liability if the equipment is used in any other way or if modifications are made to the device, even in the context of mounting and installation.



**DANGER**

The bus capacitor discharge time is 10 minutes. Before starting wiring or inspection, switch power off, wait for more than 10 minutes, and check for residual voltage between terminal P/+ and N/- with a meter etc., to avoid a hazard of electrical shock.

### 3 General Protective Notes and Protective Measures

Observe the protective notes and measures!

Please observe the following items in order to ensure proper use of the FR-D700 SC inverter.

- When mounting, installing and using the FR-D700 SC inverter, observe the standards and directives applicable in your country.
- The national rules and regulations apply to the installation, use and periodic technical inspection of the FR-D700 SC, in particular:
  - Machinery Directive 98/37/EC (from 29.12.2009 Machinery Directive 2006/42/EC),
  - EMC Directive 2004/108/EC,
  - Provision and Use of Work Equipment Directive 89/655/EC,
  - Low-Voltage Directive 2006/95/EC,
  - Work safety regulations/safety rules.
- Manufacturers and owners of the machine on which a FR-D700 SC inverter is used are responsible for obtaining and observing all applicable safety regulations and rules.
- It is imperative that the notices, in particular the test notices of the manuals be observed.
- The tests must be carried out by specialised personnel or specially qualified and authorised personnel and must be recorded and documented to ensure that the tests can be reconstructed and retraced at any time by third parties.

#### 3.1 Electric Shock Prevention

##### DANGER

- While power is ON or when the inverter is running, do not open the front cover or wiring cover. Otherwise you may get an electric shock.
- Do not run the inverter with the front cover removed. Otherwise you may access the exposed high-voltage terminals or the charging part of the circuitry and get an electric shock.
- Even if power is OFF, do not remove the front cover except for wiring or periodic inspection. You may access the charged inverter circuits and get an electric shock.
- Before starting wiring or inspection, check to make sure that the operation panel indicator is OFF, wait for at least 10 minutes after the power supply has been switched off, and check that there are no residual voltage using a tester or the like. The capacitor is charged with high voltage for some time after power OFF and it is dangerous.
- This inverter must be earthed (grounded). Earthing (Grounding) must conform to the requirements of national and local safety regulations and electrical codes. (NEC section 250, IEC 536 class 1 and other applicable standards)  
Use a neutral-point earthed (grounded) power supply for 400 V class inverter in compliance with EN standard.
- Any person who is involved in the wiring or inspection of this equipment should be fully competent to do the work.
- Always install the inverter before wiring. Otherwise you may get an electric shock or be injured.
- If your application requires by installation standards an RCD (residual current device) as up stream protection please select according to DIN VDE 0100-530 as following:  
Single phase inverter type A or B  
Three phase inverter only type B  
(Additional instructions on the use of a residual current device are contained on *page 27*.)
- Perform setting dial and key operations with dry hands to prevent an electric shock. Otherwise you may get an electric shock.
- Do not subject the cables to scratches, excessive stress, heavy loads or pinching. Otherwise you may get an electric shock.
- Do not replace the cooling fan while power is on. It is dangerous to replace the cooling fan while power is on.
- Do not touch the printed circuit board or handle the cables with wet hands. You may get an electric shock.
- When measuring the main circuit capacitor capacity, the DC voltage is applied to the motor for 1 s at powering off. Never touch the motor terminal, etc. right after powering off to prevent an electric shock.

#### 3.2 Fire Prevention

##### CAUTION

- Install the inverter on a nonflammable wall without holes (so that nobody can touch the inverter heatsink on the rear side, etc.). Mounting it to or near flammable material can cause a fire.
- If the inverter has become faulty, switch off the inverter power. A continuous flow of large current could cause a fire.
- When using a brake resistor, make up a sequence that will turn off power when an alarm signal is output. Otherwise, the brake resistor may excessively overheat due to damage of the brake transistor and such, causing a fire.
- Do not connect a resistor directly to the DC terminals P/+, N/-. This could cause a fire and destroy the inverter. The surface temperature of braking resistors can far exceed 100 °C for brief periods. Make sure that there is adequate protection against accidental contact and a safe distance is maintained to other units and system parts.

#### 3.3 Injury Prevention

##### CAUTION

- Apply only the voltage specified in the instruction manual to each terminal. Otherwise, burst, damage, etc. may occur.
- Ensure that the cables are connected to the correct terminals. Otherwise, burst, damage, etc. may occur.
- Always make sure that polarity is correct to prevent damage, etc. Otherwise, burst, damage, etc. may occur.
- While power is on or for some time after power-off, do not touch the inverter as it is hot and you may get burnt.

#### 4 Additional Instructions

Also note the following points to prevent an accidental failure, injury, electric shock, etc.

##### 4.1 Transportation and Installation

### ⚠ CAUTION

- Transport the product using the correct method that corresponds to the weight. Failure to observe this could lead to injuries.
- Do not stack the inverter boxes higher than the number recommended.
- Ensure that installation position and material can withstand the weight of the inverter. Install according to the information in the instruction manual.
- Do not install or operate the inverter if it is damaged or has parts missing. This can result in breakdowns.
- When carrying the inverter, do not hold it by the front cover or setting dial; it may fall off or fail.
- Do not stand or rest heavy objects on the product.
- Check the inverter mounting orientation is correct.
- Prevent other conductive bodies such as screws and metal fragments or other flammable substance such as oil from entering the inverter.
- As the inverter is a precision instrument, do not drop or subject it to impact.
- Use the inverter under the following environmental conditions. Otherwise, the inverter may be damaged.

Operating Condition	Ambient temperature	-10 °C to +50 °C (non-freezing)
	Ambient humidity	90 % RH or less (non-condensing)
	Storage temperature	-20 °C to +65 °C <sup>①</sup>
	Atmosphere	Indoors (free from corrosive gas, flammable gas, oil mist, dust and dirt)
	Altitude	Maximum 1000m above sea level for standard operation. After that derate by 3 % for every extra 500 m up to 2500 m (91 %)
	Vibration	5.9 m/s <sup>2</sup> or less at 10 to 55 Hz (directions of X, Y, Z axes)

<sup>①</sup> Temperature applicable for a short time, e.g. in transit.

##### 4.2 Wiring

### ⚠ CAUTION

- Do not install assemblies or components (e. g. power factor correction capacitors) on the inverter output side, which are not approved from Mitsubishi Electric.
- The direction of rotation of the motor corresponds to the direction of rotation commands (STF/STR) only if the phase sequence (U, V, W) is maintained.

##### 4.3 Test Operation and Adjustment

### ⚠ CAUTION

- Before starting operation, confirm and adjust the parameters. A failure to do so may cause some machines to make unexpected motions.

##### 4.4 Operation

### ⚠ DANGER

- When you have chosen the retry function, stay away from the equipment as it will restart suddenly after an alarm stop.
- Since pressing  key may not stop output depending on the function setting status, provide a circuit and switch separately to make an emergency stop (power off, mechanical brake operation for emergency stop, etc).
- Make sure that the start signal is off before resetting the inverter alarm. A failure to do so may restart the motor suddenly.
- The inverter can be started and stopped via the serial port communications link or the field bus. However, please note that depending on the settings of the communications parameters it may not be possible to stop the system via these connections if there is an error in the communications system or the data line. In configurations like this it is thus essential to install additional safety hardware that makes it possible to stop the system in an emergency (e.g. controller inhibit via control signal, external motor contactor etc). Clear and unambiguous warnings about this must be posted on site for the operating and service staff.
- The load used should be a three-phase induction motor only. Connection of any other electrical equipment to the inverter output may damage the inverter as well as the equipment.
- Do not modify the equipment.
- Do not perform parts removal which is not instructed in this manual. Doing so may lead to fault or damage of the inverter.

### **⚠ CAUTION**

- The electronic thermal relay function does not guarantee protection of the motor from overheating. It is recommended to install both an external thermal and PTC thermistor for overheat protection.
- Do not use a magnetic contactor on the inverter input for frequent starting/stopping of the inverter. Otherwise, the life of the inverter decreases.
- Use a noise filter to reduce the effect of electromagnetic interference and follow the accepted EMC procedures for proper installation of frequency inverters. Otherwise nearby electronic equipment may be affected.
- Take appropriate measures regarding harmonics. Otherwise this can endanger compensation systems or overload generators.
- When a 400 V class motor is inverter-driven, please use an insulation-enhanced motor or measures taken to suppress surge voltages. Surge voltages attributable to the wiring constants may occur at the motor terminals, deteriorating the insulation of the motor.
- When parameter clear or all clear is performed, set again the required parameters before starting operations. Each parameter returns to the initial value.
- The inverter can be easily set for high-speed operation. Before changing its setting, fully examine the performances of the motor and machine.
- The DC braking function of the frequency inverter is not designed to continuously hold a load. Use an electro-mechanical holding brake on the motor for this purpose.
- Before running an inverter which had been stored for a long period, always perform inspection and test operation.
- For prevention of damage due to static electricity, touch nearby metal before touching this product to eliminate static electricity from your body.
- If you are installing the inverter to drive a three-phase device while you are contracted for lighting and power service, consult your electric power supplier.

#### **4.5 Emergency Stop**

### **⚠ CAUTION**

- Provide a safety backup such as an emergency brake which will prevent the machine and equipment from hazardous conditions if the inverter fails.
- When the breaker on the inverter primary side trips, check for the wiring fault (short circuit), damage to internal parts of the inverter, etc. Identify the cause of the trip, then remove the cause and power on the breaker.
- When the protective function is activated (i. e. the frequency inverter switches off with an error message), take the corresponding corrective action as described in the inverter manual, then reset the inverter, and resume operation.

#### **4.6 Maintenance, Inspection and Parts Replacement**

### **⚠ CAUTION**

- Do not carry out a megger (insulation resistance) test on the control circuit of the inverter. It will cause a failure.

It is recommended to make the following checks periodically:

- Check for loose screws in the terminal block. Retighten any loose screws.
- Check for dust accumulation on the inverter. Clean the heat sink and the cooling fan of the inverter.
- Check for unusual noise generated by the inverter. Retighten installation screw.
- Check for the operation condition. Keep the operation condition of inverter as written in the manual.

#### **4.7 Disposal of the Inverter**

### **⚠ CAUTION**

- Disposal of unusable or irreparable devices should always occur in accordance with the applicable country-specific waste-disposal regulations (e.g. European Waste Code 16 02 14).

### **5 General Instructions**

Many of the diagrams and drawings in instruction manuals show the inverter without a cover, or partially open. Never run the inverter in this status. Always replace the cover and follow instruction manuals when operating the inverter.

#### **NOTES**

- The FR-D700 SC complies to the EMC Directive 2004/108/EC and the relevant requirements of EN61800-3:2004 (Second environment/ PDS category "C3"). Therefore the FR-D700 SC is only suitable for use in an industrial environment and not for private use. If you want to use FR-D700 SC inverter in first environment you will have to add an external RFI filter.
- The FR-D700 SC complies to the Low Voltage Directive 2006 and the relevant requirements of EN61800-5-1:2007.

---

---

# 1 PRODUCT DESCRIPTION

---

---

## 1.1 FR-D700 SC Inverter

An FR-D700 SC frequency inverter is a device that converts the fixed voltage and frequency of the mains power supply into a variable voltage with a variable frequency. It is installed between the mains supply and the motor and makes continuously-variable speed adjustment possible.

The adjustable frequency AC drive generates the rotational energy of the motor, which in turn generates the torque of the motor. It controls induction motors for a variety of automation applications such as air conditioning, conveyor, washing machine, machine tools, lift machines, etc.

## 1.2 Operation Panel

---

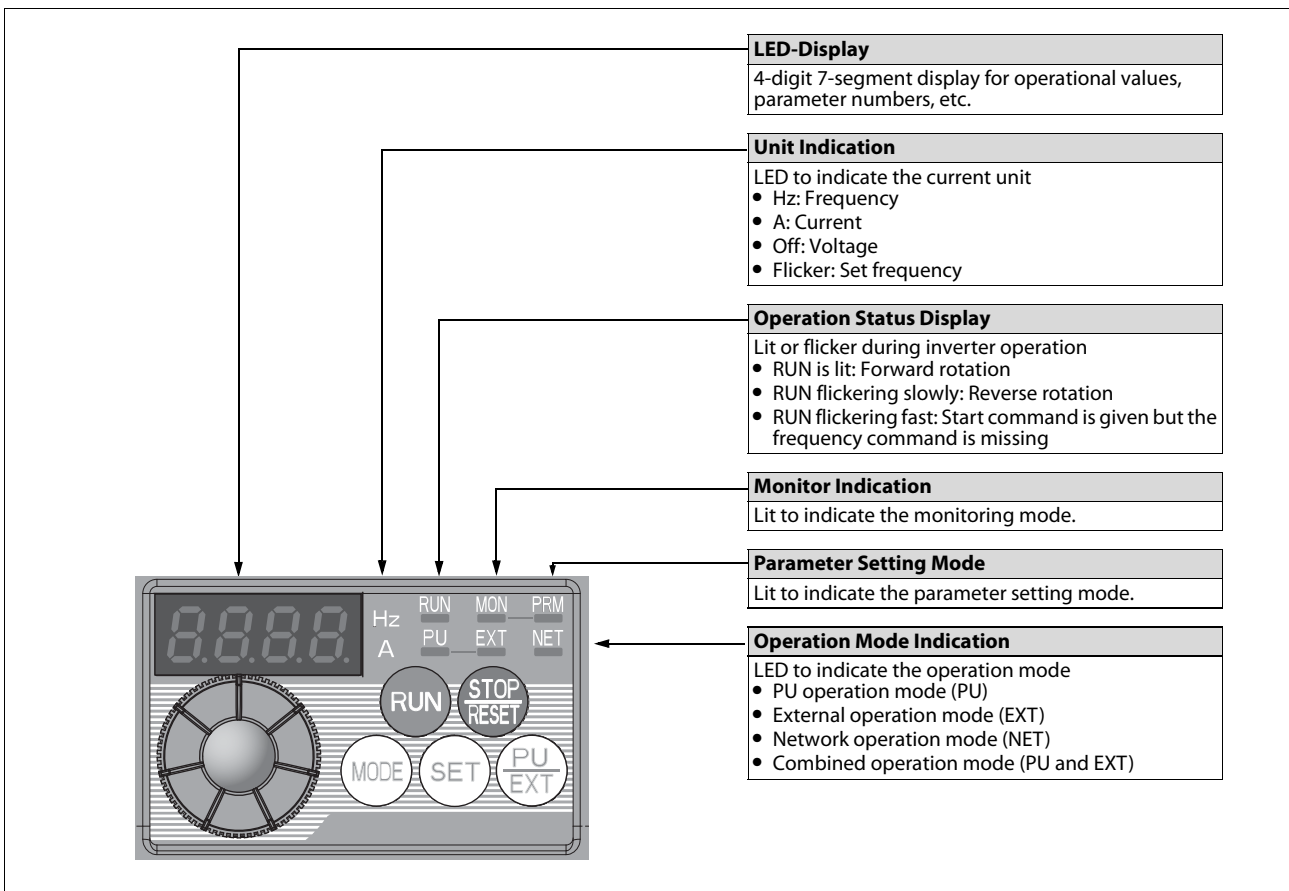

### NOTE

For detailed description of the operation panel please refer to the "Inverter FR-D700 SC Instruction Manual".

## 2 INSTALLATION OF THE INVERTER AND INSTRUCTIONS

Unpack the inverter and check the capacity plate on the front cover and the rating plate on the inverter side face to ensure that the product agrees with your order and the inverter is intact.

### 2.1 Inverter Type

FR - D740 - 036 SC - EC

Symbol	Voltage Class
D720S	Single-phase 200 V class
D740	Three-phase 400 V class

Symbol	Type Number
008 to 160	3-digit display

Symbol	Control Circuit Terminal Specification
SC	Source-logic safety stop function model

#### Capacity plate example

##### Capacity plate

**FR-D740-036SC-EC** ← Inverter type  
**SERIAL : XXXXXX** ← Serial number

##### Serial number description

A 0 X 123456

- Product ID and Lot
- Month of construction: 1 to 9 for Jan. to Sep., X to Z for Oct. to Dec.
- Last digit of year of construction: 0 for 2010 for example
- Alphabetical code of revision

#### Rating plate example

##### Rating plate

MITSUBISHI INVERTER  
**Inverter type** → MODEL FR-D740-036SC-EC  
**Input rating** → INPUT : XXXXX  
**Output rating** → OUTPUT : XXXXX  
**Serial number** → SERIAL : \_\_\_\_\_

PASSED

### 2.2 General Precaution

#### **⚠ DANGER**

The bus capacitor discharge time is 10 minutes. Before starting wiring or inspection, switch power off, wait for more than 10 minutes, and check for residual voltage between terminal P/+ and N/- with a meter etc., to avoid a hazard of electrical shock.

### 2.3 Environment

Before installation, check that the environment meets following specifications:

<b>Ambient temperature</b>	-10 °C to +50 °C (non-freezing)
<b>Ambient humidity</b>	90 % RH or less (non-condensing)
<b>Atmosphere</b>	Indoors (free from corrosive gas, flammable gas, oil mist, dust and dirt)
<b>Altitude</b>	Maximum 1000 m above sea level for standard operation. After that derate by 3 % for every extra 500 m up to 2500 m (91 %)
<b>Vibration</b>	5.9 m/s <sup>2</sup> or less at 10 to 55 Hz (directions of X, Y, Z axes)

#### **CAUTION**

- Install the inverter on a strong surface securely and vertically with bolts.
- Leave enough clearances and take cooling measures.
- Avoid places where the inverter is subjected to direct sunlight, high temperature and high humidity.
- Install the inverter on a non-combustible surface.



## 2.4 Installation of the Inverter

Enclosure surface mounting

Remove the front cover and wiring cover to fix the inverter to the surface.

FR-D720S-008SC to 042SC

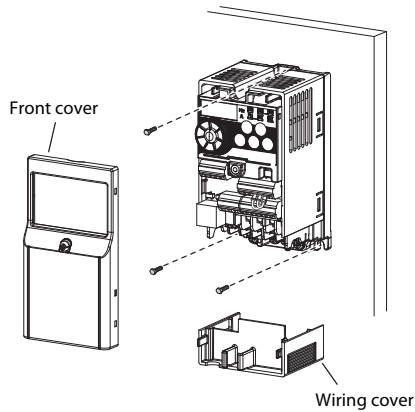

FR-D720S-070SC and 100SC, FR-D740-012SC to 160SC

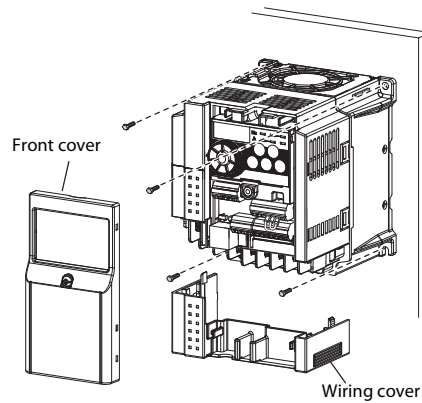

### NOTES

- When encasing multiple inverters, install them in parallel and leave clearance as a cooling measure.
- Install the inverter vertically.

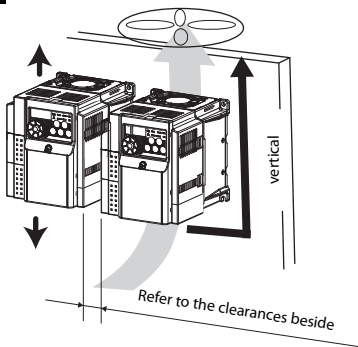

Ambient temperature and humidity

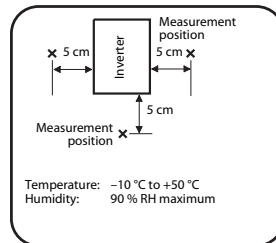

Leave enough clearances and take cooling measures.

Clearances (side)

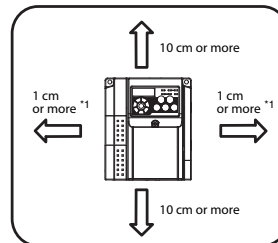

\*1 When using the inverters at the ambient temperature of 40 °C or less, the inverters can be installed closely attached (0 cm clearance). When ambient temperature exceeds 40 °C, clearances between the inverter should be 1 cm or more (5 cm or more for the FR-D740-120SC or more).

Clearances (front)

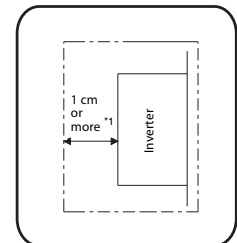

\*1 5 cm or more for the FR-D740-120SC or more

### 3 OUTLINE DIMENSION DRAWING

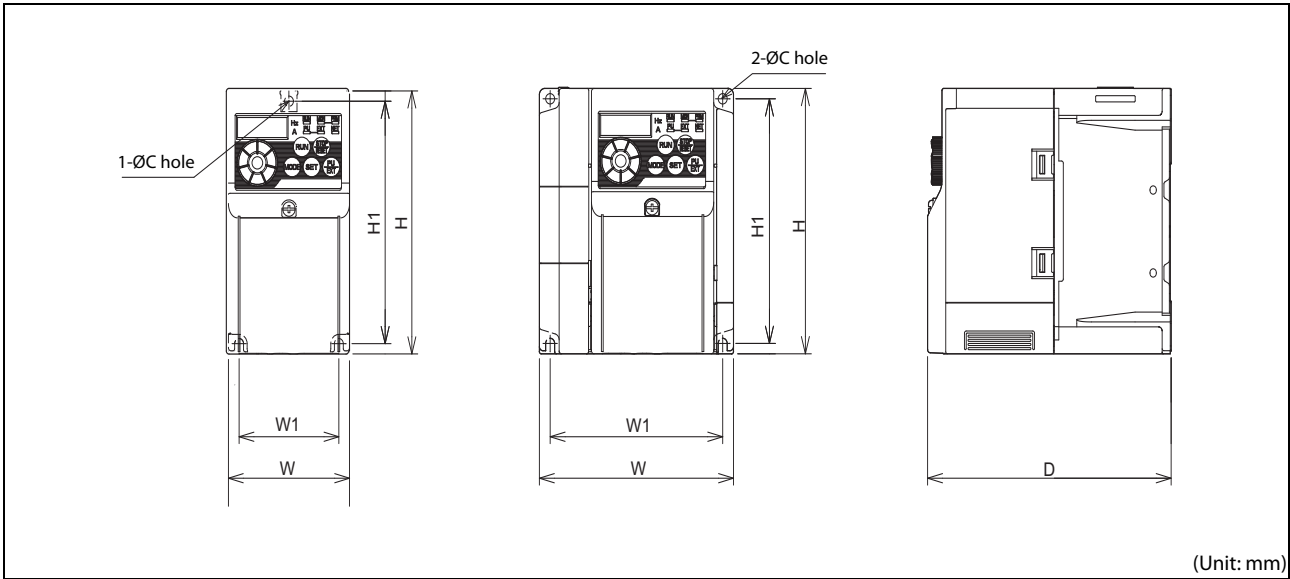

Inverter Type		W	W1	H	H1	D	C
200 V class	FR-D720S-008SC	68	56	128	118	80.5	5
	FR-D720S-014SC					142.5	
	FR-D720S-025SC					162.5	
	FR-D720S-042SC					155.5	
	FR-D720S-070SC	108	96	150	138	145	
	FR-D720S-100SC	140	128			129.5	
400 V class	FR-D740-012SC	108	96	128	118	135.5	
	FR-D740-022SC					155.5	
	FR-D740-036SC					165.5	
	FR-D740-050SC					155	
	FR-D740-080SC						
	FR-D740-120SC	220	208	150	138	155	
	FR-D740-160SC						

# 4 WIRING

## 4.1 Terminal Connection Diagram

Source logic

- ⊙ Main circuit terminal
- Control circuit terminal

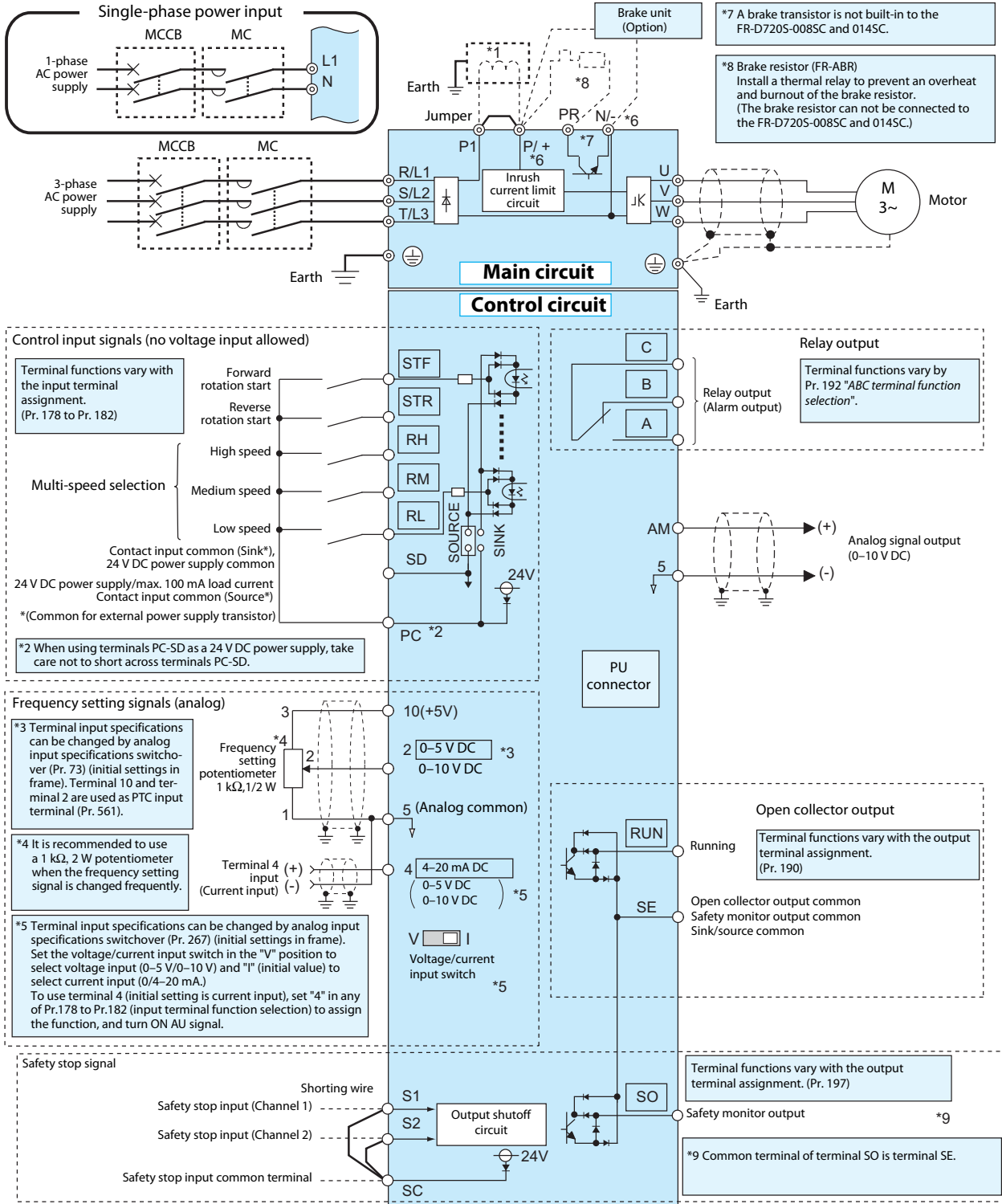



**CAUTION**

- To prevent a malfunction due to noise, keep the signal cables more than 10 cm away from the power cables. Also separate the main circuit wire of the input side and the output side.
- After wiring, wire offcuts must not be left in the inverter.  
Wire offcuts can cause an alarm, failure or malfunction. Always keep the inverter clean. When drilling mounting holes in a control box etc., take care not to allow chips and other foreign matter to enter the inverter.
- Set the voltage/current input switch in the correct position. An incorrect setting may cause a fault, failure or malfunction.
- The output of the single-phase power input specification is three-phase 230 V.

**4.2 Main Circuit Terminal Specifications**

**4.2.1 Terminal Arrangement of the Main Circuit Terminal, Power Supply and the Motor Wiring**

**Single-Phase 200 V Class**

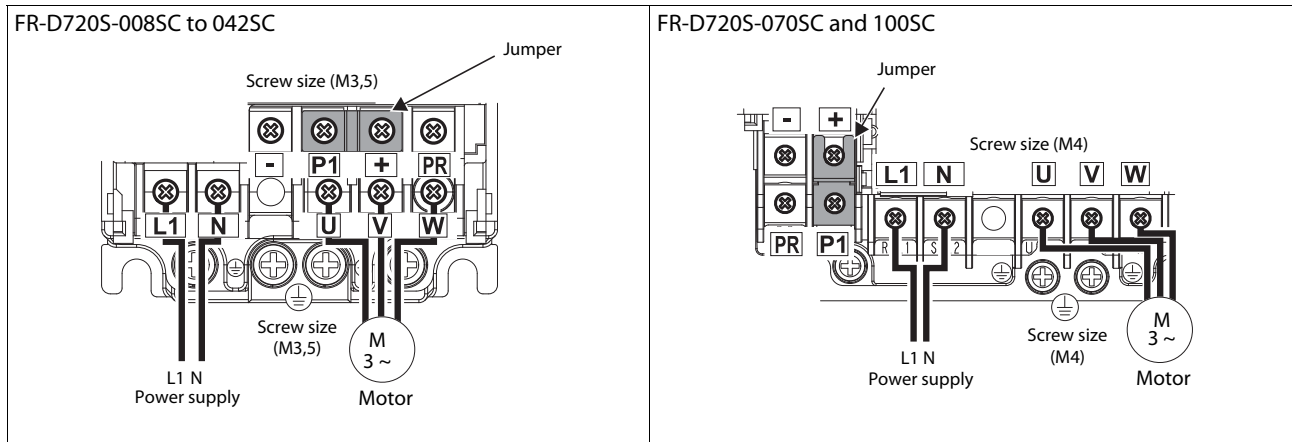

**Three-Phase 400 V Class**

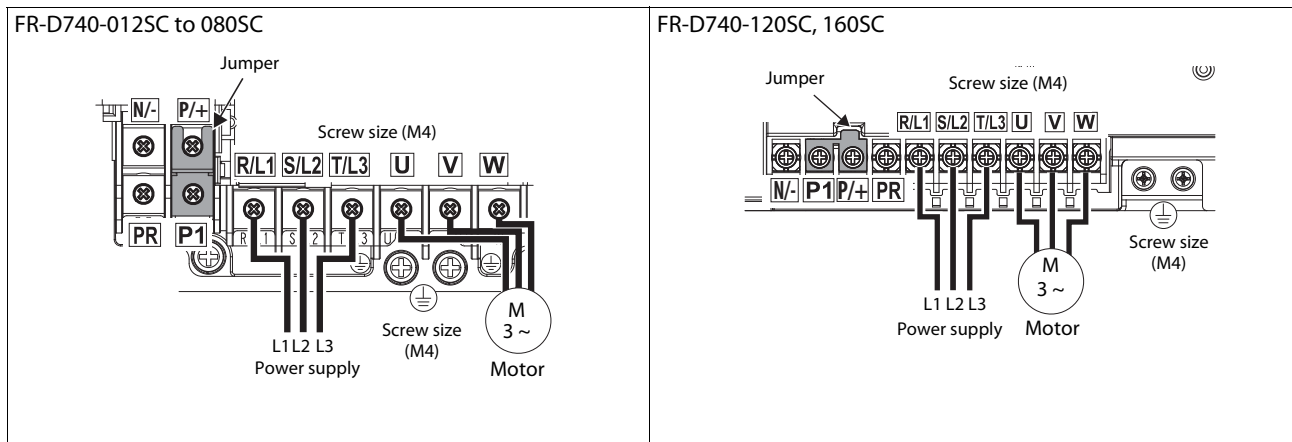

**CAUTION**

- Make sure the power cables are connected to the R/L1, S/L2, T/L3 (three-phase 400 V class) resp. to the L1, N (for single-phase 200 V class). Never connect the power cable to the U, V, W of the inverter. Doing so will damaged the inverter. (Phase sequence needs not to be matched.)
- Connect the motor to U, V, W. At this time turning on the forward rotation switch (signal) rotates the motor in the clockwise direction when viewed on the motor shaft.

## 4.3 Cables and Wiring Length

### 4.3.1 Cable Size

Select the recommended cable size to ensure that a voltage drop will be 2 % max.

If the wiring distance is long between the inverter and motor, a main circuit cable voltage drop will cause the motor torque to decrease especially at the output of a low frequency.

The following tables indicate a selection example for the wiring length of 20 m.

#### Single-phase 200 V class (when input power supply is 220 V)

Applicable Inverter Type	Terminal Screw Size *4	Tightening Torque [Nm]	Crimping Terminal	
			L1, N, P1, +	U, V, W
FR-D720S-008SC to 042SC	M3.5	1.2	2-3.5	2-3.5
FR-D720S-070SC	M4	1.5	2-4	2-4
FR-D720S-100SC	M4	1.5	5.5-4	2-4

Applicable Inverter Type	Cable Sizes							
	HIV [mm <sup>2</sup> ] *1			AWG *2		PVC [mm <sup>2</sup> ] *3		
	L1, N, P1, +	U, V, W	Earth Cable Gauge	L1, N, P1, +	U, V, W	L1, N, P1, +	U, V, W	Earth Cable Gauge
FR-D720S-008SC to 042SC	2	2	2	14	14	2.5	2.5	2.5
FR-D720S-070SC	2	2	2	14	14	2.5	2.5	2.5
FR-D720S-100SC	3.5	2	3.5	12	14	4	2.5	4

#### Three-phase 400 V class (when input power supply is 440 V)

Applicable Inverter Type	Terminal Screw Size *4	Tightening Torque [Nm]	Crimping Terminal	
			R/L1, S/L2, T/L3, P/1, P/+	U, V, W
FR-D740-012SC to 080SC	M4	1.5	2-4	2-4
FR-D740-120SC	M4	1.5	5.5-4	2-4
FR-D740-160SC	M4	1.5	5.5-4	5.5-4

Applicable Inverter Type	Cable Sizes							
	HIV [mm <sup>2</sup> ] *1			AWG *2		PVC [mm <sup>2</sup> ] *3		
	R/L1, S/L2, T/L3, P/1, P/+	U, V, W	Earth Cable Gauge	R/L1, S/L2, T/L3, P/1, P/+	U, V, W	R/L1, S/L2, T/L3, P/1, P/+	U, V, W	Earth Cable Gauge
FR-D740-012SC to 080SC	2	2	2	14	14	2.5	2.5	2.5
FR-D740-120SC	3.5	2	3.5	12	14	4	2.5	4
FR-D740-160SC	3.5	3.5	3.5	12	12	4	4	4

\*1 The recommended cable size is that of the HIV cable (600 V class 2 vinyl-insulated cable) with continuous maximum permissible temperature of 75 °C. Assumes that the ambient temperature is 50 °C or less and the wiring distance is 20 m or less.

\*2 The recommended cable size is that of the THHW cable with continuous maximum permissible temperature of 75 °C. Assumes that the ambient temperature is 40 °C or less and the wiring distance is 20 m or less.  
(Selection example for use mainly in the United States.)

\*3 The recommended cable size is that of the PVC cable with continuous maximum permissible temperature of 70 °C. Assumes that the ambient temperature is 40 °C or less and the wiring distance is 20 m or less.  
(Selection example for use mainly in Europe.)

\*4 The terminal screw size indicates the terminal size for R/L1, S/L2, T/L3, U, V, W, PR, P/+, N/-, P1 and a screw for earthing.  
For single-phase power input, the terminal screw size indicates the size of terminal screw for L1, N, U, V, W, PR, +, -, P1 and a screw for earthing (grounding).

### CAUTION

- Tighten the terminal screw to the specified torque. A screw that has been tightened too loosely can cause a short circuit or malfunction. A screw that has been tightened too tightly can cause a short circuit or malfunction due to the unit breakage.
- Use crimping terminals with insulation sleeve to wire the power supply and motor.

The line voltage drop can be calculated by the following expression:

$$\text{Line voltage drop [V]} = \frac{\sqrt{3} \times \text{wire resistance [m}\Omega/\text{m}] \times \text{wiring distance [m]} \times \text{current [A]}}{1000}$$

Use a larger diameter cable when the wiring distance is long or when it is desired to decrease the voltage drop (torque reduction) in the low speed range.



### 4.3.2 Maximum Permissible Motor Wiring Length

The maximum permissible length of the motor cables depends on the capacity of the inverter and the selected carrier frequency. The lengths in the following table are for unshielded cables. When shielded cables are used divide the values listed in the table by 2. Note that the values are for the total wiring length – if you connect more than one motor in parallel you must add the lengths of the individual motor cables.

#### Single-phase 200 V class

Setting of Pr. 72 PWM Frequency selection (Carrier Frequency)	FR-D720S-				
	008SC	014SC	025SC	042SC	≥ 070SC
1 (1 kHz) or less	200 m	200 m	300 m	500 m	500 m
2 to 15 (2 kHz to 14.5 kHz)	30 m	100 m	200 m	300 m	500 m

#### Three-phase 400 V class

Setting of Pr. 72 PWM Frequency selection (Carrier Frequency)	FR-D740-				
	012SC	022SC	036SC	050SC	≥ 080SC
1 (1 kHz) or less	200 m	200 m	300 m	500 m	500 m
2 to 15 (2 kHz to 14.5 kHz)	30 m	100 m	200 m	300 m	500 m

Total wiring length (FR-D720S-070SC or more, FR-D740-080SC or more)

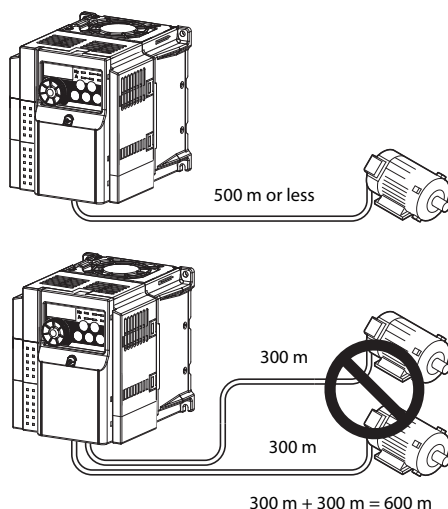

Note that the motor windings in three-phase AC motors are subject to far more stress when operated via frequency inverters than with mains operation. The motor must have been approved by the manufacturer for operation on a frequency inverter.

In the PWM type inverter, a surge voltage attributable to wiring constants is generated at the motor terminals. Especially for a 400 V class motor, the surge voltage may deteriorate the insulation. When the 400 V class motor is driven by the inverter, consider the following measures:

- Use a "400 V class inverter-driven insulation-enhanced motor" and set frequency in Pr. 72 PWM frequency selection according to wiring length.

	Wiring Length		
	≤ 50 m	50 m–100 m	≥ 100 m
Carrier frequency	≤ 14.5 kHz	≤ 8 kHz	≤ 2 kHz

- Limiting the voltage rise speed of the frequency inverter output voltage (dV/dT):  
If the motor requires a rise speed of 500 V/μs or less you must install a filter in the output of the inverter. Please contact your Mitsubishi Electric dealer for more details.

#### CAUTION

- Especially for long-distance wiring (particularly when employing shielded motor cables), the inverter may be affected by a charging current caused by the stray capacitances of the wiring, leading to a malfunction of the overcurrent protective function or fast response current limit function, or stall prevention function or a malfunction or fault of the equipment connected on the inverter output side.  
When the fast-response current limit function malfunctions, make the function invalid. When stall prevention function misoperates, increase the stall level. (For Pr. 22 Stall prevention operation level and Pr. 156 Stall prevention operation selection, refer to the Instruction Manual.)
- For details of Pr. 72 PWM frequency selection, refer to the Instruction Manual.
- When using the automatic restart after instantaneous power failure function with wiring length exceeding below, select without frequency search (Pr. 162 = "1", "11"). (Refer to the instruction manual for further information to Pr. 162).

Motor capacity	0.1 K	0.2 K	≥ 0.4 K
Wiring length	20 m	50 m	100 m

## 4.4 Control Circuit Specification

### 4.4.1 Terminal Assignment

Input Signal		
Type	Terminal	Name
Contact input	STF	Forward rotation start
	STR	Reverse rotation start
	RH, RM, RL	Multi-speed selection
Reference point	SD	Contact input common (sink), 24 V DC power supply common
	PC	24 V DC power supply, contact input common (source)
Frequency setting	10	Frequency setting power supply
	2	Frequency setting (voltage)
	4	Frequency setting (current)
	5	Frequency setting common

Communication		
Type	Terminal	Name
RS485	—	PU connector

Output Signal		
Type	Terminal	Name
Relay	A, B, C	Relay output (alarm output)
Open collector	RUN	Inverter running
	SE	Open collector output common Safety monitor output common
Analog output	AM	Analog voltage output

Safety Stop Signal	
Terminal	Name
S1	Safety stop input (Channel 1)
S2	Safety stop input (Channel 2)
S0	Safety monitor output (Open collector output)
SC	Safety stop input terminal common

**NOTE**

For detailed description and reference on any input or output signal refer to the "Inverter FR-D700 SC Instruction Manual" and the "Transistorized Inverter FR-D700 SC Safety stop function Instruction Manual".

### 4.4.2 Control Circuit Terminal Layout

Recommended wire size:  
0.3mm<sup>2</sup> to 0.75mm<sup>2</sup>

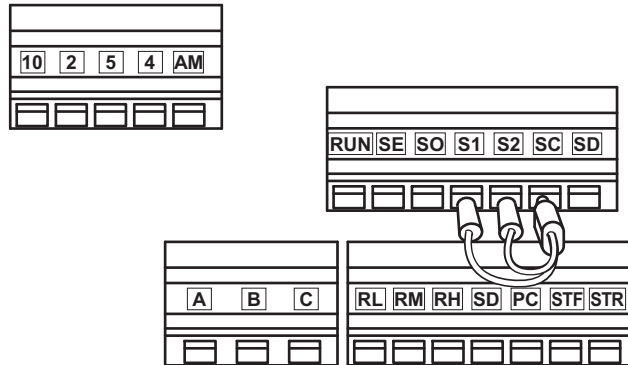



### 4.4.3 Wiring Method

Use a bar terminal and a cable with a sheath stripped off for the control circuit wiring. For a single wire, strip off the sheath of the cable and apply directly. Insert the bar terminal or the single wire into a socket of the terminal.

- Strip off the sheath about the length below. Wire the stripped cable after twisting it to prevent it from becoming loose. In addition, do not solder it.

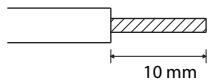

- Crimp the bar terminal. Insert wires to a bar terminal, and check that the wires come out for about 0 to 0.5 mm from a sleeve.

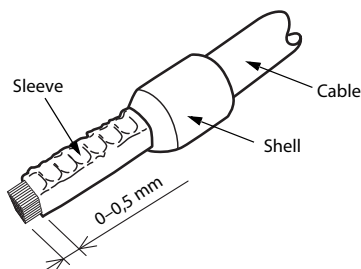

- Check the condition of the bar terminal after crimping. Do not use a bar terminal of which the crimping is inappropriate, or the face is damaged.

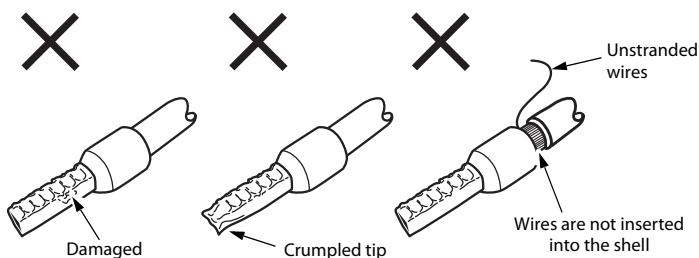

- Introduced products on bar terminals:

Wire Size [mm <sup>2</sup> ]	Bar Terminal Model			Bar Terminal Crimping Tool
	With Insulation Sleeve	Without Insulation Sleeve	For UL Wire *1	
0.3	AI 0,5-10WH	—	—	CRIMPFOX 6 (Phoenix Contact Co., Ltd.)
0.5			AI 0,5-10WH-GB	
0.75	AI 0,75-10GY	A 0,75-10	AI 0,75-10GY-GB	
1	AI 1-10RD	A 1-10	AI 1-10RD/1000GB	
1.25/1.5	AI 1,5-10BK	A 1,5-10	AI 1,5-10BK/1000GB *2	
0.75 (for two cables)	AI-TWIN 2 × 0,75-10GY	—	—	

\*1 A bar terminal with an insulation sleeve compatible with MTW wire which has a thick wire insulation

\*2 Applicable for terminal ABC

Wire Size [mm <sup>2</sup> ]	Bar Terminal Product Number	Insulation Product Number	Bar Terminal Crimping Tool
0.3 to 0.75	BT 0.75-11	VC 0.75	NH 67 (NICHIFU Co., Ltd.)



- Insert the wire into a socket.

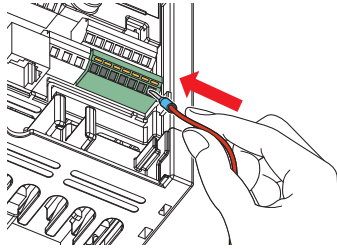

When using a single wire or a stranded wire without a bar terminal, push an open/close button all the way down with a flathead screwdriver, and insert the wire.

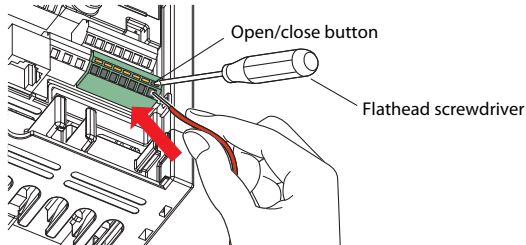

### CAUTION

- When using a stranded wire without a bar terminal, twist enough to avoid short circuit with a nearby terminals or wires.
- Place the flathead screwdriver vertical to the open/close button. In case the blade tip slips, it may cause to damage of inverter or injury.

### Wire removal

- Pull the wire with pushing the open/close button all the way down firmly with a flathead screwdriver.

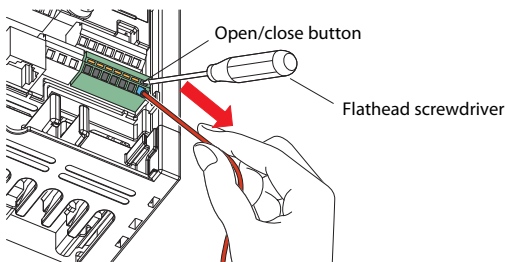

### CAUTION

- Use a small flathead screwdriver (Tip thickness: 0.4 mm/tip width: 2.5 mm, such as SZF 0-0,4x2,5 (Phoenix Contact Co., Ltd.)). If a flathead screwdriver with a narrow tip is used, terminal block may be damaged.
- Place the flathead screwdriver vertical to the open/close button. In case the blade tip slips, it may cause to damage of inverter or injury.

## 4.4.4 Wiring Instructions

- Terminals PC, 5, and SE are all common terminals (0 V) for I/O signals and are isolated from each other. Avoid connecting the terminal PC and 5 and the terminal SE and 5 (ground). Terminal PC is a common terminal for the contact input terminals (STF, STR, RH, RM and RL).
- Use shielded or twisted cables for connection to the control circuit terminals and run them away from the main and power circuits (including the 230 V relay sequence circuit).
- Use two or more parallel micro-signal contacts or twin contacts to prevent a contact faults when using contact inputs since the control circuit input signals are micro-currents.
- Do not apply a voltage to the contact input terminals (e. g. STF) of the control circuit.
- Always apply a voltage to the alarm output terminals (A, B, C) via a relay coil, lamp, etc. In no way must a voltage be short-circuited by these relay contacts.
- It is recommended to use the cables of 0.3mm<sup>2</sup> to 0.75mm<sup>2</sup> gauge for connection to the control circuit terminals. The wiring length should be 30 m maximum.
- The level of the control signals can be switched over between positive (SOURCE) and negative (SINK) logic. The input signals are set to source logic when shipped from the factory. To change the control logic, the jumper connector above the control circuit terminal block must be removed to the other position.
- Do not short terminal PC and SD. Inverter may be damaged.

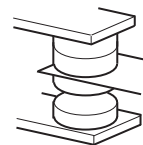

Micro signal contacts

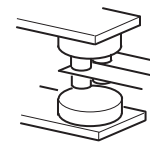

Twin contacts



### 4.4.5 Safety Stop Function

#### Connection Diagram for Intended Use

This diagram shows the example connection diagram for intended use.

The safety relay module is necessary for the generating redundant safe stop signals which are connected to the S1 and S2 terminal of FR-D700 SC.

To prevent restarting when the failure detected, output terminal of FR-D700 SC, RUN-SE as example in diagram, must be inserted into reset circuit of safety relay module to disable the RESET button operation.

For detailed configuration please refer to the Instruction manual and the "Transistorized Inverter FR-D700 SC Safety stop function Instruction Manual".

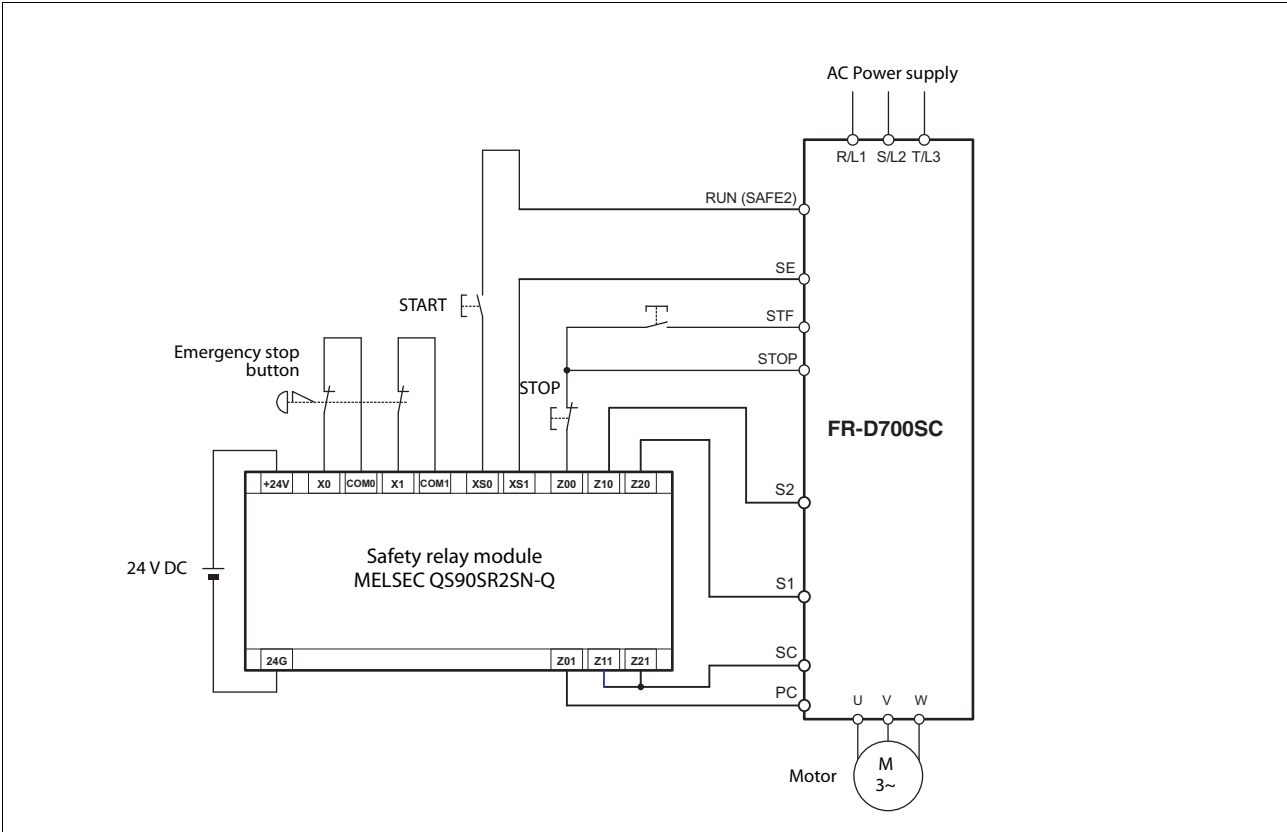

#### ⚠ CAUTION

- Ensure the safety relay module and the D700 SC unit is mounted closely in enclosure meeting IP54 and all interconnection wiring is short and protected against open and short circuit faults. Refer to ISO/IEC13849-2.
- The approved safety relay module to ISO13849-1/EN954-1 safety category 3 or better shall be used in conjunction with FR-D700 SC as shown in example. In addition, all other components with in the safety stop loop shall be "safety approved" types.

- Combination availability when using the safety stop function

Inverter Model (Safety stop terminal logic)	FR-D700 EC (sink logic)	FR-D700 SC EC (source logic)	FR-E700 SC EC (source logic)
FR-D700 EC (sink logic)	✓	—	—
FR-D700 SC EC (source logic)	—	✓	✓
FR-E700 SC EC (source logic)	—	✓	✓

---

---

## 5 PRECAUTIONS FOR USE OF THE INVERTER

---

---

The FR-D700 SC series is a highly reliable product, but incorrect peripheral circuit making or operation/handling method may shorten the product life or damage the product.

Before starting operation, always recheck the following items.

- Use crimping terminals with insulation sleeve to wire the power supply and motor.
- Application of power to the output terminals (U, V, W) of the inverter will damage the inverter. Never perform such wiring.
- After wiring, wire offcuts must not be left in the inverter.  
Wire offcuts can cause an alarm, failure or malfunction. Always keep the inverter clean. When drilling mounting holes in a control box etc., take care not to allow chips and other foreign matter to enter the inverter.
- Use cables of the size to make a voltage drop 2 % maximum.  
If the wiring distance is long between the inverter and motor, a main circuit cable voltage drop will cause the motor torque to decrease especially at the output of a low frequency.  
Refer to *page 7* for the recommended cable size.
- The overall wiring length should be within the prescribed length.  
Especially for long distance wiring, the fast-response current limit function may be reduced or the equipment connected to the inverter output side may malfunction or become faulty under the influence of a charging current due to the stray capacity of the wiring. Therefore, note the overall wiring length. (Refer to *page 8*)
- Electromagnetic Compatibility  
Operation of the frequency inverter can cause electromagnetic interference in the input and output that can be propagated by cable (via the power input lines), by wireless radiation to nearby equipment (e.g. AM radios) or via data and signal lines. Install an optional filter if present to reduce air propagated interference on the input side of the inverter. Use AC or DC reactors to reduce line propagated noise (harmonics). Use shielded motor power lines to reduce output noise.  
For EMC correct installation refer to the Manual for Frequency Inverters and EMC.
- Do not install a power factor correction capacitor, varistor or arrester on the inverter output side. This will cause the inverter to trip or the capacitor, varistor, or arrester to be damaged. If any of the above devices is installed, immediately remove it.
- Before starting wiring or other work after the inverter is operated, wait for at least 10 minutes after the power supply has been switched off, and check that there are no residual voltage using a tester or the like. The capacitor is charged with high voltage for some time after power off and it is dangerous.
- A short circuit or earth fault on the inverter output side may damage the inverter modules.
  - Fully check the insulation resistance of the circuit prior to inverter operation since repeated short circuits caused by peripheral circuit inadequacy or an earth fault caused by wiring inadequacy or reduced motor insulation resistance may damage the inverter modules.
  - Fully check the to-earth insulation and inter-phase insulation of the inverter output side before power-on.  
Especially for an old motor or use in hostile atmosphere, securely check the motor insulation resistance etc.
- Do not use the inverter input side magnetic contactor to start/stop the inverter.  
Since repeated inrush currents at power ON will shorten the life of the converter circuit (switching life is about 1,000,000 times), frequent starts and stops of the MC must be avoided.  
Always use the start signal (ON/OFF of STF and STR signals) to start/stop the inverter.
- Across P/+ and PR terminals, connect only an external regenerative brake discharge resistor. Do not connect a mechanical brake. The brake resistor can not be connected to the FR-D720S-008SC and 014SC. Leave terminals P/+ and PR open.  
Also, never short between P/+ and PR.



- Do not apply a voltage higher than the permissible voltage to the inverter I/O signal circuits.  
Application of a voltage higher than the permissible voltage to the inverter I/O signal circuits or opposite polarity may damage the I/O devices. Especially check the wiring to prevent the speed setting potentiometer from being connected incorrectly to short terminals 10-5.

- Provide electrical and mechanical interlocks for MC1 and MC2 which are used for bypass operation.

When the wiring is incorrect or if there is a bypass circuit as shown on the right, the inverter will be damaged by leakage current from the power supply due to arcs generated at the time of switch-over or chattering caused by a sequence error.

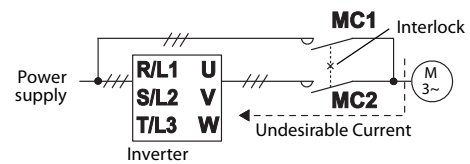

- If the machine must not be restarted when power is restored after a power failure, provide a magnetic contactor in the inverter's input side and also make up a sequence which will not switch ON the start signal.

If the start signal (start switch) remains ON after a power failure, the inverter will automatically restart as soon as the power is restored.

- Inverter input side magnetic contactor (MC)

On the inverter input side, connect a MC for the following purposes. (Refer to the Instruction Manual.)

- To release the inverter from the power supply when a fault occurs or when the drive is not functioning (e. g. emergency stop operation). For example, MC avoids overheat or burnout of the brake resistor when heat capacity of the resistor is insufficient or brake regenerative transistor is damaged with short while connecting an optional brake resistor.
- To prevent any accident due to an automatic restart at restoration of power after an inverter stop made by a power failure
- To separate the inverter from the power supply to ensure safe maintenance and inspection work. If using an MC for emergency stop during operation, select an MC regarding the inverter input side current as JEM1038-AC-3 class rated current.

- Handling of inverter output side magnetic contactor

Switch the magnetic contactor between the inverter and motor only when both the inverter and motor are at a stop. When the magnetic contactor is turned ON while the inverter is operating, overcurrent protection of the inverter and such will activate. When MC is provided for switching to the commercial power supply, for example, switch it ON/OFF after the inverter and motor have stopped.

- Instructions for overload operation

When performing operation of frequent start/stop of the inverter, increase/decrease in the temperature of the transistor element of the inverter may repeat due to a continuous flow of large current, shortening the life from thermal fatigue. Since thermal fatigue is related to the amount of current, the life can be increased by reducing bound current, starting current, etc. Decreasing current may increase the life. However, decreasing current will result in insufficient torque and the inverter may not start. Therefore, increase the inverter capacity to have enough allowance for current.

- Make sure that the specifications and rating match the system requirements.

- When the motor speed is unstable, due to change in the frequency setting signal caused by electromagnetic noises from the inverter, take the following measures when applying the motor speed by the analog signal.

- Do not run the signal cables and power cables (inverter I/O cables) in parallel with each other and do not bundle them.
- Run signal cables as far away as possible from power cables (inverter I/O cables).
- Use shielded cables as signal cables.
- Install a ferrite core on the signal cable (Example: ZCAT3035-1330 TDK).

## 6 FAILSAFE OF THE SYSTEM WHICH USES THE INVERTER

When a fault occurs, the inverter trips to output a fault signal. However, a fault output signal may not be output at an inverter fault occurrence when the detection circuit or output circuit fails, etc. Although Mitsubishi Electric assures best quality products, provide an interlock which uses inverter status output signals to prevent accidents such as damage to machine when the inverter fails for some reason.

At the same time consider the system configuration where failsafe from outside the inverter, without using the inverter, is enabled even if the inverter fails.

### Interlock Method which uses the Inverter Status Output Signals

By combining the inverter status output signals to provide an interlock as shown below, an inverter alarm can be detected.

Interlock Method	Check Method	Used Signals	Refer to
Inverter protective function operation	Operation check of an alarm contact Circuit error detection by negative logic	Fault output signal (ALM signal)	Refer to chapter "Parameter" of the Instruction Manual
Inverter running status	Operation ready signal check	Operation ready signal (RY signal)	
	Logic check of the start signal and running signal	Start signal (STF signal, STR signal) Running signal (RUN signal)	
	Logic check of the start signal and output current	Start signal (STF signal, STR signal) Output current detection signal (Y12 signal)	

### Backup Method Outside the Inverter

Even if the interlock is provided by the inverter status signal, enough failsafe is not ensured depending on the failure status of the inverter itself. For example, even if the interlock is provided using the inverter fault output signal, start signal and RUN signal output, there is a case where a fault output signal is not output and RUN signal is kept output even if an inverter fault occurs.

Provide a speed detector to detect the motor speed and current detector to detect the motor current and consider the backup system such as checking up as below according to the level of importance of the system. Check the motor running and motor current while the start signal is input to the inverter by comparing the start signal to the inverter and detected speed of the speed detector or detected current of the current detector. Note that the motor current runs as the motor is running for the period until the motor stops since the inverter starts decelerating even if the start signal turns off. For the logic check, configure a sequence considering the inverter deceleration time. In addition, it is recommended to check the three-phase current when using the current detector.

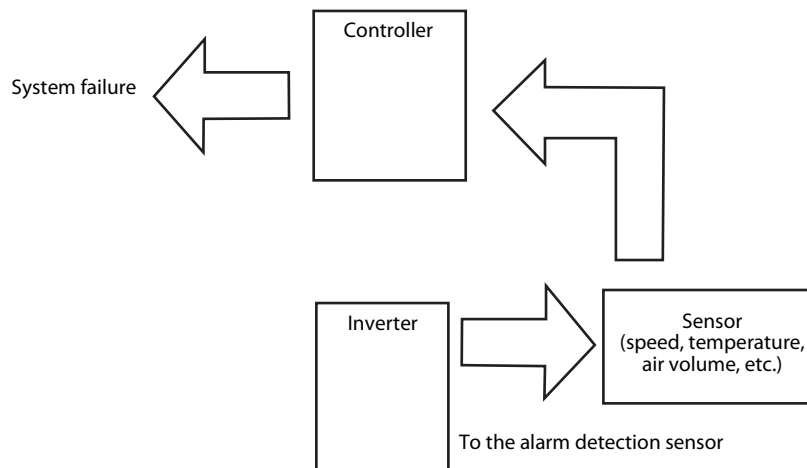

Check if there is no gap between the actual speed and commanded speed by comparing the inverter speed command and detected speed of the speed detector.

## 7 PARAMETER

For simple variable-speed operation of the inverter, the initial setting of the parameters may be used. Set the necessary parameters to meet the load and operational specifications. Parameter setting, change and check can be made from the operation panel. For details of parameters, refer to the instruction manual.

In the initial setting of Pr. 160 *Extended function display selection*, simple mode and extended mode parameters are displayed.

Parameter	Name	Initial Value	Setting Range	Remarks
160	Extended function display selection	0	0	Simple mode and extended mode parameters can be displayed.
			9999	Only the simple mode parameters can be displayed.

### NOTES

- The parameters marked © are the simple mode parameters.
- The parameters marked with  in the table allow its setting to be changed during operation even if "0" (initial value) is set in Pr. 77 *Parameter write selection*.

Parameter	Name	Setting Range	Initial Value	Parameter	Name	Setting Range	Initial Value
© 0	Torque boost	0 to 30 %	6/4/3 % *1	17	MRS input selection	0, 2, 4	0
© 1	Maximum frequency	0 to 120 Hz	120 Hz	18	High speed maximum frequency	120 to 400 Hz	120 Hz
© 2	Minimum frequency	0 to 120 Hz	0 Hz	19	Base frequency voltage	0 to 1000 V, 8888, 9999	8888
© 3	Base frequency	0 to 400 Hz	50 Hz	20	Acceleration/ deceleration reference frequency	1 to 400 Hz	50 Hz
© 4	Multi-speed setting (high speed)	0 to 400 Hz	50 Hz	22	Stall prevention operation level	0 to 200 %	150 %
© 5	Multi-speed setting (middle speed)	0 to 400 Hz	30 Hz	23	Stall prevention operation level compensation factor at double speed	0 to 200 %, 9999	9999
© 6	Multi-speed setting (low speed)	0 to 400 Hz	10 Hz	24 to 27	Multi-speed setting 4 speed to 7 speed	0 to 400 Hz, 9999	9999
© 7	Acceleration time	0 to 3600 s	5 s/10 s *2	29	Acceleration/ deceleration pattern selection	0, 1, 2	0
© 8	Deceleration time	0 to 3600 s	5 s/10 s *2	30	Regenerative function selection	0, 1, 2	0
© 9	Electronic thermal O/L relay	0 to 500 A	Rated inverter current	31	Frequency jump 1A	0 to 400 Hz, 9999	9999
10	DC injection brake operation frequency	0 to 120 Hz	3 Hz	32	Frequency jump 1B		9999
11	DC injection brake operation time	0 to 10 s	0.5 s	33	Frequency jump 2A		9999
12	DC injection brake operation voltage	0 to 30 %	6/4 % *3	34	Frequency jump 2B		9999
13	Starting frequency	0 to 60 Hz	0.5 Hz	35	Frequency jump 3A		9999
14	Load pattern selection	0 to 3	0	36	Frequency jump 3B		9999
15	Jog frequency	0 to 400 Hz	5 Hz				
16	Jog acceleration/ deceleration time	0 to 3600 s	0.5 s				

\*1 Differs according to capacities.  
 6 %: FR-D720S-042SC or less, FR-D740-022SC or less  
 4 %: FR-D720S-070SC and 100SC, FR-D740-036SC to 080SC  
 3 %: FR-D740-120SC and 160SC

\*2 Differs according to capacities.  
 5 s: FR-D720S-008SC to 100SC, FR-D740-080SC or less  
 10 s: FR-D740-120SC and 160SC

\*3 Differs according to capacities.  
 6 %: FR-D720S-008SC and 014SC  
 4 %: FR-D720S-025SC and 100SC, FR-D740-012SC to 160SC

Parameter	Name	Setting Range	Initial Value
37	Speed display	0, 0.01 to 9998	0
40	RUN key rotation direction selection	0, 1	0
41	Up-to-frequency sensitivity	0 to 100 %	10 %
42	Output frequency detection	0 to 400 Hz	6 Hz
43	Output frequency detection for reverse rotation	0 to 400 Hz, 9999	9999
44	Second acceleration/ deceleration time	0 to 3600 s	5 s/10 *1
45	Second deceleration time	0 to 3600, 9999	9999
46	Second torque boost	0 to 30 %, 9999	9999
47	Second V/F (base frequency)	0 to 400 Hz, 9999	9999
48	Second stall prevention operation current	0 to 200 %, 9999	9999
51	Second electronic thermal O/L relay	0 to 500 A, 9999	9999
52	DU/PU main display data selection	0, 5, 8 to 12, 14, 20, 23 to 25, 52 to 55, 61, 62, 64, 100	0
55	Frequency monitoring reference	0 to 400 Hz	50 Hz
56	Current monitoring reference	0 to 500 A	Rated inverter current
57	Restart coasting time	0, 0.1 to 5 s, 9999	9999
58	Restart cushion time	0 to 60 s	1 s
59	Remote function selection	0, 1, 2, 3	0
60	Energy saving control selection	0, 9	0
65	Retry selection	0 to 5	0
66	Stall prevention operation reduction starting frequency	0 to 400 Hz	50 Hz
67	Number of retries at alarm occurrence	0 to 10, 101 to 110	0
68	Retry waiting time	0.1 to 600s	1s
69	Retry count display erase	0	0

Parameter	Name	Setting Range	Initial Value
70	Special regenerative brake duty	0 to 30 %	0 %
71	Applied motor	0, 1, 3, 13, 23, 40, 43, 50, 53	0
72	PWM frequency selection	0 to 15	1
73	Analog input selection	0, 1, 10, 11	1
74	Input filter time constant	0 to 8	1
75	Reset selection/ disconnected PU detection/PU stop selection	0 to 3, 14 to 17	14
77	Parameter write selection	0, 1, 2	0
78	Reverse rotation prevention selection	0, 1, 2	0
© 79	Operation mode selection	0, 1, 2, 3, 4, 6, 7	0
80	Motor capacity	0.1 to 7.5 kW, 9999	9999
82	Motor excitation current	0 to 500 A, 9999	9999
83	Motor rated voltage	0 to 1000 V	200 V/ 400 V *2
84	Rated motor frequency	10 to 120 Hz	50 Hz
90	Motor constant (R1)	0 to 50 Ω, 9999	9999
96	Auto tuning setting status	0, 11, 21	0
117	PU communication station number	0 to 31 (0 to 247)	0
118	PU communication speed	48, 96, 192, 384	192
119	PU communication stop bit length	0, 1, 10, 11	1
120	PU communication parity check	0, 1, 2	2
121	Number of PU communication retries	0 to 10, 9999	1
122	PU communication check time interval	0, 0.1 to 999.8 s, 9999	0
123	PU communication waiting time setting	0 to 150 ms, 9999	9999
124	PU communication CR/LF presence/absence selection	0, 1, 2	1
© 125	Terminal 2 frequency setting gain frequency	0 to 400 Hz	50 Hz
© 126	Terminal 4 frequency setting gain frequency	0 to 400 Hz	50 Hz
127	PID control automatic switchover frequency	0 to 400 Hz, 9999	9999

\*1 Differs according to capacities.  
5 s: FR-D720S-008SC to 100SC, FR-D740-080SC or less  
10 s: FR-D740-120SC and 160SC

\*2 The initial value differs according to the voltage class:  
200 V/400 V



Parameter	Name	Setting Range	Initial Value
128	PID action selection	0, 20, 21, 40 to 43	0
129	PID proportional band	0.1 to 1000 %, 9999	100 %
130	PID integral time	0.1 to 3600 s, 9999	1 s
131	PID upper limit	0 to 100 %, 9999	9999
132	PID lower limit	0 to 100 %, 9999	9999
133	PID action set point	0 to 100 %, 9999	9999
134	PID differential time	0.01 to 10 s, 9999	9999
145	PU display language selection	0 to 7	1
146	Parameter for manufacturer setting. Do not set.		
150	Output current detection level	0 to 200 %	150 %
151	Output current detection signal delay time	0 to 10 s	0 s
152	Zero current detection level	0 to 200 %	5 %
153	Zero current detection time	0 to 1 s	0.5 s
156	Stall prevention operation selection	0 to 31, 100, 101	0
157	OL signal output timer	0 to 25 s, 9999	0 s
158	AM terminal function selection	1 to 3, 5, 8 to 12, 14, 21, 24, 52, 53, 61, 62	1
©160	Extended function display selection	0, 9999	0
161	Frequency setting/ key lock operation selection	0, 1, 10, 11	0
162	Automatic restart after instantaneous power failure selection	0, 1, 10, 11	1
165	Stall prevention operation level for restart	0 to 200 %	150 %
166	Output current detection signal retention time	0 to 10 s, 9999	0.1 s
167	Output current detection operation selection	0, 1	0
168	Parameter for manufacturer setting.		
169	Do not set.		
170	Watt-hour meter clear	0, 10, 9999	9999
171	Operation hour meter clear	0, 9999	9999
178	STF terminal function selection	0 to 5, 7, 8, 10, 12, 14, 16, 18, 24, 25, 37, 60, 62, 65 to 67, 9999	60

Parameter	Name	Setting Range	Initial Value
179	STR terminal function selection	0 to 5, 7, 8, 10, 12, 14, 16, 18, 24, 25, 37, 61, 62, 65 to 67, 9999	61
180	RL terminal function selection	0 to 5, 7, 8, 10, 12, 14, 16, 18, 24, 25, 37, 62, 65 to 67, 9999	0
181	RM terminal function selection		1
182	RH terminal function selection		2
190	RUN terminal function selection	0, 1, 3, 4, 7, 8, 11 to 16, 25, 26, 46, 47, 64, 70, 80, 81, 90, 91, 93, 95, 96, 98, 99, 100, 101, 103, 104, 107, 108, 111 to 116, 125, 126, 146, 147, 164, 170, 180, 181, 190, 191, 193, 195, 196, 198, 199, 9999	0
192	ABC terminal function selection	0, 1, 3, 4, 7, 8, 11 to 16, 25, 26, 46, 47, 64, 70, 80, 81, 90, 91, 95, 96, 98, 99, 100, 101, 103, 104, 107, 108, 111 to 116, 125, 126, 146, 147, 164, 170, 180, 181, 190, 191, 195, 196, 198, 199, 9999	99
197	SO terminal function selection	0, 1, 3, 4, 7, 8, 11 to 16, 25, 26, 46, 47, 64, 70, 80, 81, 90, 91, 93, 95, 96, 98, 99, 100, 101, 103, 104, 107, 108, 111 to 116, 125, 126, 146, 147, 164, 170, 180, 181, 190, 191, 193, 195, 196, 198, 199	80
232 to 239	Multi-speed setting (speeds 8 to 15)	0 to 400 Hz, 9999	9999
240	Soft-PWM operation selection	0, 1	1
241	Analog input display unit switchover	0, 1	0
244	Cooling fan operation selection	0, 1	1
245	Rated slip	0 to 50 %, 9999	9999
246	Slip compensation time constant	0.01 to 10 s	0.5 s
247	Constant-power range slip compensation selection	0, 9999	9999
249	Earth (ground) fault detection at start	0, 1	0
250	Stop selection	0 to 100 s, 1000 to 1100 s, 8888, 9999	9999
251	Output phase loss protection selection	0, 1	1
255	Life alarm status display	(0 to 15)	0
256	Inrush current suppression circuit life display	(0 to 100 %)	100 %



Parameter	Name	Setting Range	Initial Value
257	Control circuit capacitor life display	(0 to 100 %)	100 %
258	Main circuit capacitor life display	(0 to 100 %)	100 %
259	Main circuit capacitor life measuring	0, 1 (2, 3, 8, 9)	0
260	PWM frequency automatic switchover	0, 1	0
261	Power failure stop selection	0, 1, 2	0
267	Terminal 4 input selection	0, 1, 2	0
268	Monitor decimal digits selection	0, 1, 9999	9999
269	Parameter for manufacturer setting. Do not set.		
295	Magnitude of frequency change setting	0, 0.01, 0.10, 1.00, 10.00	0
296	Password lock level	1 to 6, 101 to 106, 9999	9999
297	Password lock/unlock	1000 to 9998 (0 to 5, 9999)	9999
298	Frequency search gain	0 to 32767, 9999	9999
299	Rotation direction detection selection at restarting	0, 1, 9999	0
338	Communication operation command source	0, 1	0
339	Communication speed command source	0, 1, 2	0
340	Communication startup mode selection	0, 1, 10	0
342	Communication EEPROM write selection	0, 1	0
343	Communication error count	—	0
450	Second applied motor	0, 1, 9999	9999
495	Remote output selection	0, 1, 10, 11	0
496	Remote output data 1	0 to 4095	0
502	Stop mode selection at communication error	0, 1, 2	0
503	Maintenance timer	0 (1 to 9998)	0
504	Maintenance timer alarm output set time	0 to 9998, 9999	9999
549	Protocol selection	0, 1	0
551	PU mode operation command source selection	2, 4, 9999	9999

Parameter	Name	Setting Range	Initial Value
555	Current average time	0.1 to 1 s	1 s
556	Data output mask time	0 to 20 s	0 s
557	Current average value monitor signal output reference current	0 to 500 A	Rated inverter current
561	PTC thermistor protection level	0.5 to 30 k $\Omega$ , 9999	9999
563	Energization time carrying-over times	(0 to 65535)	0
564	Operating time carrying-over times	(0 to 65535)	0
571	Holding time at a start	0.0 to 10.0 s, 9999	9999
575	Output interruption detection time	0 to 3600 s, 9999	1 s
576	Output interruption detection level	0 to 400 Hz	0 Hz
577	Output interruption cancel level	900 to 1100 %	1000 %
592	Traverse function selection	0, 1, 2	0
593	Maximum amplitude amount	0 to 25 %	10 %
594	Amplitude compensation amount during deceleration	0 to 50 %	10 %
595	Amplitude compensation amount during acceleration	0 to 50 %	10 %
596	Amplitude acceleration time	0.1 to 3600 s	5 s
597	Amplitude deceleration time	0.1 to 3600 s	5 s
611	Acceleration time at a restart	0 to 3600 s, 9999	9999
653	Speed smoothing control	0 to 200 %	0
665	Regeneration avoidance frequency gain	0 to 200 %	100
872 *1	Input phase loss protection selection	0, 1	1
882	Regeneration avoidance operation selection	0, 1, 2	0
883	Regeneration avoidance operation level	300 to 800 V	400 V/ 780 V DC *2
885	Regeneration avoidance compensation frequency limit value	0 to 10 Hz, 9999	6 Hz
886	Regeneration avoidance voltage gain	0 to 200 %	100 %
888	Free parameter 1	0 to 9999	9999

\*1 Available only for the three-phase power input specification model.

\*2 The initial value differs according to the voltage class:  
200 V/400 V



Parameter	Name	Setting Range	Initial Value
<b>889</b>	<b>Free parameter 2</b>	0 to 9999	9999
<b>891</b>	<b>Cumulative power monitor digit shifted times</b>	0 to 4, 9999	9999
<b>C1 (901) *1</b>	<b>AM terminal calibration</b>	—	—
<b>C2 (902) *1</b>	<b>Terminal 2 frequency setting bias frequency</b>	0 to 400 Hz	0 Hz
<b>C3 (902) *1</b>	<b>Terminal 2 frequency setting bias</b>	0 to 300 %	0 %
<b>125 (903) *1</b>	<b>Terminal 2 frequency setting gain frequency</b>	0 to 400 Hz	50 Hz
<b>C4 (903) *1</b>	<b>Terminal 2 frequency setting gain</b>	0 to 300 %	100 %
<b>C5 (904) *1</b>	<b>Terminal 4 frequency setting bias frequency</b>	0 to 400 Hz	0 Hz
<b>C6 (904) *1</b>	<b>Terminal 4 frequency setting bias</b>	0 to 300 %	20 %

Parameter	Name	Setting Range	Initial Value
<b>126 (905) *1</b>	<b>Terminal 4 frequency setting gain frequency</b>	0 to 400 Hz	50 Hz
<b>C7 (905) *1</b>	<b>Terminal 4 frequency setting gain</b>	0 to 300 %	100 %
<b>C22 (922) *1</b>	<b>Parameter for manufacturer setting. Do not set.</b>		
<b>C23 (922) *1</b>			
<b>C24 (923) *1</b>			
<b>C25 (923) *1</b>			
<b>990</b>		<b>PU buzzer control</b>	0, 1
<b>991</b>	<b>PU contrast adjustment</b>	0 to 63	58
<b>Pr.CL</b>	<b>Parameter clear</b>	0, 1	0
<b>ALLC</b>	<b>All parameter clear</b>	0, 1	0
<b>Er.CL</b>	<b>Alarm history clear</b>	0, 1	0
<b>Pr.CH</b>	<b>Initial value change list</b>	—	—

\*1 The parameter number in parentheses is the one for use with the operation panel (FR-PA02-02) for the FR-E500 series or parameter unit (FR-PU04/FR-PU07).

---

---

## 8 TROUBLESHOOTING

---

---

The frequency inverter FR-D700 SC has a multitude of protective functions which protect the drive and the inverter from damage in case of a fault. When a fault occurs in the inverter, the protective function is activated bringing the inverter to an alarm stop and the PU display automatically changes to any of the following fault (alarm) indications.

If the fault does not correspond to any of the following faults or if you have any other problem, please contact your sales representative.

- Retention of fault output signal.....When the magnetic contactor (MC) provided on the input side of the inverter is opened at the activation of the protective function, the inverter's control power will be lost and the alarm output will not be held.
- Fault or alarm display.....When a fault or alarm occurs, the operation panel display automatically switches to the fault or alarm indication.
- Resetting method .....When a protective function of the inverter is activated, the power output of the inverter is blocked (motor is coasting). The inverter cannot start up again unless an automatic restart has been configured or the inverter is reset. Please observe carefully the warnings contained below in the configuration of an automatic restart or the execution of a reset.
- If protective functions were activated (i. e. the inverter switched off with an error message) follow the instructions for error correction provided in the manual for the inverter. Especially in the case of short circuits or earth contacts in the inverter output and mains overvoltages the cause of the fault must be determined prior to switching on again as a recurrence of such faults at short intervals can lead to premature aging of components or even the complete breakdown of the device. After the cause of the fault has been found and corrected the inverter can be reset and operations continue.

Inverter fault or alarm indications are roughly divided as below.

- Error Message  
A message regarding operational fault and setting fault by the operation panel and parameter unit (FR-PU04/FR-PU07) is displayed. The inverter does not shut off output.
- Warning  
The inverter does not shut off output even when a warning is displayed. However, failure to take appropriate measures will lead to a major fault.
- Alarm  
The inverter does not shut off output. You can also output an alarm signal by making parameter setting.
- Fault  
When the protective function is activated, the inverter output is shut off and an fault signal is output.

### NOTES

- For the details of fault displays and other malfunctions, also refer to the Instruction Manual.
- Past eight faults can be displayed using the setting dial.



## 8.1 Reset Method of Protective Function

### Resetting the Inverter

The inverter can be reset by performing any of the following operations. Note that the internal thermal integrated value of the electronic thermal relay function and the number of retries are cleared (erased) by resetting the inverter. Inverter recovers about 1s after reset is cancelled.

Three different methods can be used to reset an inverter.

- Using the operation panel, press the STOP/RESET key to reset the inverter. (This may only be performed when a fault occurs.)

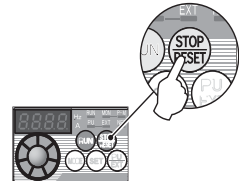

- Switch OFF the power once, then switch it ON again after the indicator of the operation panel turns OFF.

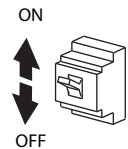

- Turn ON the reset signal (RES) for more than 0.1 s. (If the RES signal is kept ON, "Err." appears (flickers) to indicate that the inverter is in a reset status.)

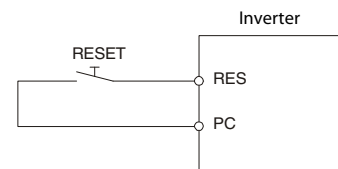

### **⚠ CAUTION**

OFF status of the start signal must be confirmed before resetting the inverter fault. Resetting inverter fault with the start signal ON restarts the motor suddenly. This may cause injury.

## 8.2 List of Alarm Display

Operation Panel Indication		Meaning	
Error messages	E---	E---	Faults history
	HOLD	HOLD	Operation panel lock
	Er1 to Er4	Er1 to 4	Parameter write error
	LOCd	LOCd	Password locked
	Err.	Err.	Inverter reset
Warnings	OL	OL	Stall Prevention (overcurrent)
	oL	oL	Stall prevention (overvoltage)
	rb	RB	Regenerative brake prealarm
	TH	TH	Electronic thermal relay function prealarm
	PS	PS	PU Stop
	MT	MT	Maintenance signal output
	UV	UV	Undervoltage
	SA	SA	Safety stop
Alarm	F <sub>n</sub>	FN	Fan alarm
Fault	E.O.C1	E.O.C1	Overcurrent shut-off during acceleration
	E.O.C2	E.O.C2	Overcurrent shut-off during constant speed
	E.O.C3	E.O.C3	Overcurrent shut-off during deceleration or stop
	E.O.V1	E.O.V1	Regenerative overvoltage shut-off during acceleration
	E.O.V2	E.O.V2	Regenerative overvoltage shut-off during constant speed
	E.O.V3	E.O.V3	Regenerative overvoltage shut-off during deceleration or stop
	E.THT	E.THT	Inverter overload shut-off (electronic thermal relay function)
	E.THM	E.THM	Motor overload shut-off (electronic thermal relay function)
E.FIn	E.FIN	Fin overheat	

Operation Panel Indication		Meaning	
Fault	E.I.LF	E.I.LF*	Input phase loss
	E.O.LT	E.OLT	Stall prevention
	E.bE	E.BE	Brake transistor alarm detection
	E.GF	E.GF	Output side earth (ground) fault overcurrent protection
	E.LF	E.LF	Output phase loss
	E.OHT	E.OHT	External thermal relay operation
	E.PTC	E.PTC*	PTC thermistor operation
	E.PE	E.PE	Parameter storage device fault
	E.PUE	E.PUE	PU disconnection
	E.RET	E.RET	Retry count excess
	E.S1 E.CPU	E.5/E.CPU	CPU fault
	E.CDO	E.CDO*	Output current detection value exceeded
	E.IOH	E.IOH*	Inrush current limit circuit fault
	E.AIE	E.AIE*	Analog input fault
E.SAF	E.SAF*	Safety circuit fault	

\* If an E.I.LF, E.PTC, E.CDO, E.IOH, E.AIE, or E.SAF fault occurs when using the FR-PU04, "Fault 14" is displayed on the FR-PU04.

---

---

## 9 MAINTENANCE AND INSPECTION

---

---

### 9.1 Daily Inspection

---

Followings are the daily checking points during operation:

- Rotation speed of motor
- Environmental condition of the inverter drive
- Activation of cooling system
- Extraordinary vibration or airborne noise
- Over heating or discoloration

For detailed checking operation please refer to the Instruction manual of FR-D700 SC.

### 9.2 Periodic Inspection

---

It is recommended to make the following checks periodically:

- Check for loose screws in the terminal block. Retighten any loose screws.
- Check for dust accumulation on the inverter. Clean the heat sink and the cooling fan of the inverter.
- Check for unusual noise generated from the inverter. Retighten installation screw.
- Check for the operation condition. Keep the operation condition of inverter as written in the Inverter FR-D700 SC Instruction Manual.
- For detailed maintenance operation please refer to the Instruction manual of FR-D700 SC.

<b>⚠ CAUTION</b>
------------------

- |  |
|--|
| <ul style="list-style-type: none"><li>• To avoid an electric shock hazard, insert the magnetic contactor (MC) between AC power supply and FR-D700 SC. Open the contact of MC and keep away from drive for discharging time (10 minutes) before performing any work on the drive. And verify that the voltage on the bus capacitors has discharged before Measure the DC bus voltage at the P/+ and N/- terminals or test points (refer to <i>page 6</i> "Main circuit terminal specifications" for locations). The voltage must be zero.</li><li>• Do not carry out a megger (insulation resistance) test on the control circuit of the inverter. It will cause a failure.</li></ul> |
|--|

### 9.3 Checking and Testing of Restart Prevention

---

To avoid systematic faults, a test even for faulty demands of the safety function has to be performed in order to check the correct function of the restart prevention.

This test shall be carried out at system installation, any software changes, parameterization changes, and/or at least once per year. For detailed checking procedure refer to the "Transistorized Inverter FR-D700 SC Safety stop function Instruction Manual".

<b>⚠ CAUTION</b>
------------------

<p>Any misuse of safety function could lead to personal injury or death, property damage, or economic loss. To ensure that the system complies fully with requirement of safety, make a system-level risk assessment and adequate verification for systematic failure.</p>
--

# 10 SPECIFICATIONS

## Category of Safe Torque Off Function

The FR-D700 SC adjustable frequency AC drive family is suitable for emergency stop according to EN 60204-1, stop category 0 within safety related applications according to EN954-1 up to safety category 3.

### 200 V Class

Model FR-D720S-□□□SC-EC		008	014	025	042	070	100
Rated motor capacity [kW] *1		0.1	0.2	0.4	0.75	1.5	2.2
Output	Output capacity [kVA] *2	0.3	0.6	1.0	1.7	2.8	4.0
	Rated current [A]	0.8	1.4	2.5	4.2	7.0	10.0
	Overload current rating *3	200% of rated motor capacity for 0.5s; 150 % for 60 s					
	Voltage *4	3-phase AC, 0 V to power supply voltage					
	Regenerative braking torque *5	150 %		100 %		50 %	20 %
Power supply	Power supply voltage	1-phase, 200–240 V AC					
	Voltage range	170–264 V AC at 50/60 Hz					
	Power supply frequency	50/60 Hz ± 5 %					
	Rated input capacity [kVA] *6	0.5	0.9	1.5	2.3	4.0	5.2
Protective structure		IP20					
Cooling system		Self cooling				Forced air cooling	
Weight [kg]		0.5	0.5	0.9	1.1	1.5	2.0

### 400 V Class

Model FR-D740-□□□SC-EC		012	022	036	050	080	120	160
Rated motor capacity [kW] *1		0.4	0.75	1.5	2.2	3.7	5.5	7.5
Output	Output capacity [kVA] *2	0.9	1.7	2.7	3.8	6.1	9.1	12.2
	Rated current [A] *7	1.2 (1.4)	2.2 (2.6)	3.6 (4.3)	5.0 (6.0)	8.0 (9.6)	12.0 (14.4)	16.0 (19.2)
	Overload current rating *3	200% of rated motor capacity for 0.5 s; 150% for 60 s						
	Voltage *4	3-phase AC, 0 V to power supply voltage						
	Regenerative braking torque *5	100 %		50 %		20 %		
Power supply	Power supply voltage	3-phase, 380–480 V AC						
	Voltage range	325–528 V AC at 50/60 Hz						
	Power supply frequency	50/60 Hz ± 5 %						
	Rated input capacity [kVA] *6	1.5	2.5	4.5	5.5	9.5	12	17
Protective structure		IP20						
Cooling system		Self cooling			Forced air cooling			
Weight [kg]		1.3	1.3	1.4	1.5	1.5	3.3	3.3

\*1 The applied motor capacity indicated is the maximum capacity applicable for use of the Mitsubishi Electric 4-pole standard motor.

\*2 The rated output capacity indicated assumes that the output voltage is 230 V/440 V (200 V class/400 V class).

\*3 The % value of the overload current rating indicated is the ratio of the overload current to the inverter's rated output current (ambient temperature of 50 °C for 400 V class). For repeated duty, allow time for the inverter and motor to return to or below the temperatures under 100 % load.

\*4 The maximum output voltage does not exceed the power supply voltage. The maximum output voltage can be changed within the setting range. However, the pulse voltage value of the inverter output side voltage remains unchanged at about  $\sqrt{2}$  that of the power supply.

\*5 The braking torque indicated is a short-duration average torque (which varies with motor loss) when the motor alone is decelerated from 60 Hz in the shortest time and is not a continuous regenerative torque. When the motor is decelerated from the frequency higher than the base frequency, the average deceleration torque will reduce. Since the inverter does not contain a brake resistor, use the optional brake resistor when regenerative energy is large. A brake unit (FR-BU2) may also be used.

\*6 The power supply capacity varies with the value of the power supply side inverter impedance (including those of the input reactor and cables).

\*7 When operating the inverter with ambient temperature of 40 °C maximum, the rated output current is the value in parentheses.

---

---

# A APPENDIX

---

---

## A.1 Instructions for Compliance with the EU Directives

---

The EU Directives are issued to standardize different national regulations of the EU Member States and to facilitate free movement of the equipment, whose safety is ensured, in the EU territory.

Since 1996, compliance with the EMC Directive that is one of the EU Directives has been legally required. Since 1997, compliance with the Low Voltage Directive, another EU Directive, has been also legally required. When a manufacturer confirms its equipment to be compliant with the EMC Directive and the Low Voltage Directive, the manufacturer must declare the conformity and affix the CE marking.

- The authorized representative in the EU  
Name: Mitsubishi Electric Europe B.V.  
Address: Gothaer Strasse 8, 40880 Ratingen, Germany

### NOTE

We declare that this inverter, when equipped with the dedicated EMC filter, conforms with the EMC Directive in industrial environments and affix the CE marking on the inverter. When using the inverter in a residential area, take appropriate measures and ensure the conformity of the inverter used in the residential area.

### A.1.1 EMC Directive

We declare that this inverter, when equipped with the EMC Directive compliant EMC filter, conforms with the EMC Directive and affix the CE marking on the inverter.

- EMC Directive: 2004/108/EC
- Standard(s): EN61800-3:2004 (Second environment/PDS Category "C3")

### NOTES

- First environment  
Environment including residential buildings. Includes building directly connected without a transformer to the low voltage power supply network which supplies power to residential buildings.
- Second environment  
Environment including all buildings except buildings directly connected without a transformer to the lower voltage power supply network which supplies power to residential buildings.

### NOTES

- Set the EMC Directive compliant EMC filter to the inverter. Insert line noise filters and ferrite cores to the power and control cables as required.
- Connect the inverter to an earthed power supply.
- Install a motor, the EMC Directive compliant EMC filter, and a control cable according to the instructions written in the EMC Installation Guidelines (BCN-A21041-204). (Please contact your sales representative for the EMC Installation Guidelines.)
- The cable length between the inverter and the motor is 5 m maximum.
- Confirm that the final integrated system with the inverter conforms with the EMC Directive.



## A.1.2 Low Voltage Directive

We have self-confirmed our inverters as products compliant to the Low Voltage Directive (conforming standard EN 61800-5-1) and placed the CE mark on the inverters.

### Outline of Instructions

- If your application requires by installation standards an RCD (residual current device) as up stream protection please select according to DIN VDE 0100-530 as following:  
Single phase inverter type A or B  
Three phase inverter only type B.
  - Additionally, when selecting a residual current device (RCD), leakage current caused by the mains filter, the length of the shielded motor cable and the carrier frequency must be taken into consideration.
  - When connecting AC current using switches without a step function, brief asymmetrical loads may result in unwanted triggering of the residual current device (RCD). It is recommendable here to use a Type B residual current device (RCD) Type B with delayed actuation or to switch on all three phases simultaneously using a main contactor.
- If you do not use a residual current operated protective device, provide double or reinforced insulation between the inverter and other equipment, or put a transformer between the main power supply and inverter.
- Do not use a residual current operated protective device (RCD) as an electric shock protector without connecting the equipment to the earth. Connect the equipment to the earth securely.
- Wire the earth terminal independently. (Do not connect two or more cables to one terminal.)
- Use the cable sizes on *page 7* under the following conditions.
  - Ambient temperature: 40 °C maximum
  - If conditions are different from above, select appropriate wire according to EN 60204 ANNEX C TABLE 5.
- Use a tinned (plating should not include zinc) crimping terminal to connect the earth cable. When tightening the screw, be careful not to damage the threads.
- For use as a product compliant with the Low Voltage Directive, use PVC cable whose size is indicated on *page 8*.
- Use the moulded case circuit breaker and magnetic contactor which conform to the EN or IEC Standard.
- Use the inverter under the conditions of overvoltage category II (usable regardless of the earth (ground) condition of the power supply), overvoltage category III (usable with the earthed-neutral system power supply, 400 V class only) specified in IEC664.
- To use the inverter under the conditions of pollution degree 3, install it in the enclosure of IP54 or higher.
- To use the inverter (IP20) outside of an enclosure in the environment of pollution degree 2, fix a fan cover with the fan cover fixing screws enclosed.

FR-D720S-070SC and 100SC, FR-D740-080SC or less

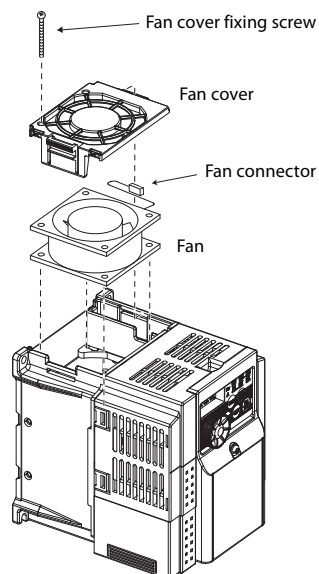

Example for FR-D740-036SC

FR-D740-120SC or more

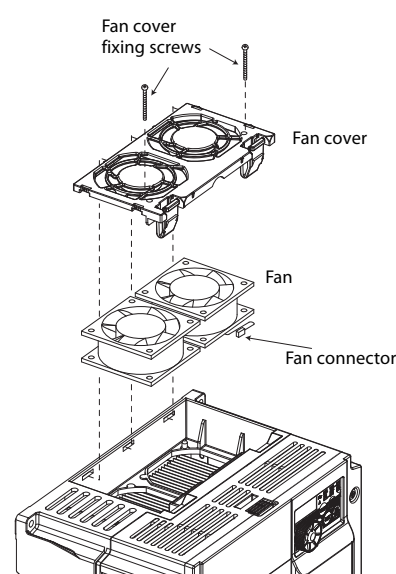

Example for FR-D740-160SC

- On the input and output of the inverter, use cables of the type and size set forth in EN 60204 Appendix C.
- The operating capacity of the relay outputs (terminal symbols A, B, C) should be 30 V DC, 0.3 A. (Relay outputs are basically isolated from the inverter internal circuit.)
- Control circuit terminals on *page 5* are safely isolated from the main circuit.



**Environment**

	During Operation	In Storage	During Transportation
Ambient temperature	-10 °C to +50 °C	-20 °C to +65 °C	-20 °C to +65 °C
Ambient humidity	90 % RH or less (non condensing)	90 % RH or less (non condensing)	90 % RH or less (non condensing)
Maximum altitude	1000 m	1000 m	10000 m

**Wiring protection**

Select a UL and cUL certified fuse with Class T fuse equivalent cut-off speed or faster with the appropriate rating for branch circuit protection, or a UL489 molded case circuit breaker (MCCB) in accordance with the tables below.

FR-D720S-□□□SC-EC (C)		008	014	025	042	070	100
Rated fuse voltage [V]		240 V or more					
Fuse maximum allowable rating [A] *	Without power factor improving reactor	15	20	20	30	40	60
	With power factor improving reactor	15	20	20	20	30	50
Molded case circuit breaker (MCCB) Maximum allowable rating [A] *		15	15	15	20	25	40

FR-D740-□□□SC-EC (C)		012	022	036	050	080	120	160
Rated fuse voltage [V]		480 V or more						
Fuse maximum allowable rating [A] *	Without power factor improving reactor	6	10	15	20	30	40	70
	With power factor improving reactor	6	10	10	15	25	35	60
Molded case circuit breaker (MCCB) Maximum allowable rating [A] *		15	15	15	15	20	30	40

\* Maximum allowable rating by US National Electrical Code. Exact size must be chosen for each installation.

**Motor Overload Protection**

The frequency inverters FR-D700 SC are equipped with a UL certified internal electronic thermal relay function.

When using the electronic thermal relay as motor overload protection, set the rated motor current to Pr. 9 *Electronic thermal O/L relay*.

**Electronic thermal relay function operation characteristic**

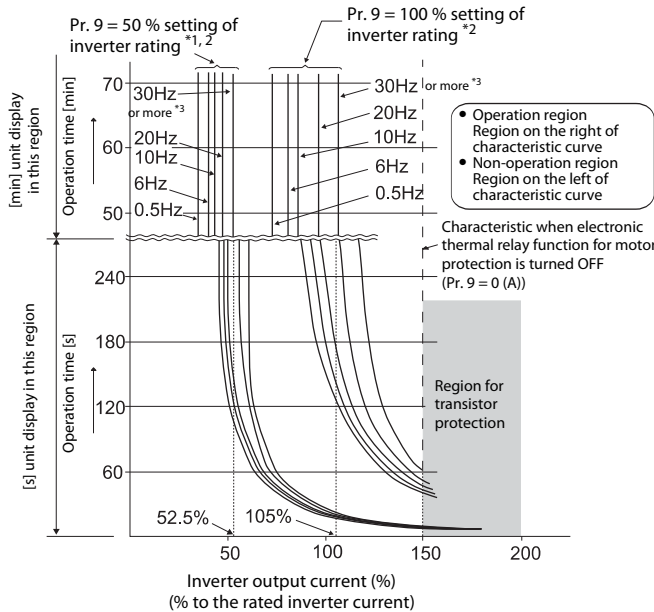

This function detects the overload (overheat) of the motor, stops the operation of the inverter's output transistor, and stops the output.

When using the Mitsubishi Electric constant-torque motor set "1" or any of "13", "50" or "53" in Pr. 71. This provides a 100 % continuous torque characteristic in the low-speed range. Set the rated current of the motor in Pr. 9.

\*1 When 50 % of the inverter rated output current (current value) is set in Pr. 9.

\*2 The % value denotes the percentage to the inverter rated output current. It is not the percentage to the motor rated current.

\*3 When you set the electronic thermal relay function dedicated to the Mitsubishi Electric constant-torque motor, this characteristic curve applies to operation at 6 Hz or higher.

---

---

**CAUTION**

---

---

- Protective function by electronic thermal relay function is reset by inverter power reset and reset signal input. Avoid unnecessary reset and power-OFF.
  - Install an external thermal relay (OCR) between the inverter and a motor when operating several motors by one inverter, or when using a multi-pole motor or special motor. In this case, set 0A to the electronic thermal O/L relay setting of the inverter. For the external thermal relay, determine the setting value in consideration of the current indicated on the motor's rating plate and the line-to-line leakage current. Self-cooling ability of a motor is reduced at low speed operation. Use a motor with a built-in thermal protector.
  - When the difference between the inverter and motor capacities is large and the setting is small, the protective characteristics of the electronic thermal relay function will be deteriorated. In this case, use an external thermal relay.
  - A special motor cannot be protected by the electronic thermal relay function. Use an external thermal relay.
- 
- 

**A.1.3 Short Circuit Ratings**

- 200 V class  
Suitable for use in a circuit capable of delivering not more than 5 kA rms symmetrical amperes, 264 V Maximum.
- 400 V class  
Suitable for use in a circuit capable of delivering not more than 5 kA rms symmetrical amperes, 528 V Maximum.



## A.2 Instructions for UL and cUL

(UL 508C, CSA C22.2 No.14)

### A.2.1 General Precaution

The bus capacitor discharge time is 10 minutes. Before starting wiring or inspection, switch power off, wait for more than 10 minutes, and check for residual voltage between terminal P/+ and N/- with a meter etc., to avoid a hazard of electrical shock.

### A.2.2 Environment

Before installation, check that the environment meets following specifications:

<b>Environment</b>	<b>Ambient temperature *</b>	-10 °C to +50 °C (non-freezing)	<div style="text-align: center;"> </div>
	<b>Ambient humidity</b>	90 % RH or less (non-condensing)	
	<b>Storage temperature</b>	-20 °C to +65 °C	
	<b>Atmosphere</b>	Indoors (free from corrosive gas, flammable gas, oil mist, dust and dirt)	
	<b>Altitude</b>	Maximum 1000 m above sea level	
	<b>Vibration</b>	5.9 m/s <sup>2</sup> or less at 10 to 55 Hz (directions of X, Y, Z axes)	

\* Temperature measured at a measurement position in an enclosure.

### A.2.3 Installation

According to the UL certification the frequency inverters FR-D700 SC have been approved as products for use in enclosure. Design an enclosure so that the inverter ambient temperature, humidity and atmosphere satisfy the specifications of the above table.

#### Wiring protection

For installation in the United States, branch circuit protection must be provided in accordance with the National Electrical Code and any applicable provincial codes.

For installation in Canada, branch circuit protection must be provided in accordance with the Canada Electrical Code and any applicable provincial codes.

As specified, UL Class T fuses or any faster acting fuse with the appropriate rating or Listed UL 489 Molded Case Circuit Breaker (MCCB) must be employed. (Refer to *page 28*)

### A.2.4 Short Circuit Ratings

- 200 V class  
Suitable for use in a circuit capable of delivering not more than 100 kA rms symmetrical amperes, 264 V Maximum.
- 400 V class  
Suitable for use in a circuit capable of delivering not more than 100 kA rms symmetrical amperes, 528 V Maximum.

### A.2.5 Wiring

For wiring the input (L1, N, R/L1, S/L2, T/L3) and output (U, V, W) terminals of the inverter, use the UL listed copper, stranded wires (rated at 75 °C) and round crimping terminals. Crimp the crimping terminals with the crimping tool recommended by the terminal maker.

### A.2.6 Motor Overload Protection

The frequency inverters FR-D700 SC are equipped with a UL certified internal electronic thermal relay function. When using the electronic thermal relay as motor overload protection, set the rated motor current to Pr. 9 *Electronic thermal O/L relay*. (Refer to *page 28*)

#### NOTE

- Safety stop function is not certified by UL.



**HEADQUARTERS**

MITSUBISHI ELECTRIC EUROPE B.V. **EUROPE**  
 German Branch  
 Gothaer Straße 8  
**D-40880 Ratingen**  
 Phone: +49 (0)2102 / 486-0  
 Fax: +49 (0)2102 / 486-1120

MITSUBISHI ELECTRIC EUROPE B.V.-org.sl. **CZECH REP.**  
 Czech Branch  
 Avenir Business Park, Radlická 714/113a  
**CZ-158 00 Praha 5**  
 Phone: +420 - 251 551 470  
 Fax: +420 - 251-551-471

MITSUBISHI ELECTRIC EUROPE B.V. **FRANCE**  
 French Branch  
 25, Boulevard des Bouvets  
**F-92741 Nanterre Cedex**  
 Phone: +33 (0)1 / 55 68 55 68  
 Fax: +33 (0)1 / 55 68 57 57

MITSUBISHI ELECTRIC EUROPE B.V. **IRELAND**  
 Irish Branch  
 Westgate Business Park, Ballymount  
**IRL-Dublin 24**  
 Phone: +353 (0)1 4198800  
 Fax: +353 (0)1 4198890

MITSUBISHI ELECTRIC EUROPE B.V. **ITALY**  
 Italian Branch  
 Viale Colleoni 7  
**I-20041 Agrate Brianza (MB)**  
 Phone: +39 039 / 60 53 1  
 Fax: +39 039 / 60 53 312

MITSUBISHI ELECTRIC EUROPE B.V. **POLAND**  
 Poland Branch  
 Krakowska 50  
**PL-32-083 Balice**  
 Phone: +48 (0)12 / 630 47 00  
 Fax: +48 (0)12 / 630 47 01

MITSUBISHI ELECTRIC EUROPE B.V. **RUSSIA**  
 52, bid. 3 Kosmodamianskaya nab 8 floor  
**RU-115054 Moscow**  
 Phone: +7 495 721-2070  
 Fax: +7 495 721-2071

MITSUBISHI ELECTRIC EUROPE B.V. **SPAIN**  
 Spanish Branch  
 Carretera de Rubí 76-80  
**E-08190 Sant Cugat del Vallés (Barcelona)**  
 Phone: 902 131121 // +34 935653131  
 Fax: +34 935891579

MITSUBISHI ELECTRIC EUROPE B.V. **UK**  
 UK Branch  
 Travellers Lane  
**UK-Hatfield, Herts. AL10 8XB**  
 Phone: +44 (0)1707 / 27 61 00  
 Fax: +44 (0)1707 / 27 86 95

MITSUBISHI ELECTRIC CORPORATION **JAPAN**  
 Office Tower "Z" 14 F  
 8-12,1 chome, Harumi Chuo-Ku  
**Tokyo 104-6212**  
 Phone: +81 3 622 160 60  
 Fax: +81 3 622 160 75

MITSUBISHI ELECTRIC AUTOMATION, Inc. **USA**  
 500 Corporate Woods Parkway  
**Vernon Hills, IL 60061**  
 Phone: +1 847 478 21 00  
 Fax: +1 847 478 22 53

**EUROPEAN REPRESENTATIVES**

GEVA **AUSTRIA**  
 Wiener Straße 89  
**AT-2500 Baden**  
 Phone: +43 (0)2252 / 85 55 20  
 Fax: +43 (0)2252 / 488 60

TECHNIKON **BELARUS**  
 Oktyabrskaya 19, Off. 705  
**BY-220030 Minsk**  
 Phone: +375 (0)17 / 210 46 26  
 Fax: +375 (0)17 / 210 46 26

ESCO DRIVES & AUTOMATION **BELGIUM**  
 Culliganlaan 3  
**BE-1831 Diegem**  
 Phone: +32 (0)2 / 717 64 30  
 Fax: +32 (0)2 / 717 64 31

Koning & Hartman b.v. **BELGIUM**  
 Woluwelaan 31  
**BE-1800 Vilvoorde**  
 Phone: +32 (0)2 / 257 02 40  
 Fax: +32 (0)2 / 257 02 49

INEA RBT d.o.o. **BOSNIA AND HERZEGOVINA**  
 Aleja Lipa 56  
**BA-71000 Sarajevo**  
 Phone: +387 (0)33 / 921 164  
 Fax: +387 (0)33 / 524 539

AKHNATON **BULGARIA**  
 4, Andrei Ljapchev Blvd., PO Box 21  
**BG-1756 Sofia**  
 Phone: +359 (0)2 / 817 6000  
 Fax: +359 (0)2 / 97 44 06 1

INEA RBT d.o.o. **CROATIA**  
 Losinjska 4 a  
**HR-10000 Zagreb**  
 Phone: +385 (0)1 / 36 940 - 01 / -02 / -03  
 Fax: +385 (0)1 / 36 940 - 03

AutoCont C.S. s.r.o. **CZECH REPUBLIC**  
 Technologická 374/6  
**CZ-708 00 Ostrava-Pustkovec**  
 Phone: +420 595 691 150  
 Fax: +420 595 691 199

Beijer Electronics A/S **DENMARK**  
 Lykkegårdsvej 17  
**DK-4000 Roskilde**  
 Phone: +45 (0)46 / 75 76 66  
 Fax: +45 (0)46 / 75 56 26

Beijer Electronics Eesti OÜ **ESTONIA**  
 Pärnu mnt.160i  
**EE-11317 Tallinn**  
 Phone: +372 (0)6 / 51 81 40  
 Fax: +372 (0)6 / 51 81 49

Beijer Electronics OY **FINLAND**  
 Peltoie 37  
**FIN-28400 Ulvila**  
 Phone: +358 (0)207 / 463 540  
 Fax: +358 (0)207 / 463 541

UTEKO **GREECE**  
 5, Mavrogenou Str.  
**GR-18542 Piraeus**  
 Phone: +30 211 / 1206 900  
 Fax: +30 211 / 1206 999

MELTRADE Kft. **HUNGARY**  
 Fertő utca 14.  
**HU-1107 Budapest**  
 Phone: +36 (0)1 / 431-9726  
 Fax: +36 (0)1 / 431-9727

Beijer Electronics SIA **LATVIA**  
 Rītausmas iela 23  
**LV-1058 Rīga**  
 Phone: +371 (0)784 / 2280  
 Fax: +371 (0)784 / 2281

Beijer Electronics UAB **LITHUANIA**  
 Savanoriu Pr. 187  
**LT-02300 Vilnius**  
 Phone: +370 (0)5 / 232 3101  
 Fax: +370 (0)5 / 232 2980

**EUROPEAN REPRESENTATIVES**

ALFATRADE Ltd. **MALTA**  
 99, Paola Hill  
**Malta- Paola PLA 1702**  
 Phone: +356 (0)21 / 697 816  
 Fax: +356 (0)21 / 697 817

INTEHSIS srl **MOLDOVA**  
 bld. Traian 23/1  
**MD-2060 Kishinev**  
 Phone: +373 (0)22 / 66 4242  
 Fax: +373 (0)22 / 66 4280

HIFLEX AUTOM.TECHNIEK B.V. **NETHERLANDS**  
 Wolweverstraat 22  
**NL-2984 CD Ridderkerk**  
 Phone: +31 (0)180 - 46 60 04  
 Fax: +31 (0)180 - 44 23 55

Koning & Hartman b.v. **NETHERLANDS**  
 Haarderbergweg 21-23  
**NL-1101 CH Amsterdam**  
 Phone: +31 (0)20 / 587 76 00  
 Fax: +31 (0)20 / 587 76 05

Beijer Electronics AS **NORWAY**  
 Postboks 487  
**NO-3002 Drammen**  
 Phone: +47 (0)32 / 24 30 00  
 Fax: +47 (0)32 / 84 85 77

Fonseca S.A. **PORTUGAL**  
 R. João Francisco do Casal 87/89  
**PT - 3801-997 Aveiro, Esgueira**  
 Phone: +351 (0)234 / 303 900  
 Fax: +351 (0)234 / 303 910

Sirius Trading & Services srl **ROMANIA**  
 Aleea Lacul Morii Nr. 3  
**RO-060841 Bucuresti, Sector 6**  
 Phone: +40 (0)21 / 430 40 06  
 Fax: +40 (0)21 / 430 40 02

INEA RBT d.o.o. **SERBIA**  
 Izletnicka 10  
**SER-113000 Smederevo**  
 Phone: +381 (0)26 / 615 401  
 Fax: +381 (0)26 / 615 401

SIMAP s.r.o. **SLOVAKIA**  
 Jána Derku 1671  
**SK-911 01 Trenčín**  
 Phone: +421 (0)32 743 04 72  
 Fax: +421 (0)32 743 75 20

PROCONT, spol. s r.o. Prešov **SLOVAKIA**  
 Kúpeľná 1/A  
**SK-080 01 Prešov**  
 Phone: +421 (0)51 7580 611  
 Fax: +421 (0)51 7580 650

INEA RBT d.o.o. **SLOVENIA**  
 Stegne 11  
**SI-1000 Ljubljana**  
 Phone: +386 (0)1 / 513 8116  
 Fax: +386 (0)1 / 513 8170

Beijer Electronics AB **SWEDEN**  
 Box 426  
**SE-20124 Malmö**  
 Phone: +46 (0)40 / 35 86 00  
 Fax: +46 (0)40 / 93 23 01

Omni Ray AG **SWITZERLAND**  
 Im Schörl 5  
**CH-8600 Dübendorf**  
 Phone: +41 (0)44 / 802 28 80  
 Fax: +41 (0)44 / 802 28 28

GTS **TURKEY**  
 Bayraktar Bulvarı Nutuk Sok. No:5  
**TR-34775 Yukarı Dudullu-Ümraniye-İSTANBUL**  
 Phone: +90 (0)216 526 39 90  
 Fax: +90 (0)216 526 3995

CSC Automation Ltd. **UKRAINE**  
 4-B, M. Raskovoyi St.  
**UA-02660 Kiev**  
 Phone: +380 (0)44 / 494 33 55  
 Fax: +380 (0)44 / 494-33-66

**EURASIAN REPRESENTATIVES**

TOO Kazpromavtomatika **KAZAKHSTAN**  
 Ul. Zhambyla 28  
**KAZ-100017 Karaganda**  
 Phone: +7 7212 / 50 10 00  
 Fax: +7 7212 / 50 11 50

**MIDDLE EAST REPRESENTATIVE**

I.C. SYSTEMS LTD. **EGYPT**  
 23 Al-Saad-Al-Alee St.  
**EG-Sarayat, Maadi, Cairo**  
 Phone: +20 (0) 2 / 235 98 548  
 Fax: +20 (0) 2 / 235 96 625

SHERF Motion Techn. Ltd. **ISRAEL**  
 Rehov Hamerkava 19  
**IL-58851 Holon**  
 Phone: +972 (0)3 / 559 54 62  
 Fax: +972 (0)3 / 556 01 82

CEG INTERNATIONAL **LEBANON**  
 Cebaco Center/Block A Autostrade DORA  
**Lebanon - Beirut**  
 Phone: +961 (0)1 / 240 430  
 Fax: +961 (0)1 / 240 438

**AFRICAN REPRESENTATIVE**

CBI Ltd. **SOUTH AFRICA**  
 Private Bag 2016  
**ZA-1600 Isando**  
 Phone: + 27 (0)11 / 977 0770  
 Fax: + 27 (0)11 / 977 0761