

Click [here](#) for production status of specific part numbers.

MAX17853

14-Channel High-Voltage Data-Acquisition System

General Description

The MAX17853 is a flexible data-acquisition system for the management of high-voltage and low-voltage battery modules. The system can measure 14 cell voltages and a combination of six temperatures or system voltage measurements with fully redundant measurement engines in 263 μ s, or perform all inputs solely with the ADC measurement engine in 156 μ s. There are 14 internal balancing switches rated for > 300mA for cell-balancing current, each supporting extensive built-in diagnostics. Up to 32 devices can be daisy-chained to manage 448 cells and monitor 192 temperatures.

Cell and bus-bar voltages ranging from -2.5V to +5V are measured differentially over a 65V common-mode range, with a typical accuracy of 1mV (3.6V cell, 25°C). If oversampling is enabled, up to 128 measurements per channel can be averaged internally with 14-bit resolution and combined with digital post-processing IIR filtering for increased noise immunity. The system can shut itself down in the event of a thermal overload by measuring its own die temperature.

For robust communications, the system uses a Maxim battery-management UART or SPI protocol, and is optimized to support a reduced feature set of internal diagnostics and rapid-alert communication through both embedded communication and hardware-alert interfaces to support ASIL D and FMEA requirements.

Applications

- High-Voltage Battery Stacks
- Electric Vehicles (EVs)
- Hybrid Electric Vehicles (HEVs)
- Electric Bikes
- Battery-Backup Systems (UPS)
- Super-Cap Systems
- Battery-Powered Tools

Ordering Information appears at end of data sheet.

Benefits and Features

- 65V Operating Voltage
- Ultra-Low-Power Operation
 - Standby Mode: 2mA
 - Shutdown Mode: 2 μ A
- Redundant ADC and Comparator (COMP) Acquisitions
- Simultaneous Cell and Bus-Bar Voltage Acquisitions
- 14 Cell-Voltage Measurement Channels
 - 1mV Accuracy (3.6V, 25°C)
 - 2mV Accuracy (5°C to 40°C)
 - 4.5mV Accuracy (-40°C to +125°C)
- 14 Cell-Balancing Switches
 - > 300mA Software-Programmable Balancing Current
 - Optimized Driving and Parking Balancing Modes
 - Automated Balancing with Individual Cell Timers
 - Automated Balancing by Cell Voltage
 - Emergency Discharge Mode
- Six Configurable Auxiliary Inputs for Temperature, Voltage, or GPIO
- Integrated Die-Temperature Measurement
- Automatic Thermal Protection
- Individually Configurable Safety Alert
 - Overvoltage, Undertemperature Faults
 - Undervoltage, Overtemperature Faults
 - One Cell-Mismatch Alert
- Support ASIL D Requirements for Cell Voltage, Temperature, Communication
- Selectable UART, Dual UART, or SPI Interface
- Battery-Management UART Protocol
 - Daisy-Chain Up to 32 Devices
 - Capacitive Communication-Port Isolation
 - Up to 2Mbps Baud Rate (auto-detect)
 - 1.5 μ s Propagation Delay (per device)
 - Packet-Error Checking (PEC)
- Configurable Hardware-Alert Interfaces
- Factory-Trimmed Oscillator
 - No External Crystals Required
- 32-Bit Unique Device ID
- 64-Pin (10mm x 10mm) LQFP Package

TABLE OF CONTENTS

General Description	1
Applications	1
Benefits and Features	1
MAX17853 Simplified Application Diagrams	20
UART Interface with Single-Ended Alert	20
UART Interface with Differential Alert	21
SPI Interface with Single-Ended Alert	22
Absolute Maximum Ratings	23
Package Information	23
LQFP	23
Electrical Characteristics	24
Typical Operating Characteristics	33
Pin Configuration	35
Pin Description	36
Detailed Description	39
Block Diagrams	40
Terms, Definitions, and Data Conventions	43
Data Acquisition	43
Data Conventions	43
Factory Trimming	43
Factory-Programmed Device ID	44
Introduction	44
Flexible Battery-Pack Configuration	44
Flexible-Pack Interaction with Acquisitions	46
Power-Multiplexing Operation (Cell Balancing)	46
Flexible Pack Alert	46
Cell Inputs	47
Bus-Bar Inputs	48
Block-Voltage Input	49
Auxiliary Inputs	49
Auxiliary Inputs: Ratiometric Temperature Measurement	49
Ratiometric Auxiliary Input Range	52
Computing Temperature	52
Auxiliary Inputs: Absolute-Voltage Measurements	53
Absolute Auxiliary Input Range	53
Auxiliary Inputs: Mixed-Mode Measurements	53
Auxiliary-Input Protection	54

TABLE OF CONTENTS (CONTINUED)

GPIO Configuration	54
Operational Modes	54
Power-On (Standby Mode)	55
Shutdown-to-Standby State Diagram	56
Shutdown Mode	57
Shutdown State Diagram	58
Power-On and Shutdown Timing	61
Active Mode	65
Precision Internal Voltage References	65
Scan Methods	65
ADC Input Range	65
Comparator Input Range	66
Scan Configuration	66
ADC Configurations and Properties	66
ADC Polarity Configuration	66
ADC Acquisition	67
Pyramid Mode Acquisition Sequence	67
ADC Pyramid Mode Figures	67
ADC Acquisition Timing (Pyramid Mode)	70
Pyramid Mode Acquisition Time	70
Ramp-Mode Acquisition Sequence	71
ADC Ramp-Mode Figures	71
Ramp-Mode Acquisition Time	73
ADC Acquisition Timing (Ramp Mode)	73
ADC Acquisition Time Example	74
Comparator Configuration and Properties	74
Comparator-Scan Properties	74
Comparator Acquisition	74
Comparator-Acquisition Process	74
Comparator Thresholds	75
Comparator Acquisition Time	75
Comparator Acquisition Timing Example	75
Comparator Scan Figures	76
ADC+COMP Configuration and Properties	77
ADC+COMP Scan Mode	77
ADC+COMP Acquisition Time	77
ADC+COMP Scan Figures	78
ADC+COMP Acquisition Time Example	78

TABLE OF CONTENTS (CONTINUED)

On-Demand Calibration	80
Calibration Alerts	81
Oversampling	81
ADC Oversampling	81
Oversampling Watchdog Timeout	82
Comparator Oversampling	82
100Hz and 120Hz Filtering	83
Acquisition Watchdog Timeout	84
Data Control	85
Acquisition Data Transfer and Control	85
Calibration Data Control	86
IIR Filter	86
Filter Description	86
Filter Response	87
IIR Data Control	88
AMENDFILT and RDFILT	88
ALRTFILTSEL	88
IIR Initialization	88
Single-Buffer Mode	89
Double-Buffer Mode	90
Out-of-Scan Data Transfer	91
Cell Balancing with Embedded-Measurement Data Control	91
Measurement Alerts	91
Voltage Alerts	93
Cell Mismatch	94
Cell Statistics	94
Temperature Alerts	94
Cell Balancing	95
Cell-Balancing Mode Configurations	95
Manual Mode	96
AUTOBALSWDIS Feature	96
Manual Cell-Balancing Mode with FlexPack	97
Auto-Individual Mode	97
Auto-Group Mode	99
Emergency-Discharge Mode	99
Cell-Balancing Modes Summary	100
Auto-Even/Odd Cell Balancing	100

TABLE OF CONTENTS (CONTINUED)

Cell-Balancing Timer (CBTIMER)	102
CBRESTART Usage in Manual Mode	102
Emergency-Discharge Mode and CBDUTY Behavior	103
Notification Alerts Using CBNTFYCFG	103
Cell-Balancing Expiration Timer Summary	103
Cell-Balancing UV Detection	104
Cell-Balancing Measurement	105
Cell-Balancing IIR Filtering	105
Cell-Balancing Calibration	105
Calibration Out-of-Range During Cell Balancing	106
Transfer-Measurement Results Using CBSCAN	106
Cell-Balancing Completion	107
Automatic SHDNL Control Using HOLDSHDNL	107
Cell Balancing with Calibration	107
Cell-Balancing Switches	109
Cell-Balancing Current	109
Example: Autonomous-Cell Balancing by Time	109
Example: Autonomous-Cell Balancing with Programmable UV Threshold	110
Interface	111
Interface Options	111
UART Interface	111
Single-UART Interface with External Loopback	111
Single UART with Internal Loopback	112
Dual-UART Interface	112
Dual-UART Master Configuration	113
Dual-UART Master/Slave Interaction	114
UART Ports	115
UART Transmitter	115
UART Receiver	115
SHDNL Charge Pump	116
UART Rx Modes	117
Baud-Rate Detection	118
Tx Adaptive Mode for Single-Ended Mode	118
Battery-Management UART Protocol	118
Command Packet	118
Preamble Character	119
Data Characters	119

TABLE OF CONTENTS (CONTINUED)

Stop Character	120
UART Idle Mode	121
UART Communication Mode	121
Data Types	122
Command Bytes	122
Command-Byte Encoding	122
Register Addresses	122
Register Data	123
Data-Check Byte	123
PEC Byte	123
Alive-Counter Byte	123
Fill Bytes	124
Battery-Management UART	
Protocol Commands	124
HELLOALL Command	124
HELLOALL Operation in Dual-UART Configuration	124
HELLOALL Operation In a Single-UART Configuraiton	125
HELLOALL Address Lock	125
WRITEALL Command	126
WRITEDEVICE Command	126
READALL Command	127
READDEVICE Command	129
READBLOCK Command	130
DOWNHOST Command	132
UPHOST Command	132
ALERTPACKET Command	133
SPI Interface	134
Overview	134
System-Level Connection	135
Supported Transaction Alignments	136
Safety Pulup/Pulldown Resistors	136
SPI Transactions	136
SPI Write-Mode Transcations	136
SPI Write-Mode Input Data Format	136
Write Bit — R/WB = 0 (DI[31]).	136
Address — A[7:0] (DI[30:23]).	136
Address Cyclic-Redundancy Check — CRCA[2:0] (DI[22:20]).	136

TABLE OF CONTENTS (CONTINUED)

Input Data — DIN[15:0] (DI[19:4])	137
Repeated-Write Bit — R/WB' = 0 (DI3)	137
Input Data Cyclic-Redundancy Check — CRCD[2:0] (DI[2:0])	137
SPI Write-Mode Output Data Format	137
Status Information — STAT[4:0] (DO[31:27])	137
Status Cyclic-Redundancy Check — CRCS[2:0] (DO[26:24])	137
Address Confirmation — A'[7:0] (DO[23:16])	137
Input Data Confirmation — DIN'[7:0] (DO[15:0])	137
SPI Write-Mode Qualification Checks	137
SPI Read-Mode Transactions	138
SPI Read-Mode Input-Data Format	138
Read Bit — R/WB = 1 (DI[31]):	138
Address — A[7:0] (DI[30:23])	138
Address Cyclic Redundancy Check — CRCA[2:0] (DI[22:20])	138
Input Data — DIN[15:0] (DI[19:4])	139
Repeated-Read Bit — R/WB' = 1 (DI[3]).	139
Input-Data Cyclic-Redundancy Check — CRCD[2:0] (DI[2:0])	139
SPI Read-Mode Output-Data Format	139
Status Information — STAT[4:0] (DO[31:27])	139
Status Cyclic-Redundancy Check — CRCS[2:0] (DO[26:24])	139
Read Confirmation Bits — F\h (DO[23:20])	139
Output Data — DOUT[15:0] (DO[19:4])	139
Read OK Bit — ROK (DO[3])	139
Output-Data Cyclic-Redundancy Check — CRCO[2:0] (DO[2:0])	139
SPI Read-Mode Qualification Checks	140
General-Transaction Information (SPI)	140
Status and Status CRC Output Data	140
Status Information — STAT[4:0] (DO[31:27])	140
SPI ALERT Bit-Masking Operations	141
Status Cyclic Redundancy Check — CRCS[2:0] (DO[26:24])	141
SPI CRC Calculations	141
SPI CRC Pseudocode Example	143
SPI Timeout Behavior	144
Alert Interface	144
UART-Mode Alert Detection (UARTSEL=1'b1)	146
SPI Mode Alert Operation (UARTSEL=1'b0)	146
Alert Interface Masking Operations	146

TABLE OF CONTENTS (CONTINUED)

Alert Packet Status Masking	146
Alert-Masking TOPCELL1/2	147
Low-Voltage Regulator	148
HV Charge Pump	148
Oscillators	150
Diagnostics	150
ALERTOUT Pin-to-Pin Short Diagnostic	150
CELL Pin Open Diagnostics	150
Die-Temperature Measurement	151
Die-Temperature Alert	153
V _{AA} Diagnostic Measurement	153
ALTREF Diagnostic Measurement	154
Comparator Signal-Path Diagnostic Measurement	155
Cell Gain-Calibration-Diagnostic Measurement	159
Offset-Calibration Diagnostic	159
THRM Offset-Calibration Diagnostic	161
LSAMP Offset-Diagnostic Measurement	161
Zero-Scale ADC Diagnostic Measurement	161
Full-Scale ADC Diagnostic Measurement	163
DAC 1/4 Scale Diagnostic	163
DAC 3/4 Scale Diagnostic	164
BALSW Diagnostics	164
BALSW Short Diagnostic	165
BALSW Open Diagnostic	167
Even/Odd Sense-Wire Open Diagnostics	169
Examples of Normal Sense-Wire Operation	172
Examples of Broken Sense-Wire Fault Detection	173
Sense-Wire Open-Fault-Detection Results	173
Examples of Broken Internal Switch and Trace-Fault Detection	175
ADC End-of-Scan Diagnostics	175
Register Map	175
MAX17853 User Register Map	175
Register Map Usage Guidelines	175
Interface Protocol Errors	175
Reserved Registers	175
Unused Bitfields	175
STATUS Registers	176

TABLE OF CONTENTS (CONTINUED)

GENERAL CONFIGURATION Registers	177
ALERT CONFIGURATION Registers	178
THRESHOLD Registers	178
DIAGNOSTIC THRESHOLD Registers	180
CELL DATA Registers	180
TOTAL DIAG AUX DATA Registers	181
SCAN SETTINGS Registers	181
SCAN CONTROL Registers	182
DIAGNOSTIC SETTINGS Registers	182
DIAGNOSTIC CONTROL Registers	182
CELL-BALANCING Registers	182
ROM SUPPORT Registers	184
Reserved Bitfields	176
Register Blocks and Transaction-Reject Behavior	176
Register Details	185
VERSION	185
ADDRESS	185
STATUS1	187
STATUS2	190
STATUS3	193
FMEA1	194
FMEA2	196
ALRTSUM	198
ALRTOVCELL	200
ALRTUVCELL	201
MINMAXCELL	201
ALRTAUXPRTCTREG	202
ALRTAUXOVREG	203
ALRTAUXUVREG	204
ALRTCOMPUVREG	205
ALRTCOMPAUXOVREG	205
ALRTCOMPAUXUVREG	206
ALRTBALSWREG	207
SWACTION	207
DEVCFG1	208
DEVCFG2	212
AUXGPIOCFG	213
GPIOCFG	214

TABLE OF CONTENTS (CONTINUED)

PACKCFG	216
ALRTIRQEN	217
ALRTOVEN	220
ALRTUVEN	220
ALRTAUXOVEN	221
ALRTAUXUVEN	222
ALRTCALTST	222
OVTHCLRREG	223
OVTHSETREG	224
UVTHCLRREG	224
UVTHSETREG	225
MSMTCHREG	225
BIPOVTHCLRREG	226
BIPOVTHSETREG	226
BIPUVTHCLRREG	227
BIPUVTHSETREG	227
BLKOVTHCLRREG	228
BLKOVTHSETREG	228
BLKUVTHCLRREG	229
BLKUVTHSETREG	229
AUXROVTHCLRREG	230
AUXROVTHSETREG	230
AUXRUVTHCLRREG	231
AUXRUVTHSETREG	231
AUXAOVTHCLRREG	232
AUXAOVTHSETREG	232
AUXAUVTHCLRREG	233
AUXAUVTHSETREG	233
COMPOVTHREG	234
COMPUVTHREG	234
COMPAUXROVTHREG	235
COMPAUXRUVTHREG	235
COMPAUXAOVTHREG	236
COMPAUXAUVTHREG	236
COMPOPNTHREG	237
COMPAUXROPNTHREG	237
COMPAUXAOPNTHREG	238
COMPACCOVTHREG	238

TABLE OF CONTENTS (CONTINUED)

COMPACCUVTHREG	239
BALSHRTTHRREG	239
BALLOWTHRREG	240
BALHIGHTHRREG	241
CELL1REG	241
CELL2REG	242
CELL3REG	242
CELL4REG	243
CELL5REG	243
CELL6REG	244
CELL7REG	244
CELL8REG	245
CELL9REG	245
CELL10REG	246
CELL11REG	246
CELL12REG	247
CELL13REG	247
CELL14REG	248
BLOCKREG	248
TOTALREG	249
DIAG1REG	249
DIAG2REG	250
AUX0REG	250
AUX1REG	251
AUX2REG	251
AUX3REG	252
AUX4REG	252
AUX5REG	253
POLARITYCTRL	253
AUXREFCTRL	254
AUXTIMEREG	255
ACQCFG	256
BALSWDLY	257
MEASUREEN1	258
MEASUREEN2	258
SCANCTRL	259
ADCTEST1AREG	262
ADCTEST1BREG	263

TABLE OF CONTENTS (CONTINUED)

ADCTEST2AREG	264
ADCTEST2BREG	264
DIAGCFG	265
CTSTCFG	268
AUXTSTCFG	269
DIAGGENCFG	269
BALSWCTRL	270
BALEXP1	271
BALEXP2	272
BALEXP3	272
BALEXP4	273
BALEXP5	273
BALEXP6	274
BALEXP7	274
BALEXP8	275
BALEXP9	275
BALEXP10	276
BALEXP11	276
BALEXP12	277
BALEXP13	277
BALEXP14	278
BALAUTOUVTHR	278
BALDLYCTRL	279
BALCTRL	280
BALSTAT	282
BALUVSTAT	283
BALDATA	284
ID1	285
ID2	285
OTP2	286
OTP3	286
OTP4	287
OTP5	287
OTP6	288
OTP7	288
OTP8	289
OTP9	289

TABLE OF CONTENTS (CONTINUED)

OTP10	290
OTP11	290
OTP12	291
Calibration-Alert Diagnostics	292
Supply Connection Diagnostics	293
Applications Information	295
Vehicle Applications	295
Battery-Management Systems	295
Daisy-Chain System	295
Distributed CAN Systems	295
Standard Module Configuration	295
Power-Supply Connection	295
Connecting Cell Inputs	295
Flexible Pack Configuration	296
Power Supply, Cell Input Configuration	296
External Cell Balancing	298
External Cell-Balancing using FET Switches	299
External Cell-Balancing Using BJT Switches	299
External Cell-Balancing Short-Circuit Detection	300
UART Interface	301
High-Z Idle Mode	301
UART Supplemental ESD Protection	301
Single-Ended Rx Mode	301
UART Isolation	301
UART Transformer Isolation	308
UART Optical Isolation	309
SPI Interface	309
ALERT Interface	309
Device Initialization Sequence	309
Error Checking	309
PEC Errors	309
PEC Calculations	309
PEC Calculation Pseudocode	311
ROMCRC Calculation	312
PCB Layout Recommendations	313
Layout Procedure	313
Ordering Information	314
Revision History	315

LIST OF FIGURES

Figure 1. MAX17853 Functional Block Diagram	40
Figure 2. MAX17853 ESD Diodes	41
Figure 3. MAX17853 Analog Front-End	42
Figure 4. Flexible-Pack Configuration for 12-Cell Pack on 14-Channel CMC	45
Figure 5. Flexible-Pack Power-On Timing	46
Figure 6. Cell Signal Path	47
Figure 7. Bus-Bar Switch Configuration	48
Figure 8. Block-Measurement Path	49
Figure 9. Auxiliary Application Circuit	50
Figure 10. Auxiliary-Temperature Measurements	50
Figure 11. Operational-Mode State Diagram	55
Figure 12. Power-On Sequence	56
Figure 13. Shutdown Sequence	58
Figure 14. UART Operation (Shutdown Timing)	59
Figure 15. SPI Operation (Shutdown Timing)	60
Figure 16. Power-On Timing (UART-Communication Control)	61
Figure 17. Power-On Shutdown Timing (SPI Directed Control)	62
Figure 18. Power-On and Shutdown Timing (UART Control)	63
Figure 19. Power-On and Shutdown Timing (SPI Control)	64
Figure 20. Acquisition (SCANCFG=0h, SCANMODE=0, OVSAMPL=0h, ALTMUXSEL=0, BLOCKEN=1, DIAGSEL1 > 0h, DIAGSEL2 > 0h, AUXEN=3Fh)	67
Figure 21. Acquisition (SCANCFG=0h, SCANMODE=0, OVSAMPL = 0h, TOPCELL1/2 = 14, ALTMUXSEL=1, BLOCKEN=1, DIAGSEL1 > 0h, DIAGSEL2 > 0h, AUXEN=3F)	68
Figure 22. Acquisition - SCANCFG=0h, SCANMODE=0, OVSAMPL > 0h, ALTMUXSEL=0, BLOCKEN=1, DIAGSEL1 > 0h, DIAGSEL2 > 0h, AUXEN=3Fh	68
Figure 23. Acquisition (SCANCFG=0h, SCANMODE=0, OVSAMPL > 0h, ALTMUXSEL=0, BLOCKEN=1, DIAGSEL1 > 0h, AUXEN=03h, FOSR > 0h)	69
Figure 24. Acquisition (SCANCFG=0h, SCANMODE=1, OVSAMPL=0h, ALTMUXSEL=0, BLOCKEN=1, DIAGSEL1 > 0h, DIAGSEL2 > 0h, AUXEN=3Fh)	71
Figure 25. Acquisition (SCANCFG=0h, SCANMODE=1, OVSAMPL = 0h, TOPCELL1/2=14, ALTMUXSEL=1, BLOCKEN=1, DIAGSEL1 > 0h, DIAGSEL2 > 0h, AUXEN=3Fh)	72
Figure 26. Comparator Single-Scan Mode	76
Figure 27. Comparator Single-Scan with Oversampling	76
Figure 28. Simultaneous ADC+COMP Scan Mode	78
Figure 29. Simultaneous ADC+COMP Scan With Oversampling	79
Figure 30. On-Demand Calibration Block Diagram	81
Figure 31. 100Hz Notch Filter	83
Figure 32. 120Hz Notch Filter	83
Figure 33. Acquisition-Mode Flowchart	84

LIST OF FIGURES (CONTINUED)

Figure 34. Data-Flow Diagram	85
Figure 35. IIR Filter Algorithm	86
Figure 36. 100mV IIR Step Response	87
Figure 37. Single-Buffer Data Transfer	89
Figure 38. Double-Buffer Data Transfer	90
Figure 39. Cell Voltage-Alert Thresholds	93
Figure 40. Logic Diagram when Balancing Switches are Disabled	97
Figure 41. AUTOBALSWDIS Measurement Settling	98
Figure 42. Auto Even/Odd Cell Balancing without UV Detection	101
Figure 43. Auto Even/Odd Cell Balancing with UV Detection, ADC with OVSAMPL	101
Figure 44. Cell-Balancing Expiration Timer	103
Figure 45. Cell-Balancing UV-Threshold Crossing	104
Figure 46. Cell Balancing with No Calibration	106
Figure 47. Cell Balancing with Calibration	107
Figure 48. Cell-Balancing Stop Control	108
Figure 49. SHDNL Pullup Control	108
Figure 50. Internal Cell-Balancing Switches	109
Figure 51. Typical Balancing-Current Performance	110
Figure 52. Single UART with External Loopback	111
Figure 53. Single UART with Differential Alert Interface	112
Figure 54. Dual-UART Interface	113
Figure 55. Dual-UART Master/Slave Interaction (Timing Considerations)	114
Figure 56. Dual-UART Command Timing	114
Figure 57. UART Transmitter	115
Figure 58. UART Receiver	115
Figure 59. SHDNL Charge Pump	116
Figure 60. Command Packet	118
Figure 61. Preamble Character	119
Figure 62. Data Characters	119
Figure 63. Stop Character	120
Figure 64. Communication Mode	121
Figure 65. SPI Timing Diagram	134
Figure 66. SPI Device Connection	135
Figure 67. SPI Supported Transaction Alignments	135
Figure 68. SPI Write-Mode Transaction Format	136
Figure 69. SPI Read-Mode Transaction Format	138
Figure 70. SPI CRC Calculation	142
Figure 71. UART-Mode Alert-Detection Timing Diagram	145

LIST OF FIGURES (CONTINUED)

Figure 72. Low-Voltage Regulator and Thermal-Shutdown Circuit	147
Figure 73. HV Charge Pump	149
Figure 74. Die-Temperature Measurement	152
Figure 75. V_{AA} Diagnostic	153
Figure 76. ALTREF Diagnostic.	154
Figure 77. Comparator Signal Path to ADC.	155
Figure 78. Comparator Accuracy Diagnostic Path.	157
Figure 79. Comparator Accuracy End of Scan Measurement.	158
Figure 80. Cell Gain Calibration-Diagnostic Measurement	159
Figure 81. Offset-Calibration Diagnostic	160
Figure 82. THRM Offset-Calibration Diagnostic	160
Figure 83. LSAMP Offset Diagnostic.	161
Figure 84. ADC Zero-Scale Diagnostic	162
Figure 85. Full-Scale ADC Diagnostic Measurement	162
Figure 86. DAC 1/4 and 3/4 Diagnostic	163
Figure 87. Balancing Switch Short.	165
Figure 88. BALSW Short-Diagnostic Chart	166
Figure 89. BALSW Open Diagnostic	168
Figure 90. Sense-Wire Open-Diagnostic Flow	168
Figure 91. Cell Sense-Wire Open-Diagnostic Operations (Normal Operation).	169
Figure 92. Cell Sense-Wire Open-Diagnostic Operations (Normal Operation, Including Bus Bars)	170
Figure 93. Cell Sense-Wire Open-Diagnostic Operations (Example with Odd Sense-Wire Fault).	171
Figure 94. Cell Sense-Wire Open-Diagnostic Operations (Example with Even Sense-Wire Fault)	171
Figure 95. Cell Sense-Wire Open-Diagnostic Operations (Example with Broken BALSW or Internal Trace)	174
Figure 96. Electric Vehicle System	292
Figure 97. Daisy-Chain System	293
Figure 98. Distributed System	294
Figure 99. Power-Supply Connection	295
Figure 100. External-Balancing FET	296
Figure 101. External Cell-Balancing BJT	297
Figure 102. UART Connection	298
Figure 103. High-Z Idle Mode Application Circuit	299
Figure 104. External ESD Protection for UART Tx Ports	299
Figure 105. External ESD Protection for UART Rx Ports	300
Figure 106. Application Circuit for Single-Ended UART Mode	300
Figure 107. UART Transformer Isolation	301
Figure 108. UART Optical Isolation	302
Figure 109. 5V SPI Supply from System	303

LIST OF FIGURES (CONTINUED)

Figure 110. 3.3V SPI Supply from Device V_{AA} LDO	304
Figure 111. Single-End ALERT Interface in UART Mode	305
Figure 112. Single-End ALERT Interface in SPI mode - Active Drive	306
Figure 113. Single-End ALERT Interface in SPI mode - Passive Drive	307
Figure 114. Device Initialization Sequence	308
Figure 115. PEC CRC Calculation	310
Figure 116. ROMCRC Calculation	313

LIST OF TABLES

Table 1. System Blocks	39
Table 2. Data-Acquisition Process	43
Table 3. Numeric Conventions	43
Table 4. THRM Output	51
Table 5. AUXTIME	51
Table 6. Auxiliary-Temperature Input Range: ADC	52
Table 7. Auxiliary-Temperature Input Range: Comparator	52
Table 8. Auxiliary-Voltage Input Range: ADC	53
Table 9. Auxiliary-Voltage Input Range: Comparator	53
Table 10. GPIO/Auxiliary Enable Selection	54
Table 11. GPIO Configuration	54
Table 12. Shutdown Timing	57
Table 13. ADC Input Range	65
Table 14. Comparator Input Range	66
Table 15. ADC Pyramid Mode (SCANMODE = 0) Acquisition Time	70
Table 16. ADC Ramp Mode (SCANMODE = 1) Acquisition Time	73
Table 17. ADC Acquisition Time Examples (with AUXTIME[9:0] = 000h)	74
Table 18. Comparator Acquisition Time	75
Table 19. Comparator Acquisition-Time Examples (with AUXTIME[9:0] = 000h)	75
Table 20. ADC+COMP Acquisition Time	77
Table 21. ADC+COMP Acquisition Time Examples (with AUXTIME[9:0] = 000h)	78
Table 22. Measurement Path Calibration Alerts	80
Table 23. Comparator Faults for Alerts vs. Oversampling	82
Table 24. Watchdog-Timeout Duration	82
Table 25. FOSR Notch-Filter Setting	83
Table 26. IIR 100mV Step Response Settling	87
Table 27. IIR Data-Control Settings	88
Table 28. Measurement Alerts	91

LIST OF TABLES (CONTINUED)

Table 29. Set- and Clear-Threshold Selection	92
Table 30. Temperature-Alert Threshold	94
Table 31. Cell-Balancing Register Write Behavior when Cell Balancing is Selected	96
Table 32. Cell-Balancing Mode	100
Table 33. Emergency-Discharge Mode	103
Table 34. Cell-Balancing Measurement Enable.	105
Table 35. Cell-Balancing Calibration Selection	105
Table 36. Calibration Frequency	106
Table 37. UART Configurations	111
Table 38. UART Rx Modes (Post ALRTRST Being Cleared)	117
Table 39. UART Rx Modes (Prior to ALRTRST Being Cleared)	117
Table 40. Data Character Description	120
Table 41. Data Types	121
Table 42. Command Packet Types	122
Table 43. Battery-Management Protocol (Command-Byte Encoding)	122
Table 44. Data-Check Byte	123
Table 45. HELLOALL Command Packet	125
Table 46. HELLOALL Up-Path Sequencing.	125
Table 47. HELLOALL Down-Path Sequencing.	125
Table 48. WRITEALL Sequencing (Unchanged by Daisy-Chain)	126
Table 49. WRITEDEVICE Sequencing (Unchanged by Daisy-Chain).	126
Table 50. READALL Command Sequencing In Single-UART or Dual-UART Up Path (z = Number of Devices).	127
Table 51. READALL Command Sequencing In Dual-UART Down Path (z = Number of Devices)	128
Table 52. READDEVICE Sequencing In Single-UART or Dual-UART Up Path	129
Table 53. READDEVICE Sequencing In Dual-UART Down Path	129
Table 54. READBLOCK Sequencing In Single-UART or Dual-UART Up Path (Block Size = 1)	130
Table 55. READBLOCK Sequencing In Single-UART or Dual-UART Up Path (Block Size = 1)	130
Table 56. READBLOCK Sequencing In Dual-UART Down Path (Block Size = 2)	131
Table 57. READBLOCK Sequencing In Single-UART or Dual-UART Down Path (Block Size = 2)	131
Table 58. DOWNHOST Sequencing (z = Total Number of Devices).	132
Table 59. UPHOST Sequencing (z = total number of devices)	133
Table 60. ALERTPACKET Sequencing	133
Table 61. SPI CRC Operation Summary	141
Table 62. Alert-Interface Configuration in UART Mode.	144
Table 63. Alert Output Driver Configuration	145
Table 64. Low-Voltage Regulator Operating Characteristics.	147

LIST OF TABLES (CONTINUED)

Table 65. Low-Voltage Regulator Diagnostic	147
Table 66. HV Charge-Pump Diagnostics	148
Table 67. Oscillator Diagnostics	148
Table 68. Summary of Built-In Diagnostics	150
Table 69. Comparator Signal-Path Diagnostic Verification Ranges	156
Table 70. BALSWS Diagnostic	164
Table 71. BALSWS-Short Diagnostics Operation	165
Table 72. BALSWS Short Diagnostic Auto-Configuration	167
Table 73. BALSWS Open-Diagnostic Operation	167
Table 74. BALSWS Open-Diagnostic Auto-Configuration	167
Table 75. Sense-Wire Open-Diagnostic Automatic Configuration Overrides	169
Table 76. Odd Sense-Wire Open-Measurement Results for Broken Sense Wires	172
Table 77. Even Sense-Wire Open-Measurement Results for Broken Sense Wires	172
Table 78. Odd and Even Sense-Wire Open-Measurement Results Overlay for Broken Sense Wires	173
Table 79. Odd and Even Sense-Wire Open-Measurement Results Overlay for Broken Sense Wires	174
Table 80. FET-Balancing Components	296
Table 81. BJT Balancing Components	297

MAX17853 Simplified Application Diagrams

UART Interface with Single-Ended Alert

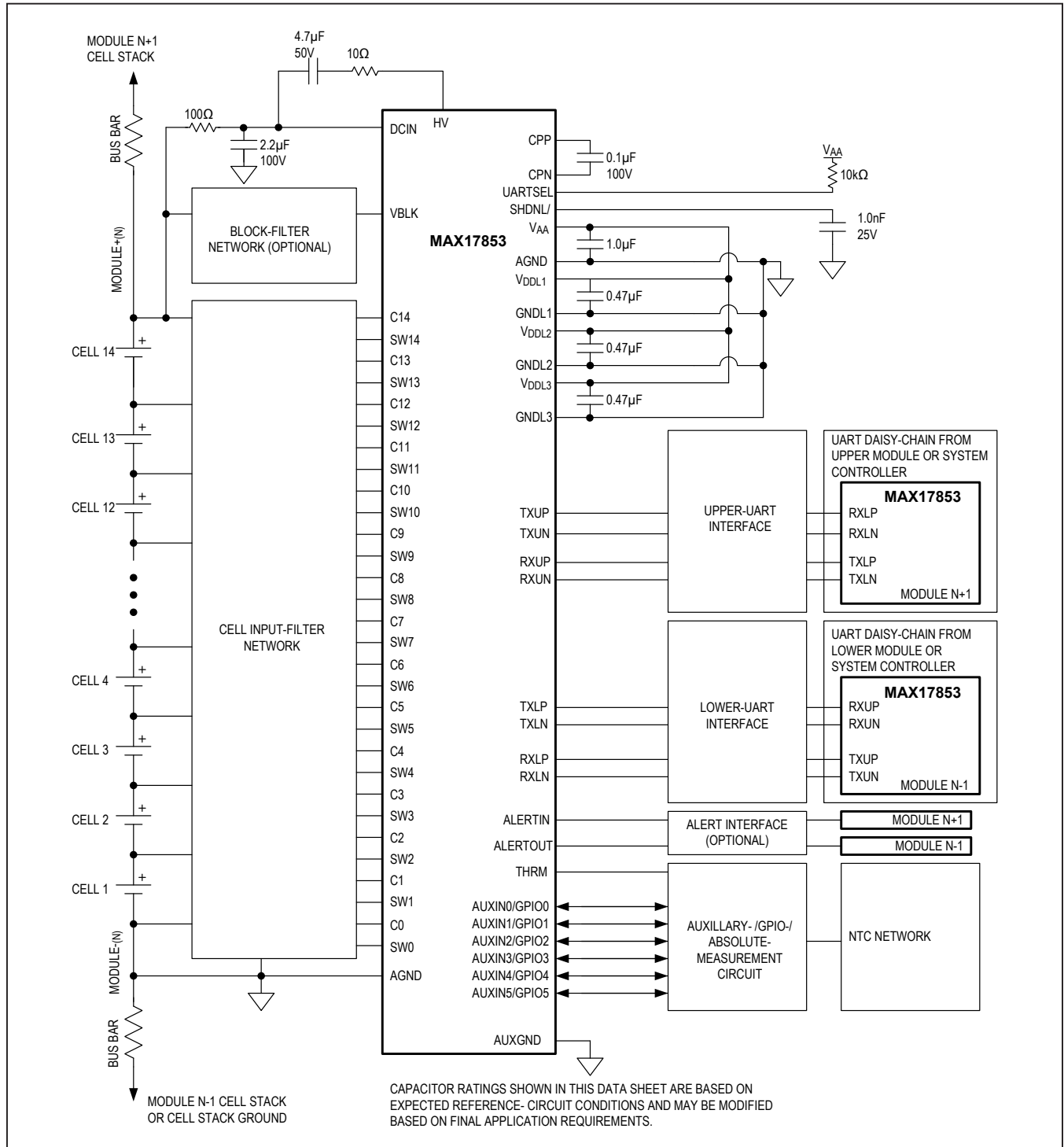

MAX17853 Simplified Application Diagrams (continued)

UART Interface with Differential Alert

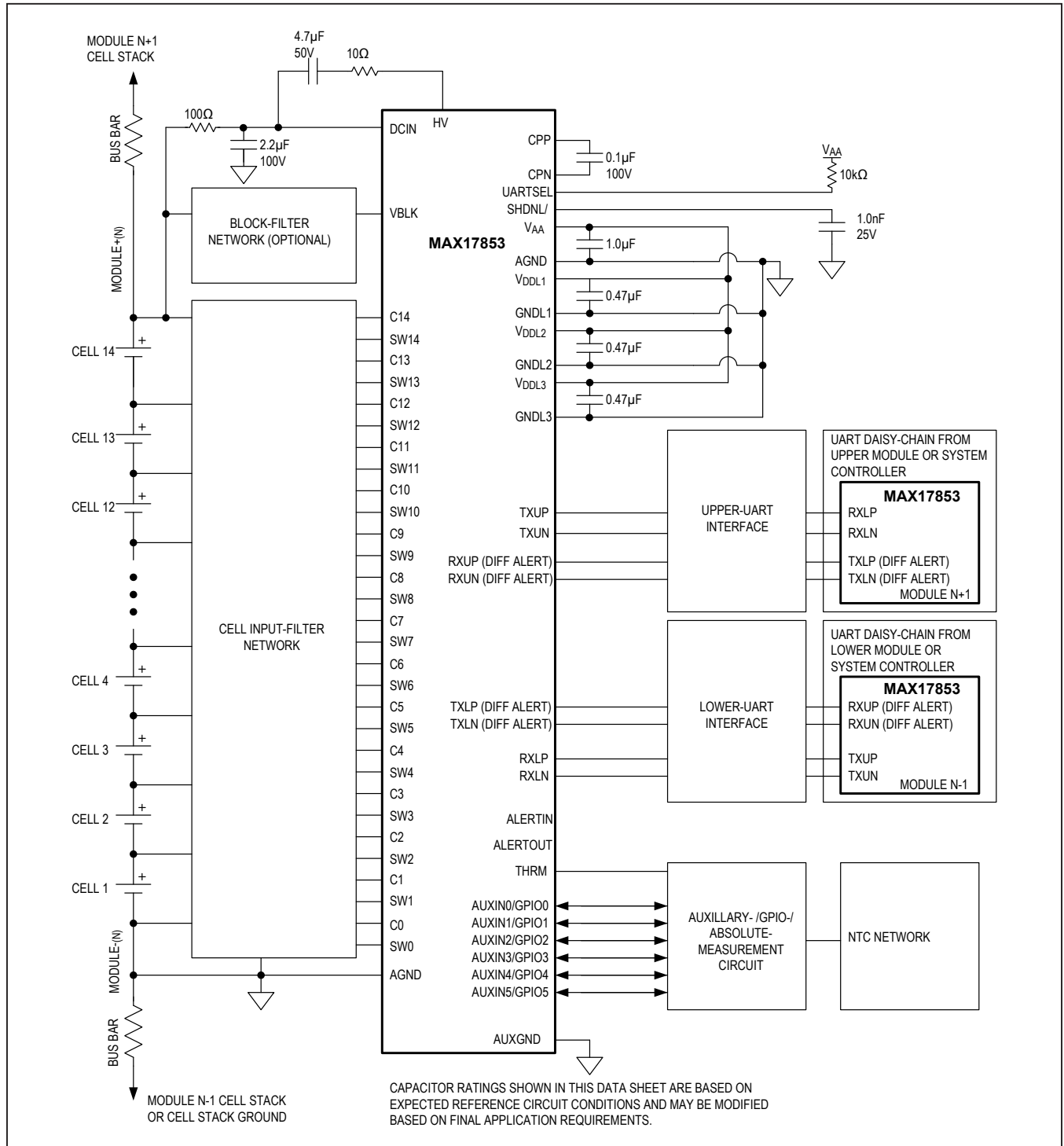

MAX17853 Simplified Application Diagrams (continued)

SPI Interface with Single-Ended Alert

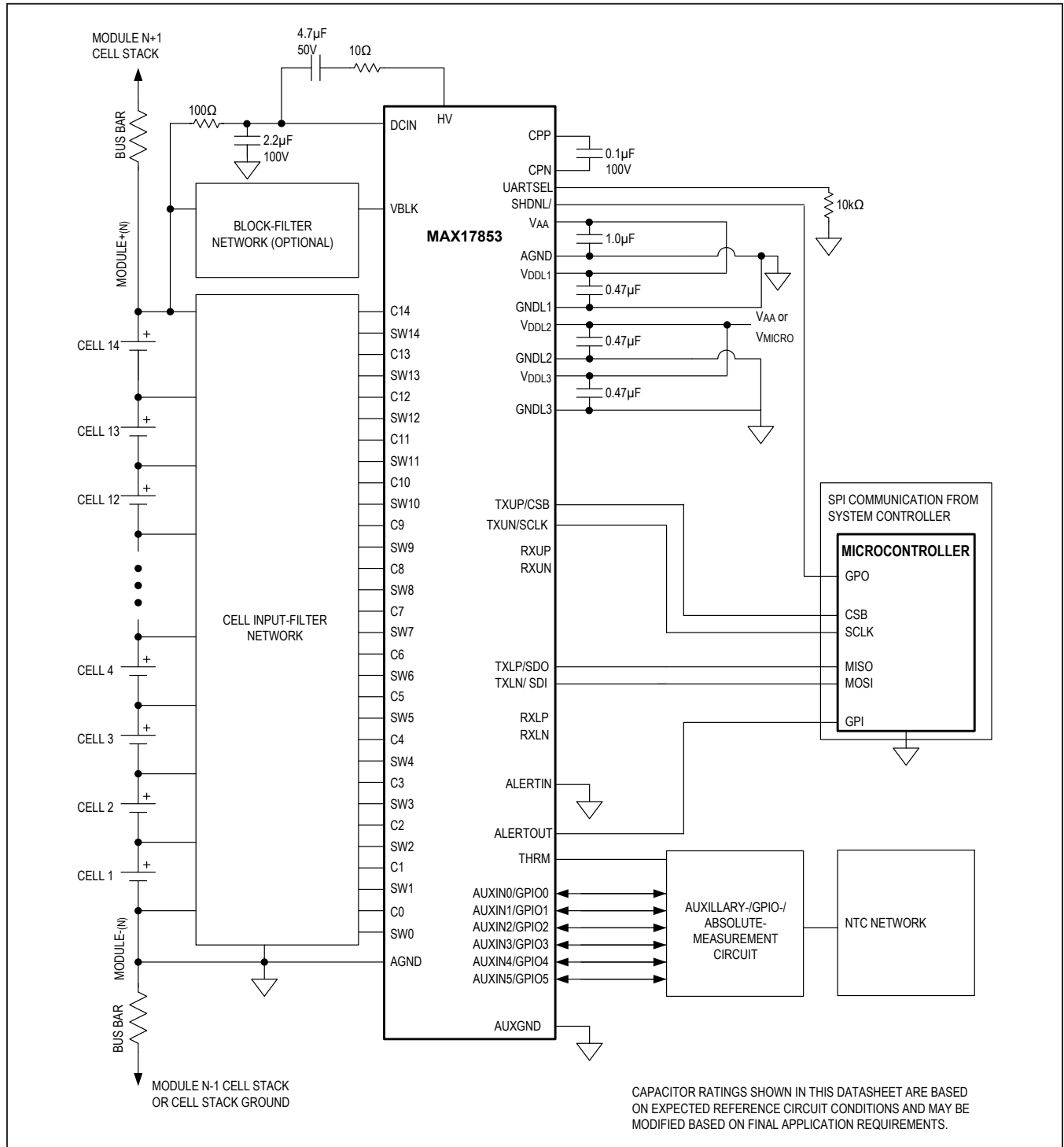

Absolute Maximum Ratings

HV to AGND	-0.3V to +80V
DCIN, SWn, VBLK, Cn to AGND	-0.3V to min (V _{HV} + 0.3V or 72V)
Cn to Cn-1	-72V to +72V
SWn to SWn-1	-0.3V to +16V
V _{AA} to AGND	-0.3V to +4V
V _{DDL2} , V _{DDL3} to V _{AA}	-0.3V to +6.0V
V _{DDL1} to GNDL1	-0.3V to +4V
V _{DDL2} to GNDL2	-0.3V to +6V
V _{DDL3} to GNDL3	-0.3V to +6V
V _{AA} to V _{DDL1}	-0.3V to +0.3V
AGND to GNDL1, GNDL2, GNDL3	-0.3V to +0.3V
AGND to AUXGND	-0.3V
GPIO _n /AUXIN _n	-0.3V to V _{DDL2} + 0.3V
THRM to AGND	-0.3V to V _{AA} + 0.3V
SHDNL to AGND	-0.3V to V _{DCIN} + 0.3V

RXLP, RXLN, RXUP, RXUN, ALERTIN to AGND	-30V to +30V
TXLP, TXLN, ALERTOUT to GNDL2	-0.3V to +6V
TXUP, TXUN to GNDL3	-0.3V to +6V
UARTSEL to AGND	-0.3V to V _{DDL1} + 0.3V
CPP to AGND	V _{DCIN} - 1V to V _{HV} + 1V
CPN to AGND	-0.3V to V _{DCIN} + 0.3V
Maximum Continuous Current into Any Pin (Note 1)	-20mA to +20mA
Maximum Continuous Current into SWn Pin (Note 2)	-650mA to +650mA
Maximum Average Power for ESD Diodes (Note 3)	14.4W/√T
Package Continuous Power (Note 4)	mW to 2000mW
Operating Temperature Range	-40°C to +125°C
Storage Temperature Range	-55°C to +150°C
Junction Temperature (Continuous)	150°C
Soldering Lead Temperature (10s max)	300°C

Note 1: Balancing switches disabled.

Note 2: One balancing switch enabled, 60s (max).

Note 3: Average power for time period *T*, where *T* is the time constant (in μs) of the transient diode current during hot-plug event. For, example, if *T* is 330μs, the maximum average power is 0.793W. Peak current must never exceed 2A. Actual average power during hot-plug must be calculated from the diode current waveform for the application circuit and compared to the maximum rating.

Note 4: Multilayer board. For T_A > +70°C, derate 25mW/°C.

Stresses beyond those listed under "Absolute Maximum Ratings" may cause permanent damage to the device. These are stress ratings only, and functional operation of the device at these or any other conditions beyond those indicated in the operational sections of the specifications is not implied. Exposure to absolute maximum rating conditions for extended periods may affect device reliability.

Package Information

LQFP

Package Code	C64+18
Outline Number	21-0083
Land Pattern Number	90-0141
Thermal Resistance, Four-Layer Board:	
Junction to Ambient (θ _{JA})	40°C/W
Junction to Case (θ _{JC})	8°C/W

For the latest package outline information and land patterns (footprints), go to www.maximintegrated.com/packages. Note that a "+", "#", or "-" in the package code indicates RoHS status only. Package drawings may show a different suffix character, but the drawing pertains to the package regardless of RoHS status.

Package thermal resistances were obtained using the method described in JEDEC specification JESD51-7, using a four-layer board. For detailed information on package thermal considerations, refer to www.maximintegrated.com/thermal-tutorial.

Electrical Characteristics

($V_{DCIN} = +56V$, $T_A = T_{MIN}$ to T_{MAX} unless otherwise noted, where $T_{MIN} = -40^{\circ}C$ and $T_{MAX} = +125^{\circ}C$. Typical values are at $T_A = +25^{\circ}C$. Operation is with the recommended application circuit.) (Note 5)

PARAMETER	SYMBOL	CONDITIONS	MIN	TYP	MAX	UNITS
POWER REQUIREMENTS						
Supply Voltage, DCIN	V_{DCIN}		9		65	V
Supply Voltage, V_{DDL2} , V_{DDL3}	V_{DDL2} , V_{DDL3}		V_{AA}		5.5	V
DCIN Current, Shutdown Mode	I_{DCSHDN}	$V_{SHDNL} = 0V$		0.1		μA
DCIN Current, Standby Mode (Note 6)	I_{DCSTBY}	$V_{SHDNL} > 1.8V$, UART in idle mode, not in acquisition mode, balance switches, test current sources, and alert interface disabled	1.7	2.3	2.9	mA
DCIN Current, ADC Acquisition Mode (Note 6)	I_{DC_ADC}	All cell and auxiliary measurements enabled, $OVSAMPL[2:0]=000b$		5.4	8.0	mA
DCIN Current, COMP Acquisition Mode (Note 6)	I_{DC_COMP}	All cell and auxiliary measurements enabled		6	7.7	mA
DCIN Current, ADC + COMP Acquisition Mode (Note 6)	$I_{DC_ADCCOMP}$	All cell and auxiliary measurements enabled		6.8	8.4	mA
DCIN Incremental Current, SPI Communication Mode (Note 6)	I_{DCCOMM_SPI}	$V_{SHDNL} > 1.8V$, all channels disabled, all test current sources disabled, acquisition disabled		170	300	μA
DCIN Incremental Current, UART Communication Mode (Note 6)	I_{DCCOMM_UART}	Baud rate = 2Mbps (0% idle time in preambles mode), 200pF load on TXUP and TXUN, TXL not active, not in acquisition mode, BALSWEEN, CTSTEN = 0000h		170	300	μA
HV Current, ADC Acquisition Mode	I_{HVMEAS}	ADC-only acquisition, all cells and auxiliary channels enabled, $V_{HV} = V_{DCIN} + 5.5V$	0.9	1.1	1.3	mA
HV Current, Comparator (COMP) Scan Mode	I_{HVCOMP}	COMP-only acquisition, all cells and auxiliary channels enabled, $V_{HV} = V_{DCIN} + 5.5V$		1.8		mA
Incremental HV Current, Cell-Balancing Mode	I_{HVBAL}	$V_{HV} = V_{DCIN} + 5.5V$, n balancing switches enabled	(n + 1) x 5	(n + 1) x 15.5	(n + 1) x 26	μA
CELL VOLTAGE INPUTS (Cn, VBLK)						
Differential Input Range (Note 7)	V_{CELLn}	Unipolar mode	0		5	V
		Bipolar mode	-2.5		+2.5	
Common-Mode Input Range	V_{CnCM}	Not connected to SWn inputs	0		65	V
Input Leakage Current	I_{LKG_Cn}	Not in acquisition mode, $V_{Cn} = 65V$	-100	± 10	+100	nA
VBLK Input Resistance	R_{VBLK}	$V_{VBLK} = V_{DCIN} = 57.6V$	4.5	10	20	M Ω
HVMUX Switch Resistance	R_{HVMUX}	CTSTDAC[3:0] = Fh	1.7	3.3	5	k Ω

Electrical Characteristics (continued)

($V_{DCIN} = +56V$, $T_A = T_{MIN}$ to T_{MAX} unless otherwise noted, where $T_{MIN} = -40^{\circ}C$ and $T_{MAX} = +125^{\circ}C$. Typical values are at $T_A = +25^{\circ}C$. Operation is with the recommended application circuit.) (Note 5)

PARAMETER	SYMBOL	CONDITIONS	MIN	TYP	MAX	UNITS
CELL-BALANCING INPUTS (SWn)						
Leakage Current	I_{LKG_SW}	$V_{SW0} = 0V$, $V_{SWn} = 5V$, $V_{SWn-1} = 0V$	-1		+1	μA
Resistance, SWn to SWn-1	R_{SW}	BALSWEN[n-1] = 1, $I_{SWn} = 100mA$	0.5	1.25	2.25	Ω
Resistance, SWn to SWn-1 (Note 8)	R_{SW}	BALSWEN[n-1] = 1, $I_{SWn} = 300mA$		1.3		
Maximum Allowed Balancing Current (Note 9)	I_{BAL_MAX}	$T_J = +125^{\circ}C$, CBMEASEN= 0x00, FLXPCKEN=0, all even or all odd channels enabled		650		mA
AUXILIARY INPUTS (AUXIn)						
Input Voltage Range	V_{AUXIN}	$V_{ADCREf} = V_{THRM}$ or V_{REF} based on AUXREFSEL	0		V_{ADCREf}	V
Input Leakage Current	I_{LKG_AUX}	Not in acquisition mode, $V_{AUXIn} = 1.65V$	-400	10	+400	nA
THRM OUTPUT						
Switch Resistance, V_{AA} to THRM	R_{THRM}			25	70	Ω
Leakage Current	I_{LKG_THRM}	$V_{THRM} = 3.3V$	-1		+1	μA
MEASUREMENT ACCURACY						
ADC Measurement Error, HVMUX Inputs (Note 10)	$V_{CELLnERR}$	Unipolar mode, $V_{CELLn} = 3.6V$, SCANMODE=0x0, 0x1		± 0.45		mV
		Bipolar mode, $V_{CELLn} = 1.1V$, SCANMODE=0x0, 0x1		± 0.45		
ADC Measurement Error, HVMUX Inputs (Note 10)	$V_{CELLnERR}$	Unipolar mode, $0.2V \leq V_{CELLn} \leq 4.8V$, SCANMODE=0x0, 0x1	-4.5		+4.5	mV
		Bipolar mode, $-2.3V \leq V_{CELLn} \leq 2.3V$, SCANMODE=0x0, 0x1	-4.5		+4.5	
ADC Measurement Error, HVMUX Inputs (Note 10)	$V_{CELLnERR}$	Unipolar mode, $1.9V \leq V_{CELLn} \leq 4.2V$, SCANMODE=0x0, 0x1, $5^{\circ}C < Temp < 40^{\circ}C$	-2		+2	mV
ADC Measurement Error, ALTMUX Inputs (Note 10)	V_{SWnERR}	Unipolar mode, $V_{CELLn} = 3.6V$, SCANMODE=0x0, 0x1		± 0.45		mV
		Bipolar mode, $V_{CELLn} = 1.1V$, SCANMODE=0x0, 0x1		± 0.45		
		Unipolar mode, $0.2V \leq V_{CELLn} \leq 4.8V$, SCANMODE=0x0, 0x1	-4.5		+4.5	
		Bipolar mode, $-2.3V \leq V_{CELLn} \leq 2.3V$, SCANMODE=0x0, 0x1	-4.5		+4.5	

Electrical Characteristics (continued)

($V_{DCIN} = +56V$, $T_A = T_{MIN}$ to T_{MAX} unless otherwise noted, where $T_{MIN} = -40^{\circ}C$ and $T_{MAX} = +125^{\circ}C$. Typical values are at $T_A = +25^{\circ}C$. Operation is with the recommended application circuit.) (Note 5)

PARAMETER	SYMBOL	CONDITIONS	MIN	TYP	MAX	UNITS
ADC Measurement Error, VBLK Input (Note 11)	V_{BLKERR}	$9V \leq V_{BLK} \leq 65V$, $V_{DCIN} = 65V$, SCANMODE=0x0, 0x1	-110		+110	mV
		$9V \leq V_{BLK} \leq 58.8V$, $V_{DCIN} = 58.8V$, SCANMODE=0x0, 0x1	-100		+100	
ADC Measurement Error, AUXIN Inputs (Note 11)	$V_{OS_AUX_RATIO}$	AUXREF[n] = 0b, SCANMODE = 0x0, 0x1	-3.5		+3.5	mV
ADC Measurement Error, AUXIN Inputs (Note 11)	$V_{OS_AUX_ABS}$	AUXREF[n]=1b, SCANMODE = 0x0, 0x1	-2.5		+2.5	mV
Total Measurement Error, Die Temperature (Note 8)	T_{DIE_ERR}	$T_J = -40^{\circ}C$ to $+125^{\circ}C$, OVSAMPL[2:0] = 000b	-5	0	+5	$^{\circ}C$
Channel Noise (Note 8)	$V_{CELLNOISE}$	OVSAMPL[2:0] = 0x3h		250		μV_{RMS}
Differential Nonlinearity (Any Conversion)	DNL			± 1.0		LSbs
ADC Resolution			12			bits
Level-Shifting Amplifier Offset (Note 12)	V_{OS_LSAMP}	DIAGSEL[2:0] = 011b	-200	-10	+200	mV
COMPARATOR						
Comparator Accuracy	V_{OS_COMP}	$0.2V \leq V_{CELLn} \leq 4.8V$	-20		+20	mV
SHDNL INPUT AND CHARGE PUMP						
Input Low Voltage	V_{IL_SHDNL}				0.6	V
Input High Voltage	V_{IH_SHDNL}		1.8			V
Regulated Voltage	$V_{SHDNLIMIT}$	$V_{DCIN} \geq 12V$	8	9.5	12	V
		$V_{DCIN} = 9V$		6.7		
Pulldown Resistance	$R_{FORCEPOR}$	FORCEPOR = 1	2.5	4.7	8	k Ω
Input Leakage Current	I_{LKG_SHDNL}	$V_{SHDNL} = 3.3V$			1	μA
		$V_{SHDNL} = 65V$			40	
Charge-Pump Current, UARTL/UARTU (Note 13)	I_{SHDNL}	$V_{SHDNL} < V_{SHDNLIMIT}$, baud rate = 2Mbps	15	117	350	μA
UARTSEL						
UARTSEL Input Low Voltage	$V_{IL_UARTSEL}$				$0.3 \times V_{AA}$	V
UARTSEL Input High Voltage	$V_{IH_UARTSEL}$		$0.7 \times V_{AA}$			V
UARTSEL Pullup Resistance	$R_{UARTSEL}$			100		k Ω
GENERAL-PURPOSE I/O (GPIO_n)						
Input Low Voltage	V_{IL_GPIO}				$0.3 \times V_{DDL2}$	V
Input High Voltage	V_{IH_GPIO}		$0.7 \times V_{DDL2}$			V

Electrical Characteristics (continued)

($V_{DCIN} = +56V$, $T_A = T_{MIN}$ to T_{MAX} unless otherwise noted, where $T_{MIN} = -40^{\circ}C$ and $T_{MAX} = +125^{\circ}C$. Typical values are at $T_A = +25^{\circ}C$. Operation is with the recommended application circuit.) (Note 5)

PARAMETER	SYMBOL	CONDITIONS	MIN	TYP	MAX	UNITS
Pulldown Resistance	R_{GPIO}	AUXINn/GPIOn configured as GPIO input	0.5	2	7.5	$M\Omega$
Output Low Voltage	V_{OL_GPIO}	$I_{SINK} = 3mA$			0.4	V
Output High Voltage	V_{OH_GPIO}	$I_{SOURCE} = 3mA$	V_{DDL2} - 0.4			V
ALERTIN						
ALERTIN High-Comparator Threshold	V_{CH}		$-V_{AA}/2$ - 0.4	$-V_{AA}/2$	$-V_{AA}/2 + 0.4$	V
ALERTIN Zero-Crossing Comparator Threshold	V_{ZC}		-0.4	0	+0.4	V
ALERTIN Low-Comparator Threshold	V_{CL}		$V_{AA}/2$ - 0.4	$V_{AA}/2$	$V_{AA}/2 + 0.4$	V
ALERTIN Comparator Hysteresis	$V_{HYS_ALERTIN}$			75		mV
ALERTIN Common-Mode Voltage Bias	V_{CM}			$V_{AA}/3$		V
Leakage Current	$I_{LKG_ALERTIN}$	$V_{ALERTIN} = 1.5V$		± 1.0		μA
Input Capacitance	$C_{ALERTIN}$			2		pF
Bit Period (Note 14)	t_{BIT}			8		$1/f_{OSC_16M}$
ALERTIN Fall Time (Notes 8, 15)	$t_{ALERTIN_FALL}$				0.5	t_{BIT}
ALERTIN Rise Time (Notes 8, 15)	$t_{ALERTIN_RISE}$				0.5	t_{BIT}
ALERTIN Qualification Time	$t_{ALERTIN_QUAL}$			25		μs
Propagation Delay (ALERTIN Port to ALERTOUT Port)	t_{ALERT_PROP}			2.5	3	t_{BIT}
Startup Time from SHNDL High and $V_{AA} = 0V$ to ALERTIN Valid	$t_{ALERTIN_STARTUP}$			1		ms
ALERTOUT						
Output Low Voltage	$V_{OL_ALERTOUT}$	$I_{SINK} = 20mA$			0.4	V
Output High Voltage	$V_{OH_ALERTOUT}$	$I_{SOURCE} = 20mA$	V_{DDL2} - 0.4			V
Leakage Current	$I_{LKG_ALERTOUT}$	$V_{ALERTOUT} = 1.5V$	-1		+1	μA
REGULATOR						
Output Voltage	V_{AA}	$0 \leq I_{AA} < 20mA$	3.2	3.3	3.4	V
Short-Circuit Current	I_{AASC}	V_{AA} shorted to AGND	30			mA

Electrical Characteristics (continued)

($V_{DCIN} = +56V$, $T_A = T_{MIN}$ to T_{MAX} unless otherwise noted, where $T_{MIN} = -40^{\circ}C$ and $T_{MAX} = +125^{\circ}C$. Typical values are at $T_A = +25^{\circ}C$. Operation is with the recommended application circuit.) (Note 5)

PARAMETER	SYMBOL	CONDITIONS	MIN	TYP	MAX	UNITS
POR Threshold	$V_{PORFALL}$	V_{AA} falling	2.85	2.95	3.02	V
	$V_{PORRISE}$	V_{AA} rising		3	3.1	
	V_{PORHYS}			40		mV
Thermal-Shutdown Temperature (Note 8)	T_{SHDN}	Temperature rising		145		$^{\circ}C$
Thermal-Shutdown Hysteresis (Note 8)	T_{HYS}			15		$^{\circ}C$
HV CHARGE PUMP						
Output Voltage ($V_{HV} - V_{DCIN}$)	$V_{HV-DCIN}$	$9V \leq V_{DCIN} \leq 12V$, $I_{LOAD} = 1.5mA$	5.9	6.2	6.5	V
		$12V \leq V_{DCIN} \leq 65V$, $I_{LOAD} = 3mA$	5.9	6.2	6.5	
Output Voltage ($V_{HV} - V_{TOPCELL}$)	$V_{HV-DCIN_FLEX}$	$14V \leq V_{DCIN} \leq 65V$, $I_{LOAD} = 3mA$, FLXPACKEN1/2	10.2		11	V
Charge-Pump Efficiency (Note 16)	Eff_{HVCP}	$V_{DCIN} = 57.6V$		38		%
OSCILLATORS						
32kHz Oscillator Frequency	f_{OSC_32K}		32.11	32.768	33.42	kHz
16MHz Oscillator Frequency	f_{OSC_16M}		15.68	16	16.32	MHz
DIAGNOSTIC TEST SOURCES						
Cell Test Source Current	I_{TSTCn}	CTSTDAC[3:0] = 9h, $V_{C0} < V_{AA} - 1.4V$, $V_{AA} = 3.3V$	50	62.5	75	μA
		CTSTDAC[3:0] = 6h, $V_{C0} < V_{AA} - 1.4V$, $V_{AA} = 3.3V$	36	45	54	
		CTSTDAC[3:0] = 6h, $V_{C1-C14} > V_{AGND} + 1.4V$	-54	-45	-36	
		CTSTDAC[3:0] = 9Fh, $V_{C1-C14} > V_{AGND} + 1.4V$	-75	-62.5	-50	
HVMUX Test Source Current	$I_{TSTHVMUX}$	CTSTDAC[3:0] = 9h, $V_{Cn} < V_{HV} - 1.4V$, $V_{HV} = 53.5V$	25	31.25	37.5	μA
		CTSTDAC[3:0] = 6h, $V_{Cn} < V_{HV} - 1.4V$, $V_{HV} = 53.5V$	18	22.5	27	
AUXIN Test Source Current	$I_{TSTAUXIN}$	CTSTDAC[3:0] = 9h, $V_{AUXINn} < V_{DDL2} - 1.4V$, $V_{DDL2} = 3.3V$	50	62.5	75	μA
		CTSTDAC[3:0] = 6h, $V_{AUXINn} < V_{DDL2} - 1.4V$, $V_{DDL2} = 3.3V$	36	45	54	
		CTSTDAC[3:0] = 6h, $V_{AUXINn} > V_{AGND} + 1.4V$	-54	-45	-36	
		CTSTDAC[3:0] = 9h, $V_{AUXINn} > V_{AGND} + 1.4V$	-75	-62.5	-50	

Electrical Characteristics (continued)

($V_{DCIN} = +56V$, $T_A = T_{MIN}$ to T_{MAX} unless otherwise noted, where $T_{MIN} = -40^{\circ}C$ and $T_{MAX} = +125^{\circ}C$. Typical values are at $T_A = +25^{\circ}C$. Operation is with the recommended application circuit.) (Note 5)

PARAMETER	SYMBOL	CONDITIONS	MIN	TYP	MAX	UNITS
DIAGNOSTIC REFERENCES						
ALTREF Voltage (Note 12)	V_{ALTREF}	DIAGSEL[2:0]=001b	1.23	1.242	1.254	V
ALTREF Temperature Coefficient ($\Delta V_{ALTREF}/\Delta T$) (Note 8)	A_{ALTREF}			±25		ppm/°C
PTAT Output Voltage (Note 8)	V_{PTAT}	$T_J = +120^{\circ}C$		1.2		V
PTAT Temperature Coefficient ($\Delta V_{PTAT}/\Delta T$) (Note 8)	A_{V_PTAT}			3.02		mV/°C
PTAT Temperature Offset (Note 8)	T_{OS_PTAT}			-8.3		°C
ALERTS						
ALRTVDDLn Threshold	V_{VDDL_OC}	$V_{AA} = 3.3V$	3	3.15	3.25	V
ALRTGNDLn Threshold	V_{GNDL_OC}	AGND = 0V	0.05	0.15	0.3	V
ALRTHVUV Threshold	V_{HVUV}	$V_{HV} - V_{DCIN}$ falling, FLXPACK-EN1/2=0	4.5	4.75	5.0	V
		$V_{HV} - V_{DCIN}$ falling, FLXPACK-EN1/2=1	8.5	9.25	9.5	
ALRTHVOV Threshold	V_{HVOV}	$V_{HV} - V_{DCIN}$ rising	14	16	20	V
ALRTHVHDRM Threshold	V_{HVHDRM}	ALRTHVHDRM=0	4.7			V
ALRTTEMP Threshold (Note 8)	$T_{ALRTTEMP}$		115	120	125	°C
ALRTTEMP Hysteresis (Note 8)	$T_{ALRTTEMPHYS}$			2		°C
UART OUTPUTS (TXLP, TXLN, TXUP, TXUN)						
Output Low Voltage	V_{OL}	$I_{SINK} = 20mA$			0.4	V
Output High Voltage (TXLP, TXLN)	V_{OH}	$I_{SOURCE} = 20mA$		$V_{DDL2} - 0.4$		V
Output High Voltage (TXUP, TXUN)	V_{OH}	$I_{SOURCE} = 20mA$		$V_{DDL3} - 0.4$		V
Leakage Current	I_{LKG_TX}	$V_{TX} = 1.5V$	-1		+1	μA
UART INPUTS (RXLP, RXLN, RXUP, RXUN)						
Input Voltage Range	V_{RX}		-25		+25	V
Receiver High Comparator Threshold (Note 17)	V_{CH}		$V_{AA}/2 - 0.4$	$V_{AA}/2$	$V_{AA}/2 + 0.4$	V
Receiver Zero-Crossing Comparator Threshold (Note 17)	V_{ZC}		-0.4	0	+0.4	V
Receiver Low Comparator Threshold (Note 17)	V_{CL}		$-V_{AA}/2 - 0.4$	$-V_{AA}/2$	$-V_{AA}/2 + 0.4$	V

Electrical Characteristics (continued)

($V_{DCIN} = +56V$, $T_A = T_{MIN}$ to T_{MAX} unless otherwise noted, where $T_{MIN} = -40^{\circ}C$ and $T_{MAX} = +125^{\circ}C$. Typical values are at $T_A = +25^{\circ}C$. Operation is with the recommended application circuit.) (Note 5)

PARAMETER	SYMBOL	CONDITIONS	MIN	TYP	MAX	UNITS
Receiver Comparator Hysteresis (Note 17)	V_{HYS_RX}			75		mV
Receiver Common-Mode Voltage Bias (Note 17)	V_{CM}			$V_{AA}/3$		V
Leakage Current	I_{LKG_RX}	$V_{RX} = 1.5V$		± 1.0		μA
Input Capacitance (RXLP, RXLN)	C_{RXL}			4		pF
Input Capacitance (RXUP, RXUN)	C_{RXU}			4		pF
UART TIMING						
Bit Period (Note 14)	t_{BIT}	Baud rate = 2Mbps		8		1/ f_{OSC_16M}
		Baud rate = 1Mbps		16		
		Baud rate = 0.5Mbps		32		
Rx Idle to Start Setup Time (Note 8)	t_{RXSTSU}		0		1	t_{BIT}
STOP Hold Time to Idle (Note 8)	t_{SPHD}				0.5	t_{BIT}
Rx Minimum Idle Time (Stop Bit to Start Bit) (Note 8)	$t_{RXIDLESPST}$		1			t_{BIT}
Rx Fall Time (Notes 8, 15)	t_{FALL}				0.5	t_{BIT}
Rx Rise Time (Notes 8, 15)	t_{RISE}				0.5	t_{BIT}
Propagation Delay (RX Port to Tx Port)	t_{PROP}			2.5	3	t_{BIT}
Startup Time from SHNDL High and $V_{AA} = 0V$ to RXUP/RXUN Valid	$t_{STARTUP}$			1		ms
SERIAL PERIPHERAL INTERFACE (SPI)						
SPI ELECTRICAL CHARACTERISTICS: POWER REQUIREMENTS						
I/O Supply Voltage	V_{DDIO}	$V_{DDIO} = V_{DDL2} = V_{DDL3}$ for SPI applications	V_{AA}	5	5.5	V
Static I/O Supply Current (Note SPI-1)	I_{DDIO}	Static inputs, all outputs unloaded			± 25	μA
SPI ELECTRICAL CHARACTERISTICS: DIGITAL INPUT CHARACTERISTICS (SCLK, SDIN, CSB)						
Input High Voltage	V_{IH}	$3.0V < V_{DDIO} < 5.5V$		$0.7 \times V_{DDIO}$		V
Input Low Voltage	V_{IL}	$3.0V < V_{DDIO} < 5.5V$		$0.3 \times V_{DDIO}$		V
Input Leakage Current (Note SPI-2)	I_{IN}	$V_{IN} = 0V$ or V_{DDIO}			± 1	μA
Internal Safety Impedance (Note SPI-3, SPI-4)	R_{PD}	SDI, SCLK pulldown to GND	40	100	160	k Ω
	R_{PU}	CSB pulup to V_{DDIO}	40	100	160	

Electrical Characteristics (continued)

($V_{DCIN} = +56V$, $T_A = T_{MIN}$ to T_{MAX} unless otherwise noted, where $T_{MIN} = -40^{\circ}C$ and $T_{MAX} = +125^{\circ}C$. Typical values are at $T_A = +25^{\circ}C$. Operation is with the recommended application circuit.) (Note 5)

PARAMETER	SYMBOL	CONDITIONS	MIN	TYP	MAX	UNITS
Input Capacitance	C_{IN}			20		pF
Hysteresis Voltage	V_H			0.15		V
SPI ELECTRICAL CHARACTERISTICS: DIGITAL OUTPUT CHARACTERISTICS (SDO)						
Output High Voltage	V_{OH}	$V_{DDIO} > 3.0V$, $I_{SOURCE} = 5mA$	$V_{DDIO} - 0.4$			V
Output Low Voltage	V_{OL}	$V_{DDIO} > 3.0V$, $I_{SINK} = 5mA$			0.4	V
Output Short-Circuit Current	I_{OSS}	I_{SOURCE}	600			mA
		I_{SINK}	220			
Output Three-State Leakage	I_{OZ}				± 1	μA
Output Three-State Capacitance	C_{OZ}			20		pF
SPI TIMING CHARACTERISTICS						
SCLK Frequency (Note SPI-5)	f_{SCLK}		0.1		10	MHz
SCLK Period	t_{CP}		100		10,000	ns
SCLK Pulse Width High	t_{CH}		40			ns
SCLK Pulse Width Low	t_{CL}		40			ns
CSB Fall to SCLK Rise Setup Time	t_{CSS0}	Applies to 1st SCLK rising edge	40			ns
CSB Fall to SCLK Rise Hold Time	t_{CSH0}	Applies to inactive rising edge preceding 1st rising edge	25			ns
SCLK Rise to CSB Rise Hold Time	t_{CSH1}	Applies to 32nd rising edge	25			ns
CSB Rise to SCLK Rise	t_{CSA}	Applies to 32nd rising edge, guarantees aborted (unqualified) sequence	15			ns
	t_{CSQ}	Applies to 33rd rising edge, guarantees qualified sequence	15			
CSB Pulse Width High	t_{CSPW}		400			ns
CSB Pulse Width High After SWPOR	t_{CSPWSP}	Applies after an accepted/executed SWPOR command.	100			μs
SDI to SCLK Rise Setup Time	t_{DS}		10			ns
SDI to SCLK Rise Hold Time	t_{DH}		10			ns
SCLK Fall to SDO Transition	t_{DOT}	$C_{LOAD} = 20pF$			30	ns
SCLK Fall to SDO Hold	t_{DOH}	$C_{LOAD} = 0pF$	2			ns
CSB Fall to SDO Transition	t_{DOE}	$C_{LOAD} = 20pF$			30	ns
CSB Rise to SDO Hi-Z	t_{DOZ}	Output disable time			25	ns
Time Out Period (Note SPI-6)	t_{TO}	Transactions exceeding this duration be rejected			360	μs

Electrical Characteristics (continued)

($V_{DCIN} = +56V$, $T_A = T_{MIN}$ to T_{MAX} unless otherwise noted, where $T_{MIN} = -40^{\circ}C$ and $T_{MAX} = +125^{\circ}C$. Typical values are at $T_A = +25^{\circ}C$. Operation is with the recommended application circuit.) (Note 5)

- Note 5:** Unless otherwise noted, limits are 100% production tested at $T_A = +25^{\circ}C$. Limits over the operating temperature range and relevant supply voltage range are guaranteed by design and characterization.
- Note 6:** Acquisition mode (ADC conversions) is entered when the SCAN bit is set and ends when SCANDONE is set. With the typical acquisition duty cycle very low, the average current I_{DCIN} is much less than I_{DCMEAS} . Total supply current during communication $I_{DCIN} = I_{DCCOMM} + I_{DCSTBY}$.
- Note 7:** Measurement-accuracy range is guaranteed from $V_{CELLn_min} + 0.2V$ and $V_{CELLn_max} - 0.2V$.
- Note 8:** Guaranteed by design and not production tested.
- Note 9:** Not production tested. See the [Cell-Balancing Current](#) section for details on the maximum allowed balancing current. Duty cycle is calculated for a 10-year device lifetime.
- Note 10:** $V_{CELLn} = V_{Cn} - V_{Cn-1}$, $V_{CELLn} = V_{CELLn-1}$, and $V_{DCIN} = 14 \times |V_{CELLn}|$ ($V_{DCIN} = 9V$ minimum). Accuracy measurement represents initial total measurement error with the input noise oversampled below 1LSB and over the temperature range of $-20^{\circ}C$ to $+125^{\circ}C$. For specific measurement criteria, contact Maxim.
- Note 11:** Accuracy measurement represents initial total measurement error with the input noise oversampled below 1LSB.
- Note 12:** As measured during specified diagnostic mode.
- Note 13:** I_{SHDNL} measured with $V_{SHDNL} = 0.3V$, STOP characters, zero idle time, $V_{RX_PEAK} = 3.3V$.
- Note 14:** In daisy-chain applications, the bit time of the second stop bit may be less than specified to account for clock-rate variation and sampling error between devices.
- Note 15:** Fall time measured 90% to 10%; rise time measured 10% to 90%.
- Note 16:** Charge-pump efficiency = $\Delta I_{LOAD} / \Delta I_{SUPPLY}$, where I_{LOAD} is applied from HV to AGND; $\Delta I_{LOAD} = 5mA$, and $\Delta I_{SUPPLY} = I_{DCIN}$ (for $I_{LOAD} = 5mA$) - I_{DCIN} (for $I_{LOAD} = 0$).
- Note 17:** Differential signal ($V_{RXP} - V_{RXN}$) where V_{RXP} and V_{RXN} do not exceed a common-mode voltage range of $\pm 25V$.
- Note SPI-1:** Static logic inputs with $V_{IL} = GNDL2/GNDL3$ and $V_{IH} = V_{DDIO}$ (Note 1). CSB = V_{IH} (if pullup active).
- Note SPI-2:** No internal safety pullup/pulldown impedances active, input buffers only.
- Note SPI-3:** Internal safety pullup/pulldown impedances available with enable function.
- Note SPI-4:** If pulup is supported, note CSB connection and diode to V_{DDL2} ; this diode is present regardless of enable mode.
- Note SPI-5:** Applications must afford time for the device to drive data on the SDO bus and meet the μC setup time prior to the μC latching in the result on the following SCLK rising edge. In practice, this can be determined by loading and μC characteristics, and the relevant t_{DOT}/t_{DOE} .
- Note SPI-6:** Minimum specification is $32 \times T_{CP_MAX}$ and must account for the fastest possible frequency of the internal 16MHz oscillator (proposed numbers assume 5% variation over T_{PV}).

Typical Operating Characteristics

($V_{DCIN} = 56V$, $V_{AA} = 3.3V$, $T_A = +25^\circ C$, unless otherwise noted.)

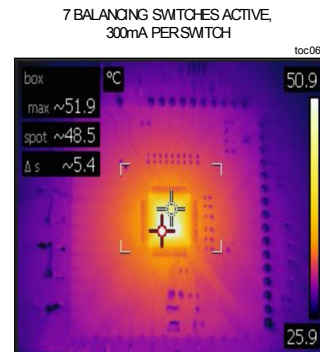
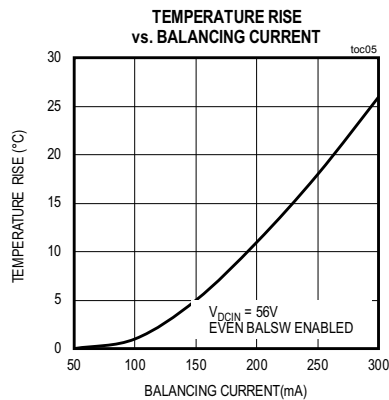
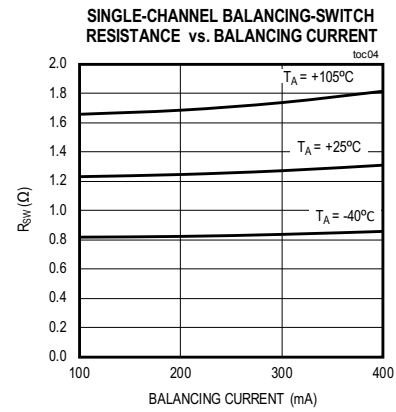
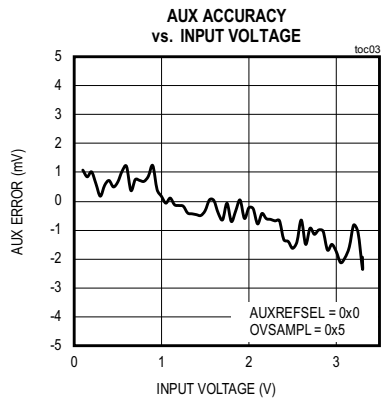
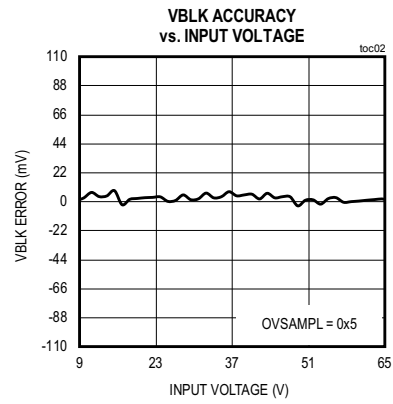
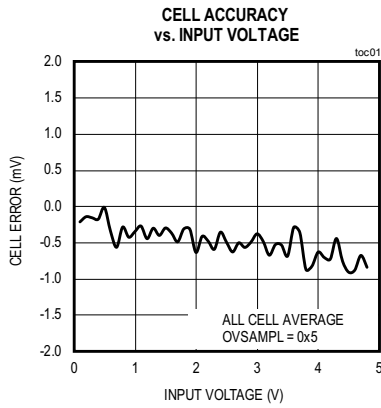

Typical Operating Characteristics (continued)

($V_{DCIN} = 56V$, $V_{AA} = 3.3V$, $T_A = +25^\circ C$, unless otherwise noted.)

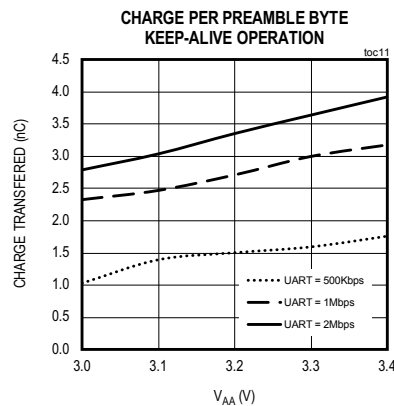
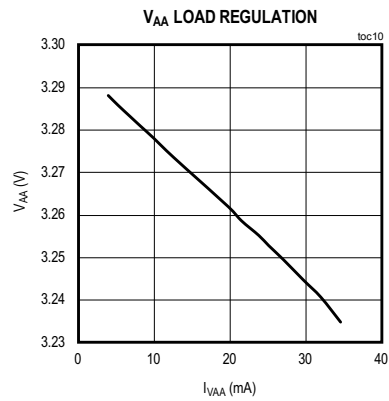
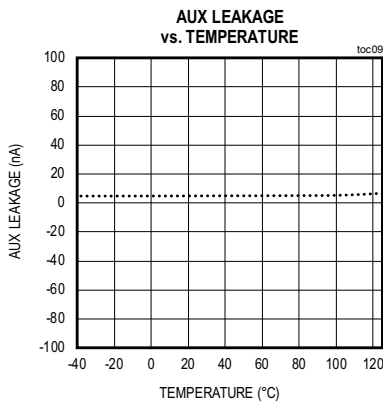
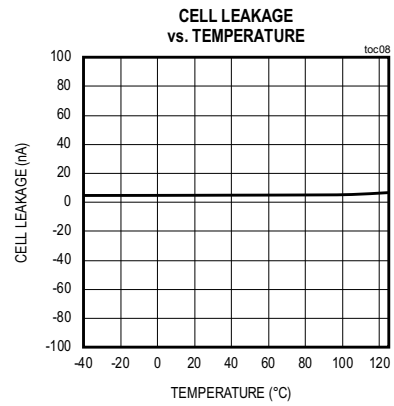
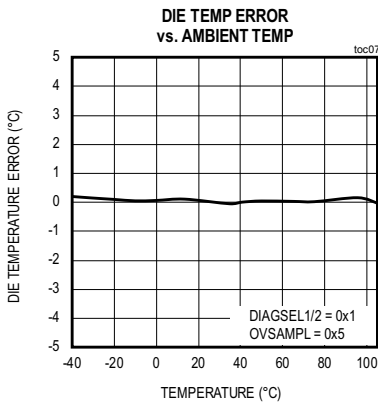

Pin Configuration

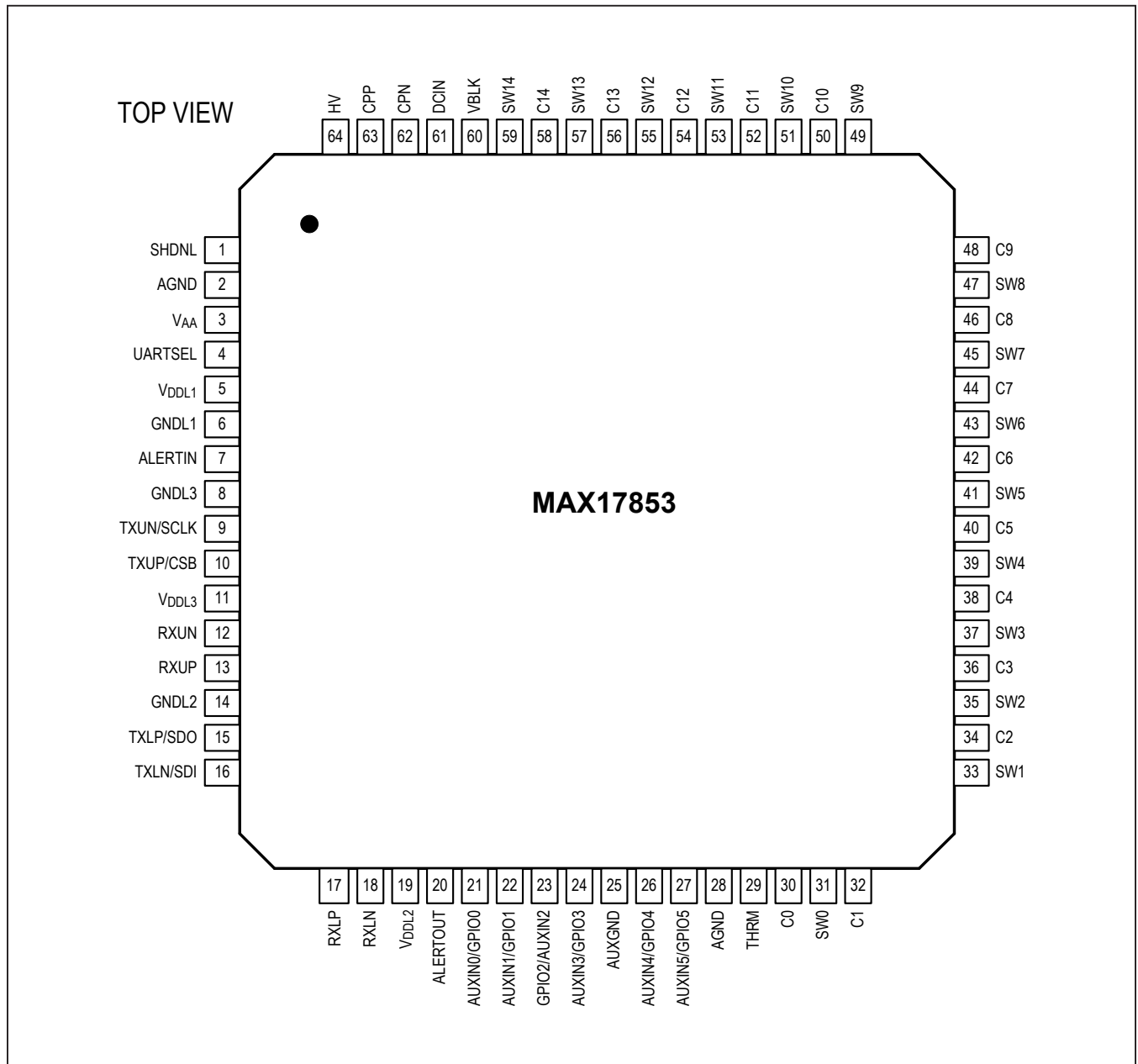

Pin Description

PIN	NAME	FUNCTION	REF SUPPLY	TYPE
1	SHDNL	Shutdown Active-Low Input. Drive > 1.8V to enable operation and drive < 0.6V to reset device and place in shutdown mode. +72V tolerant. UART Operation: If not driven externally, this input can be controlled solely through UART communication and software control. Bypass with a 1nF capacitor to AGND. For single-ended UART, SHDNL must be driven externally. SPI Operation: SHDNL must be driven external	AGND	Input
2, 28	AGND	Analog Ground. Connect to negative terminal of cell 1 and ground plane.	DCIN	Ground
3	V _{AA}	V _{AA} Output Used to Supply V _{DDL1} , and optionally V _{DDL2} and V _{DDL3} . Bypass with a 1μF capacitor to AGND.	AGND	Power
4	UARTSEL	UART/SPI Interface Selection. Connect to V _{AA} for UART interface, pull to AGND for SPI interface.	V _{DDL1}	Input
5	V _{DDL1}	3.3V Digital Supply. Connect externally to V _{AA} and bypass with 0.47μF capacitor to GNDL1.	GNDL1	Power
6	GNDL1	Digital Ground. Connect to ground plane.	V _{DDL1}	Ground
7	ALERTIN	Fault Alert Input. Connect to upper daisy-chain device.	V _{AA}	Input
8	GNDL3	Ground for Upper-Port Transmitter. Connect to ground plane.	V _{DDL3}	Ground
9	TXUN/SCLK	Negative Output for Upper-UART Transmitter or SCLK Input for SPI Interface Depending on the UARTSEL Selection. Driven between V _{DDL3} and GNDL3.	V _{DDL3}	Output/ Input
10	TXUP/CSB	Positive Output for Upper-UART Transmitter or CSB Input for SPI Interface Depending on UARTSEL Selection. Driven between V _{DDL3} and GNDL3.	V _{DDL3}	Output/ Input
11	V _{DDL3}	Supply for Upper-UART Transceiver, SPI Multifunctional Pins, and ALERT Pins. Connect externally to V _{DDL2} and bypass with 0.47μF capacitor to GNDL3. V _{DDL3} must be ≥ V _{AA}	GNDL3	Power
12	RXUN	Negative Input for Upper-UART Port Receiver. If not used, pins can be unconnected or connected to GNDL3. Tolerates ±30V.	V _{AA}	Input
13	RXUP	Positive Input for Upper-UART Port Receiver. If not used, pins can be left unconnected or connected to GNDL3. Tolerates ±30V. If configured for single-ended UART, connect to GNDL3.	V _{AA}	Input
14	GNDL2	Ground for Lower-Port Transmitter. Connect to ground plane.	V _{DDL2}	Ground
15	TXLP/SDO	Positive Output for Lower-UART Transmitter or SDO Output (MISO) for SPI Interface Depending on UARTSEL Selection. Driven between V _{DDL2} and GNDL2.	V _{DDL2}	Output
16	TXLN/SDI	Negative Output for Lower-UART Transmitter or SDI (MOSI) Input for SPI Interface Depending on UARTSEL Selection. Driven between V _{DDL2} and GNDL2.	V _{DDL2}	Output/ Input
17	RXLP	Positive Input for Lower-UART Port Receiver. If not used pins can be left unconnected or connected to GNDL3. Tolerates ±30V. If configured for single-ended UART, connect to GNDL3.	V _{AA}	Input
18	RXLN	Negative Input for Lower-UART Port Receiver. If not used, pins can be unconnected or connected to GNDL2. Tolerates ±30V.	V _{AA}	Input
19	V _{DDL2}	Supply for Lower-UART Transceiver, SPI Multifunctional Pins, and ALERT Pins. Connect externally to V _{DDL3} and bypass with 0.47μF capacitor to GNDL2. V _{DDL2} must be ≥ V _{AA} .	GNDL2	Power
20	ALERTOUT	Alert Output Interface. Configured using SPIDRVINT bit as daisy-chained CMOS output (connected to ALERTIN), or open-drain output (connected to external 10kΩ pullup to V _{DDL2} , V _{DDL3}).	V _{DDL2}	Output

Pin Description (continued)

PIN	NAME	FUNCTION	REF SUPPLY	TYPE
21	AUXIN0/ GPIO0	Configurable Between Auxiliary Input or General-Purpose I/O. When configured as a ratiometric auxiliary input for temperature measurement, connect to a voltage-divider consisting of a 10k Ω pullup to THRM and a 10k Ω NTC thermistor to AGND. If not used, connect to the pullup only. When configured to GPIO, it is driven between V_{DDL2} and GNDL2. 2M Ω internal pulldown when the pin is configured as an input.	V_{DDL2}	Input/ Output
22	AUXIN1/ GPIO1	Configurable Between Auxiliary Input or General-Purpose I/O. When configured as a ratiometric auxiliary input for temperature measurement, connect to a voltage-divider consisting of a 10k Ω pullup to THRM and a 10k Ω NTC thermistor to AGND. If not used, connect to the pullup only. When configured to GPIO, it is driven between V_{DDL2} and GNDL2. 2M Ω internal pulldown when the pin is configured as an input.	V_{DDL2}	Input/ Output
23	AUXIN2/ GPIO2	Configurable Between Auxiliary Input or General-Purpose I/O. When configured as a ratiometric auxiliary input for temperature measurement, connect to a voltage-divider consisting of a 10k Ω pullup to THRM and a 10k Ω NTC thermistor to AGND. If not used, connect to the pullup only. When configured to GPIO, it is driven between V_{DDL2} and GNDL2. 2M Ω internal pulldown when the pin is configured as an input.	V_{DDL2}	Input/ Output
24	AUXIN3/ GPIO3	Configurable Between Auxiliary Input or General-Purpose I/O. When configured as a ratiometric auxiliary input for temperature measurement, connect to a voltage-divider consisting of a 10k Ω pullup to THRM and a 10k Ω NTC thermistor to AGND. If not used, connect to the pullup only. When configured to GPIO, it is driven between V_{DDL2} and GNDL2. 2M Ω internal pulldown when the pin is configured as input.	V_{DDL2}	Input/ Output
25	AUXGND	Connect to AGND ground plane	V_{AA}	Power
26	AUXIN4/ GPIO4	Configurable Between Auxiliary Input or General-Purpose I/O. When configured as a ratiometric auxiliary input for temperature measurement, connect to a voltage-divider consisting of a 10k Ω pullup to THRM and a 10k Ω NTC thermistor to AGND. If not used, connect to the pullup only. When configured to GPIO, it is driven between V_{DDL2} and GNDL2. 2M Ω internal pulldown when the pin is configured as input.	V_{DDL2}	Input/ Output
27	AUXIN5/ GPIO5	Configurable Between Auxiliary Input or General-Purpose I/O. When configured as a ratiometric auxiliary input for temperature measurement, connect to a voltage-divider consisting of a 10k Ω pullup to THRM and a 10k Ω NTC thermistor to AGND. If not used, connect to the pullup only. When configured to GPIO, it is driven between V_{DDL2} and GNDL2. 2M Ω internal pulldown when the pin is configured as input.	V_{DDL2}	Input/ Output
29	THRM	Switched Output Connected Internally to V_{AA} . THRM is used to drive the external NTC voltage-divider for the auxiliary inputs. The output is enabled only during measurements or as configured by THRMODE[1:0]. This output can source up to 2mA.	AUXGND	Power
30	C0	Voltage Input for Cell 1 Negative. Connect to AGND.	—	Input

Pin Description (continued)

PIN	NAME	FUNCTION	REF SUPPLY	TYPE
31	SW0	Balance Input for Cell 1 Negative	—	Input
32	C1	Voltage Input for Cell 1 Positive (Cell 2 Negative)	—	Input
33	SW1	Balance Input for Cell 1 Positive (Cell 2 Negative)	—	Input
34	C2	Voltage Input for Cell 2 Positive (Cell 3 Negative)	—	Input
35	SW2	Balance Input for Cell 2 Positive (Cell 3 Negative)	—	Input
36	C3	Voltage Input for Cell 3 Positive (Cell 4 Negative)	—	Input
37	SW3	Balance Input for Cell 3 Positive (Cell 4 Negative)	—	Input
38	C4	Voltage Input for Cell 4 Positive (Cell 5 Negative)	—	Input
39	SW4	Balance Input for Cell 4 Positive (Cell 5 Negative)	—	Input
40	C5	Voltage Input for Cell 5 Positive (Cell 6 Negative)	—	Input
41	SW5	Balance Input for Cell 5 Positive (Cell 6 Negative)	—	Input
42	C6	Voltage Input for Cell 6 Positive (Cell 7 Negative)	—	Input
43	SW6	Balance Input for Cell 6 Positive (Cell 7 Negative)	—	Input
44	C7	Voltage Input for Cell 7 Positive (Cell 8 Negative)	—	Input
45	SW7	Balance Input for Cell 7 Positive (Cell 8 Negative)	—	Input
46	C8	Voltage Input for Cell 8 Positive (Cell 9 Negative)	—	Input
47	SW8	Balance Input for Cell 8 Positive (Cell 9 Negative)	—	Input
48	C9	Voltage Input for Cell 9 Positive (Cell 10 Negative)	—	Input
49	SW9	Balance Input for Cell 9 Positive (Cell 10 Negative)	—	Input
50	C10	Voltage Input for Cell 10 Positive (Cell 11 Negative)	—	Input
51	SW10	Balance Input for Cell 10 Positive (Cell 11 Negative)	—	Input
52	C11	Voltage Input for Cell 11 Positive (Cell 12 Negative)	—	Input
53	SW11	Balance Input for Cell 11 Positive (Cell 12 Negative)	—	Input
54	C12	Voltage Input for Cell 12 Positive (Cell 13 Negative)	—	Input
55	SW12	Balance Input for Cell 12 Positive (Cell 13 Negative)	—	Input
56	C13	Voltage Input for Cell 13 Positive (Cell 14 Negative)	—	Input
57	SW13	Balance Input for Cell 13 Positive (Cell 14 Negative)	—	Input
58	C14	Voltage Input for Cell 14 Positive	—	Input
59	SW14	Balance Input for Cell 14 Positive	—	Input
60	VBLK	Block Voltage Positive Input. Internal pulldown resistor of R_{VBLK} .	DCIN	Input
61	DCIN	DC Supply for the Low-Voltage Regulator, HV Charge Pump, and SHDNL Charge Pump. Connect to a voltage source between 9V and 65V through a 100 Ω series resistor. Bypass with a 100V, 2.2 μ F capacitor to ground.	—	Power
62	CPN	Negative Capacitor Connection for the HV Charge Pump	—	Power
63	CPP	Positive Capacitor Connection for the HV Charge Pump. Connect a 100V, 0.1 μ F capacitor from CPP to CPN.	—	Power
64	HV	Decoupling Capacitor Connection for the HV Charge Pump. Bypass with a 50V, 4.7 μ F capacitor to DCIN.	—	Power

Detailed Description

The data-acquisition system consists of the major blocks shown in [Figure 1](#) and described in [Table 1](#).

Table 1. System Blocks

BLOCK	DESCRIPTION
ADC	Analog-to-digital converter. Uses a 12-bit successive-approximation register (SAR) with a reference voltage of 2.307V and is supplied by V_{AA} .
HVMUX	14-channel high-voltage (65V) differential multiplexer for the C0–C14 inputs.
HV CHARGE PUMP	High-voltage charge-pump supply for the HVMUX, ALTMUX, BALSWS, and LSAMP circuits that must switch high-voltage signals. Supplied by DCIN.
LSAMP1	Level-shifting amplifier with a gain of 6/13. The result is a 5V differential signal attenuated to 2.307V, which is the reference voltage for the ADC.
LVMUX	Multiplexes various low-voltage signals including the level-shifted signals and temperature signals to the ADC for subsequent A-to-D conversion.
ALTMUX	12-channel, high-voltage differential multiplexer for the SW0–SW14 inputs.
BALSWS	Cell-balancing switches.
LINREG	3.3V (V_{AA}) linear regulator used to power the ADC and digital logic. Supplied by DCIN.
REF	2.307V precision reference voltage for ADC and LINREG. Temperature-compensated.
ALTREF	1.242V precision reference voltage used for diagnostics.
16MHz OSC	16MHz oscillator with 2% accuracy for clocking state machines and UART timing.
32kHz OSC	32,768Hz oscillator for driving charge pumps and timers.
LOWER PORT	Differential UART for communication with host or down-stack devices. Autodetects baud rates of 0.5Mbps, 1Mbps, or 2Mbps.
UPPER PORT	Differential UART for communication with up-stack devices.
CONTROL AND STATUS	ALUs, control logic, and data registers.
DIE TEMP	A proportional-to-absolute-temperature (PTAT) voltage source used to measure the die temperature.
COMPARATOR	A comparator path to detect OV/UV for cell voltage and AUXIN.
LSAMP2	Level-shifting amplifier with a gain of 1. The result is a 5V differential signal that is compared against programmable OV and UV DAC thresholds.
SPI INTERFACE	SPI interface for communication with host.

Block Diagrams

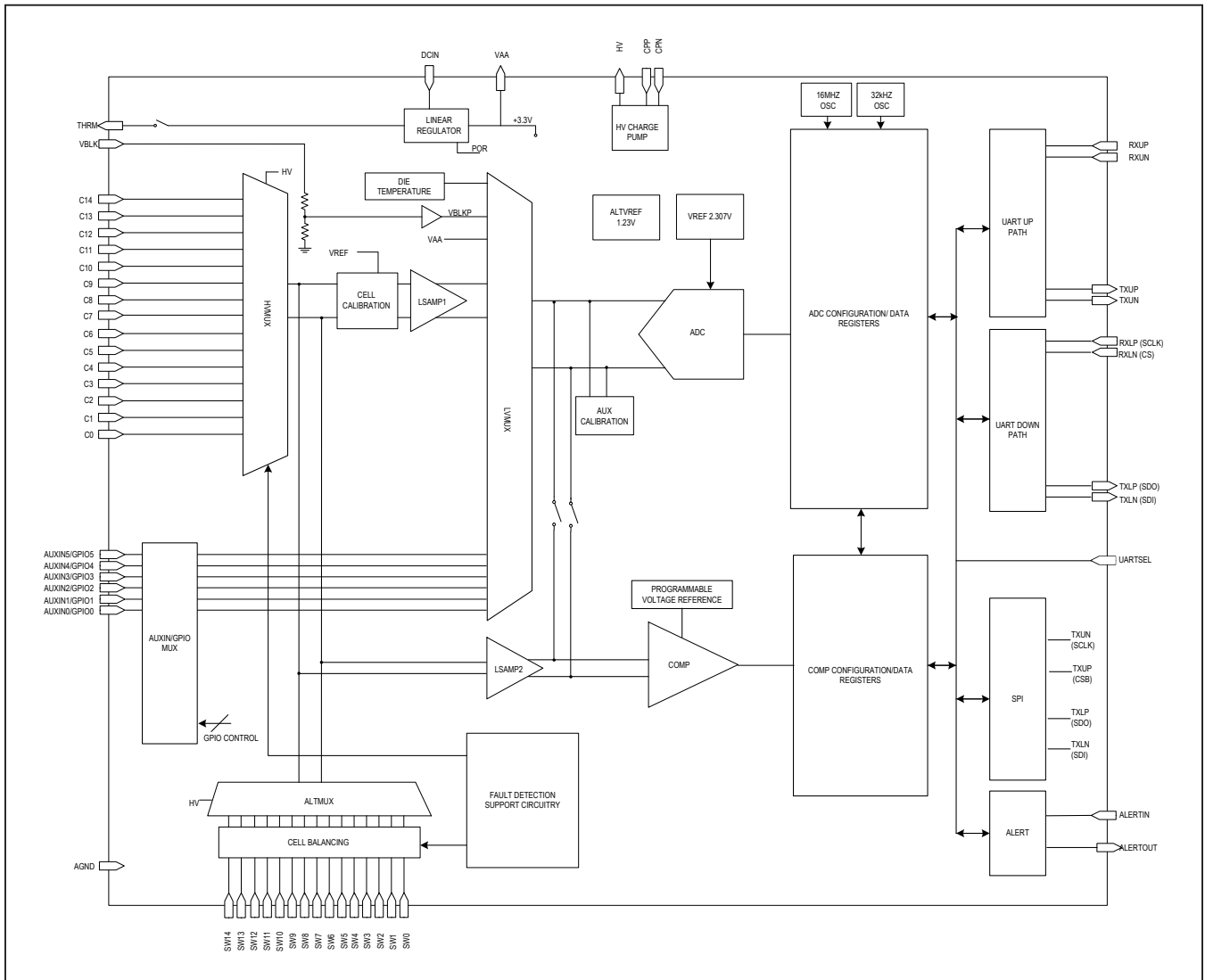

Figure 1. MAX17853 Functional Block Diagram

Block Diagrams (continued)

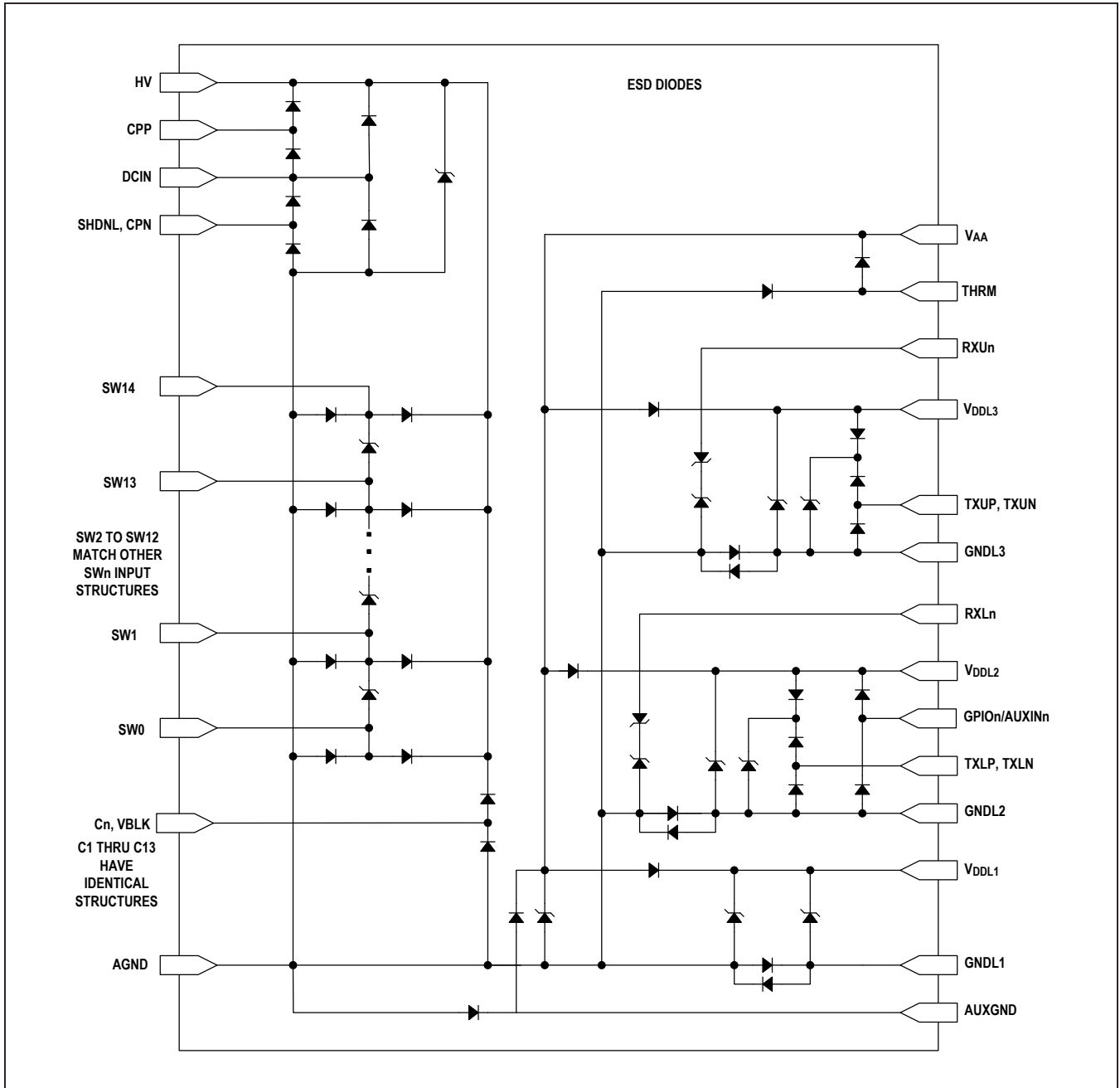

Figure 2. MAX17853 ESD Diodes

Notes:

- 1) All diodes are rated for ESD-clamping conditions; they are not intended to accurately clamp DC voltages.
- 2) All diodes have a parasitic diode from AGND to their cathode that is omitted for clarity. These parasitic diodes have their anode at AGND.

Block Diagrams (continued)

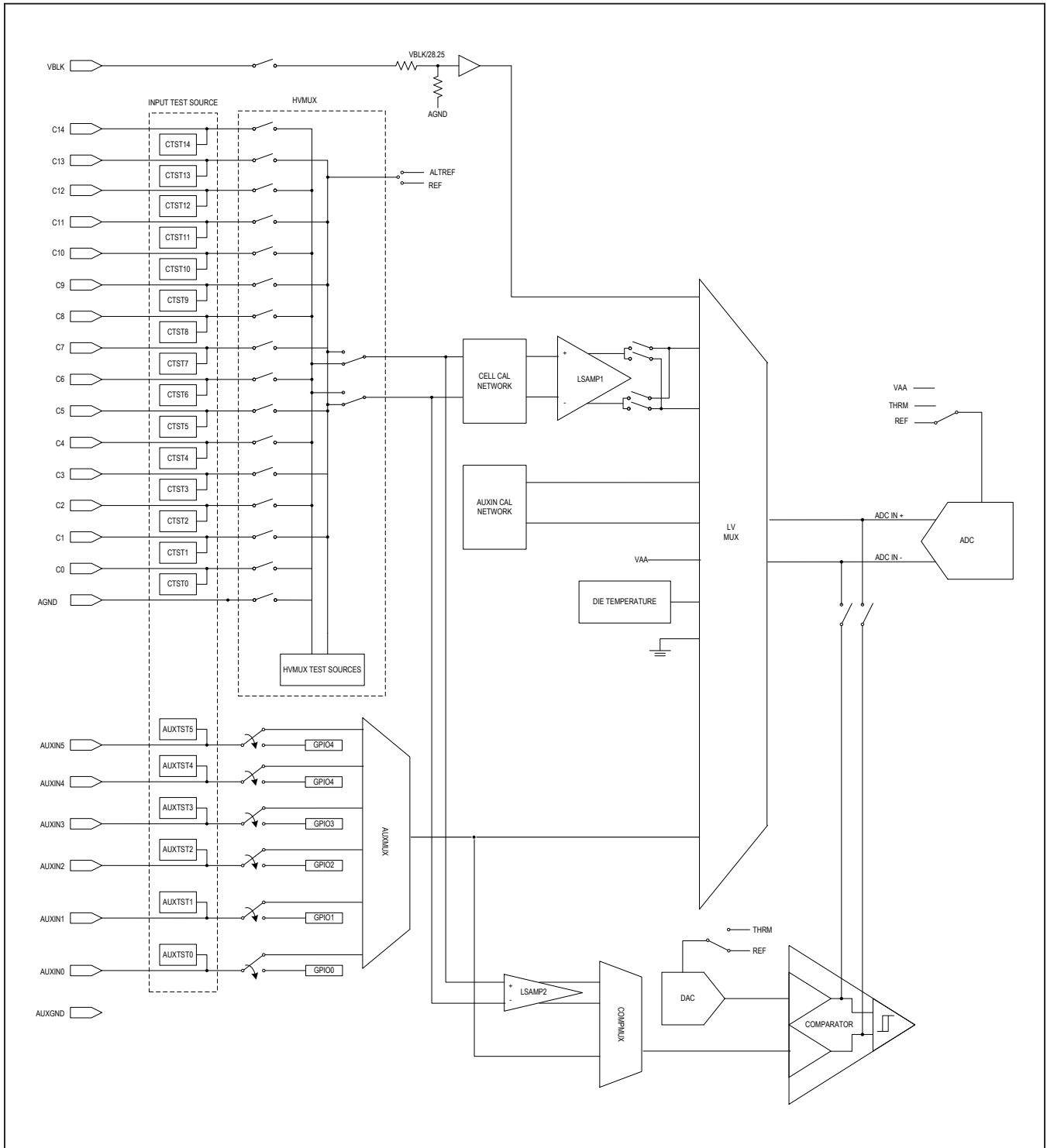

Figure 3. MAX17853 Analog Front-End

Terms, Definitions, and Data Conventions

Data Acquisition

Data acquisition is composed of the distinct processes defined in [Table 2](#) and controlled by various configuration registers described in this section.

Configuration changes should be made prior to the acquisition in which the changes are to be effected.

Data Conventions

Representation of data follows the conventions shown in [Table 3](#). All registers are 16-bit words.

Factory Trimming

The acquisition system is trimmed at the factory. The trim parameters are stored in a ROM consisting of 11 read-only registers (OTP2–OTP12). ROMCRC is an 8-bit CRC value based on the calibration ROM and is stored in OTP12[15:8] at the factory. ROMCRC can be used to check the integrity of the trim, as described in the [Diagnostics](#) section.

The factory trim can be further supplemented with a user on-demand calibration when used in a specific customer application.

Table 2. Data-Acquisition Process

PROCESS	DESCRIPTION
Conversion	The ADC samples a single input channel, converts it into a 12-bit binary value, and stores it in an ALU register.
Scan	The ADC sequentially performs conversions on all enabled cell-input channels.
Measurement Cycle or Sample	The ADC performs two scans for the purpose of minimizing errors in uncalibrated configurations. The conversions (two for each input channel) are averaged together to form a single 14-bit binary value called a measurement or sample.
Acquisition or Acquisition Mode	If oversampling is enabled, the ADC takes sequential measurements and averages them together to form one 14-bit binary value for each input channel sampled. If there is no oversampling, the acquisition is essentially a single measurement cycle.
Calibration	The measurement and correction factor applied to a measurement cycle or sample based on current operating conditions. Calibration can be applied to a single scan in addition to the two-scan process to minimize errors in the same fashion as a measurement cycle or sample Note: A single scan should not be implemented without a valid calibration for the accuracy requirements defined in the Electrical Characteristics section.

Table 3. Numeric Conventions

DESCRIPTION	CONVENTION	EXAMPLE
Binary number	0b prefix	0b01100001 = 61h
Hexadecimal address	0x prefix	0x61
Hexadecimal data	h suffix	61h
Decimal data	d suffix	61d
Register bitfield	Register name [x]	STATUS15 = 1
Register field	Field name [x:y]	DA[4:0] = 0b01100 = 0Ch = 12d
Register field and bitfield	Register name:bitfield	ADDRESS:DA
Concatenated numbers	{xxxx, yyyy}	{DA[4:0], 0b001} = 61h

Factory-Programmed Device ID

The ID1 register together with ID2 provides a 32-bit manufacturing identification number, DEVID[31:0]. This ID will be unique among all devices with the same model type and version (VERSION:MOD,VER, respectively); taken together, VERSION, ID1, and ID2 provide a means to uniquely identify all devices shipped by the factory. Although not required, the manufacturing date information provided on the package provides further means of device tracking. A device ID of zero is invalid.

Introduction

The MAX17853 is a software-configured ASIL D data-acquisition system for both high-voltage- and low-voltage (48V)-rated applications, supporting a flexible configuration of cell-voltage measurements, pack-voltage measurements, temperature measurements, and auxiliary-voltage measurements. All measurements are synchronously sampled within an acquisition and have minimal delay between acquired samples. Additional programmability is available for balancing currents, as well as system-interconnect measurements (bus bars) to provide a complete measurement solution independent of hardware configuration.

The following sections describe device operation, feature set, and programming of the MAX17853.

Flexible Battery-Pack Configuration

The main supply voltage (DCIN) can be routed internally using the SW8–SW14 inputs of the highest stacked cell. This allows for a single hardware configuration to serve multiple battery modules without requiring external hardware or wiring-harness changes.

The flexible battery-pack configuration is enabled by default using the FLXPACKEN1/2 bit, to allow for internal powering conditions. If this configuration is not required, the DCIN can still be driven externally, which effectively

disables the flexible battery-pack configuration. Prior to SDHNL being actively controlled, the DCIN voltage is driven towards HV and clamped at the highest voltage applied at the SW8–SW14 inputs. When SHDNL is asserted, DCIN is driven to within 1V below the highest stacked cell, if no external DCIN is provided. In this case, the host must define the TOPCELL1[3:0] and TOPCELL2[3:0] of the stack by writing to the PACKCFG register and by asserting the FLXPCKEN1 and FLXPCKEN2 bits. TOPCELL_[3:0] selection configures the top-cell position if less than 14 channels are used. TOPCELL_[3:0] selections 0x0–0x7 and 0xF are not supported and are mapped to an OFF position (power-on default).

If FLXPACKEN1/2 is unintentionally deasserted while the SHDNL is driven high with no external DCIN connection, it is expected that voltage seen at the DCIN pin will fall at a rate proportional to the current consumption of the part and the external decoupling capacitance, until the POR threshold is reached. This resets the digital logic and returns the FLXPCKEN return to the desired power-on reset state.

If FLEXPCKEN1 and FLEXPCKEN2, or TOPCELL1 and TOPCELL2 are not the same, the power-on default values will be applied.

Note: It is important that TOPCELL1 and TOPCELL2 select the highest applied cell input, as an invalid configuration can create an internal path that would connect the highest battery voltage to the selected TOPCELL1/2 input.

A second mux internally connects VBLK to a selected cell input after the host defines the TOPCELL_[3:0] of the stack and asserts the FLXPCKEN_ bit. TOPBLOCK[3:0] selects the Cn pin to be connected to the VBLOCK resistive divider. 0xF (default) selects the VBLK pin. TOPBLOCK_ selections 0x0–0x7 are not supported and will be mapped to 0xF (VBLK, default).

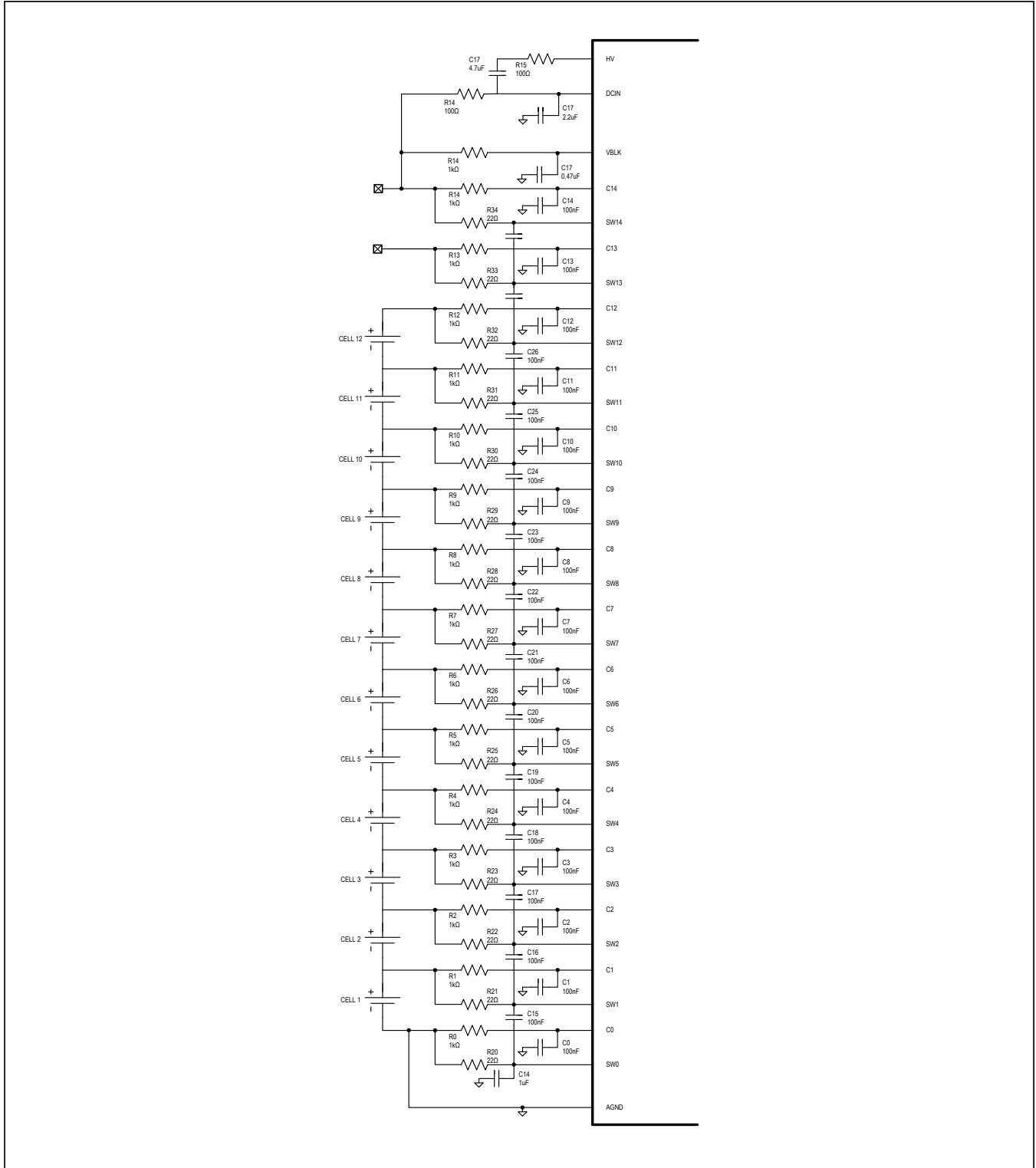

Figure 4. Flexible-Pack Configuration for 12-Cell Pack on 14-Channel CMC

Flexible-Pack Interaction with Acquisitions

If FLXPACKEN1/2 and FLXPCKSCAN are asserted, the switch input denoted in the TOPCELL1 and TOPCELL2 bitfields is disconnected from DCIN and the internal power consumption will be supplied by the external decoupling/hold-up capacitance on the DCIN pin. A 30µs delay will be inserted prior to the TOPCELL conversion, allowing the external switch-filter network to settle before converting the input voltage.

Note: FLXPCKSCAN only affects ALTMUX acquisitions. If the ALTMUX accuracy is not required for the application, no changes are required to the application circuit regardless of the FLXPCKSCAN setting. It is however, recommended to set FLXPCKSCAN=0 to ensure the quickest sampling rate is achieved.

Power-Multiplexing Operation (Cell Balancing)

The top two balancing switches should not be configured simultaneously while in manual Cell-Balancing mode when

the internal power multiplexing is configured. This configuration creates a voltage drop in the DCIN supply equivalent to a cell voltage that can result in large measurement errors of the top-cell reading with both the HVMUX and ALTMUX configured.

TOPCELL_[3:0] and FLXPCKEN_ must refer to the top cell in the pack and not a bus bar, if the top-used channel in the pack is a bus bar. TOPBLOCK_ can refer to cells above TOPCELL_.

Flexible Pack Alert

An ALRTDCINMUX is triggered to indicate a fault in the DCINMUX switch. A high condition indicates the enabled DCINMUX is not functioning properly in a Flex Pack application. Performance may be impacted, and/or other related faults may be issued. The ALRTDCINMUX is gated until clear of ALRTRST after power-up has occurred.

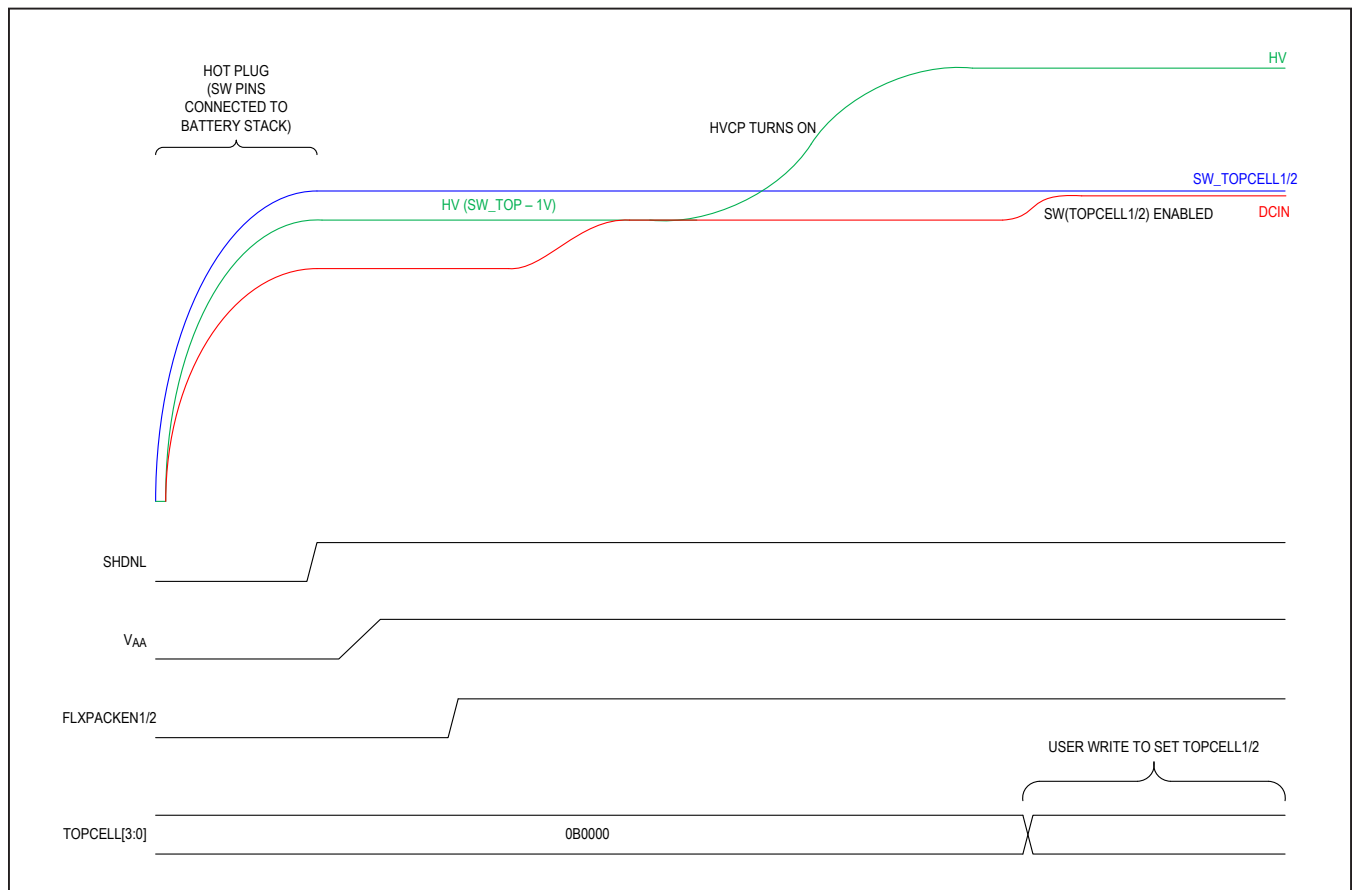

Figure 5. Flexible-Pack Power-On Timing

Cell Inputs

Up to 14 voltage measurements can be sampled differentially from the 15 cell inputs. The differential signal V_{CELLn} is defined as $V_{Cn} - V_{Cn-1}$ where $n = 1$ to 14.

The cell inputs are selected by the corresponding CELLEN bits in the MEASUREEN1 register. Additionally, the input path for the measurement acquisition is selected using SCANCTRL:ALTMUXSEL. The ALTMUXSEL bit allows for two different measurement configurations: HVMUX and ALTMUX acquisitions. The HVMUX path selection is used for the primary measurement acquisition due to the higher filtering achieved by the external input network. Alternatively, the ALTMUX path selection is primarily used for cell balancing and typically does not have a large RC

filter. Due to the parallelism of the external filter network, as well as the internal block structures, the ALTMUX path selection also allows for independent measurement redundancy improving safety performance and device robustness.

During the scan, the selected signal is multiplexed into the level-shifting amplifier (LSAMP1 or LSAMP2) as shown in Figure 6. Since the common-mode range of the input signals is 0V to 65V, the signal must be level-shifted to the common-mode range of the amplifier. Both ADC and comparator signal paths have a gain of 6/13 so that a 5V differential signal is attenuated to the ADC and Comparator full-scale reference voltage (V_{REF}).

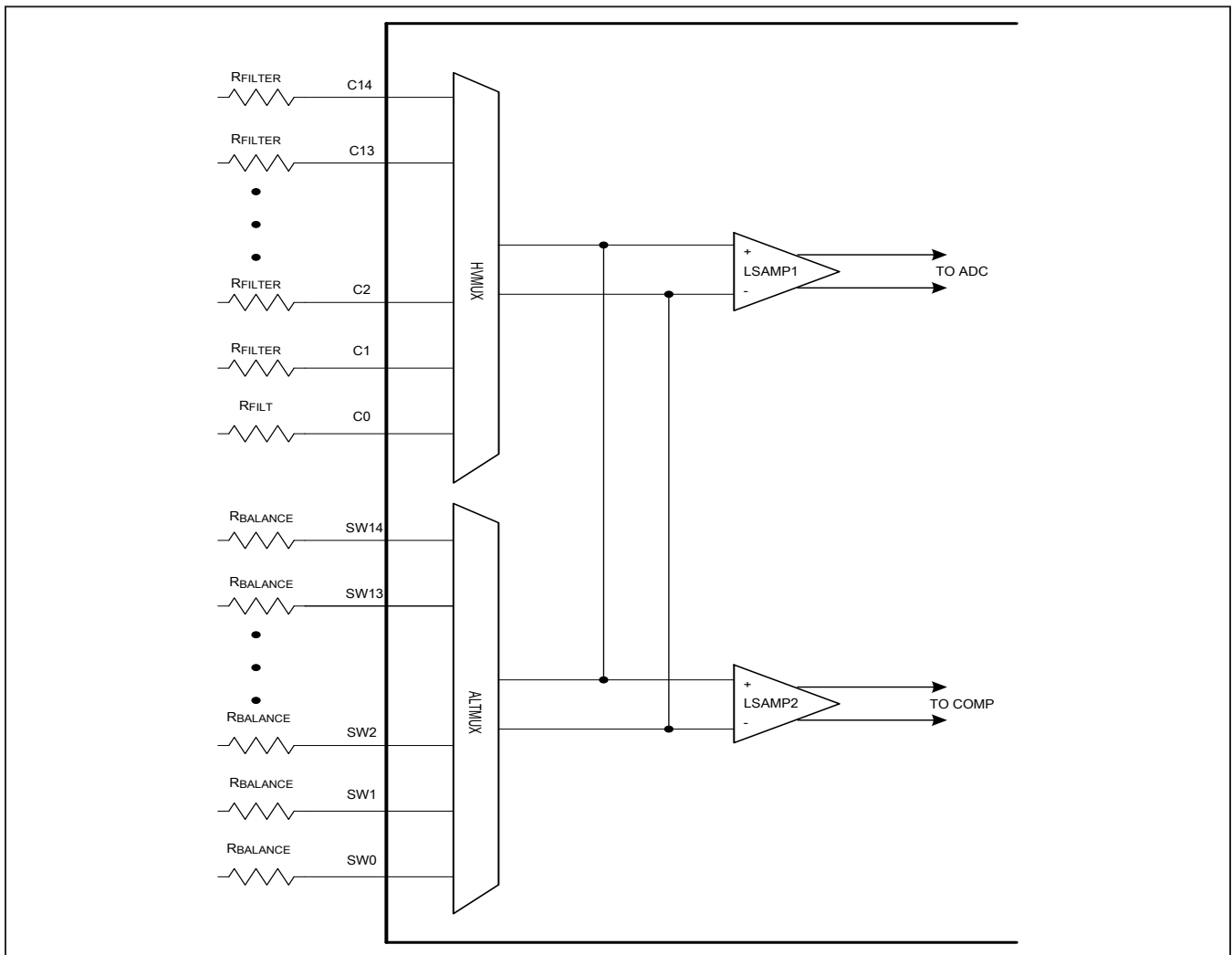

Figure 6. Cell Signal Path

Once the signal is properly conditioned, the ADC starts the conversion. The 12-bit conversion is stored in an ALU register where it can be averaged with subsequent conversions for increased resolution. The ALU output is a 14-bit value, relating to a 305µV voltage resolution, and is ultimately stored in a 16-bit register, CELLnREG, with the two least-significant bits 0. Disabled channels maintain their previous measurement result. Unless stated otherwise, measurement values are assumed to be 14-bit values. The 16-bit register values can be converted to 14-bit values by dividing by 4 (and vice-versa). To convert the measurement value in register CELLnREG to a voltage, convert the 14-bit hexadecimal value to a decimal value and then convert to voltage as follows:

$$V_{CELLn} = \frac{CELLnREG[15:2] \times 5 \text{ V}/16384}{CELLnREG[15:2] \times 305.176\mu\text{V}}$$

Bus-Bar Inputs

Bus-bar inputs can be applied to any of the 14 cell inputs. Due to the resistive nature of the bus bar, the current applied to the battery pack or discharged from the battery pack affect the polarity of the voltage measurement. To support this requirement, the POLARITY bits corresponding to the bus-bar location must be configured for bipolar conversion (POLARITY[n] = 1b).

Due to the negative voltage that can be generated across the bus bars SW_n to SW_{n-1} inputs, it is recommended to place an external Schottky diode in across these inputs to the reverse voltage see by the body diode of the internal balancing switch as shown below to shunt current away from the internal conduction path.

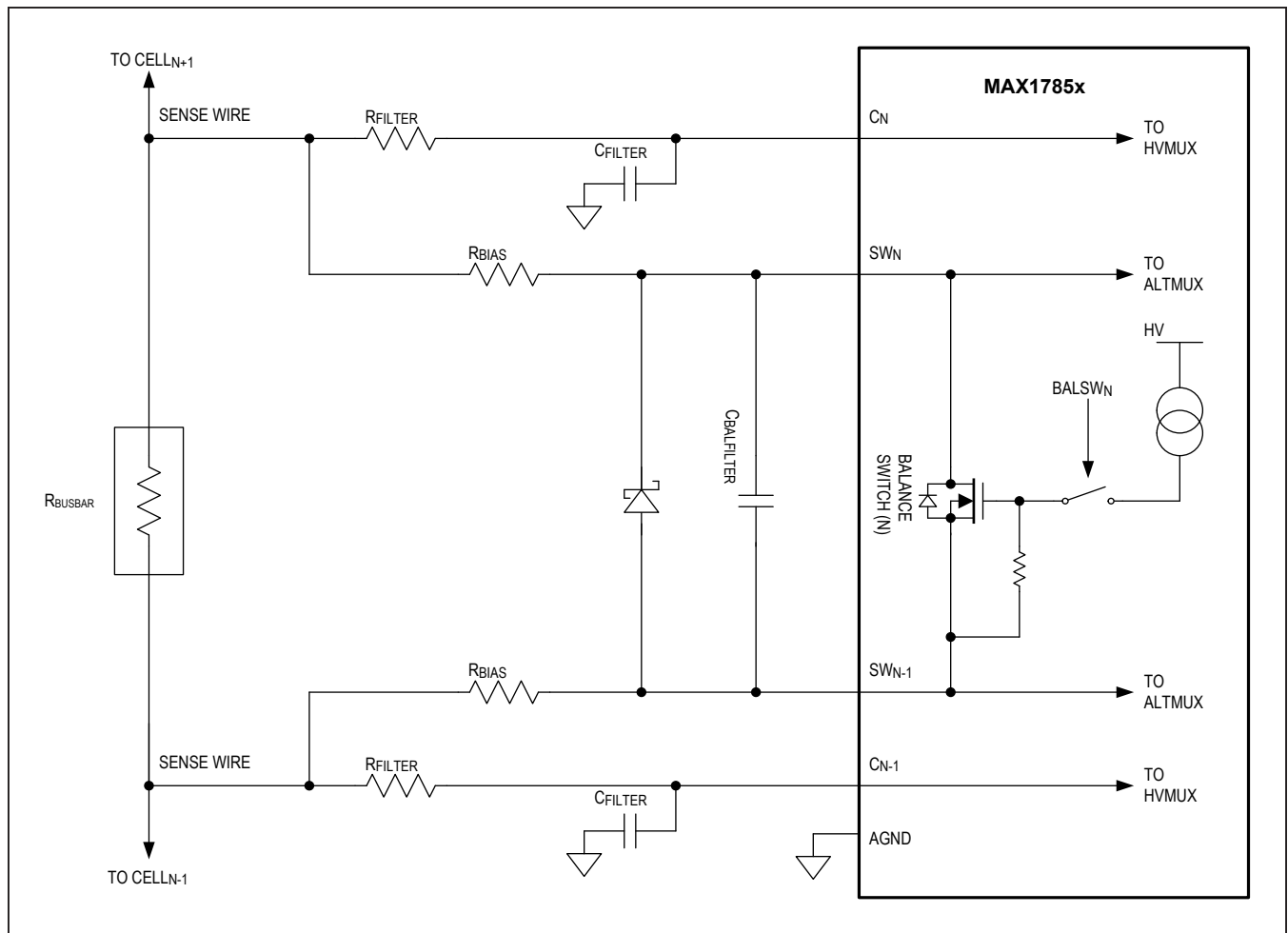

Figure 7. Bus-Bar Switch Configuration

Block-Voltage Input

The VBLK input pin to the MAX17853 allows for the pack voltage (total cell voltage) to be measured independently of summing the individual cell voltages from an acquisition. This comparison provides an extra layer of measurement redundancy within the system.

The VBLK voltage is attenuated by a voltage-divider of 28.17 for the acquisition process to translate the 65V full-scale block input voltage into the full-scale ADC input voltage (V_{REF})

Outside of the acquisition the VBLK input path is opened to avoid power consumption from the internal 10M Ω divider.

The measurement is enabled in a an acquisition by asserting BLOCKEN in MEASUREEN1 register. The measurement is stored in the VBLOCK[13:0] bits of the BLOCKREG register where each bit has a resolution of 3.967mV.

Auxiliary Inputs

The MAX17853 has 6 auxiliary ports that can be used to measure external temperatures, measure external voltages, or that can be re-purposed for digital functions (GPIO).

Auxiliary Inputs: Ratiometric Temperature Measurement

Individual auxiliary ports can be configured to measure external temperatures through enabling auxiliary measurements using the AUXEN bits in the MEASUREEN2 register as well as configuring the conversion voltage as ratiometric using the AUXREFSEL bits in the AUXREFCTRL register.

Note: If the individual auxiliary port is configured as a GPIO using GPIOEN bits in the AUXGPIOCFG register while the corresponding AUXEN bit is high, then the auxiliary setting be ignored and the port be configured as a GPIO.

The ratiometric configuration selects the conversion voltage of both the ADC and Comparator to V_{AA} , while also outputting V_{AA} on the THRM pin. An external resistive divider can then be created with a pullup resistor to the THRM pin and a NTC connected to the AUXGND pin as shown in [Figure 9](#):

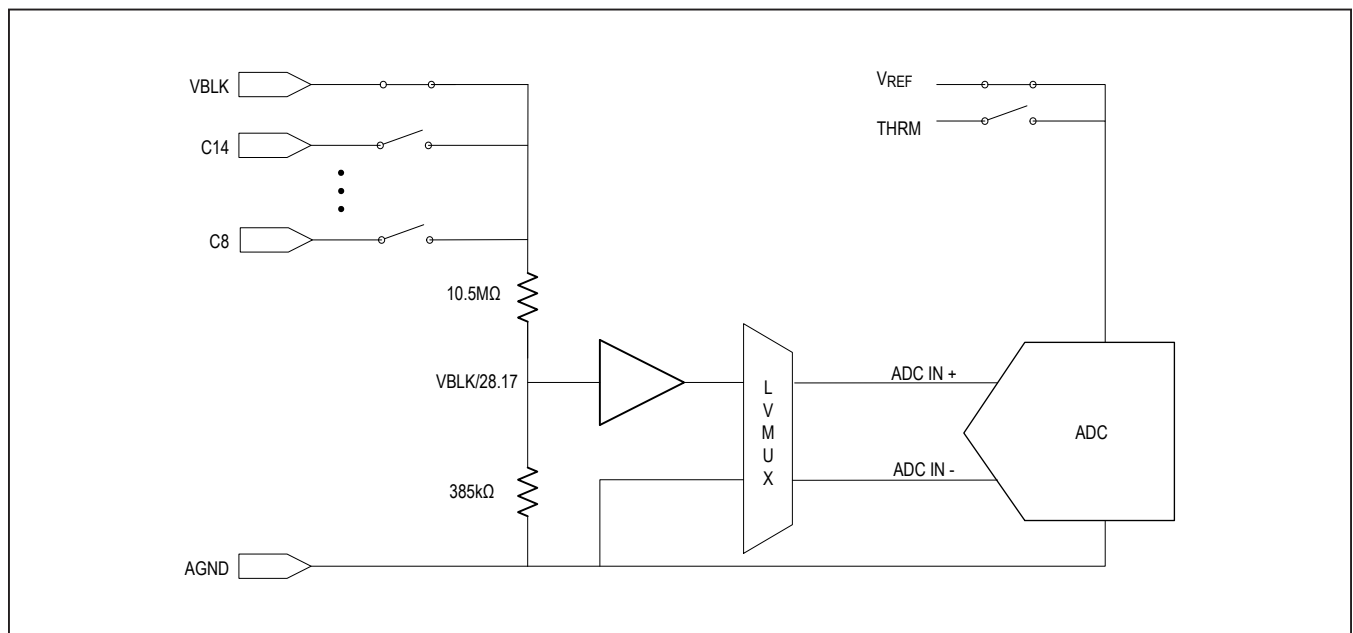

Figure 8. Block-Measurement Path

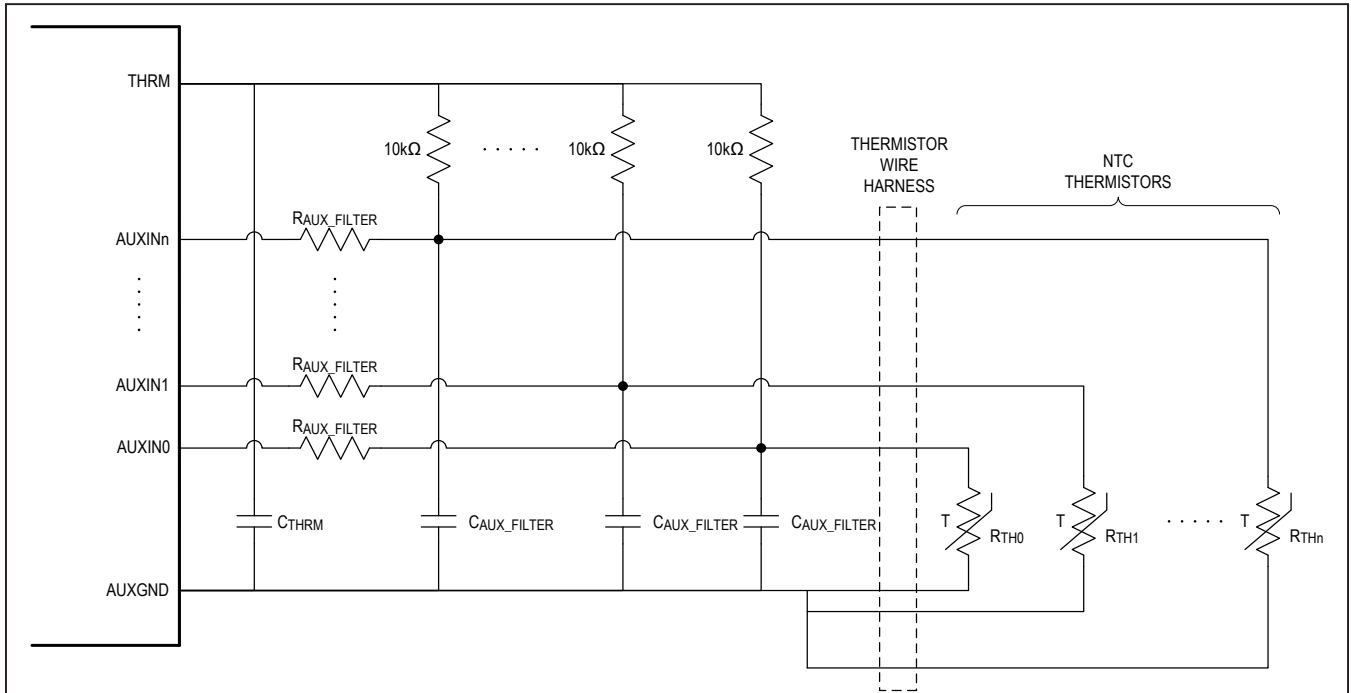

Figure 9. Auxiliary Application Circuit

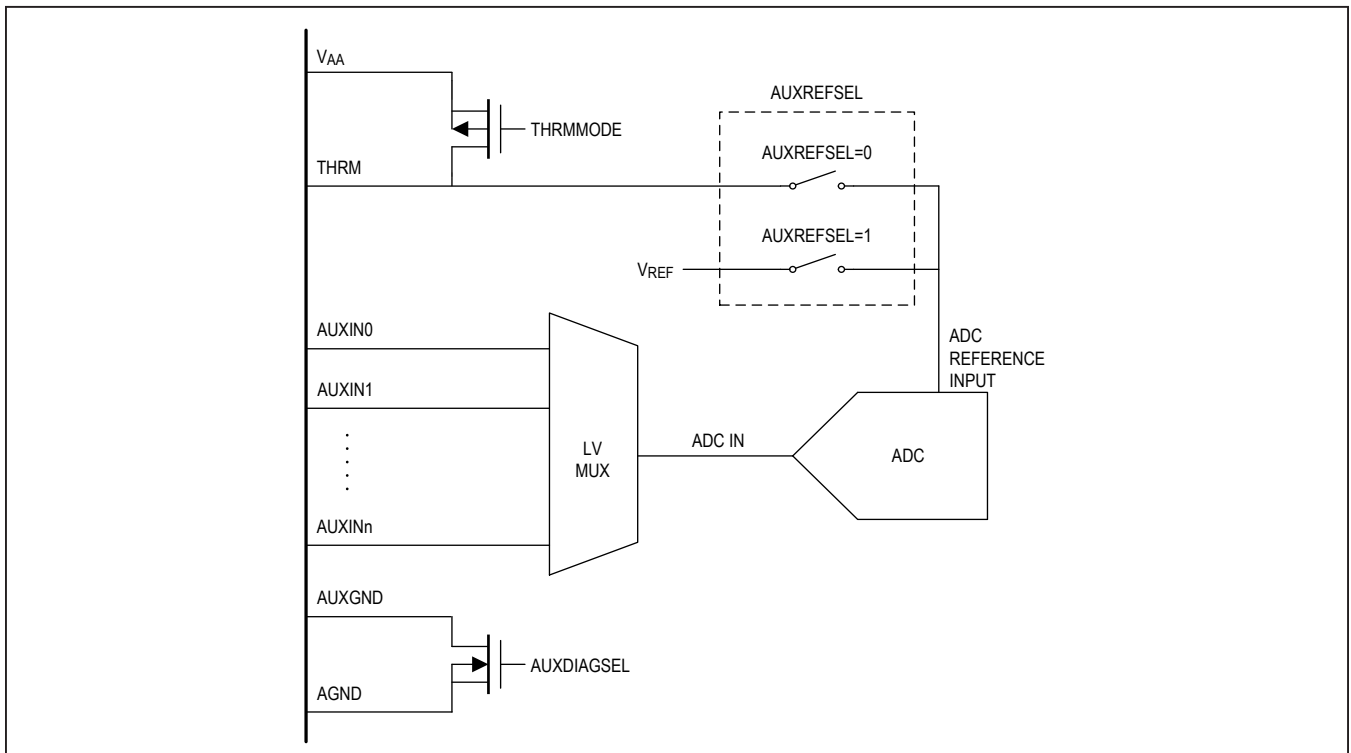

Figure 10. Auxiliary-Temperature Measurements

Explicit control on the THRM pin output is provided using the THRM_{MODE} bits in the ACQCFG register. Setting THRM_{MODE} to 00b or 01b enables automatic mode where the THRM switch be closed at the beginning of an acquisition. Setting THRM_{MODE} = 11b enables manual mode where the THRM switch is always closed. The ability to configure THRM_{MODE} allows for the application tradeoffs between the external NTC network's power consumption on V_{AA} and the need to settle the external NTC network to achieve the highest accuracy measurements.

Depending on the external temperature network, there may be insufficient settling time to provide accurate measurements. To support the flexibility for different networks, the AUX_{TIME} bits in the AUX_{TIME}REG register may be configured to impose a fixed delay of 0ms to 6.14ms prior

to the first AUX_{INn} measurement. For an acquisition with nondeterministic scan rates the AUX_{TIME} be allowed to settle through the cell, block, and diagnostic measurement intervals of the first scan. However, for acquisitions requiring deterministic timing, such as 50Hz/100Hz rejection and 60Hz/120Hz rejection, the AUX_{TIME} be applied prior to the beginning of the acquisition. Refer to the Oversampling section for further details on FOSR and deterministic acquisitions.

The auxiliary measurements are oversampled to 14-bit values using the OVSAMPL bits in the SCANCTRL register and the output of each auxiliary measurement is stored in the corresponding AUX0 to AUX6 registers. Refer to the Oversampling section and ADC, Comparator, and ADC+COMP Acquisitions sections for further details.

Table 4. THRM Output

MODE	THRM MODE	DESCRIPTION
Automatic	00b	THRM outputs V_{AA} (dynamically enabled at the beginning of the acquisition and disabled at the end of the acquisition)
	01b	
Manual	10b	THRM output disabled (static)
	11b	THRM outputs V_{AA} (static)

Table 5. AUX_{TIME}

AUX _{TIME} [9:0]	ADDITIONAL SETTLING TIME PER ENABLED AUXILIARY CHANNEL = (AUX _{TIME} x 6 μ s)
0x000	0 μ s
0x001	6 μ s
0x002	12 μ s
...	...
0x3FF	6138 μ s

Ratiometric Auxiliary Input Range

Temperature measurements are converted ratiometrically to eliminate error due to the biasing of the NTC network. Thus, the conversion range is proportional to the V_{THRM} (V_{AA}) reference as shown below.

Both ADC and comparator conversions use the same reference during the conversion and thus have the same input range; however, the resolution for both differ in accordance with [Table 6](#) and [Table 7](#).

Computing Temperature

As shown in [Figure 9](#):

$$V_{AUXINn} = V_{THRM} \times R_{TH} / (10k\Omega + R_{TH})$$

This measurement is stored in the AUXn register. The thermistor resistance can then be solved as follows:

$$R_{TH} = (V_{AUXINn} \times 10k\Omega) / (V_{THRM} - V_{AUXINn})$$

where $V_{THRM} = 3.3V$ (nom)

The resistance of an NTC thermistor increases as the temperature decreases and is typically specified by its resistance $R_0 = 10k\Omega$ at $T_0 = 25^\circ C = 298.15K$ and a material constant β (3400K typical). To the first order, the resistance R_{TH} at a temperature T in Kelvin can be computed as follows:

$$R_{TH} = R_0 \times e^{\left(\beta \times \left(\frac{1}{T} - \frac{1}{T_0} \right) \right)}$$

The temperature T of the thermistor (in $^\circ C$) can then be calculated as follows:

$$T \text{ (in } ^\circ C) = (\beta / (\ln(R_{TH}/10k\Omega) + (\beta/298.15K)) - 273.15K)$$

Table 6. Auxiliary-Temperature Input Range: ADC

AUXILIARY INPUT VOLTAGE	AUXn (14 BITS)		AUXNREG[15:0] (16 BITS)
	Hexadecimal	Decimal	
Ratiometric mode			
0V	0000h	0d	0000h
$V_{AA}/2$	2000h	8192d	8000h
V_{AA}	3FFFh	16383d	FFFCh

Table 7. Auxiliary-Temperature Input Range: Comparator

AUXILIARY INPUT VOLTAGE	COMPOVTH, COMPUVTH, COMPAUXROVTH, COMPAUXRUVTH, COMPAUXAOTH, COMPAUXAUVTH (10 BITS)		COMPOVTHREG[15:0], COMPUVTHREG[15:0], COMPAUXROVTHREG[15:0], COMPAUXRUVTHREG[15:0], COMPAUXAOTHREG[15:0], COMPAUXAUVTHREG[15:0] (16 BITS)
	Hexadecimal	Decimal	
Ratiometric mode			
0V	000h	0d	0000h
$V_{AA}/2$	200h	512d	8000h
V_{AA}	3FFh	1024d	FFC0h

Auxiliary Inputs: Absolute-Voltage Measurements

Individual auxiliary ports can be configured to measure absolute voltages through enabling auxiliary measurements using the AUXEN bits in the MEASUREEN2 register as well as configuring the conversion voltage as absolute using the AUXREFSEL bits in the AUXREFCTRL register.

The absolute configuration selects the conversion voltage of both the ADC and Comparator to V_{REF} . An external voltage can be accurately measured as long as the voltage remains below V_{REF} . If higher voltages are required to be measured, a resistive divider must be used to ensure that maximum auxiliary input does not exceed V_{REF} ; otherwise, the voltage measurements saturate to full scale. Additionally, the user should be careful, so if a single-point failure on the external network occurs, the maximum auxiliary input doesn't exceed the absolute maximum rating on the port.

If all AUXREFSEL bits are set to 0b1 (using V_{REF} for the ADC reference), it is recommended that THRMODE be set to 0b10 (THRM switch always OFF).

Absolute Auxiliary Input Range

Absolute voltage measurements are converted using a fixed precision reference (V_{REF}). All voltages must meet the input-range requirements; otherwise, the digital output

will saturate and result in a loss of resolution. Both ADC and comparator conversions use the the same reference during the conversion but have different resolutions as shown in [Table 8](#) and [Table 9](#).

Auxiliary Inputs: Mixed-Mode Measurements

Ratiometric measurements and absolute-voltage measurements can both be performed during the same acquisition. Each measurement type has individual OV and UV alert-threshold settings, as described in the [Measurement Alerts](#) section.

Note: Auxiliary mixed-mode measurement data for the ADC is output to the AUXn registers. The appropriate conversion, as determined by the AUXREFSEL configuration, must be applied to obtain correct voltage reading.

Ratiometric-Voltage Conversion:

$$V_{AUXn} = AUXn[14:0] \times V_{AA} / 16384d = AUXn[14:0] \times 201.42\mu V, \text{ or alternatively } AUXnREG[15:2] \times 201.42\mu V$$

where V_{AA} is nominally 3.3V

Absolute-Voltage Conversion:

$$V_{AUXn} = AUXn[14:0] \times V_{REF} / 16384d = AUXn[14:0] \times 140.81\mu V, \text{ or alternatively } AUXnREG[15:2] \times 140.81\mu V$$

Table 8. Auxiliary-Voltage Input Range: ADC

AUXILIARY-INPUT VOLTAGE	AUXn (14 BITS)		AUXNREG[15:0] (16 BITS)
	Hexadecimal	Decimal	
Absolute Mode			
0V	0000h	0d	0000h
$V_{REF}/2$	2000h	8192d	8000h
V_{REF}	3FFFh	16383d	FFFCh

Table 9. Auxiliary-Voltage Input Range: Comparator

AUXILIARY-INPUT VOLTAGE	COMPOVTH, COMPUVTH, COMPAUXROVTH, COMPAUXRUVTH, COMPAUXAOTH, COMPAUXAUVTH (10 BITS)		COMPOVTHREG[15:0], COMPUVTHREG[15:0], COMPAUXROVTHREG[15:0], COMPAUXRUVTHREG[15:0], COMPAUXAOTHREG[15:0], COMPAUXAUVTHREG[15:0] (16 BITS)
	Hexadecimal	Decimal	
Absolute mode			
0V	000h	0d	0000h
$V_{REF}/2$	200h	512d	8000h
V_{REF}	3FFh	1024d	FFC0h

Auxiliary-Input Protection

The voltage on the AUXIN0–AUXIN5 pins should never exceed V_{AA} when configured as an auxiliary input. If this condition does occur, the affected input self-protects, becoming an open circuit. The associated ALRTAUXPRTCT bit will be set indicating the overvoltage condition. To retry AUX operation and clear the fault condition, the user must rewrite the desired configuration to the AUXGPIOCFG register.

All six ALRTAUXPRTCT bits will be logically OR'd together to form the ALRTAUXPRTCTSUM bit in the FMEA2 register.

GPIO Configuration

Any of the six auxiliary ports can be configured as a general-purpose input/output (GPIO) using the GPIOEN bits in the AUXGPIOCFG register. When a GPIOEN bit is high, the corresponding auxiliary port is configured as a GPIO. When a GPIOEN bit is low, the corresponding GPIO buffer is three-stated, and the pin is configured as an auxiliary-voltage input.

In the GPIO configuration, the I/O status is determined by the GPIODIR bits of the AUXGPIOCFG register. When a GPIODIR bit is programmed to 0b0, the corresponding port is configured as a digital input. The digital input has a $2M\Omega$ pulldown resistance to ensure the input does not float and cause excessive power dissipation. When the GPIODIR bit is programmed to 0b1, the pin is configured as a digital output. Each GPIO port configured as a digital output can be configured to drive a logic-high level or logic-low level determined by the assignment in the GPIODRV bits of the GPIOCFG register.

The GPIORD bits in the GPIOCFG register monitor the pin logic level, regardless of whether the port is defined as an input or an output. If a pin is configured as an auxiliary-voltage input (GPIOEN=0b0), the corresponding GPIORD bit always reads back 0b0.

Table 10. GPIO/Auxiliary Enable Selection

GPIOEN	FUNCTION
0	Auxiliary Input
1	GPIO

Table 11. GPIO Configuration

GPIOEN	GPIODIR	FUNCTION
0	x	Auxiliary Input
1	0	Digital Input
1	1	Digital Output

Operational Modes

There are three different operational modes supported, shutdown mode, standby mode, and acquisition mode. Shutdown mode is controlled by the applied voltage on the SHDNL pin. When the applied voltage is below V_{IL_SHDNL} the device is in an ultra-low-power shutdown mode, and the various elements of the internal circuitry are disabled. If the voltage is above V_{IH_SHDNL} , the device is in standby mode and act upon qualified interface commands. The device remains in standby mode until the user commands an acquisition, at which point the device transitions into acquisition mode until completed, as signaled by SCANDONE. Alternatively, the transition from sleep mode to acquisition mode will be handled independent of user interaction, only when long-term autonomous cell balancing with voltage measurements are enabled (see the [Cell Balancing](#) section for further information).

The sections that follow further detail the operational modes and device interactions.

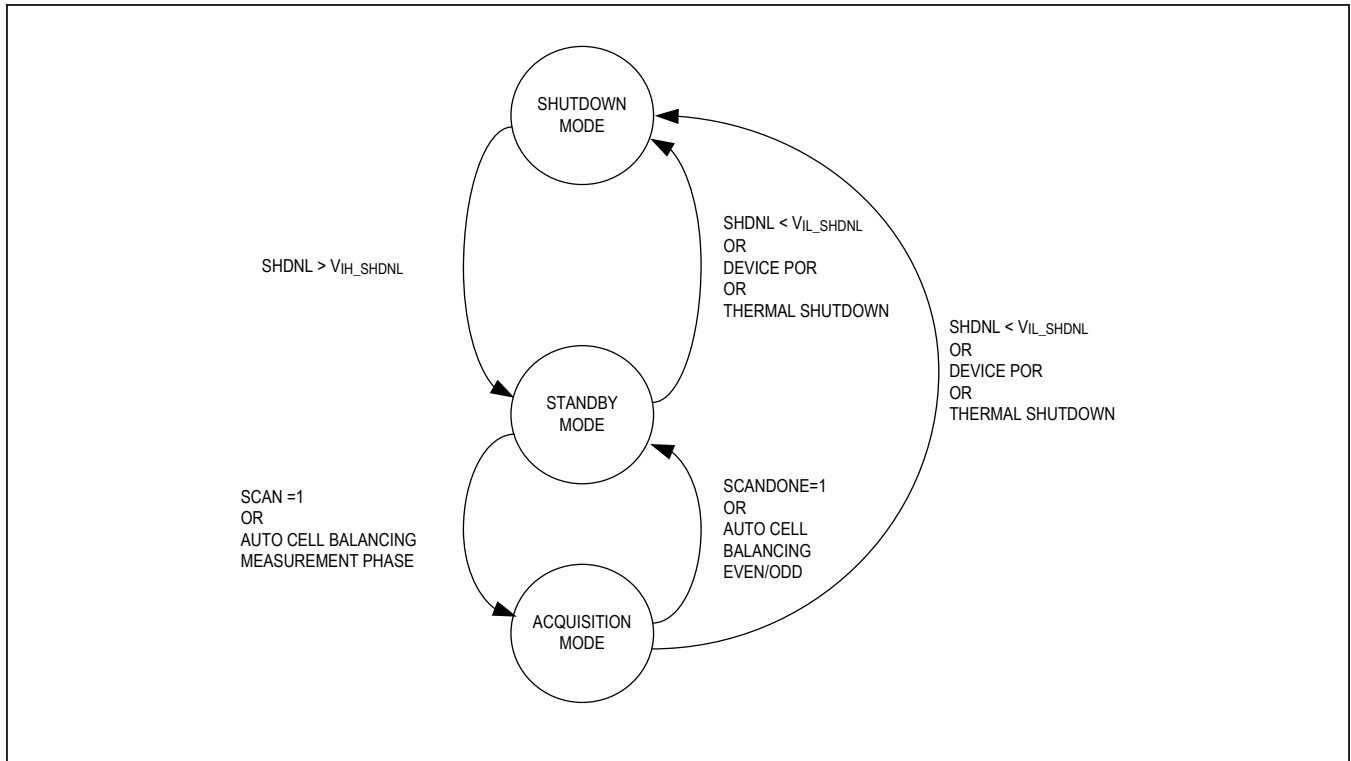

Figure 11. Operational-Mode State Diagram

Power-On (Standby Mode)

The configuration of the communication interface, as defined by the UARTSEL pin, determine the appropriate method to transition the device from shutdown mode into standby mode.

When configured as a differential UART interface (UARTSEL > V_{IH}), the SHDNL input can be driven externally above the V_{IH_SHDNL} threshold, or driven using internal charge pumps on the UART RXLP/RXLN and RXUP/RXUN inputs. If the SHDNL pin has no external connection to a host controller, the device must rely on the UART interface to drive the external network on the SHDNL pin. The recommended configuration with a 1nF capacitor allows the device to drive the SHDNL pin above V_{IH_SHDNL} in 200µs. The charge pump self-regulates to V_{SHDNLIMIT} and can maintain V_{SHDNL} at a logic one even with the UART idles 98% of the time. The internal charge-pump operation requires a differential UART signal.

Note: When configured as a single-ended UART interface, the SHDNL pin must be driven by an external connection to a host controller. The power-on of the device can then be controlled by the host driving the SHDNL pin above the V_{IH_SHDNL} threshold.

When configured as an SPI interface selection (UARTSEL < V_{IL}), the SHDNL input must be driven externally, as done with the single-ended UART configuration. It is recommended that the unused RXLP/RXLN and RXUP/RXUN inputs should be pulled low to ensure that the charge pump remains inactive and does not inadvertently contend with the external driver.

Once the V_{IH_SHDNL} threshold is reached, the LDO output is enabled and V_{AA} output voltage begins to rise. At 3V (typ), the POR signal is deasserted and the oscillators and HV charge pump is stable, the logic is enabled and the ALRTRST status bit set. The device is fully operational (standby mode) within 1ms from the time communication is first received in shutdown mode. [Figure 12](#) details the power-on state transition.

Shutdown-to-Standby State Diagram

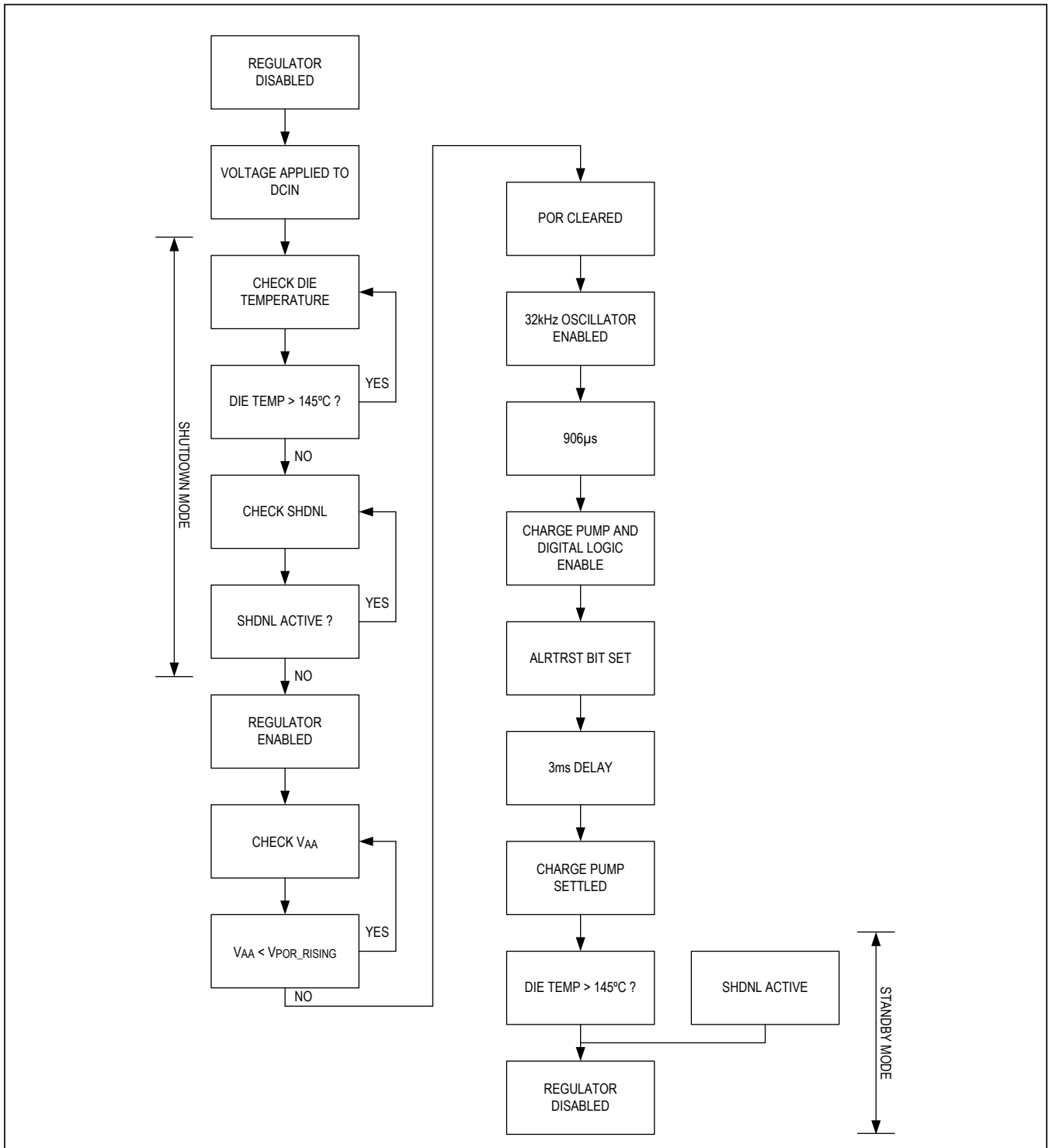

Figure 12. Power-On Sequence

Shutdown Mode

Shutdown mode is entered when $SHDNL < V_{IL_SHDNL}$. In shutdown, the low-voltage regulator and HV charge pump are disabled as soon as the SHDNL pin goes low. When the V_{AA} and V_{DDL} decoupling capacitors discharge below the POR threshold (2.95V, typ) the device registers are reset. The device is then in an ultra-low-power state until SHDNL is brought high. The control to enter this state is achieved using separate methods depending on the interface configuration which has been optimized for the end application.

When the device is configured in UART communication ($UARTSEL > V_{IH_UARTSEL}$), shutdown is enabled by externally driving SHDNL low, stopping commanded and keep-alive communication through the differential UART, or commanding a register write to enable the FORCEPOR bit. In the latter two conditions, the rate at which shutdown mode is entered is controlled by the time constant associated with the external C_{SHDNL} and the equivalent resistance. Through halting communication to the device, there is no charge pumping and the capacitor discharges through an internal 10M Ω resistor with a 10ms time constant. If a faster shutdown rate is required, a 200k Ω resistor can be connected externally from SHDNL to AGND to create a 200 μ s time constant. Alternatively,

the FORCEPOR bitfield can be utilized, which enables a 4.7k Ω pulldown to create a 4.7 μ s time constant.

Note: When deciding on an external pulldown resistor to control the shutdown time, attention should be paid as this resistor creates a voltage-divider with the internal Emergency-Discharge mode pullup resistance and could force the device into shutdown unintentionally when HOLDSHDNL is enabled. It is therefore recommended to use a minimum 4.7k Ω resistor to avoid any interaction.

If only a register reset is required, the host can issue a soft-reset by enabling the SWPOR bitfield. This resets all non-interface-related device bitfields (UARTCFG, TXUIDLEHIZ, TXLIDLEHIZ, ADAPTTXEN, UARTHST, SFTYCSB, SFTYSCLK, SFTYSDI, SPIDRVINT, ALERTEN).

When the device is configured for SPI communication ($UARTSEL < V_{IL_UARTSEL}$), the recommended method to enter shutdown is enabled by externally driving SHDNL low. Although, not recommended, if the FORCEPOR bitfield will be utilized, the external driver must have some series-limiting resistance to ensure that a voltage-divider is created to allow SHDNL to fall below V_{IL_SHDNL} .

Table 12. Shutdown Timing

SHUTDOWN METHOD	R _{PULLDOWN}		C _{SHDNL}	RC
1. External controller	N/A	External	1nF	N/A
2. External SHDNL resistance to AGND	4.7k Ω	External		4.7 μ s
3. Register configured FORCEPOR	4.7k Ω	Internal		4.7 μ s
4. Disconnect DCIN	200k Ω	External		200 μ s
5. Host places UART in idle mode	10M Ω	Internal		10,000 μ s

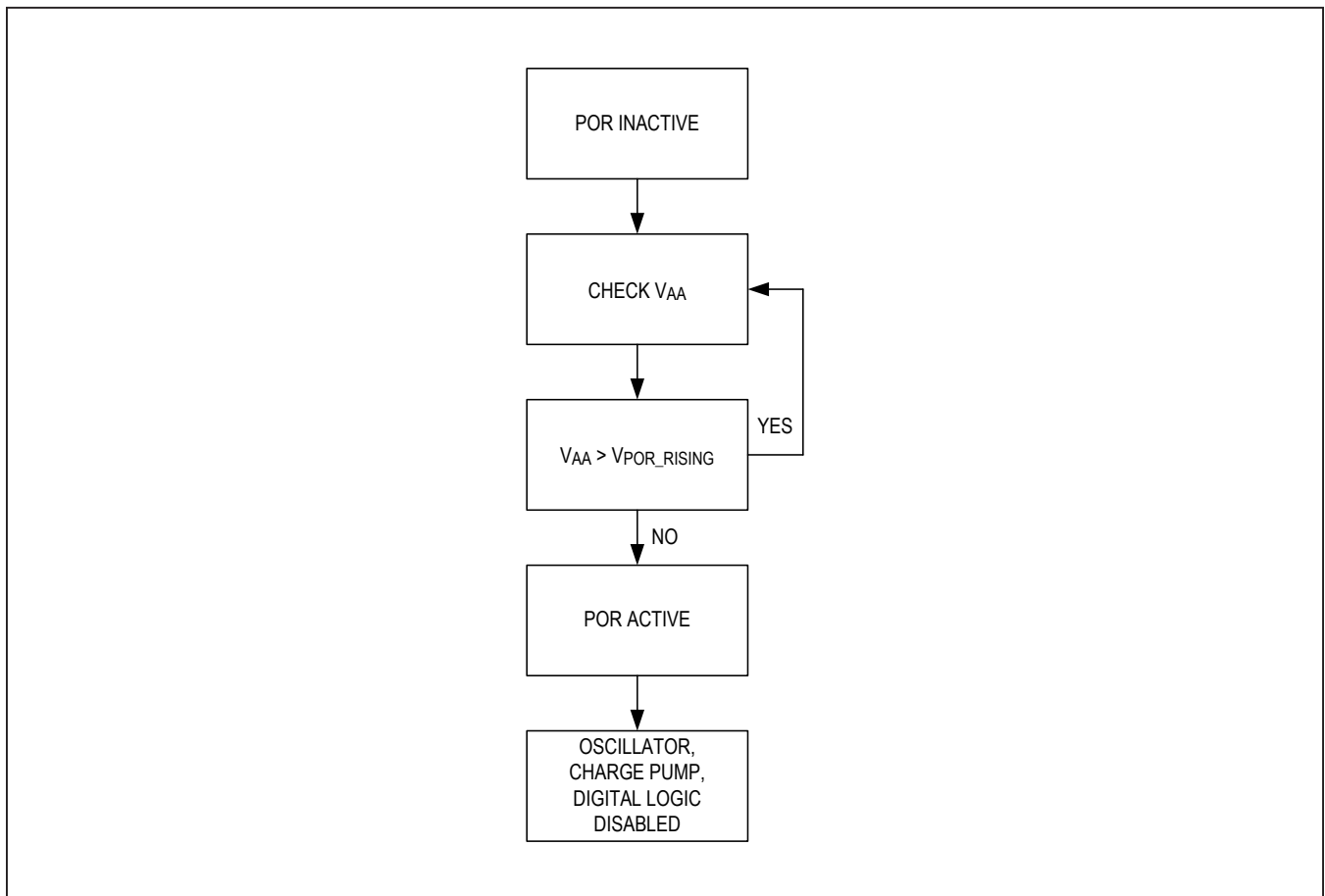
Shutdown State Diagram*Figure 13. Shutdown Sequence*

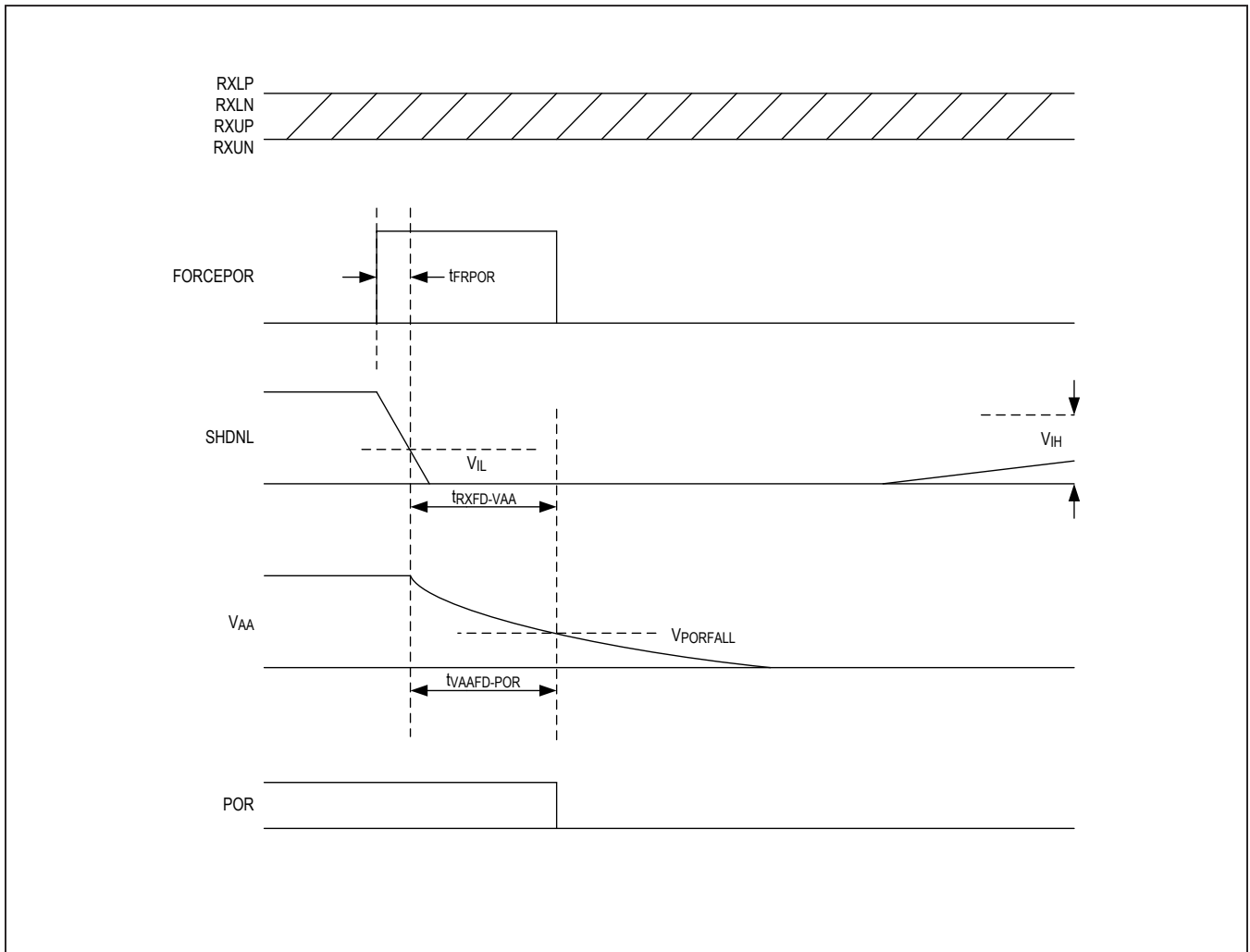

Figure 14. UART Operation (Shutdown Timing)

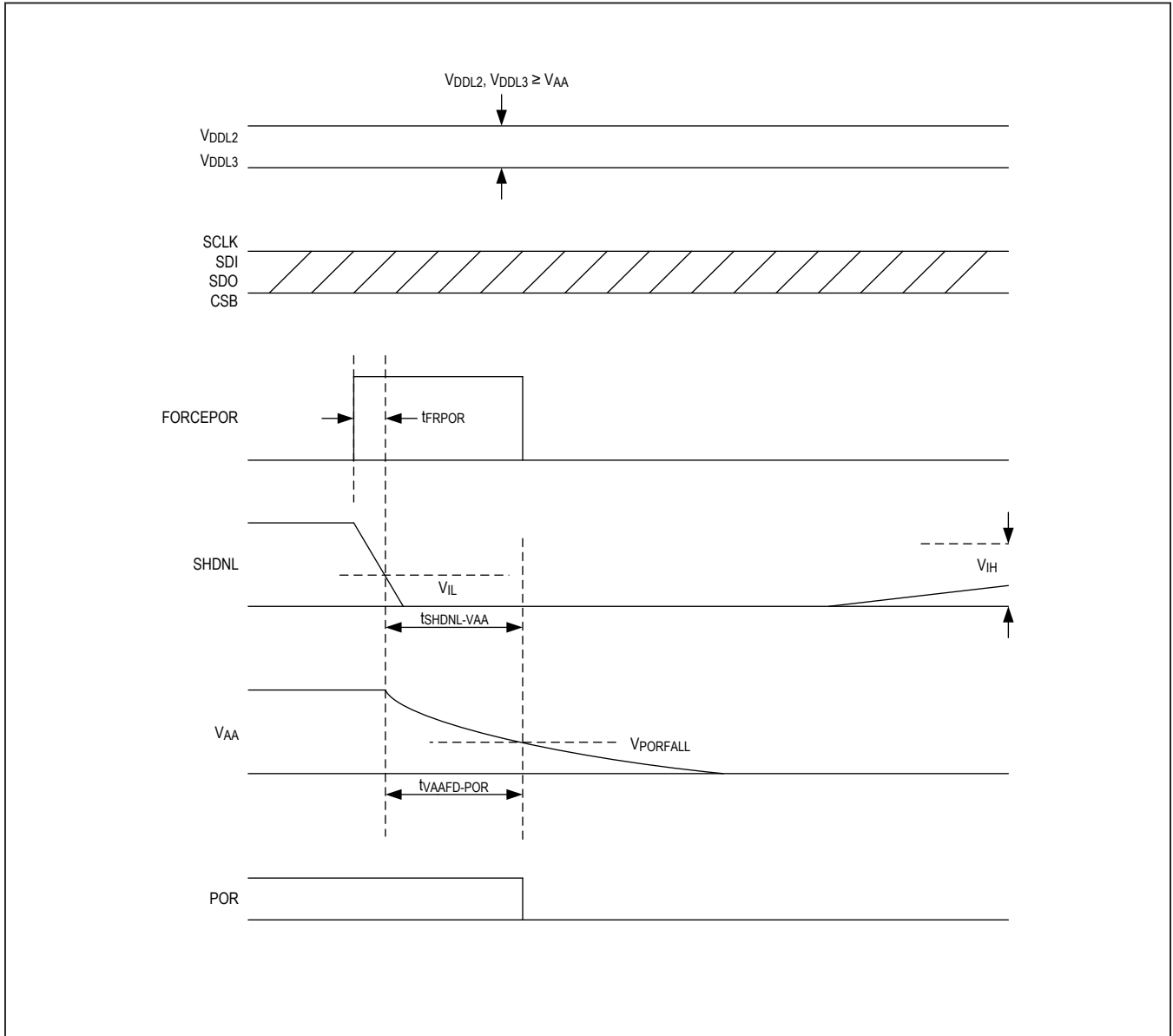

Figure 15. SPI Operation (Shutdown Timing)

Power-On and Shutdown Timing

The following diagrams provide details regarding the power-on control and shutdown timing as well as supply sequencing in a high-voltage daisy-chained system controlled by UART communication, as well as a low-voltage (48V) system with directed control over the SHDNL pin. It is important to note that the UART can also be used in low-voltage systems with single-ended communication,

as discussed in the *Single-Ended Rx Mode* section. In this case the directed control of the SHDNL pin remain the same.

Note: As shown in [Figure 14](#) and [Figure 15](#), the shutdown can also be controlled by writing the specific FORCEPOR bit. If SHDNL is actively driven, the application circuit should ensure there is no contention and this is driven below V_{IL_SHDNL} .

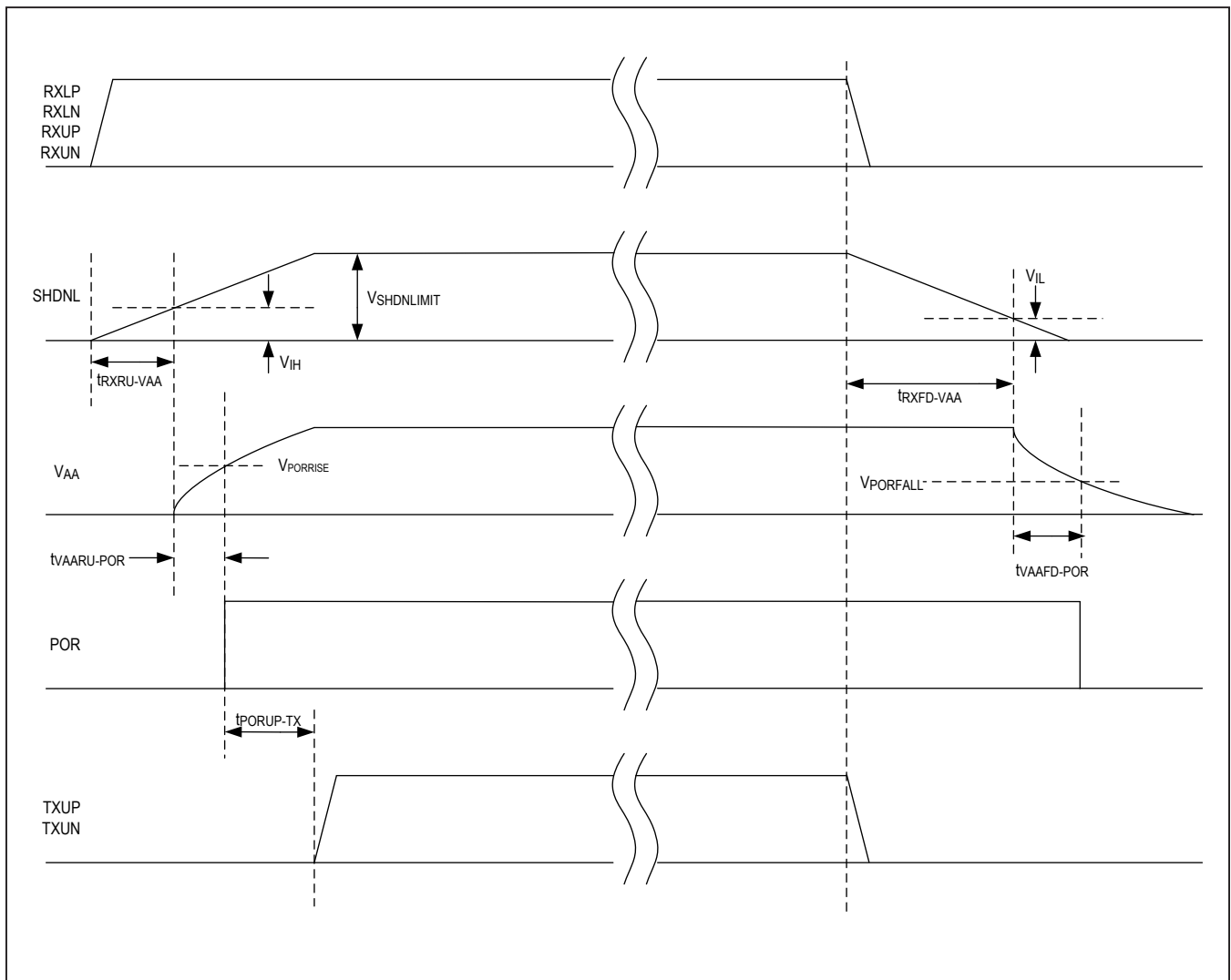

Figure 16. Power-On Timing (UART-Communication Control)

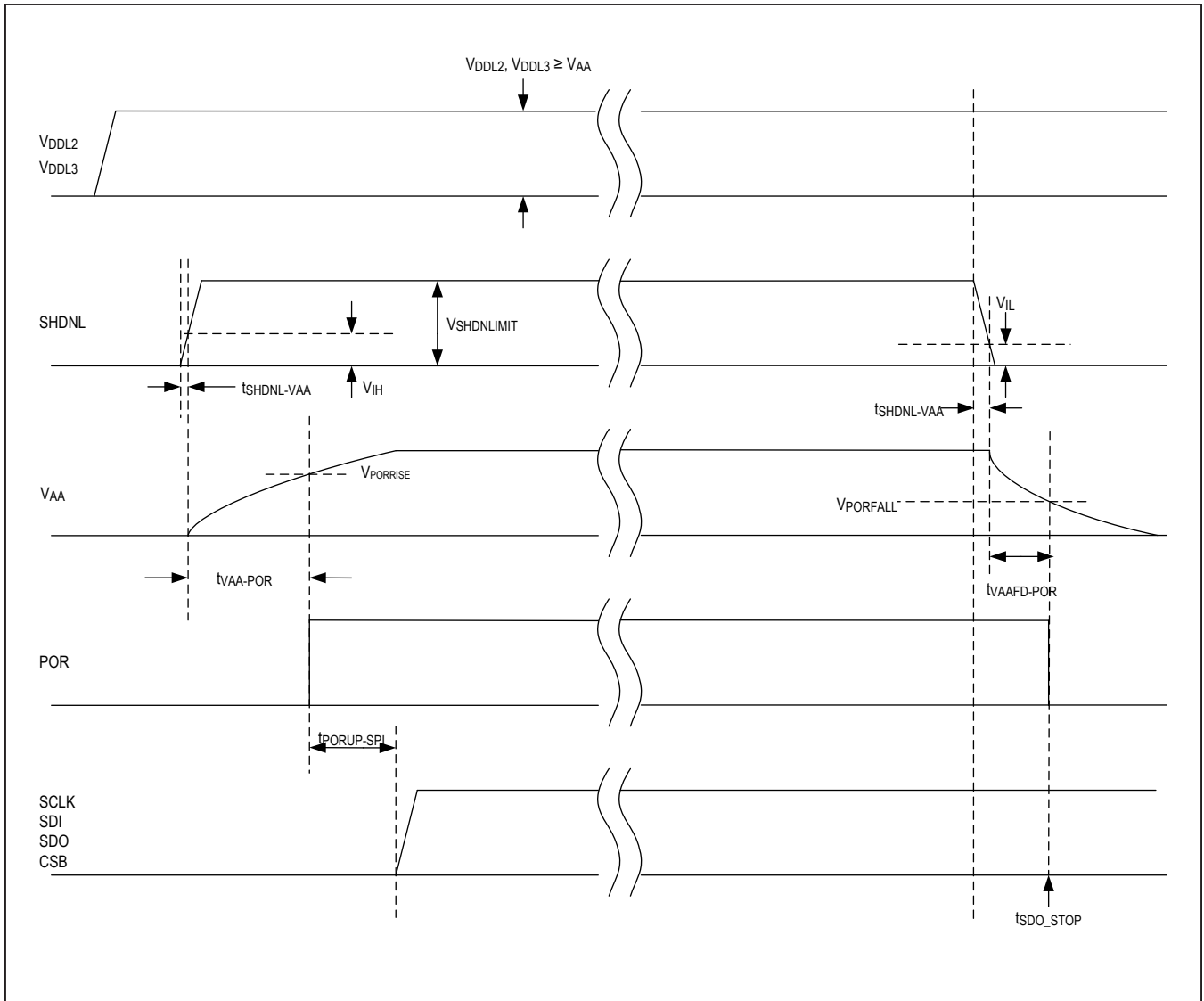

Figure 17. Power-On Shutdown Timing (SPI Directed Control)

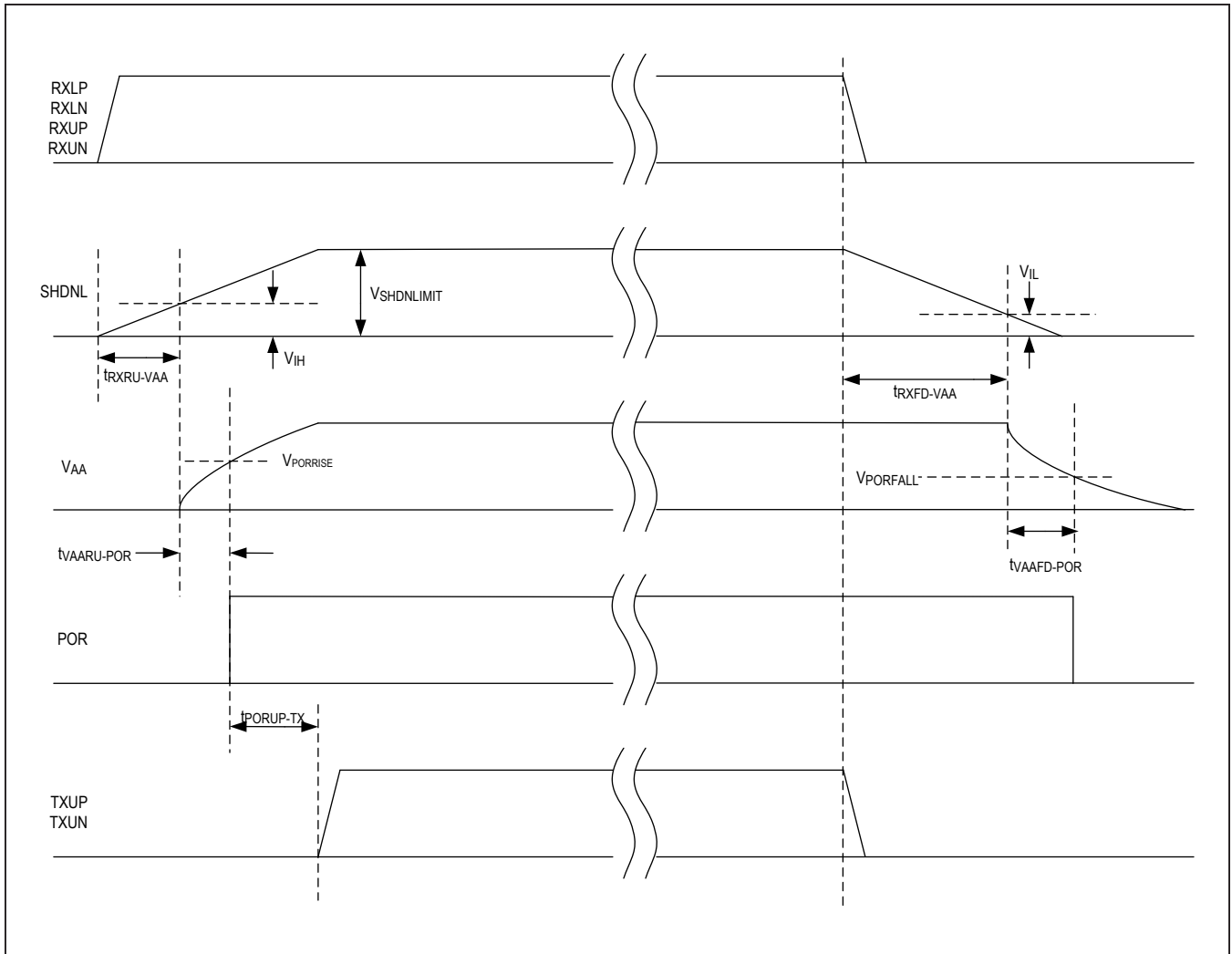

Figure 18. Power-On and Shutdown Timing (UART Control)

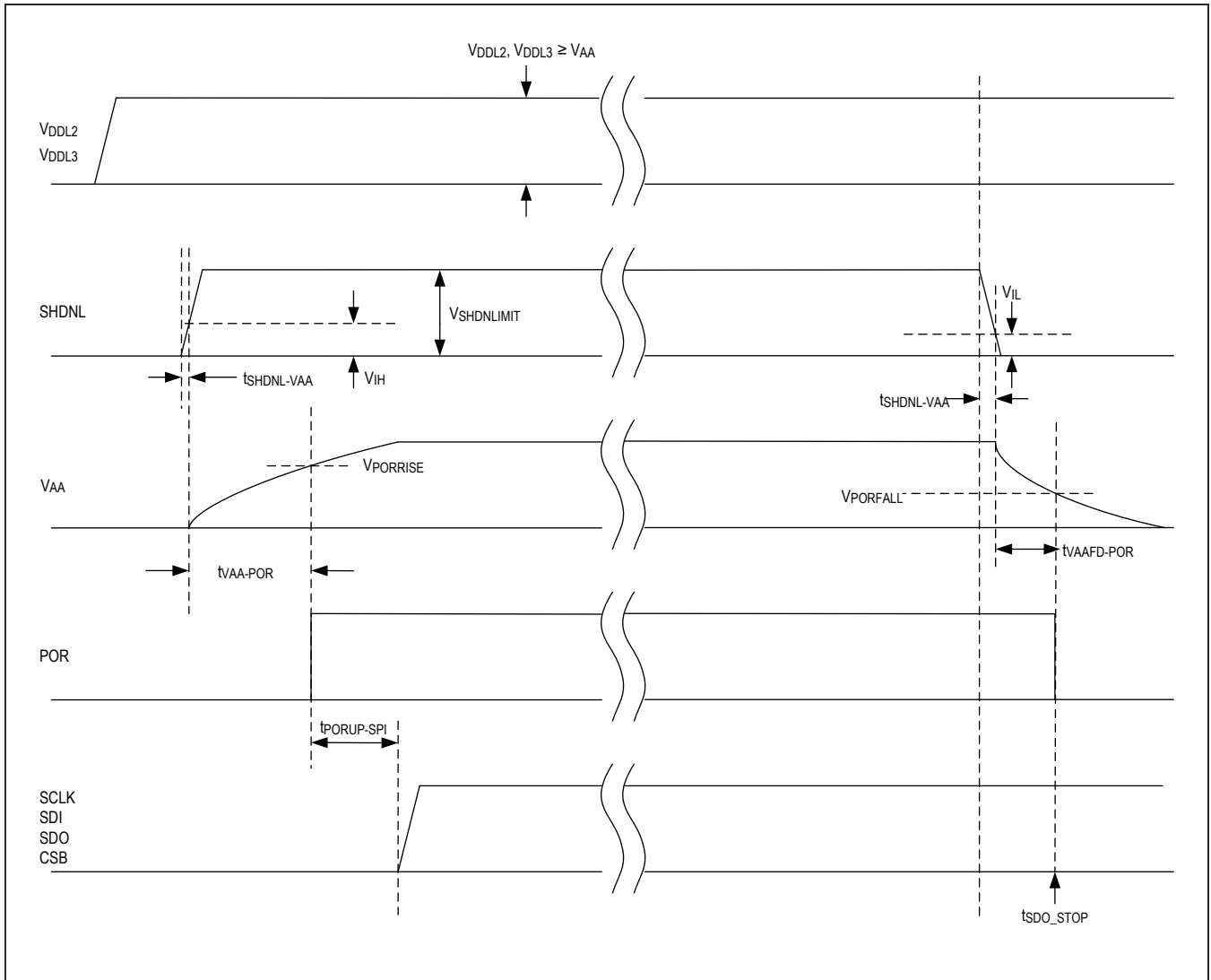

Figure 19. Power-On and Shutdown Timing (SPI Control)

Active Mode

The device enter acquisition mode upon receiving a SCAN command or during cell-balancing operation with UV threshold detection. The overall time spent in acquisition mode is determined by the settings defined by the SCANCTRL and ACQCFG registers. Once the acquisition is completed (signified by SCANDONE and DATARDY), the device enter the low power standby mode operation. During any point within acquisition mode, SHDNL is pulled below V_{IL_SHDNL} , T_{SHDNL} is exceeded, or V_{AA} transitions below the POR threshold, the device exit acquisition and enter shutdown mode.

Precision Internal Voltage References

The measurement system uses two precision, temperature-compensated voltage references. The references are completely internal to the device and do not require any external components. The primary voltage reference, or REF, is used to derive the linear regulator output voltage and to supply the ADC reference. An alternate, independent reference (ALTREF) can be used to verify the primary reference voltage as described in the Diagnostics section.

Scan Methods

The MAX17853 has two parallel measurements engines (ADC and Comparator) that are capable of providing three different acquisitions (ADC Acquisition, Comparator Acquisition, and Simultaneous ADC + Comparator Acquisition). The combination of both measurement block provides hardware redundancy to accelerate fault detection and ensure added system reliability.

All modes are able to process the cell and auxiliary temperature/auxiliary-voltage measurements and each have their own unique alert threshold settings to accelerate the communication of a system fault. Alert settings are described in further detail in the [Measurement Alerts](#) section.

ADC Input Range

The ADC supports unipolar and bipolar cell input acquisitions through the configuration settings of the

POLARITY[13:0] bits in the POLARITYCTRL register. In the unipolar configuration the input range is nominally 0V to 5V. In the bipolar configuration, the nominal input range is nominally -2.5V to 2.5V. Through combining the conversion data from the two scan configurations the input range can effectively be extended from -2.5V to 5V where any bipolar measurements over 2.3V should be supplemented with the unipolar measurements.

The flexibility to support both unipolar and bipolar conversions ensures that both cell measurements as well as bus-bar measurements are able to be simultaneously captured within the same acquisition which help optimize acquisition time and interface throughput.

Note: Conversions for some diagnostic modes automatically preconfigure the device to use either bipolar or unipolar mode regardless of the POLARITY_n bit value in the POLARITYCTRL register.

The ADC also supports both ratiometric and absolute acquisitions for the auxiliary inputs through the configuration setting of the AUXREFSEL[5:0] bits in the AUXREFCTRL register. Ratiometric acquisitions are primarily used for NTC based temperature measurements and support an input range of 0V to V_{AA} . Absolute acquisitions can be used for any on supplemental voltage measurement required by the application and supports an input range of 0V to V_{REF} . To ensure the highest accuracy for the application, the appropriate mode should be configured (it is not recommended to perform a ratiometric acquisition for an absolute measurement such as a supply voltage as the variability in the reference (V_{AA}) can introduce unwanted measurement error).

The auxiliary configuration supports simultaneous acquisition of both absolute and ratiometric measurements to help optimize acquisition time and interface throughput.

Note: In all ADC configurations, reduced linearity may occur near the zero-scale and full-scale limits. Refer to the [Electrical Characteristics](#) table for device accuracy specification.

Table 13. ADC Input Range

CELL INPUT VOLTAGE		AUX RATIO INPUT VOLTAGE	AUX ABSOLUTE INPUT VOLTAGE	CELLn[15:2] AUXn[15:2] (14 BITS)		CELLn[15:0] AUXn[15:0] (16 BITS)
BIPOLAR MODE	UNIPOLAR MODE			HEXADECIMAL	DECIMAL	
-2.5V	0V	0V	0V	0000h	0d	0000h
0V	2.5V	$V_{AA}/2$	$V_{REF}/2$	2000h	8192d	8000h
2.5V	5V	V_{AA}	V_{REF}	3FFFh	16383d	FFFCh

Comparator Input Range

The comparator supports a unipolar cell input range from 0V to 5V input through the configuration of the POLARITY[13:0] bit in the POLARITYCTRL registers. If the individual POLARITY bit is configured for a bipolar acquisition the comparator cell measurement be omitted from the scan.

The comparator also supports ratiometric and absolute acquisition for the auxiliary input that follows the same configuration as described in the ADC Input Range section. Ratiometric acquisitions support an input range of 0V to V_{AA} and absolute acquisitions supports an input range of 0V to V_{REF} .

Scan Configuration

The SCANCFG bits in the SCANCTRL register selects the acquisition that is to be performed. All available configurations are listed below.

- 1) ADC Acquisition
- 2) ADC and Comparator (ADC+COMP) Acquisition
- 3) Comparator Acquisition
- 4) Calibration
- 5) Balancing Switch Short
- 6) Balancing Switch Open
- 7) Cell Sense Open Odds
- 8) Cell Sense Open Evens

ADC, Comparator, and ADC+COMP acquisitions have programmable sample intervals through the configuration of the FOSR bit. This setting when coupled with the

OVSAMPL allows for specific frequency rejection at either 50Hz/100Hz or 60Hz/120Hz. If not configured, the user may specifically control the sample interval through the timing of the interface to support any desired post processing on the host controller.

Note: The Balance Switch and Cell Sense acquisitions immediately configure the internal balance switches once the SCANCFG bitfield is written. Refer to the BALSWS Diagnostic Section for details on the operation of this acquisition mode

ADC Configurations and Properties

ADC Polarity Configuration

Unipolar and bipolar measurements are supported within a single acquisitions to capture all cell and bus bar data without the need to reconfigure multiple scan configuration registers or perform multiple acquisitions. Cell polarity is configured using the POLARITYCTRL register where all cells are defaulted to unipolar measurements (POLARITY [13:0] = 0000h).

Bipolar cells are fault masked during BALSWDIAG ADC Measurement scans. MINMAXPOL determines whether Bipolar cells are included in MIN/MAXCELL and ALRTMSMTCH calculations.

Bipolar cell measurements are checked against BIPOVTH and BIPUVTH thresholds rather than OVTH and UVTH thresholds.

Bipolar cells are not included in Comparator Measurement scans, and ALRTCOMPOV/ALRTCOMPUV alerts are not evaluated.

Table 14. Comparator Input Range

CELL INPUT VOLTAGE	AUX RATIO INPUT VOLTAGE	AUX ABSOLUTE INPUT VOLTAGE	COMPOVTH, COMPUVTH, COMPAUXROVTH, COMPAUXRUVTH, COMPAUXAOTH, COMPAUXAUVTH (10 BITS)		COMPOVTH[15:0], COMPUVTH[15:0], COMPAUXROVTH[15:0], COMPAUXRUVTH[15:0], COMPAUXAOTH[15:0], COMPAUXAUVTH[15:0] (16 BITS)
			HEXADECIMAL	DECIMAL	
0V	0V	0V	000h	0d	0000h
2.5V	$V_{AA}/2$	$V_{REF}/2$	200h	512d	8000h
5V	V_{AA}	V_{REF}	3FFh	1024d	FFC0h

ADC Acquisition

ADC acquisitions can be configured for the {adc_blocks}. The acquisition is initiated by writing a logic one to the SCAN bit in the SCANCTRL register. This write acts as a strobe, and the SCAN bit content is automatically cleared reading back a logic zero is polled. In daisy-chained devices, acquisitions in either UART path (depending on the Master configuration) be delayed by the propagation delay, t_{PROP} , of the command packet through each device. The acquisition for device is signaled complete when SCANDONE bit is a logic one.

Note: If any additional write to the SCANCFG is issued prior to the SCANDONE bit being cleared this command be ignored.

Pyramid Mode Acquisition Sequence

The ADC acquisition process for Pyramid Mode (SCANMODE = 0) is outlined below:

- 1) Disable HV charge pump
- 2) VBLK conversion (first phase), if enabled
- 3) All enabled cell conversions (first phase), if enabled
 - a) ascending order (1 through 14)

- 4) All enabled cell conversions (second phase), if enabled
 - a) descending order (14 through 1)
- 5) VBLK conversion (second phase), if enabled
- 6) <End of Pyramid>
- 7) DIAG1 conversion (first phase), if enabled
- 8) DIAG1 conversion (second phase), if enabled
- 9) DIAG2 conversion (first phase), if enabled
- 10) DIAG2 conversion (second phase), if enabled
- 11) Auxiliary conversions, if enabled
- 12) Enable HV charge pump for recovery period unless
 - a) OVSAMPL = 000b (no oversampling) or
 - b) all oversample measurements are complete
- 13) Repeat steps 1 through 11 until all oversamples are done
- 14) Set SCANDONE bit

ADC Pyramid Mode Figures

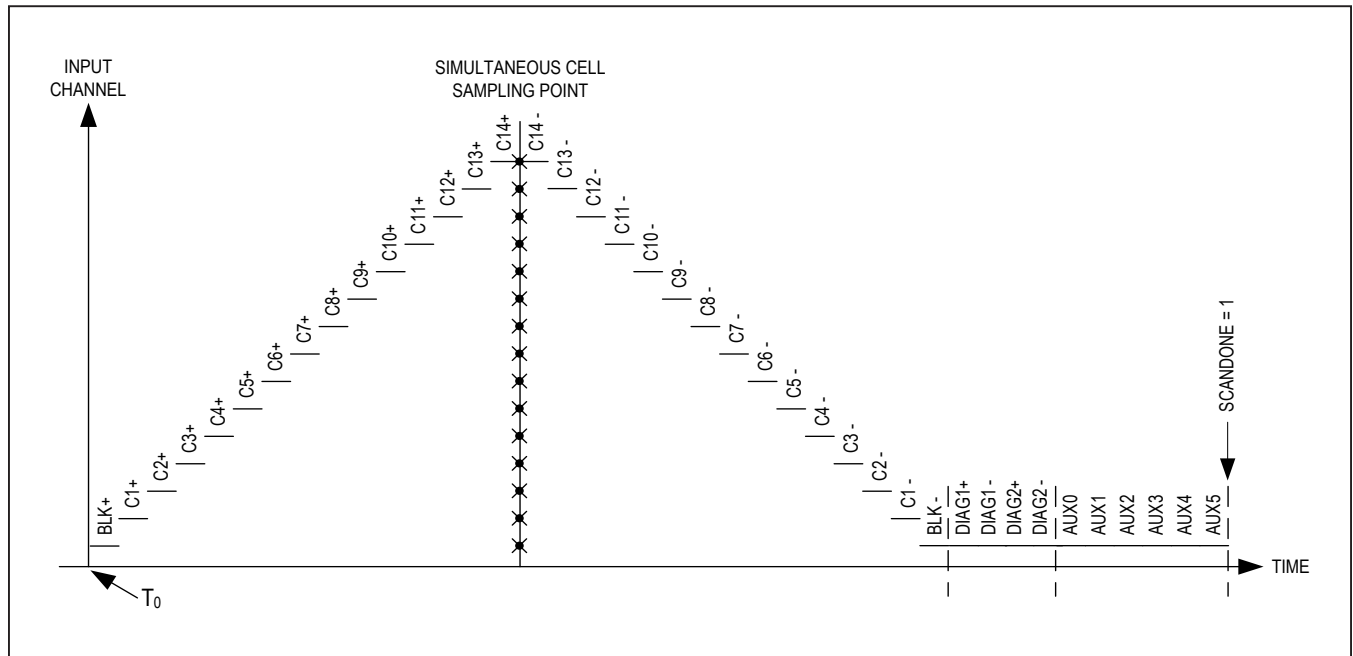

Figure 20. Acquisition (SCANCFG=0h, SCANMODE=0, OVSAMPL=0h, ALTMUXSEL=0, BLOCKEN=1, DIAGSEL1 > 0h, DIAGSEL2 > 0h, AUXEN=3Fh)

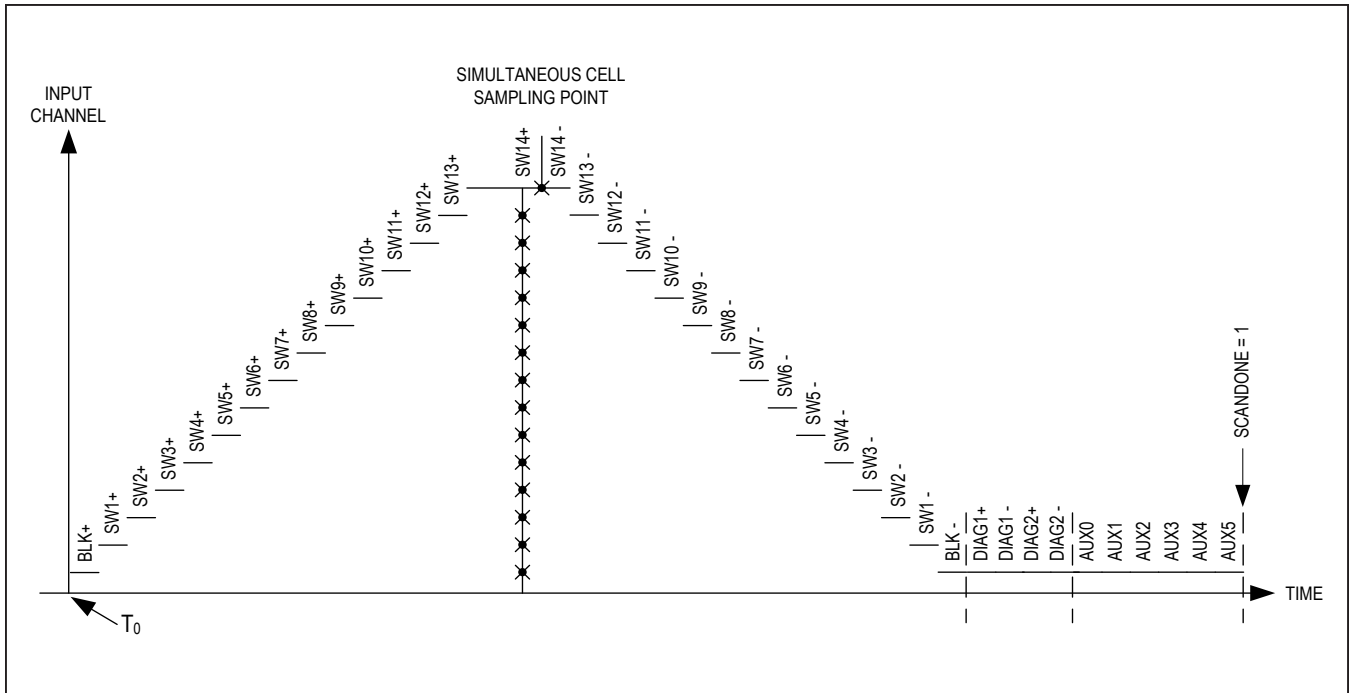

Figure 21. Acquisition (SCANCFG=0h, SCANMODE=0, OVSAMPL = 0h, TOPCELL1/2 = 14, ALTMUXSEL=1, BLOCKEN=1, DIAGSEL1 > 0h, DIAGSEL2 > 0h, AUXEN=3F)

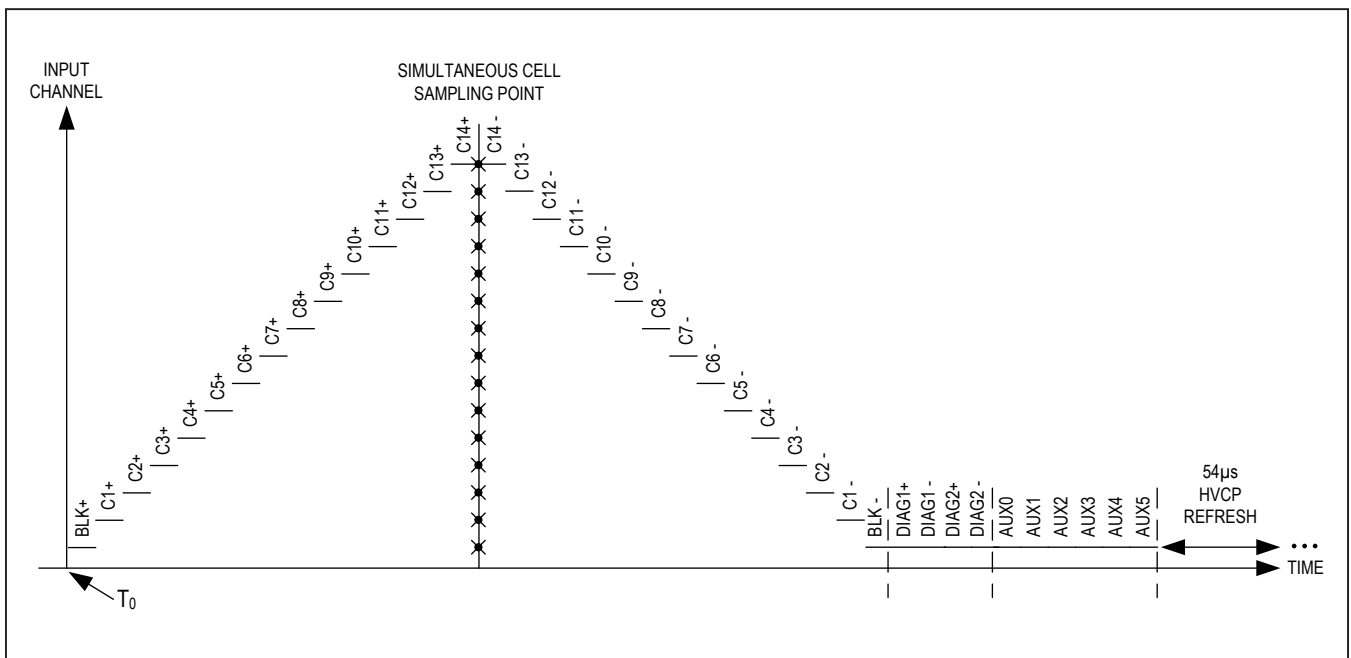

Figure 22. Acquisition - SCANCFG=0h, SCANMODE=0, OVSAMPL > 0h, ALTMUXSEL=0, BLOCKEN=1, DIAGSEL1 > 0h, DIAGSEL2 > 0h, AUXEN=3Fh

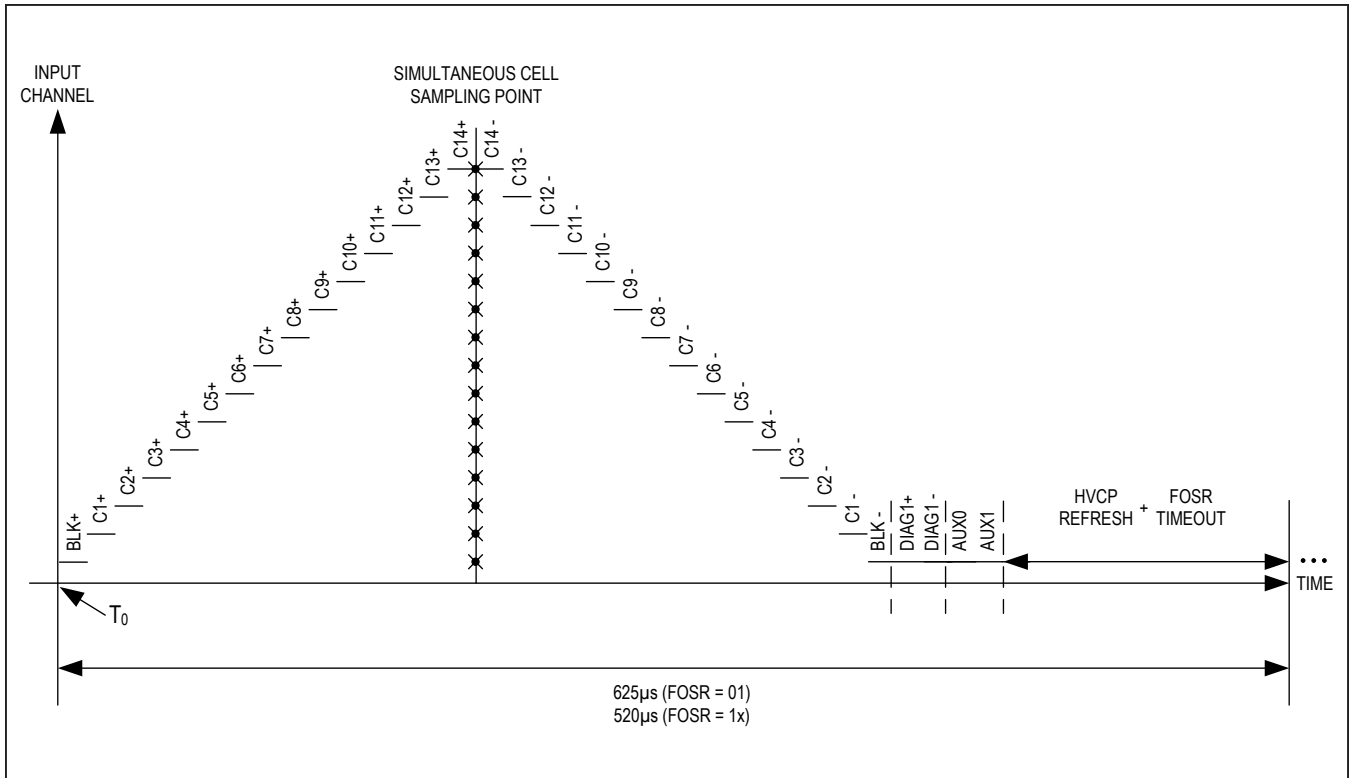

Figure 23. Acquisition (SCANCFG=0h, SCANMODE=0, OVSAMPL > 0h, ALTMUXSEL=0, BLOCKEN=1, DIAGSEL1 > 0h, AUXEN=03h, FOSR > 0h)

Pyramid Mode Acquisition Time

The total time for ADC Pyramid Mode acquisitions can be calculated by summing all the conditional process times as shown in following tables. There is one measurement cycle per oversample acquisition.

ADC Acquisition Timing (Pyramid Mode)

Table 15. ADC Pyramid Mode (SCANMODE = 0) Acquisition Time

PROCESS	TIME (μ s)	CONDITION	FREQUENCY
Initialization	15	Always	Once per Acquisition
AUXIN Settling (if enabled)	6 * AUXTIME[9:0]	THRMODE = Automatic Mode and FOSR = 1.6kHz, 1.92kHz Mode	Once per Acquisition
	6 * AUXTIME[9:0] - $t_{Initialization}$ - t_{VBLK} - $t_{Cell_Scan_Setup}$ - t_{Cell_Scan} - t_{Diag_Total}	THRMODE = Automatic Mode and FOSR = Free Run Mode	
VBLK Measurement (if enabled)	27.75	BLOCKEN = 1	Every Measurement Cycle
Cell Scan Setup	6.38	For any cell(s) enabled	
Cell Measurement	9 x y	For y = # of enabled cell inputs	
DIAG1 Measurement AND/OR DIAG2 Measurement (if enabled)	32.44	Die Temperature Diagnostic	
	23.81	V _{AA} Diagnostic	
	8.44	Comp Signal Path Diagnostic	
	24.28	Cell Gain Calibration Diagnostic	
	86.44	V _{ALTRF} Diagnostic	
	19.5	DAC 3/4, DAC 1/4	
AUXIN Measurement (if enabled)	5.44 * x	For x = # of enabled AUXIN Inputs	
HV Recovery (if oversampling enabled)	57 * (z-1)	For z = # of oversamples	Every Measurement Cycle Except Last
ADCZSFS Diagnostic (if enabled)	11.2	ADCZSFSEN = 1	End of Acquisition
COMPACC Diagnostic (if enabled)	13.5	COMPACCEN = 1	End of Acquisition

Ramp-Mode Acquisition Sequence

The ADC acquisition process for Ramp Mode (SCANMODE = 0) is outlined below:

- 1) Disable HV charge pump
- 2) VBLK conversion (first phase), if enabled
- 3) All enabled cell conversions (1 through 14), if enabled
- 4) VBLK conversion (second phase), if enabled
- 5) <End of Ramp>
- 6) DIAG1 conversion, if enabled
- 7) DIAG2 conversion, if enabled
- 8) Auxiliary conversions, if enabled
- 9) Enable HV charge pump for recovery period unless
 - a) OVSAMPL = 000b (no oversampling) or
 - b) all oversample measurements are complete
- 10) Repeat steps 1 through 7 until all oversamples are done
- 11) Set SCANDONE bit

ADC Ramp-Mode Figures

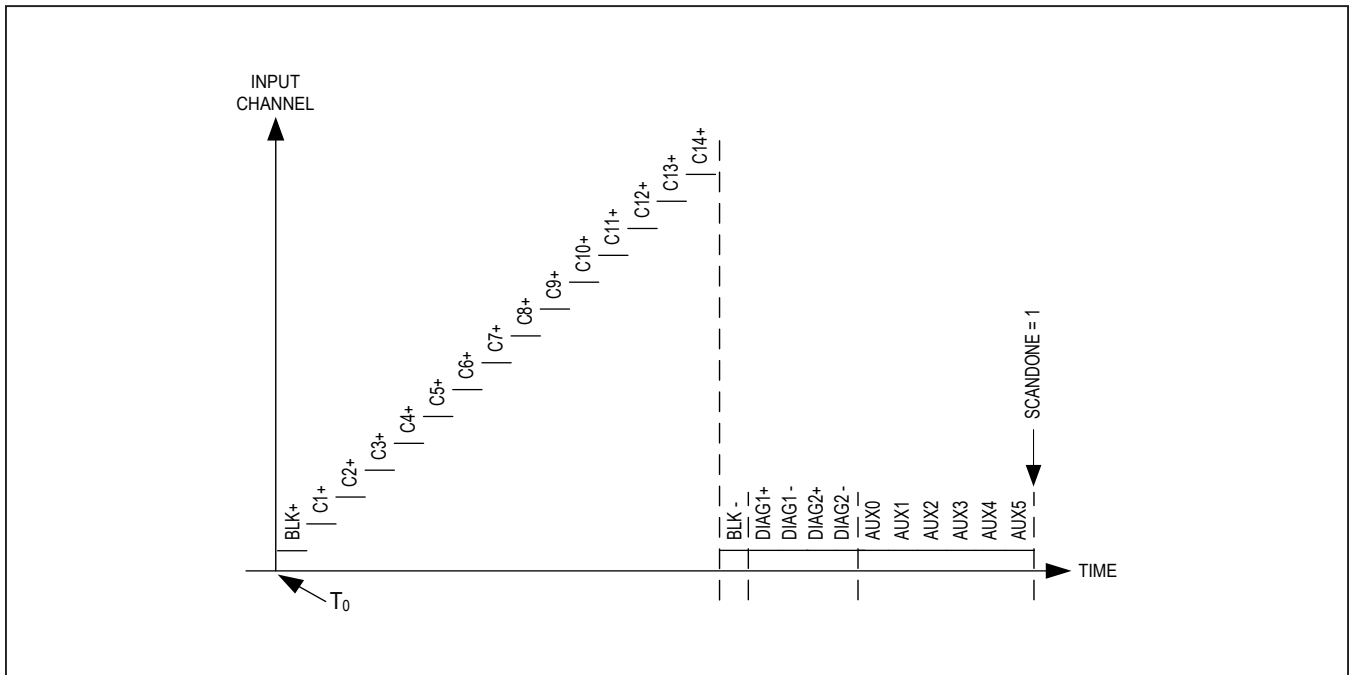

Figure 24. Acquisition (SCANCFG=0h, SCANMODE=1, OVSAMPL=0h, ALTMUXSEL=0, BLOCKEN=1, DIAGSEL1 > 0h, DIAGSEL2 > 0h, AUXEN=3Fh)

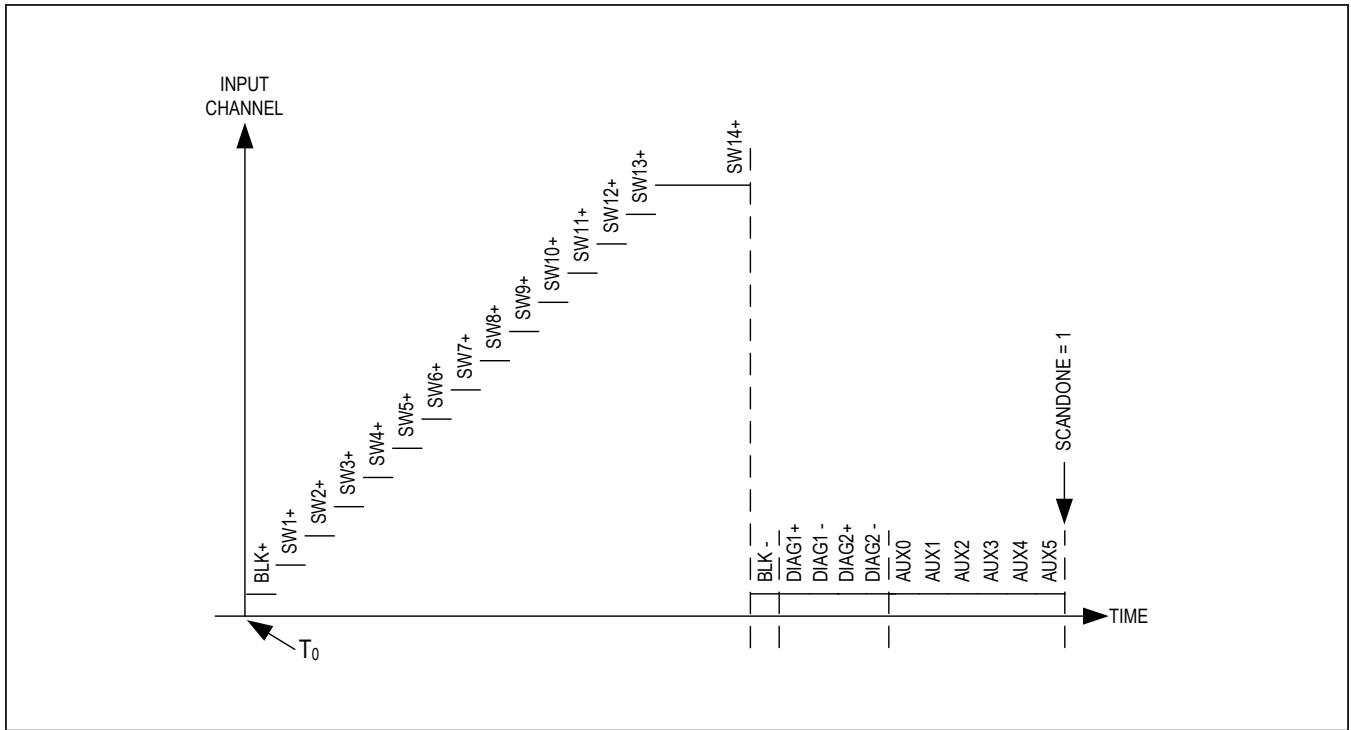

Figure 25. Acquisition (SCANCFG=0h, SCANMODE=1, OVSAMPL = 0h, TOPCELL1/2=14, ALTMUXSEL=1, BLOCKEN=1, DIAGSEL1 > 0h, DIAGSEL2 > 0h, AUXEN=3Fh)

Ramp-Mode Acquisition Time

The total time for ADC ramp-mode acquisitions can be calculated by summing all the conditional process times, as shown in [Table 16](#). There is one measurement cycle per oversample acquisition.

ADC Acquisition Timing (Ramp Mode)**Table 16. ADC Ramp Mode (SCANMODE = 1) Acquisition Time**

PROCESS	TIME (μ s)	CONDITION	FREQUENCY
Initialization	15	Always	Once Per Acquisition
AUXIN Settling (if enabled)	$6 * \text{AUXTIME}[9:0]$	THRMMODE = Automatic mode, FOSR = 1.6kHz, 1.92kHz mode	Once Per Acquisition
	$6 * \text{AUXTIME}[9:0]$ - $t_{\text{Initialization}}$ - t_{VBLK} - $t_{\text{Cell_Scan_Setup}}$ - $t_{\text{Cell_Scan}}$ - $t_{\text{Diag_Total}}$	THRMMODE = Automatic mode FOSR = Free-run mode	
VBLK Measurement (if enabled)	27.75	BLOCKEN=1	Every Measurement Cycle
Cell Scan Setup	3.19	For any cell(s) enabled	
Cell Measurement	$4.5 * y$	For $y = \#$ of enabled cell inputs	
DIAG1 Measurement and/or DIAG2 Measurement (if enabled)	32.44	Die Temperature Diagnostic	
	23.81	V_{AA} Diagnostic	
	8.44	Comp Signal-Path Diagnostic	
	24.44	Cell-Gain Calibration Diagnostic	
	86.44	V_{ALTREF} Diagnostic	
	19.5	DAC 3/4, DAC 1/4	
AUXIN Measurement (if enabled)	$5.44 * x$	For $x = \#$ of enabled AUXIN Inputs	
HV Recovery (if oversampling enabled)	$57 * (z-1)$	For $z = \#$ of oversamples	Every Measurement Cycle Except Last
ADCZSFS Diagnostic (if enabled)	11.2	ADCZSFSSEN=1	End of Acquisition
COMPACC Diagnostic (if enabled)	13.5	COMPACCEN=1	End of Acquisition

ADC Acquisition Time Example

Table 17 provides an example of common configuration and the associated acquisition time that can be achieved.

Table 17. ADC Acquisition Time Examples (with AUXTIME[9:0] = 000h)

ENABLED MEASUREMENTS	NO OVERSAMPLING (OVSAMPL[2:0] = 0h)		8x OVERSAMPLING (OVSAMPL[2:0] = 2h)		16x OVERSAMPLING (OVSAMPL[2:0] = 3h)	
	Pyramid Scan	Ramp Scan	Pyramid Scan	Ramp Scan	Pyramid Scan	Ramp Scan
14 Cells	148.3µs	82.1µs	1480.5µs	951µs	3003.1µs	1944µs
14 Cells, VBLK	175.7µs	109.5µs	1699.5µs	1170µs	3441.1µs	2382µs
14 Cells, 6 Aux	181µs	114.8µs	1741.7µs	1212.1µs	3525.3µs	2466.3µs
14 cells, VBLK, 6 Aux	208.3µs	142.1µs	1960.7µs	1431.1µs	3963.3µs	2904.3µs
14 cells, VBLK, Die Temp DIAG, 6 Aux	240.6µs	174.4µs	2218.7µs	1689.1µs	4479.3µs	3420.3µs

Comparator Configuration and Properties

Comparator-Scan Properties

The comparator acquisition can be configured for unipolar Cell measurements and Auxiliary measurements. If a cell input is configured for bipolar operation in the POLARITYCTRL register, the comparator measurement is idle for this acquisition period and the associated alert reporting in the ALRTCOMPOVREG and ALRTCOMPUVREG register not be updated. If acquisition time is of critical importance for a comparator scan, it is recommended to disable bipolar inputs in the MEASUREEN1 register to prior to issuing a SCAN as this omit these measurements from the acquisition.

The SCANMODE bit configuration also does not apply to the comparator acquisition and the comparator operate only on the inputs indicated by the MEASUREEN1 and ALRTOVEN, ALRTUVEN registers. This is illustrated in the comparator acquisition process defined below.

Comparator Acquisition

The acquisition is initiated by writing a logic one to the SCAN bit in the SCANCTRL register. This write acts as a strobe, and the SCAN bit content is automatically cleared reading back a logic zero if polled. In daisy-chained devices, acquisitions in either UART path (depending on the Master configuration) be delayed by the propagation delay, t_{PROP} , of the command packet through each device. The acquisition for device is signaled complete when SCANDONE bit is a logic one.

Note: If any additional write to the SCANCFG is issued prior to the SCANDONE bit being cleared this command be ignored.

Comparator-Acquisition Process

- 1) Disable HV charge pump
- 2) Perform overvoltage conversion on all enabled Cell Inputs (MEASUREEN1) against COMPOVTH threshold
 - a) ascending order (1 through 14)
- 3) Update ALRTCOMPOV Register (MEASUREEN1 & ALRTOVEN)
- 4) Perform undervoltage conversion on all enabled Cell Inputs (MEASUREEN1) against COMPUVTH threshold
 - b) descending order (14 through 1)
- 5) Update ALRTCOMPUV Register (MEASUREEN1 and ALRTUVEN)
- 6) Perform overvoltage conversion on all enabled Auxiliary Inputs (MEASUREEN2) against COMPAUXOVTH
 - c) ascending order (0 through 5)
- 7) Update ALRTCOMPAUXOV Register (MEASUREEN2 and ALRTAUXOVEN)
- 8) Perform undervoltage conversion on all enabled Auxiliary Inputs (MEASUREEN2) against COMPAUXUVTH
 - d) ascending order (0 through 5)
- 9) Update ALRTCOMPAUXUV Register (MEASUREEN2 and ALRTAUXUVEN)
- 10) HV charge-pump refresh
- 11) Repeat steps 2-6 until all oversamples complete
- 12) Compare results against comparator thresholds and update alert status
- 13) Enable HV Charge Pump

Note: Comparator results are only available when the corresponding OV/UV alerts are enabled.

Comparator Thresholds

The comparator cell measurements and auxiliary measurements can be programmed with OV and UV thresholds that are independent of the ADC OV and UV thresholds. However, all cell measurements share the same threshold settings as defined by the COMPOVTH and COMPUVTH registers. Additionally, all ratiometric auxiliary measurements share the same threshold settings as defined by the COMPAUXROVTH and COMPAUXRUVTH registers and all absolute auxiliary measurements share the same threshold settings as defined by the COMPAUXAOVTH and COMPAUXAUVTH registers.

As defined in the Comparator Input Range section, each threshold register is programmable up to 10 bits allowing for 4.9mV, 3.2mV, and 2.2mV of adjustable resolution on the cell, ratiometric auxiliary, and absolute auxiliary

measurements respectively. **Note:** for the auxiliary inputs since the full scale is dependent on V_{AA} this may have an impact on the resolution of the comparator over loading and temperature conditions.

If the pin configuration for the auxiliary inputs is set to GPIO mode, both ALRTAUXOVEN and ALRTAUXUVEN are disabled (logic 0).

Comparator Acquisition Time

The total time for Comparator acquisitions can be calculated by summing all the conditional process times (see [Table 18](#)). There is one measurement cycle per oversample acquisition.

Comparator Acquisition Timing Example

[Table 18](#) provides an example of common configuration and the associated acquisition time that can be achieved

Table 18. Comparator Acquisition Time

PROCESS	TIME (μ s)	CONDITION	FREQUENCY
Initialization	15	Always	Once per Acquisition
AUXIN Settling (if enabled)	$6 * \text{AUXTIME}[9:0]$	THRMMODE = Automatic mode and FOSR = 1.6kHz, 1.92kHz mode	Once per Acquisition
	$6 * \text{AUXTIME}[9:0]$ - $t_{\text{Initialization}}$ - t_{VBLK} - $t_{\text{Cell_Scan_Setup}}$ - $t_{\text{Cell_Scan}}$ - $t_{\text{Diag_Total}}$	THRMMODE = Automatic mode and FOSR = Free-Run mode	
Cell Scan Setup	6.38	For any cell(s) enabled	Every Measurement Cycle
Cell Measurement	$12 * y$	For $y = \#$ of enabled cell inputs	
AUXIN Measurement (if enabled)	$12.56 * x$	For $x = \#$ of enabled AUXIN Inputs	
HV Recovery (if oversampling enabled)	$57 * (z-1)$	For $z = \#$ of oversamples	Every Measurement Cycle Except Last
COMPACC Diagnostic (if enabled)	13.5	COMPACCEN=1	End of Acquisition

Table 19. Comparator Acquisition-Time Examples (with $\text{AUXTIME}[9:0] = 000h$)

ENABLED MEASUREMENTS	NO OVERSAMPLING (OVSAMPL[2:0] = 0h)	8x OVERSAMPLING (OVSAMPL[2:0] = 2h)	16x OVERSAMPLING (OVSAMPL[2:0] = 3h)
14 Cells	190.3 μ s	1816.5 μ s	3675.1 μ s
14 Cells, 6 Aux	265.7 μ s	2419.4 μ s	4880.8 μ s

Comparator Scan Figures

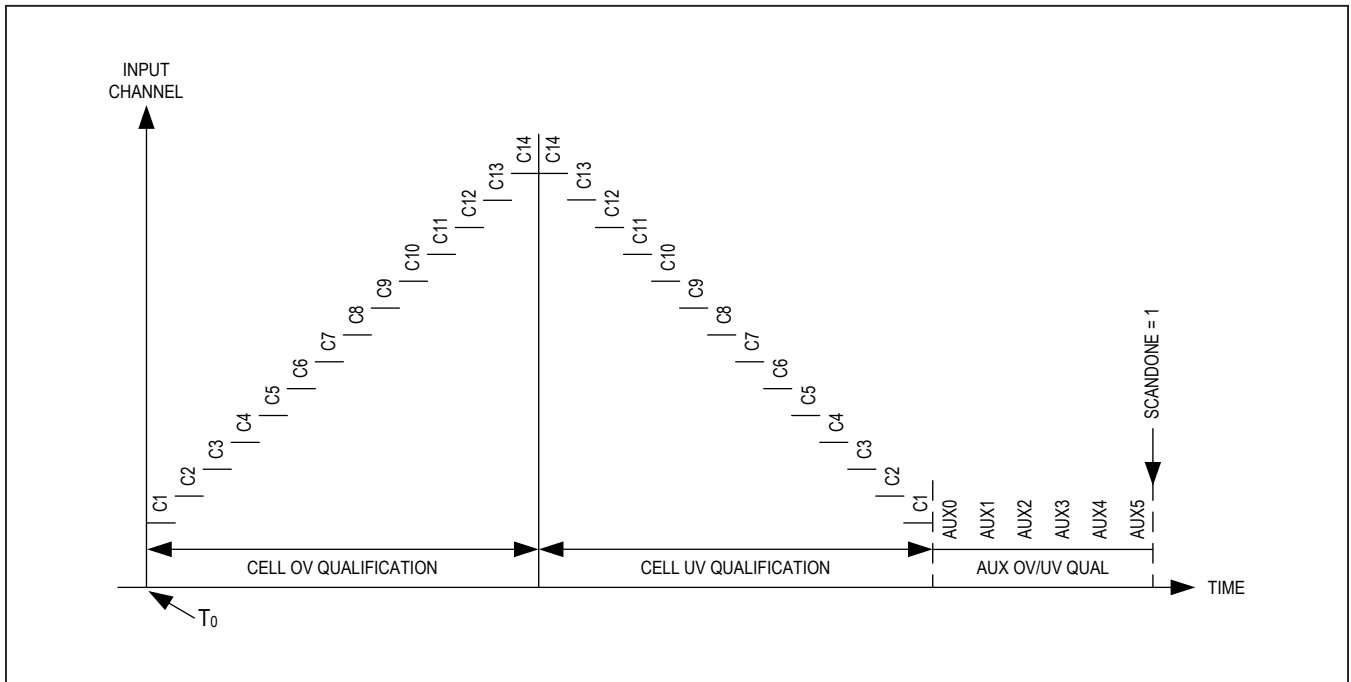

Figure 26. Comparator Single-Scan Mode

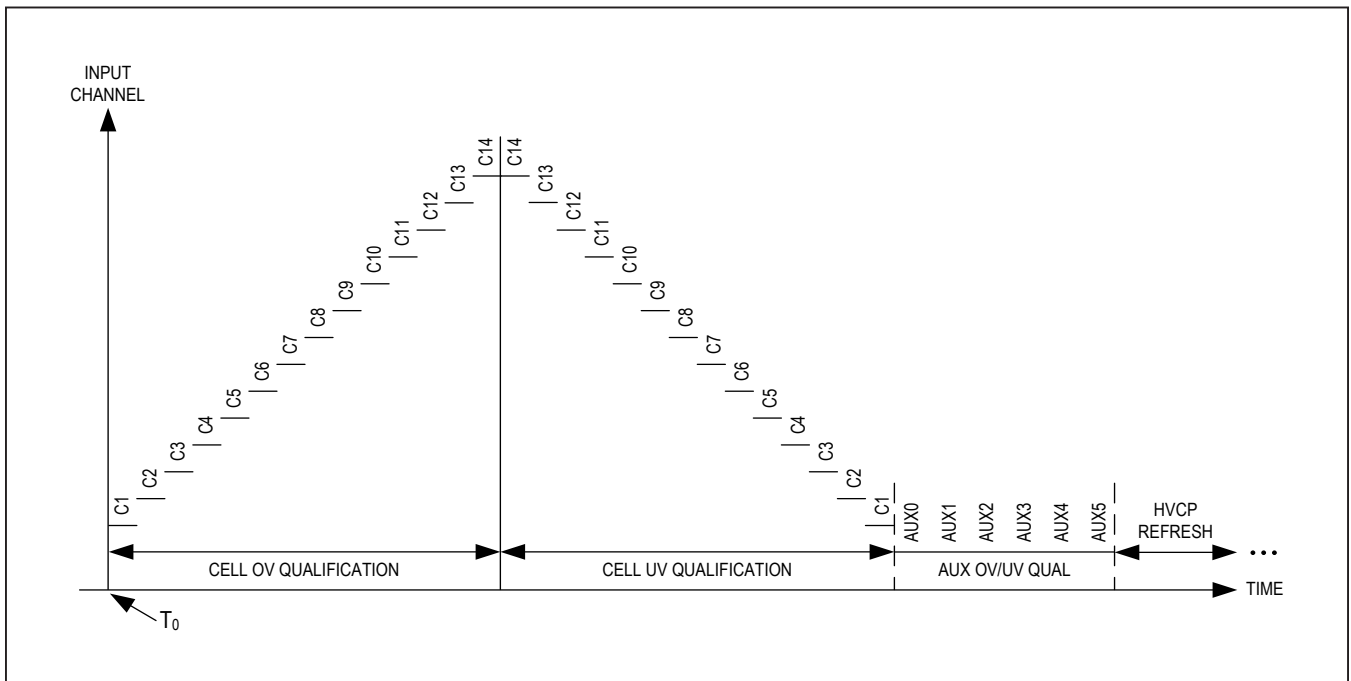

Figure 27. Comparator Single-Scan with Oversampling

ADC+COMP Configuration and Properties

ADC+COMP Scan Mode

ADC+COMP acquisitions can be applied to the Cell, Auxiliary, Block, and Diagnostics measurements. Each measurement engine (ADC or Comparator) retain the functionality discussed previously with additional clarification detailed below.

The comparator acquisition is applied to the unipolar Cell and Auxiliary inputs and be idle during bipolar Cell, Block, and Diagnostics measurements. OV and UV alerts for the the cell path, (OVALRTEN and UVALERTEN) and Auxiliary path (AUXOVALRTEN and AUXUVALRTEN) are

applied to both ADC and comparator with each capable of setting it unique threshold. If any OV or UV Alert is disabled the ADC measurement still occurs, however the comparator is idle during this portion of the acquisition.

In ADC+COMP scan mode, the ADC acquisition only operates in pyramid mode and the SCANMODE bit is ignored.

ADC+COMP Acquisition Time

The total time for ADC+COMP acquisitions can be calculated by summing all the conditional process times as shown in following tables. There is one measurement cycle per oversample acquisition

Table 20. ADC+COMP Acquisition Time

PROCESS	TIME (μ s)	CONDITION	FREQUENCY
Initialization	15	Always	Once per Acquisition
AUXIN Settling (if enabled)	6 * AUXTIME[9:0]	THRMMODE = Automatic mode and FOSR = 1.6kHz, 1.92kHz mode	Once per Acquisition
	6 * AUXTIME[9:0] - $t_{Initialization}$ - t_{VBLK} - $t_{Cell_Scan_Setup}$ - t_{Cell_Scan} - t_{Diag_Total}	THRMMODE = Automatic mode and FOSR = Free Run Mode	
VBLK Measurement (if enabled)	27.75	BLOCKEN=1	Every Measurement Cycle
Cell Scan Setup	6.38	For any cell(s) enabled	
Cell Measurement	12 * y	For y = # of enabled cell inputs	
DIAG1 Measurement AND/OR DIAG2 Measurement (if enabled)	32.44	Die Temperature Diagnostic	
	23.81	V _{AA} Diagnostic	
	8.44	Comp Signal Path Diagnostic	
	24.44	Cell Gain Calibration Diagnostic	
	86.44	V _{ALTREF} Diagnostic	
	19.50	DAC 3/4, DAC 1/4	
AUXIN Measurement (if enabled)	5.44	All Other Diagnostics	
AUXIN Measurement (if enabled)	12.56 * x	For x = # of enabled AUXIN Inputs	Every Measurement Cycle Except Last
HV Recovery (if oversampling enabled)	57 * (z-1)	For z = # of oversamples	
ADCZSFS Diagnostic (if enabled)	11.2	ADCZSFSEN=1	End of Acquisition
COMPACC Diagnostic (if enabled)	13.5	COMPACCEN=1	End of Acquisition

ADC+COMP Acquisition Time Example

Table 21 provides examples of common configuration and the associated acquisition time that can be achieved.

Table 21. ADC+COMP Acquisition Time Examples (with AUXTIME[9:0] = 000h)

ENABLED MEASUREMENTS	NO OVERSAMPLING (OVSAMPL[2:0] = 0h)	8x OVERSAMPLING (OVSAMPL[2:0] = 2h)	16x OVERSAMPLING (OVSAMPL[2:0] = 3h)
14 Cells	187.1µs	1791µs	3624µs
14 Cells, VBLK	214.5µs	2010µs	4062µs
14 Cells, 6 Aux	262.5µs	2393.9µs	4829.8µs
14 Cells, VBLK, 6 Aux	289.9µs	2612.9µs	5267.8µs
14 Cells, VBLK, Die Temp DIAG, 6 Aux	322.1µs	2870.9µs	5783.8µs

ADC+COMP Scan Figures

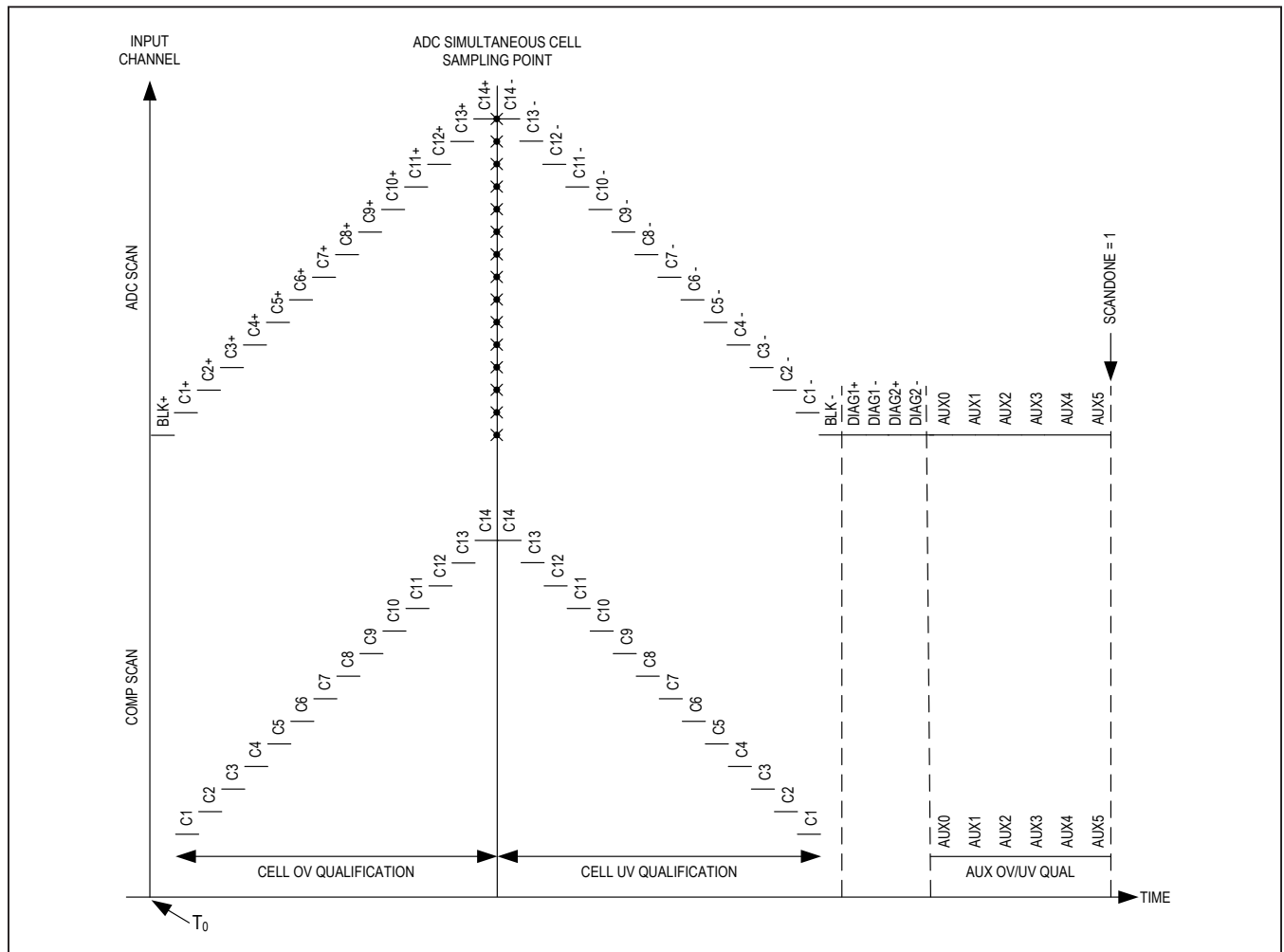

Figure 28. Simultaneous ADC+COMP Scan Mode

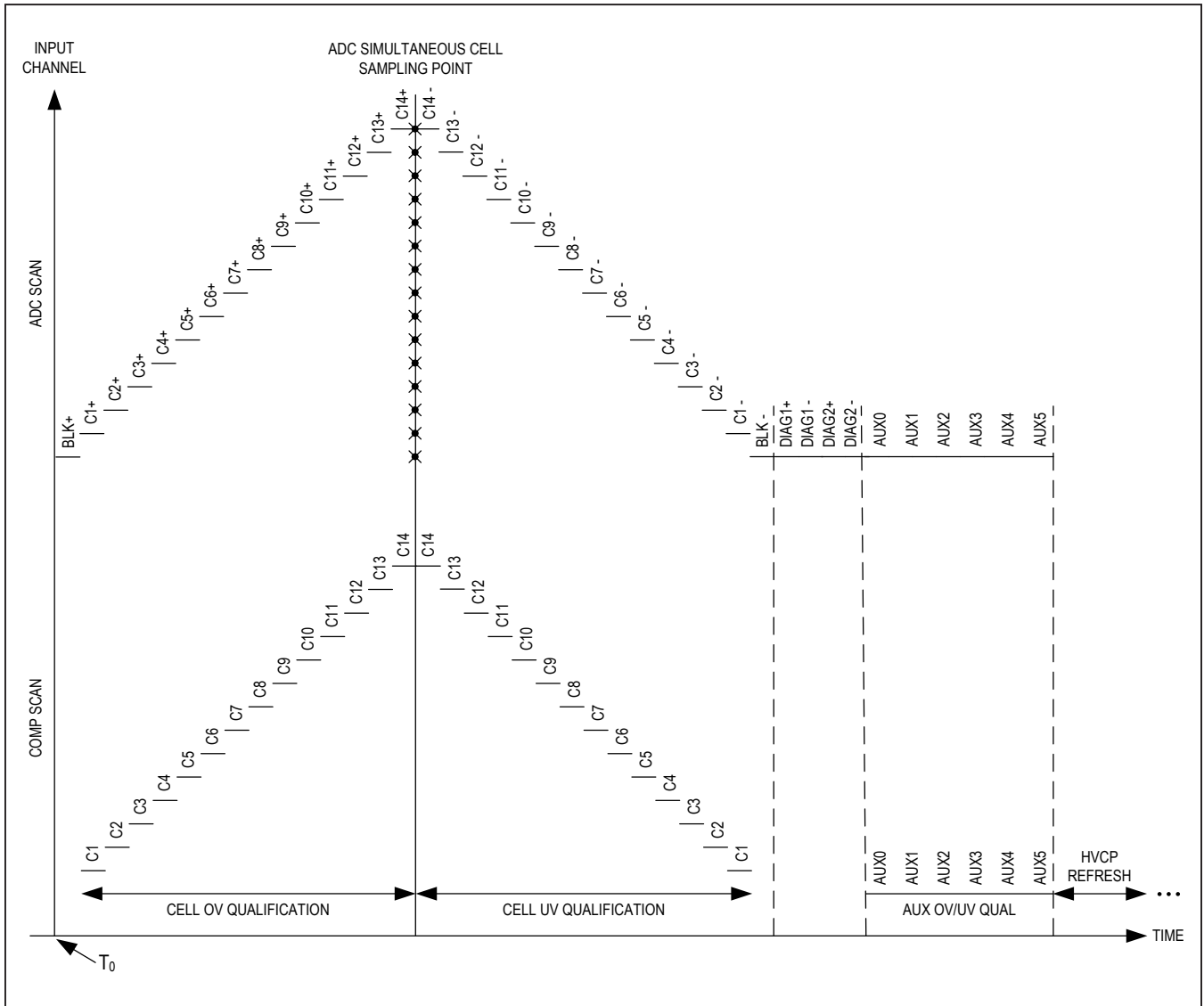

Figure 29. Simultaneous ADC+COMP Scan With Oversampling

On-Demand Calibration

The MAX17853 supports an integrated "On-Demand" calibration procedure which can be commanded by the user to improve the internal measurement accuracy from inaccuracies of the internal signal chain. It should however be noted that the calibration process not correct for inaccuracies within the external application components. The calibrated accuracy are described within the measurement accuracy section of the electrical characteristics.

For a valid "On-Demand" calibration, a calibration acquisition must be commanded using the SCANCFG bits of the SCANCTRL register. The calibration acquisition automatically configures the internal calibration sources and performs ADC acquisitions to calculate and store calibration coefficients for the Cell Inputs, Auxiliary Inputs, and Block Input. The completion of the calibration acquisition be signaled by the issuance of the SCANDONE bit like any other acquisition. Any commands that are sent before the calibration acquisition is completed be ignored but still propagate through the daisy-chain.

The calibration time is 3.75ms.

Note: The calibration acquisition is independent of the Scan Control Registers and Scan Setting Registers (POLARITYCTRL, SCANCTRL, ACQCFG) .

The ADCCALEN bit must be set for the calibration coefficients to be applied to the measurement results. If ADCCALEN disabled, even with the successful completion of a calibration acquisition, the measurement results not have the calibration coefficients applied.

Note: The "On-Demand" calibration is independent of the factory calibration. In the event that the "On-Demand" calibration is applied, the device retain its factory calibration setting. The factory calibration setting can never be overwritten and can be verified using the ROM CRC diagnostic in the Diagnostics section. See ADC Scan Properties for details on using calibration to maintain Ramp Mode accuracy over DCIN voltage range; factory calibration defaults are programmed using a 50V DCIN voltage.

[Table 22](#) indicates which calibration alerts are associated to the various measurement path

Table 22. Measurement Path Calibration Alerts

MEASUREMENT PATH	CALIBRATION ALERTS
Cell Input - Pyramid (SCANMODE = 0b)	ALRTCALGAINP, ALRTCALOSADC
Cell Input - Ramp (SCANMODE = 1b)	ALRTCALGAINR, ALRTCALOSR
Auxiliary Input - Absolute (REFSEL = 1b)	ALRTCALOSADC
Auxiliary Input - Ratio metric (REFSEL = 0b)	ALRTCALOSTHRM
Block Input	ALRTCALOSADC
CSA Input	ALRTCALOSADC

The "On-Demand" calibration adjustments can be verified by using the Cell Calibration and Offset Calibration commands in the DIAGSEL1 and DIAGSEL2 bits. See the Diagnostics section for further details.

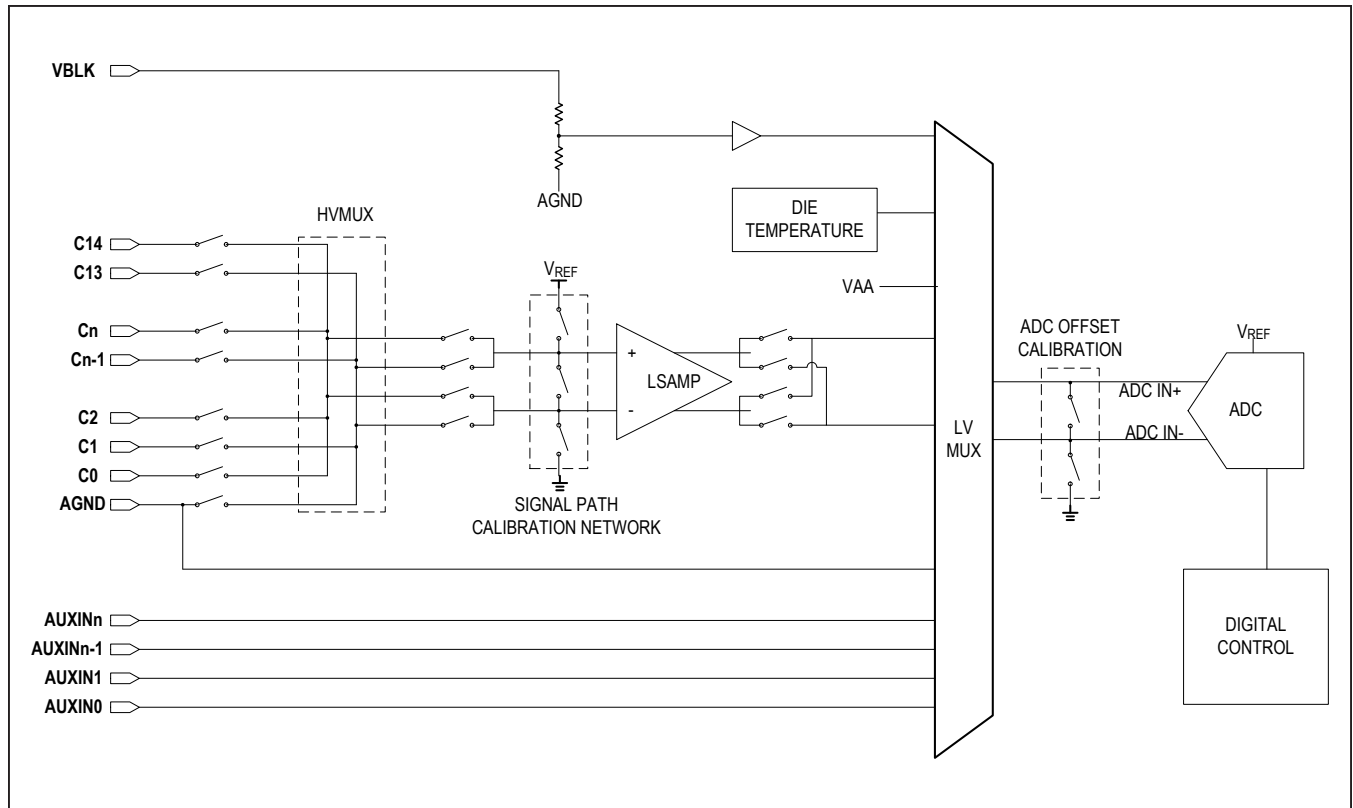

Figure 30. On-Demand Calibration Block Diagram

Calibration Alerts

Internal safety mechanisms are implemented to ensure that the applied calibration coefficients are within pre-determined bounds. If a calibration coefficient were to fall outside of these bounds, this would immediately raise a fault in the ALRTSUM register for the affected calibration process (ALRTCALOSADC, ALRTCALOSR, ALRTCALOSTHRM, ALRTCALGAINP, ALRTCALGAINR). This fault condition then propagates to the STATUS1 alert register which is capable of flagging an issue within the Data Check Byte or within the hardware alert interface.

If the integrity of the calibration coefficients is questionable, it is recommended to issue a new calibration to verify and/or correct the fault, or to de-assert ADCCALEN and use the factory default calibration.

Oversampling

ADC Oversampling

Oversampling performs multiple measurement cycles in a single acquisition and averages the samples to reduce the measurement noise and effectively increase the resolution of each acquisition. The net increase of the measurement resolution depends on the number of oversamples. To add n bits of measurement resolution at least 2²ⁿ oversamples are required. Since the ADC resolution is 12 bits, 13-bit resolution requires at least 4 oversamples. In order to achieve the maximum 14-bit resolution, at least 16 oversamples are required. Therefore with no oversampling, only the higher 12 bits of the measurement are statistically significant. With 4 or 8 oversamples, only the highest 13-bits are statistically significant. Taking more than 16 oversamples further reduces the measurement variation. With no oversampling, measurements can be averaged externally to achieve increased resolution but at a higher computational cost for the host.

Comparator Oversampling

To effectively mitigate high frequency noise from affecting the comparator measurement, the output can be oversampled using the OVSAMPL bits in the SCANCTRL register. The accumulated oversamples are digitally averaged from the comparator output to gauge if a valid OV, UV condition is present. An OV, UV condition require the comparator readings to meet or exceed the threshold listed in the table below for an alert to be generated as

shown in [Table 23](#). Thus, an OVSAMPL setting of 8 afford 1 sample outside of the OV/UV condition before setting an alert. It is recommended for higher noise immunity that the OVSAMPL setting should be configured to 8 or higher for comparator acquisition with oversampling. When the ADC and comparator are simultaneously sampled, the oversampling normally be set by the noise reduction required for ADC measurements.

Table 23. Comparator Faults for Alerts vs. Oversampling

OVSAMPL	COMPARATOR FAULTS FOR ALERT
1	1
4	1
8	2
16	3
32	5
64	10
128	20

Note: The comparator acquisition can be performed using the cell input path (C_N) or the switch input path (SW_N) as configured by the ALTMUXSEL bit. In the event that the comparator acquisition is performed on the switch input path, it is recommended to increase the oversampling to account for the lessened noise attenuation from the inputs due to the higher lowpass cutoff frequency.

Oversampling Watchdog Timeout

Table 24. Watchdog-Timeout Duration

OVSAMPL	SAMPLES	THEORETICAL RESOLUTION	ACQUISITION WATCHDOG TIMEOUT
0b000	1	12 bits	750 μ s
0b001	4	13 bits	3ms
0b010	8	13 bits	6ms
0b011	16	14 bits	12ms
0b100	32	14 bits	24ms
0b101	64	14 bits	48ms
0b110	128	14 bits	96ms

Note 1: When $AUTOBALSWDIS=1$, the watchdog timeout duration is extended by $SWDLY$ or $CELLDLY$ (depending on $ALTMUXSEL$).

Note 2: When $AUXTIME$ is > 0 , the timeout duration is extended by $AUXTIME$.

100Hz and 120Hz Filtering

There are two types of scan configurations in which oversampling frequency can be utilized, each providing a different benefit to the system performance.

The first configuration is entered through FOSR = 0b00, which performs the acquisition with minimal time delay between measurement cycles to recharge the HV charge pump. The FOSR=0b00 mode yields the highest number of measurements per sample period allowing for higher oversampling rates and further noise reduction. The total acquisition time is proportional to the number of oversamples configured by OVSAMPL and the type and number of enabled channels.

The FOSR settings of 0b01, 0b10 or 0b11 enables a notch filter at a frequency of 50Hz, 60Hz, 100Hz, or 120Hz. This mode can be particularly useful for accurate voltage detection during vehicle charging where noise from the power mains effect the voltage seen by the battery pack. To enable proper filtering for 50Hz or 100Hz, the FOSR must be set to 0b01. For 60Hz or 120Hz filtering, the FOSR must be set to either 0b10 or 0b11.

Note: When configuring the FOSR the acquisition period automatically be preconfigured to 625us for 50Hz/100Hz and 520µs for 60Hz/120Hz.

Table 25. FOSR Notch-Filter Setting

REJECTION FREQUENCY (Hz)	FOSR	OVSAMPL
50	0x1	0x4
60	0x2 or 0x3	0x4
100	0x1	0x4 or 0x3
120	0x2 or 0x3	0x4 or 0x3
None	0x0	don't care

Note: The typical notch-filter responses are shown for both 100Hz (Figure 31) and 120Hz (Figure 32), respectively.

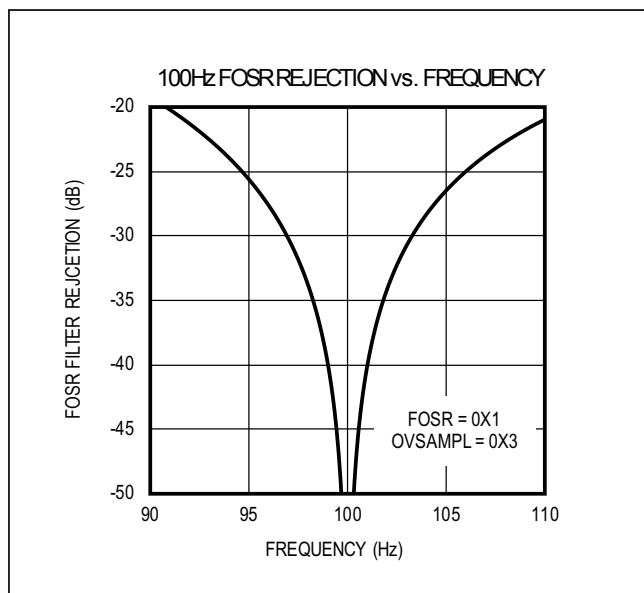

Figure 31. 100Hz Notch Filter

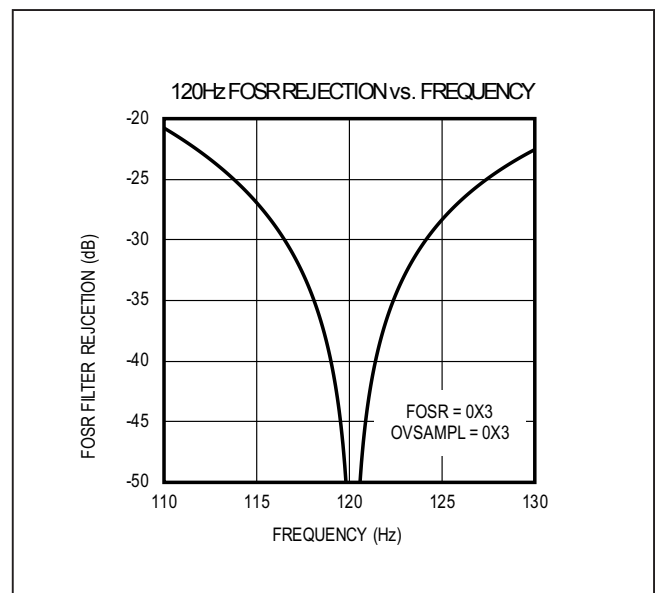

Figure 32. 120Hz Notch Filter

Acquisition Watchdog Timeout

If the acquisition does not finish within a predetermined time interval, the SCANTIMEOUT bit is set, the ADC logic is reset, the ALU registers are cleared, and the measurement data registers are also cleared. The acquisition watchdog timeout interval depends on the oversampling configuration as shown in [Table 24](#).

If double-buffer mode is enabled (DBLBUFEN = 1), the ALU registers are cleared but the data registers remain unchanged as these are known good values previously stored. Once a move operation is evoked (SCAN = 1), the previously cleared ALU data is moved from the ALU registers to the data registers and the data registers now show as cleared. Refer to the Double Buffer section for detailed information on the data control in mode.

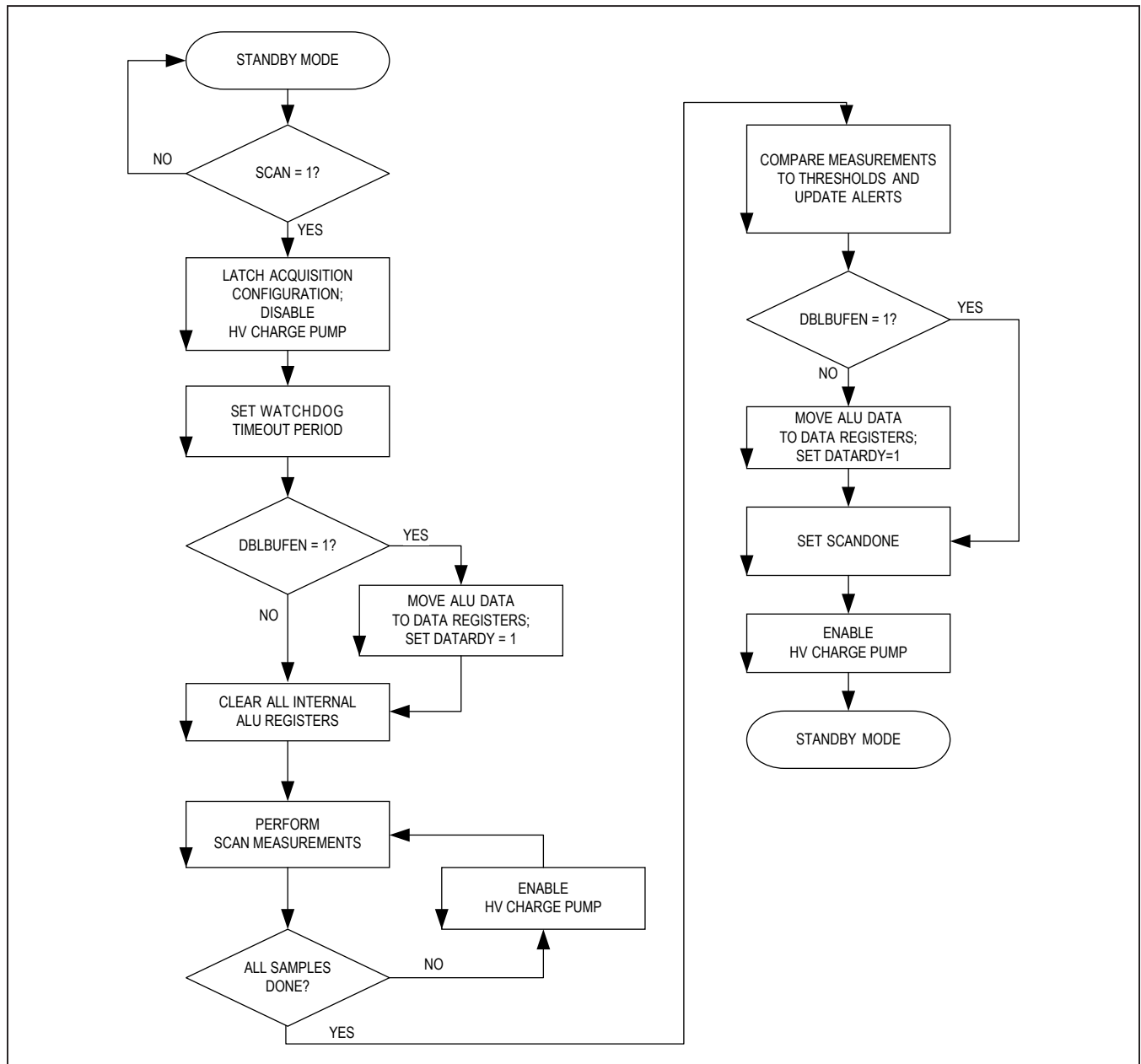

Figure 33. Acquisition-Mode Flowchart

Data Control

Acquisition Data Transfer and Control

The ADC data flow, [Figure 34](#), can be directed through multiple data processing paths until it reaches the register space (CELLnREG, AUXnREG, BLOCKREG, DIAG1REG, DIAG2REG, TOTALREG, and MINMAXCELL) depending on the enabled configuration. The following sections detail the data flow through:

- Calibration
- IIR Filter
- Single-Buffer Data Transfer
- Double-Buffer Data Transfer
- Cell balancing with Embedded Measurements

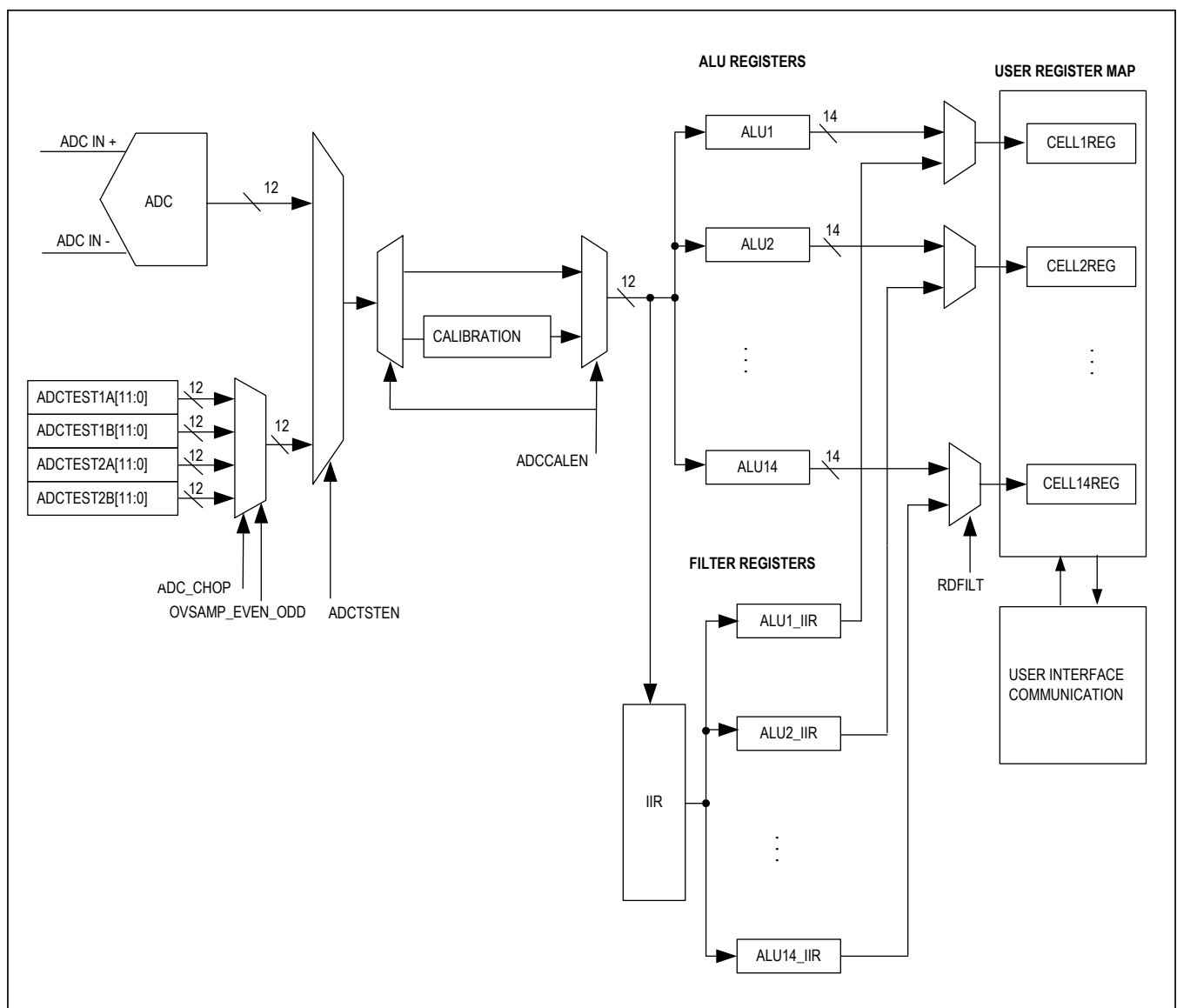

Figure 34. Data-Flow Diagram

Calibration Data Control

The ADC data is either directly output to the ALU or acted upon by the Calibration block depending on the state of the ADCCALEN bit. See the *Calibration* sections for details on the configuration and application of calibration.

IIR Filter

To augment the accuracy performance over multiple measurement cycles, the user can enable the embedded IIR filter. The filter acts upon all enabled CELLn and VBLOCK inputs according to the user defined settings in the MEASUREEN1 register. The TOTAL register does not have a unique IIR filter, but is instead directly computed from the sum of the IIR data registers as selected through RDFILT.

Additionally, when oversampling is enabled, the system response of the measurement data is the combination of the IIR filter and oversampling noise reduction.

Although the IIR filter can be updated dynamically on any individual acquisition through AMENDFILT, it is recommended to always allow non-diagnostic acquisitions into the IIR filter. Using the IIR filter leads to the greatest benefit in noise reduction with the external hardware filter combined with the digital filtering.

Diagnostics (including BALSWDIAG results) or higher noise data from ALTMUXSEL=1 should not be processed within the IIR as this corrupt the desired measurement result. This involves (but is not limited to) configuration with the diagnostic current sources (CTSTCFG, MUXDIAGEN).

Note: IIR filtering is always applied to the measurement cycle during automatic cell balancing. In the event the IIRFC=111b (off) in automatic Cell-Balancing modes, the IIR filter is internally forced to 000b (1/8). All other selection of IIRFC are valid.

Filter Description

The IIR filter is implemented per the following transfer function, [Figure 35](#):

Equation 1:

$$Y(n) = FC * X(n) + (1-FC) * Y(n-1)$$

FC is a 3-bit user-programmable filter coefficient. The default value of 0b010 has a weight of 3/8.

The detailed filter coefficient settings are defined in the IIRFC register. The smaller that coefficient is, the more the history represented by Y(n-1) outputs in Equation 1. It is a trade-off between response times to change in input value versus the noise attenuation.

The filter can be turned off by setting the filter coefficient to 1 (IIRFC=0b111). The filter can be temporarily bypassed by setting AMENDFILT=0; this is useful when performing periodic safety and diagnostic checks, as the filtered main measurement results be preserved within the filter memory registers. Both filtered and raw result data can be read back using the RDFILT option.

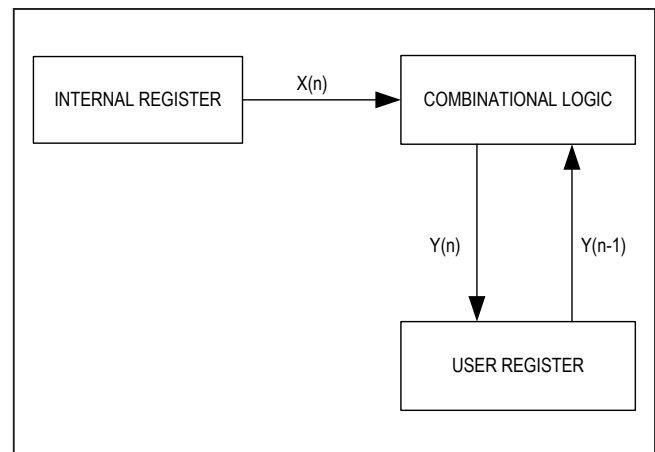

Figure 35. IIR Filter Algorithm

Filter Response

The IIR Filter provides a means to improve measurement noise rejection at a cost of increased settling time. This tradeoff can be managed by selecting the proper IIR Filter Coefficient for the application. [[IIR 100mV Scale Step Response Settling]] shows the number of samples taken by the IIR Filter to settle a full-scale step

(ex. 0V to 100mV Unipolar Cell transition) to 12-bit and 14-bit accuracy. **Note:** This settling time can be significantly shortened after power-up, or when operating mode changes require large step responses by using the MEASUREEN2:SCANIIRINIT or BALCTRL:CBIIIRINIT initialization options, which accelerate settling by loading the next acquired sample into the filter's accumulated result memory.

Table 26. IIR 100mV Step Response Settling

IIRFC SETTING:	0b000	0b001	0b010	0b011	0b100	0b101	0b110	0b111
IIR FILTER COEFFICIENT (FC):	1/8	1/4	3/8	1/2	5/8	3/4	7/8	1
12-BIT SETTling (# SAMPLES):	33	16	10	7	5	4	3	1
14-BIT SETTling (# SAMPLES):	44	21	13	9	6	5	3	1

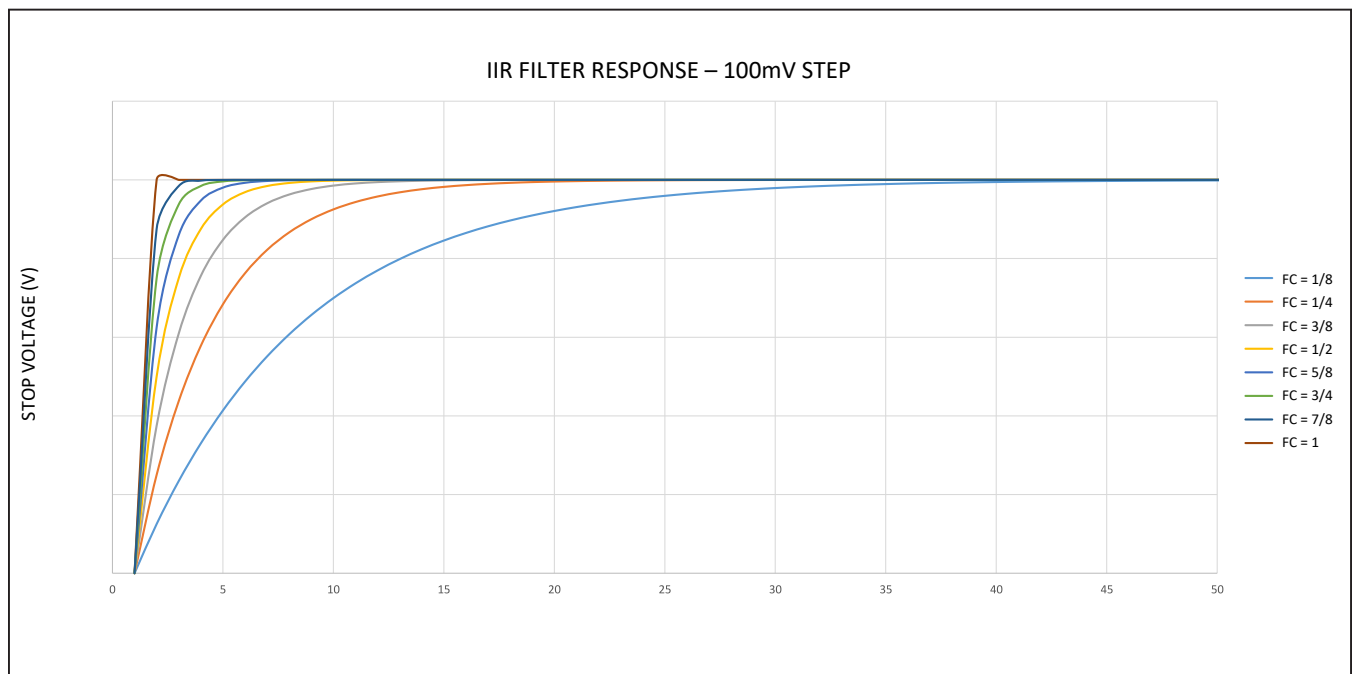

Figure 36. 100mV IIR Step Response

IIR Data Control

The control of ADC data into and around the IIR filter is performed using dedicated register bits (AMENDFILT, RDFILT, ALRTFILT) in the SCANCTRL register. The following sections detail this operation.

AMENDFILT and RDFILT

The AMENDFILT bit directs the ALU data into the IIR for filtering operations or around the IIR filter to the output data registers (CELLn and BLOCKREG).

When the AMENDFILT bit is deasserted, the ADC acquisition in the ALU is not transferred into the IIR accumulator at the end of the scan sequence. This setting should be used for diagnostic operations which disrupt the input data or for operations which utilize a different measurement path, as both operations would corrupt the normal data. Examples of measurement modes which disrupt the input data are when the cell test current sources or HVMUX test current sources are enabled using the CTSTEN bit and MUXDIAGEN bits respectively. Alternatively, when AMENDFILT is asserted, the ADC acquisition in the ALU is automatically scaled and transferred into the IIR accumulator at the end of the scan sequence.

The RDFILT bit determines if IIR filtered data or normal acquisition data is read from the output data registers is issued (CELLn and BLOCKREG). See the [Single-Buffer Mode](#) and [Double-Buffer Mode](#) sections for details on how the RDFILT affects data transfer.

Note: If DBLBUFEN=0 and SCAN=1, the ALU results are loaded into the IIR automatically at the end of the requested measurement sequence.

If DBLBUFEN=1 and SCAN=1, the ALU results are loaded into the IIR automatically at the beginning of the following sequence.

If DBLBUFEN=x and SCAN=0, the ALU results are loaded into the IIR during the requested data move sequence if DATARDY=0.

[Table 27](#) shows the interactions that can occur between the IIR Data Control Setting:

ALRTFILTSEL

When IIR filter operation is enabled, there are two possible data sources for user access, the raw sequencer outputs (oversampling still applies), or the IIR filtered outputs. The Alert Filtering Selection bit (ALRTFILTSEL) is used to select one of these outputs to generate the relevant alerts.

When ALRTFILTSEL=0, the raw sequencer outputs are used. This data source is used to assert all related alert bit assertions, calculate MINMAXCELL and TOTAL registers, and cell mismatch MSMTCH checks.

When ALRTFILTSEL=1, the IIR filtered data is used. This IIR data is used to assert all related alert bit assertions, calculate MINMAXCELL and TOTAL registers, and cell mismatch MSMTCH checks.

Regardless of the ALRTFILTSEL setting, DIAG1 and DIAG2 register always come from the unfiltered sequencer outputs.

IIR Initialization

When IIR operation is engaged, the data to be operated upon initially is controlled by the Sequencer IIR Initialization Request bit (SCANIIRINIT).

By default, SCANIIRINIT=0, IIR filter is in continuation mode. In Continuation mode, the current value in the IIR accumulators is kept (presumably from previous cell measurements) and sequencer measurements are amended normally.

Table 27. IIR Data-Control Settings

AMENDFILT	RDFILT	USAGE
0	0	IIR Filter Disabled
0	1	Potential Stale-Data Fetch IIR is not updated but IIR results read. Note: This operation is not recommended.
1	0	Reads Current Unfiltered Acquisition Data: IIR is updated but current acquisition read. See the Out-of-Scan Data Transfer section for information on reading both filtered and unfiltered results
1	1	IIR Filter Updated and IIR Filter Read

When SCANIIRINIT=1, IIR filter is in initialization mode. In Initialization mode, the IIR accumulators be reinitialized to the first measurement taken, and further cell-balancing measurements are amended normally.

Single-Buffer Mode

Single-buffer Mode (Figure 37) is activated when DBLBUFEN=0. In this mode data is moved to the CELLnREG, AUXnREG, BLOCKREG, DIAG1REG, DIAG2REG, TOTALREG, and MINMAXCELL registers at the end of the scan indicated by SCANDONE=1 and DATARDY=1.

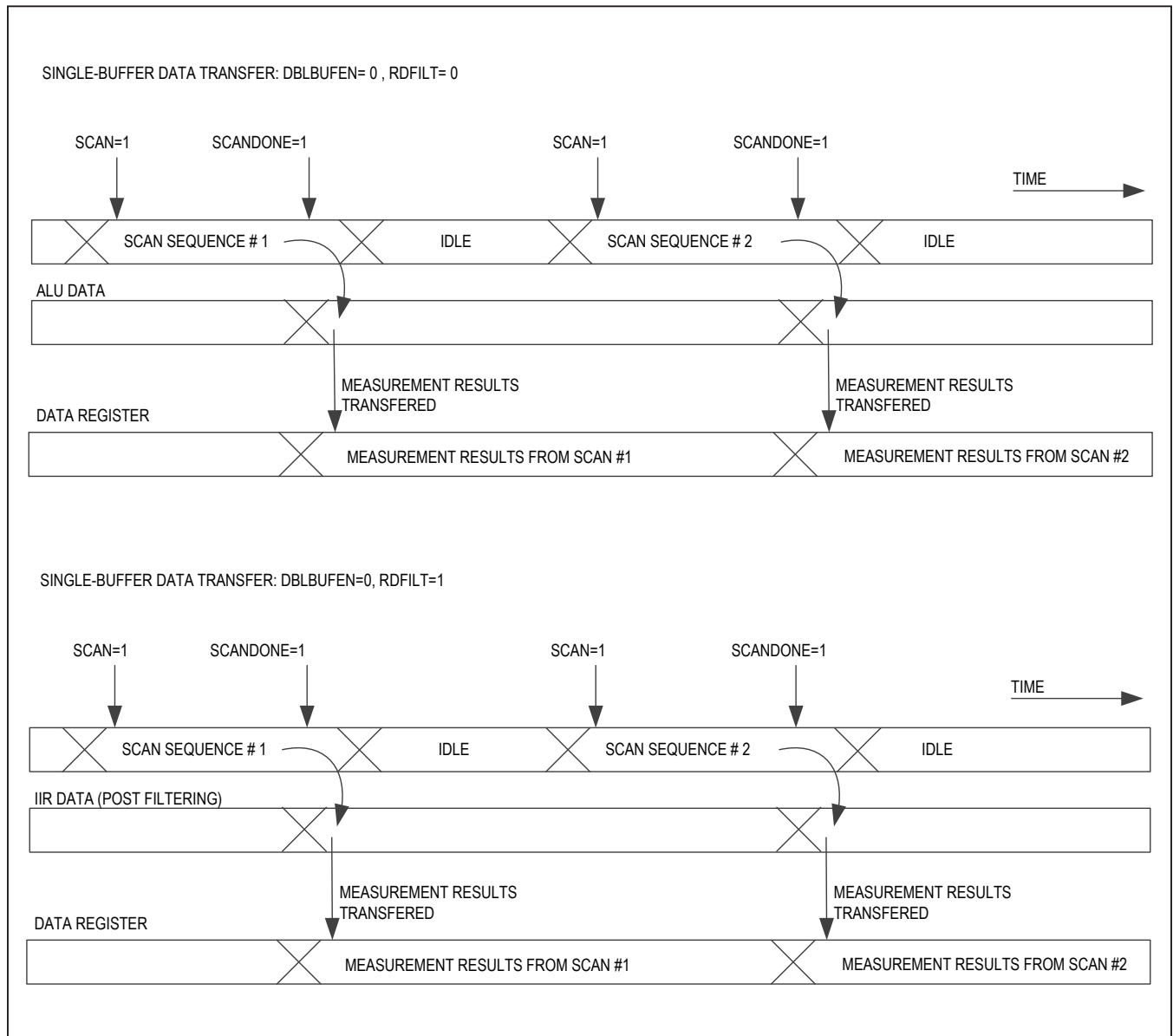

Figure 37. Single-Buffer Data Transfer

Double-Buffer Mode

With $DBLBUFEN = 1$, the Double Buffer Mode, [Figure 38](#), is activated. In this mode data is moved to the $CELLnREG$, $AUXnREG$, $BLOCKREG$, $DIAG1REG$, $DIAG2REG$, $TOTALREG$, and $MINMAXCELL$ registers at the start of the next scan when $SCAN = 1$ and is indicated by $DATARDY = 1$. This allows the host to read data from the last scan while the current scan is in progress. In the event that a final measurement is requested prior to a sleep or shutdown event, the host would need to issue another $SCAN$ request to force the data transfer from the last acquisition or move the data through the Out-of-Scan data transfer method.

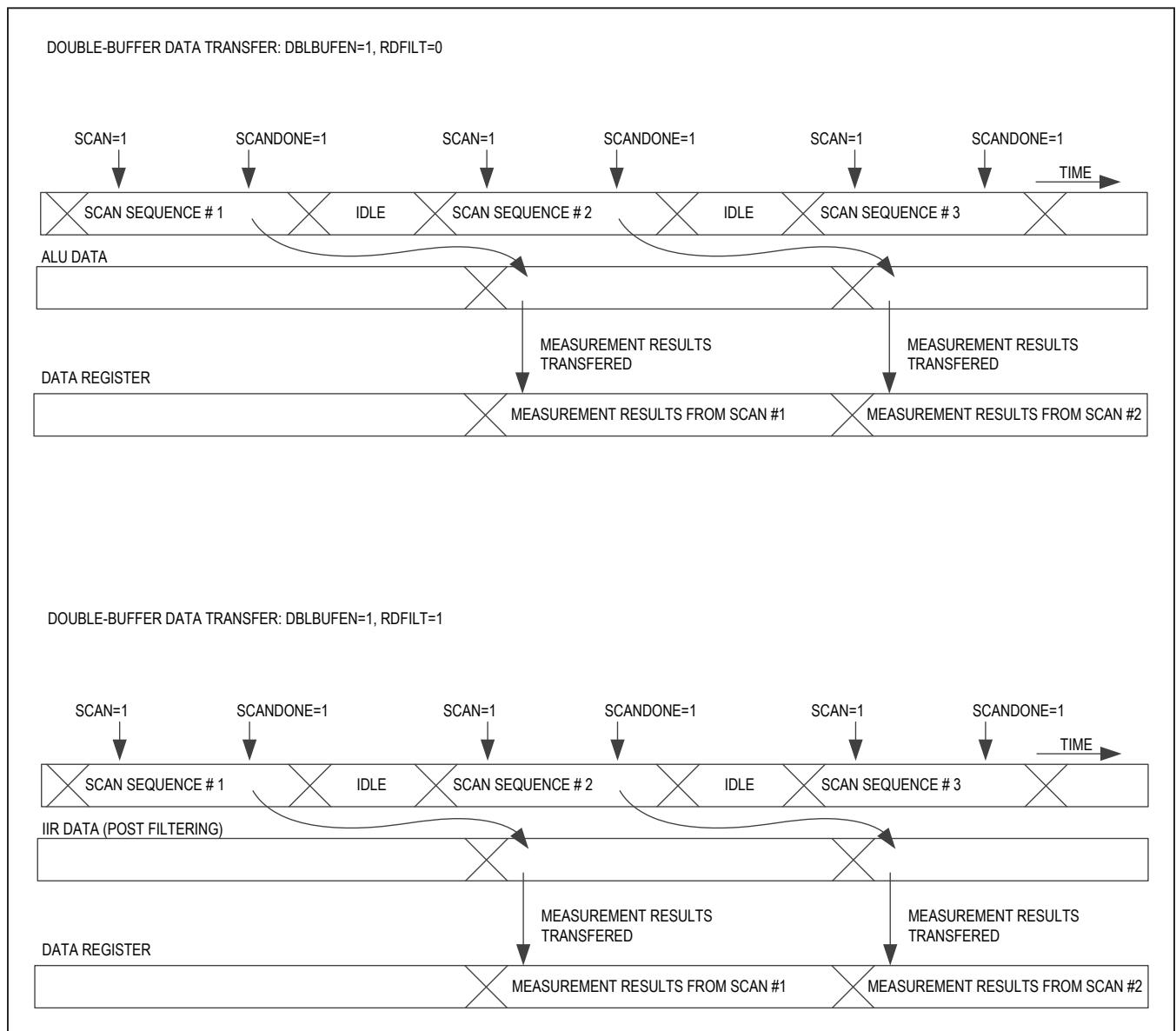

Figure 38. Double-Buffer Data Transfer

Out-of-Scan Data Transfer

Out-of-Scan data transfer occurs in the period after a scan is complete, indicated by SCANDONE=1, and before a new scan request, SCAN=1, is issued by the host. Since data exists in both the ALU and IIR accumulator but only one set is transferred to the data registers depending on the RDFILT setting, this procedure allows access to the other set of data that was not transferred to the data registers. By setting DATARDY=0, RDFILT=0 and SCAN=0, data from the ALU is transferred to the data registers. By setting DATARDY=0, RDFILT=1 and SCAN=0, data from the IIR accumulator is transferred to the data registers.

If an Out-of-Scan data transfer is issued the MINMAXCELL, TOTAL, and MSMTCH registers are not updated when changing RDFILT and SCAN=0. Additionally, Out-of-Scan alert processing not be updated when changing ALRTFILTSEL and SCAN=0. If updated data processing is required a new acquisition (SCAN=1) must be requested.

Cell Balancing with Embedded-Measurement Data Control

The data control for cell balancing with embedded measurements is controlled by the CBSCAN bit in the BALDATA register. This bit acts as a strobe, and the CBSCAN bit content is automatically cleared, reading back a logic zero when polled.

Upon writing CBSCAN (and after any auto cell-balancing measurement operation in complete), all enabled conversion parameters are updated in the CELLnREG, AUXnREG, BLOCKREG, DIAG1REG, DIAG2REG, TOTALREG, and MINMAXCELL output registers. See the [Cell Balancing](#) section for further detail.

Measurement Alerts

After the acquisition, the ALU compares the enabled measurement data to the enabled OV/UV thresholds for both measurement paths (ADC and Comparator) as shown in [Table 28](#). If outside of the configured threshold, the associated alert bit is set during data transfer into the ALU or IIR ALU blocks. In the event that calibration is enabled using the ADCCALEN bit, the digital correction is performed prior to the alert generation. This ensures that the alert is generated from the correct accuracy results.

Note: The ALRTFILTSEL bit for the IIR data control determine if the alerts be generated upon filtered or unfiltered data.

The data control settings impact the management of alert signaling. The aforementioned alert handling details the Single Buffer Mode data control. Since Double Buffered Mode allow for simultaneous data offload and acquisition, it is recommended to read alert status after the SCANDONE for the current acquisition and prior to initiating the next acquisition.

Table 28. Measurement Alerts

DESCRIPTION	SIGNAL PATH	CONDITION OR RESULT	ALERT BIT	LOCATION
Cell overvoltage (OV)	ADC	$V_{Cn} - V_{Cn-1} > V_{OVTHSET}$ for POLARITY _n =0	ALRTCELLOVST, ALRTADCOVST, ALRTOV _n	STATUS1, ALRTSUM, ALRTOVCELL
Cell overvoltage (OV)	COMP	$V_{Cn} - V_{Cn-1} > V_{COMPOVTH}$	ALRTCELLOVST, ALRTADCOVST, ALRTCOMPOV _n	STATUS1, ALRTSUM, ALRTCOMPOVREG
Cell undervoltage (UV)	ADC	$V_{Cn} - V_{Cn-1} < V_{UVTHSET}$ for POLARITY _n =0	ALRTCELLUVST, ALRTADCUVST, ALRTUV _n	STATUS1, ALRTSUM, ALRTUVCELL
Cell undervoltage (UV)	COMP	$V_{Cn} - V_{Cn-1} < V_{COMPUVTH}$	ALRTCELLUVST, ALRTADCUVST, ALRTCOMPUV _n	STATUS1, ALRTSUM, ALRTCOMPUVREG
Bipolar cell/bus-bar overvoltage (OV)	ADC ONLY	$V_{Cn} - V_{Cn-1} > V_{BIPOVTHSET}$ for POLARITY _n =1	ALRTCELLOVST, ALRTADCOVST, ALRTOV _n	STATUS1, ALRTSUM, ALRTOVCELL

Table 28. Measurement Alerts (continued)

DESCRIPTION	SIGNAL PATH	CONDITION OR RESULT	ALERT BIT	LOCATION
Bipolar Cell/Bus-bar undervoltage (UV)	ADC Only	$V_{Cn} - V_{Cn-1} < V_{BIPUVTHSET}$ for POLARITY _n =1	ALRTCELLUVST, ALRTADCUVST, ALRTUV _n	STATUS1, ALRTSUM, ALRTUVCELL
Block overvoltage (OV)	ADC Only	$V_{BLK} > V_{BLKOVTHSET}$	ALRTBLKOV	STATUS1
Block undervoltage (UV)	ADC Only	$V_{BLK} < V_{BLKUVTHSET}$	ALRTBLKUV	STATUS1
Cell Mismatch	ADC Only	$V_{MAX} - V_{MIN} > V_{MSMTCH}$	ALRTMSMTCH	STATUS1
Cell with minimum voltage	ADC Only	n where $V_{CELLn} = V_{MIN}$ Unipolar if MINMAXPOL=0 else Bipolar	None	MINMAXCELL
Cell with maximum voltage	ADC Only	n where $V_{CELLn} = V_{MAX}$ Unipolar if MINMAXPOL=0 else Bipolar	None	MINMAXCELL
Total of all Cell voltages	ADC Only	$\sum V_{CELLn}$ for n=1 to TOPCELL1/2	None	TOTAL
AUXIN _n overvoltage (undertemperature)	ADC	$V_{AUXINn} > (V_{AUXROVTHSET}$ or $V_{AUXAOVTHSET})$	ALRTAUXOVST, ALRTADCAUXOVST, ALRTAUXOV _n	STATUS1, ALRTSUM, ALRTAUXOV
AUXIN _n overvoltage (undertemperature)	COMP	$V_{AUXINn} > (V_{COMPAUXROVTH}$ OR $V_{COMPAUXAOVTH})$	ALRTAUXOVST, ALRTCOMPAUXOVST, ALRTCOMPAUCOV _n	STATUS1, ALRTSUM, ALRTCOMPAUXOV
AUXIN _n undervoltage (overtemperature)	ADC	$V_{AUXINn} < (V_{AUXRUVTHSET}$ OR $V_{AUXAUVTHSET})$	ALRTAUXUVST, ALRTADCAUXUVST, ALRTAUXUV _n	STATUS1, ALRTSUM, ALRTAUXUV
AUXIN _n undervoltage (overtemperature)	COMP	$V_{AUXINn} < (V_{COMPAUXRUVTH}$ OR $V_{COMPAUXAUVTH})$	ALRTAUXUVST, ALRTCOMPAUXUVST, ALRTCOMPAUCUV _n	STATUS1, ALRTSUM, ALRTCOMPAUXUV

Table 29. Set- and Clear-Threshold Selection

DESCRIPTION	SIGNAL PATH	OVERVOLTAGE THRESHOLD	UNDervOLTAGE THRESHOLD	OV HYSTERESIS	UV HYSTERESIS
Cell	ADC	OVTHSET	UVTHSET	OVTHCLR	UVTHCLR
Cell	COMP	COMPOVTH	COMPUVTH	Not Applicable	Not Applicable
Bus bar	ADC	BIPOVTHSET	BIPUVTHSET	BIPOVTHCLR	BIPUVTHCLR
Block	ADC	BLKOVTHSET	BLKUVTHSET	BLKOVTHCLR	BLKUVTHCLR

Voltage Alerts

The ALRTOVEN and ALRTUVEN registers are configured to enable voltage alerts for the CELL and Block inputs. These alerts have programmable OV and UV set thresholds as well as programmable OV and UV clear thresholds allowing for programmable hysteresis in both OV or UV measurements as mentioned in below [Table 29](#). This is beneficial for the programming of alert detection in lithium ion cells where the different characteristics at fully charged and discharged states.

Overvoltage alerts in the ALRTOVCELL or ALRTCOMPOVREG registers are set when the CELL_n voltage exceeds the programmed threshold voltages V_{OVTHSET} and V_{COMPOVTH} respectively. Alternatively, undervoltage alerts in the ALRTUVCELL and ALRTCOMPUVREG registers are set when the CELL_n voltage exceeds the programmed threshold voltage V_{UVTHSET} and V_{COMPUVTH} respectively. It is important to note that due to the different resolutions of the ADC and comparator (described in the [ADC Input Range](#) and [Comparator Input Range](#) sections) the user may experience a condition where the alert for the ADC may be set while the alert for the comparator may be cleared and vice versa.

Note: ADC alerts provide the most accurate indications of the acquisition.

Alerts are cleared when the cell voltage moves in the opposite direction and crosses the OVTHCLR, COMPOVTH and UVTHCLR, COMPUVTH thresholds. The voltage must cross the threshold; if it is equal to a threshold, the alert flag does not change. Therefore, setting the overvoltage

set threshold to full-scale, or setting the undervoltage set threshold to zero-scale, effectively disables voltage alerts independent of the ALRTOVEN and ALRTUVEN.

Alert conditions for the individual ADC Cell inputs are summarized using the ALRTADCOVST and ALRTADCUVST bits in the ALRTSUM register and occur when any alert bit is set in the ALRTOVCELL or ALRTUVCELL registers, respectively. Similarly, alert conditions for the individual Comparator Cell inputs are set using the ALRTCOMPOVST and ALRTCOMPUVST bits in the ALRTSUM register when any alert bit is set in the ALRTCOMPOVREG or ALRTCOMPUVREG registers, respectively. To ease identification of any OV or UV alerts, both ADC summary alerts and Comparator summary alerts are further logically OR'ed and summarized in the ALRTCELLOVST and ALRTCELLUVST bits in the STATUS1. This enables the alert information to get propagate using the hardware alert interface or the data check byte.

Alert conditions for the Block input are directly summarized using the ALRTBLKOVST and ALRTBLKUVST bits in the STATUS1 register when the acquired BLOCK voltage is over V_{BLKOVTHSET} or under V_{BLKUVTHSET} respectively.

If an alert does not need to be propagated using the alert interface or data check byte, these can be individually masked. See the Alert interface for further details on the masking.

The cell and block voltage hysteresis diagram is as shown in below [Figure 39](#).

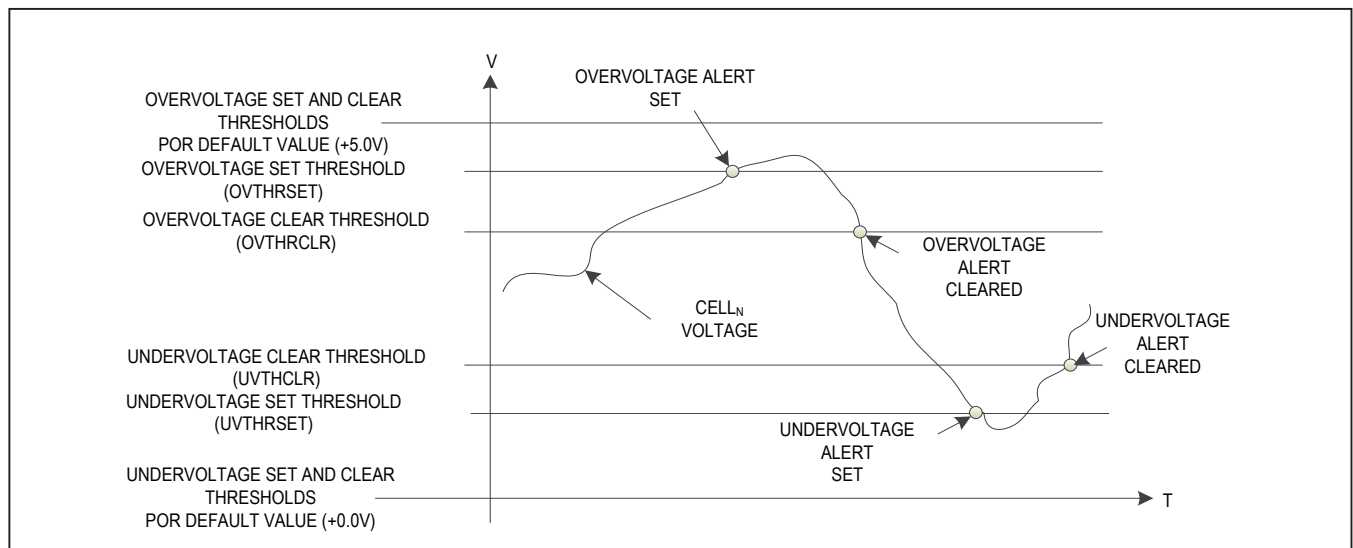

Figure 39. Cell Voltage-Alert Thresholds

Cell Mismatch

Enable the mismatch alert to signal when the minimum and maximum cell voltages differ by more than a specified voltage. The MSMTCHREG register sets the 14-bit threshold ($V_{MSMTCHREG}$) for the mismatch alert, ALRTMSMTCH. Whenever $V_{MAX} - V_{MIN} > V_{MSMTCHREG}$, then ALRTMSMTCH = 1. The alert bit is cleared when a new acquisition does not exceed the threshold condition. To disable the alert, write 3FFFh to the MSMTCHREG register bitfield (default value).

Cell Statistics

The cell numbers corresponding to the lowest and highest enabled voltage measurements are stored in the MINCELL and MAXCELL bitfields. When multiple cells have the same minimum or same maximum voltage, only the lowest cell position having that voltage is reported. For acquisitions with no enabled cell inputs, the MINCELL and MAXCELL bitfields, and the TOTALREG register are not updated.

The RDFILT bit determines the source data (filtered/unfiltered) used for the MINCELL and MAXCELL bitfields, and the TOTALREG register.

The MINMAXPOL bit ensures that only like measurements are used for the statistical processing of MINCELL, MAXCELL and ALRTMSMTCH. This ensures that bus bars do not affect the cell statistics in mixed-mode acquisitions. When MINMAXPOL = 0 only unipolar measurements are used. When MINMAXPOL = 0b1, only bipolar measurements are used upon unipolar or bipolar measurements.

Note: For lithium-ion applications, MINMAXPOL should be configured for unipolar statistics, while fuel-cell application should be configured for bipolar statistics.

The sum of all enabled cell voltages, irrespective of the POLARITY configuration, are stored in the TOTALREG register as a 16-bit value.

Example:

Assume four cell inputs are enabled (CELL1, CELL2, CELL3, and CELL4, where CELL1 and CELL2 are configured as unipolar, CELL3 is bipolar, and CELL4 is unipolar.

The measured values after the acquisition reads 2V, 2V, -1V, and 2.5V, respectively.

The TOTALREG register reads:

$$\text{TOTALREG} = 2 + 2 - 1 + 2.5 = 5.5\text{V}$$

The MINCELL bitfields read CELL1 and the MAXCELL register read CELL4.

Temperature Alerts

The ALRTAUXOVEN and ALRTAUXUVEN registers are configured to enable the temperature alerts for the enabled AUXn inputs. Like the cell-voltage alerts, the temperature alerts have programmable OV and UV set thresholds, as well as programmable OV and UV clear thresholds, to provide user-programmable hysteresis to avoid unwanted alerts in the presence of measurement noise, as shown in [Table 30](#).

Overvoltage alerts in the ALRTAUXOVEN or ALRTCOMPAUXOV registers are set when the AUXn voltage exceeds the programmed threshold voltages of $V_{AUXAOVTHSET}$ or $V_{AUXROVTHSET}$, and $V_{COMPAUXAOVTH}$ or $V_{COMPAUXROVTH}$, respectively. The appropriate threshold used is determined by the AUXREFSEL bits which can be different per channel. Alternatively, undervoltage alerts in the ALRTAUXUVEN and ALRTCOMPAUXUVEN registers are set when the AUXn voltage exceeds the programmed threshold voltage $V_{AUXUVTHSET}$ or $V_{AUXRUVTHSET}$, and $V_{COMPAUXRUVTH}$ or $V_{COMPAUXAUVTH}$, respectively. It is important to note that due to the different resolutions of the ADC and comparator (described in the [ADC Input Range](#) and [Comparator Input Range](#) sections), the user may experience a condition where the alert for the ADC is set, while the alert for the comparator is cleared, and vice versa.

Note: An OV alert for the ratiometric acquisition signal an undertemperature (UT) event for the NTC measurement and an UV alert signal an overtemperature (OT) event for the NTC measurement.

Table 30. Temperature-Alert Threshold

DESCRIPTION	SIGNAL PATH	TYPE	OVERVOLTAGE THRESHOLD/UNDER TEMPERATURE	UNDervOLTAGE THRESHOLD/OVER TEMPERATURE	HYSTERESIS OV	HYSTERESIS UV
AUXINn	ADC	Ratio metric	AUXROVTHSET	AUXRUVTHSET	AUXROVTH-CLR	AUXRUVTHCLR
AUXINn	ADC	Absolute	AUXAOVTHSET	AUXAUVTHSET	AUXAOVTH-CLR	AUXAUVTHCLR
AUXINn	COMP	Ratiometric	COMPAUXROVTH	COMPAUXRUVTH	Not Applicable	Not Applicable
AUXINn	COMP	Absolute	COMPAUXAOVTH	COMPAUXAUVTH	Not Applicable	Not Applicable

Alerts are cleared when the cell voltage moves in the opposite direction and crosses the AUXROVTHCLR, AUXAOVTHCLR and AUXRUVTHCLR, AUXAUVTHCLR thresholds. The voltage must cross the threshold; if it is equal to a threshold, the alert flag does not change. Therefore, setting the overvoltage set threshold to full-scale, or setting the undervoltage set threshold to zero-scale, effectively disables voltage alerts independent of the ALRTAUXOVEN and ALRTAUXUVEN.

Alert conditions for the individual ADC auxiliary inputs are summarized using the ALRTADCAUXOVST and ALRTADCAUXUVST bits in the ALRTSUM register and occur when any alert bit is set in the ALRTAUXOV or ALRTAUXUV bitfields, respectively.

Note: The ALRTSUM alert status does not specify the auxiliary input measurement mode in AUXREFSEL, however, this can be determined from polling the alert channel within ALRTAUXOV or ALRTAUXUV

Similarly, alert conditions for the individual comparator auxiliary inputs are set using the ALRTCOMPAUXOV and ALRTCOMPAUXUV bits in the ALRTSUM register when any alert bit is set in the ALRTCOMPAUXOVSTREG or ALRTCOMPAUXUVVREG registers, respectively.

To ease identification of any OV or UV alerts, both ADC summary alerts and Comparator summary alerts are further logically OR'ed and summarized in the ALRTAUXOVST and ALRTAUXUVST bits in the STATUS1. This enables the alert information to get propagated using the hardware alert interface or the data check byte.

Cell Balancing

Cell balancing can be performed using any combination of the 14 internal cell-balancing switches according to the programming of the enabled BALSCTRL:BALSWEN configuration and POLARITYCTRL configuration. Each configured channel performs cell balancing according to the configured operational mode, which includes manual or automatic balancing-discharge control using a timer and/or undervoltage threshold, as well as duty-cycle configuration.

Cell-Balancing Mode Configurations

Cell balancing is initiated using the CBMODE bits in the BALCTRL register. This selection defines automatic versus manual balancing control, channel timer configuration, and timer resolution. Once a CBMODE mode is

selected and started, the device remains in this mode until a new value is written to CBMODE, or until a successful exit criteria is achieved from all enabled conditions (UV threshold, timer, and thermal).

To determine the current state of cell balancing, the CBACTIVE bits can be polled using the BALCTRL, BALSTAT or BALUVSTAT registers. The current timer value can be read through CBTIMER, a 1Hz alive counter can be read through CBCNTR. The timer units (i.e., second, minute, hour) can be read through CBUINT. These status registers are only cleared when CBMODE is written to a new mode or disabled. The combination of these bitfields allow for user verification that the cell balancing machine is responsive, meanwhile an internal health check is performed prior to verify a hardware integrity prior to balancing. ALRTCBTIMEOUT notifies the user a health check failure (if one is found).

Once a CBMODE mode is selected and started, the device remains in this mode until a new value is written to CBMODE. Note that all CBMODE active operations automatically end due to either timer expiration(s), thermal faults, and/or cell UV thresholds being met. In these cases, the CBMODE is still engaged, although the balancing operation is ended (the status of the operation can be checked by reading the BALSTAT and BALUVSTAT registers).

After cell balancing is initiated, write access to specific cell-balancing registers is blocked; if a write to a blocked register is attempted, it is ignored and the ALRTRJCT flag set in the STATUS2 register. See [Table 31](#) for specific register behavior. Note that blockage operations are implemented at the register level.

Notes: The CBRESTART is a strobe bit to manually restart/refresh the watchdog timer during a cell-balancing operation in manual mode. Although this can be written in other balancing modes, no internal action is taken.

Writes to the BALSLEN bitfields during manual Cell-Balancing mode are expected and supported.

Writes to BALAUTOVTHR with CBUVMINCELL=1 are rejected if a measurement scan is in progress (since data from the last completed scan is used to populate CBUVTHR).

Any value rewritten to CBMODE other than 000 (disable) restarts the CBTIMER at zero and relaunches the requested mode of operation.

Table 31. Cell-Balancing Register Write Behavior when Cell Balancing is Selected

REGISTER	BITFIELD	AUTO (INDIVIDUAL OR GROUP) MODE (1xx)			MANUAL MODE (01x)			EMERGENCY-DISCHARGE MODE (001)		
		Data applicable in this mode?	Write accepted in this mode?	ALRT-RJCT Status	Data applicable in this mode?	Write accepted in this mode?	ALRT-RJCT Status	Data applicable in this mode?	Write accepted in this mode?	ALRT-RJCT Status
BALSWCTRL	CBRESTART	No	No	1	Yes	Yes	—	No	Yes	—
	BALSWEN	Yes	No		Yes	Yes		No	Yes	
BALEXP1	BALEXP1	Yes	No	1	Yes	No	1	Yes	No	1
BALEXP2-14	BALEXP2-14	Yes	No	1	No	Yes	—	No	Yes	—
BALAUTOU-VTHR	CBUVTHR	Yes	No	1	No	Yes	—	No	Yes	—
	CBUVMIN-CELL	Yes	No		No	Yes		No	Yes	
BALDLYCTRL	CBNTFYCFG	Yes	No	1	No	Yes	—	Yes	No	1
	CBCALDLY	Yes	No		No	Yes		Yes	No	

Manual Mode

In manual mode, balance switches (BALSW_n) are controlled directly by BALSWEN[14:1] with a watchdog timeout set by CBEXP1 as follows:

$$\text{BALSW}_n = \text{BALSWEN}[n] \& (\text{CBTIMER} \leq \text{CBEXP1}) \& \sim(\text{AUTOBALSWDIS} \& \text{measurement in progress})$$

CBTIMER is incremented on a real-time basis, regardless of BALSWEN settings or suspensions for ADC or CAL events. This means the watchdog timeout is set in CBEXP1 once manual cell balancing is initiated.

Manual cell-balancing operations can be temporarily suspended during measurements using the AUTOBALSWDIS feature.

In certain instances, as defined by the AUTOBALSWDIS operation or other manual diagnostic operation, the user may wish to have explicit control of the BALSWEN without wanting to refresh the CBTIMER watchdog. In this case, the user can configure CBEXP1=3FFh to disable the timer. Thus, balancing will be controlled only using the BALSWEN; this is also equivalent to the cell-balancing behavior supported in Maxim legacy battery-management devices.

CBRESTART is provided as a means to refresh the active balancing switches or the watchdog timer during normal BALSW_n cycling operations. CBUVTHR exit settings are ignored, measurements and calibrations operations are requested through normal scan-control registers allowing for simultaneous measurements and balancing.

Notes: Writing 1 to CBRESTART after the cell-balancing timer expiration has no effect. To perform another manual-mode cell-balancing event, the user must issue a separate write to the BALCTRL register.

Manual balancing allows for adjacent balancing switches to turn on simultaneously according to the application requirement. Enabling adjacent balancing switches simultaneously under manual Cell-Balancing mode increases the balancing current significantly, so care must be taken not to exceed the device's maximum operating conditions.

AUTOBALSWDIS Feature

Configuring AUTOBALSWDIS=1 automatically disables the balancing switches (in manual Cell-Balancing modes only) during measurements to eliminate the additional voltage drop caused due to the cell-balancing application circuit. This ultimately allows the system to achieve higher accuracy cell measurements to help calculate higher accuracy of state-of-charge (SOC).

Measurement settling-time control for cell measurement (CELLDLY) and BALSW diagnostic/ALTMUX (SWDLY) is configured in the BALSWDLY register. These delay registers provides programmable settling (wait) times from 0μs up to 24.57ms, in steps of 96μs, between the time when the acquisition is enabled and the start of actual measurement to allow for the external application circuit to settle to accurate voltages. In the BALSWDLY register, CELLDLY is the upper 8-bit delay setting for cell-recovery time while SWDLY is the lower-delay setting for certain diagnostics

such as sense-wire open. When AUTOBALSWDIS=1 and ALTMUXSEL=0, CELLDLY is selected. When AUTOBALSWDIS=1 and ALTMUXSEL=1, SWDLY is selected. Hence, this feature can be used during normal cell measurements as well as during diagnostic measurements with two separate delay timers that can be independently set. Any write to the BALSWDLY register be ignored, signaled by ALRTRJCT, while a measurement sequence or an automated Cell-Balancing mode is active.

Note: The appropriate delay time is dependent on the application circuit and the level of accuracy required. For the typical application circuit on the cell input, utilizing a input filter network of 1kΩ and 0.1μF, it is recommended to choose a settling time of 960μs to achieve calibrated accuracy specified in the [Electrical Characteristics](#) table.

Note: AUTOBALSWDIS affects cell-balancing switch behavior in manual Cell-Balancing modes only.

Note: The cell-balancing timer incrementing/expiration behavior is not affected by the AUTOBALSWDIS setting.

Manual Cell-Balancing Mode with FlexPack

During manual cell balancing, the top two consecutive cells should not be enabled for manual cell balancing. This creates a situation where SW_{TOPCELL1/2}, SW_{TOPCELL1}, and SW_{TOPCELL2} could potentially all be 5V below the TOPCELL1/2 cell input voltage. Although, the MAX17853 digital logic does not prevent users from using such a configuration, ALRTHVUV is expected to trip and the TOPCELL1/2 cell input measurements will not be valid.

Auto-Individual Mode

Auto-individual mode performs cell balancing in a controlled manner so that the cells can be individually discharged for a duration and/or to a specific voltage level, as required in the end application. The host initiates an auto-individual mode by setting CBMODE to 0b100 (duration is seconds) or 0b101 (duration in minutes), configuring CBEXPn to the desired value (where the LSB = 1 second or minute, respectively), and setting individual BALSWE_n bits, a group voltage target can also be set using CBUVTHR.

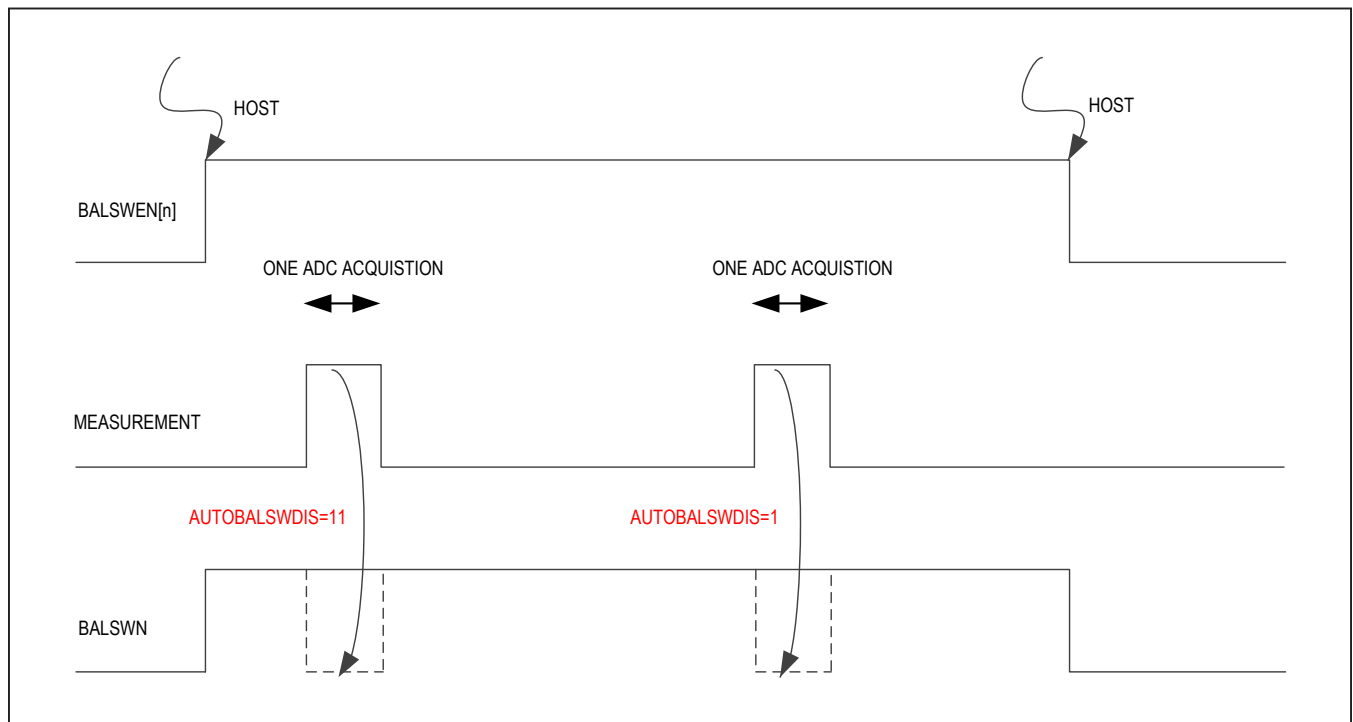

Figure 40. Logic Diagram when Balancing Switches are Disabled

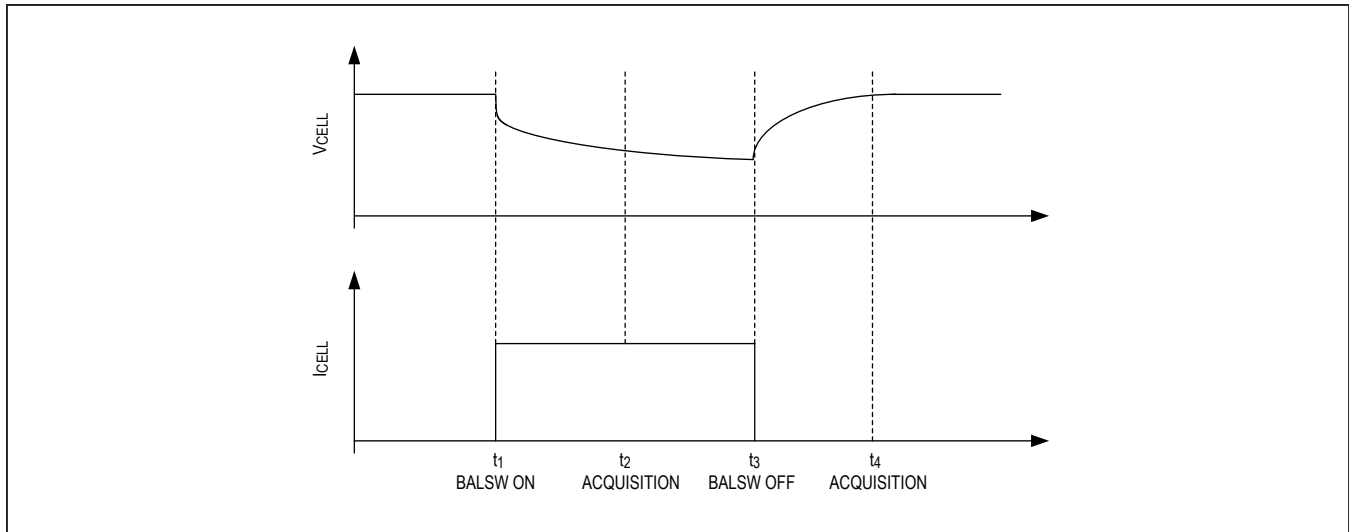

Figure 41. AUTOBALSWDIS Measurement Settling

In auto-individual mode, the balancing switches defined by $BALSWEN[n]$ are automatically controlled through non-overlapping even/odd cycling in accordance with the programmable timer duration ($CBEXPn$) and/or the under-voltage threshold ($CBUVTHR$). The balancing switch duty cycle can further be controlled using $CBDUTY$ to programmatically set the average balancing current. This is indicated below:

Even Cells (2, 4, ... 14):

$$BALSWn = BALSWEN[n] \& (CBTIMER \leq CBEXPn) \& CBEVEN \& (((CBMEASEN == 0b11) \& (CELLn \geq CBUVTHR)) | (CBMEASEN != 0b11))$$

Odd Cells (1, 3, ... 13):

$$BALSWn = BALSWEN[n] \& (CBTIMER \leq CBEXPn) \& CBODD \& (((CBMEASEN == 0b11) \& (CELLn \geq CBUVTHR)) | (CBMEASEN != 0b11))$$

$CBUVTHR$ exit settings apply, and ADC measurement and calibration operations can be performed if enabled to support host-controller readback.

$CBTIMER$ is incremented on a duty-cycled basis, indicating the time each channel is subject to discharge (i.e., one t_{CBE0} cycle out of each E/O/M discharge cycle). In real time, this means the discharge operation always runs at least 2x the maximum value set in $CBEXPn$. As an example, if both an even and odd cell must be balanced

for 1 hour and the $CBDUTY=100\%$, the associated timers would be set accordingly and the operation would last for ~2 hours (accounting for non-overlap timing). If the $CBDUTY$ is now set to 50% with the same timer settings, the total operation time would extend to ~4 hours.

The read-only counter ($CBCNTR$) increments at a 1Hz rate with periodic rollover at 0b11. The host can read this counter periodically to confirm the auto-individual mode is active.

$SHDNL$ operation can be controlled by $HOLDSDNL$, preventing device shutdown during auto-individual mode in case of an extended lapse in host communication.

Once initiated, auto-individual mode normally continues to run until $CBTIMER$ reaches max ($CBEXPn$) or all cells reach the voltage $CBUVTHR$ (whichever comes first, depending on configuration settings), and at this point, balancing-switch operations cease and $CBACTIVE$ is set to 0b10, indicating a normal exit condition. Cell balancing checks that thermal, calibration, and watchdog faults apply if enabled; if any of these conditions occur, switching activity is immediately halted and $CBACTIVE$ is set to 0b11, notifying the μC of the result. The cell balancing timer ($CBTIMER$) continues to run until expiration ($CBEXPn$), and $HOLDSDNL$ extensions are supported (if enabled). This allows the μC to confirm the exit condition.

Auto-Group Mode

The auto-group mode performs cell balancing in a controlled manner so that the cells can be discharged as a group for a duration and/or to a specific voltage level, as required in the end application. The host initiates auto-group mode by setting CBMODE to 0b110 (duration is seconds) or 0b111 (duration in minutes), configuring CBEXP1 to the desired value (where the LSB = 1 second or minute, respectively), and setting individual BALSWE_n bits. A group voltage target can also be set using CBUVTHR.

In auto-group mode, the balancing switches defined by BALSWE_n[n] are automatically controlled through non-overlapping even/odd cycling in accordance with the programmable timer duration (CBEXP1) and/or the under-voltage threshold (CBUVTHR). The balancing-switch duty cycle can further be controlled using CBDUTY to programmatically set the average balancing current. This is indicated as follows:

Even Cells (2, 4, ... 14):

$$\text{BALSWE}_n = \text{BALSWE}_n[n] \ \& \ (\text{CBTIMER} \leq \text{CBEXP1}) \ \& \ \text{CBEVEN} \ \& \ (((\text{CBMEASEN} == 0b11) \ \& \ (\text{CELL}_n \geq \text{CBUVTHR})) \ | \ (\text{CBMEASEN} != 0b11))$$

Odd Cells (1, 3, ... 13):

$$\text{BALSWE}_n = \text{BALSWE}_n[n] \ \& \ (\text{CBTIMER} \leq \text{CBEXP1}) \ \& \ \text{CBODD} \ \& \ (((\text{CBMEASEN} == 0b11) \ \& \ (\text{CELL}_n \geq \text{CBUVTHR})) \ | \ (\text{CBMEASEN} != 0b11))$$

Auto-group modes are identical to auto-individual modes except all timer durations are checked against CBEXP1 (a single-expiration event).

Emergency-Discharge Mode

Emergency-Discharge mode performs cell balancing in a controlled manner so that the cells can be discharged in the event of an emergency or battery end-of-life.

The host initiates the Emergency-Discharge mode by setting CBMODE to 0b001, configures CBEXP1 to the desired value (where the LSB = 1 hour). After Emergency-Discharge mode is activated, battery cells are discharged until CBTIMER expires or CBMODE is set to 0b000 (disabled).

In Emergency-Discharge mode, all balance switches (BALSWE_n) are enabled regardless of the BALSWE_n[n] settings, with a CBTIMER duration set by CBEXP1, and governed by non-overlapping even/odd cycling, as follows:

Even Cells (2, 4, ... 14):

$$\text{BALSWE}_n = (\text{CBTIMER} \leq \text{CBEXP1}) \ \& \ \text{CBEVEN}$$

Odd Cells (1, 3, ... 13):

$$\text{BALSWE}_n = (\text{CBTIMER} \leq \text{CBEXP1}) \ \& \ \text{CBODD}$$

CBUVTHR exit settings do not apply, but ADC measurement and calibration operations can still be performed if enabled to support host-controller readback.

CBTIMER is incremented on a duty-cycled basis indicating the time each channel is subject to discharge (i.e., one t_{CBE0} cycle out of each E/O/M discharge cycle). In real time, this means the discharge operation always runs at least 2x the maximum value set in CBEXP1. As an example, if both an even and odd cells must be balanced for 1 hour and the CBDUTY=100% the associated timers would be set to 0x3C and the operation would last for ~2 hours (accounting for non-overlap timing). If the CBDUTY is now set to 50% with the same timer setting, the total operation time would extend to ~4 hours.

The read-only counter (CBCNTR) increments at a 1Hz rate with periodic rollover at 0b11. The host can read this counter periodically to confirm that Emergency-Discharge mode is active.

SHDNL operation can be controlled by HOLDSHDNL, preventing device shutdown during Emergency-Discharge mode due to the extended lapse in host communication.

Once initiated, Emergency-Discharge mode normally continues to run until CBTIMER reaches CBEXP1. At this point, balancing-switch operations cease and CBACTIVE is set to 0b10, indicating a normal exit condition. Cell-balancing checks if thermal, calibration, and watchdog faults apply, if enabled. If any of these conditions occur, switching activity is immediately halted and CBACTIVE is set to 0b11, notifying the μC of the result. The cell-balancing timer (CBTIMER) continues to run until expiration (CBEXP_n), and HOLDSHDNL extensions are supported (if enabled). This allows the μC to confirm the abnormal exit condition.

Cell-Balancing Modes Summary

Table 32 summarizes the Cell-Balancing modes supported by the MAX17853.

Auto-Even/Odd Cell Balancing

Auto-even/odd cell balancing controls the enabling of adjacent balancing switches automatically with timing resolution from 1s to 1hr depending on the CBMODE configuration. This ensures that even or odd switches are not enabled simultaneously, while balancing equally within the balancing period. This allows the host to program the BALSLEN bit once without having to adjust the balance switches or timer period, which can be beneficial during system low-power operational modes where the host controller is asleep.

To prevent simultaneous channel conduction, a non-overlap period ($t_{\text{NONOVERLAP}} = 1\mu\text{s}$) is inserted between disabling one switch and enabling the adjacent switch. When the UV threshold is disabled, the total cell-balancing period is $(t_{\text{CBEO}} + t_{\text{NONOVERLAP}}) \times 2$. When the UV threshold is enabled, the cell-balancing period is increased by the ADC measurement time ($t_{\text{MEASUREMENT}}$). In this case, the total cell-balancing period is $(t_{\text{CBEO}} + t_{\text{NONOVERLAP}}) \times 2 + t_{\text{MEASUREMENT}}$.

Note: $t_{\text{CBEO}} = 1/2 \times$ timer resolution

The measurement time ($t_{\text{MEASUREMENT}}$) includes the cell-balancing path recovery-delay selection (CELLDLY) and a user-programmable delay determined by the external application circuit, which is imposed after each pair of even/odd discharge cycles. The other component to the measurement time includes the physical time for ADC acquisition, as defined in the SCANCTRL register (OVSAMPL in Cell-Balancing mode is non-programmable and fixed at 16 to ensure the highest accuracy measurements).

Note: CELLDLY is used in manual Cell-Balancing mode when using AUTOBALSWDIS=0b1 and ALTMUXSEL=0b0. Also used in automated cell-balancing and discharge modes after each pair of even/odd discharge cycles.

CBMODE=0x4, CBUVTHR=0x3FF

CMODE=5h, FLXPACK1/2=1, TOPCELL1/2=ODD

Note: Figure 42 and Figure 43 are not drawn to exact timescale; some sections have been exaggerated for visibility.

See the [Cell-Balancing UV Detection](#) section for further details and recommendations for embedded measurements during cell balancing.

Table 32. Cell-Balancing Mode

CBMODE[2:0]	DESCRIPTION	CBEXP[9:0]	TIMER RESOLUTION	T_{CBEO}	RANGE OF CBEXP[9:0]	
					MINIMUM	MAXIMUM
000b	Cell Balancing Disabled	000h	—	—	—	
001b	Emergency/EOL Discharge by Hour	001h to 3FFh	1hr	0.5min	1hr	1022hrs
010b	Manual-Cell Balancing by Second	001h to 3FFh	1s	—	1s	1022s
011b	Manual-Cell Balancing by Minute	001h to 3FFh	1min	—	1min	1022mins
100b	Auto-Individual Cell Balancing by Second	001h to 3FFh	1s	0.5s	1s	1022s
101b	Auto-Individual Cell Balancing by Minute	001h to 3FFh	1min	0.5min	1min	1022mins
110b	Auto-Group Cell Balancing by Second	001h to 3FFh	1s	0.5s	1s	1022s
111b	Auto-Group Cell Balancing by Minute	001h to 3FFh	1min	0.5min	1min	1022mins

Note: t_{CBEO} is the effective time that the even or odd switches are balanced within the timer resolutions.

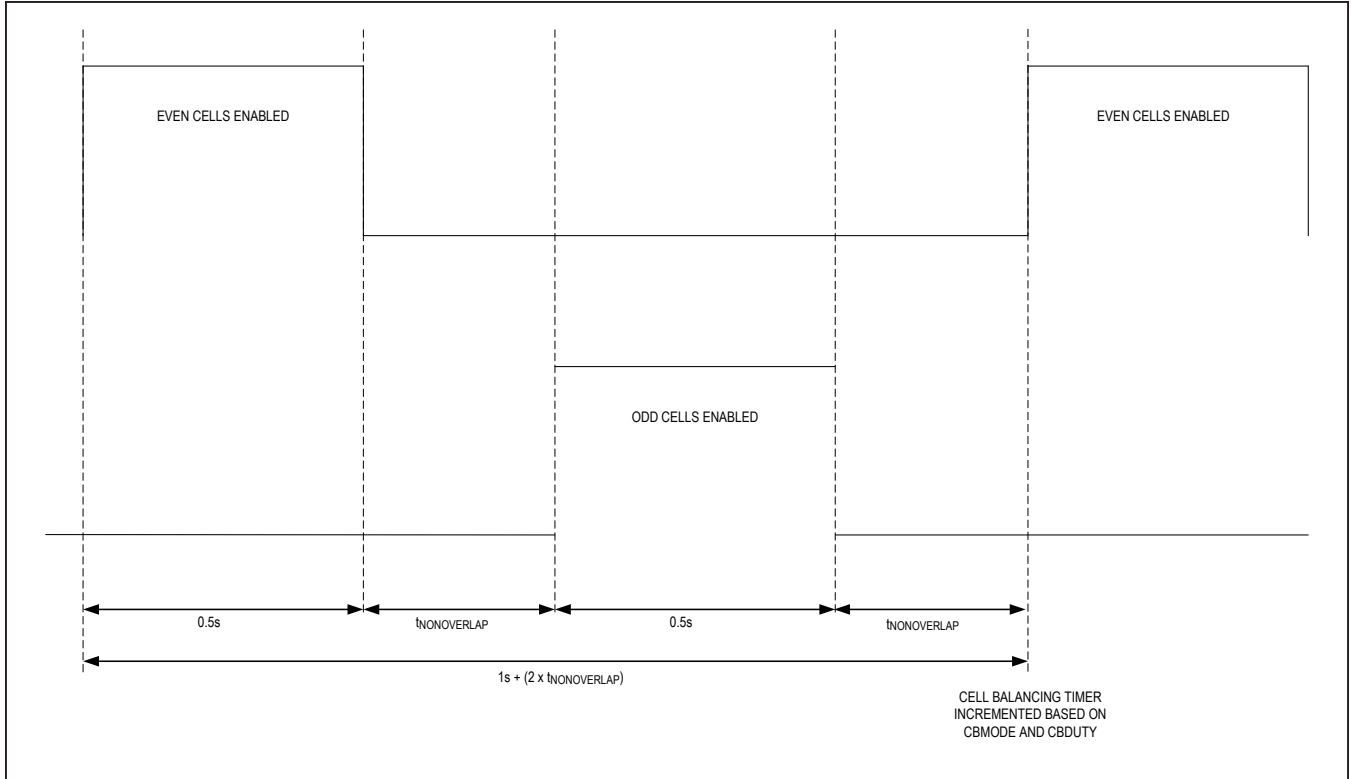

Figure 42. Auto Even/Odd Cell Balancing without UV Detection

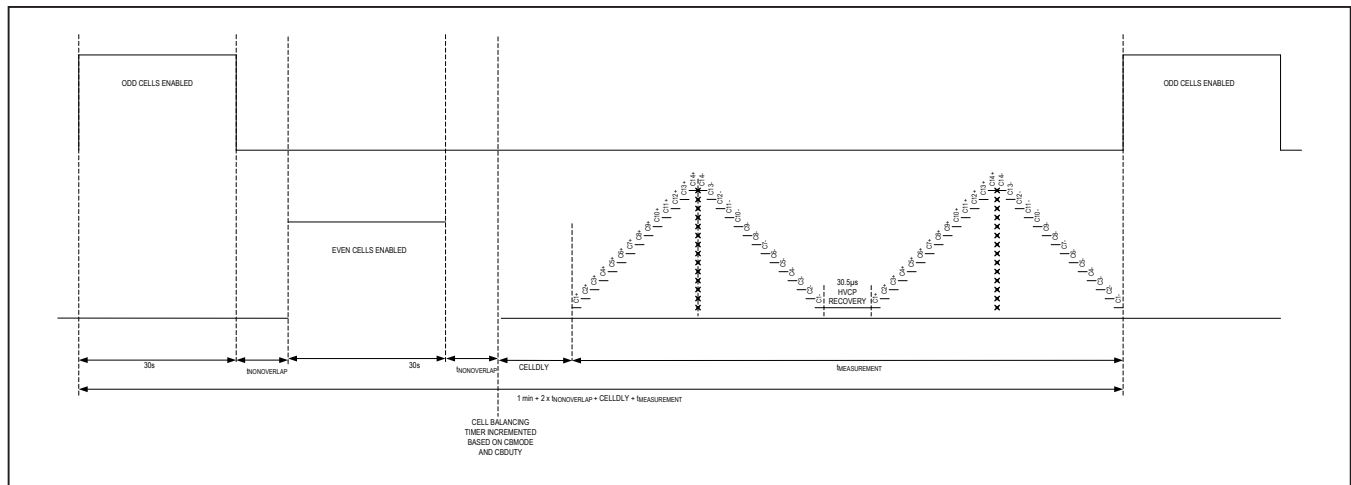

Figure 43. Auto Even/Odd Cell Balancing with UV Detection, ADC with OVSAMPL

Cell-Balancing Timer (CBTIMER)

Manual, Emergency Discharge, and Auto Group Mode

Timing: In manual, emergency discharge, and auto-group modes, the CBEXP1 bitfield within the BAEXP1 register is used as the cell-balancing timer duration setting. The duration can be configured from 1 to 1023 seconds, 1 to 1023 minutes, or 1 to 1023 hours depending on the CBMODE setting (LSB = hour, minute, or second). A value of 0x3FF allows the switches to be enabled indefinitely for CELLn if BALSWEENn is also enabled (CBTIMER mube active, and rollover at 3FFh, but is not checked against CBEXP1). In manual, emergency discharge, and auto- group modes, the 10-bit timer (CBTIMER) counts up until it reaches the duration set by BAEXP1. When the cell-balancing timer expires, all cell-balancing switches are disabled.

When CBEXP1 is non-zero, the cell-balancing timer (CBTIMER) runs and any requested measurement and calibration operations are performed until expiration, even if BALSWEEN[14:1]=000h (i.e., no balancing switches are actually activated), this ensures the μ C can still access the device to confirm balancing-operation progress and exit status.

A value of CBEXP1=000h ensure no cell balancing occur. For safety concerns, all BAEXPn are defaulted to 0x000, which ensures no cell balancing occurs without prior configuration.

Auto-Individual-Mode Timing: In auto-individual mode, the CBEXPn bits within the BAEXPn registers are used as individual cell-balancing duration times for each corresponding CELLn. Individual durations can be configured from 1 to 1023 seconds, or 1 to 1023 minutes depending on the CBMODE setting (LSB = minute, or second). A value of 0x3FF allows the switches to be enabled indefinitely for CELLn if BALSWEENn is also enabled (CBTIMER active and rollover at 3FFh, but is not checked against CBEXPn). The 10-bit expiration timer (CBTIMER) counts up until it reaches the maximum CBEXPn timeout value in the register block (regardless of the BALSWEENn settings), governing the balancing operations of all balancing switches. When an individual cell expiration time is reached (determined by CBEXPn), the CELLn switch is disabled going forward.

When any CBEXPn is non-zero, the cell-balancing timer runs and any requested measurement and calibration operations are performed until expiration, even if BALSWEEN[14:1]=000h (i.e., no balancing switches are actually activated). This ensures that the μ C can still access the device to confirm balancing-operation progress and exit status.

If all 14 CBEXPn settings are 000h, no cell balancing occurs for the switches.

General Timing and Safety Features (All Modes): For safety concerns, all BAEXPn are defaulted to 0x000, which ensures no cell balancing occurs without prior configuration.

The CBTIMER runs to expiration, even if the active cell balancing is halted due to UV- or thermal-exit conditions, which that the μ C can still access the part to confirm balancing-operation progress and exit status. If an extended SHDNL hold time is requested (HOLDSHDNL=1x), CBTIMER reads back the governing CBEXP time for the duration of the extended hold interval, allowing the μ C to confirm that the requested balancing operation has run to completion.

CBRESTART Usage in Manual Mode

The CBRESTART bit within the BALSWECTRL register must periodically be written to a 1 to restart the watchdog timer and prevent the cell balancing switches from being automatically disabled due to exiting Manual mode when CBTIMER reaches CBEXP1. In the event that a host fails to write the CBRESTART bit or forgets to disable the cell balancing switches, the cell balancing watchdog can automatically disable all cell balancing switches regardless of the BALSWEEN configuration. The cell balancing watchdog does not modify the contents of the BALSWEEN bits within the BALSWECTRL register.

The CBRESTART bit is used in Manual Cell-Balancing mode only. It provides a means to select new BALSWE settings and refresh the Watchdog timer with a single command.

This bit is ignored and has no effect outside of an active Manual Cell-Balancing operation. If a Manual operation was selected and the timer is allowed to expire, the operation must be relaunched with a write to BALCTRL (i.e., CBRESTART will not reinitiate a Manual operation that has allowed the CBTIMER to expire).

Emergency-Discharge Mode and CBDUTY Behavior

In Emergency-Discharge mode, the CBTIMER is incremented on a duty-cycled basis, indicating the effective time on each channel is subject to discharge. Since the active duty cycle within each 30s t_{CBEO} period is specified by the CBDUTY register, the CBTIMER is incremented at specified fractions of 30s (see [Table 33](#)).

For example, when CBDUTY is set to 1hr, CBTIMER is incremented in 3.750s steps at the end of the E/O/M cycle.

Notification Alerts Using CBNTFYCFG

In automatic and discharge modes, the cell-balancing notification alert (ALRTCBNTFY) can be issued to confirm normal progression of automated operations. The frequency of issuance is 1 hour, 2 hours, or 4 hours, in real time (i.e., not CBDUTY adjusted). Notification alerts continue to be issued during HOLDSDNL extension periods.

Cell-Balancing Expiration Timer Summary

In summary, the implementation of the CBTIMER is shown in [Figure 44](#).

Table 33. Emergency-Discharge Mode

FUNCTION	REGISTER FIELD	CONFIGURATION	BEHAVIOR
Emergency-discharge duty cycle	CBDUTY[3:0]	0x0	Switches on for 6.25% for 30s (1.875s per 30s)
		0x1	Switches on for 12.5% for 30s (3.750s per 30s)
	
		0xF	Switches on for 100% for 30s (less $t_{NONOVERLAP}$)

Note: It is recommended to design the external balancing current at 100% duty-cycle operation to avoid potential thermal issues.

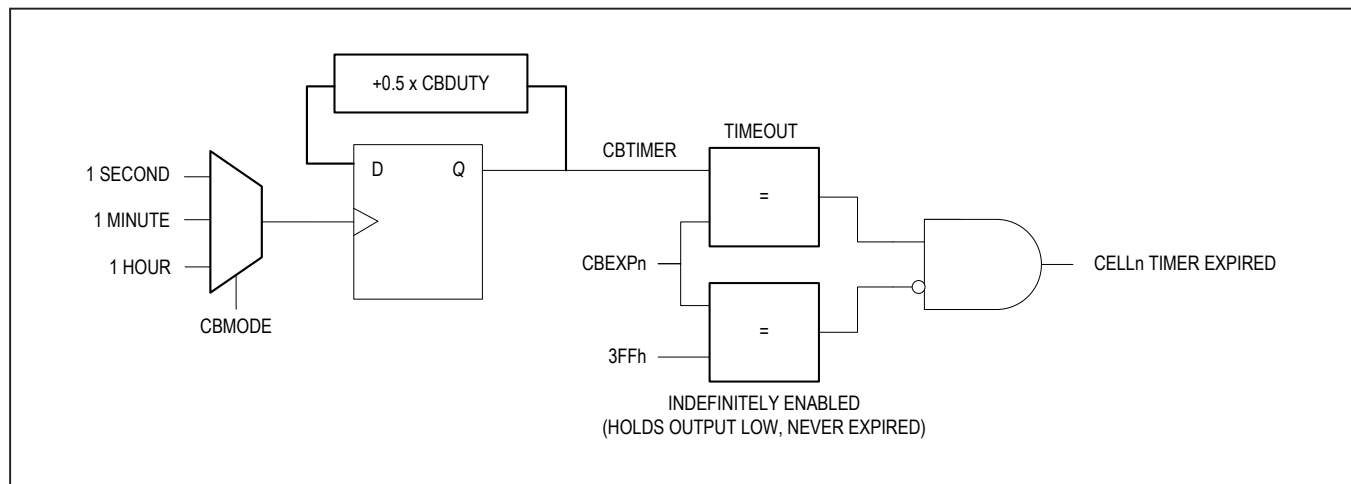

Figure 44. Cell-Balancing Expiration Timer

Note: The CELLn time-expired output feeds into the cell-balancing stop control logic.

Cell-Balancing UV Detection

Cell balancing to a UV threshold allows for all enabled cells configured by BALSWEN to be individually balanced to a specified and uniform voltage level, as shown in [Figure 45](#). When a cell reaches the UV threshold, the corresponding balance switch is disabled and remains in an idle state until reinitialized by the host.

Automated-cell balancing with CBUVTHR checking is only supported for unipolar cell measurements in locations with BALSWENn=0b1. The user must also ensure CELLENn=0b1 and POLARITYn=0b0 to allow the required measurement updates; if the measurement is not supported, balancing of the cell automatically ends with a CBUVSTATn=0b1 exit condition.

CBUVSTATn in the BALUVSTAT register indicates the corresponding CELLn+1 result falls below the threshold specified by CBUVTHR and that cell-balancing operations on that cell have ended. CBUVSTAT[n] is only cleared when CBMODE is written to 0b000 (disabled) or when a new CBMODE operation is initiated through BALCTRL.

Automated-cell balancing to a UV threshold is configured by setting the CBMEASEN bits within the BALCTRL register to 0b11. The UV threshold can be used independently or along side the cell-balancing timer(s) (CBEXP1 or CBEXPn). In the case where a timer is programmed, it serves as a redundant mechanism to ensure that a cell is not over-discharged. When all cells have reached the UV threshold, all cell-balancing switches will be disabled but the cell-balancing timer runs until completion; this ensures that the μ C can still access the device to confirm balancing-operation progress and exit status. To use a defined UV threshold, the threshold level must be written

to the CBUVTHR in the BALAUTOUVTHR register. This register allows for 14-bit values relating to a 305 μ V LSB.

Optionally, the MINCELL value from the prior ADC acquisition can be used as the the desired threshold value. When CBUVMINCELL is disabled, the value written to CBUVTHR during a valid write to BALAUTOUVTHR be loaded to CBUVTHR. When CBUVMINCELL is enabled the current value in the CELL[n] register corresponding to the MINCELL address be automatically loaded to CBUVTHR during a valid write to BALAUTOUVTHR (and the content in CBUVTHR during the write be ignored). When the BALAUTOUVTHR register is read back, the current value of CBUVTHR be provided, with CBUVMINCELL indicating the means by which it was selected.

The HVMUX and ADC signal chain is used for the balancing measurement and threshold comparison. The acquisition is determined by the channels enabled in the BALSWEN bitfield as well as the parameters set in the SCANCTRL register. The achievable accuracy of the UV measurement will be determined by ADC accuracy specifications in the electrical characteristics. For the highest accuracy, calibration should be asserted prior to initiating balancing.

Note: CELL_A, CELL_B, CELL_C, and CELL_D are non-specific cells. CELL_A represents the cell with the lowest starting voltage. CELL_D represents the cell with the highest starting voltage. In this example, CBUVTHR is the UV threshold for all cells and CBEXP1 is the cell-balancing expiration timer for auto-group Cell-Balancing mode (CBMODE=0b11x). The CELL_N UV-threshold crossings are inputs to the cell-balancing stop control logic.

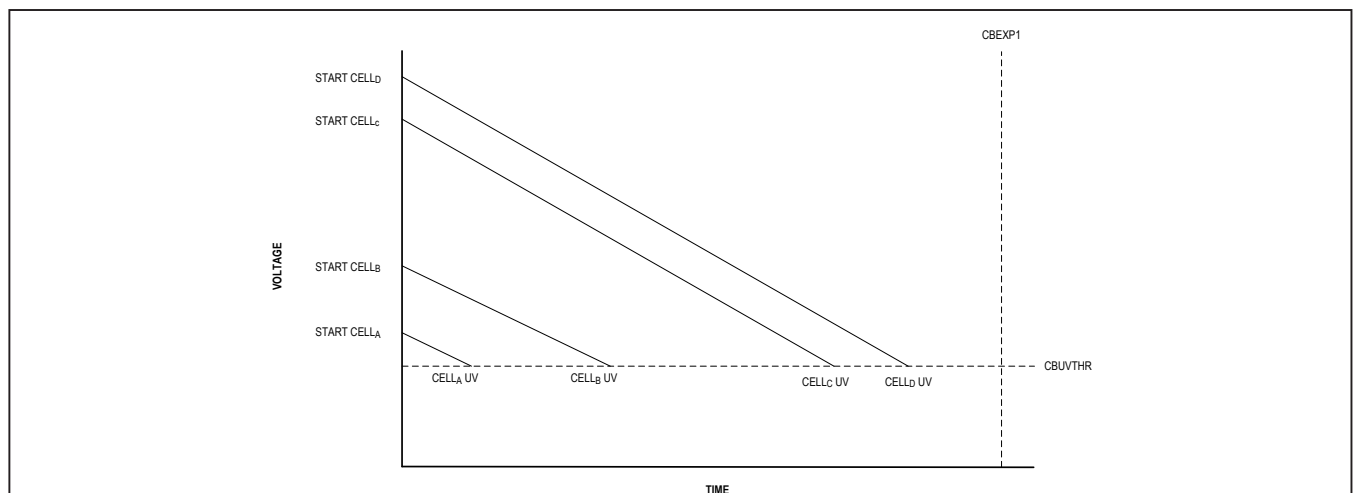

Figure 45. Cell-Balancing UV-Threshold Crossing

Cell-Balancing Measurement

Embedded cell-balancing measurements only occur when requested by CBMEASEN, as indicated in [Table 34](#).

CBMEASEN selections are only functional in discharge and automated Cell-Balancing modes; this setting is ignored in all other modes.

Measurements are taken using the ADC with a fixed OVSAMPL=16x, SCANMODE='pyramid' to provide the highest accuracy measurements. All other scan parameters will be set according the current SCANCTRL, ACQCFG, DIAGCFG, and POLARITYCTRL registers. Any attempt to overwrite the scan parameters during balancing be ignored and an ALRTRJCT condition be issued.

Cell-Balancing IIR Filtering

In auto-discharge and automated Cell-Balancing modes, the automated ADC measurements are processed through each of the individual cellss' IIR filter. This filter allows for more accurate measurements and provides noise immunity to maintain robust balancing performance.

In these modes, the IIR filter maintains the setting configured by the user, if enabled (IIRFC!=0b111). In the event that the IIR is not used in the normal application (IIRFC=0b111 = 8/8), the IIR filter will be enabled with an equivalent IIRFC=0b000 = 1/8 for use in debouncing measurements.

Additionally, if the IIR filter is not used in normal applications or has not been routinely updated using AMENDFILT,

the CBIIRINIT bit should be used to initialize the IIR with the first acquisition's measurements to avoid falsely exiting the UV threshold due to the long settling response. How the filter behaves upon entry into an automatic or emergency-discharge Cell-Balancing mode thus depends on the CBIIRINIT setting:

In continuation mode (CBIIRINIT=0), the current value in the IIR accumulators are kept (presumably from previous cell measurements), and cell-balancing measurements amended normally.

In initialization mode (CBIIRINIT=1), the IIR accumulators are reinitialized to the first measurement taken, and further cell-balancing measurements are amended normally. CBUVTHR checking will not be enabled after the 16th measurement is taken (checking begins on the 17th measurement) which gives the IIR time to settle.

Cell-Balancing Calibration

In automated and discharge modes, after each pair of even/odd cell-balancing periods, a supervisory ADC measurement can be taken (and checked against CBUVTHR, if enabled/applicable, see CBMEASEN). Due to the expected temperature rise during cell balancing, it is recommended to allow automated-calibration sequences to be interleaved with the measurement acquisitions. This is done by programming the CBCALDLY to a non-zero value, which signifies how many measurement cycles are taken prior to a calibration being taken (see [Table 35](#))

Table 34. Cell-Balancing Measurement Enable

CBMEASEN[1:0]	DESCRIPTION
0b0x	Provides the highest duty cycling by skipping all measurement operations. Only cell-balancing timer(s) are used to terminate cell balancing normally.
0b1x	Enables embedded measurements for manual UV monitoring or supervision by the host processor.
0b11	Enables embedded measurements and internal CBUVTHR checks in automated modes (checking is not supported in Emergency-Discharge mode).

Table 35. Cell-Balancing Calibration Selection

ADCCALEN (APPLY CALIBRATION)	CBCALDLY (PERFORM CALIBRATION)	RESULTING OPERATION
1 (ON)	Non-Zero (ON)	ADC results are post-processed based on calibration coefficients obtained periodically during the cell-balancing operation.
1 (ON)	000 (OFF)	ADC results are post-processed based on calibration coefficients obtained prior to the cell-balancing operation.
0 (OFF)	Non-Zero (ON)	Calibration is performed during the cell-balancing operation, but ADC results are based on factory defaults (not recommended).
0 (OFF)	000 (OFF)	ADC results are based on factory defaults.

The CBCALDLY settings are only functional if CBMEASEN=0b1x (cell-balancing measurements are requested); otherwise they are ignored.

A value of 0x00 (default) in the CBCALDLY bits within the BALDLYCTRL register disables CAL operations (only ADC measurement operations are performed).

If a non-zero value is selected, the first ADC measurement (ADC) operation is replaced with an on-demand calibration (CAL) operation. From that point on, this selection determines how often the ADC operation is automatically replaced with a CAL operation (to address thermal drift due to power dissipation during cell balancing). 0b001 means ADC and CAL alternate every other cycle. 0b010 means a CAL occurs once every four cycles. 0b111 (maximum setting) means a CAL occurs once every 32 cycles. See Table 36 for a list of all possible settings .

Calibration Out-of-Range During Cell Balancing

After a measurement or calibration is completed, the cell balancer checks the status of the ALRTCAL register bit to see if calibration is enabled (ADCCALEN=1). If ALRTCAL is set, it indicates that calibration is out-of-range, and that calibrated ADC results could be corrupted as a result.

Table 36. Calibration Frequency

CBCALDLY	CALIBRATION FREQUENCY
0b000	Periodic Calibration Disabled
0b001	2 cycles
0b010	4 cycles
0b011	8 cycles
0b100	12 cycles
0b101	16 cycles
0b110	24 cycles
0b111	32 cycles

If ALRTCAL is set and calibration is enabled (ADCCALEN=1), the ALRTCBCAL bit will be set and active cell-balancing operations immediately halted to prevent balancing errors due to inaccurate measurements. All subsequent measurements, calibration, and switching cycles are skipped until the cell-balancing duration expires, or is otherwise aborted/restarted. The cell-balancing timer (CBTIMER) continues to run until the governing CBEXP time is reached, and HOLDSHDNL extensions still apply (if enabled), allowing the μC to confirm exit status. Note that once ALRTCBCAL is issued, data in the CBUVSTAT bitfields and data fetched by CBSCAN requests should be considered compromised.

If an ALRTCAL/ALRTCBCAL condition is issued, the user can exit the cell-balancing operation, and attempt to resolve the condition. If the condition cannot be resolved, cell-balancing operations can be requested using factory-calibration defaults by setting ADCCALEN=0.

Transfer-Measurement Results Using CBSCAN

The CBSCAN bit in the BALDATA[7:0] register can initiate a manual transfer of results from the IIR to the CELLn data registers (RDFILT is ignored, and IIR data is always transferred, since the IIR governs cell-balancing operations). CBSCAN supports the readback of measurement results taken during automated and emergency-discharge Cell-Balancing modes. If CBSCAN is issued during these cell-balance measurements, the move will be executed once the sequence is completed.

CBSCAN acts as a strobe bit and therefore does not need to be cleared (self-clearing). Always reads logic zero.

CBSCAN is not valid outside an automated cell-balancing operation. If automated cell balancing is stopped, or when manual balancing is operational, the measurement scan bitfields in the SCANCTRL register must be used for data control in the CELLn registers.

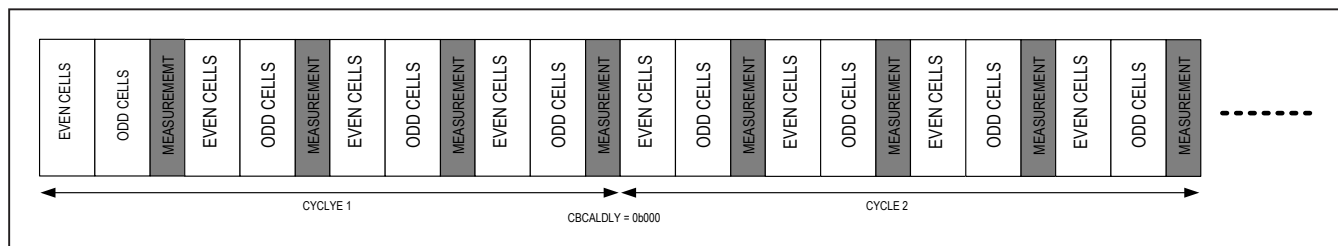

Figure 46. Cell Balancing with No Calibration

Cell Balancing with Calibration

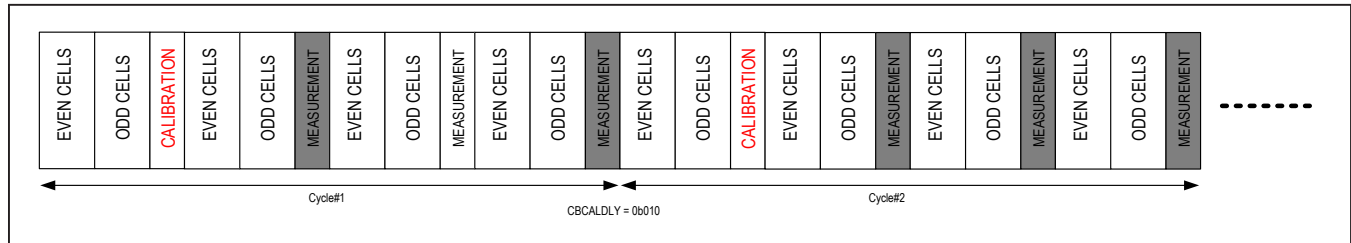

Figure 47. Cell Balancing with Calibration

Cell-Balancing Completion

In summary, after the host initializes the cell-balancing operation, the operation is stopped by any of the following:

- Watchdog-timer expiration (CBTIMER=CBEXPn)
- Reaching the UV threshold (per cell in automatic mode only, if CBMEASEN=0b11)
- Thermal-fault condition (automatic and discharge modes only, if CBTEMPEN=0b1)
- Calibration-fault condition (automatic and discharge modes only, if ADCCALEN=0b1)
- Aborting the operation by changing CBMODE to 0b000 (disabled)
- Re-initiating an operation by changing CBMODE to a value other than 0b000

Manual cell-balancing-mode switch activity can be temporarily suspended for calibration or ADC measurements if AUTOBALSWDIS=0b1.

In discharge, manual, and auto-group modes, the CBTIMER is stopped when it reaches CBEXP1, regardless of BALSWEEN settings.

In auto-individual modes, the CBTIMER is stopped when it reaches MAX(CBEXPn), regardless of BALSWEENn settings.

Automatic and discharge modes are halted if temperature exit is enabled (CBTEMPEN=0b1) and an overtemperature fault occurs.

Automatic and discharge modes are halted if (CBMEASEN=0b1x) and a calibration fault occurs.

All timed modes run CBTIMER for the full duration specified, even if actual cell-balancing operations are stopped due to UV or thermal-exit conditions, allowing the μC to confirm the exit status. Additional time for the μC to check exit status can be afforded using HOLDSHDNL options.

CBACTIVE allows confirmation of cell-balancing operation status. A cell-balancing operation is considered completed normally if the CBTIMER expires (all CB modes), or when all enabled cells reach the programmed CBUVTHR limit (automatic modes only, if CBMEASEN=1b1). A cell-balancing operation is considered completed abnormally in the event of an ALRTCBCAL or ALRTCTEMP condition.

Note: The thermal fault limits the temperature rise to a safe level below the maximum junction temperature of the device, as defined by the ALRTTEMP specification in the [Electrical Characteristics](#) table. For applications requiring maximum cell-balancing current, this can be disabled, but the system should take caution to ensure that the device is not damaged by exceeding the absolute maximum rated junction temperature.

Automatic SHDNL Control Using HOLDSHDNL

To allow for timed balancing with no host interaction, the SHDNL pin can be pulled up to V_{AA} to keep SHDNL high while the timers or UV detection is running, by appropriately configuring the HOLDSHDNL bitfield within the BALCTRL[15:8] register. When enabled and engaged, this mode activates an internal diode pullup from the V_{AA} pin to SHDNL. This keeps the device operational, even if UART operation is suspended for long periods of time.

The HOLDSHDNL options have no effect in disabled or manual modes.

In mode 0b01, the pullup will be engaged for the selected CBEXP1 interval for group operations, or the longest CBEXPn time selected for individual operations, even if switch activity is halted due to thermal protection (ALRTCTEMP), calibration issues (ALRTCBCAL), or reaching the specified voltage target (CBUVTHR).

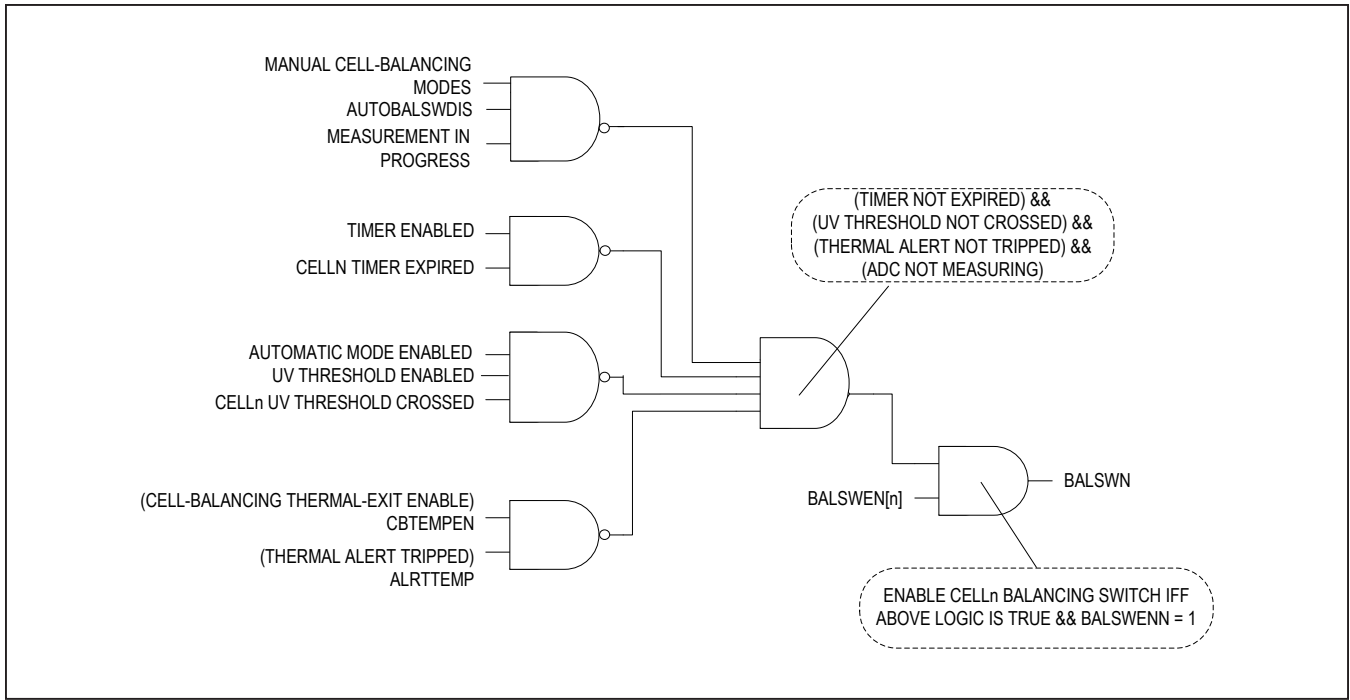

Figure 48. Cell-Balancing Stop Control

In mode 0b10, the pullup will be engaged for the selected CBEXP1 interval for group operations, or the longest CBEXPn time selected for individual operations, even if switch activity is halted due to thermal protection (ALRTCBCAL), calibration issues (ALRTCBCAL), or reaching the specified voltage target (CBUVTHR). After CBTIMER expires, HOLDSHDNL continues to be held for the larger of 5 minutes or 6.25% of the relevant CBEXPn interval. If CBEXPn timing is disabled/infinite (3FFh), SHDNL is held until removed by a write to BALCTRL.

In mode 0b11, the pullup will be engaged until removed by a write to BALCTRL.

If HOLDSHDNL=0b1x, CBTIMER reads back the governing CBEXP time for the duration of the extended hold interval, allowing the μ C to confirm the requested balancing operation has run to completion. In modes HOLDSHDNL=0b1x, the hold behavior can be removed after operations are completed and the exit status has been confirmed by writing CBMODE to disabled, allowing the device to power down.

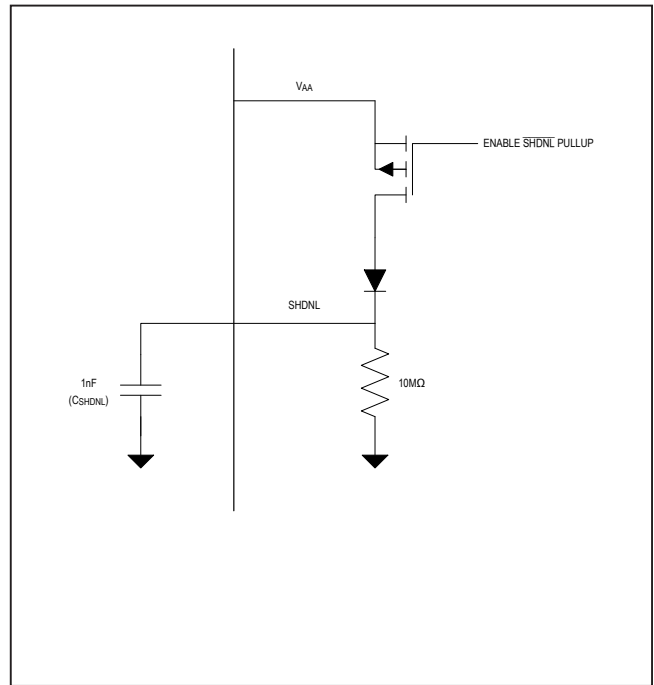

Figure 49. SHDNL Pullup Control

Cell-Balancing Switches

The cell-balancing current is limited by the external balancing resistance, $R_{BALANCE}$, and the internal balancing-switch resistance (R_{SW}). See Figure 50. Cell-balancing switches are internally controlled with even/odd switching sequences in auto/manual modes, or independently in Emergency-Discharge mode. Fault detection is described in the *Diagnostics* section.

Cell-Balancing Current

The cell-balancing current is limited by package power dissipation, average die temperature, average duty cycle, and the number of switches conducting current at any one time. The system designer must carefully control the device power dissipation by selecting a balancing current resistance ($R_{BALANCE}$) to ensure the die and package temperature are below the absolute maximum package rating and neither the device thermal-shutdown threshold or the ADC measurement accuracy is impacted. The maximum per-switch balancing current for seven switches concurrently enabled are shown in Figure 51 for an assumed 10-year device lifetime.

Example: Autonomous-Cell Balancing by Time

Autonomous-cell balancing can be commanded within the MAX17853 to enable balancing while the host micro-controller enters a sleep state. The following procedure illustrates how autonomous-cell balancing is invoked with the primary stop mechanism as a timer:

- 1) Host calculates SOC for each of the individual cells.
- 2) Host determines which cells to balance and the associated balancing time.
- 3) Host programs balancing channels using $BALSWEN[13:0]$.
- 4) Host programs effective balancing current.

$$\text{Effective balancing current} = \frac{V_{CELLn}}{(2 \times R_{BALANCE}) \times CBDUTY[7:4]}$$
- 5) Host programs $CBEXP1-CBEXP14$ based on the effective balancing current and SOC.
- 6) Host programs $HOLDSDHNL$ to determine shutdown behavior at completion of cell balancing.
- 7) Host initiates balancing using $CBMODE$ "auto-individual cell balancing by second" or "auto-individual cell balancing by minute."

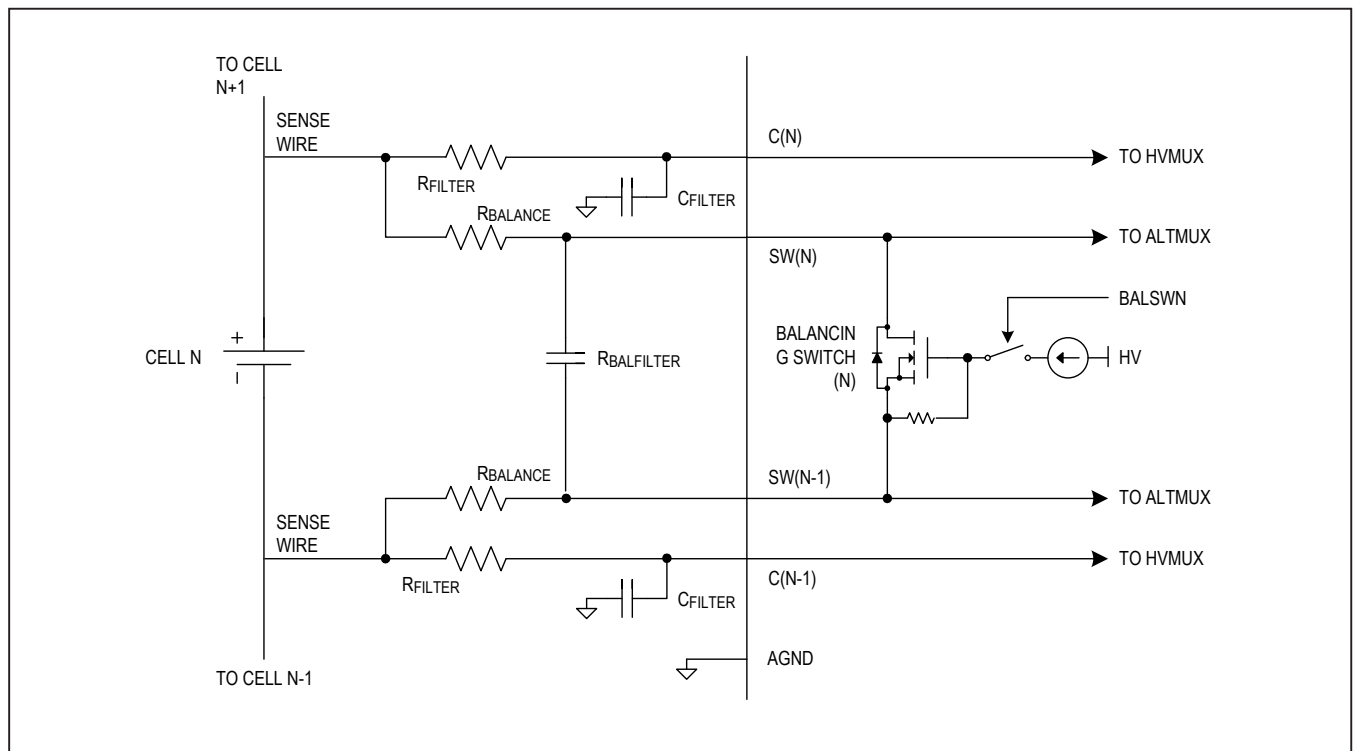

Figure 50. Internal Cell-Balancing Switches

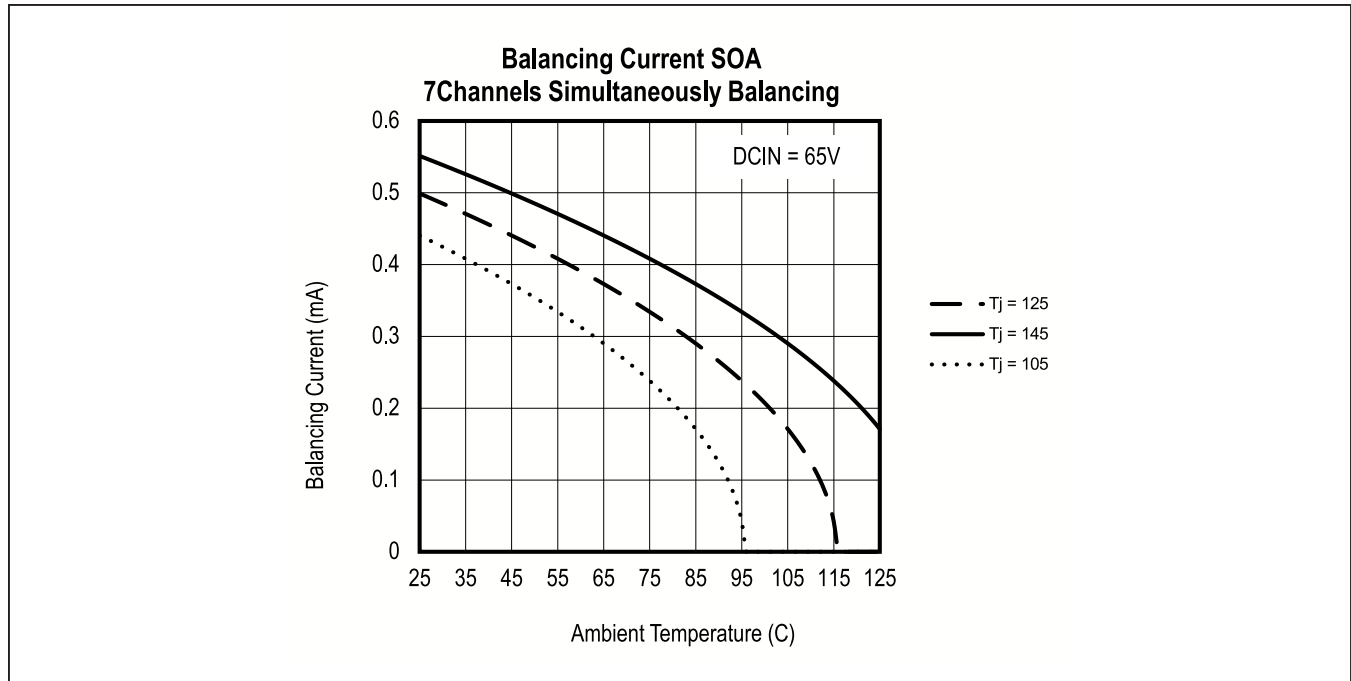

Figure 51. Typical Balancing-Current Performance

Example: Autonomous-Cell Balancing with Programmable UV Threshold

Autonomous-cell balancing controlled through programmable UV thresholds can be commanded within the MAX17853 to enable balancing while the host microcontroller enters a sleep state. The following procedure illustrates how balancing is invoked, with the primary stop mechanism configured as a voltage measurement and a secondary stop mechanism as a programmable timer.

- 1) Host calculates SOC for each of the individual cells.
- 2) Host determines which cells to balance and the associated balancing time:
Timer is a secondary stop mechanism and should have additional margin applied to not interact with primary UV measurement stop threshold.
- 3) Host programs balancing channels using BALSLEN[13:0].
- 4) Host programs effective balancing current:
Effective balancing current = $V_{CELLn} / (2 \times R_{BALANCE}) \times CBDUTY[7:4]$
- 5) Host programs CBEXP1–CBEXP14 based on the effective balancing current and balancing time calculation.
- 6) Host programs CBUVTHR or CBUVMINCELL to program the UV measurement stop threshold.
- 7) Host programs CBMEASEN as "embedded ADC/CAL measurements enabled, CBUVTHR checking enabled."
- 8) Host programs CBCALDLY to force measurement calibration to account for temperature rise from balancing
Calibration choice should be chosen based on the thermal time constant of the board.
- 9) Host programs HOLDSDNL shutdown behavior at completion of cell balancing
- 10) Host initiates balancing using CBMODE as "auto-individual cell balancing by second" or "auto-individual cell balancing by minute."

Interface

Interface Options

The MAX17853 supports two different interfaces to control the data-acquisition system. The applied interface is configured using the UARTSEL pin. Drive this pin externally by applying a pullup resistor to V_{AA} to enable UART, or a pulldown resistor to AGND to enable SPI. This interface flexibility allows one device to serve multiple battery applications for high-voltage and low-voltage systems, but it cannot dynamically change between them both.

UART Interface

The Battery-Management UART Protocol allows up to 32 devices to be independently addressed in a daisy-chain fashion, as shown in Figure 52. The host initiates all communication with the daisy-chained devices through a UART interface such as the MAX17841B. The UART can be configured to support a variety of flexible implementations depending on the application requirement. The configurations, as defined using UARTCFG, are shown in Table 37:

Single-UART Interface with External Loopback

When UARTCFG is configured for single-UART with external loopback, the data flow is always unidirectional from the host, up the daisy-chain (Up path), and then loops back down the daisy-chain (Down path) to the host, as shown in Figure 52.

In the Up path, each device first receives data at its lower Rx port and immediately retransmits data from its upper Tx port to the lower Rx port of the next device. The last device uses an external loopback-differential cable to transfer data from its upper Tx port directly into its upper Rx port, then immediately retransmits the data from its lower Tx port to the upper Rx port of the next down-stack device. The Down path then acts as a pass through, buffering and retransmitting the data. It does not act on any commands in this configuration.

The external loopback has two advantages, it is quicker to determine device count for applications where the host does not assume what the device count is, and it helps to match the supply current of the last device to that of the other daisy-chained devices (because the hardware configuration is identical).

Table 37. UART Configurations

UARTCFG	UART CONFIGURATION	UART UP PATH	UART DOWN PATH
0b00	Single-UART Interface with External Loopback	Active	Inactive (Buffered/Pass Through)
0b01	Single-UART Interface with Internal Loopback	Active	Inactive (Buffered/Pass Through)
0b10	Single-UART Interface with Differential Alert Interface	Active	Differential Alert
0b11	Dual-UART Interface	Active	Active

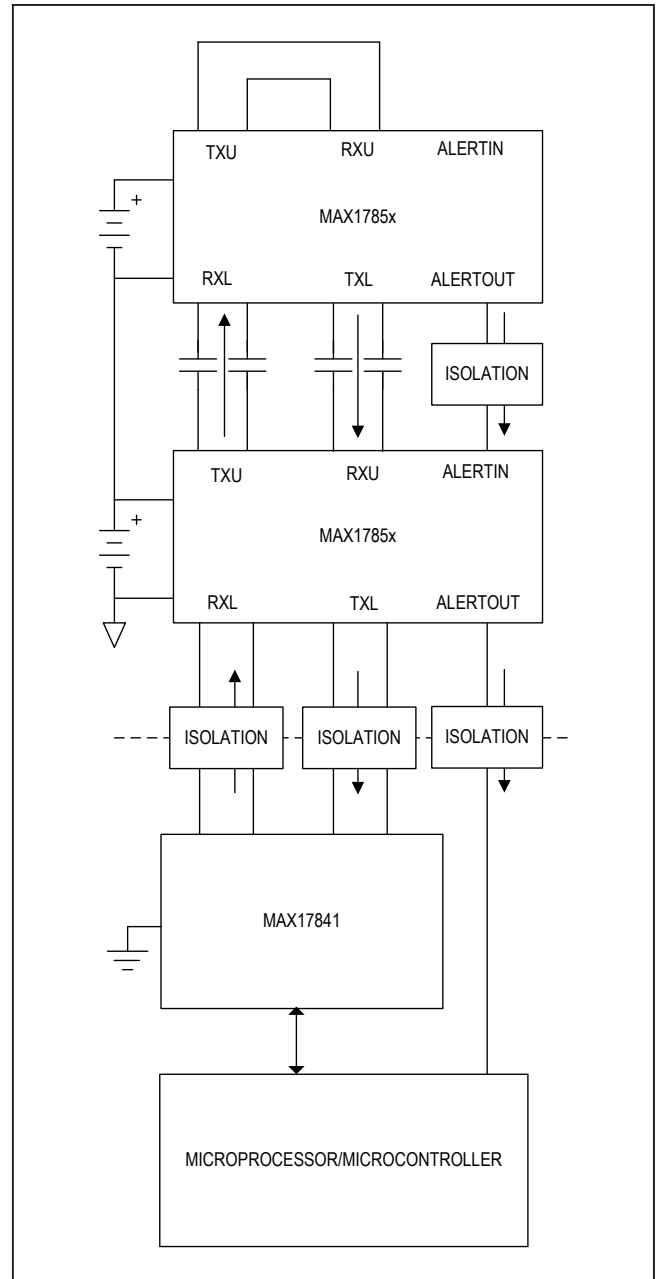

Figure 52. Single UART with External Loopback

Single UART with Internal Loopback

Single UART with internal loopback (UARTCFG=0b01) routes the upper-port transmit data internally to the upper-port receiver. This can be used to configure the top device in the daisy-chain to prevent the need for external components and wire connections. Additionally, this mode is useful to diagnose the location of any daisy-chain signal breaks. This is done by enabling the internal-loopback mode on the first device, checking communication, then moving the loopback mode to the next device and continuing up the stack until communication is lost.

Changing the UART configuration to single UART with internal loopback immediately changes that device's upper-port configuration so the signal is routed internally from the upper transmitter to the upper receiver, while external signals present on the upper-port receivers' input pins are ignored; therefore, when UARTCFG is written to 0b01, the WRITE command forwarded in the Up path is interrupted in the down-stack direction, interrupting its return to the host. To verify if the operation was successful, issue this command twice. If the MAX17841B interface is used, its receive buffer should be cleared before changing UARTCFG, and cleared again after changing the loopback configuration because the communication was interrupted.

Dual-UART Interface

If the end application requires higher data throughput or a redundant communication path for safety, a dual-UART-interface configuration can be utilized by writing UARTCFG=0b11. When configured, the Down path acts as an independent UART path that enables simultaneous read processing from both UART paths. This essentially doubles the effective interface rate to ~4Mbps. In the event of a broken interface wire, the independent UART paths allow uninterrupted access to all devices in the daisy-chain by dynamically changing the master interface with no loss of functionality.

Note: For this configuration to be utilized, both hardware and software configurations should match.

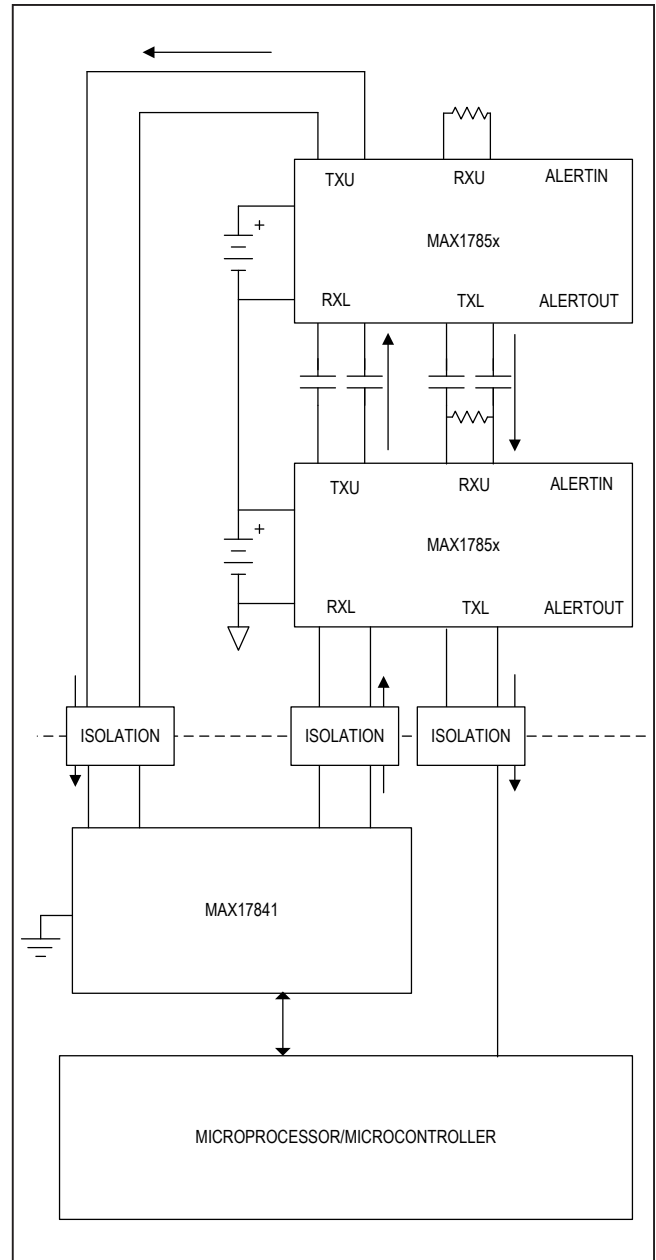

Figure 53. Single UART with Differential Alert Interface

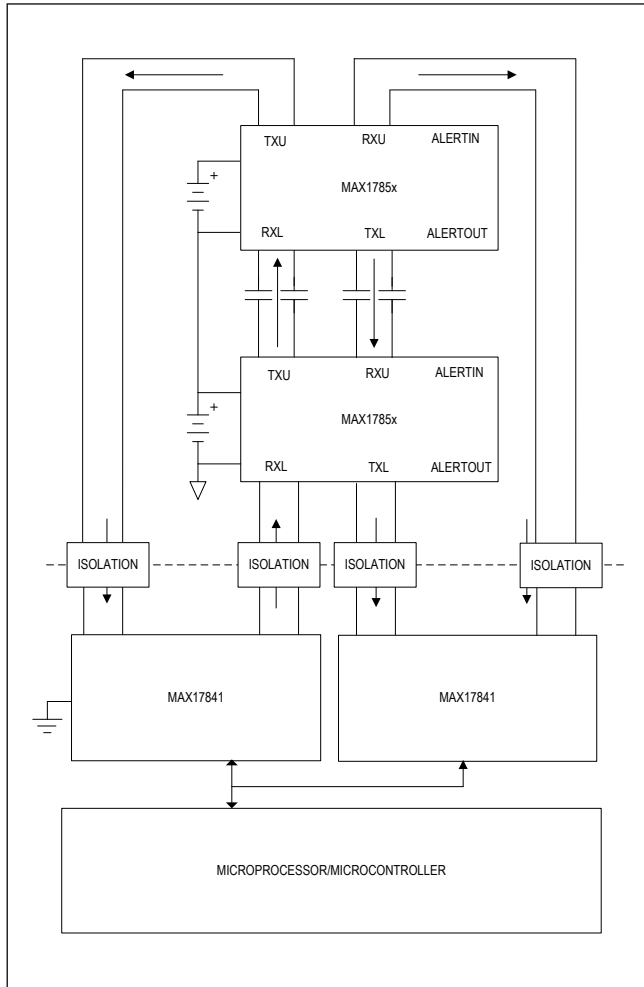

Figure 54. Dual-UART Interface

By default, the Down-path UART operates as a slave device and as such, has no response to a WRITE or WRITEALL command. The slave interface only responds to the READ, READALL, and READBLOCK commands. If a WRITE command is issued on the slave UART, the write is ignored and passed through to the next device in the daisy-chain, eventually returning to the MAX17841. Each device in the daisy-chain asserts its ALRTDUALUART bit in the STATUS2 register to indicate that a valid WRITE command was received but not acted upon. This bit remains set until cleared by the master interface.

Configuration of the master is performed using the UPHOST or DOWNHOST commands; identification of the master is performed by reading the UARTHOST bit. See the [Battery-Management UART Protocol Commands](#) section.

Dual-UART Master Configuration

If the upstream UART path cannot communicate due to a failure condition, the downstream UART path can reinitialize itself as the master through a DOWNHOST UART command packet issued by the host. This allows the downstream path to have full read and write capability. The upstream path then hands over master functionality and configures itself as a slave. If the upstream path regains functionality, it is able to only issue READ commands, unless it reinitializes itself as the master using the UPHOST command.

If an interface is reinitialized, the host should poll the UARTHOST bit to ensure that all devices within the daisy-chain are configured to the same master interface.

Note: The UPHOST command is only valid on the upstream UART and the DOWNHOST command is only valid on the downstream UART. If an UPHOST command

is issued on the downstream UART, no action is taken and the ALRTDUALUART bit will be set.

Dual-UART Master/Slave Interaction

The upstream and downstream UART timing should be synchronized by the host controller to avoid potentially reading data from the prior acquisition. This may occur when the master issues a WRITE command and the slave attempts to read the data before the entire data packet

propagates through the last device in the daisy-chain. See [Figure 55](#) and [Figure 56](#) for an example of the timing considerations. The master UART path will not prevent this interaction and should be handled by the host.

Similarly, the UPHOST and DOWNHOST commands should not be sent simultaneously to avoid an unknown state to the host controller. The host controller will not be able to diagnose the incorrect state by reading the

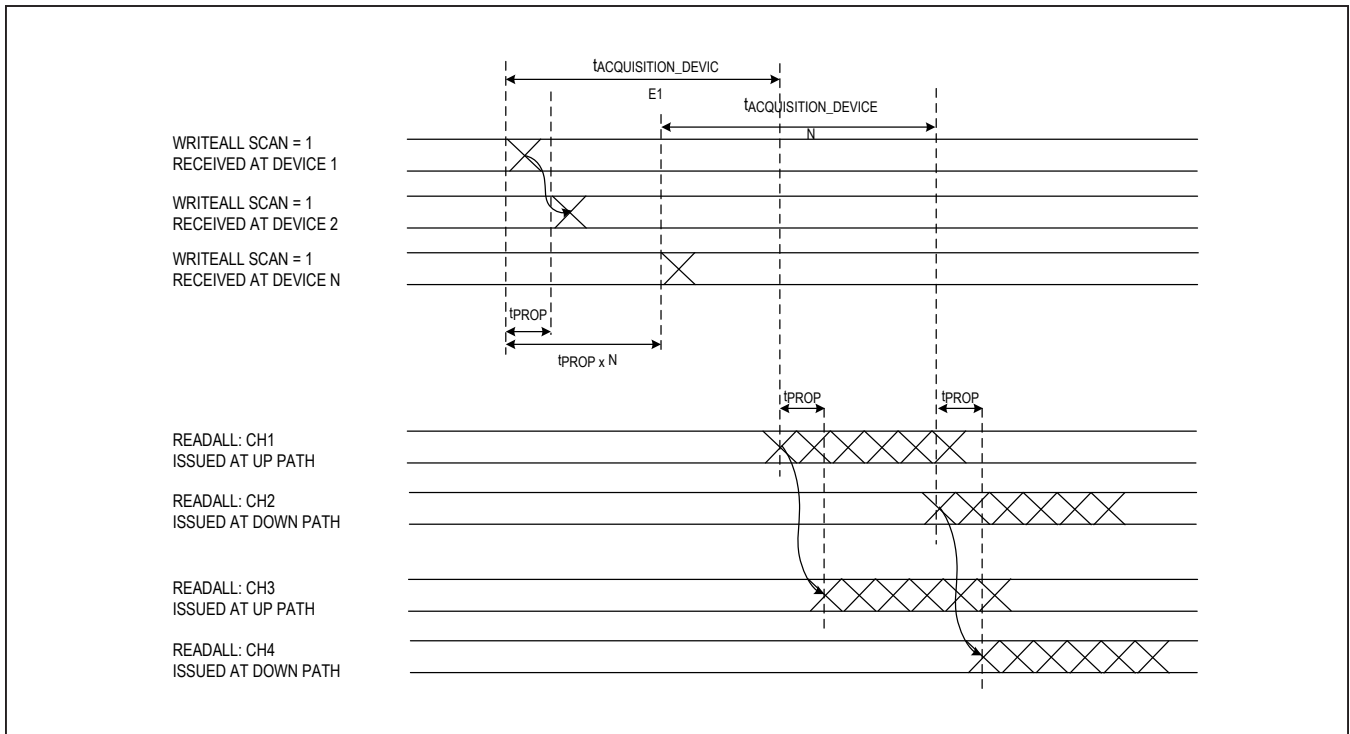

Figure 55. Dual-UART Master/Slave Interaction (Timing Considerations)

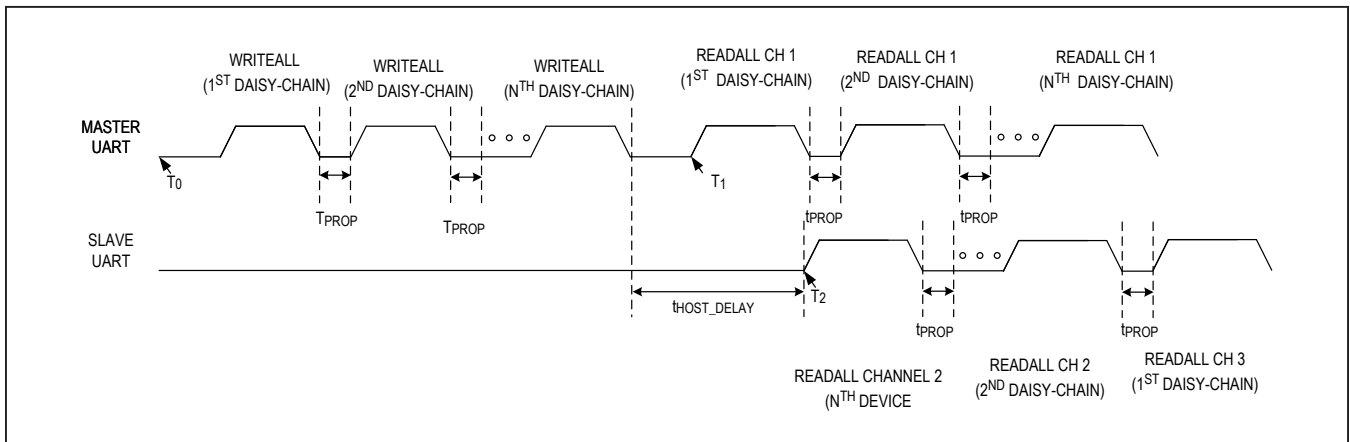

Figure 56. Dual-UART Command Timing

UARTHOST bit, or by invalid commands signified by the ALRTDUALUART bit.

UART Ports

Two UART ports are utilized, a lower port (RXL/TXL) and an upper port (RXU/TXU). Each port consists of a differential line driver and differential line receiver. DC-blocking capacitors or transformers can be used to isolate daisy-chained devices operating at different common-mode voltages. During communication, the character encoding

provides a balanced signal (50% duty cycle) that ensures charge neutrality on the isolation capacitors.

UART Transmitter

When no data is being transmitted by the UART, the differential outputs must be driven to a common level to maintain a neutral charge difference between the AC-coupling capacitors or to avoid saturation of the isolation transformers. In the default idle mode (low-Z), the transmitter drives both outputs to a logic-low level to balance the charge on the capacitors; this also works well with transformer coupling. The high-Z idle mode (TXLIDLEHIZ, TXUIDLEHIZ=0b1) places the TXn pins in a high-Z state during time periods where the UART is inactive, which can be desirable to minimize the effects of charging and discharging the isolation capacitors. The idle mode for the upper and lower ports can be controlled independently through the TXUIDLEHIZ and TXLIDLEHIZ configuration bits.

UART Receiver

The UART receiver has a wide common-mode input range to tolerate harsh EMC conditions. It can operate in differential mode or single-ended mode (see Table 38). By default, the UART receivers are configured for differential mode. In single-ended mode, the RXP input is grounded and the RXN input receives inverse data, as described in the Applications Information section (see Figure 106). In single-ended mode, the receiver input threshold is negative, so a zero differential voltage ($V_{RXP}, V_{RXN} = 0V$) is

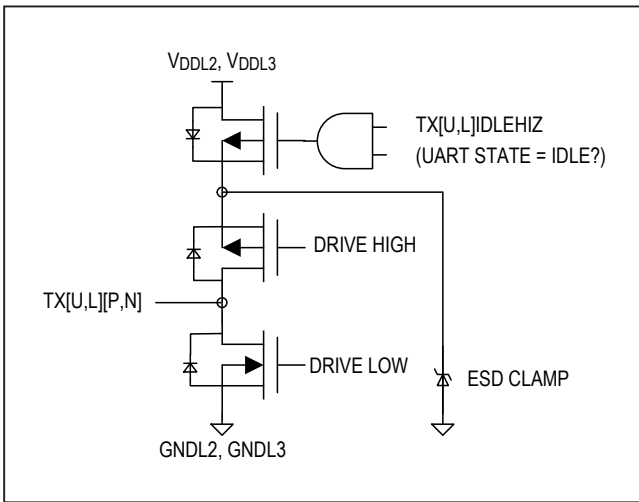

Figure 57. UART Transmitter

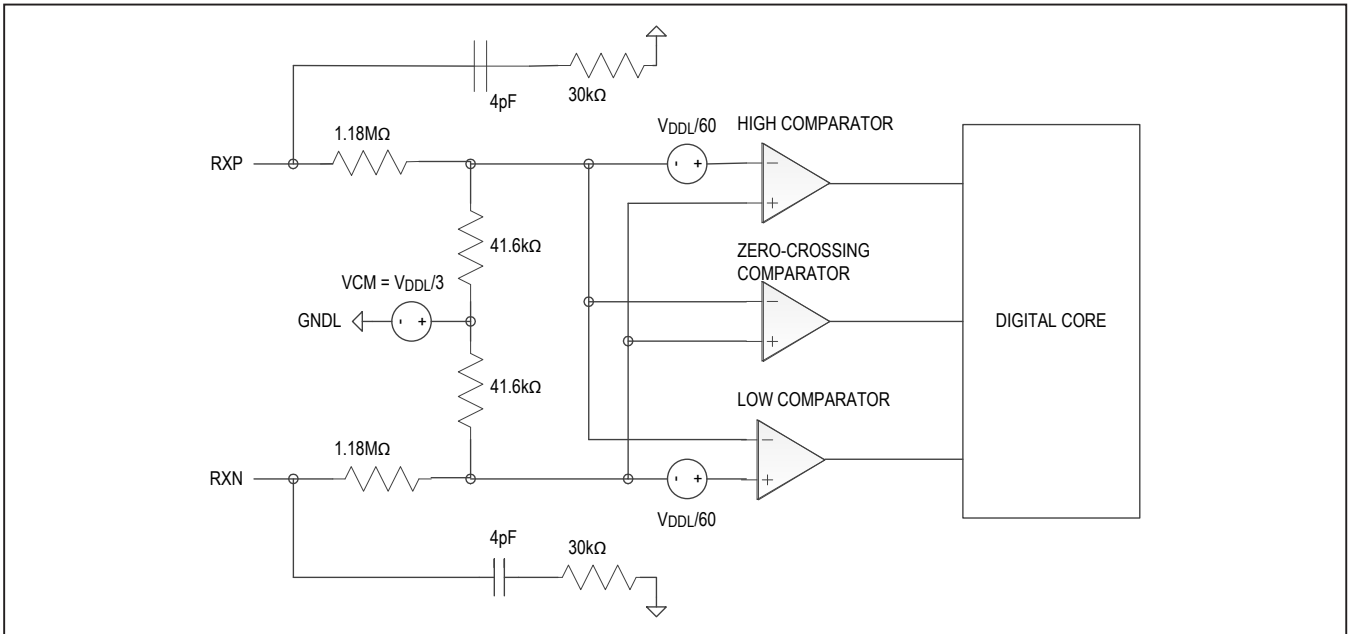

Figure 58. UART Receiver

considered to be a logic one and a negative differential voltage (V_{RXN} high), a logic zero.

SHDNL Charge Pump

The SHDNL input can be driven externally or can be controlled using UART communication only. Using a differential UART configuration, the signaling on the lower-port receiver drives an internal charge pump that charges up the external 1nF capacitor connected to the SHDNL input, as shown

in Figure 59. V_{SHDNL} reaches 1.8V in 200 μ s (typ). The charge pump then self-regulates to the $V_{SHDNLIMIT}$ and can maintain V_{SHDNL} even with the UART idle for long durations. In the event communication is halted, the SHDNL pin voltage falls, with a 10ms time constant (assuming only a 1nF capacitor).

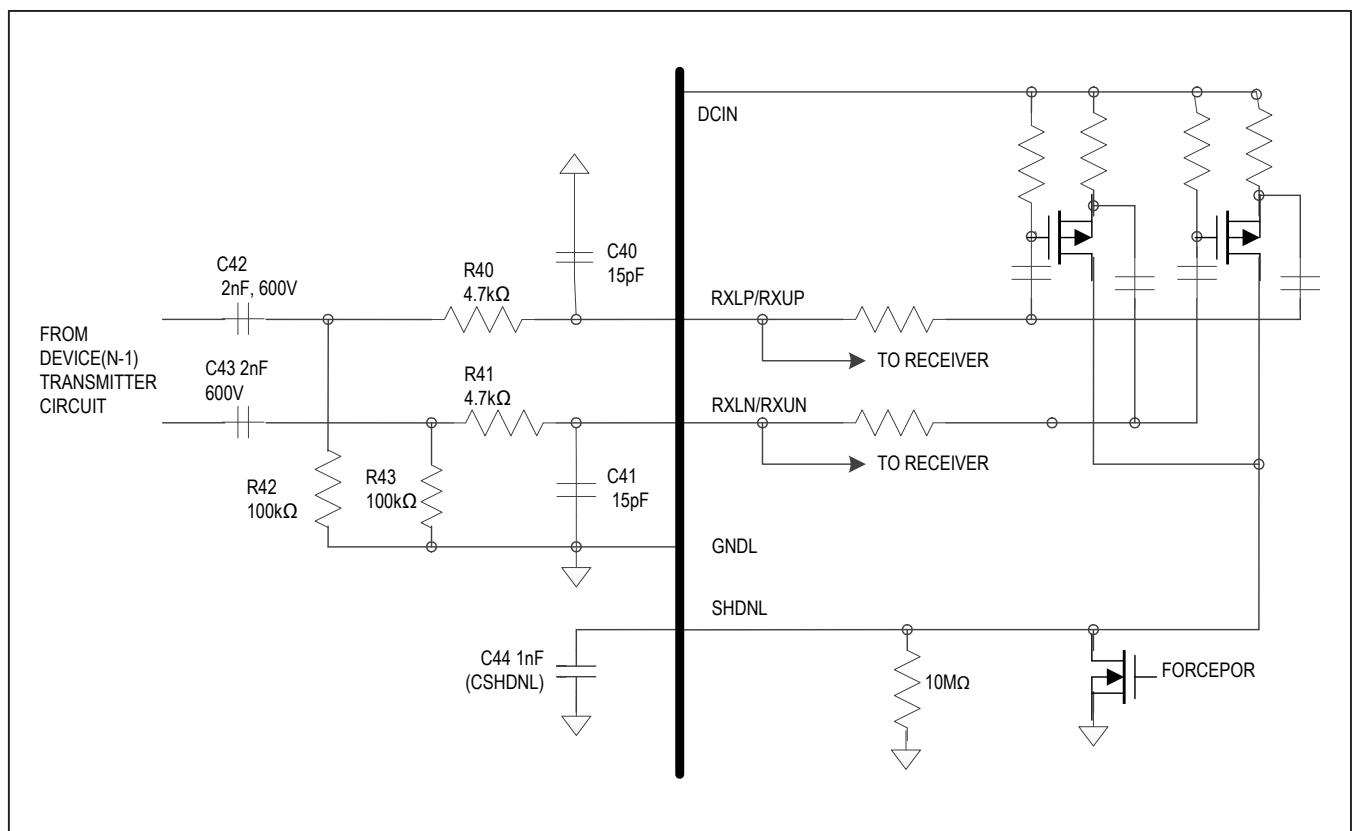

Figure 59. SHDNL Charge Pump

Note: Both upper and lower UART Rx ports are enabled with charge pumps, allowing for communication on either the Up or Down path to initialize the device.

UART Rx Modes

During the first preamble received after a reset, the receiver automatically detects if the received signal is single-ended; if valid, the receiver is appropriately configured in single-ended mode. To be detected, the device must be reset for any change in the receiver hardware configuration. Device reset is signaled to the host through the ALRTRST status bit. In normal operation, this bit is cleared after the first HELLOALL command.

Receiver mode is indicated using the following bits:

- ALRTCOMMSEU1 (for the upper port) and

ALRTCOMMSEL1 (for the lower port) in the FMEA1 register are set after the STATUS1:ALRTRST has been cleared

- ALRTCOMMSEU2 (for the upper port) and ALRTCOMMSEL2 (for the lower port) in the FMEA1 register are set before the STATUS1:ALRTRST has been cleared

See [Table 38](#) for a list of the conditions under which ALRTCOMMSEU1 and ALRTCOMMSEL1 are set. If the RXP input is open circuit, the Rx-mode detection places the UART in single-ended mode so the port can still operate despite reduced noise immunity. The host can diagnose this condition by checking the ALRTCOMMSELn and ALRTCOMMSEUn bits. Any other faults result in communication errors.

Table 38. UART Rx Modes (Post ALRTRST Being Cleared)

STATUS1:ALRTRST	RXP	RXN	ALRTCOMMSEX1	Rx MODE
x	Connected to data	Connected to inverse data	0	Differential mode (normal)
0	Grounded	Connected to inverse data	1	Single-ended mode (normal)
0	Open circuit (fault)	Connected to inverse data	1	Single-ended mode (low noise immunity)
x	Connected to data	Open-circuit (fault)	0	Differential mode (communication errors)
1	Don't care	Don't care	0	—

Table 39. UART Rx Modes (Prior to ALRTRST Being Cleared)

STATUS1:ALRTRST	RXP	RXN	ALRTCOMMSEX2	Rx MODE
x	Connected to data	Connected to inverse data	0	Differential mode (normal)
1	Grounded	Connected to inverse data	1	Single-ended mode (normal)
1	Open circuit (fault)	Connected to inverse data	1	Single-ended mode (low noise immunity)
x	Connected to data	Open circuit (fault)	0	Differential mode (communication errors)
0	Don't care	Don't care	0	—

Note: ALRTCOMMSEU1 and ALRTCOMMSEL1 both read 0b0 if STATUS1:ALRTRST=0b1. ALRTCOMMSEU2 and ALRTCOMMSEL2 both read 0b0 if STATUS1:ALRTRST=0b0.

[Table 39](#) lists conditions under which ALRTCOMMSEU2 and ALRTCOMMSEL2 are set.

Baud-Rate Detection

The UART can operate at a baud rate of 2Mbps, 1Mbps, or 0.5Mbps. The baud rate is controlled by the host and is automatically detected by the device when the first preamble character is received after reset. If the host changes the baud rate, it must issue a reset and resend a minimum of $2 \times n$ preambles at the new baud rate (where n = number of devices). The $2 \times n$ preambles are necessary because the transmitter for the upper port does not transmit data until the lower-port receiver has detected the baud rate; likewise, the transmitter on the lower port does not transmit data until the upper-port receiver has detected the baud rate. A simple way to do this is for the host to start transmitting preambles and stop when a preamble has been received back at the host Rx port.

Sending $2 \times n$ preambles completes baud detection on all n devices in the chain. To receive a preamble back at the host Rx port, $(2 \times n) + 1$ preambles must be sent.

Note: Baud rate for dual-UART configuration is determined during the initialization sequence of either the Up path or Down path. Both paths operate at the same communication rate.

Tx Adaptive Mode for Single-Ended Mode

To overcome the error-tolerance limitation when connecting a MAX17853 to a conventional UART port, an adaptive transmit-timing feature has been added. The feature works by monitoring the location of the incoming Manchester transitions at the RXL port, with respect to the local clock, to calculate a correction factor. This correction factor is then applied to the TXL port so the outgoing Down-path signal has similar timing characteristics to the

incoming Up-path signal. With this adaptive transmit timing, the interface between a conventional UART node and a Maxim proprietary battery-monitoring-system node has a tolerance for baud-rate mismatch much higher than that of the conventional receiver port alone, providing a high level of timing margin for direct-connection applications.

Battery-Management UART Protocol

The Maxim Battery-Management UART Protocol uses the following features to maximize the integrity of its communications:

- All transmitted Manchester-encoded data bytes, where each data bit is transmitted twice with the second bit inverted (G.E. Thomas convention)
- Every transmitted character contains 12 bits that include a start bit, a parity bit, and two stop bits
- Read/write packets contain a CRC-8 packet-error checking (PEC) byte
- Each packet is framed by a preamble character and a stop character
- Read packets contain a data-check byte to verify the integrity of the transmission

The protocol is also designed to minimize power consumption by allowing slave devices to shut down if the UART is idle for a specified period of time. The host must periodically transmit data to prevent shutdown, unless the SHDNL input is driven externally.

Command Packet

A command packet is defined as a sequence of UART characters originating at the host. Each packet starts with a preamble character, followed by data characters, and ending with a stop character, as shown in [Figure 60](#). After

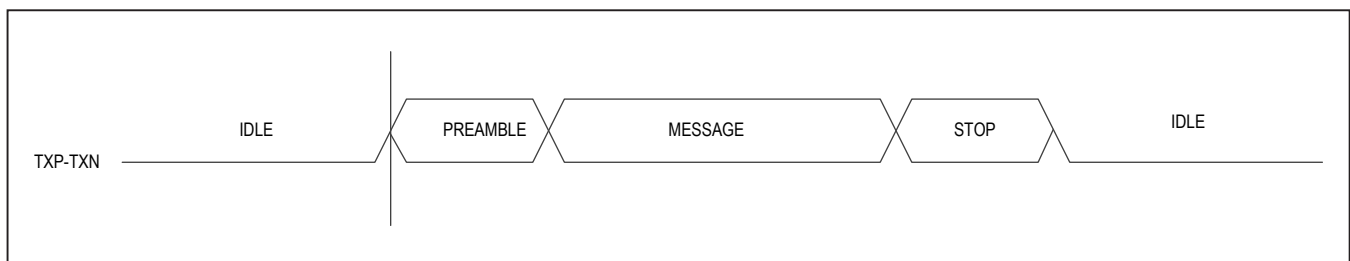

Figure 60. Command Packet

sending a packet, the host either goes into idle mode or sends another packet.

Preamble Character

The preamble is a framing character that signals the beginning of a command packet. It is transmitted as an unencoded 15h, with a logic-one parity bit and a balanced duty cycle. If any bit(s) other than the stop bits deviate from the unique preamble sequence, the character is not interpreted as a valid preamble, but rather as a data character. See [Figure 61](#) for an example.

Data Characters

Each data character contains a single-nibble (4-bit) payload, so two characters must be transmitted for each byte of data. All data is transmitted least-significant bit, least-significant nibble, and least-significant byte first. See [Table 40](#), and [Figure 62](#) for an example. The data itself is Manchester encoded, which means that each data bit is followed by its complement. If the UART detects a Manchester-encoding error in any received data character, it sets the ALRTMANUP or ALRTMANDN bit in the STATUS2 register. All single-UART configurations set

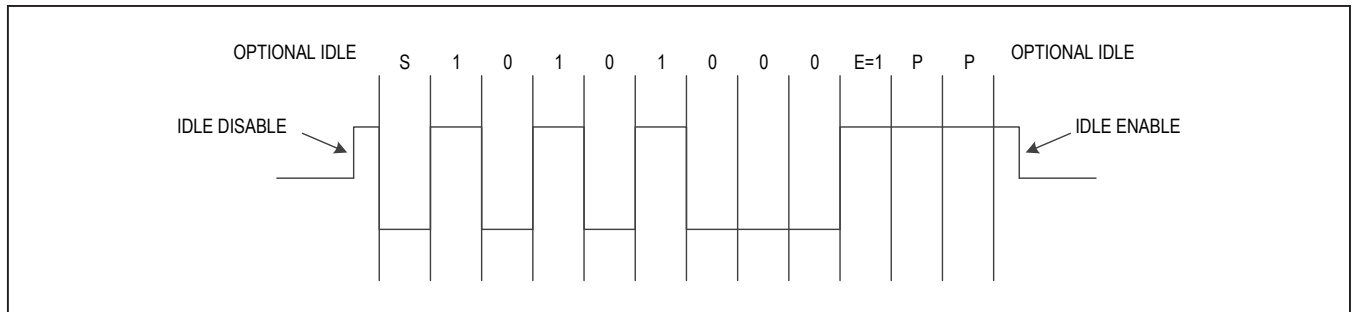

Figure 61. Preamble Character

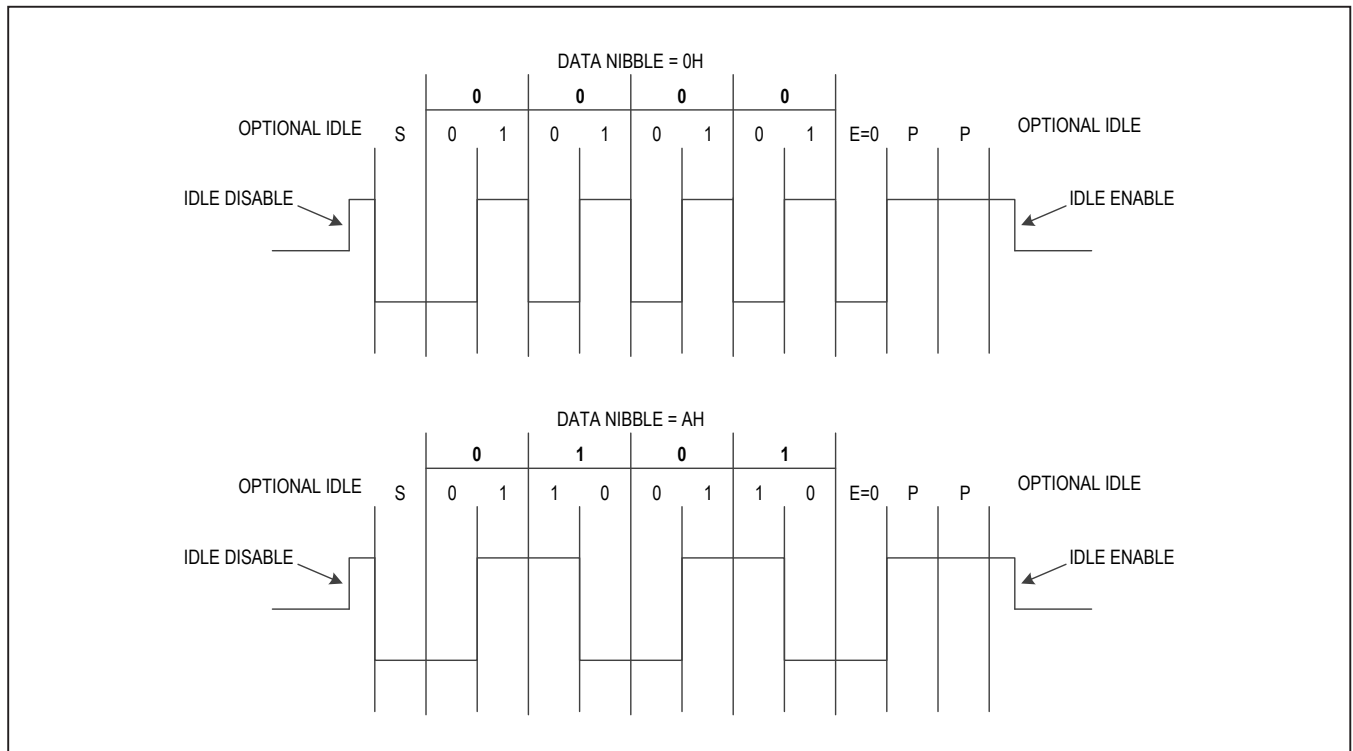

Figure 62. Data Characters

the ALRTMANUP bit. In a dual-UART configuration, a Manchester error in the Up path sets the ALRTMANUP, and a Manchester error in the Down path sets the ALRTMANDN.

The parity is even, meaning the parity bit's value should always result in an even number of logic-one bits in the character. Given the data is Manchester encoded and there are two stop bits, the parity bit for data characters

is always transmitted as a logic zero. If the UART detects a parity error in any received data character, it sets the ALRTPARUP or ALRTPARDN bit in the STATUS2 register. All single-UART configurations set the ALRTPARUP bit. In a dual-UART configuration, a parity error in the Up path sets ALRTPARUP and a parity error in the Down path sets ALRTPARDN.

Stop Character

Table 40. Data Character Description

BIT	NAME	SYMBOL	DESCRIPTION
1	Start	S	First bit in character, always logic zero
2	Data0		Least significant bit of data nibble (true)
3	Data0/		Least significant bit of data nibble (inverted)
4	Data1		Data bit 1 (true)
5	Data1/		Data bit 1 (inverted)
6	Data2		Data bit 2 (true)
7	Data2/		Data bit 2 (inverted)
8	Data3		Most significant bit of data nibble (true)
9	Data3/		Most significant bit of data nibble (inverted)
10	Parity	E	Always logic zero (even parity)
11	Stop	P	Always logic one
12	Stop	P	Last bit in character, always logic one

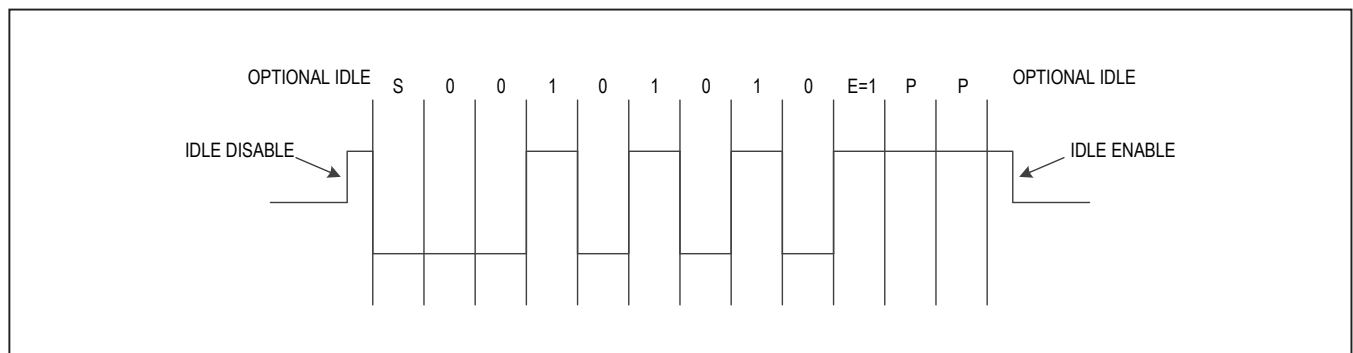

Figure 63. Stop Character

The stop character is a framing character that signals the end of a command packet (see [Figure 63](#)). It is transmitted as an unencoded 54h, with a logic-one parity bit and a balanced duty cycle.

UART Idle Mode

In the low-Z (default) idle mode, the transmitter outputs are both driven to 0V, as shown in [Figure 64](#). In the high-Z idle mode, the transmitter outputs are not driven by the UART. The MAX17841B interface automatically places its transmitter in idle mode immediately after each command

packet and remains in idle mode until either the next command packet is sent or it goes into keep-alive mode, sending periodic stop characters to prevent the daisy-chained device(s) from going into shutdown.

UART Communication Mode

When transitioning from idle mode to communication mode, the TXP pin must be pulled high (logic one) prior to signaling the start bit (logic zero), as shown in [Figure 64](#). The duration of the logic one is minimized to maintain a balanced duty cycle while still meeting the timing specification. When transitioning from the stop bit back to idle mode, the delay, if any, is also minimized.

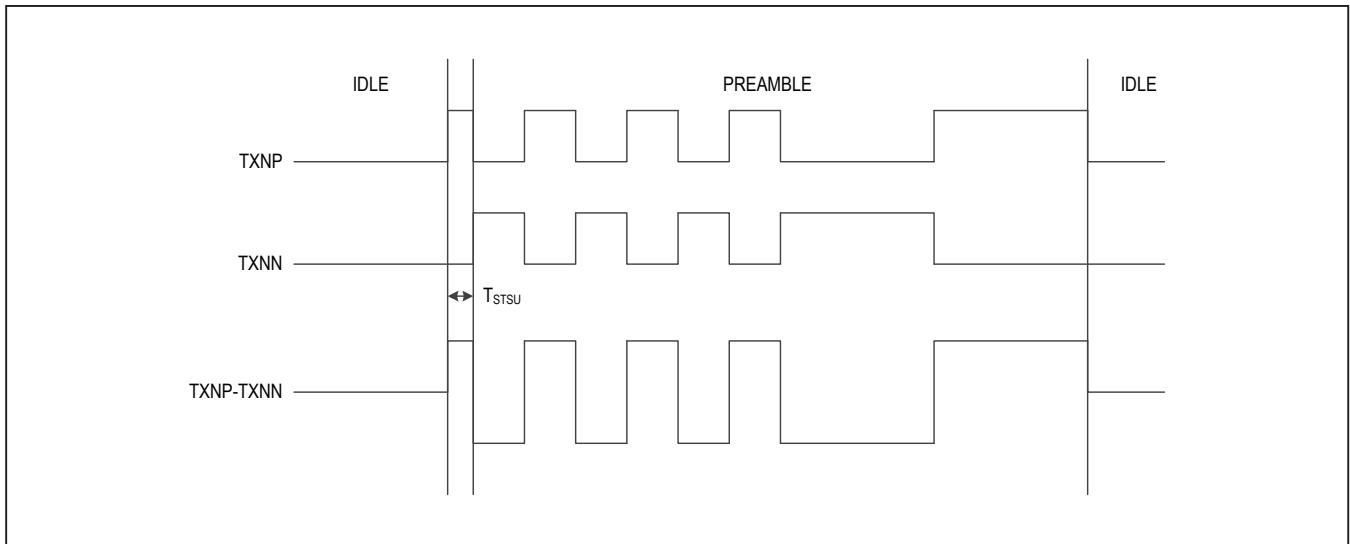

Figure 64. Communication Mode

Table 41. Data Types

DATA TYPE	DESCRIPTION
Command byte	A byte defining the command packet type, generally either a READ or a WRITE
Register address	A byte defining the register address to be read from or written to
Register data	Register data bytes being read from or written to
Data-check byte	An error and alert-status byte sent and returned with all reads
Packet-error checking byte	A packet-rror checking (PEC) byte sent and returned with every packet except HELLOALL
Alive-counter	A byte functioning as a device counter on all reads and writes, if ALIVECNTEN=1
Fill byte	Bytes transmitted in READALL and READBLOCK command packets (for clocking purposes only)

Data Types

The Battery-Management UART Protocol employs several different data types, as described in [Table 41](#).

Command Bytes

The Battery-Management UART Protocol supports eight command types, summarized in [Table 42](#).

Command-Byte Encoding

Command-byte encoding is described in [Table 43](#). For READDEVICE and WRITEDEVICE commands, the

device address is encoded in the command byte. The device ignores those commands containing a device address other than its own.

Register Addresses

All register addresses are single-byte quantities and are defined in the [Register Map](#). In general, if the register or device address in a received command is not a valid address for the device, the device ignores the read or write and simply passes through the packet to the next device.

Table 42. Command Packet Types

COMMAND	DESCRIPTION	DATA-CHECK	PEC	ALIVE-COUNTER	PACKET SIZE (CHARACTERS)
HELLOALL	Writes a unique device address to each device in the daisy-chain. Required for system initialization.	No	No	No	8
WRITEALL	Writes a specific register in all devices.	No	Yes	Yes	14
WRITEDEVICE	Writes a specific register in a single device.	No	Yes	Yes	14
READALL	Reads a specific register from all devices.	Yes	Yes	Yes	12 + (4z)
READDEVICE	Reads a specific register from a single device.	Yes	Yes	Yes	16
READBLOCK	Reads a set of registers from a single device.	Yes	Yes	Yes	14 + (4* BS)
UPHOST	Makes the Up path the master in a dual-UART configuration. Sets bitfield UARHOST=0b1.	No	Yes	No	10
DOWNHOST	Makes the Down path the master in a dual-UART configuration. Sets bitfield UARHOST=0b0.	No	Yes	No	10

Note: z = Total number of devices, ALIVECNTEN=1, packet size includes framing characters.

**Block size[4:0] = 1–32, which is the number of registers read.*

Table 43. Battery-Management Protocol (Command-Byte Encoding)

COMMAND	BYTE*	7	6	5	4	3	2	1	0
HELLOALL	57h	0	1	0	1	0	1	1	1
ALERTPACKET	21h	0	0	1	0	0	0	0	1
WRITEDEVICE	04h	DA4	DA3	DA2	DA1	DA0	1	0	0
WRITEALL	02h	0	0	0	0	0	0	1	0
READDEVICE	05h	DA4	DAe	DA2	DA1	DA0	1	0	1
READALL	03h	0	0	0	0	0	0	1	1
READBLOCK	06h	BS4	BSe	BS2	BS1	BS0	1	1	0
DOWNHOST	09h	0	0	0	0	1	0	0	1
UPHOST	08h	0	0	0	0	1	0	0	0

**Assumes DA[4:0]=0x00 where DA[4:0] is the device address in the ADDRESS register.*

BS[4:0] = Block size (1–32).

Register Data

All registers are 16-bit words (2 data bytes) and are defined in the [Register Map](#).

Data-Check Byte

The host uses the returned data-check byte to promptly determine if any communication errors occurred during the packet transmission and to check if alert flags are set in any devices, as shown in [Table 44](#). Individual alert conditions can be masked out of the data-check byte using settings in ALRTIRQEN; however, the underlying alert information will not always be available for readback in the STATUS1 register. The data-check byte is returned by the READALL, READDEVICE, and READBLOCK commands. For READDEVICE, the data-check byte is updated only by the addressed device.

The data-check byte that is sent by the host is a seed value normally set to 00h although non-zero values and can be used as a diagnostic. Each device logically ORs the received data-check byte with its own status and transmits it to the next device. A PEC error detected by any device sets the appropriate ALRTPECUP or ALRTPECDN in the STATUS2 register, and thus, the ALRTPEC rollup bit in the STATUS1 register. Also, the device sets the PEC error bit in the data-check byte within the associated path's command packet, as described below.

Note: STATUS1,15:ALRTSCAN is a procedural notification bit and is not included intentionally in the data-check byte. It is available for inclusion in the Alert interface to support interrupt-driven applications. STATUS1,14:ALTRST

indicates a POR condition, and thus cannot be masked. STATUS1,5:ALRTPEC is not included intentionally in the data-check byte.

PEC Byte

The PEC byte is a CRC-8 packet error check (PEC) sent by the host with all READ and WRITE commands. If any device receives an invalid PEC byte, it sets the ALRTPECUP, or ALRTPECDN bit in the STATUS2 register, and also the ALRTPEC bit in the STATUS1 register. All single-UART configurations set the ALRTPECUP bit. In a dual-UART configuration, a PEC error in the Up path sets ALRTPECUP, and a PEC error in the Down path sets the ALRTPECDN. During any write transaction, a device does not execute the WRITE command internally unless the received PEC matches the expected calculated value. For READ commands, the device must return its own calculated PEC byte based on the returned data. The host should verify that the received PEC byte matches the calculated value and if an error is indicated, the data should be discarded. See the [Applications Information](#) section for details on the PEC calculation.

Alive-Counter Byte

The alive-counter byte is the last data byte of the command packets (except HELLOALL, UPHOST, and DOWNHOST) if the ALIVECNTEN bit is set in the DEVCFG1 register. The host typically transmits the alive-counter seed value as 00h but any value is permitted. For WRITEALL or READALL commands, each device retransmits the alive-counter incremented by one. For WRITEDevice or READDevice commands, only the

Table 44. Data-Check Byte

BIT	NAME	DESCRIPTION
7	PEC ERROR	PEC error detected during the current transaction on the Up/Down path issuing this bit.
6	ALRTFMEA	(ALRTFMEA1 & FMEA1ALRTEN) or (ALRTFMEA2 & FMEA2ALRTEN)
5	ALRTSTATUS	ALTRST or (ALRTMSMTCH & MSMTCHALRTEN) or (ALRTBLKOVST & BLKOVVALRTEN) or (ALRTBLKUVST & BLKUVVALRTEN) or (ALRTINTRFC & INTRFCALRTEN) or (ALRTCAL & CALALRTEN) or (ALRTCBAL & CBALALRTEN)
4	AUXOV (UT)	(ALRTAUXOVST & AUXOVSTALRTEN)
3	AUXUV (OT)	(ALRTAUXUVST & AUXUVSTALRTEN)
2	CELLOV	(ALRTCELLOVST & CELLOVSTALRTEN)
1	CELLUV	(ALRTCELLUVST & CELLUVSTALRTEN)
0	RESERVED	0

addressed device increments it. The alive-counter is not used in the HELLOALL, UPHOST, and DOWNHOST commands. If the alive-counter reaches FFh, the next device increments it to 00h.

Since the alive-counter comes after the PEC byte, an incorrect PEC value will not affect the incrementing of the alive-counter byte. Also, the PEC calculation does not include the alive-counter byte. The host should verify that the alive-counter equals the original seed value + the number of devices, considering that if the alive-counter reaches FFh, the next device increments it to 00h.

Fill Bytes

In the READALL command, the host sends two fill bytes for each device in the daisy-chain. The fill bytes are the locations within the packet that are used by the device to place the read data. The fill-byte values transmitted by the MAX17841B interface alternate between C2h and D3h. As the command packet propagates through the device, the device overwrites the appropriate fill bytes with the register data. The device uses the ADDRESS register to determine which specific fill bytes in the packet to overwrite. For a READBLOCK command, the number of fill bytes sent is equal to the read-data block size.

For a READDEVICE command, only two fill bytes are required since only one device responds (returning two data bytes). Also, fill bytes are not required for WRITE commands because the data received is exactly the same as the data retransmitted.

Battery-Management UART Protocol Commands

HELLOALL Command

The HELLOALL command initializes the daisy-chain device addresses after a POR. The device addresses are stored in the DA[4:0] bits of the ADDRESS register with the highest address being 0x1F. Thus, a maximum of 32 devices can be addressed.

The device address bits (DA[4:0]) in the HELLOALL command packet are seeded by the host microcontroller. The command proceeds to the first device of the daisy-chain and is stored in that device's DA bits of the ADDRESS register. The first device then increments or decrements the HELLOALL command-packet bitfield DA[4:0] according to the UARTHOST configuration settling (see the [HELLOALL Operation in Dual-UART Configuration](#) section). Thus, the initial seeded value corresponds to the first device's address in the daisy-chain. The command continues to

propagate to the next device until it returns to the host, at which point the host is able to determine the total number of devices in the daisy-chain for subsequent READALL, READDEVICE, READBLOCK commands.

HELLOALL Operation in Dual-UART Configuration

By default, dual-UART operation is configured with the primary communication path being the Up path (refer to the UARTCFG and UARTHOST bits in the DEVCFG1 register for details about defaults and possible configurations), where the Up path is defined as transmission from the TXU port to the RXL port. The DA[4:0] bits in the HELLOALL command packet are incremented as they progress up the daisy-chain. Thus, when the HELLOALL is received by the host microcontroller, the DA[4:0] value returned is one greater than the address assigned to the top device.

It is recommended that the host seeds the initial address of the Up path at a value of 0x00. This configuration applies to the first address of the daisy-chain at the same value of the default condition of the bottom address (BA bits in the ADDRESS register). Thus, it is not necessary to write the bottom address BA[4:0] to all the devices. The host microcontroller should never set the bottom address at a value that would result in the device address exceeding 0x1F.

Note: The device address is only stored and incremented in the Up path, and then passes through the Down path, leaving the device address unaffected. As such, if the hardware is configured as a single daisy-chain and the UART is looped back using the Down path, the UARTHOST configuration prevents the Down path from changing the device address already determined.

The HELLOALL command packet can also be applied through the Down path, where the Down path is defined as transmission from the TXL port to the RXU port. For proper operation, the host microcontroller must first send the DOWNHOST command through the Down path prior to sending the HELLOALL.

The device address in the HELLOALL command packet is decremented as it progresses down the daisy-chain. Thus, the address of the top daisy-chain (first device in the Down path) will be the value that is seeded in the DA[4:0] bits of the HELLOALL command packet. This top daisy-chain device proceeds to decrement the DA[4:0] and propagates the value down the daisy-chain. When the HELLOALL is received by the host microcontroller, the DA[4:0] value returned is one less than the address

assigned to the bottom device. The host microcontroller should never set the top address at a value which would result in a DA[4:0] decremented below 0x0.

After the HELLOALL is processed, the TA bits (Top Address bits) in the ADDRESS register must be set to the initial DA[4:0] seeded value.

It is recommended that the host seeds the initial address of the Down path at a value equal to the number of devices in the daisy-chain, such that the bottom address is 0x00. This configuration ensures that whether the HELLOALL is sent through the Up path or Down path, the device address remains the same, which is ideal for consistency with the addressing of the READDEVICE, and READALL commands.

Note: The device address is only stored and decremented in the Down path and passes through the Up path leaving the device address unaffected (I.e., HELLOALL sent in the Up path with UARTHST=1'b0).

HELLOALL Operation In a Single-UART Configuraiton

In a single-UART configuration the HELLOALL is processed the same as in the dual-UART Up path.

Special considerations exist if the host desires to use internal loopback instead of external loopback. The first HELLOALL command is not returned to the host because the internal loopback (UARTCFG) for the top device has not yet been written. If the number of devices is known to the host, the host can use a WRITEDEVICE to set the internal loopback bit on the last device and then verify with a READALL. If the number of devices is unknown, the internal loopback bit must be set on the first device, verified and then cleared. It can then be set on the second device and verified, and so on incrementally until there is no response (end of stack). With the number of devices known, the loopback bit can be reset on the top device and all ADDRESS registers verified.

HELLOALL Address Lock

When a device receives a valid HELLOALL command, it clears the ADDRUNLOCK bit of the ADDRESS register. When this bit is 0, HELLOALL commands are ignored to

Table 45. HELLOALL Command Packet

HELLOALL
Preamble
57h
00h
{0b000,DA[4:0]}
Stop

Table 46. HELLOALL Up-Path Sequencing

HELLOALL UP-PATH SEQUENCING (z = TOTAL NUMBER OF DEVICES)			
HOST TX	DEVICE (n) RXL	DEVICE (n) TXU	HOST Rx
Preamble	Preamble	Preamble	Preamble
57h	57h	57h	57h
00h	00h	00h	00h
{0b000,DA[4:0]}	{0b000,DA[4:0]+n-1}	{0b000,DA[4:0]+n}	{0b000,DA[4:0]+z}
Stop	Stop	Stop	Stop

Table 47. HELLOALL Down-Path Sequencing

HELLOALL SEQUENCING (z = TOTAL NUMBER OF DEVICES)			
HOST Tx	DEVICE (n) RXU	DEVICE (n) TXL	HOST Rx
Preamble	Preamble	Preamble	Preamble
57h	57h	57h	57h
00h	00h	00h	00h
{0b000,ADDR[4:0]}	{0b000,ADDR[4:0]-(n-1)}	{0b000,ADDR[4:0]-n}	{0b000,ADDR[4:0]-z}
Stop	Stop	Stop	Stop

prevent inadvertently changing any device address. To reconfigure the device address, the ADDRUNLOCK bit must first be set to 1, or a POR event must occur. After configuring the device addresses, they should be verified using the READALL command.

WRITEALL Command

The WRITEALL command writes a 16-bit value to a specified register in all daisy-chain devices. Since most configuration information is common to all the devices, this command allows faster setup than individually writing to each device. If the register address is not valid for the device, the command is ignored. The command sequence is shown in [Table 48](#).

The register value is written immediately after the valid PEC byte is received or, if NOPEC is set, after the last byte received. If the received PEC byte does not match the internal calculation, the command is not executed, but is still forwarded to the next device. The PEC is calculated from the first 4 bytes of the command starting after the preamble. If any device receives an invalid

PEC byte, it sets the ALRTPECUP or ALRTPECDN bit in the STATUS2 register, and also the ALRTPEC bit in the STATUS1 register. All single-UART configurations set the ALRTPECUP bit. In a dual-UART configuration, a PEC error in the Up path sets ALRTPECUP, and a PEC error in the Down path sets the ALRTPECDN.

WRITEDEVICE Command

The WRITEDEVICE command writes a 16-bit value to the specified register in the addressed device only. If the register address is not valid for the device, the command is ignored. The command sequence is shown in [Table 49](#).

The register value is written immediately after the valid PEC byte is received or, if NOPEC is set, after the last byte received. If the received PEC byte does not match the internal calculation, the command is not executed, but is still forwarded to the next device. The PEC is calculated from the first 4 bytes of the command starting after the preamble. If the addressed device receives an invalid PEC byte, it sets the ALRTPECUP, or ALRTPECDN bit in

Table 48. WRITEALL Sequencing (Unchanged by Daisy-Chain)

HOST Tx	DEVICE(n) RXL (UP PATH) OR RXU (DOWN PATH)	DEVICE(n) TXU (UP PATH) OR TXL (DOWN PATH)	HOST Rx
Preamble	Preamble	Preamble	Preamble
02h	02h	02h	02h
[REG ADDR]	[REG ADDR]	[REG ADDR]	[REG ADDR]
[DATA LSB]	[DATA LSB]	[DATA LSB]	[DATA LSB]
[DATA MSB]	[DATA MSB]	[DATA MSB]	[DATA MSB]
[PEC]	[PEC]	[PEC]	[PEC]
[ALIVE]*	[ALIVE]*	[ALIVE]*	[ALIVE]*
Stop	Stop	Stop	Stop

*If alive-counter mode is enabled.

Table 49. WRITEDEVICE Sequencing (Unchanged by Daisy-Chain)

HOST Tx	DEVICE RXL (UP PATH) OR RXU (DOWN PATH)	DEVICE TXU (UP PATH) OR TXL (DOWN PATH)	HOST Rx
Preamble	Preamble	Preamble	Preamble
{(DA[4:0]),0b100}	{(DA[4:0]),0b100}	{(DA[4:0]),0b100}	{(DA[4:0]),0b100}
[REG ADDR]	[REG ADDR]	[REG ADDR]	[REG ADDR]
[DATA LSB]	[DATA LSB]	[DATA LSB]	[DATA LSB]
[DATA MSB]	[DATA MSB]	[DATA MSB]	[DATA MSB]
[PEC]	[PEC]	[PEC]	[PEC]
[ALIVE]*	[ALIVE]*	[ALIVE]*	[ALIVE]*
Stop	Stop	Stop	Stop

*If alive-counter mode is enabled.

the STATUS2 register, and also the ALRTPEC bit in the STATUS1 register. All single-UART configurations set the ALRTPECUP bit. In a dual-UART configuration, a PEC error in the Up path sets ALRTPECUP, and a PEC error in the Down path sets the ALRTPECDN. A PEC error can only occur in the addressed device.

READALL Command

The READALL command returns register data from the specified register for all daisy-chained devices. The data for the first device (connected to the host) is returned last. The command sequence is shown in [Table 50](#) and [Table 51](#). If the received PEC byte does not match the calculated value, the UART sets the ALRTPECUP, or ALRTPECDN

bit in the STATUS2 register, and also the ALRTPEC bit in the STATUS1 register. All single-UART configurations set the ALRTPECUP bit. In a dual-UART configuration, a PEC error in the Up path sets ALRTPECUP, and a PEC error in the Down path sets ALRTPECDN; however, the command proceeds to the next device in the daisy-chain. A Manchester error immediately switches the data propagation from read mode to write (pass-through) mode, ensuring that the Manchester error is propagated through the daisy-chain and back to the host.

The fill-byte values transmitted by the MAX17841B interface alternate between C2h and D3h, as shown. As the packet propagates through the device, the device retrans-

Table 50. READALL Command Sequencing In Single-UART or Dual-UART Up Path (z = Number of Devices)

HOST Tx	DEVICE(n) RXL	DEVICE(n) TXU	HOST Rx
Preamble	Preamble	Preamble	Preamble
03h	03h	03h	03h
[REG ADDR]	[REG ADDR]	[DATA ADDR]	[REG ADDR]
[DC] = 0x00	[DATA LSB(n-1)]	[DATA LSB(n)]	[DATA LSB(z)] = [DATA LSB(TA)]
[PEC]	[DATA MSB(n-1)]	[DATA MSB(n)]	[DATA MSB(z)] = [DATA MSB(TA)]
[ALIVE]*	[DATA LSB(z-1)] = [DATA LSB(TA-1)]
[FD(1) C2h]	[DATA MSB(z-1)] = [DATA MSB(TA-1)]
[FD(1) D3h]	[DATA LSB(1)] = [DATA LSB(BA)]	[DATA LSB(1)] = [DATA LSB(BA)]	...
[FD(2) C2h]	[DATA MSB(1)] = [DATA MSB(BA)]	[DATA MSB(1)] = [DATA MSB(BA)]	...
[FD(2) D3h]	[DC]	[DC]	...
...	[PEC]	[PEC]	...
...	[ALIVE]*	[ALIVE]*	...
...	[FD(1) C2h]	[FD(1) C2h]	...
...	[FD(1) D3h]	[FD(1) D3h]	[DATA LSB(1)] = [DATA LSB(BA)]
...	[DATA MSB(1)] = [DATA MSB(BA)]
...	[DC]
[FD(z) C2h]	[FD(z-n) C2h]	[FD(z-n-1) C2h]	[PEC]
[FD(z) D3h]	[FD(z-n) D3h]	[FD(z-n-1) D3h]	[ALIVE]*
Stop	Stop	Stop	Stop
12+(4 x z) characters	12+(4 x z) characters	12+(4 x z) characters	12+(4 x z) characters

*If alive-counter mode is enabled.

**Table 51. READALL Command Sequencing In Dual-UART Down Path
(z = Number of Devices)**

HOST Tx	DEVICE(n) RXU	DEVICE(n) TXL	HOST Rx
Preamble	Preamble	Preamble	Preamble
03h	03h	03h	03h
[REG ADDR]	[REG ADDR]	[DATA ADDR]	[REG ADDR]
[DC] = 0x00	[DATA LSB(n-1)]	[DATA LSB(n)]	[DATA LSB(z)] = [DATA LSB(BA)]
[PEC]	[DATA MSB(n-1)]	[DATA MSB(n)]	[DATA MSB(z)] = [DATA MSB(BA)]
[ALIVE]*	[DATA LSB(z-1)] = [DATA LSB(BA + 1)]
[FD(1) C2h]	[DATA MSB(z-1)] = [DATA MSB(BA + 1)]
[FD(1) D3h]	[DATA LSB(1)] = [DATA LSB(TA)]	[DATA LSB(1)] = [DATA LSB(TA)]	...
[FD(2) C2h]	[DATA MSB(1)] = [DATA MSB(TA)]	[DATA MSB(1)] = [DATA MSB(TA)]	...
[FD(2) D3h]	[DC]	[DC]	...
...	[PEC]	[PEC]	...
...	[ALIVE]*	[ALIVE]*	...
...	[FD(1) C2h]	[FD(1) C2h]	...
...	[FD(1) D3h]	[FD(1) D3h]	[DATA LSB(1)] = [DATA LSB(TA)]
...	[DATA MSB(1)] = [DATA MSB(TA)]
...	[DC]
[FD(z) C2h]	[FD(z-n) C2h]	[FD(z-n-1) C2h]	[PEC]
[FD(z) D3h]	[FD(z-n) D3h]	[FD(z-n-1) D3h]	[ALIVE]*
Stop	Stop	Stop	Stop
12+(4 x z) characters	12+(4 x z) characters	12+(4 x z) characters	12+(4 x z) characters

*If alive-counter mode is enabled.

mits it in the order shown in the sequencing table (device TXU column). The device knows which bytes to overwrite since its ADDRESS register contains the top, and bottom device addresses, and its own device address; therefore, it knows where in the data stream it belongs.

READDEVICE Command

The READDEVICE command returns a 16-bit word read from the specified register in the addressed device only.

If the register address is not valid for the device, the command is ignored. The command sequence is shown in [Table 52](#) and [Table 53](#).

The command packet is forwarded up the daisy-chain until it reaches the addressed device. The addressed device overwrites the received fill bytes with the two bytes of register data and forwards the packet to the next device. The alive-counter byte (if enabled) is only

Table 52. READDEVICE Sequencing In Single-UART or Dual-UART Up Path

HOST Tx	DEVICE RXL	DEVICE TXU	HOST Rx
Preamble	Preamble	Preamble	Preamble
{DA[4:0], 0b101}	{DA[4:0], 0b101}	{DA[4:0], 0b101}	{DA[4:0], 0b101}
[REG ADDR]	[REG ADDR]	[REG ADDR]	[REG ADDR]
[DC]	[DC]	[DATA LSB]	[DATA LSB]
[PEC]	[PEC]	[DATA MSB]	[DATA MSB]
[ALIVE]*	[ALIVE]*	[DC]	[DC]
[FD(1) C2h]	[FD(1) C2h]	[PEC]	[PEC]
[FD(1) D3h]	[FD(1) D3h]	[ALIVE]*	[ALIVE]*
Stop	Stop	Stop	Stop
16 characters	16 characters	16 characters	16 characters

**If alive-counter mode is enabled*

Table 53. READDEVICE Sequencing In Dual-UART Down Path

HOST Tx	DEVICE RXU	DEVICE TXL	HOST Rx
Preamble	Preamble	Preamble	Preamble
{DA[4:0], 0b101}	{DA[4:0], 0b101}	{DA[4:0], 0b101}	{DA[4:0], 0b101}
[REG ADDR]	[REG ADDR]	[REG ADDR]	[REG ADDR]
[DC]	[DC]	[DATA LSB]	[DATA LSB]
[PEC]	[PEC]	[DATA MSB]	[DATA MSB]
[ALIVE]*	[ALIVE]*	[DC]	[DC]
[FD(1) C2h]	[FD(1) C2h]	[PEC]	[PEC]
[FD(1) D3h]	[FD(1) D3h]	[ALIVE]*	[ALIVE]*
Stop	Stop	Stop	Stop
16 characters	16 characters	16 characters	16 characters

**If alive-counter mode is enabled.*

incremented by the addressed device. A Manchester error immediately switches the data propagation from read mode to write (pass-through) mode, ensuring that the Manchester error is propagated through the daisy-chain and back to the host.

READBLOCK Command

The READBLOCK command returns a 18-byte read from the specified register for a Block size of 1 in the addressed device only. If the register address is not valid

for the device, it returns 0 for any invalid addresses. If the Device Address is not valid, the command be ignored. The command sequences for a block size of 1 and for a block size of 2 are shown in [Table 54](#) and [Table 55](#) for a block size of 1 and [Table 56](#) and [Table 57](#) for a block size of 2. The command packet is forwarded up the daisy-chain until it reaches the addressed device. The addressed device overwrites the received fill bytes with the 2 bytes of register data (from a single device) and forwards the packet to the next device. The alive-counter

Table 54. READBLOCK Sequencing In Single-UART or Dual-UART Up Path (Block Size = 1)

HOST Tx	DEVICE RXL	DEVICE TXU	HOST Rx
Preamble	Preamble	Preamble	Preamble
{BS[4:0], 3b110}	{BS[4:0], 3b110}	{BS[4:0], 3b110}	{BS[4:0], 3b110}
[DEVICE ADDR]	[DEVICE ADDR]	[DEVICE ADDR]	[DEVICE ADDR]
[REG ADDR]	[REG ADDR]	[REG ADDR]	[REG ADDR]
[DC]	[DC]	[DATA LSB]	[DATA LSB]
[PEC]	[PEC]	[DATA MSB]	[DATA MSB]
[ALIVE]*	[ALIVE]*	[DC]	[DC]
[FD(1) C2h]	[FD(1) C2h]	[PEC]	[PEC]
[FD(1) D3h]	[FD(1) D3h]	[ALIVE]*	[ALIVE]*
Stop	Stop	Stop	Stop
18 characters	18 characters	18 characters	18 characters

**If alive-counter mode is enabled.*

Table 55. READBLOCK Sequencing In Single-UART or Dual-UART Up Path (Block Size = 1)

HOST TX	DEVICE RXL	DEVICE TXU	HOST RX
Preamble	Preamble	Preamble	Preamble
{BS[4:0], 3b110}	{BS[4:0], 3b110}	{BS[4:0], 3b110}	{BS[4:0], 3b110}
[DEVICE ADDR]	[DEVICE ADDR]	[DEVICE ADDR]	[DEVICE ADDR]
[REG ADDR]	[REG ADDR]	[REG ADDR]	[REG ADDR]
[DC]	[DC]	[DATA0 LSB]	[DATA0 LSB]
[PEC]	[PEC]	[DATA0 MSB]	[DATA0 MSB]
[ALIVE]*	[ALIVE]*	[DATA1 LSB]	[DATA1 LSB]
[FD(1) C2h]	[FD(1) C2h]	[DATA1 MSB]	[DATA1 MSB]
[FD(1) D3h]	[FD(1) D3h]	[DC]	[DC]
[FD(1) C2h]	[FD(1) C2h]	[PEC]	[PEC]
[FD(1) D3h]	[FD(1) D3h]	[ALIVE]*	[ALIVE]*
Stop	Stop	Stop	Stop
22 characters	22 characters	22 characters	22 characters

**If alive-counter mode is enabled.*

Table 56. READBLOCK Sequencing In Dual-UART Down Path (Block Size = 2)

HOST Tx	DEVICE RXU	DEVICE TXL	HOST Rx
Preamble	Preamble	Preamble	Preamble
{BS[4:0], 3b110}	{BS[4:0], 3b110}	{BS[4:0], 3b110}	{BS[4:0], 3b110}
[DEVICE ADDR]	[DEVICE ADDR]	[DEVICE ADDR]	[DEVICE ADDR]
[REG ADDR]	[REG ADDR]	[REG ADDR]	[REG ADDR]
[DC]	[DC]	[DATA LSB]	[DATA LSB]
[PEC]	[PEC]	[DATA MSB]	[DATA MSB]
[ALIVE]*	[ALIVE]*	[DC]	[DC]
[FD(1) C2h]	[FD(1) C2h]	[PEC]	[PEC]
[FD(1) D3h]	[FD(1) D3h]	[ALIVE]*	[ALIVE]*
Stop	Stop	Stop	Stop
18 characters	18 characters	18 characters	18 characters

*If alive-counter mode is enabled.

Table 57. READBLOCK Sequencing In Single-UART or Dual-UART Down Path (Block Size = 2)

HOST Tx	DEVICE RXU	DEVICE TXL	HOST Rx
Preamble	Preamble	Preamble	Preamble
{BS[4:0], 3b110}	{BS[4:0], 3b110}	{BS[4:0], 3b110}	{BS[4:0], 3b110}
[DEVICE ADDR]	[DEVICE ADDR]	[DEVICE ADDR]	[DEVICE ADDR]
[REG ADDR]	[REG ADDR]	[REG ADDR]	[REG ADDR]
[DC]	[DC]	[DATA0 LSB]	[DATA0 LSB]
[PEC]	[PEC]	[DATA0 MSB]	[DATA0 MSB]
[ALIVE]*	[ALIVE]*	[DATA1 LSB]	[DATA1 LSB]
[FD(1) C2h]	[FD(1) C2h]	[DATA1 MSB]	[DATA1 MSB]
[FD(1) D3h]	[FD(1) D3h]	[DC]	[DC]
[FD(1) C2h]	[FD(1) C2h]	[PEC]	[PEC]
[FD(1) D3h]	[FD(1) D3h]	[ALIVE]*	[ALIVE]*
Stop	Stop	Stop	Stop
22 characters	22 characters	22 characters	22 characters

*If alive-counter mode is enabled.

byte (if enabled) is only incremented by the addressed device. A Manchester error immediately switches the data propagation from read mode to write (pass through) mode, ensuring that the Manchester error is propagated through the daisy-chain and back to the host.

DOWNHOST Command

Only one of the DUALUART paths (Up path or Down Path) can be granted WRITE access through using the UPHOST or DOWNHOST commands, however, both paths have read access. The path that holds the WRITE access is specified using the UARTHOST register bit. By default only the Up path has the WRITE access (UARTHOST=1b1). See [Table 58](#).

The DOWNHOST command is used when WRITE access is required to be passed from the Up path (UARTHOST = 1b1) to the Down path (UARTHOST=1b1). Alternatively, the UPHOST command is used when WRITE access is required to be passed from the Down path to the Up path. The UPHOST command is detailed in a different section.

When the DOWNHOST command is sent, each device modifies the UARTHOST bit in the DEVCFG1 register to change master control, as well as increments the DEVCOUNT variable as it sends the command to the next device downstream in the chain. The final value of DEVCOUNT received by the host should be equal to the initial DEVCOUNT + total number of devices in the chain. If the DOWNHOST command is sent on the Up path, the command passes through the device unmodified, leaving the UARTHOST unchanged; the ALRTDUALUART bit is also set in the STATUS2 register, signifying that an invalid command was received. Additionally, If the DOWNHOST command is sent on the Down path while the Down path is designated as the master, the command passes through the device unmodified, leaving the UARTHOST unchanged with the Down path indication.

Note: The DOWNHOST command is relevant only when the device is configured in dual-UART mode. Sending the DOWNHOST command outside of a dual-UART configuration will not have any effect on the device; the command is passed through, unchanging the DEVCOUNT.

UPHOST Command

Only one of the dual-UART paths (Up path or Down path) can be granted WRITE access through using the UPHOST or DOWNHOST commands; however, both paths have read access. The path that holds the write access is specified using the UARTHOST register bit. By default, only the Up path has write access (UARTHOST=1b1). See [Table 59](#).

The UPHOST command is used when write access needs to be passed from the Down path (UARTHOST=1b1) to the Up path (UARTHOST=1b1). Alternatively, the DOWNHOST command is used when write access needs to be passed from the Up path to the Down path. See the [DOWNHOST Command](#) section for further detail.

When the UPHOST command is sent, each device modifies the UARTHOST bit in the DEVCFG1 register to change master control, as well as increments the DEVCOUNT variable as it sends the command to the next device upstream in the chain. The final value of DEVCOUNT received by the host should be equal to the initial DEVCOUNT + total number of devices in the chain. If the UPHOST command is sent on the Down path, the command passes through the device unmodified, leaving the UARTHOST unchanged; the ALRTDUALUART bit will also be set in the STATUS2 register, signifying that an invalid command was received. Additionally, If the UPHOST command is sent on the Up path while the Up path is designated as the master, the command passes through the device unmodified, leaving the UARTHOST unchanged with the Up path indication.

Table 58. DOWNHOST Sequencing (z = Total Number of Devices)

HOST Tx	DEVICE (n) RXU	DEVICE (n) TXL	HOST Rx
Preamble	Preamble	Preamble	Preamble
09h	09h	09h	09h
00h	00h	00h	00h
{0b000,DEVCOUNT[4:0]}	{0b000,DEVCOUNT[4:0]+n-1}	{0b000,DEVCOUNT[4:0]+n}	{0b000,DEVCOUNT[4:0]+z}
Stop	Stop	Stop	Stop

Table 59. UPHOST Sequencing (z = total number of devices)

HOST Tx	DEVICE (n) RXL	DEVICE (n) TXU	HOST Rx
Preamble	Preamble	Preamble	Preamble
08h	08h	08h	08h
00h	00h	00h	00h
{0b000,DEVCOUNT[4:0]}	{0b000,DEVCOUNT[4:0]+n-1}	{0b000,DEVCOUNT[4:0]+n}	{0b000,DEVCOUNT[4:0]+z}
Stop	Stop	Stop	Stop

Table 60. ALERTPACKET Sequencing

ALERT PACKET
Preamble
Command Byte (0x21)
Module Alert Location 1 {(DA[4:7]), (DA[0:3])}
Module Alert Location 2 {(DA[12:15]),(DA[8:11])}
Module Alert Location 3 {(DA[20:23]),(DA[16:19])}
Module Alert Location 4 {(DA[28:31]),(DA[24:27])}
[STATUS LSB]
[STATUS MSB]
[PEC]
Stop

Note: The DOWNHOST command is relevant only when the device is configured in dual-UART mode. Sending the DOWNHOST command outside of a dual-UART configuration will not have any effect on the device; the command is passed through unchanging the DEVCOUNT.

ALERTPACKET Command

The MAX17853 supports the transmission of an ALERT packet from either the host microcontroller or SPI to UART bridge. This packet contains the alert command byte, daisy-chain module alert data-address location (DA[4:0]), and alert status byte, as well as the PEC byte of the protected data (see [Table 60](#)).

The module alert location is a 32-bit value split into four transmission data packets, where each bit represents the device address (DA[4:0]), defined by the HELLOALL command. The alert status is the 16-bit output of the STATUS1 register, subject to masking through ALRTIRQEN, as

described in the following sections. As the data passes through the daisy-chain, the module alert location contains a unique identifier; the STATUS output will be logically OR'ed to communicate the alert type. This creates a method to quickly assess the module status and health with little host interaction.

SPI Interface

When a single device is used in a single battery-pack application with no daisy-chain, the host can use the SPI interface to communicate with the device. The host should set UARTSEL low. When UARTSEL is set high, the device uses the UART interface to communicate with the microprocessor.

Overview

The MAX17853 SPI interface is SPI/QSPI™/Microwire/DSP compatible, ensuring compatible operation with standard microcontrollers (μCs) from a variety of manufacturers.

The μC always operates as the master and is able to initiate read and write transactions to individual slave devices selected by a specific CSB connection. The operation and timing criteria of the SPI interface is shown in Figure 65. The MAX17853 will be programmed by a qualified 32-cycle SPI instruction framed by a CSB low interval.

The SCLK line should be driven by the master and distributed to all slave devices. Only the slave device with its

CSB line held low will accept SCLK SPI transactions to the slave devices are defined by SCLK rising edges. The start of the transaction is defined by the SCLK rising edge, following the CSB falling edge (subject to t_{CSH0} and t_{CSS0} timing criteria). Transactions including a number of SCLK rising edges not equal to 32 will not be qualified for execution (also based on t_{CSA} , t_{CSH1} , and t_{CSQ} timing criteria). Qualified transactions will be executed on the rising edge of CSB. To abort a transaction sequence, the rise of CSB must precede a qualified (32nd) rising edge of SCLK (meeting the t_{CSA} timing requirement). **Note:** An aborted command will result in the issuance of an SPI CLK Error.

The SDI line should be hooked up to a master-out/slave-in (MOSI) port and distributed to all slave devices. SDI data is latched into the selected slave device on SCLK rising edges, subject to setup and hold criteria (t_{DS} , t_{DH}). The SDI content of the SPI transaction consists of 4 bytes for qualified transactions.

The SDO line should be hooked up to a master-in/slave-out (MISO) port and distributed to all slave devices. SDO is actively driven by the selected slave device when CSB falls (t_{DOE} timing applies), initially presenting the MSB of the output data (the SPI_CRC_ERR bit for all transactions). Following the initial SCLK rising edge, SDO is updated in response to SCLK falling edges, conforming to hold and transition time criteria (t_{DOH} , t_{DOT}), allowing

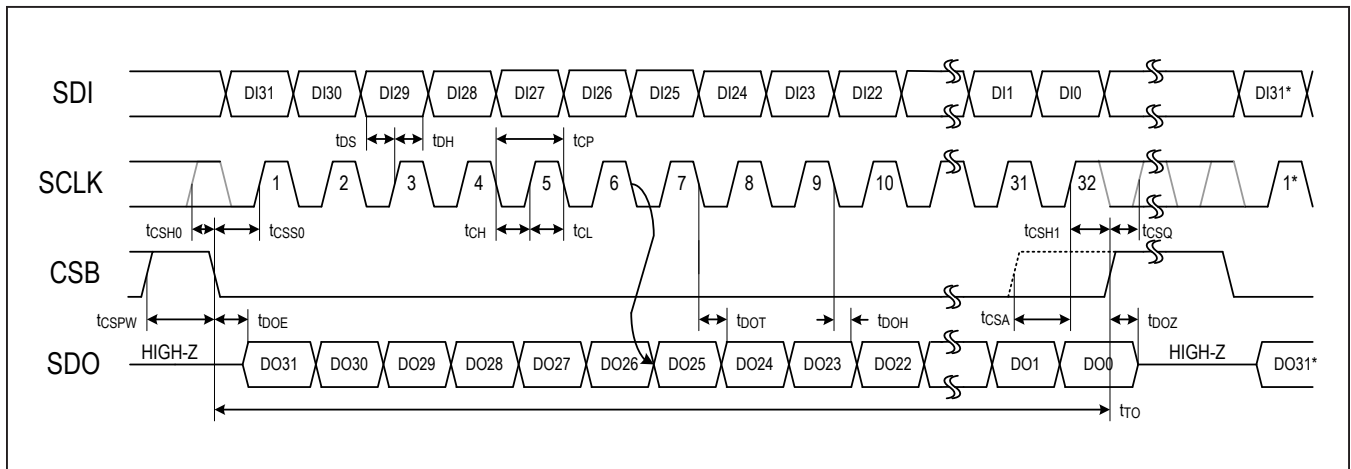

Figure 65. SPI Timing Diagram

QSPI is a trademark of Motorola, Inc.

the μC to latch the data on SCLK rising edges. When CSB is high, the SDO line is high-impedance, allowing other slave devices to access the SDO bus.

Transactions lasting longer than the timeout interval (t_{TO}), measured from CSB falling edge to CSB rising edge are not qualified or executed.

System-Level Connection

Following the previous guidelines, the SPI interface allows multiple devices to share the SPI interface with the active device for the transaction being selected, by pull-

ing its unique CSB port low. Note that each slave device on the interface requires a dedicated CSB line from the master. The SCLK, SDI, and SDO lines are common to all devices. A total of $(3+N)$ lines is required for an interface supporting N slave devices. Transaction qualification criteria remain in effect; in write mode, the device will only execute instructions exactly 32 bits in length. In read mode, return the requested data through SDO during the read-mode transaction. A standard connection example is shown in [Figure 66](#).

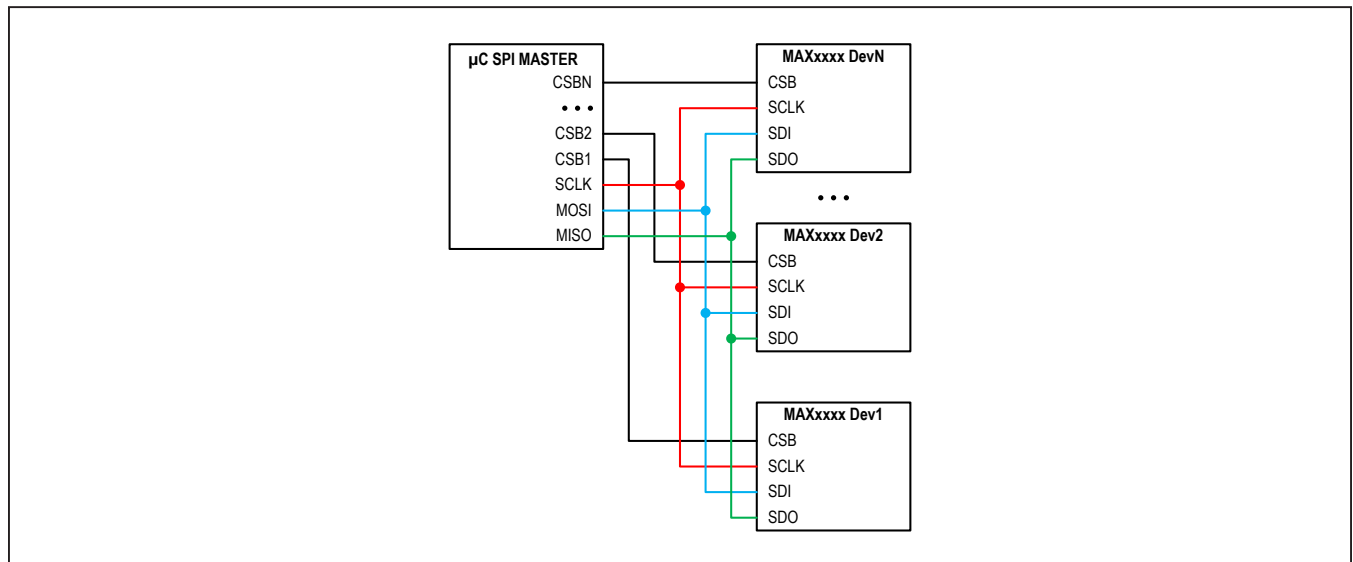

Figure 66. SPI Device Connection

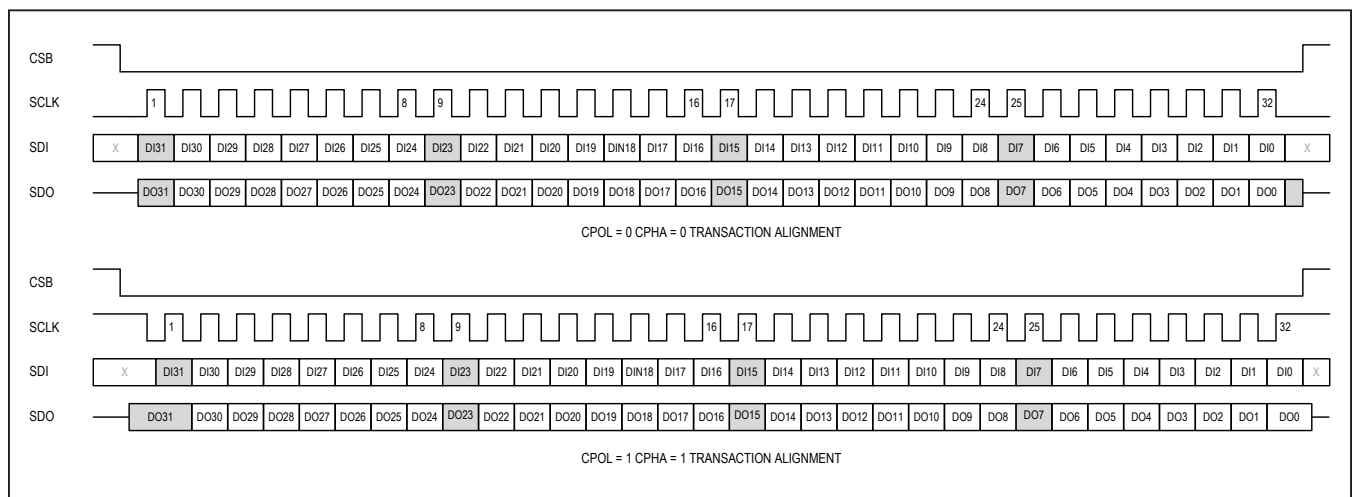

Figure 67. SPI Supported Transaction Alignments

Supported Transaction Alignments

The MAX17853 is capable of supporting SPI transactions with masters using either (CPOL=0 and CPHA=0) or (CPOL=1 and CPHA=1). Examples of these transactions are shown in [Figure 67](#).

Safety Pulup/Pulldown Resistors

To guard against broken SPI interface connections, the MAX17853 includes internal safety terminations on all SPI interface input ports. SCLK and SDI have internal pulldowns to GND. CSB has an internal pulup to V_{DDL3}. All safety resistors are 100kΩ (nom).

The internal safety resistors can be individually enabled or disabled using DEVCFG1 register bits (SFTYSCLK, SFTYSDI, SFTYCSB) with a high state (default) to indicate the safety termination is enabled/engaged and a low state to indicate it is disengaged. This allows the user to eliminate loading currents when the safety resistors are not needed. Note pulup resistors still have a resistor and diode connection to V_{DDL3} even if disengaged (limiting CSB voltage to V_{DDL3} + 0.3V to avoid conduction).

SPI Transactions

SPI Write-Mode Transactions

A properly constructed write-mode transaction is made up of a 32-bit data frame. Each SDI data frame from the master contains a R/WB=0 bit, an 8-bit command/address, a 3-bit CRC covering the command/address, 2 bytes of input data, a confirmation of the R/WB=0 bit, and a 3-bit CRC covering the input data.

During a write-mode transaction, the MAX17853 outputs data on the SDO line confirming device status, as well as the command/address and input data received. Each SDO data frame from the slave contains 5 bits of status information protected by a 3-bit CRC followed by a 24-bit direct readback of the command/address and input data received during the transaction. Note that while the 24-bit readback is not CRC protected, the transaction can be verified with 100% confidence since the master knows

exactly what data was sent to the device during the transaction.

The MAX17853 will only accept and execute qualified SPI transactions based on the 32 bits of SDI data received and several interface integrity checks. Details of write-mode transactions are explained below and summarized in [Figure 68](#).

SPI Write-Mode Input Data Format

During write-mode transactions, the MAX17853 accepts qualified instructions through the SDI input, described as follows. If more than 32 SCLK cycles are provided in the transaction, the device ignores the excess data provided during the remaining clock cycles, the transaction is ignored, and an SPI clock error issued.

An SPI error due to frame length sets the ALRTINTRFC and ALRTSPI bits in the STATUS1 and STATUS2 registers, respectively, as well as the CLK_ERR diagnostic bit (DO[28]) present in every SPI frame.

Write Bit — R/WB = 0 (DI[31])

Write-mode transactions are identified by R/WB = 0 in MSB position of the 32-bit data frame

Address — A[7:0] (DI[30:23])

Write-mode transactions allow new information to be written to internal configuration/command registers within the device. The register address to be written is indicated by A[7:0] within the data frame.

Address Cyclic-Redundancy Check — CRCA[2:0] (DI[22:20])

Write-mode command/address data transactions are protected by a 3-bit CRC with polynomial 0x5 (x³+x+1). A total of 9 bits are protected, yielding a Hamming distance of 2 (HD = 2). The CRCA check is calculated over the following bits: R/WB + A[7:0] (i.e., positions DI[31:23]), confirming the integrity of the incoming command. The master must embed the correct CRCA value within each data frame in positions DI[22:20] for the transaction to qualify for execution. The receiving slave will only accept/execute

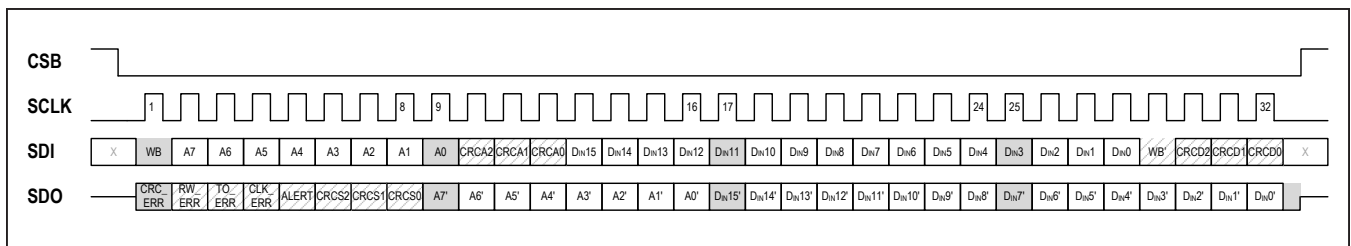

Figure 68. SPI Write-Mode Transaction Format

the transaction if the CRCA check is passed; otherwise, the transaction is ignored and an SPI CRC error issued.

SPI errors caused by CRCA failures set the ALRTPEC bit in the STATUS1 register, as well as the CRC_ERR diagnostic bit (DO[31]) present in every SPI frame.

Input Data — DIN[15:0] (DI[19:4])

These 2 bytes of input data in the 32-bit data frame represent data that will be written to the requested register, or describes internal operations to be executed.

Repeated-Write Bit — R/WB' = 0 (DI3)

Write-mode transactions are confirmed by a repeated R/WB = 0 in position DI[3] of the bit data frame. If the data in positions DI[31] and DI[3] do not match, the transaction is ignored and an SPI RW error issued.

SPI errors caused by R/WB and R/WB' mismatches set the ALERTINTRFC and ALRTSPI bits in the STATUS1 and STATUS2 registers, respectively, as well as the RW_ERR diagnostic bit (DO[30]) present in every SPI frame.

Input Data Cyclic-Redundancy Check — CRCD[2:0] (DI[2:0])

Write-mode input data transactions are protected by a 3-bit CRC with polynomial $0x5 (x^3+x+1)$. A total of 16 bits are protected, yielding a Hamming distance of 2 (HD = 2). The CRCD check is calculated over the following bits: DIN[15:0] (i.e., positions DI[19:4]). The master must embed the correct CRCD value within each data frame in positions DI[2:0] for the transaction to qualify for execution. The slave only accepts/executes the transaction if the CRCD is passed; otherwise, the transaction is ignored and an SPI CRC error issued.

SPI errors caused by CRCD failures set the ALRTPEC bit in the STATUS1 register, as well as the CRC_ERR diagnostic bit (DO[31]) present in every SPI frame.

SPI Write-Mode Output Data Format

During write-mode transactions, the MAX17853 outputs data through the SDO line confirming both device status and the received instructions, as described below. If more than 32 SCLK cycles are provided in the transaction, the device will output zeros for the remaining cycles, the transaction will be ignored and an SPI clock error issued.

Status Information — STAT[4:0] (DO[31:27])

During write-mode transactions, the MAX17853 outputs status data through the SDO line confirming current device status. Since the STAT[4:0] information is identical for both read- and write-mode transactions, the definition of these bits is described in a common section that follows.

Status Cyclic-Redundancy Check — CRCS[2:0] (DO[26:24])

During write-mode transactions, the MAX17853 outputs status CRC data protecting the status information provided through SDO. Since the CRCS[2:0] information is identical for both read- and write-mode transactions, the definition of these bits is described in a common section that follows.

Address Confirmation — A'[7:0] (DO[23:16])

During write-mode transactions, the MAX17853 relays the incoming address (A[7:0]) data received through SDI in positions DO[23:16] through SDO. This behavior allows the master complete confirmation that what was sent through the SPI interface was accurately received by the device; as such, the write-mode confirmation data is not covered by a CRC. If any error is detected, the master should react accordingly, knowing that the flawed transaction may have been rejected if an SPI error condition was detected and/or the CRCA check on the incoming transaction did not pass.

Input Data Confirmation — DIN'[7:0] (DO[15:0])

During write-mode transactions, the MAX17853 relays the incoming input data (DIN[7:0]) received through the SDI in positions DO[15:0] through SDO. This behavior allows the master complete confirmation that what was sent through the SPI interface was accurately received by the device; as such, the write-mode confirmation data is not covered by a CRC. If any error is detected, the master should react accordingly, knowing that the flawed transaction may have been rejected if an SPI error condition was detected and/or the CRCD check on the incoming transaction did not pass.

SPI Write-Mode Qualification Checks

To qualify for write-mode execution, the following conditions must be met:

- SPI transaction must be exactly 32 bits in length (with no CLK_ERR recorded)
- CRCA address CRC check must pass (with no CRC_ERR recorded)
- CRCD input data CRC check must pass (with no CRC_ERR recorded)
- R/WB must match R/WB' (i.e., DI[31] = DI[3] (with no RW_ERR recorded)
- SPI transaction must be completed within the timeout interval (t_{TO} , with no TO_ERR recorded)

If the SPI transaction is qualified, the instruction will be executed, and the requested internal register contents updated, or the requested action performed.

If the SPI write transaction is not qualified, the instruction is not executed, and the appropriate SPI error diagnostic bits will be set. The SPI error diagnostic bits are returned in response to later read- and write-mode transactions, notifying the μ C that the SPI interface may be compromised.

SPI Read-Mode Transactions

A properly constructed read-mode transaction is made up of a 32-bit data frame. Each SDI data frame from the master contains a R/WB=1 bit, an 8-bit requested address, a 3-bit CRC covering the address, two bytes of input data = 0000\h, a confirmation of the R/WB=1 bit, and a 3-bit CRC covering the input data.

During a read-mode transaction, the MAX17853 outputs data on the SDO line confirming device status, and providing the data requested with full CRC protection. Each SDO data frame from the slave device contains 5 bits of status information protected by a 3-bit CRC, four ones (indicating a read operation is pending), followed by 16 bits of output data, and finally, a read-mode confirmation bit and a 3-bit CRC protecting the output data.

The MAX17853 will only accept and execute qualified SPI transactions, based on the 32 bits of SDI data received, and several interface integrity checks. Details of read-mode transactions are explained in following sections and summarized in [Figure 69](#).

SPI Read-Mode Input-Data Format

During read-mode transactions, the MAX17853 accepts qualified instructions through the SDI inputs, as described below. If more than 32 SCLK cycles are provided in the transaction, the device ignores the excess data provided during the remaining clock cycles, the transaction will be ignored, and an SPI Clock error issued.

An SPI error due to frame length sets the ALRTINTRFC and ALRTSPI bits in the STATUS1 and STATUS2 regis-

ters, respectively, as well as the CLK_ERR diagnostic bit (DO28) present in every SPI frame.

Read Bit — R/WB = 1 (DI[31]):

Read-mode transactions are identified by R/WB =1 in the MSB position of the 32-bit data frame.

Address — A[7:0] (DI[30:23])

Read-mode transactions fetch the information from the register requested by the address byte (A[7:0]). If the CRCA check fails, indicating a problem with the transaction or interface, the MAX17853 still reads back the data requested by A[7:0]. This may not be what the master intended, and the master will be notified of this through the read-mode confirmation bit (ROK, see following sections). Note that reading from a reserved address results in a read-back value of DOUT[15:0] = 0000\h.

Address Cyclic Redundancy Check — CRCA[2:0] (DI[22:20])

Read-mode command/address data transactions are protected by a 3-bit CRC with polynomial 0x5 (x^3+x+1). A total of 9 bits are protected, yielding a Hamming distance of 2 (HD=2). The CRCA check is calculated over the following bits: R/WB + A[7:0] (i.e., positions DI[31:23]), confirming the integrity of the incoming command. The master must embed the correct CRCA value within each data frame in positions DI[22:20] for the transaction to qualify for execution. The receiving slave device will only accept/execute the transaction if the CRCA is passed; otherwise, the transaction is ignored and an SPI CRC error issued.

SPI errors caused by CRCA failures set the ALRTPEC bit in the STATUS1 register, as well as the CRC_ERR diagnostic bit (DO[31]) present in every SPI frame.

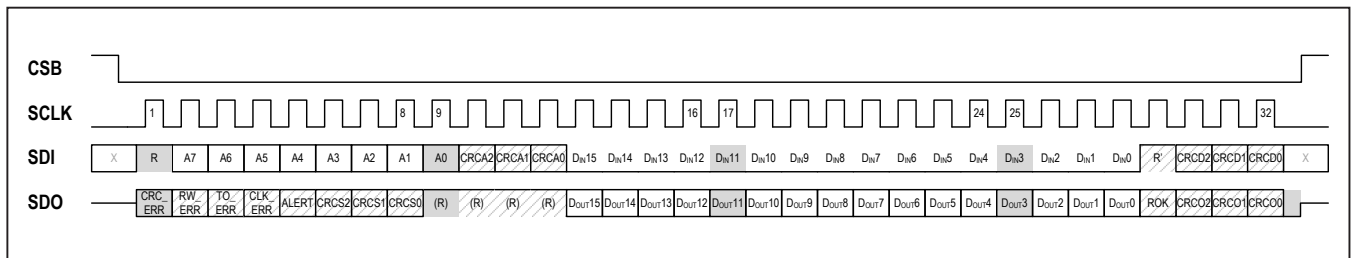

Figure 69. SPI Read-Mode Transaction Format

Input Data — DIN[15:0] (DI[19:4])

These 2 bytes of input data in the 32-bit data frame must be set to zero (0000h); otherwise, the transaction is ignored and an SPI error issued.

SPI errors generated by read transactions with non-zero input data set the ALERTINTRFC and ALRTSPI bits in the STATUS1 and STATUS2 registers, respectively, as well as the RW_ERR diagnostic bit (DO[30]) present in every SPI frame.

Repeated-Read Bit — R/WB' = 1 (DI[3])

Read-mode transactions are confirmed by a repeated R/WB=1 in position DI[3] of the bit data frame. If the data in positions DI[31] and DI[3] do not match, the transaction is ignored and an SPI RW error issued.

SPI errors caused by R/WB and R/WB' mismatches set the ALERTINTRFC and ALRTSPI bits in the STATUS1 and STATUS2 registers, respectively, as well as the RW_ERR diagnostic bit (DO[30]) present in every SPI frame.

Input-Data Cyclic-Redundancy Check – CRCDD[2:0] (DI[2:0])

Read-mode input-data transactions are protected by a 3-bit CRC with polynomial $0x5 (x^3+x+1)$. A total of 16 bits are protected, yielding a Hamming distance of 2 (HD = 2). The CRCDD check is calculated over the following bits: DIN[15:0] (i.e., positions DI[19:4]). The master must embed the correct CRCDD value within each data frame in positions DI[2:0] for the transaction to qualify for execution. The slave will only accept/execute the transaction if the CRCDD is passed; otherwise, the transaction is ignored and an SPI CRC error issued.

SPI errors caused by CRCDD failures set the ALRTPEC bit in the STATUS1 register, as well as the CRC_ERR diagnostic bit (DO[31]) present in every SPI frame.

SPI Read-Mode Output-Data Format

During read-mode transactions, the MAX17853 outputs data through the SDO line, confirming device status and the requested output data, described as follows. If more than 32 SCLK cycles are provided in the transaction, the device outputs zeros for the remaining cycles, the transaction is ignored, and an SPI clock error issued.

Status Information – STAT[4:0] (DO[31:27])

During read-mode transactions, the MAX17853 output status data through the SDO line confirming current device status. Since the STAT[4:0] information is identical for both read and write-mode transactions, the definition of these bits is described in a common section below.

Status Cyclic-Redundancy Check — CRCS[2:0] (DO[26:24])

During read-mode transactions, the MAX17853 outputs status CRC data, protecting the status information provided through SDO. Since the CRCS[2:0] information is identical for both read- and write-mode transactions, the definition of these bits is described in a common section that follows.

Read Confirmation Bits — Fh (DO[23:20])

During read-mode transactions, the MAX17853 relays four ones in the DO[23:20] position, indicating the R/WB bit received was a one and a read-mode transaction has been requested. Since all addresses above 0x98 are reserved, seeing all ones in this position during a WRITEMODE command indicates an interface or protocol fault. Likewise, seeing anything but all ones in this position during a read-mode command indicates the R/WB was not received or the interface is compromised. If either error is detected, the master should react accordingly, knowing that the flawed transaction may have been rejected if an SPI error and/or CRC checks on the incoming transaction did not pass.

Output Data — DOUT[15:0] (DO[19:4])

During read-mode transactions, the MAX17853 relays the requested output data (DOUT[15:0]) in positions DO[19:4] through SDO.

Read OK Bit — ROK (DO[3])

During read-mode transactions, the MAX17853 relays a 1 in the DO3 position, indicating a read-mode transaction is in progress and the CRCA check has passed. This, combined with the read-confirmation bits in positions DO[23:20] allows the master to confirm the data received matches the address requested.

Output-Data Cyclic-Redundancy Check — CRCO[2:0] (DO[2:0])

Read-mode output data transmissions are protected by a 3-bit CRC with polynomial $0x5 (x^3 + x + 1)$. A total of 16 bits are protected, yielding a Hamming distance of 2 (HD = 2). The CRC check is calculated over the following bits: DOUT[15:0] (i.e., positions DO[19:4]). The MAX17853 will embed the correct CRC value within each data frame in positions DO[2:0] for the transaction to be qualified by the master. The master should only accept the output data as valid if the CRCO check passed; otherwise, the data should be considered compromised.

SPI Read-Mode Qualification Checks

To qualify for read-mode execution, the following conditions must be met:

- SPI transaction must be exactly 32 bits in length (with no CLK_ERR recorded)
- CRCA address CRC check must pass (with no CRC_ERR recorded)
- CRCD input data CRC check must pass (with no CRC_ERR recorded)
- R/WB must match R/WB' (i.e., DI[31] = DI[3]) (with no RW_ERR recorded)
- DIN[15:0] must match the required value of 0000h (with no RW_ERR recorded)
- SPI transaction must be completed within the timeout interval, t_{TO} (with no TO_ERR recorded)

Since the full SPI transaction cannot be fully qualified until it is completed, the MAX17853 responds to all read-mode transactions as received, providing the requested output data within the frame, based on the received value of A[7:0]; however, if the command in its entirety is found to fail any qualification check, the command will be rejected, which means any clear-on-read behaviors expected will not be executed internally.

In addition, if the SPI write transaction is not qualified, the appropriate SPI error diagnostic bits will be set. The SPI error diagnostic bits will be returned in response to later read- and write-mode transactions, notifying the μ C that the SPI interface may have been compromised.

General-Transaction Information (SPI)

The following sections describe behaviors common to both read- and write-mode transactions.

Status and Status CRC Output Data

The MAX17853 provides status (STAT[4:0]) and status CRC (CRCS[2:0]) data through SDO during the MSByte of each SPI transaction. The content is identical for both read- and write-mode transactions (defined as follows):

Status Information — STAT[4:0] (DO[31:27])

The MAX17853 provide the following SPI error diagnostic bits and alerts during both read- and write-mode transactions.

- **SPI CRC_ERR (STAT4)** Indicates a previous transaction was rejected due to a CRC failure for checks CRCA or CRCD.
- **SPI RW_ERR (STAT3)** Indicates a previous

transaction was rejected due to one or more of the following errors:

- Repeated R/WB mismatch, R/WB \neq R/WB' (i.e., DI[31] \neq DI[3], protocol error)
- DIN[15:0] \neq 0000h for any read-mode transaction (protocol error)
- **SPI TO_ERR (STAT2)** Indicates a previous transaction was rejected due to a timeout violation
- **SPI CLK_ERR (STAT1)** Indicates a previous transaction was rejected due to one or more of the following conditions:
 - Number of SCLK cycles was not exactly 32 (ALRTSCLKERR)
 - 16MHz HF OSC is halted or drifting severely (ALRTOSC3)
 - Expected transfer to the internal memory bus has failed (ALRTINTBUS)
- **ALERT (STAT0)** Indicates one or more alert conditions exist in the STATUS or FMEA registers

If multiple SPI Protocol errors occur during a single transaction, only the first error will be reported in the following order of precedence: CLK_ERR (ALRTSCLKERR), CRC_ERR, RW_ERR. SPI Timeout Errors, TO_ERR, and Internal Clock Errors, CLK_ERR (ALRTOSC3 and ALRTINTBUS) Can be reported with other errors occurring in the same transaction. This is done to aid identification of root cause. For example, a malformed transaction 33 SCLK cycles in length would fail the clock check, but may also fail CRC and address checks since the data is also likely misaligned as a result. In such a case, only the CLK_ERR SPI diagnostic bit would be set, due to precedence.

All SPI diagnostic bits are "Write 0 to Clear," meaning once asserted, they continue to read back as high until the content is cleared by writing 1'b0 to the particular status register bit: ALRTSPI (clear CRC_ERR, RW_ERR, and TO_ERR), component bits in STATUS2 clear individual components of CLK_ERR. The MAX17853 keeps a cumulative list of all SPI failure types observed during failed transactions until the readback is performed.

Note: The SPI CRC_ERR condition is reported using the dedicated STATUS1:ALRTPEC bit (read only), but is cleared using the STATUS2:ALRTSPI (i.e., the CRC_ERR condition is not reported in ALRTSPI). To clear ALRTPEC, it may be necessary to write ALRTSPI to zero even if it is already zero (if no other SPI errors are reported).

All device STATUS alert bits remain asserted (and thus the ALERT interface remains asserted), until the content is cleared by the proper operations. See STATUS register definitions for specific details.

Note that transactions processed after any SPI diagnostic or device alert bit are set and remain high will be qualified and executed/accepted as defined under normal operation—a previous/uncleared error condition does not prevent further transactions from being executed.

SPI ALERT Bit-Masking Operations

Assertion of the SPI ALERT Status bit (STAT0, DO27) is based on the contents of the STATUS1 register. Individual alert conditions can be masked out of the SPI Alert bit using settings in ALRTIRQEN; however, the underlying alert information will always be available for readback in the STATUS1 register.

SPI ALERT =

ALRTRST or (ALRTMSMTCH & MSMTCHALRTEN) or
 (ALRTCELLOVST & CELLOVSTALRTEN) or
 (ALRTCELLUVST & CELLUVSTALRTEN) or
 (ALRTBLKOVST & BLKOVVALRTEN) or (ALRTBLKUVST & BLKUVVALRTEN) or
 (ALRTAUXOVST & AUXOVSTALRTEN) or
 (ALRTAUXUVST & AUXUVSTALRTEN) or
 (ALERTPEC & PECALRTEN) or (ALRTINTRFC & INTRFCALRTEN) or
 (ALRTCAL & CALALRTEN) or (ALRTCBAL & CBALALRTEN) or
 (ALRTFMEA1 & FMEA1ALRTEN) or (ALRTFMEA2 & FMEA2ALRTEN)

Note: STATUS1:ALRTRST indicates a POR condition, and thus cannot be masked. STATUS1:ALRTSCAN is a procedural notification bit and is intentionally not included

in the SPI ALERT bit; it is available for inclusion in the ALERT Interface, to support interrupt-driven applications.

Status Cyclic Redundancy Check — CRCS[2:0] (DO[26:24])

Status output-data content is protected by a 3-bit CRC with polynomial 0x5 (x³+x+1). A total of 5 bits are protected, yielding a Hamming distance of 2 (HD=2, meaning the CRC will reliably catch transactions with 2-bit errors or less). The CRCS check is calculated over the following bits: STAT[4:0] (i.e., positions DO[31:27]). The MAX17853 embeds the correct CRCS value within each data frame in positions DO[26:24] for the transaction to be qualified by the master. The master should only accept the status data as valid if the CRCS check is passed; otherwise, the data should be considered compromised.

SPI CRC Calculations

All SPI CRC calculations use the same polynomial and CRC calculation method. CRC operations on incoming SDI data streams (CRCA and CRCD) are performed by the MAX17853 and require the host to compute the required CRC Remainders for inclusion in the SDI input data stream. CRC operations on outgoing SDO data streams (CRCS and CRCO) are performed by the host, based on CRC Remainders supplied by the MAX17853. To support SPI CRC computations and checking, the host must implement a CRC-3 encoding and decoding algorithm based on the following polynomial (0x5):

$$P(x) = x^3 + x^1 + 1$$

This polynomial is capable of protecting the covered SPI content with a Hamming distance of two, meaning any combination of 2 bits of error or less is guaranteed to be identified. If more than 2 bits of error are encountered,

Table 61. SPI CRC Operation Summary

CRCN OPERATION	R/W TRANSACTION	COVERED DATA	DATA POSITION	TRANSACTION BIT MASK	CRCN REMAINDER	CRCN POSITION
Address (CRCA)	Read and Write	R/WB + A[7:0]	DI[31:23]	0xFF80_0000	CRCA[2:0]	DI[22:20]
Input Data (CRCD)	Read and Write	D _{IN} [15:0]	DI[19:4]	0x000F_FFF0	CRCD[2:0]	DI[2:0]
Status (CRCS)	Read and Write	STAT[5:0]	DO[31:27]	0xF800_0000	CRCS[2:0]	DO[26:24]
Output Data (CRCO)	Read only	D _{OUT} [15:0]	DO[19:4]	0x000F_FFF0	CRCO[2:0]	DO[2:0]

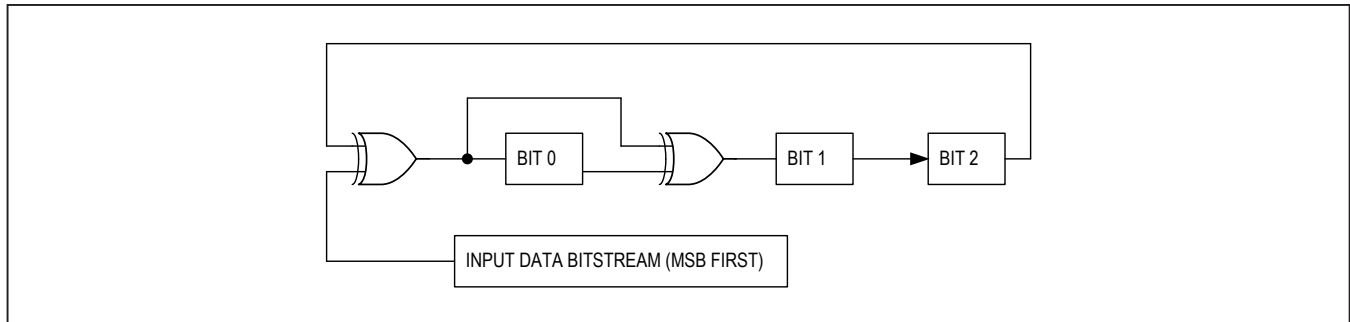

Figure 70. SPI CRC Calculation

the SPI CRC operation very likely identify the problem, though this cannot be mathematically guaranteed.

The list of CRCn operations and the effective bit-transaction masking operations are shown in Table 61. A hardware implementation of the CRC calculation is shown in Figure 70. The CRC Engine shown would be implemented within both MAX17853 and the host. Be sure to note the ordering of the bits within the Remainder, as shown in the figure (i.e. BIT[2:0] = CRCn[2:0]). All SPI CRC calculations are performed by supplying the MSB first, in the order presented in the SPI transaction.

For incoming SDI data streams, the MAX17853 will first clear the CRC Engine and then provide the covered bits within the incoming data stream into the the CRC Engine, MSB first. The host should perform the same operation in parallel. After the final bit of data is processed (in this case, the LSB of the incoming data stream is applied to the Engine), the Engine is stopped and the CRCn Remainder is known. The CRCn Remainder, as calculated by the host using its copy of the CRC Engine then follows within the SPI transaction (also MSB first), and is internally compared against the CRC Remainder as calculated by the MAX17853. If the CRCn Remainder received from the host matches the CRC Remainder calculated by the device for the incoming data stream, the CRC operation

is successful, and the transaction accepted and executed by the MAX17853. If there is a mismatch, the MAX17853 will reject the transaction and issue the SPI CRC_ERR status bit and STATUS1:ALRTPEC flag, notifying the host of the issue, so the transaction can be resent.

For outgoing SDO data streams, the MAX17853 first clears the CRC Engine and then provides the covered bits within the outgoing data stream into the the CRC Engine, MSB first. The host should perform the same operation in parallel. After the final bit of data is processed (in this case, the LSB of the outgoing data stream is applied to the Engine), the Engine is stopped and the CRCn Remainder is known. The CRCn Remainder, as calculated by the MAX17853 using its copy of the CRC Engine, then follows within the SPI transaction (also MSB first), for comparison against the CRC Remainder as calculated by the host. At this point, there are two equivalent ways the host can complete the CRCn operation to establish the validity of the received data:

- **Direct Comparison Method:** The host stops the CRC Engine once the data LSB is applied and compares the resulting CRCn Remainder to the Remainder supplied by the MAX17853 (again, MSB first). If the two Remainders match, the data is accepted as valid, otherwise it should be rejected. This is the method employed by the MAX17853 internally, as described above.

- Zero Remainder Method: The host continues CRC Engine computations after the data LSB is applied by appending the received Remainder to the end of the data stream, MSB first (i.e., in the order received during the SPI transaction). Once the LSB of the Remainder arrives at the input of the CRC Engine, if the resulting CRC Remainder=0h, the data is accepted as valid; otherwise, it should be rejected.

SPI CRC Pseudocode Example

```
Function SPI_CRC_Calculation(Data, CRC)
{
    //Data - the incoming data [MSB:LSB] for which CRC needs to be calculated
    //CRC - the calculated CRC that be returned by the function

    //Calculate length of incoming data
    //Data length is 5 for Status (CRCS), 9 for Address (CRCA), and 16 for
    Data (CRCD and CRCO)
    DataLength = Length(Data)
    //CRC polynomial = x^3 + x + 1
    POLY = 4'hB //Polynomial = 4'b1011
    //Append Data with 3 zeros for 3 bit CRC
    DataCalc = {Data, 3'b000}
    //Append zeros to POLY such that it is of the same length as DataCalc
    PolyZeros = {(DataLength + 3 - 4) 1'b0} //Data Calc length = DataLength
+ 3 //Since POLY = 4bits, subtract 4
    PolyCalc = {POLY, PolyZeros} //Append Zeros to POLY
    For Counter = (DataLength+3) to 4 //Counter decremented from
    MSB to LSB of Data
    (
    //Check MSB of DataCalc
    //If DataCalc[Counter] = 1'b1, bitwise XOR PolyCalc with DataCalc, and
    store result in DataCalc
    //If DataCalc[Counter] = 1'b0, skip the XOR operation
    //Circular Shift PolyCalc right by 1 bit every iteration.
    if(DataCalc[Counter] == 1'b1) Then
    DataCalc = DataCalc XOR PolyCalc
    End If
    )
}
```

```

PolyCalc = {PolyCalc[0],
PolyCalc[Length[PolyCalc]-1
: 1]} //Circular Shift Right
PolyCalc by 1 bit
)
Return DataCalc[3:1] //3
LSBs of DataCalc give the 3
bit CRC}
    
```

SPI Timeout Behavior

All SPI transactions are timed by an internal 16MHz oscillator and are measured from the falling edge of CSB initiating a transaction to the rising edge of CSB terminating a transaction. If the time out interval (t_{TO}) is exceeded by a transaction, the transaction be timed-out and not be qualified or executed.

If a transaction is paused/interrupted for any reason (defined by a cessation of SCLK activity), and later resumed under the same CSB low interval, the SPI interface continue to accept input data through SDI and relay the expected output data through SDO, as would normally be expected for the remainder of the transaction. However, even if all other qualification criteria are eventu-

ally met, the transaction not be qualified or executed, and the TO_ERR diagnostic bit be set.

In order to resolve a timed-out transaction and move forward with subsequent transactions, the timed-out transaction needs to be terminated by bringing CSB high. It is not necessary to complete the transaction by supplying 32 clocks; though if this is not done, the SPI CLK_ERR condition will be reported in addition to the TO_ERR condition. New transactions can then begin, initiated by pulling CSB low.

Alert Interface

The alert interface communicates the presence of a fault condition generated from the logical OR of the STATUS1 register, which flags any error within safety-critical functionality: voltage measurements, temperature measurements, interface-communication robustness, calibration, as well as other internal hardware diagnostics. Because the safety consideration per platform may differ, each of the associated alerts can be masked to provide individualized control. Additionally, the interface may be actively driven without the need of an actual alert condition to validate the functionality when commanded. This is done using the ALRTUSER bit in the FMEA2 register

Table 62. Alert-Interface Configuration in UART Mode

UARTCFG	UART CONFIGURATION	UART UP PATH	UART DOWN PATH	SINGLE ENDED ALERT
0b00	Single-UART interface with External Loopback	Active	Inactive (Buffered/Pass Through)	ALERTEN configured
0b01	Single-UART interface with Internal Loopback	Active	Inactive (Buffered/Pass Through)	ALERTEN configured
0b10	Single-UART interface with Differential Alert Interface	Active	Differential Alert	Disabled (except in ALRTDCTSTEN mode)
0b11	Dual-UART interface	Active	Active	ALERTEN configured

By default, the alert interface is a single-ended, unidirectional interface using the ALERTIN and ALERTOUT pins. The ALERTIN pin is configured as a single-ended UART receiver with RXP grounded (see the [UART Receiver](#) section for details). The ALERTOUT pin uses a single-UART transmitter as its output driver. If UARTSEL=0 (SPI interface), ALERTOUT becomes a DC active-low output that can be configured for open-drain (wired-OR) or CMOS operation. For UARTSEL=1 (UART interface), ALERTOUT is an AC CMOS output (see full details that follow).

Alternatively, a differential alert interface can be configured using the UARTCFG bits, as discussed in the [UART Interface](#) section and shown in [Figure 53](#). The Differential Alert interface allows for robust low-cost configurations using capacitive isolation to communicate the presence

of a fault, where the single-ended configuration allows for full UART flexibility and the need for a different isolation component (opto-isolators).

If the Hardware Alert interface is disabled, no alerts can be communicated through the hardware-interface options. The ALERTIN pin remain a high-impedance input and will not respond to any input. [Table 63](#) describes the configuration of the alert output drivers for both single-ended or differential alerts.

Note: Although the Hardware Alert interface can be disabled, the user still has the option to validate alerts by reading the STATUS registers, as well as the communication of the UART data-check byte or SPI Alert status bit.

Table 63. Alert Output Driver Configuration

UARTSEL	UARTCFG	SPIDRVINT	ALERTOUT ACTIVE/ASSERTED	ALERTOUT INACTIVE/ DEASSERTED OR ALERTEN=0
SPI (Pulldown)	Don't Care	0 (Open Drain)	0	Hi-Z
SPI (Pulldown)	Don't Care	1 (CMOS)	0	1
UART (Pullup)	0b00, 0b01, 0b11	Don't Care	AC Active	GND (TXLIDLEHIZ=0) Hi-Z (TXLIDLEHIZ=1)
UART (Pullup)	0b10 (Differential)	Don't Care	GND (TXLIDLEHIZ=0) Hi-Z (TXLIDLEHIZ=1)	GND (TXLIDLEHIZ=0) Hi-Z (TXLIDLEHIZ=1)
UART (Pullup) ALERTDCTSTEN=1	Don't Care	Don't Care	0	1

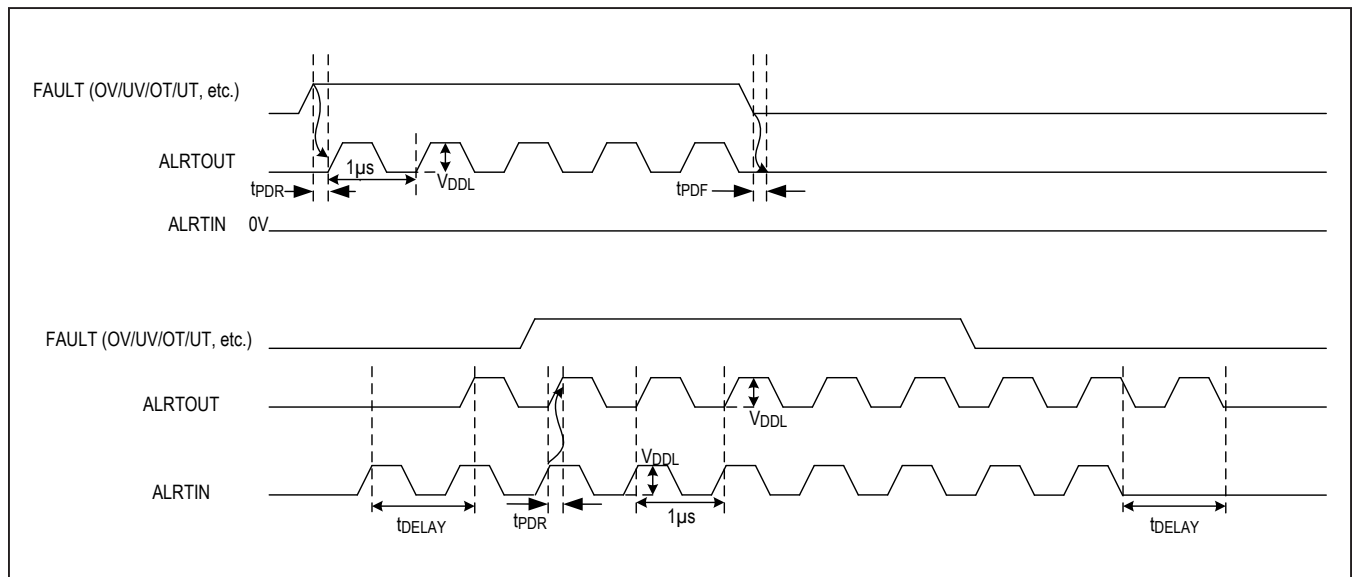

Figure 71. UART-Mode Alert-Detection Timing Diagram

UART-Mode Alert Detection (UARTSEL=1'b1)

This alert interface outputs a 2MHz continuous square wave with 50% duty cycle in the presence of a fault condition. The fault output persists for the duration of the fault and is updated at the rate determined by the scan mode. For a valid alert command to be recognized by the ALERTIN pin, the signal must be valid for 25µs and at the desired frequency. If the duration is shorter than the allocated time, or at a different frequency, this will not be recognized as a fault and the signal will not be propagated to the host. See [Figure 71](#) for a timing diagram.

In the absence of an alert, the output status depends on TXLIDLEHIZ-TXLIDLEHIZ=1'b1, with ALERTOUT driven Hi-Z, and TXLIDLEHIZ=1'b0, with ALERTOUT driven low.

SPI Mode Alert Operation (UARTSEL=1'b0)

When configured to communicate through the SPI interface (UARTSE=0), the ALERTOUT driver is reconfigured as an open-drain output or a CMOS output, depending on the SPIDRVINT selection. If an alert is present, the ALERTOUT output is driven active low. This is done to minimize power consumption of the application when configured as an open-drain output. If no ALERT condition is present, ALERTOUT is driven high (CMOS mode) or pulled high through an external connection to a pulup resistor for the open-drain configuration.

The open-drain configuration allows for the ALERTOUT signal to be logically OR'ed with any other signals at the application level to drive a host-controller interrupt.

Note: If an open-drain configuration, the voltage should not exceed V_{DDL2} .

In SPI mode, there are no daisy-chain devices, so any signal on the ALERTIN input is ignored.

Alert Interface Masking Operations

The Alert interface activity is based on the contents of the STATUS1 register. Individual alert conditions can be masked out of the Alert Interface using settings in ALRTIRQEN; however, the underlying alert information will always be available for readback in the STATUS1 register.

Active =

(ALRTSCAN & SCANALRTEN) or ALRTRST or
(ALRTMSMTCH & MSMTCHALRTEN) or

(ALRTCELLOVST & CELLOVSTALRTEN) or
(ALRTCELLUVST & CELLUVSTALRTEN) or

(ALRTBLKOVST & BLKOVVALRTEN) or (ALRTBLKUVST & BLKUVVALRTEN) or

(ALRTAUXOVST & AUXOVSTALRTEN) or
(ALRTAUXUVST & AUXUVSTALRTEN) or
(ALERTPEC & PECALRTEN) or (ALRTINTRFC & INTRFCALRTEN) or

(ALRTCAL & CALALRTEN) or (ALRTCBAL & CBALALRTEN) or

(ALRTFMEA1 & FMEA1ALRTEN) or (ALRTFMEA2 & FMEA2ALRTEN)

Note: ALRTRST indicates a POR condition, and thus cannot be masked.

Alert Packet Status Masking

The UART Alert packet content is based on the contents of the STATUS1 register. Individual alert conditions can be masked out of the Alert packet using settings in ALRTIRQEN register; however, the underlying alert information always be available for read back in the STATUS1 register. The masking operations for each STATUS1 bits is detailed below:

ALRT_PKT_STAT[15] = 0

ALRT_PKT_STAT[14] = ALRTRST

ALRT_PKT_STAT[13] = (ALRTMSMTCH & MSMTCHALRTEN)

ALRT_PKT_STAT[12] = (ALRTCELLOVST & CELLOVSTALRTEN)

ALRT_PKT_STAT[11] = (ALRTCELLUVST & CELLUVSTALRTEN)

ALRT_PKT_STAT[10] = (ALRTBLKOVST & BLKOVVALRTEN)

ALRT_PKT_STAT[9] = (ALRTBLKUVST & BLKUVVALRTEN)

ALRT_PKT_STAT[8] = (ALRTAUXOVST & AUXOVSTALRTEN)

ALRT_PKT_STAT[7] = (ALRTAUXUVST & AUXUVSTALRTEN)

ALRT_PKT_STAT[6] = 0

ALRT_PKT_STAT[5] = (ALRTPEC & PECALRTEN)

ALRT_PKT_STAT[4] = (ALRTINTRFC & INTRFCALRTEN)

ALRT_PKT_STAT[3] = (ALRTCAL & CALALRTEN)
 ALRT_PKT_STAT[2] = (ALRTCBAL & CBALALRTEN)
 ALRT_PKT_STAT[1] = (ALRTFMEA1 & FMEA1ALRTEN)
 ALRT_PKT_STAT[0] = (ALRTFMEA2 & FMEA2ALRTEN)

Note: STATUS1[15]:ALRTSCAN is a procedural notification bit and is intentionally not included in the UART Alert packet; it is available for inclusion in the Alert interface, to support interrupt-driven applications. STATUS1[14]:ALRTRST indicates a POR condition, and thus cannot be masked.

Alert-Masking TOPCELL1/2

If the battery stack contains less than 14 cells and the Flexible Pack configuration is not enabled, the lowest order inputs (e.g., C1 and C0) should be utilized first and connected to the lowest common-mode signals. Any unused cell inputs should be shorted together and unused switch inputs should be shorted together. The TOPCELL1 and TOPCELL2 registers mask all ALRTBALSW diagnostics from being reported.

All selections are supported for this function; if TOPCELL2 is not equal to TOPCELL1, no alerts are masked.

Table 64. Low-Voltage Regulator Operating Characteristics

INPUT:	DCIN
Input Voltage:	9V to 65V
Output:	V _{AA}
Output Voltage:	3.3V
Disable:	V _{SHNDL} < 0.6V or T _{DIE} > 145°C

Table 65. Low-Voltage Regulator Diagnostic

FAULT	CONDITION	ALERT	LOCATION
V _{AA} undervoltage	V _{AA} < 2.95V	ALRTRST	STATUS1

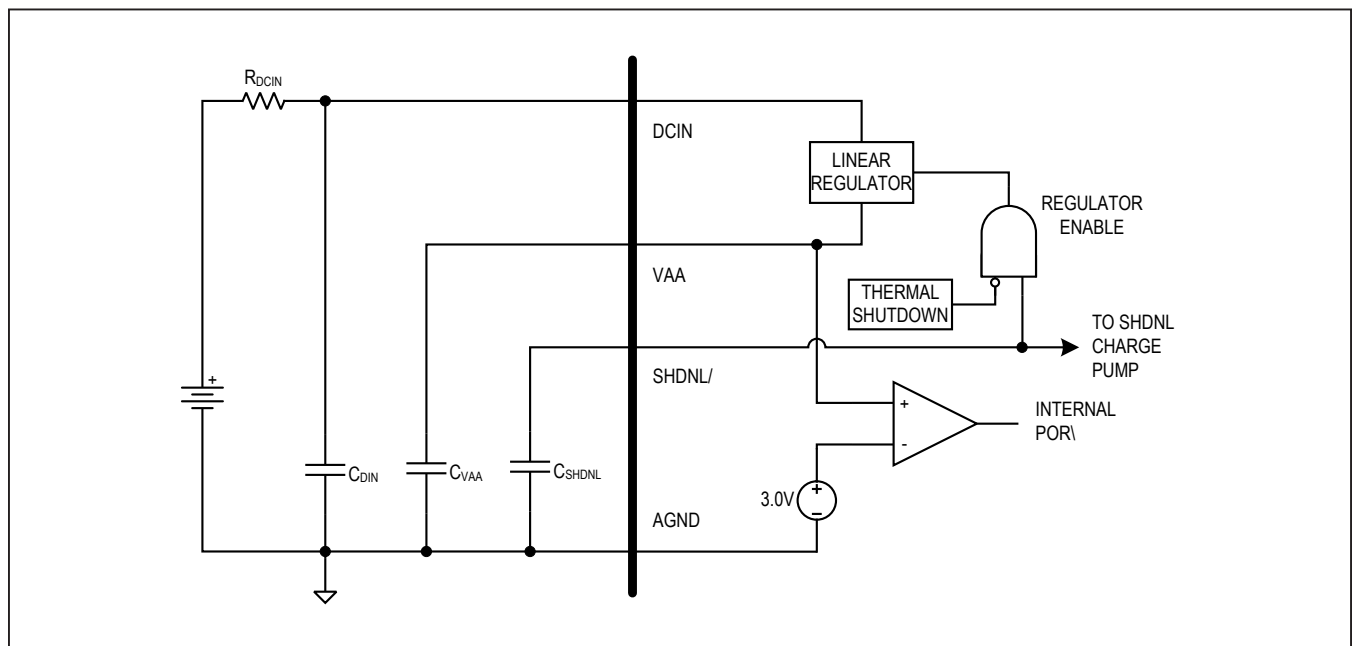

Figure 72. Low-Voltage Regulator and Thermal-Shutdown Circuit

Low-Voltage Regulator

An internal linear regulator supplies low-voltage power (V_{AA}) for the ADC and digital logic. The regulator is disabled when SHDNL is active-low or when the die temperature (T_{DIE}) exceeds 145°C . Once V_{AA} decays below 2.95V (typ), an internal power-on reset (POR) will be generated, as summarized in [Table 64](#) and shown in [Figure 72](#). This POR event can be detected with the ALRTRST bit, as shown in [Table 65](#). After a thermal shutdown, the regulator will not be enabled until $T_{DIE} < 130^{\circ}\text{C}$ due to hysteresis.

HV Charge Pump

The high-voltage multiplexers must be powered by a supply higher than any monitored voltage. As such, an internal charge pump draws power from the DCIN pin to provide a high-voltage supply (V_{HV}) that is regulated to $V_{DCIN} + V_{HV-DCIN}$. When the charge pump achieves regulation ($V_{HV-DCIN}$), charge pumping stops until the voltage drops by 20mV . The charge pump is automatically disabled during shutdown.

During the measurement cycle for ADC, comparator, ADC+COMP, and calibration, the charge pumping is paused to eliminate any potential impact of the charge-pump noise within the measurements. The charge pump then become active, operating on an 83kHz clock, during an inter-charge time (defined as the time between consecutive scan sequences), which lasts for $57\mu\text{s}$ on the ADC, comparator, and ADC+COMP. During calibration, the inter-charge time is reduced to $21\mu\text{s}$. The inter-charge time ensures that the charge on the C_{HV} capacitor is

replenished prior to the next measurement cycle. See [Figure 73](#) for an example of an HV charge pump.

Note: The charge pump is operational during AUXTIME, CELLDLY, and SWDLY settling periods greater than $30\mu\text{s}$, which is considered a worst-settling delay for the SWN input.

Outside of an acquisition, the charge pump is clocked at 32kHz .

An undervoltage comparator detects if $V_{HV-DCIN}$ drops below V_{HVUV} . If an undervoltage is detected, the ALRTHVUV bitfield is set. Assertion of the ALRTHVUV bit is gated until ALRTRST is cleared for the first time following power-up.

An overvoltage comparator disables the charge pump when $V_{HV} - V_{DCIN}$ exceeds V_{HVVOV} . This condition is indicated by the ALRTHVOV bit in the FMEA1 register; the ALRTHVOV alert does not necessarily indicate a condition that affects measurement accuracy. HV charge-pump diagnostics are summarized in [Table 66](#).

If V_{HV} drops too low relative to the top-cell inputs, there is insufficient headroom to guarantee that the HVMUX switch resistance is sufficiently low, or enough headroom exists for the LSAMP1 and LSAMP2 inputs for an accurate acquisition of the channel. Headroom alerts are indicated with the ALRTHVDRM bit in the FMEA1 register.

The HV undervoltage and HV headroom-alert functions can be verified by disabling the HV charge pump (HVCPDIS=1) and allowing V_{HV} to decay while in acquisition mode.

Table 66. HV Charge-Pump Diagnostics

FAULT	CONDITION	ALERT BIT	LOCATION
V_{HV} undervoltage	$V_{HV} - V_{DCIN} < V_{HVUV}$	ALRTHVUV	FMEA1:ALRTHVUV
V_{HV} overvoltage	$V_{HV} - V_{DCIN} > V_{HVVOV}$	ALRTHVOV	FMEA1:ALRTHVOV
V_{HV} low headroom	$V_{HV} - V_{TOPCELL1/2} < V_{HVHDRAM}(\text{min})$	ALRTHVDRM	FMEA1:ALRTHVDRM

Table 67. Oscillator Diagnostics

FAULT	CONDITION	ALERT BIT	LOCATION
32.768kHz oscillator	$31.129\text{kHz} > f_{\text{osc}_32\text{k}} > 34.406\text{kHz}$	ALRTOSC1	FMEA1[15]
32.768kHz oscillator	$31.129\text{kHz} > f_{\text{osc}_32\text{k}} > 34.406\text{kHz}$	ALRTOSC2	FMEA1[14]
16MHz oscillator	$15\text{MHz} > f_{\text{osc}_16\text{M}} > 17\text{MHz}$	ALRTOSC3	STATUS2[5]

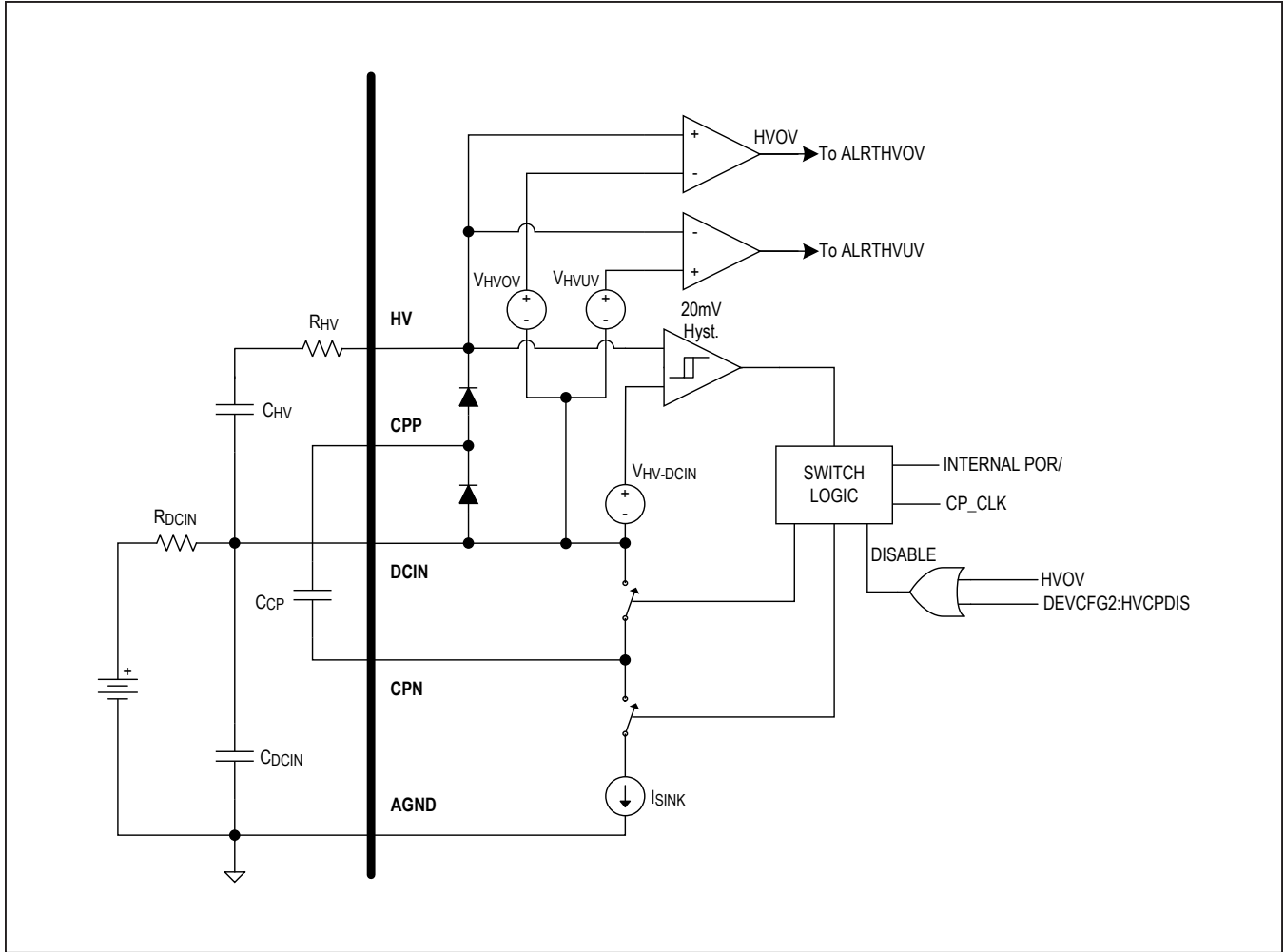

Figure 73. HV Charge Pump

Oscillators

Two factory-trimmed oscillators provide all timing requirements: a 16MHz oscillator for the UART and control logic, a 32.768kHz oscillator for the HV charge pump and timers. A special diagnostic counter, clocked by the 16MHz signal, is employed to check the 32kHz oscillator. Every two periods of the 32kHz clock, the counter is sampled. If the count varies more than 5% from the expected value, the ALRTOSC1 bit is set (see [Table 67](#)). A redundant alert bit, ALRTOSC2 bit, increases the integrity level. If the 16MHz oscillator varies by more than 5%, for UART part, communication errors may be indicated. For SPI configuration, the ALRTOSC3 bit is set as shown in [Table 67](#).

Diagnostics

Built-in diagnostics support ISO 26262 (ASIL) requirements by detecting specific fault conditions (see [Table 68](#)). The device automatically performs some of the diagnostics while the host performs others during initialization (e.g., at key-on) or periodically during operation, as required by the application. Diagnostics performed automatically by the device are previously described in the relevant functional sections. A description of the diagnostics requiring specific configurations is provided in this section.

Note: Pin faults such as an open pin or adjacent pins shorted to each other must be detectable. Pin faults do not result in device damage but have a specific device

response such as a communication error, or are detectable through a built-in diagnostic. Analyzing the effect of pin faults is referred to as a pin FMEA. Contact Maxim Applications to obtain pin FMEA results.

ALERTOUT Pin-to-Pin Short Diagnostic

The UART Alert DC Diagnostic test is used to test the ALERTOUT pin for shorts to AUXIN0/GPIO0 pins. When UARTSEL=0b1 (UART mode), this test is enabled by setting the ALERTDCTSTEN bit to 0b1.

When the DC Diagnostic test is enabled, the ALERTOUT pin is driven low if an Alert condition is present, and driven high otherwise. The ALRTUSER bitfield can be written to exercise ALERTOUT in either direction. Neighboring pins such as AUXIN0/GPIO0 can be monitored directly or in diagnostic modes to detect a fault.

This function works in all UARTCFG modes, including the differential alert, which does not normally use the ALERTOUT pin. This setting has no impact in SPI mode (UARTSEL=0), the same functionality can be realized using SPIDRVINIT and ALRTUSER.

CELL Pin Open Diagnostics

If an input of the MAX17853 is disconnected from the cell input through any combination of mechanical failures, the position of the failure can be detected by performing cell open diagnostics. It is recommended that comparator

Table 68. Summary of Built-In Diagnostics

DIAGNOSTICS PERFORMED AUTOMATICALLY BY DEVICE WITH NO HOST INTERVENTION		
Fault	Diagnostic Procedure	Output
V _{AA} undervoltage	Continuous voltage comparison	ALRTRST
VHV undervoltage	Continuous voltage comparison	ALRTHVUV
VHV overvoltage	Continuous voltage comparison	ALRTHVOV
VHV low headroom	Voltage comparison (updated during measurement)	ALRTHVHDM
32kHz oscillator fault	Continuous frequency comparison	ALRTOSC1, ALRTOSC2
16MHz oscillator fault	Communication error checking	ALRTMAN, ALRTPAR, ALRTOSC3
Communication fault	Communication error checking	ALRTPEC, ALRTMAN, ALRTPAR
RX pin open/short	Verify RX mode after POR	ALRTCOMMSEUn/ALRTCOMMSELn
VDDLx pin open/short	Continuous voltage comparison	ALRTVDDLx
GNDLx pin open/short	Continuous voltage comparison	ALRTGNDLx
Die overtemperature	Temperature comparison	ALRTTEMP
Measurement accuracy	Accuracy comparison -updated after oversampled acquisition	ALRTCOMPACCOV/ALRTCOMPACCUV
Flex Pack fault	Continuous fault checking of Flexible Pack operation	ALRTDCINMUX

Table 68. Summary of Built-In Diagnostics (continued)

DIAGNOSTICS PERFORMED DURING ACQUISITION MODE AS SELECTED BY DIAGSEL OR SCANCFG (BALSW DIAGNOSTICS)			
FAULT	DIAGNOSTIC PROCEDURE	DIAGSEL[3:0] or SCANCFG	OUTPUT
Die Temp (PTAT) fault	Die Temperature (PTAT) Diagnostic	DIAGSEL1/2 = 1h	DIAGSEL1/2[15:0] = PTAT voltage
V _{AA} Voltage fault	V _{AA} Verification	DIAGSEL1/2 = 2h	DIAGSEL1/2[15:0] = V _{AA} voltage
Reference Voltage fault	ALTREF Verification	DIAGSEL1/2 = 3h	DIAGSEL1/2[15:0] = ALTREF voltage
Comp Cell Signal Path fault	Comp Signal Path Verification	DIAGSEL1/2 = 4h	DIAGSEL1/2[15:0] = COMP error voltage
Cell Gain Calibration fault	Cell Gain Calibration Verification	DIAGSEL1/2 = 5h	DIAGSEL1/2[15:0] = Calibration voltage (6/13)
Offset Calibration fault	Offset Calibration Verification	DIAGSEL1/2 = 6h	DIAGSEL1/2[15:0] = Calibration Offset Voltage (0V)
DAC bit stuck high	DAC 3/4 Scale	DIAGSEL1/2 = 7h	DIAGSEL1/2[15:0] = DAC Code 1772d
DAC bit stuck low	DAC 1/4 Scale	DIAGSEL1/2 = 8h	DIAGSEL1/2[15:0] = DAC Code 591d
NTC(THRM) Offset Calibration Fault	NTC(THRM) Offset Calibration Verification	DIAGSEL1/2 = 9h	DIAGSEL1/2[15:0] = Calibration offset error with THRM
ADC bit stuck high	Zero-Scale ADC diagnostic	DIAGSEL1/2 = Ah	DIAGSEL1/2[15:0] = ADC zero scale
ADC bit stuck low	Full-Scale ADC diagnostic	DIAGSEL1/2 = Bh	DIAGSEL1/2[15:0] = ADC full scale
LSAMP Offset too high	LSAMP offset diagnostic	DIAGSEL1/2 = Ch	DIAGSEL1/2[15:0] (LSAMP offset voltage)
Balancing switch short	BALSW diagnostic mode	SCANCFG = 4h	ALRTBALSW, FMEA1:ALRTBALSWSUM
Balancing switch open	BALSW diagnostic mode	SCANCFG = 5h	ALRTBALSW, FMEA1:ALRTBALSWSUM
Odd Cell sense-wire open	BALSW diagnostic mode	SCANCFG = 6h	ALRTBALSW, FMEA1:ALRTBALSWSUM
Even Cell sense-wire open	BALSW diagnostic mode	SCANCFG = 7h	ALRTBALSW, FMEA1:ALRTBALSWSUM
Procedural Diagnostics: Contact Maxim Applications for the complete listing of procedural diagnostics found in the safety manual.			

measurements be used for quick identification against the default threshold setting, COMPOPNTH. If measurement is below the set threshold, the corresponding CELL alerts are flagged in ALRTCOMPOV.

Enable this diagnostic by setting CELLOPNDIAGSEL=1 and performing a comparator scan (SCANCFG=0b010). Only unipolar measurements are allowed for this diagnostic; if a cell position is set as bipolar, the corresponding cell is skipped and an alert flag is not set for that bipolar cell. Normally in open-diagnostic modes, pulldown current sources are enabled on all measured channels using CTSTEN for required cells. Various current configuration settings are available for the user and can be configured using the DIAGCFG:CTSTDAC bit field.

Die-Temperature Measurement

The die-temperature measurement allows the host to compute the device temperature (T_{DIE}) as it relates to the acquisition accuracy, and allows the device to automatically shut itself down when $T_{DIE} > 145^{\circ}\text{C}$. The measurement employs a source where voltage (V_{PTAT}), is proportional to absolute temperature (PTAT), as shown in [Figure 74](#). The V_{PTAT} measurement is enabled by setting DIAGSEL1[3:0] or DIAGSEL2[3:0] to 0b0001, with the 14-bit measurement stored in DIAG1=DIAG1REG[15:2] or DIAG2=DIAG2REG[15:2], respectively. The die-temperature measurement requires a settling time of 39 μs from the start of the measurement cycle until the diagnostic conversion. As long as two or more cell measurements are enabled, there will be sufficient settling time for this

measurement. See the various acquisition timing sections for more details.

The PTAT voltage is computed as follows:

Equations 2:

$$V_{PTAT} = (DIAG1/16384d) \times V_{REF}$$

or

$$V_{PTAT} = (DIAG2/16384d) \times V_{REF}$$

Where $V_{REF} = 2.3077V$. The measured voltage can be converted into °C as follows:

Equation 3:

$$T_{DIE} \text{ (in } ^\circ\text{C)} = (V_{PTAT}/A_{V_PTAT}) + T_{OS_PTAT} - 273^\circ\text{C}$$

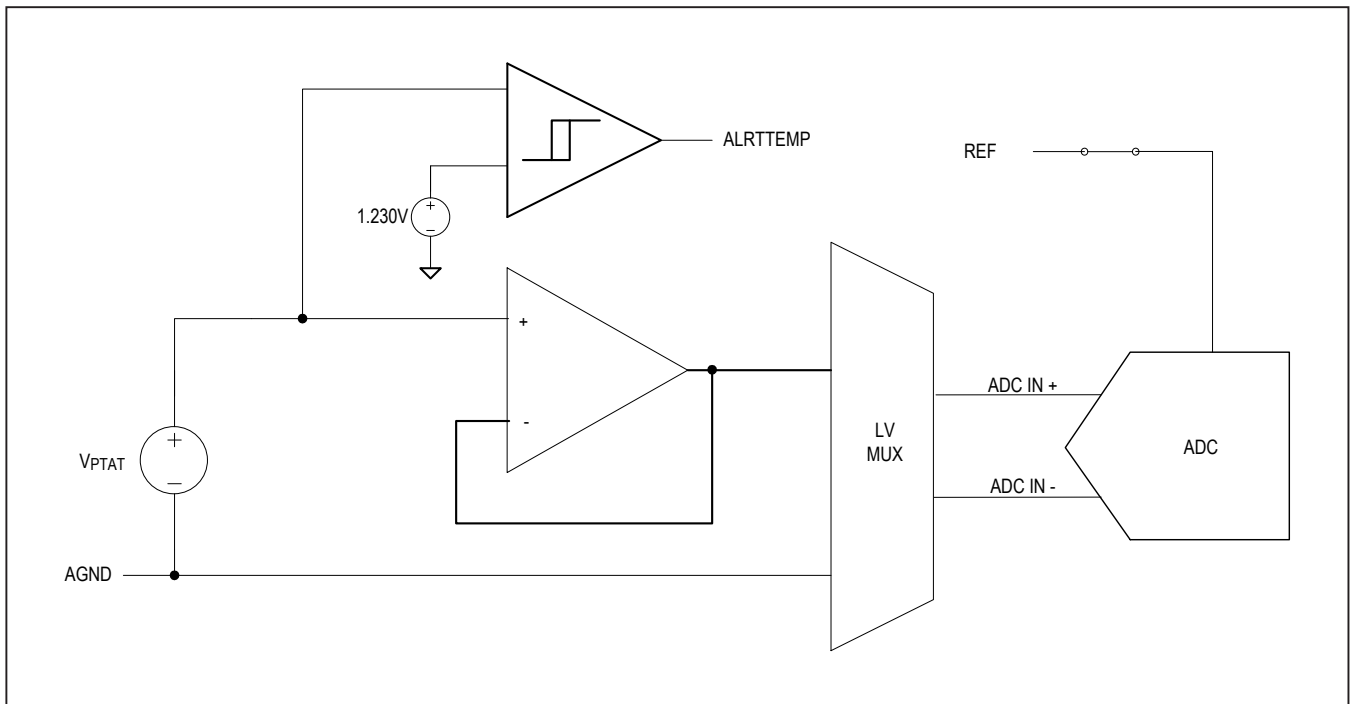

Figure 74. Die-Temperature Measurement

See the [Electrical Characteristics](#) table for A_{V_PTAT} and T_{OS_PTAT} values.

Die-Temperature Alert

The die temperature is continuously monitored in 1ms intervals to detect if $T_{DIE} > T_{ALRTTEMP}$. When die temperature is greater, the ALRTTEMP bit in the FMEA2 register is asserted. The only exception is ALRTTEMP monitoring is temporarily disabled when the die-temperature measurement is requested by configuring DIAGSEL1[3:0] or DIAGSEL2[3:0]=1h. The signal path for die-temperature alert and measurement is shown in [Figure 74](#).

If ALRTTEMP is set, the host should consider the possibility that the acquisition does not meet the expected accuracy specification, or the die-temperature measurement itself may be inaccurate due to insufficient settling time (< two cell measurements enabled).

V_{AA} Diagnostic Measurement

The V_{AA} diagnostic measurement (DIAGSEL1 or DIAGSEL2=0b0010) verifies that V_{AA} is within specification. This diagnostic measures V_{REF} while using V_{AA} as the ADC reference. Signal path for the V_{AA} diagnostics is shown in [Figure 75](#)

The voltage into the ADC is computed from the result in the DIAG1REG (or DIAG2REG) register, as follows.

Equation 4:

$$(6/13) \times V_{REF} = (DIAG1REG[15:2]/16384) \times V_{AA}$$

V_{AA} can be calculated as follows.

Equation 5:

$$V_{AA} = (6/13) \times V_{REF} \times 16384/DIAG[15:2]$$

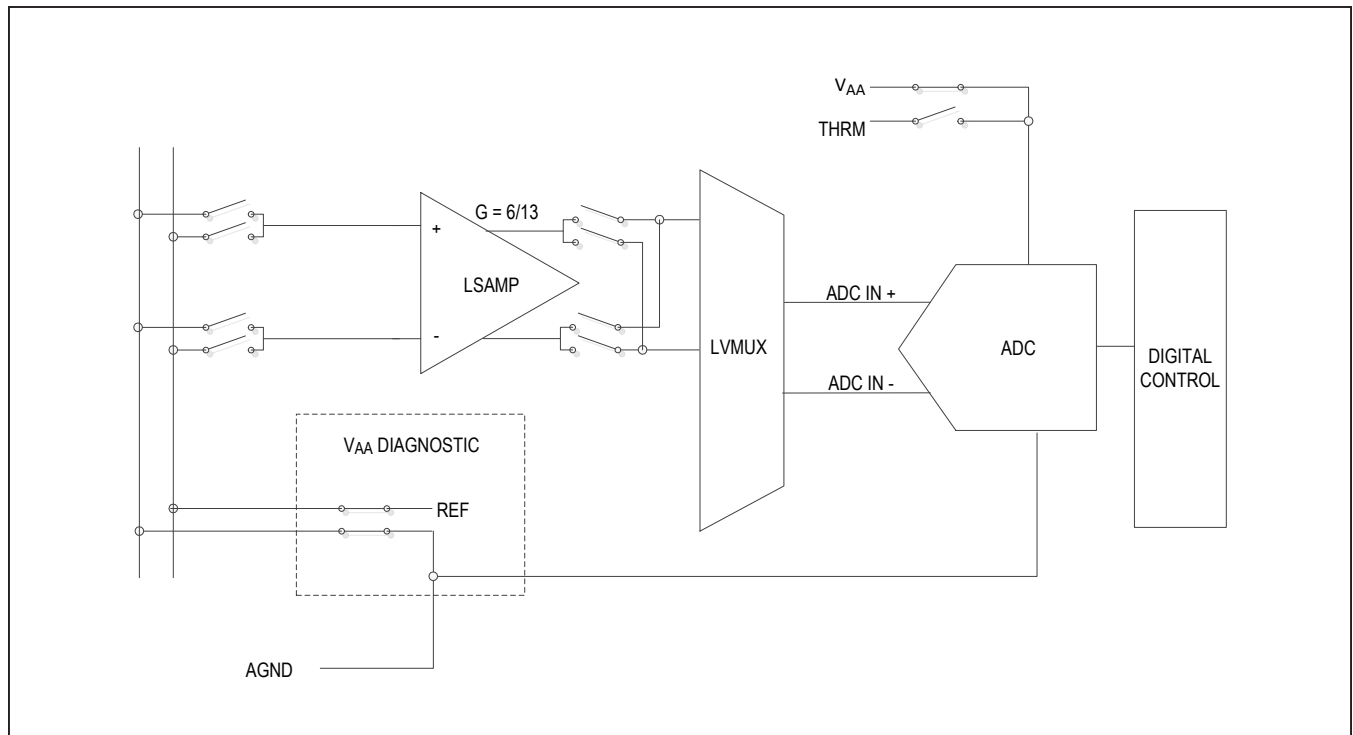

Figure 75. V_{AA} Diagnostic

where $V_{REF} = 2.3077V$

The result for V_{AA} should fall within the range provided in the *Electrical Characteristics* table for V_{AA} .

For ADCCALEN=1, the 14-bit ADC measurement that passes the diagnostic ranges from 0x1576 to 0x13E4, based on the *Electrical Characteristics* specs.

For ADCCALEN=0, the 14-bit ADC measurement that passes the diagnostic ranges from 0x1592 to 0x13CA based on the *Electrical Characteristics* specs.

Note: With any sampled measurement, the signal-chain noise performance must be considered within the measurement result. For consistent measurement performance, is recommended to average V_{AA} within multiple system-measurement cycles to mitigate the variation seen by noise.

ALTREF Diagnostic Measurement

The ALTREF diagnostic measurement (DIAGSEL1 or DIAGSEL2=0b0011) checks the primary voltage reference of the ADC by measuring the alternate reference voltage (V_{ALTREF}) while using V_{REF} as the ADC reference. The result is available in the DIAG1REG (or DIAG2REG) register. The ALTREF voltage is computed from the result in the DIAG register as follows.

Equation 6:

$$V_{ALTREF} \times (6/13) = (DIAG[15:2]/16384) \times V_{REF}$$

Because $V_{REF}/(6/13)$ should nominally equal 5V, V_{ALTREF} can be determined as follows.

Equation 7:

$$V_{ALTREF} = (DIAG[15:2]/16384) \times 5V$$

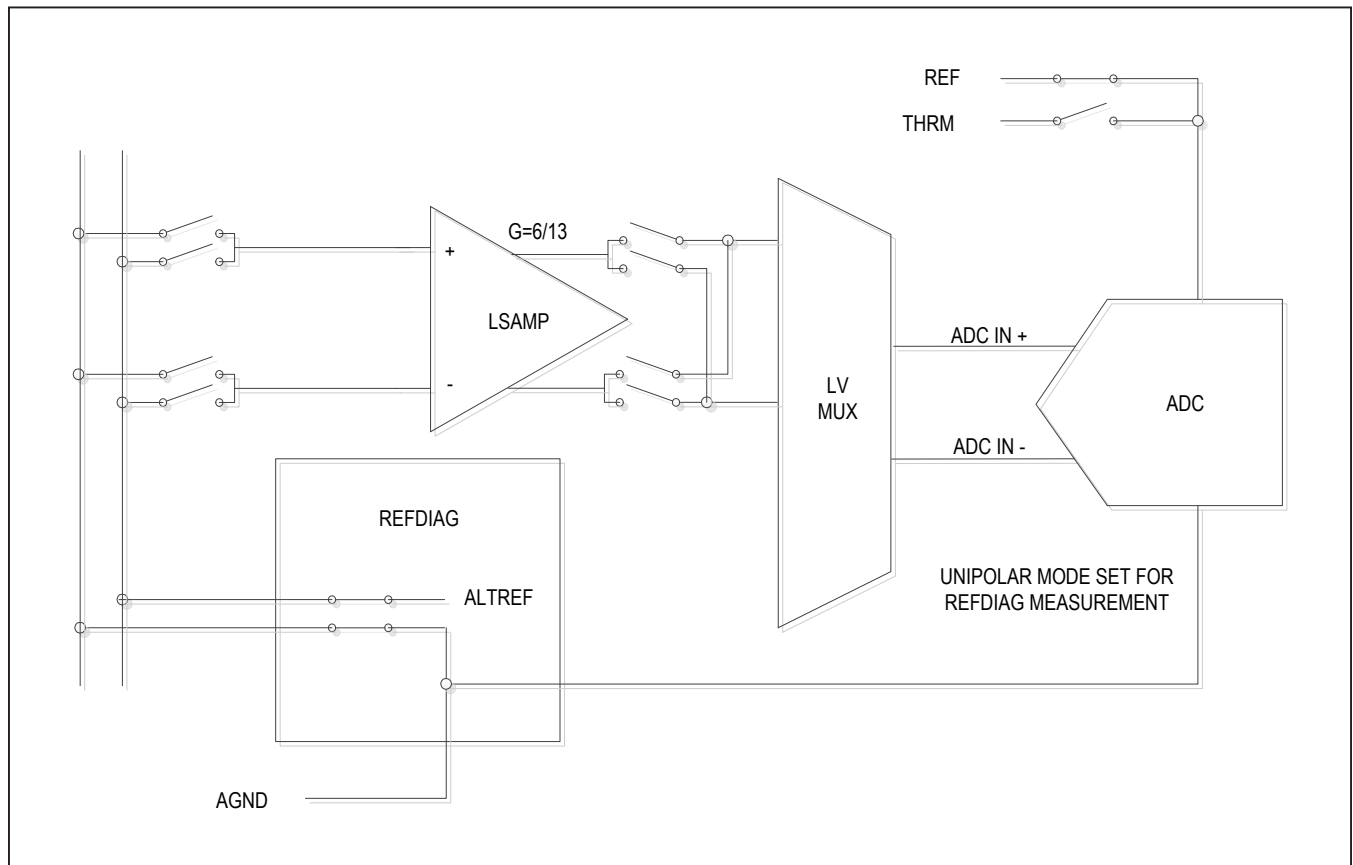

Figure 76. ALTREF Diagnostic

During ALTREF diagnostic measurements, the ADC is automatically set to unipolar mode. The signal path for ALTREF diagnostic is shown in [Figure 76](#).

Since $1.23V < V_{ALTREF} < 1.254V$ and $V_{ALTREF} = 1.242V$ (nom), the expected range for `DIAG[15:2]` is shown below.

For `ADCCALEN=1`, the 14-bit ADC measurement that passes the diagnostic ranges from `0x0FFA` to `0xFD5`.

For `ADCCALEN=0`, the 14-bit ADC measurement that passes the diagnostic ranges from `0x1024` to `0xFAE`.

Note: With any sampled measurement, the signal-chain noise performance must be considered within the measurement result. For consistent measurement performance, it is recommended to average V_{ALTREF} within multiple system-measurement cycles to mitigate the variation seen by noise.

Comparator Signal-Path Diagnostic Measurement

The comparator signal conditioning path can be measured by the ADC, which allows for the following capabilities:

- Comparator-functionality verification against specification

- Comparator-thresholds calibration
- Increased comparator performance for improved specification beyond that described in the [Electrical Characteristics](#) specs

The functionality of the comparator signal-conditioning path (shown in [Figure 77](#)) can be measured using `DIAGSEL1=0b0100` or `DIAGSEL2=0b0100` in the `DIAGCFG` register. This configuration applies an input of $V_{REF} = 2.3077V$ to `LSAMP2`, while the DAC is programmed to `0x1D8` (DAC reference of $2.3077V$). The `LSAMP2` path is gained up by 6 and compared against the DAC output gained by a factor of 13. The output of the comparator preamp is routed to the ADC input where it is effectively measured. The result of the ADC measurement will be presented in corresponding `DIAG1REG[15:2]` or `DIAG2REG[15:2]` registers.

Note: It is recommended to run the comparator signal-path diagnostic with an `OVSAMPL=16`.

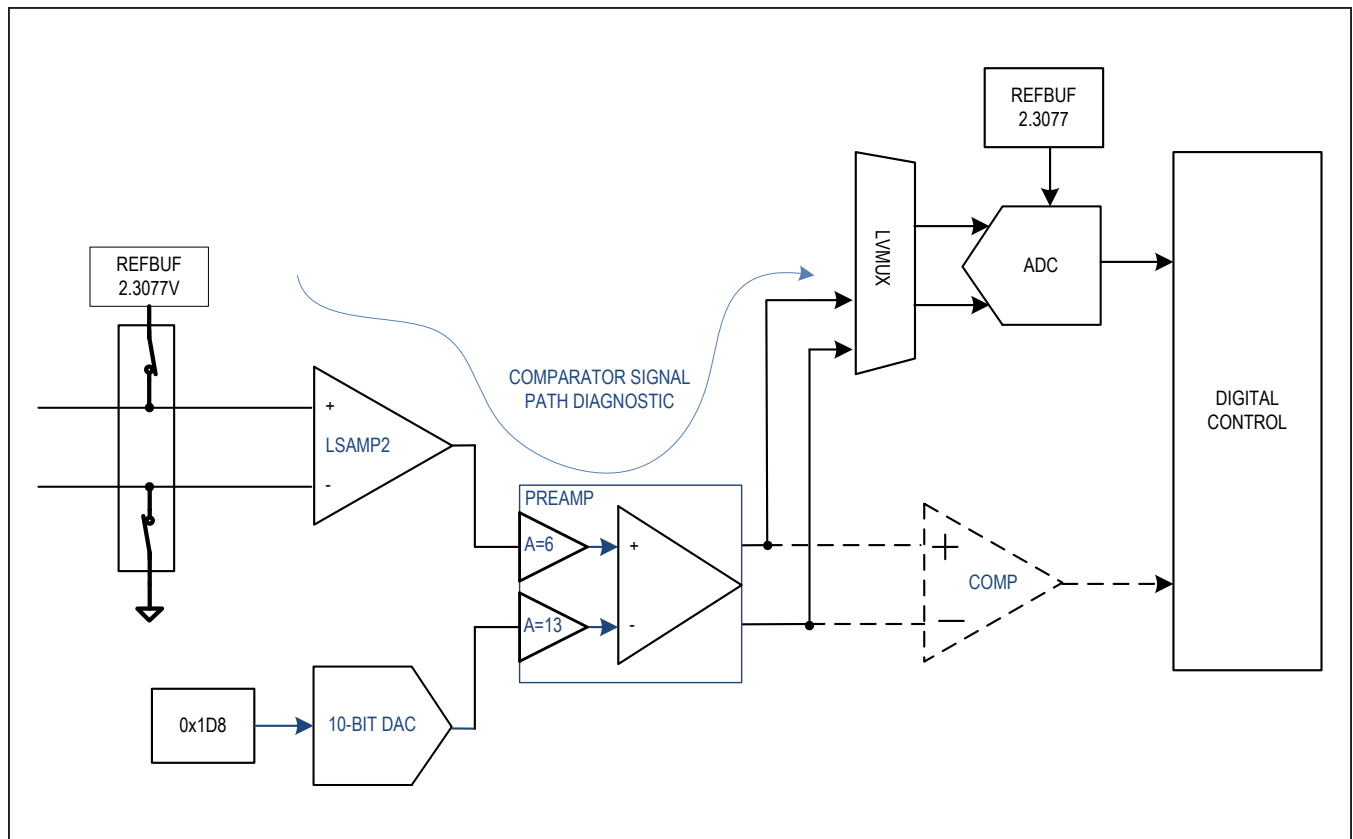

Figure 77. Comparator Signal Path to ADC

Comparator functionality is verified by comparing the DIAG register outputs against the ranges shown in table shown below:

In addition to verifying functionality against the specification, the DIAGn register output can be used to calculate the error of the comparator-cell signal path, as shown in the following equation.

Equation 8:

$$\epsilon_{\text{COMP_CELLPATH}} = \frac{1}{13} \times \left(\frac{\text{DIAG1REG}[15:2] - 0d8224}{0d16384} \right) \times 5V$$

The error can then be used by the user to manually adjust the comparator OV and UV thresholds (COMPOVTH, COMPUVTH, COMPACCOVTHREG, COMPACCUVTHREG) to ensure that the thresholds are applied to the true comparator performance.

Equations 9:

$$\text{COMPOVTH}_{\text{Adjusted}} = \text{COMPOVTH}_{\text{Desired}} + \text{Round}(\epsilon_{\text{COMP_CELLPATH}} \times 1023/5)$$

$$\text{COMPUVTH}_{\text{Adjusted}} = \text{COMPUVTH}_{\text{Desired}} + \text{Round}(\epsilon_{\text{COMP_CELLPATH}} \times 1023/5)$$

Note: the above threshold corrections cannot be applied to the AUX measurements since the correction includes LSAMP2 errors.

The computed error value also allows the user to specify improvement in the comparator accuracy beyond what that described in the [Electrical Characteristics](#) specs.

Equation 10:

$$V_{\text{OS_COMP_EFFECTIVE}} = \sqrt{\epsilon_{\text{COMP_CELLPATH}}^2 + 0.004^2}$$

For example, if the DIAG1 register output reads 0x1FEC (0d7996) then the following adjustments can be applied.

Equations 11:

$$\epsilon_{\text{COMP_CELLPATH}} = \frac{1}{13} \times \left(\frac{0d7996 - 0d8224}{0d16384} \right) \times 5V = -5.35mV$$

$$\text{COMPOVTH}_{\text{Adjusted}} = \text{COMPOVTH}_{\text{Desired}} + \text{Round}(-5.35mV \times 1023/5)$$

$$\text{COMPOVTH}_{\text{Adjusted}} = \text{COMPOVTH}_{\text{Desired}} - 1$$

$$\text{COMPOVTH}_{\text{Adjusted}} = \text{COMPOVTH}_{\text{Desired}} + \text{Round}(-5.35mV \times 1023/5)$$

$$\text{COMPOVTH}_{\text{Adjusted}} = \text{COMPOVTH}_{\text{Desired}} - 1$$

Comparator-Accuracy Diagnostic

The COMPACCEN bit in the ACQCFG register is used to test the accuracy of the comparator and is evaluated at the end of a measurement sequence for configurations that use the comparator (SCANCFG=001b or 010b in the SCANCTRL register) during scans. When COMPACCEN=1, VREF = 2.3077V is configured as the

Table 69. Comparator Signal-Path Diagnostic Verification Ranges

	UPPER DIAGNOSTIC RANGE	LOWER DIAGNOSTIC RANGE
ADCALEN=1	0x2480	0x1BC0
ADCALEN=0	0x24A0	0x1BA0

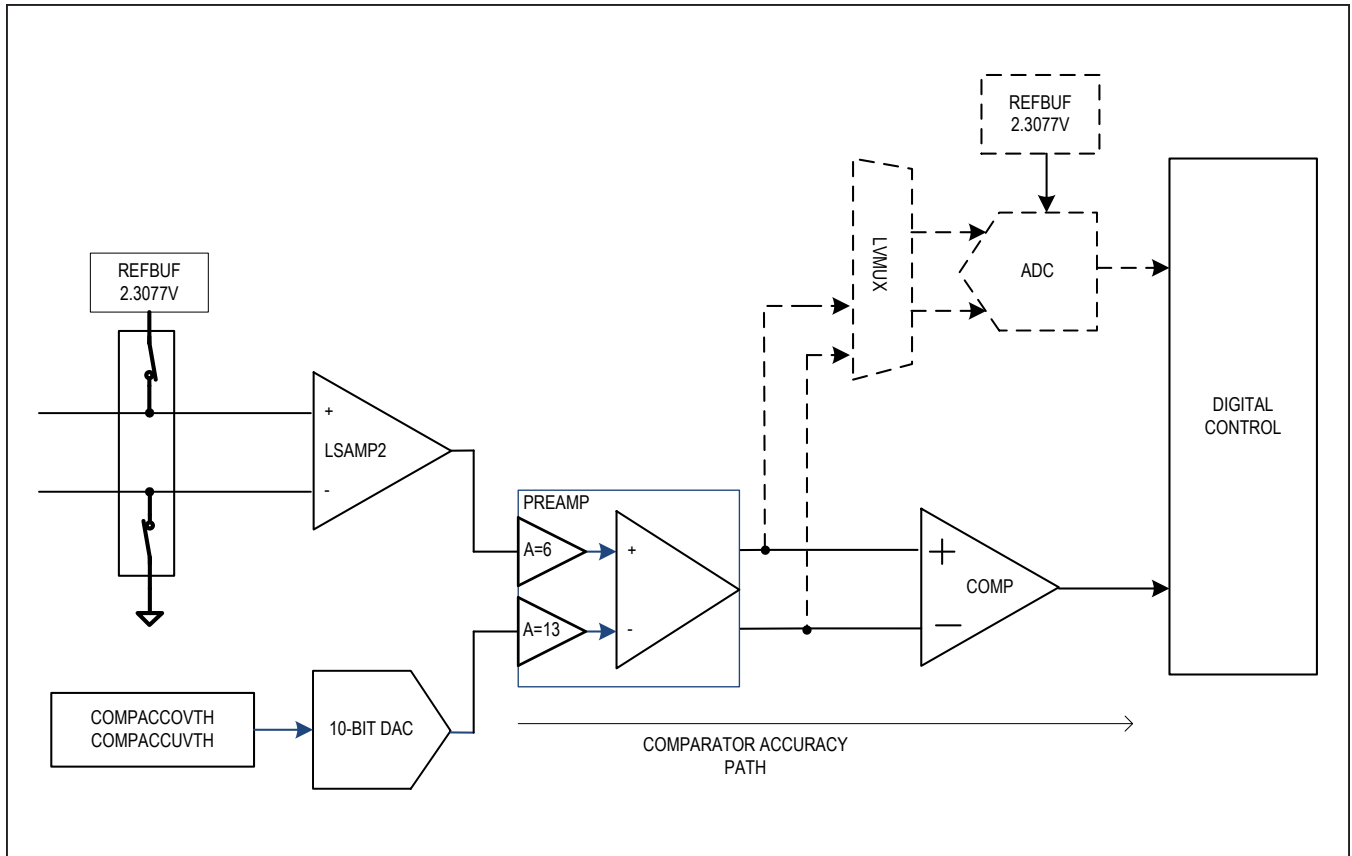

Figure 78. Comparator Accuracy Diagnostic Path

input to the LSAMP2; the 10-bit DAC uses values from the COMPACCOVTH and COMPACCUVTH registers.

An overvoltage alert is issued by setting the ALRTCOMPACCOV bit in the FMEA2 register if the threshold value in COMPACCOVTH is violated.

If COMPACCOVTH=1D8h, the comparator may set the ALRTCOMPACCOV bit (expected to be set for the ideal case).

An undervoltage alert is issued by setting the ALRTCOMPACCUV bit in the FMEA2 register if the threshold value in COMPACCUVTH is violated.

If COMPACCUVTH=D8h, the comparator may not set the ALRTCOMPACCUV bit (not expected to be set for the ideal case).

Comparator Accuracy diagnostic-signal path is shown in [Figure 78](#).

To eliminate a false alert, the user should adjust COMPACCOVTH and COMPACCUVTH by ± 5 DAC codes.

See the *Comparator Signal Path Diagnostic Measurement* section for details on setting these thresholds.

Comparator Accuracy diagnostics procedure, requested by setting COMPACCEN=1, is run only once at the end of

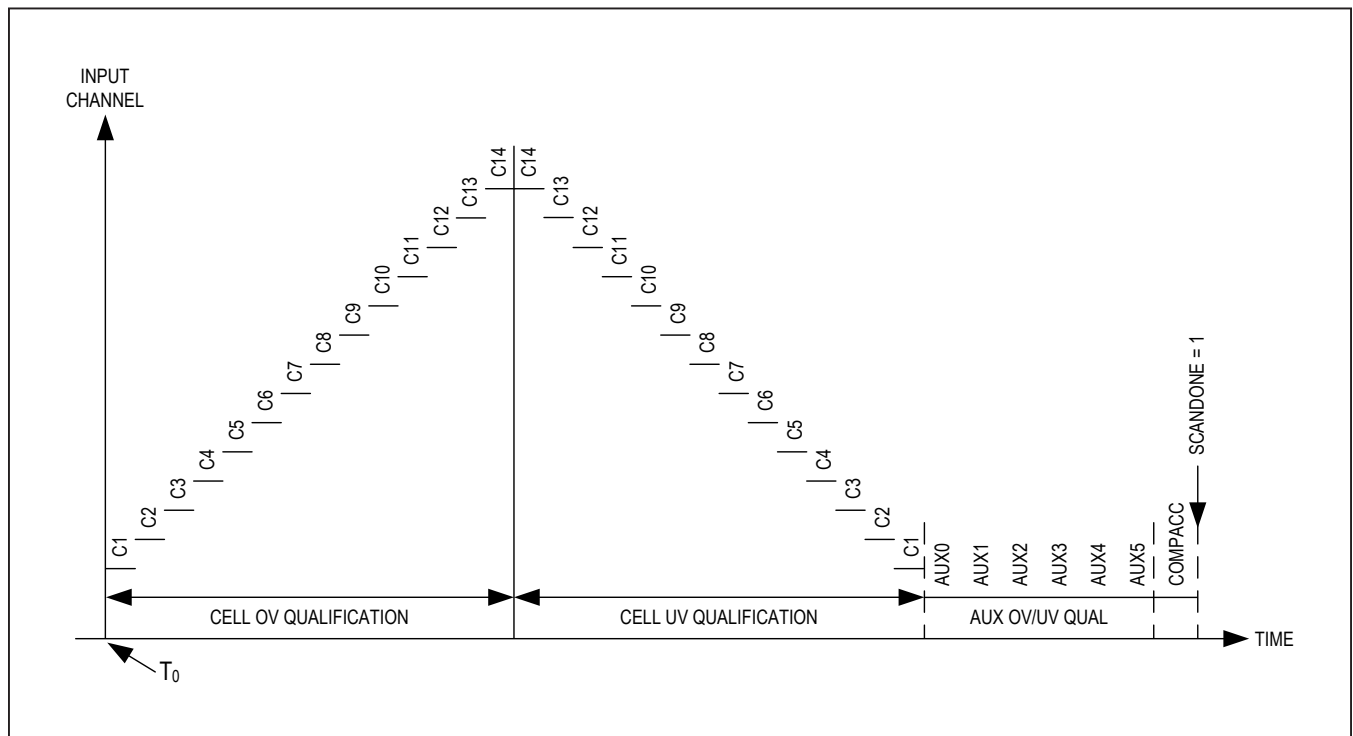

Figure 79. Comparator Accuracy End of Scan Measurement

the last oversample of the SCAN measurement request, as shown in [Figure 79](#).

Cell Gain-Calibration-Diagnostic Measurement

The cell gain-calibration diagnostic verifies that on-demand calibration is functioning correctly and the ADC and LSAMP1 are operating within the specification described by the [Electrical Characteristics](#) table. This diagnostic is run by setting the DIAGSEL1=0b0101 or DIAGSEL2=0b0101 in the DIAGCFG register in accordance with the SCANMODE setting. Thus, if SCANMODE is configured for Pyramid mode operation when this diagnostic is run, the sampling will occur as two conversion phases and effectively chop the offset. Similarly, if SCANMODE is configured for Ramp mode operation when this diagnostic is run, only a single conversion phase is implemented. This diagnostic must be run for

each of the SCANMODE configurations utilized by the application to validate calibration.

The diagnostic is performed by multiplexing V_{REF} into the LSAMP1 inputs, as shown in [Figure 80](#). The OVSAMPL bitfield used during this diagnostic acquisition must be minimally configured to an oversample of 16, which ensures proper accuracy performance.

The expected result is 6/13 of full-scale (0x1D8A) voltage and can be read from the DIAG1REG[15:2] or DIAG2REG[15:2] registers. To allow 14-bit ADC measurements should extend from 0x1D7D to 0x1D97.

Note: This diagnostic should not be run without enabling calibration.

Offset-Calibration Diagnostic

The offset-calibration diagnostic is run by setting DIAGSEL1=0b0110 or DIAGSEL2=0b0110 in the

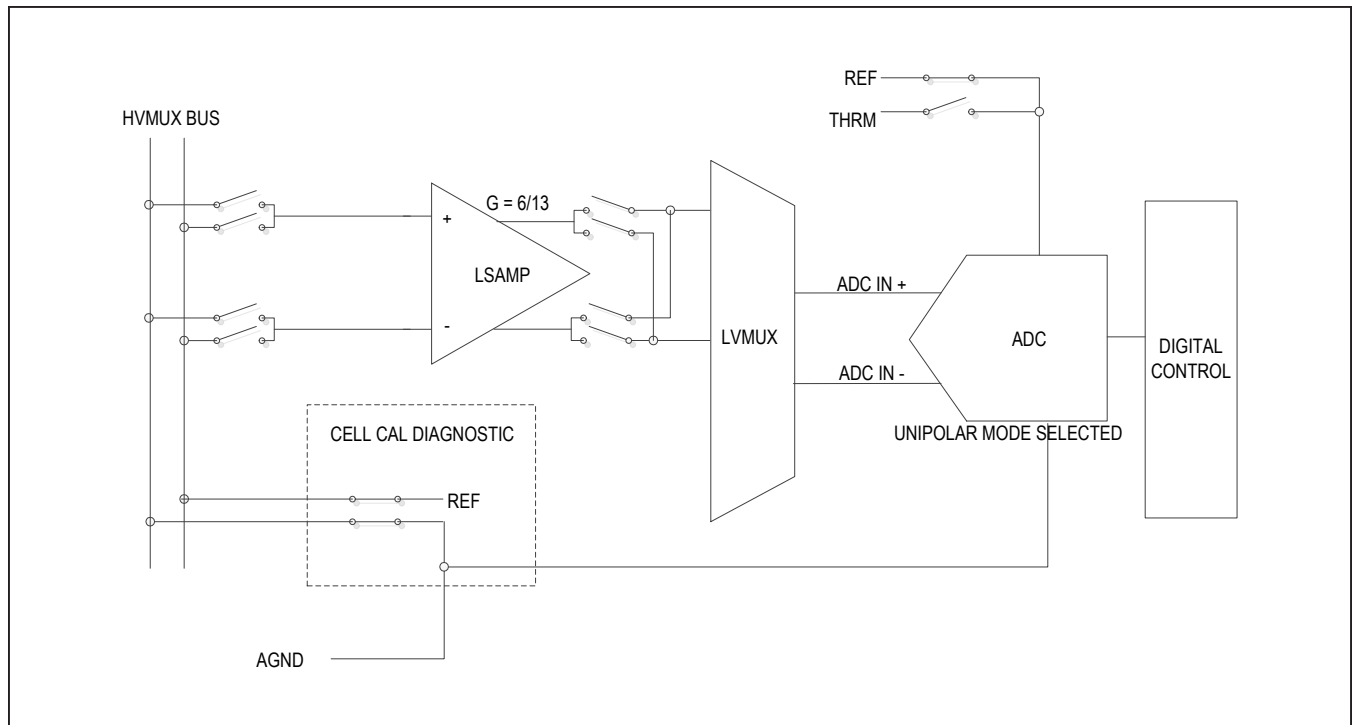

Figure 80. Cell Gain Calibration-Diagnostic Measurement

DIAGCFG register. This diagnostic verifies that on-demand calibration is functioning correctly and operating within the *Electrical Characteristics* table specs.

This diagnostic is configured differently depending on the SCANMODE setting in the SCANCTRL register. When configured in Pyramid mode (SCANMODE=0), the diagnostic is performed by shorting the ADC inputs and performing an acquisition with the ADC polarity overridden in bipolar mode. When configured in Ramp mode (SCANMODE=1), the diagnostic is performed by shorting the LSAMP1 inputs to ground and performing an unchopped acquisition with the ADC polarity overridden in bipolar mode. For both SCANMODE configurations, the OVSAMPL bitfield used

during this diagnostic acquisition must be minimally configured to an oversample of 16 to ensure proper accuracy performance. The expected result is 0V (0x2000) and can be read from the DIAG1REG[15:2] or DIAG2REG[15:2] registers.

For Pyramid mode, the 14-bit ADC measurement bound that passes this diagnostic ranges from 1FF3h to 200dh.

For Ramp mode, the 14-bit ADC measurement bound that passes this diagnostic ranges from 1FEAh to 2011h.

The signal path is shown in [Figure 81](#).

Note: This diagnostic should not be run without enabling calibration.

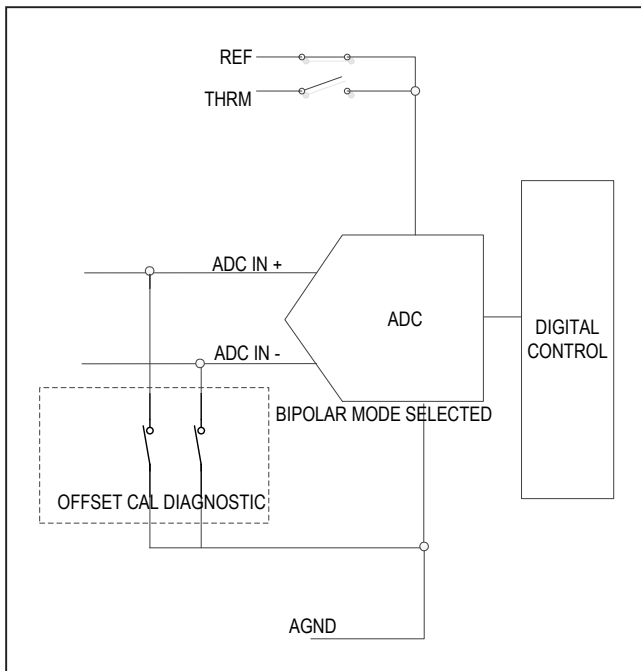

Figure 81. Offset-Calibration Diagnostic

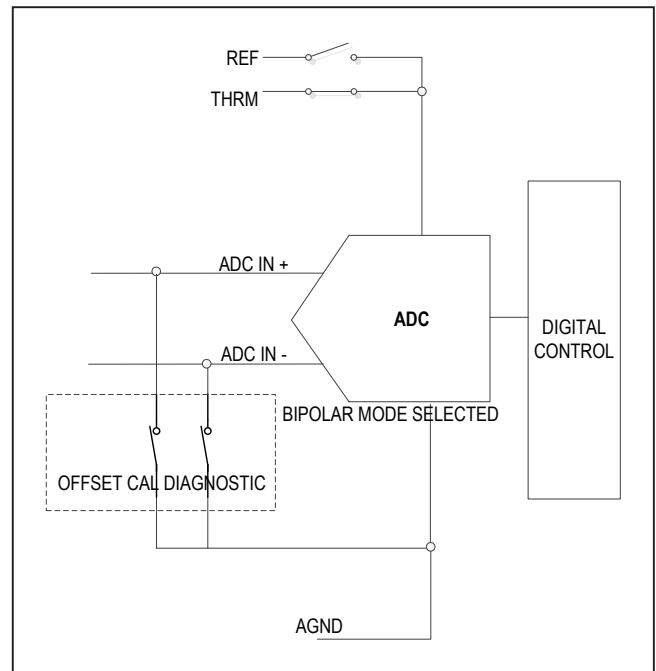

Figure 82. THRM Offset-Calibration Diagnostic

THRM Offset-Calibration Diagnostic

The THRM offset-calibration diagnostic is run by setting the DIAGSEL1=0b1001 or DIAGSEL2=0b1001 in the DIAGCFG register. The diagnostic verifies that on-demand calibration for the THRM case is functioning correctly and the ADC is operating within the specification described in the [Electrical Characteristics](#) table. This is performed by shorting the ADC inputs to ground with ADC reference connected to THRM, and performing an acquisition with a recommendation of minimum 16x oversample (OVSAMPL=0b011) in bipolar mode. If ADCCALEN=1, appropriate calibration coefficients are applied to the diagnostic result. The signal path can be seen in [Figure 82](#).

The expected result is 0V or DIAG1/2[15:2]=2000h (nom). For ADCCALEN=1, the 14-bit ADC measurement bound that passes this diagnostic ranges from 1FF8h to 2003h.

For ADCCALEN=0, the 14-bit ADC measurement bound that passes this diagnostic ranges from 1FB0h to 204Fh.

LSAMP Offset-Diagnostic Measurement

The LSAMP diagnostic measurement (DIAGSEL1 or DIAGSEL2=0b1100) measures the level-shift amplifier offset by shorting the LSAMP inputs during the diagnostic portion of the acquisition. The result is available in the DIAG1REG or DIAG2REG registers after an acquisition. For this measurement, the ADC polarity is automatically set to bipolar mode to allow accurate measurement of voltages near zero. This measurement eliminates the chopping phase to preserve the offset error. If the diagnostic

measurement exceeds the valid range for V_{OS_LSAMP} , as specified in the [Electrical Characteristics](#) table, the chopping function may not be able to cancel out all the offset error, and acquisition accuracy could be degraded accordingly. Signal path for this diagnostic is shown in [Figure 83](#).

The LSAMP offset is computed from the result in the DIAG1 or DIAG2 as follows: LSAMP Offset = $(|DIAGn[15:2] - 2000h|/16384d) \times 5V$.

For ADCCALEN=0, the 14-bit ADC measurement bound that passes this diagnostic ranges from 1D59 to 22A9h.

For ADCCALEN=1, the 14-bit ADC measurement bound that passes this diagnostic ranges from 1D70h to 228Fh. The validity of measurements through LSAMP is further confirmed by the ALTREF and V_{AA} diagnostics, and comparison of the VBLK measurement to the sum of the cell measurements.

Zero-Scale ADC Diagnostic Measurement

Stuck ADC output bits can be verified with a combination of the zero-scale and full-scale diagnostics. The zero-scale ADC diagnostic measurement (DIAGSEL1 or DIAGSEL2=0b1010) verifies that the ADC conversion results in 000h (12-bit) when its input is at $-V_{AA}$ in bipolar mode (for an input $\leq -2.5V$, DIAG1/2[13:0]=0000h). For this measurement, the ADC is automatically set to bipolar mode. Signal path for this diagnostic is shown in [Figure 84](#).

If the user is looking for a quick combination of ADC zero scale and full scale to detect if the ADC is stuck at some value, this can be performed as part of end of scan by

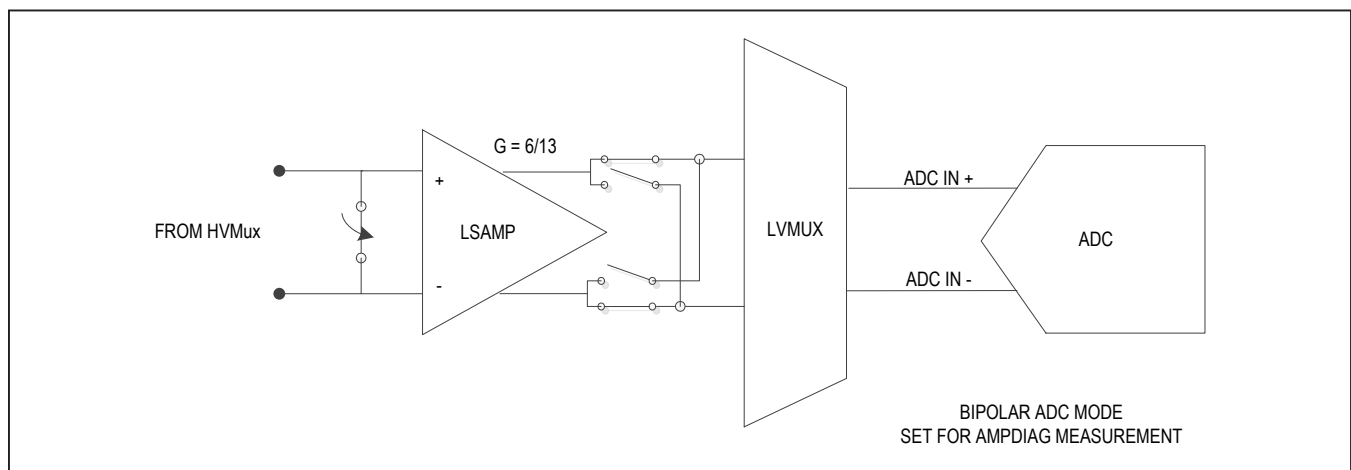

Figure 83. LSAMP Offset Diagnostic

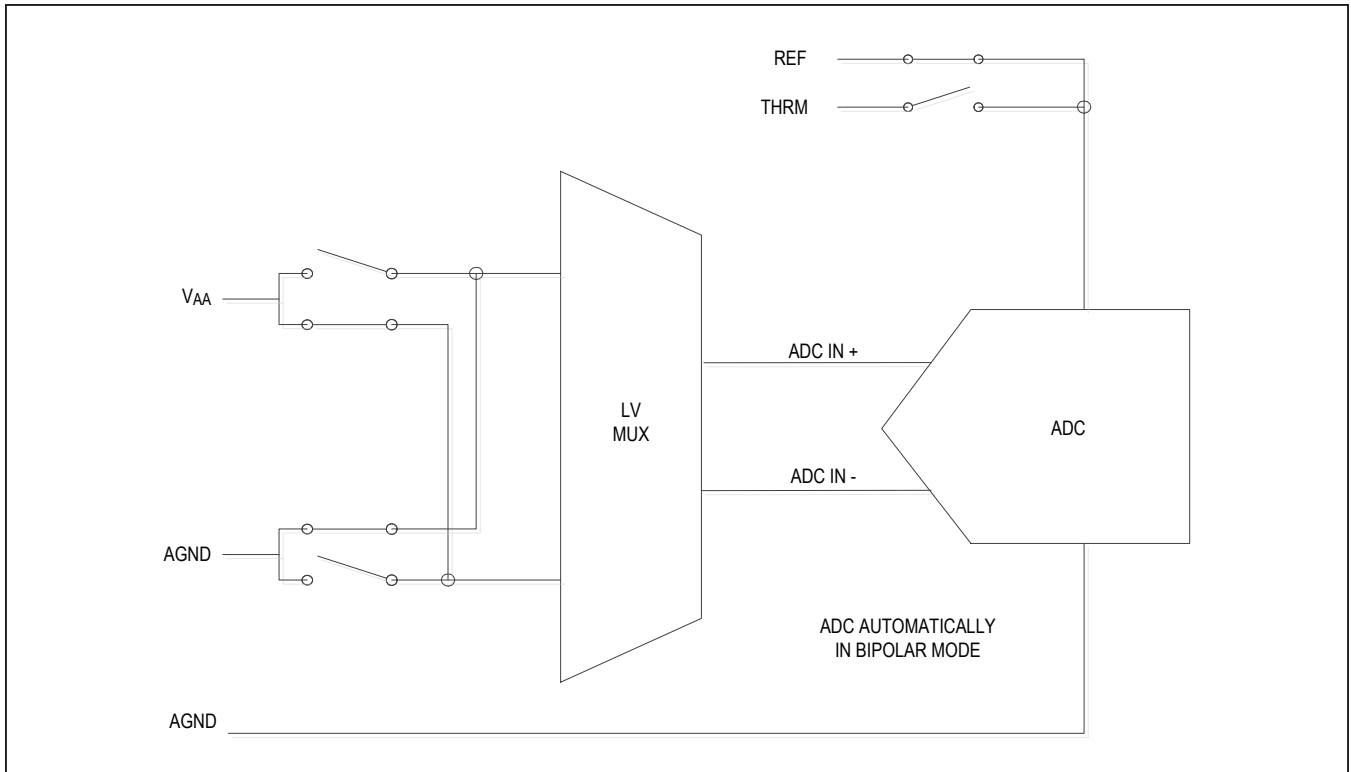

Figure 84. ADC Zero-Scale Diagnostic

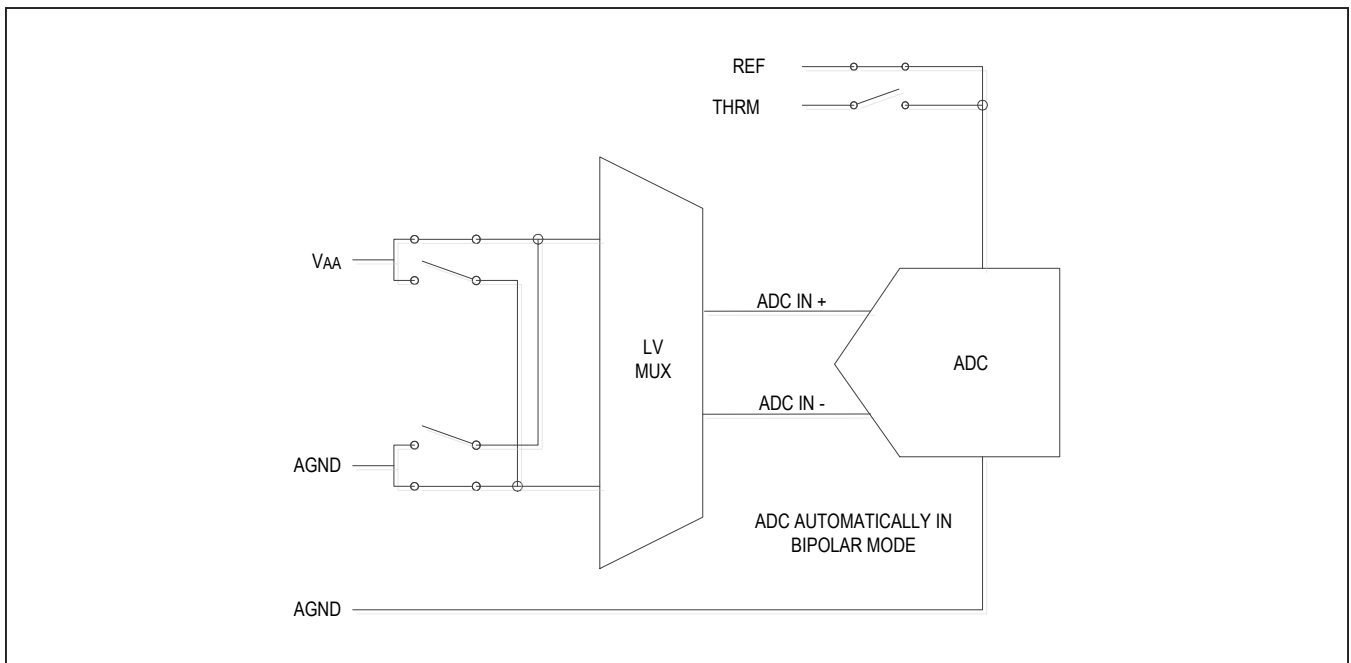

Figure 85. Full-Scale ADC Diagnostic Measurement

configuring ADCZSFZEN=1 and then requesting a SCAN. See the various acquisition timing sections for details on insertion into the scan and timing.

Full-Scale ADC Diagnostic Measurement

Stuck ADC output bits can be verified with a combination of the zero-scale and full-scale diagnostics. The full-scale ADC diagnostic measurement (DIAGSEL1 or DIAGSEL2=0b1011) verifies that the ADC conversion results in FFFh (12-bit) when its input is at V_{AA} in bipolar mode (since for an input $\geq 2.5V$, DIAG1/2[13:0]=3FFCh). For this measurement, the ADC is automatically set to bipolar mode. Signal path for this diagnostic is shown in [Figure 85](#).

If the user is looking for a quick combination of ADC zero scale and full scale to detect if the ADC is stuck at some value, this can be performed as part of end of scan by configuring ADCZSFZEN=1 and requesting a SCAN. See the various acquisition timing sections for details on insertion into the scan and timing.

DAC 1/4 Scale Diagnostic

The DAC 1/4 scale diagnostic can be requested by setting DIAGSEL1 or DIAGSEL2=0x1000. This configures the internal DAC used to set the comparator thresholds to 1/4 of full scale (V_{REF}) or 0x100. The DAC voltage is mux'ed to the ADC and then compared against the bounds shown in [Figure 86](#).

The nominal DAC and ADC voltages are:

$$V_{DAC} = 256/1023 \times 2.3077 = 0.5775V$$

$$V_{ADC} = 0.5775/2.3077 \times 16384 = 4100 = 0x1004$$

For ADCCALEN=1, the 14-bit ADC measurement bounds for passing this diagnostic range from 0x0FD0 to 0x1040.

For ADCCALEN=0, the 14-bit ADC measurement bounds for passing this diagnostic range from 0x0FA0 to 0x1060.

This can be used in conjunction with the DAC 3/4 scale diagnostic to ensure there are no stuck bits that may cause errors with the comparator threshold settings.

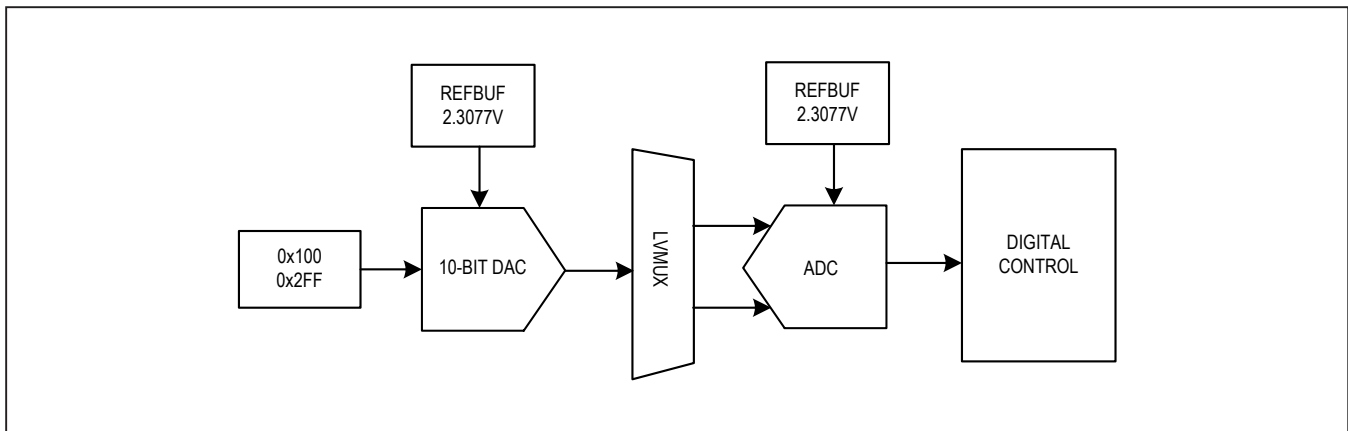

Figure 86. DAC 1/4 and 3/4 Diagnostic

DAC 3/4 Scale Diagnostic

The DAC 3/4 scale diagnostic can be requested by setting DIAGSEL1 or DIAGSEL2=0x0111. This configures the internal DAC used to set the comparator thresholds to 3/4 of full scale (V_{REF}) or 2FFh. The DAC voltage is multiplexed to the ADC and then compared against the bounds shown below.

The nominal DAC and ADC voltages are:

$$V_{DAC} = 767/1023 * 2.3077 = 1.73V$$

$$V_{ADC} = 1.73/2.3077 * 16384 = 2FFAh$$

For ADCCALEN=1, the 14-bit ADC measurement bounds for passing this diagnostic range from 2F80h to 3070h.

For ADCCALEN=0, the 14-bit ADC measurement bounds for passing this diagnostic range from 2F70h to 3080h.

This be used in conjunction with the DAC 1/4 scale diagnostic to ensure there are no stuck bits that may cause errors with the comparator-threshold settings.

BALSW Diagnostics

Four balancing switch diagnostic modes are available to facilitate the following diagnostics:

- Balancing switch shorted (SCANCFG[2:0]=0b100)
- Balancing switch open (SCANCFG[2:0]=0b101)
- Odd sense wire open (SCANCFG[2:0]=0b110)

- Even sense wire open (SCANCFG[2:0]=0b111)

Enabling any of these modes automatically configures several acquisition settings (e.g., enables the ALTMUX measurement path). The host must initiate the acquisition but the diagnostic mode automatically compares the measurements to the specific thresholds, as configured through BALSHRTTHR, BALLOWTHR, or BALHIGHTHR threshold registers and sets any corresponding alerts in the ALRTBALSW register field. The host presets the thresholds, as determined by the minimum and maximum resistance of the switch (R_{SW}) specified in the [Electrical Characteristics](#) table and the intended cell-balancing current.

At the start of a new scan request, the Balance-Switch Fault-Alert Register (ALRTBALSW[13:0]) is cleared if balancing-switch diagnostic mode is requested (SCANCFG=0b100, 0b101, 0b110, or 0b111). The result from the current balancing-switch diagnostic is written to ALRTBALSW[13:0] at the end of scan (SCANDONE=1). The previous result persists in ALRTBALSW until a new scan is requested, with balancing-switch diagnostic mode enabled.

[Table 70](#) describes which Balance Switch Diagnostic Alert Thresholds contribute to ALRTBALSW in each of the four modes.

Table 70. BALSW Diagnostic

MODE	SCANCFG[2:0]	THRESHOLD	FAULT CONDITION
Balancing Switch Short	0b100	BALSHRTTHR	Data < BALSHRTTHR
Balancing Switch Open	0b101	BALLOWTHR, BALHIGHTHR	Data < BALLOWTHR, or Data > BALHIGHTHR
Cell Sense Open Odds	0b110	BALLOWTHR, BALHIGHTHR	Data < BALLOWTHR, or Data > BALHIGHTHR
Cell Sense Open Evens	0b111	BALLOWTHR, BALHIGHTHR	Data < BALLOWTHR, or Data > BALHIGHTHR

The summary status bitfield ALRTBALSWSUM is updated at the end of scan when a balancing switch diagnostic mode is enabled. ALRTBALSWSUM is a bit-wise logical OR of ALRTBALSWSW[13:0].

ALRTBALSWSW is a bitwise alert status for all the 14 channels/switches, the alert masking depend on the TOPCELL1 and TOPCELL2 settings. The user should pay attention that if TOPCELL1 != TOPCELL2 then none of the alerts are masked. If TOPCELL1 = TOPCELL2 all the alerts above TOPCELL1/2 positions are masked. These conditions apply for all the four BALSWSW diagnostic SCAN requests.

The balancing switch diagnostic summary status ALRTBALSWSUM can be cleared if all enabled

ALRTBALSWSW[13:0] alerts are resolved (by subsequent scan) or by writing to logic zero.

Note: In balancing switch diagnostic mode, the ALRTOV, ALRTUV, and ALRTMSMTCH alerts are not updated because these are only applicable during normal cell measurements.

BALSWSW Short Diagnostic

A short-circuit fault in the balancing path could be a short between SWn and SWn-1 as shown in Figure 87 or that a balancing FET is stuck in the conducting state. In the short circuit state, the voltage between SWn and SWn-1 (switch voltage) is less than the voltage between Cn and Cn-1 (cell voltage).

Table 71. BALSWSW-Short Diagnostics Operation

BALSWSW	V _{SWn}	FAULT INDICATED?	POSSIBLE FAULT CONDITION
Off	> V _{BALSWSWTHR}	No	None
	< V _{BALSWSWTHR}	Yes	Short circuit or leakage current

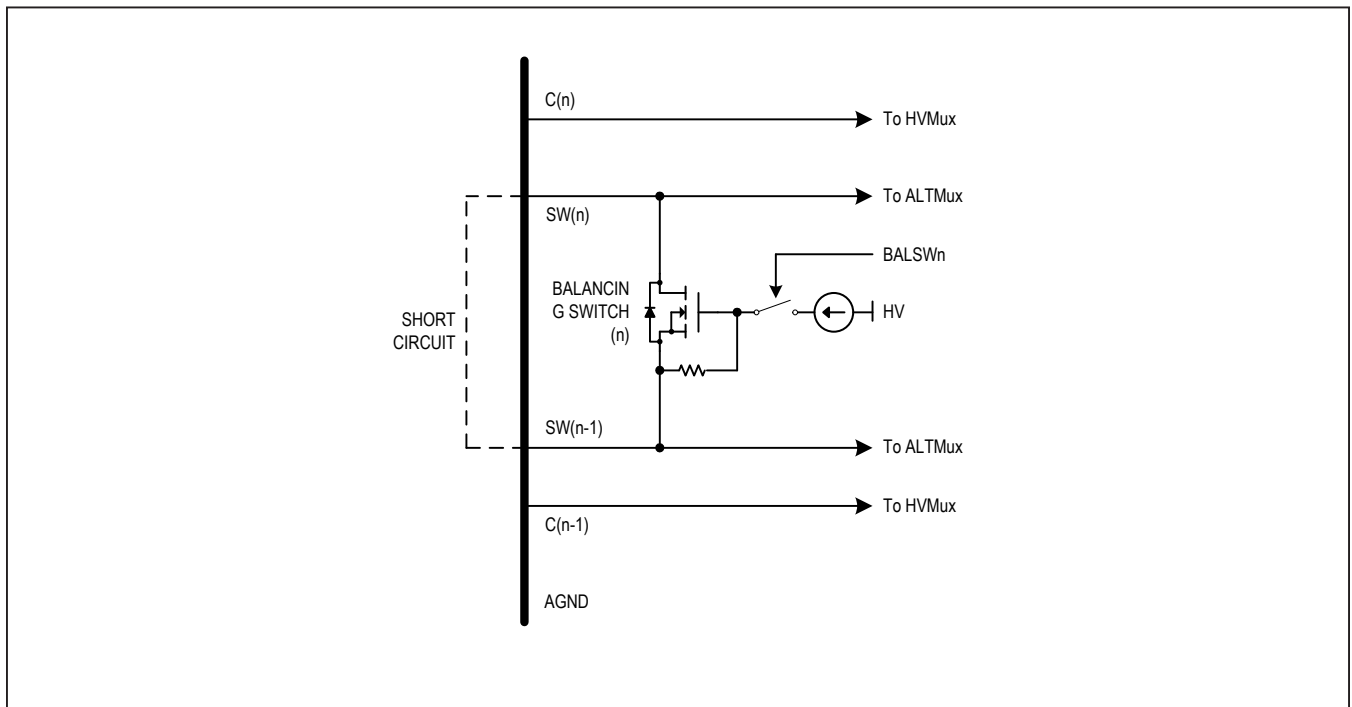

Figure 87. Balancing Switch Short

When enabled, the balancing switch short diagnostic mode (SCANCFG[2:0] = 0b100) functions as follows:

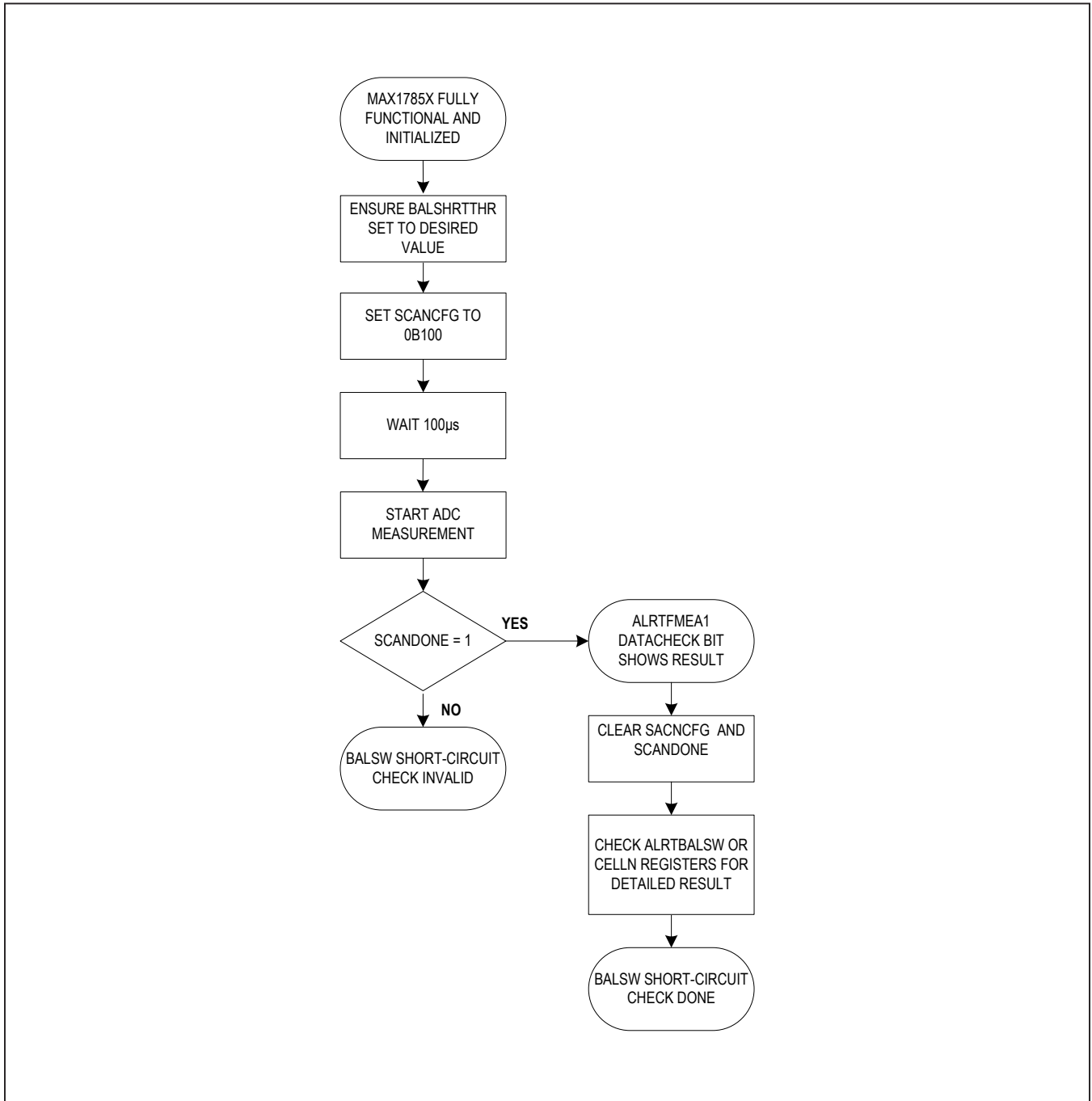

Figure 88. BALSWS Short-Diagnostic Chart

- Disables the balancing switches automatically
- Configures the acquisition using ALTMUX path automatically
- Host initiates the acquisition on selected Unipolar Cells only (\sim POLARITY_n & CELLEN_n)
- Compares the measurement to the threshold value BALSHTTHR automatically (for Unipolar Cells only, i.e. POLARITY_n=0, see [Table 71](#))
- If outside the threshold, sets the corresponding flag in ALRTBALSWSW automatically

For the best sensitivity to leakage current, set the threshold value based on the minimum cell voltage minus a small noise margin (100mV) then update the threshold value periodically or every time a measurement is taken depending on how fast the cell voltages are expected to change.

BALSWSW Short decision is as shown in [Table 71](#).

See [Figure 87](#) for an example of a BALSWSW short.

The BALSWSW Short diagnostic procedural flow chart is shown in [Figure 88](#).

The BALSWSW Short diagnostic automatically overrides the configuration settings during the measurements scan (see [Table 72](#)).

BALSWSW Open Diagnostic

The BALSWSW open diagnostic (SCANCFG[2:0]=0b101) verifies that each enabled balancing switch is conducting (not open) as follows:

- Configures acquisition for bipolar mode (for measuring voltages near zero) automatically
- Configures acquisition for ALTMUX path automatically
- Configures acquisition to measure switch voltages for any switches enabled by BALSWSW_n automatically on all unipolar cell positions (\sim POLARITY_n &

Table 72. BALSWSW Short Diagnostic Auto-Configuration

CONFIGURATION BITS	AUTOMATIC SETTING	PURPOSE
MEASUREEN1[15:14]	0b00	Disable VBLK measurements
MEASUREEN1[13:0]	(\sim POLARITY _n & CELLEN _n)	Enable only selected Unipolar Cell measurements
MEASUREEN2[5:0]	0b000000	Disable AUX _n measurements
BALSWSW[13:0]	0x0000	Disable all balancing switches
DIAGSEL1/2	0x0	Disable all diagnostics
SCANCTRL:ALTMUXSEL	1	Enable ALTMUX measurement path
SCANCTRL:OVSAMPL	0x0	Oversample rates configured to 1

Table 73. BALSWSW Open-Diagnostic Operation

BALSWSW	V _{SWn}	FAULT INDICATED?	POSSIBLE FAULT CONDITION
On	> V _{BALHIGHTHR}	Yes	Switch open circuit, or overcurrent
	> V _{BALLOWTHR}	No	None
	< V _{BALHIGHTHR}		
	< V _{BALLOWTHR}	Yes	Path open circuit, or short circuit

Table 74. BALSWSW Open-Diagnostic Auto-Configuration

CONFIGURATION BITS	AUTOMATIC SETTING	PURPOSE
MEASUREEN1[15:14]	0b00	Disable VBLK measurements
MEASUREEN1[13:0]	BALSWSW _n & \sim POLARITY _n	Measure only active unipolar switch positions
MEASUREEN2[5:0]	0b000000	Disable AUX _n measurements
DIAGSEL1/2	0x0	Disable all diagnostics
SCANCTRL:ALTMUXSEL	1	Enable ALTMUX measurement path
SCANCTRL:OVSAMPL	0x0	Configure oversample rate to 1

BALSWENn). **Note:** it is not necessary for the device to be in an active manual cell-balancing operation, only that BALSWEN will be configured as desired.

- Host initiates acquisition
- Compares each measurement to the threshold value BALLOWTHR and BALHIGHTHR automatically (see [Table 73](#))
- If outside the threshold, sets the corresponding flag in ALRTBALSW automatically

Set the thresholds by taking into account the minimum and maximum R_{SW} of the switch itself, as specified in the [Electrical Characteristics](#) table and the balancing current for the application.

BALSW Open Diagnostics operation decision is as shown in [Table 73](#).

The BALSW Open Diagnostic procedural flow chart is shown in [Figure 89](#).

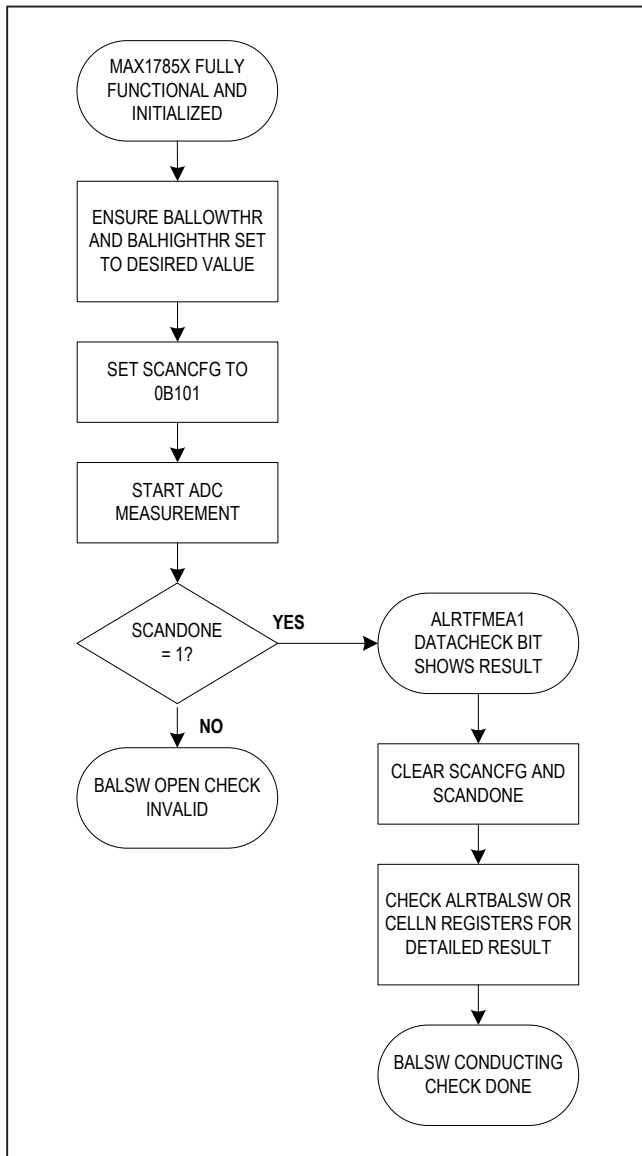

Figure 89. BALSW Open Diagnostic

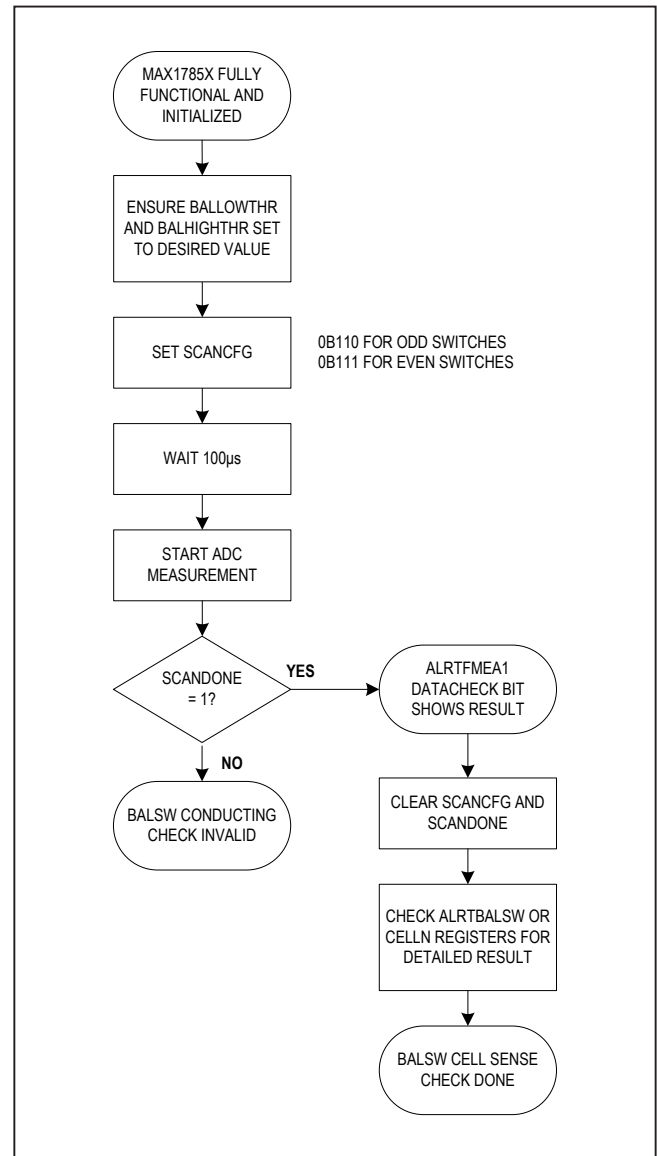

Figure 90. Sense-Wire Open-Diagnostic Flow

The BALS_W Short Diagnostic automatically overrides the configuration settings during the measurements scan (see Table 74).

If enabled, the sense-wire open diagnostic modes detect if a cell sense wire is disconnected as follows:

- Configures acquisition for bipolar mode

Even/Odd Sense-Wire Open Diagnostics

Table 75. Sense-Wire Open-Diagnostic Automatic Configuration Overrides

CONFIGURATION BIT(S)	CONFIGURATION STATE	TASK
BALSWEN[13:0]	1555h (SCANCFG[2:0]=0b110) or 2AAAh (SCANCFG[2:0]=0b111)	Enable odd switches Enable even switches Switch positions with POLARITY _n =1 (bipolar/bus bar) and those above TOPCELL1/2 are masked/disabled.
MEASUREEN1[15:14]	0b00	Disable VBLK measurements
MEASUREEN1[13:0]	(BALSWEN _n & ~POLARITY _n)	BALSWEN[13:0] is set as per automatic overrides shown above. Measure only active switch positions per automatic BALSWEN overrides and unipolar positions.
MEASUREEN2[5:0]	0b000000	Disable AUX _n measurements
DIAGSEL1/2	0x0	Disable all diagnostics
SCANCTRL:ALTMUXSEL	1	Enable ALTMUX measurement path
SCANCTRL:OVSAMPL	0x0	Oversample configured to 1

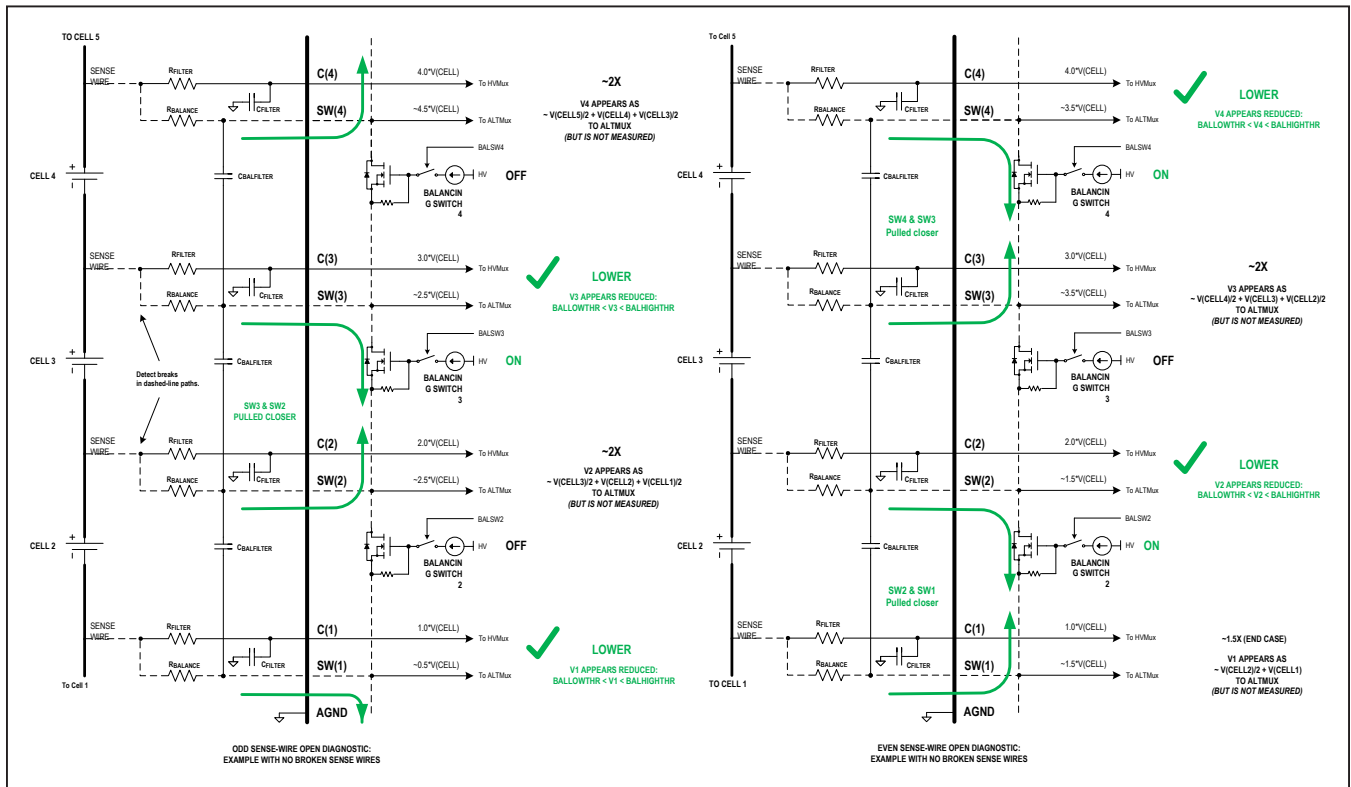

Figure 91. Cell Sense-Wire Open-Diagnostic Operations (Normal Operation)

- (for measuring voltages near zero) automatically
- Closes nonadjacent switches (even or odd) automatically
- Configures acquisition to use ALTMUX path automatically
- Host waits 100µs for settling and then initiates the acquisition
- Compares the result to the BALHIGHTHR and BALLOWTHR registers automatically
- If outside thresholds, sets flags in ALRTBALSW automatically

Examples of normal and faulty operations are shown in [Figure 92](#), [Figure 93](#), [Figure 94](#), and [Figure 95](#) for examples with and without bus bars (identified by POLARITYn=1). By examining the combined reported results from even and odd runs, the location and type of fault can be determined. [Figure 90](#) shows the procedure performed by the MAX17853 during an open sense-wire diagnostic.

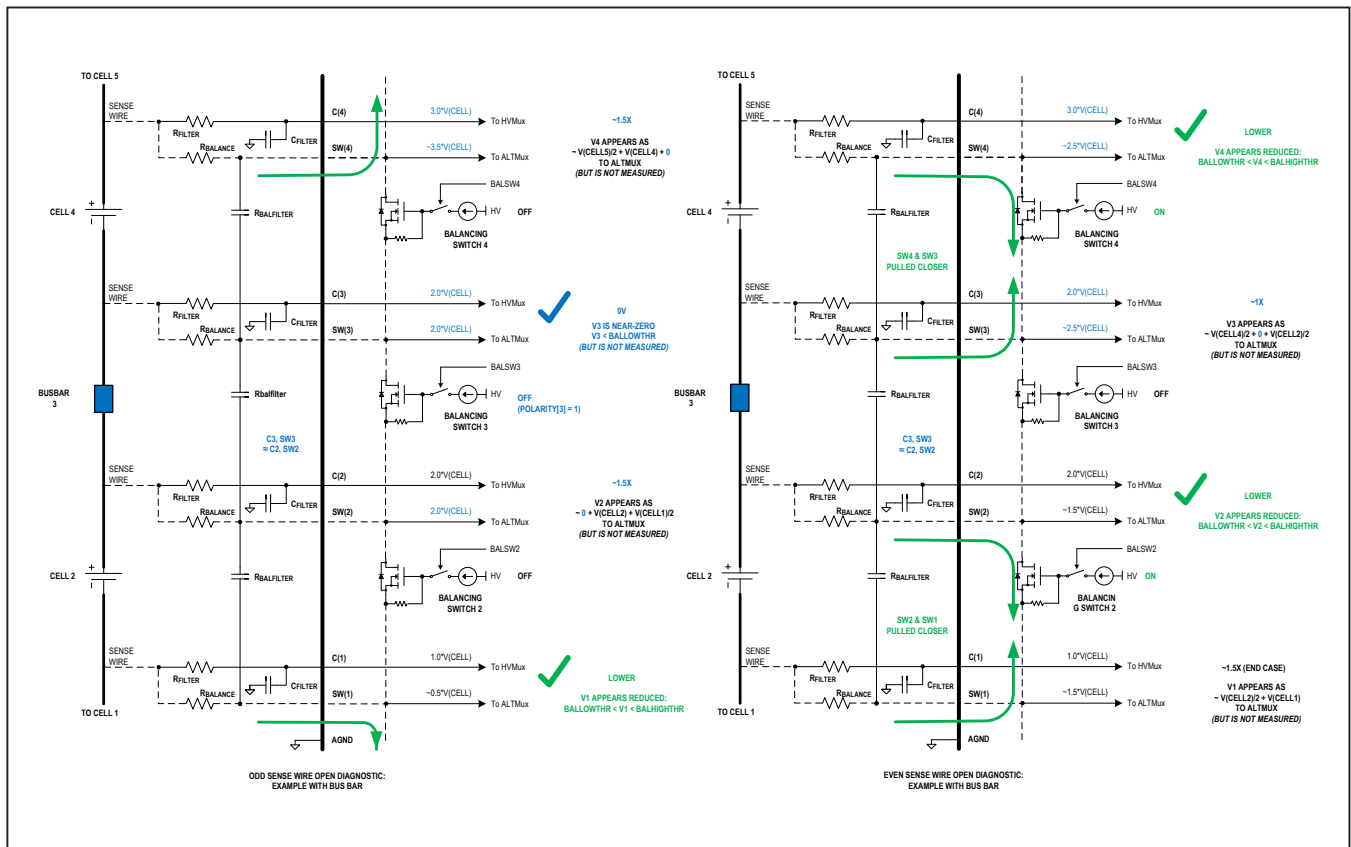

Figure 92. Cell Sense-Wire Open-Diagnostic Operations (Normal Operation, Including Bus Bars)

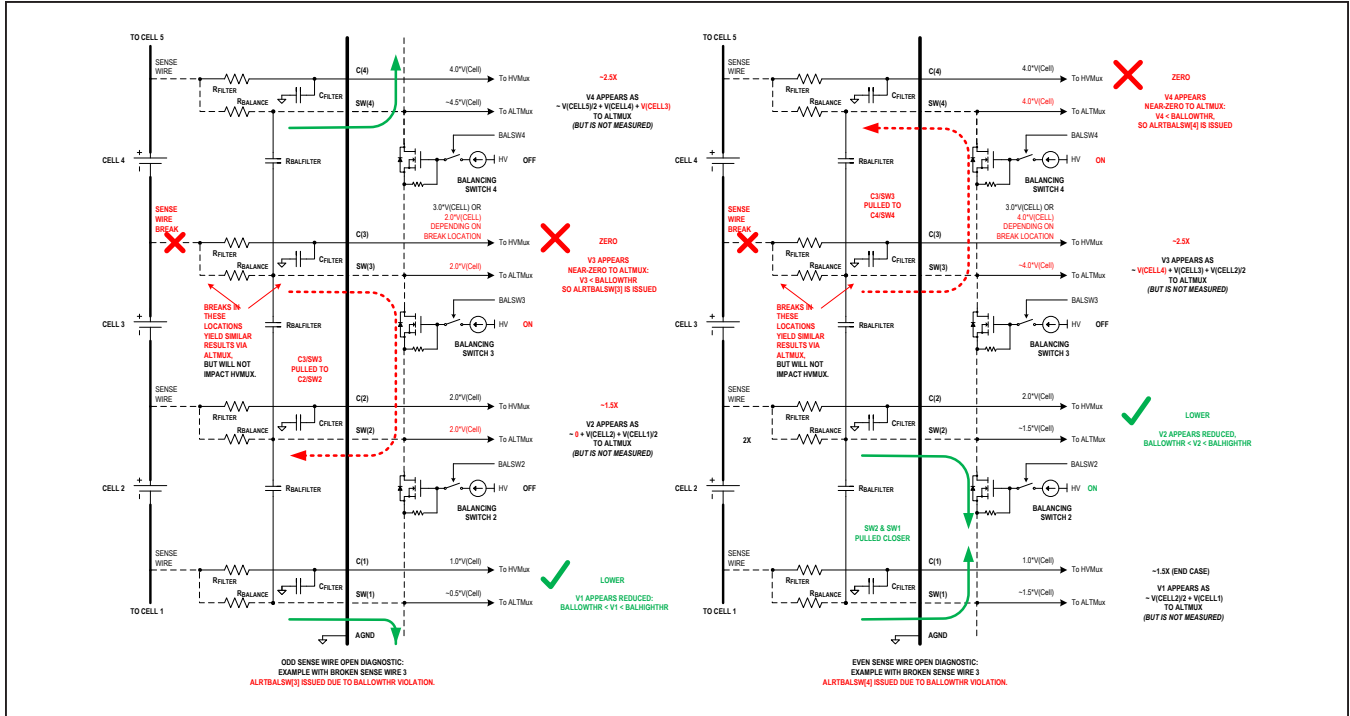

Figure 93. Cell Sense-Wire Open-Diagnostic Operations (Example with Odd Sense-Wire Fault)

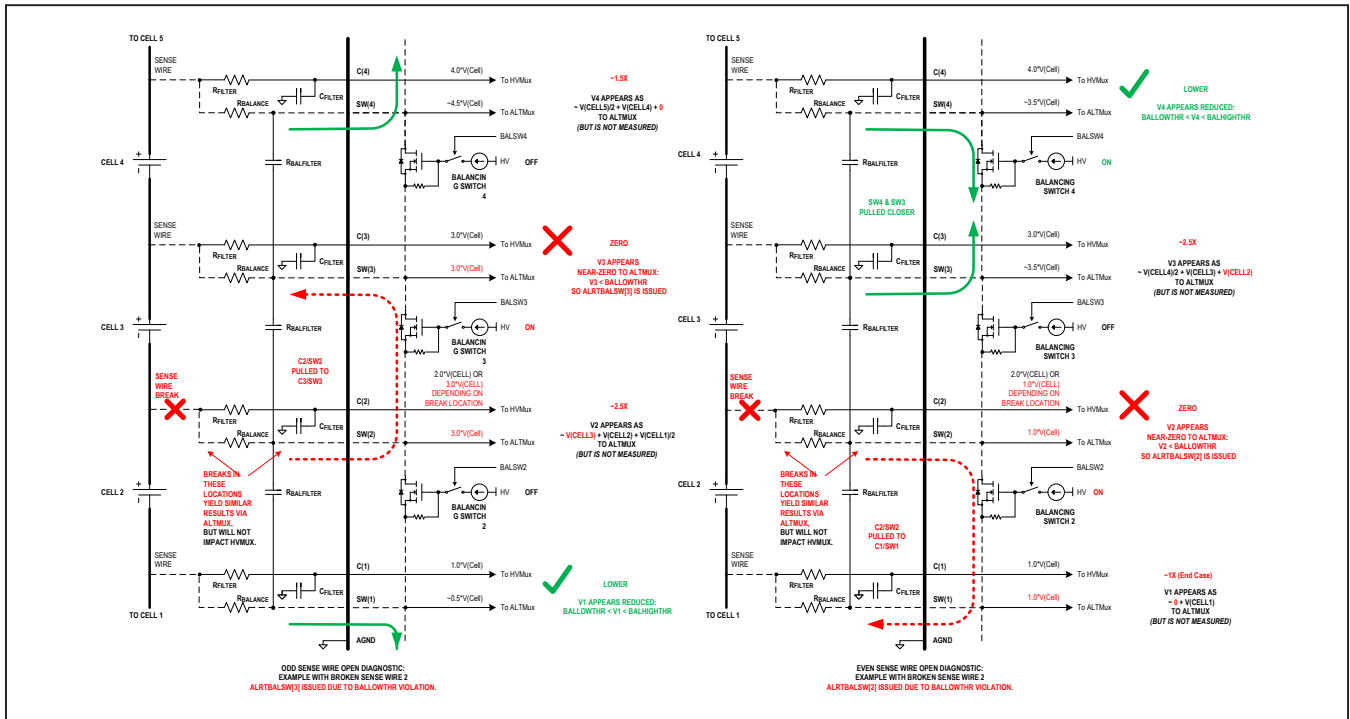

Figure 94. Cell Sense-Wire Open-Diagnostic Operations (Example with Even Sense-Wire Fault)

Table 75 lists the configuration-setting overrides the MAX17853 temporarily enforces during an open sense-wire diagnostic-measurement scan.

These overrides are only active during the scan; normal configured operation is restored at the end of the scan.

Examples of Normal Sense-Wire Operation

Figure 91 shows the electrical behavior during both odd and even sense-wire open diagnostics when no sense wires are open or compromised.

Table 76. Odd Sense-Wire Open-Measurement Results for Broken Sense Wires

		SENSE-WIRE OPEN-FAULT LOCATION														
		SW0	SW1	SW2	SW3	SW4	SW5	SW6	SW7	SW8	SW9	SW10	SW11	SW12	SW13	SW14
Cell Measurement	Cell1	LO	LO	OK	OK	OK	OK	OK	OK	OK	OK	OK	OK	OK	OK	OK
	Cell2	NM	NM	NM	NM	NM	NM	NM	NM	NM	NM	NM	NM	NM	NM	NM
	Cell3	OK	OK	LO	LO	OK	OK	OK	OK	OK	OK	OK	OK	OK	OK	OK
	Cell4	NM	NM	NM	NM	NM	NM	NM	NM	NM	NM	NM	NM	NM	NM	NM
	Cell5	OK	OK	OK	OK	LO	LO	OK	OK	OK	OK	OK	OK	OK	OK	OK
	Cell6	NM	NM	NM	NM	NM	NM	NM	NM	NM	NM	NM	NM	NM	NM	NM
	Cell7	OK	OK	OK	OK	OK	OK	LO	LO	OK	OK	OK	OK	OK	OK	OK
	Cell8	NM	NM	NM	NM	NM	NM	NM	NM	NM	NM	NM	NM	NM	NM	NM
	Cell9	OK	OK	OK	OK	OK	OK	OK	OK	LO	LO	OK	OK	OK	OK	OK
	Cell10	NM	NM	NM	NM	NM	NM	NM	NM	NM	NM	NM	NM	NM	NM	NM
	Cell11	OK	OK	OK	OK	OK	OK	OK	OK	OK	OK	LO	LO	OK	OK	OK
	Cell12	NM	NM	NM	NM	NM	NM	NM	NM	NM	NM	NM	NM	NM	NM	NM
	Cell13	OK	OK	OK	OK	OK	OK	OK	OK	OK	OK	OK	OK	LO	LO	OK
	Cell14	NM	NM	NM	NM	NM	NM	NM	NM	NM	NM	NM	NM	NM	NM	NM

Note: OK = No error detected; LO = BALLOWTHR violation; NM = Not Measured; Maximum result is 2.5V.

Table 77. Even Sense-Wire Open-Measurement Results for Broken Sense Wires

		SENSE-WIRE OPEN-FAULT LOCATION														
		SW0	SW1	SW2	SW3	SW4	SW5	SW6	SW7	SW8	SW9	SW10	SW11	SW12	SW13	SW14
Cell Measurement	Cell1	NM	NM	NM	NM	NM	NM	NM	NM	NM	NM	NM	NM	NM	NM	NM
	Cell2	OK	LO	LO	OK	OK	OK	OK	OK	OK	OK	OK	OK	OK	OK	OK
	Cell3	NM	NM	NM	NM	NM	NM	NM	NM	NM	NM	NM	NM	NM	NM	NM
	Cell4	OK	OK	OK	LO	LO	OK	OK	OK	OK	OK	OK	OK	OK	OK	OK
	Cell5	NM	NM	NM	NM	NM	NM	NM	NM	NM	NM	NM	NM	NM	NM	NM
	Cell6	OK	OK	OK	OK	OK	LO	LO	OK	OK	OK	OK	OK	OK	OK	OK
	Cell7	NM	NM	NM	NM	NM	NM	NM	NM	NM	NM	NM	NM	NM	NM	NM
	Cell8	OK	OK	OK	OK	OK	OK	OK	LO	LO	OK	OK	OK	OK	OK	OK
	Cell9	NM	NM	NM	NM	NM	NM	NM	NM	NM	NM	NM	NM	NM	NM	NM
	Cell10	OK	OK	OK	OK	OK	OK	OK	OK	OK	LO	LO	OK	OK	OK	OK
	Cell11	NM	NM	NM	NM	NM	NM	NM	NM	NM	NM	NM	NM	NM	NM	NM
	Cell12	OK	OK	OK	OK	OK	OK	OK	OK	OK	OK	OK	LO	LO	OK	OK
	Cell13	NM	NM	NM	NM	NM	NM	NM	NM	NM	NM	NM	NM	NM	NM	NM
	Cell14	OK	OK	OK	OK	OK	OK	OK	OK	OK	OK	OK	OK	OK	LO	LO

Note: OK = No error detected; LO = BALLOWTHR violation; NM = Not measured; Maximum result is 2.5V.

Figure 92 shows the electrical behavior during both odd and even sense-wire open diagnostics when no sense wires are open or compromised, with bus bars included.

Examples of Broken Sense-Wire Fault Detection

Figure 93 shows the electrical behavior during both odd and even sense-wire open diagnostic sequences when a sense-wire in an odd position is broken. The alerts that are issued as a result of the fault are also shown.

Figure 94 and Figure 95 show examples of how broken sense wires are detected and diagnosed using combinations of odd and even sense-wire open diagnostics.

Figure 94 shows the electrical behavior during both odd and even sense-wire open diagnostic sequences when a sense-wire in an even position is broken. The alerts that are issued as a result of the fault are also shown.

Sense-Wire Open-Fault-Detection Results

Table 78. Odd and Even Sense-Wire Open-Measurement Results Overlay for Broken Sense Wires

		SENSE-WIRE OPEN-FAULT LOCATION														
		SW0	SW1	SW2	SW3	SW4	SW5	SW6	SW7	SW8	SW9	SW10	SW11	SW12	SW13	SW14
Cell Measurement	Cell1	LO	LO	OK	OK	OK	OK	OK	OK	OK	OK	OK	OK	OK	OK	OK
	Cell2	OK	LO	LO	OK	OK	OK	OK	OK	OK	OK	OK	OK	OK	OK	OK
	Cell3	OK	OK	LO	LO	OK	OK	OK	OK	OK	OK	OK	OK	OK	OK	OK
	Cell4	OK	OK	OK	LO	LO	OK	OK	OK	OK	OK	OK	OK	OK	OK	OK
	Cell5	OK	OK	OK	OK	LO	LO	OK	OK	OK	OK	OK	OK	OK	OK	OK
	Cell6	OK	OK	OK	OK	OK	LO	LO	OK	OK	OK	OK	OK	OK	OK	OK
	Cell7	OK	OK	OK	OK	OK	OK	LO	LO	OK	OK	OK	OK	OK	OK	OK
	Cell8	OK	OK	OK	OK	OK	OK	OK	LO	LO	OK	OK	OK	OK	OK	OK
	Cell9	OK	OK	OK	OK	OK	OK	OK	OK	LO	LO	OK	OK	OK	OK	OK
	Cell10	OK	OK	OK	OK	OK	OK	OK	OK	OK	LO	LO	OK	OK	OK	OK
	Cell11	OK	OK	OK	OK	OK	OK	OK	OK	OK	OK	LO	LO	OK	OK	OK
	Cell12	OK	OK	OK	OK	OK	OK	OK	OK	OK	OK	OK	LO	LO	OK	OK
	Cell13	OK	OK	OK	OK	OK	OK	OK	OK	OK	OK	OK	OK	LO	LO	OK
	Cell14	OK	OK	OK	OK	OK	OK	OK	OK	OK	OK	OK	OK	OK	LO	LO

Note: OK = No Error Detected; LO = ALLOWTHR Violation; Maximum result is 2.5V

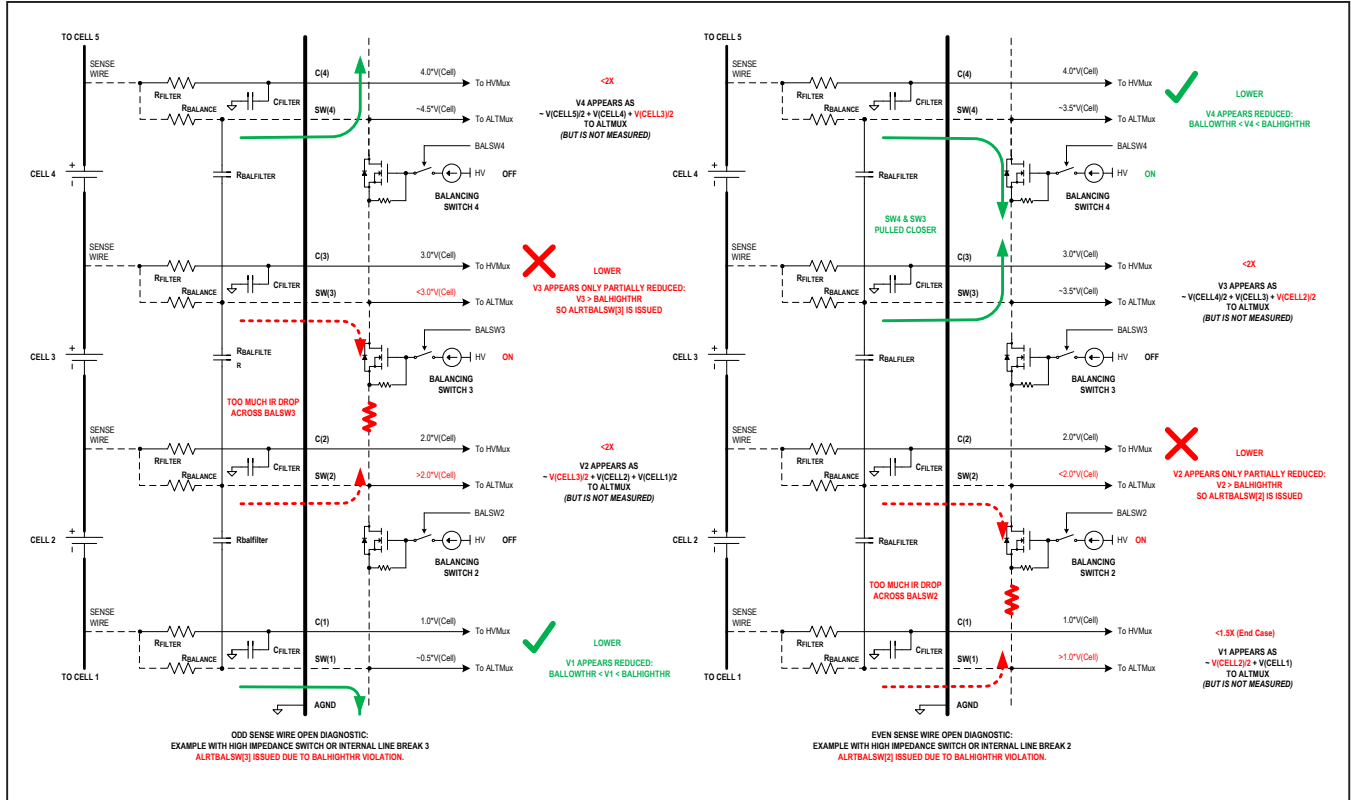

Figure 95. Cell Sense-Wire Open-Diagnostic Operations (Example with Broken BALSW or Internal Trace)

Table 79. Odd and Even Sense-Wire Open-Measurement Results Overlay for Broken Sense Wires

		SWITCH OR TRACE FAULT LOCATION (BALSW)													
		1	2	3	4	5	6	7	8	9	10	11	12	13	14
Cell Measurement	Cell1	HI	OK	OK	OK	OK	OK	OK	OK	OK	OK	OK	OK	OK	OK
	Cell2	OK	HI	OK	OK	OK	OK	OK	OK	OK	OK	OK	OK	OK	OK
	Cell3	OK	OK	HI	OK	OK	OK	OK	OK	OK	OK	OK	OK	OK	OK
	Cell4	OK	OK	OK	HI	OK	OK	OK	OK	OK	OK	OK	OK	OK	OK
	Cell5	OK	OK	OK	OK	HI	OK	OK	OK	OK	OK	OK	OK	OK	OK
	Cell6	OK	OK	OK	OK	OK	HI	OK	OK	OK	OK	OK	OK	OK	OK
	Cell7	OK	OK	OK	OK	OK	OK	HI	OK	OK	OK	OK	OK	OK	OK
	Cell8	OK	OK	OK	OK	OK	OK	OK	HI	OK	OK	OK	OK	OK	OK
	Cell9	OK	OK	OK	OK	OK	OK	OK	OK	HI	OK	OK	OK	OK	OK
	Cell10	OK	OK	OK	OK	OK	OK	OK	OK	OK	HI	OK	OK	OK	OK
	Cell11	OK	OK	OK	OK	OK	OK	OK	OK	OK	OK	HI	OK	OK	OK
	Cell12	OK	OK	OK	OK	OK	OK	OK	OK	OK	OK	OK	HI	OK	OK
	Cell13	OK	OK	OK	OK	OK	OK	OK	OK	OK	OK	OK	OK	HI	OK
	Cell14	OK	OK	OK	OK	OK	OK	OK	OK	OK	OK	OK	OK	OK	HI

Note: OK = No error detected, LO = BALLOWTHR violation, Maximum result is 2.5V

[Table 76](#) shows the measurement alerts that correspond to a break in each sense-wire position during an odd sense-wire open diagnostic. When combined with the results from an even sense-wire open diagnostic, the exact location of the sense-wire fault can be determined.

[Table 77](#) shows the measurement alerts that correspond to a break in each sense-wire position during an even sense-wire open diagnostic. When combined with the results from an odd sense-wire open diagnostic, the exact location of the sense-wire fault can be determined.

When combined together, the two diagnostics can identify the exact location of a broken sense wire. The combined diagnostic results are shown in [Table 78](#).

Examples of Broken Internal Switch and Trace-Fault Detection

[Figure 95](#) shows the electrical behavior during both odd and even sense-wire open-diagnostic sequences when there is a fault in an internal switch or connection. The alerts that are issued as a result of the fault are also shown.

[Figure 96](#) shows examples of how broken-sense wires are detected and diagnosed using combinations of odd and even sense-wire open diagnostics.

Broken-Switch Fault-Detection Results

When combined together, the two diagnostics can cover and identify the exact location of a faulty switch or internal trace. The combined diagnostic results are shown in [Table 79](#). Notice that unlike a broken sense wire, only a single ALRTBALSW alert is issued for faults of this type.

ADC End-of-Scan Diagnostics

This diagnostic is performed at the end of a measurement-sequence that is configured to use the ADC (SCANCFG = 0b000 or 0b001) when ADCZSFSEN=1. The ADC measurements are taken in bipolar mode.

For full-scale diagnostic: $ADC_{REF} = V_{REF}$ and $ADC_{IN} = V_{AA}$.

If the result from the ADC is less than FFFh (12-bit result), an alert is issued by setting the ALRTADCFS bit in the FMEA2 register.

Register Map

MAX17853 User Register Map

Register Map Usage Guidelines

The register map (RMap) for the MAX17853 is detailed in the following sections. General-usage guidelines pertaining to the entire RMap are outlined here, detailing the expected usage of the RMap, including how various protocol and access issues are handled.

Interface Protocol Errors

For read and write transactions to be accepted, all interface-protocol expectations must be met. If protocol errors occur, they are reported through alerts in the STATUS1 and STATUS2 registers, notifying the user of the issue observed. If a protocol error occurs, none of the behaviors listed below apply, because the transaction will be rejected, even if the transaction addresses a Reserved register address. See the UART and SPI Interface descriptions for complete details on expected interface protocols.

Reserved Registers

All user-accessible registers are contained in the address space between 0x00 and 0x98. Any address/register in this space not specifically listed in the RMap should be treated as Reserved; for the MAX17853, the following addresses within the user address space are reserved: 0x2C, 0x2D, 0x2E, 0x2F, 0x46, and 0x84 through 0x8B. The address space 0x99 to 0xFF is also reserved for Maxim Use Only.

If an otherwise valid attempt to read or write to a reserved register address occurs (with no protocol or CRC/PEC errors), no errors are issued for the SPI/UART transaction. No data written to a reserved register address are internally stored, and reserved registers always read back all zeros. If a UART block readback request includes any reserved register addresses, the addresses will be included in the readback data, with all zeros returned; no addresses are skipped during UART block readback transactions. Users should normally avoid writing to reserved registers, as the MAX17853 will not respond to such transactions.

Unused Bitfields

Within the user-accessible registers, there are many unused bitfields, denoted by a dash (-) in the RMap. During read and write transactions, PEC and CRC checks apply to all 16 bits of data, including any unused bitfields. No data written to an unused bitfield is internally stored, and unused bitfields always read back all zeros.

Reserved Bitfields

Within the RMap, there are two reserved bitfields, DEVCFG1RSRV (1 bit) and DEVCFG2RSRV (4 bits); these are reserved for future use. During read and write transactions, PEC and CRC checks apply to all 16 bits of data, including any reserved bitfields. Data written to a reserved bitfield will be internally stored (though the settings of these bitfields have no effect on internal operations), and the reserved bitfields always read back their current settings.

Register Blocks and Transaction-Reject Behavior

The RMap is organized into several register blocks. Each register block is subject to specific transaction-rejection behaviors, as detailed in the register block descriptions

that follow. These behaviors ensure that register content currently in use by any requested internal process is not subject to alteration while in use. In general, the register blocks are organized and defined to provide maximum transaction efficiency, while also ensuring the ultimate level of safety.

If a valid write transaction to a blocked (busy) register occurs, the transaction is rejected and the ALRTRJCT bit set, indicating the write was ignored since that register was currently being used by an ongoing internal operation. In general, user software should be written to avoid modifying register content that is currently in use, instead confirming that the internal process has completed before any modifications are written to the MAX17853.

ADDRESS	NAME	MSB							LSB	
STATUS Registers										
<u>0x00</u>	VERSION[15:8]	MOD[11:4]								
	VERSION[7:0]	MOD[3:0]				VER[3:0]				
<u>0x01</u>	ADDRESS[15:8]	ADDRUN-LOCK	BA[4:0]					TA[4:3]		
	ADDRESS[7:0]	TA[2:0]			DA[4:0]					
<u>0x02</u>	STATUS1[15:8]	ALRTSCAN	ALRTRST	ALRT-MSMTCH	ALRTCEL-LOVST	ALRTCEL-LUVST	ALRT-BLKOVST	ALRT-BLKUVST	ALR-TAUXOVST	
	STATUS1[7:0]	ALRTAUX-UVST	-	ALRTPEC	ALRTIN-TRFC	ALRTCAL	ALRT-CBAL	ALRT-FMEA2	ALRT-FMEA1	
<u>0x03</u>	STATUS2[15:8]	ALRTPE-CUP	ALRTP-ECDN	ALRT-MANUP	ALRT-MANDN	ALRTPA-RUP	ALRT-PARDN	ALRTDU-ALUART	-	
	STATUS2[7:0]	ALRTSPI	ALRTSCLK-ERR	ALR-TOSC3	ALRTINT-BUS	-	-	-	ALRTRJCT	
<u>0x04</u>	STATUS3[15:8]	ALRTCB-TIMEOUT	ALRTCB-TEMP	ALRTCB-CAL	ALRT-CBNTFY	ALRTCB-DONE	-	-	-	
	STATUS3[7:0]	-	-	-	-	-	-	-	-	
<u>0x05</u>	FMEA1[15:8]	ALR-TOSC1	ALR-TOSC2	ALRT-COM-MSEU1	ALRT-COM-MSEL1	ALRCOM-MSEU2	ALRT-COM-MSEL2	ALRT-VDDL3	ALRT-VDDL2	
	FMEA1[7:0]	ALRT-VDDL1	ALRT-GNDL3	ALRT-GNDL2	ALRT-GNDL1	ALRTH-VUV	ALRTHVH-DRM	ALRTH-VOV	ALRT-BALS-WSUM	
<u>0x06</u>	FMEA2[15:8]	ALRTUS-ER	ALRTD-CINMUX	ALRTAUX-PRCT-SUM	ALRT-TEMP	ALRTSCAN-TIMEOUT	-	-	-	
	FMEA2[7:0]	-	-	-	-	ALRTAD-CZS	ALRTAD-CFS	ALRT-COMPAC-COV	ALRT-COMPAC-CUV	

ADDRESS	NAME	MSB							LSB
0x07	ALRTSUM[15:8]	ALRTAD- COVST	ALRT- COM- POVST	ALRTAD- CUVST	ALRT- COMPU- VST	ALRTAD- CAUXOVST	ALRTCOM- PAUXOVST	ALRTAD- CAUXU- VST	ALRT- COM- PAUXU- VST
	ALRTSUM[7:0]	-	-	-	ALRT- CALO- SADC	ALRT- CALOSR	ALRT- CALO- STHRM	ALRTCAL- GAINP	ALRTCAL- GAINR
0x08	ALRTOVCELL[15:8]	-	-	ALRTOV[14:9]					
	ALRTOVCELL[7:0]	ALRTOV[8:1]							
0x09	ALRTUVCELL[15:8]	-	-	ALRTUV[14:9]					
	ALRTUVCELL[7:0]	ALRTUV[8:1]							
0x0A	MINMAXCELL[15:8]	-	-	-	-	MAXCELL[3:0]			
	MINMAXCELL[7:0]	-	-	-	-	MINCELL[3:0]			
0x0B	ALRTAUXPRTC- TREG[15:8]	-	-	-	-	-	-	-	-
	ALRTAUXPRTCTREG[7:0]	-	-	ALRTAUXPRTCT[5:4]	ALRTAUXPRTCT[3:0]				
0x0C	ALRTAUXOVREG[15:8]	-	-	-	-	-	-	-	-
	ALRTAUXOVREG[7:0]	-	-	ALRTAUXOV[5:4]	ALRTAUXOV[3:0]				
0x0D	ALRTAUXUVREG[15:8]	-	-	-	-	-	-	-	-
	ALRTAUXUVREG[7:0]	-	-	ALRTAUXUV[5:4]	ALRTAUXUV[3:0]				
0x0E	ALRTCOMPOVREG[15:8]	-	-	ALRTCOMPOV[14:9]					
	ALRTCOMPOVREG[7:0]	ALRTCOMPOV[8:1]							
0x0F	ALRTCOMPUVREG[15:8]	-	-	ALRTCOMPUV[14:9]					
	ALRTCOMPUVREG[7:0]	ALRTCOMPUV[8:1]							
0x10	ALRTCOM- PAUXOVREG[15:8]	-	-	-	-	-	-	-	-
	ALRTCOM- PAUXOVREG[7:0]	-	-	ALRTCOM- PAUXOV[5:4]	ALRTCOMPAUXOV[3:0]				
0x11	ALRTCOMPAUXUVREG[15:8]	-	-	-	-	-	-	-	-
	ALRTCOMPAUXUVREG[7:0]	-	-	ALRTCOMPAUX- UV[5:4]	ALRTCOMPAUXUV[3:0]				
0x12	ALRTBALSWREG[15:8]	-	-	ALRTBALSW[13:8]					
	ALRTBALSWREG[7:0]	ALRTBALSW[7:0]							
0x13	SWACTION[15:8]	-	-	-	-	-	-	-	-
	SWACTION[7:0]	-	-	-	-	-	-	-	SWPOR
GENERAL CONFIGURATION Registers									
0x14	DEVCFG1[15:8]	UARTCFG[1:0]		TXUIDLE- HIZ	TXLIDLE- HIZ	ADAPTTXEN[1:0]		ALIVECNT- EN	UAR- THOST
	DEVCFG1[7:0]	SFTYCSB	SFTYSCLK	SFTYSDI	SPI- DRVINT	DEVCF- G1RSRV	NOPEC	ALERTEN	DBLBUFEN
0x15	DEVCFG2[15:8]	IIRFC[2:0]			-	DEVCFG2RSRV[3:0]			
	DEVCFG2[7:0]	-	HVCPDIS	FORCE- POR	ALERT- DCTSTEN	-	SPITODIS	SCANTO- DIS	CBTODIS

ADDRESS	NAME	MSB							LSB
<u>0x16</u>	AUXGPIOCFG[15:8]	–	–	GPIOEN[5:4]		GPIOEN[3:0]			
	AUXGPIOCFG[7:0]	–	–	GPIODIR[5:4]		GPIODIR[3:0]			
<u>0x17</u>	GPIOCFG[15:8]	–	–	GPIODRV[5:4]		GPIODRV[3:0]			
	GPIOCFG[7:0]	–	–	GPIORD[5:4]		GPIORD[3:0]			
<u>0x18</u>	PACKCFG[15:8]	FLXPCK-EN2	FLXPCK-EN1	FLXPCK-SCAN	–	TOPBLOCK[3:0]			
	PACKCFG[7:0]	TOPCELL2[3:0]				TOPCELL1[3:0]			
ALERT CONFIGURATION Registers									
<u>0x19</u>	ALRTIRQEN[15:8]	SCAN-ALRTEN	–	MSMTCH-ALRTEN	CEL-LOVST-ALRTEN	CEL-LUVST-ALRTEN	BLKOVST-ALRTEN	BLKUVST-ALRTEN	AUXOVST-ALRTEN
	ALRTIRQEN[7:0]	AUXUVST-ALRTEN	–	PEC-ALRTEN	INTRFC-ALRTEN	CAL-ALRTEN	CBAL-ALRTEN	FMEA-2ALRTEN	FMEA-1ALRTEN
<u>0x1A</u>	ALRTOVEN[15:8]	–	BLKOV-ALRTEN	OVALRTEN[14:9]					
	ALRTOVEN[7:0]	OVALRTEN[8:1]							
<u>0x1B</u>	ALRTUVEN[15:8]	–	BLKUV-ALRTEN	UVALRTEN[14:9]					
	ALRTUVEN[7:0]	UVALRTEN[8:1]							
<u>0x1C</u>	ALRTAUXOVEN[15:8]	–	–	–	–	–	–	–	–
	ALRTAUXOVEN[7:0]	–	–	AUXOVALRTEN[5:4]		AUXOVALRTEN[3:0]			
<u>0x1D</u>	ALRTAUXUVEN[15:8]	–	–	–	–	–	–	–	–
	ALRTAUXUVEN[7:0]	–	–	AUXUVALRTEN[5:4]		AUXUVALRTEN[3:0]			
<u>0x1E</u>	ALRTCALTST[15:8]	–	–	–	–	–	–	–	–
	ALRTCALTST[7:0]	–	–	–	CALOS-ADC-ALRTFRC	CALOSR-ALRTFRC	CALOSTHRM-ALRTFRC	CALGAIN-PALRT-FRC	CALGAIN-RALRT-FRC
THRESHOLD Registers									
<u>0x1F</u>	OVTHCLRREG[15:8]	OVTHCLR[13:6]							
	OVTHCLRREG[7:0]	OVTHCLR[5:0]						–	–
<u>0x20</u>	OVTHSETREG[15:8]	OVTHSET[13:6]							
	OVTHSETREG[7:0]	OVTHSET[5:0]						–	–
<u>0x21</u>	UVTHCLRREG[15:8]	UVTHCLR[13:6]							
	UVTHCLRREG[7:0]	UVTHCLR[5:0]						–	–
<u>0x22</u>	UVTHSETREG[15:8]	UVTHSET[13:6]							
	UVTHSETREG[7:0]	UVTHSET[5:0]						–	–
<u>(0x23)</u>	MSMTCHREG[15:8]	MSMTCH[13:6]							
	MSMTCHREG[7:0]	MSMTCH[5:0]						–	–
<u>0x24</u>	BIPOVTHCLRREG[15:8]	BIPOVTHCLR[13:6]							
	BIPOVTHCLRREG[7:0]	BIPOVTHCLR[5:0]						–	–
<u>0x25</u>	BIPOVTHSETREG[15:8]	BIPOVTHSET[13:6]							
	BIPOVTHSETREG[7:0]	BIPOVTHSET[5:0]						–	–

ADDRESS	NAME	MSB						LSB
<u>0x26</u>	BIPUVTHCLRREG[15:8]	BIPUVTHCLR[13:6]						
	BIPUVTHCLRREG[7:0]	BIPUVTHCLR[5:0]					-	-
<u>0x27</u>	BIPUVTHSETREG[15:8]	BIPUVTHSET[13:6]						
	BIPUVTHSETREG[7:0]	BIPUVTHSET[5:0]					-	-
<u>0x28</u>	BLKOVTHCLRREG[15:8]	BLKOVTHCLR[13:6]						
	BLKOVTHCLRREG[7:0]	BLKOVTHCLR[5:0]					-	-
<u>0x29</u>	BLKOVTHSETREG[15:8]	BLKOVTHSET[13:6]						
	BLKOVTHSETREG[7:0]	BLKOVTHSET[5:0]					-	-
<u>0x2A</u>	BLKUVTHCLRREG[15:8]	BLKUVTHCLR[13:6]						
	BLKUVTHCLRREG[7:0]	BLKUVTHCLR[5:0]					-	-
<u>0x2B</u>	BLKUVTHSETREG[15:8]	BLKUVTHSET[13:6]						
	BLKUVTHSETREG[7:0]	BLKUVTHSET[5:0]					-	-
<u>0x30</u>	AUXROVTHCLRREG[15:8]	AUXROVTHCLR[13:6]						
	AUXROVTHCLRREG[7:0]	AUXROVTHCLR[5:0]					-	-
<u>0x31</u>	AUXROVTHSETREG[15:8]	AUXROVTHSET[13:6]						
	AUXROVTHSETREG[7:0]	AUXROVTHSET[5:0]					-	-
<u>0x32</u>	AUXRUVTHCLRREG[15:8]	AUXRUVTHCLR[13:6]						
	AUXRUVTHCLRREG[7:0]	AUXRUVTHCLR[5:0]					-	-
<u>0x33</u>	AUXRUVTHSETREG[15:8]	AUXRUVTHSET[13:6]						
	AUXRUVTHSETREG[7:0]	AUXRUVTHSET[5:0]					-	-
<u>0x34</u>	AUXAOVTHCLRREG[15:8]	AUXAOVTHCLR[13:6]						
	AUXAOVTHCLRREG[7:0]	AUXAOVTHCLR[5:0]					-	-
<u>(0x35)</u>	AUXAOVTHSETREG[15:8]	AUXAOVTHSET[13:6]						
	AUXAOVTHSETREG[7:0]	AUXAOVTHSET[5:0]					-	-
<u>0x36</u>	AUXAUVTHCLRREG[15:8]	AUXAUVTHCLR[13:6]						
	AUXAUVTHCLRREG[7:0]	AUXAUVTHCLR[5:0]					-	-
<u>0x37</u>	AUXAUVTHSETREG[15:8]	AUXAUVTHSET[13:6]						
	AUXAUVTHSETREG[7:0]	AUXAUVTHSET[5:0]					-	-
<u>0x38</u>	COMPOVTHREG[15:8]	COMPOVTH[9:2]						
	COMPOVTHREG[7:0]	COMPOVTH[1:0]	-	-	-	-	-	-
<u>0x39</u>	COMPUVTHREG[15:8]	COMPUVTH[9:2]						
	COMPUVTHREG[7:0]	COMPUVTH[1:0]	-	-	-	-	-	-
<u>0x3A</u>	COMPAUXROVTHREG[15:8]	COMPAUXROVTH[9:2]						
	COMPAUXROVTHREG[7:0]	COMPAUXROVTH[1:0]	-	-	-	-	-	-
<u>0x3B</u>	COMPAUXRUVTHREG[15:8]	COMPAUXRUVTH[9:2]						
	COMPAUXRUVTHREG[7:0]	COMPAUXRUVTH[1:0]	-	-	-	-	-	-
<u>0x3C</u>	COMPAUXAOVTHREG[15:8]	COMPAUXAOVTH[9:2]						
	COMPAUXAOVTHREG[7:0]	COMPAUXAOVTH[1:0]	-	-	-	-	-	-
<u>0x3D</u>	COMPAUXAUVTHREG[15:8]	COMPAUXAUVTH[9:2]						
	COMPAUXAUVTHREG[7:0]	COMPAUXAUVTH[1:0]	-	-	-	-	-	-

ADDRESS	NAME	MSB							LSB
DIAGNOSTIC THRESHOLD Registers									
0x3E	COMPOPNTHREG[15:8]	COMPOPNTH[9:2]							
	COMPOPNTHREG[7:0]	COMPOPNTH[1:0]	-	-	-	-	-	-	-
0x3F	COMPAUXROPNTHREG[15:8]	COMPAUXROPNTH[9:2]							
	COMPAUXROPNTHREG[7:0]	COMPAUXROPNTH[1:0]	-	-	-	-	-	-	-
0x40	COMPAUXAOPNTHREG[15:8]	COMPAUXAOPNTH[9:2]							
	COMPAUXAOPNTHREG[7:0]	COMPAUXAOPNTH[1:0]	-	-	-	-	-	-	-
0x41	COMPACCOVTHREG[15:8]	COMPACCOVTH[9:2]							
	COMPACCOVTHREG[7:0]	COMPACCOVTH[1:0]	-	-	-	-	-	-	-
0x42	COMPACCUVTHREG[15:8]	COMPACCUVTH[9:2]							
	COMPACCUVTHREG[7:0]	COMPACCUVTH[1:0]	-	-	-	-	-	-	-
0x43	BALSHRTTHRREG[15:8]	BALSHRTTHR[13:6]							
	BALSHRTTHRREG[7:0]	BALSHRTTHR[5:0]						-	-
(0x44)	BALLOWTHRREG[15:8]	BALLOWTHR[13:6]							
	BALLOWTHRREG[7:0]	BALLOWTHR[5:0]						-	-
0x45	BALHIGHTHRREG[15:8]	BALHIGHTHR[13:6]							
	BALHIGHTHRREG[7:0]	BALHIGHTHR[5:0]						-	-
CELL DATA Registers									
0x47	CELL1REG[15:8]	CELL1[13:6]							
	CELL1REG[7:0]	CELL1[5:0]						-	-
0x48	CELL2REG[15:8]	CELL2[13:6]							
	CELL2REG[7:0]	CELL2[5:0]						-	-
0x49	CELL3REG[15:8]	CELL3[13:6]							
	CELL3REG[7:0]	CELL3[5:0]						-	-
0x4A	CELL4REG[15:8]	CELL4[13:6]							
	CELL4REG[7:0]	CELL4[5:0]						-	-
0x4B	CELL5REG[15:8]	CELL5[13:6]							
	CELL5REG[7:0]	CELL5[5:0]						-	-
0x4C	CELL6REG[15:8]	CELL6[13:6]							
	CELL6REG[7:0]	CELL6[5:0]						-	-
(0x4D)	CELL7REG[15:8]	CELL7[13:6]							
	CELL7REG[7:0]	CELL7[5:0]						-	-
0x4E	CELL8REG[15:8]	CELL8[13:6]							
	CELL8REG[7:0]	CELL8[5:0]						-	-
0x4F	CELL9REG[15:8]	CELL9[13:6]							
	CELL9REG[7:0]	CELL9[5:0]						-	-
0x50	CELL10REG[15:8]	CELL10[13:6]							
	CELL10REG[7:0]	CELL10[5:0]						-	-
0x51	CELL11REG[15:8]	CELL11[13:6]							
	CELL11REG[7:0]	CELL11[5:0]						-	-

ADDRESS	NAME	MSB							LSB
0x52	CELL12REG[15:8]	CELL12[13:6]							
	CELL12REG[7:0]	CELL12[5:0]						-	-
0x53	CELL13REG[15:8]	CELL13[13:6]							
	CELL13REG[7:0]	CELL13[5:0]						-	-
0x54	CELL14REG[15:8]	CELL14[13:6]							
	CELL14REG[7:0]	CELL14[5:0]						-	-
0x55	BLOCKREG[15:8]	VBLOCK[13:6]							
	BLOCKREG[7:0]	VBLOCK[5:0]						-	-
TOTAL DIAG AUX DATA Registers									
0x56	TOTALREG[15:8]	TOTAL[15:8]							
	TOTALREG[7:0]	TOTAL[7:0]							
0x57	DIAG1REG[15:8]	DIAG1[13:6]							
	DIAG1REG[7:0]	DIAG1[5:0]						-	-
0x58	DIAG2REG[15:8]	DIAG2[13:6]							
	DIAG2REG[7:0]	DIAG2[5:0]						-	-
0x59	AUX0REG[15:8]	AUX0[13:6]							
	AUX0REG[7:0]	AUX0[5:0]						-	-
0x5A	AUX1REG[15:8]	AUX1[13:6]							
	AUX1REG[7:0]	AUX1[5:0]						-	-
0x5B	AUX2REG[15:8]	AUX2[13:6]							
	AUX2REG[7:0]	AUX2[5:0]						-	-
0x5C	AUX3REG[15:8]	AUX3[13:6]							
	AUX3REG[7:0]	AUX3[5:0]						-	-
0x5D	AUX4REG[15:8]	AUX4[13:6]							
	AUX4REG[7:0]	AUX4[5:0]						-	-
0x5E	AUX5REG[15:8]	AUX5[13:6]							
	AUX5REG[7:0]	AUX5[5:0]						-	-
SCAN SETTINGS Registers									
0x5F	POLARITYCTRL[15:8]	MINMAX-POL	-	POLARITY[14:9]					
	POLARITYCTRL[7:0]	POLARITY[8:1]							
0x60	AUXREFCTRL[15:8]	-	-	-	-	-	-	-	-
	AUXREFCTRL[7:0]	-	-	AUXREFSEL[5:4]		AUXREFSEL[3:0]			
0x61	AUXTIMEREG[15:8]	-	-	-	-	-	-	AUXTIME[9:8]	
	AUXTIMEREG[7:0]	AUXTIME[7:0]							
0x62	ACQCFG[15:8]	ADCZSF-SEN	ADC-CALEN	COMPAC-CEN	FOSR[1:0]		THRMMODE[1:0]		-
	ACQCFG[7:0]	-	-	-	-	-	-	-	-
0x63	BALSWDLY[15:8]	CELLDLY[7:0]							
	BALSWDLY[7:0]	SWDLY[7:0]							

ADDRESS	NAME	MSB							LSB
SCAN CONTROL Registers									
0x64	MEASUREEN1[15:8]	–	BLOCKEN	CELLEN[14:9]					
	MEASUREEN1[7:0]	CELLEN[8:1]							
0x65	MEASUREEN2[15:8]	SCAN-IRINIT	–	–	–	–	–	–	–
	MEASUREEN2[7:0]	–	–	AUXEN[5:4]			AUXEN[3:0]		
0x66	SCANCTRL[15:8]	SCAN-DONE	SCANTIME-OUT	DATARDY	AUTO-BALSW-DIS	ALRTFILT-SEL	AMEND-FILT	RDFILT	SCAN-CFG[2]
	SCANCTRL[7:0]	SCANCFG[1:0]		OVSAMPL[2:0]			ALTMUX-SEL	SCAN-MODE	SCAN
DIAGNOSTIC SETTINGS Registers									
0x67	ADCTEST1AREG[15:8]	ADCTSTEN	–	–	–	ADCTEST1A[11:8]			
	ADCTEST1AREG[7:0]	ADCTEST1A[7:0]							
0x68	ADCTEST1BREG[15:8]	–	–	–	–	ADCTEST1B[11:8]			
	ADCTEST1BREG[7:0]	ADCTEST1B[7:0]							
0x69	ADCTEST2AREG[15:8]	–	–	–	–	ADCTEST2A[11:8]			
	ADCTEST2AREG[7:0]	ADCTEST2A[7:0]							
0x6A	ADCTEST2BREG[15:8]	–	–	–	–	ADCTEST2B[11:8]			
	ADCTEST2BREG[7:0]	ADCTEST2B[7:0]							
DIAGNOSTIC CONTROL Registers									
0x6B	DIAGCFG[15:8]	CTSTDAC[3:0]				CTSTSRC	MUXDIAG-BUS	MUXDIAG-PAIR	MUXDIAG-GEN
	DIAGCFG[7:0]	DIAGSEL2[3:0]				DIAGSEL1[3:0]			
0x6C	CTSTCFG[15:8]	CEL-LOPNDI-AGSEL	CTSTEN[14:8]						
	CTSTCFG[7:0]	CTSTEN[7:0]							
0x6D	AUXTSTCFG[15:8]	–	–	–	–	–	–	–	–
	AUXTSTCFG[7:0]	–	–	AUXTSTEN[5:4]			AUXTSTEN[3:0]		
0x6E	DIAGGENCFG[15:8]	AUXDIAGSEL[2:0]			–	–	–	–	–
	DIAGGENCFG[7:0]	–	–	–	–	–	–	–	–
CELL-BALANCING Registers									
0x6F	BALSWCTRL[15:8]	CBRE-START	–	BALSWEN[14:9]					
	BALSWCTRL[7:0]	BALSWEN[8:1]							
0x70	BALEXP1[15:8]	–	–	–	–	–	–	CBEXP1[9:8]	
	BALEXP1[7:0]	CBEXP1[7:0]							
0x71	BALEXP2[15:8]	–	–	–	–	–	–	CBEXP2[9:8]	
	BALEXP2[7:0]	CBEXP2[7:0]							

ADDRESS	NAME	MSB						LSB
0x72	BALEXP3[15:8]	-	-	-	-	-	-	CBEXP3[9:8]
	BALEXP3[7:0]	CBEXP3[7:0]						
0x73	BALEXP4[15:8]	-	-	-	-	-	-	CBEXP4[9:8]
	BALEXP4[7:0]	CBEXP4[7:0]						
0x74	BALEXP5[15:8]	-	-	-	-	-	-	CBEXP5[9:8]
	BALEXP5[7:0]	CBEXP5[7:0]						
0x75	BALEXP6[15:8]	-	-	-	-	-	-	CBEXP6[9:8]
	BALEXP6[7:0]	CBEXP6[7:0]						
0x76	BALEXP7[15:8]	-	-	-	-	-	-	CBEXP7[9:8]
	BALEXP7[7:0]	CBEXP7[7:0]						
0x77	BALEXP8[15:8]	-	-	-	-	-	-	CBEXP8[9:8]
	BALEXP8[7:0]	CBEXP8[7:0]						
0x78	BALEXP9[15:8]	-	-	-	-	-	-	CBEXP9[9:8]
	BALEXP9[7:0]	CBEXP9[7:0]						
0x79	BALEXP10[15:8]	-	-	-	-	-	-	CBEXP10[9:8]
	BALEXP10[7:0]	CBEXP10[7:0]						
0x7A	BALEXP11[15:8]	-	-	-	-	-	-	CBEXP11[9:8]
	BALEXP11[7:0]	CBEXP11[7:0]						
0x7B	BALEXP12[15:8]	-	-	-	-	-	-	CBEXP12[9:8]
	BALEXP12[7:0]	CBEXP12[7:0]						
0x7C	BALEXP13[15:8]	-	-	-	-	-	-	CBEXP13[9:8]
	BALEXP13[7:0]	CBEXP13[7:0]						
0x7D	BALEXP14[15:8]	-	-	-	-	-	-	CBEXP14[9:8]
	BALEXP14[7:0]	CBEXP14[7:0]						
0x7E	BALAUTOUVTHR[15:8]	CBUVTHR[13:6]						
	BALAUTOUVTHR[7:0]	CBUVTHR[5:0]						-
0x7F	BALDLYCTRL[15:8]	-	-	-	-	-	-	CBNTFYCFG[1:0]
	BALDLYCTRL[7:0]	-	-	-	-	-	CBCALDLY[2:0]	
0x80	BALCTRL[15:8]	CBACTIVE[1:0]		CBMODE[2:0]		CBIIRINIT	HOLDSHDNL[1:0]	
	BALCTRL[7:0]	CBDUTY[3:0]			CBDONE-ALRTEN	CBTEMPEN	CBMEASEN[1:0]	
0x81	BALSTAT[15:8]	CBACTIVE_M1[1:0]		CBUNIT[1:0]	CBCNTR[1:0]		CBTIMER[9:8]	
	BALSTAT[7:0]	CBTIMER[7:0]						
0x82	BALUVSTAT[15:8]	CBACTIVE_M2[1:0]		CBUVSTAT[14:9]				
	BALUVSTAT[7:0]	CBUVSTAT[8:1]						

ADDRESS	NAME	MSB						LSB
<u>0x83</u>	BALDATA[15:8]	CBACTIVE_M3[1:0]		DATAR-DY_M	-	-	-	-
	BALDATA[7:0]	-	-	-	-	-	-	CBSCAN
ROM SUPPORT Registers								
<u>0x8C</u>	ID1[15:8]				DEVID[15:8]			
	ID1[7:0]				DEVID[7:0]			
<u>0x8D</u>	ID2[15:8]				DEVID[31:24]			
	ID2[7:0]				DEVID[23:16]			
<u>0x8E</u>	OTP2[15:8]				OTP2[15:8]			
	OTP2[7:0]				OTP2[7:0]			
<u>0x8F</u>	OTP3[15:8]				OTP3[15:8]			
	OTP3[7:0]				OTP3[7:0]			
<u>0x90</u>	OTP4[15:8]				OTP4[15:8]			
	OTP4[7:0]				OTP4[7:0]			
<u>0x91</u>	OTP5[15:8]				OTP5[15:8]			
	OTP5[7:0]				OTP5[7:0]			
<u>0x92</u>	OTP6[15:8]				OTP6[15:8]			
	OTP6[7:0]				OTP6[7:0]			
<u>0x93</u>	OTP7[15:8]				OTP7[15:8]			
	OTP7[7:0]				OTP7[7:0]			
<u>0x94</u>	OTP8[15:8]				OTP8[15:8]			
	OTP8[7:0]				OTP8[7:0]			
<u>0x95</u>	OTP9[15:8]				OTP9[15:8]			
	OTP9[7:0]				OTP9[7:0]			
<u>0x96</u>	OTP10[15:8]				OTP10[15:8]			
	OTP10[7:0]				OTP10[7:0]			
<u>0x97</u>	OTP11[15:8]				OTP11[15:8]			
	OTP11[7:0]				OTP11[7:0]			
<u>0x98</u>	OTP12[15:8]				ROMCRC[7:0]			
	OTP12[7:0]				OTP12[7:0]			

Register Details

VERSION (0x00)

VERSION is a read-only-accessible register that returns information on the device.

BIT	15	14	13	12	11	10	9	8
Field	MOD[11:4]							
Reset								
Access Type	Read Only							
BIT	7	6	5	4	3	2	1	0
Field	MOD[3:0]				VER[3:0]			
Reset					0x05			
Access Type	Read Only				Read Only			

BITFIELD	BITS	DESCRIPTION
MOD	15:4	Device Model Number: 0x853 = MAX17853 Read only.
VER	3:0	Si Version: 0x05 Read only.

ADDRESS (0x01)

ADDRESS is a read-/write-accessible register that sets the first, last, and device address used by a device in a UART chain (UARTSEL = 1).

This register has no effect on a device operating in SPI mode (UARTSEL = 0).

BIT	15	14	13	12	11	10	9	8	
Field	ADDRUN-LOCK	BA[4:0]						TA[4:3]	
Reset	0b1	0b0_0000						0b0_0000	
Access Type	Write, Read, Ext	Write, Read, Ext						Write, Read, Ext	
BIT	7	6	5	4	3	2	1	0	
Field	TA[2:0]			DA[4:0]					
Reset	0b0_0000			0b0_0000					
Access Type	Write, Read, Ext			Write, Read, Ext					

BITFIELD	BITS	DESCRIPTION
ADDRUNLOCK	15	<p>UART Device Address Unlock: 0 = Normal operation (following HELLOALL) 1 = Disable write-protection of device address DA[4:0], allowing resends of HELLOALL to reassign device addresses without POR (also POR default). Cleared only by HELLOALL command (writes to zero are ignored). This bitfield is unaffected in the event of a software POR (SWPOR) request by the host.</p> <p>Note: This bit should normally be written to zero when populating BA and TA content, it should only be necessary to set this bit if the user believes the original DA content populated by the HELLOALL command is corrupted.</p>
BA	14:10	<p>Bottom-Device Address in a UART Chain: Address of the device at the bottom of the daisy-chain. If the host sends an initial address other than 0x00 in the HELLOALL command through the UART Up path (assign/increment), the host must write that bottom address (as well as the expected top address) to all devices in the daisy-chain with a WRITEALL command to this bitfield. READALL commands and Alert Packets require that BA[4:0], TA[4:0], and DA[4:0] must be correct for the data-check and PEC features to function as intended. This bitfield is unaffected in the event of a software POR (SWPOR) request by the host.</p>
TA	9:5	<p>Top-Device Address in a UART Chain: Address of the device connected to the top of the daisy-chain. If the host sends an initial address in the HELLOALL command through the UART DOWN path (assign/decrement), then the host must write that top address (as well as the expected bottom address) to all devices in the daisy-chain with a WRITEALL command to this bitfield. READALL commands and Alert Packets require that BA[4:0], TA[4:0], and DA[4:0] must be correct for the data-check and PEC features to function as intended. This bitfield is unaffected in the event of a software POR (SWPOR) request by the host.</p>
DA	4:0	<p>Device Address: Device address written only by the HELLOALL command as it propagates through the daisy-chain. If HELLOALL is issued through the UART Up path, this bitfield is accepted and automatically incremented by each device. If HELLOALL is issued through the UART DOWN path, this bitfield is accepted and automatically decremented by each device. The host must choose an initial (bottom) address 0x00 or greater and ensure the resulting top address not exceed the maximum address of 0x1F during the propagation of the HELLOALL command through the Up path. Likewise, the host must choose an initial (top) address (0x1F or lower) and ensure that the resulting bottom address is 0x00 or greater after propagation of the HELLOALL command through the DOWN path. Writing has no effect, only a HELLOALL command executed while ADDRUNLOCK = 1 updates this content. This bitfield is unaffected in the event of a software POR (SWPOR) request by the host.</p>

STATUS1 (0x02)

STATUS1 is a read-/write-accessible register that relates the current status of the device. STATUS1 also contains summary information on STATUS2, STATUS3, and FMEA registers, and other selected registers, indicating if additional readback checks are required.

BIT	15	14	13	12	11	10	9	8
Field	ALRTSCAN	ALRTRST	ALRT-MSMTCH	ALRTCEL-LOVST	ALRTCEL-LUVST	ALRT-BLKOVST	ALRTBLKU-VST	ALR-TAUXOVST
Reset	0b0	0b1	0b0	0b0	0b0	0b0	0b0	0b0
Access Type	Read Only	Write 0 to Clear, Read	Read Only	Read Only	Read Only	Read Only	Read Only	Read Only
BIT	7	6	5	4	3	2	1	0
Field	ALRTAUXU-VST	–	ALRTPEC	ALRTIN-TRFC	ALRTCAL	ALRTCBAL	ALRT-FMEA2	ALRT-FMEA1
Reset	0b0	–	0b0	0b0	0b0	0b0	0b0	0b0
Access Type	Read Only	–	Read Only	Read Only	Read Only	Read Only	Read Only	Read Only

BITFIELD	BITS	DESCRIPTION
ALRTSCAN	15	<p>Scan-Done Alert: 0 = No measurement requested or measurement in progress (default) 1 = Measurement complete Cleared if SCANCRTL:SCANDONE is removed. Read only.</p>
ALRTRST	14	<p>Reset Alert: Indicates if a power-on-reset (POR) event occurred. UART users should clear this alert after power on and after a successful HELLOALL transaction to detect future resets. SPI users should clear this alert immediately after power on to detect future resets. Cleared only by writing to logic zero. Writing to a logic one has no effect.</p>
ALRTMSMTCH	13	<p>Cell-Voltage-Mismatch Alert: Indicates $V_{MAX} - V_{MIN} > V_{MSMTCH}$ threshold. To aid diagnosis, read MINMAXCELL for detailed information on which channels are involved. Cleared at next acquisition if the condition is false. Read only.</p>
ALRTCELLOVST	12	<p>Cell-Overvoltage Status-Summary Alert: Bit-wise logical OR of ALRTOV[14:1] and ALRTCOMPOV[14:1]. To aid diagnosis, read ALRTSUM for information on whether the ADC, comparator, or both circuits detected the fault. Cleared on next acquisition, if all enabled overvoltage conditions are resolved. Read only.</p>

BITFIELD	BITS	DESCRIPTION
ALRTCELLUVST	11	<p>Cell-Undervoltage Status-Summary Alert: Bit-wise logical OR of ALRTUV[14:1] and ALRTCOMPUV[14:1]. To aid diagnosis, read ALRTSUM for information on whether the ADC, comparator, or both circuits detected the fault. Cleared on next acquisition, if all enabled undervoltage conditions are resolved. Read only.</p>
ALRTBLKOVST	10	<p>Block-Overvoltage Status Alert: Indicates if the latest block-voltage measurement exceeded the threshold set by BLKOVTHSET. Cleared on next Block-voltage acquisition, if condition is resolved. Read only.</p>
ALRTBLKUVST	9	<p>Block-Undervoltage Status Alert: Indicates if the latest block-voltage measurement was below the threshold set by BLKUVTHSET. Cleared on next block-voltage acquisition, if condition is resolved. Read only.</p>
ALRTAUXOVST	8	<p>Auxiliary-Overvoltage (Cold) Status-Summary Alert: Logical OR of ALRTAUXOV[5:0] and ALRTCOMPAUXOV[5:0] auxiliary alerts. To aid diagnosis, read ALRTSUM for information on whether the ADC, comparator, or both circuits detected the fault. Cleared on next acquisition, if all enabled overvoltage conditions are resolved. Read only.</p>
ALRTAUXUVST	7	<p>Auxiliary-Undervoltage (Hot) Status-Summary Alert: Logical OR of ALRTAUXUV[5:0] and ALRTCOMPAUXUV[5:0] auxiliary alerts. To aid diagnosis, read ALRTSUM for information on whether the ADC, comparator, or both circuits detected the fault. Cleared on next acquisition, if all enabled undervoltage conditions are resolved. Read only.</p>
ALRTPEC	5	<p>Packet-Error Check (PEC) Alert: Indicates a received UART/SPI character/transaction contained a PEC/CRC error and was ignored as a result. Logical OR of (ALRTPECUP, ALRTPEC DN, SPICRCERR). Cleared if component alerts are resolved in STATUS2:ALRTPECUP/DN (UART), or STATUS2:ALRTSPI (SPI). See component bitfield descriptions for details. Note: In UARTSEL = 0 (SPI mode), the SPICRCERR bit only appears in the SPI transaction as STAT4 (DO[31]), it does not activate STATUS2:ALRTSPI, though it is cleared by writing STATUS2:ALRTSPI to zero. Read only.</p>

BITFIELD	BITS	DESCRIPTION
ALRTINTRFC	4	<p>Interface-Specific Error Alert: Indicates that an error specific to the selected interface (UART or SPI user interface) has occurred. For UART operation, this is the bitwise OR of ALRTMANUP/DN, ALRTPARUP/DN, ALRTDUALART, and ALRTRJCT. For SPI operation, this is the bitwise OR of ALRTSPI, ALRTSCLKERR, ALRTOSC3, ALRTINTBUS, and ALRTRJCT. ALRTPEC is common to both UART and SPI interfaces and holds a dedicated position in the status registers (assertion of ALRTPEC not does assert ALRTINTRFC). If this alert bit is set, the specific error(s) can be read and cleared using the STATUS2 register.</p>
ALRTCAL	3	<p>Calibration-Fault Alert: Logical OR of all calibration alerts (ALRTCALOSADC, ALRTCALOSR, ALRTCALOSTHRM, ALRTCALGAINP, and ALRTCALGAINR). Cleared if component alerts are resolved in ALRTSUM. See ALRTSUM and ALRTIRQEN for details. Read only. Note: If a calibration error occurs during an automated cell balancing or discharge operation, the operation ends and issues CACTIVE = 11 and ALRTCBCAL, notifying the user of the termination.</p>
ALRTCBAL	2	<p>Cell-Balancing Status Alert: 0 = Cell balancing inactive/normal 1 = Cell balancing complete/fault Logical OR of all enabled/unmasked cell-balancing alerts (ALRTCBTIMEOUT, ALRTCBTEMP, ALRTCBCAL, ALRTCBNTFY, and ALRTCBDONE). Cleared if component alerts are resolved in STATUS3. See STATUS3 and ALRTIRQEN for details. Read only.</p>
ALRTFMEA2	1	<p>FMEA2 Condition Summary Alert: Bit-wise logical OR of FMEA2[15:0]. Read only.</p>
ALRTFMEA1	0	<p>FMEA1 Condition Summary Alert: Bit-wise logical OR of FMEA1[15:0]. Read only.</p>

STATUS2 (0x03)

STATUS2 is a read-/write-accessible register that contains summary information on alerts related to interface and communication faults.

BIT	15	14	13	12	11	10	9	8
Field	ALRTPE-CUP	ALRTP-ECDN	ALRTMAN-UP	ALRT-MANDN	ALRTPA-RUP	ALRT-PARDN	ALRTDU-ALUART	–
Reset	0b0	0b0	0b0	0b0	0b0	0b0	0b0	–
Access Type	Write 0 to Clear, Read	Write 0 to Clear, Read	Write 0 to Clear, Read	Write 0 to Clear, Read	Write 0 to Clear, Read	Write 0 to Clear, Read	Write 0 to Clear, Read	–
BIT	7	6	5	4	3	2	1	0
Field	ALRTSPI	ALRTSCLK-ERR	ALRTOSC3	ALRTINT-BUS	–	–	–	ALRTRJCT
Reset	0b0	0b0	0b0	0b0	–	–	–	0b0
Access Type	Write, Read, Ext	Write, Read, Ext	Write, Read, Ext	Write, Read, Ext	–	–	–	Write 0 to Clear, Read

BITFIELD	BITS	DESCRIPTION
ALRTPECUP	15	<p>UART Up-Interface PEC Alert: Indicates that a character/transaction received by the UART Up interface contained a PEC error and was ignored as a result. Cleared only by writing to logic zero. Writing to a logic one has no effect. Applies only to parts operating using the UART interface (UARTSEL = 1). PEC is not used in SPI mode (SPI CRC checking is reported and managed directly through ALRTPEC and ALRTSPI, respectively).</p>
ALRTPECDN	14	<p>UART Down-Interface PEC Alert: Indicates that a character/transaction received by the UART Down interface contained a PEC error and was ignored as a result. Cleared only by writing to logic zero. Writing to a logic one has no effect. Applies only to parts operating using the dual-UART interface (UARTSEL = 1, UARTCFG = 11); not used in SPI mode.</p>
ALRTMANUP	13	<p>UART Up-Interface Manchester-Encoding Error: Indicates that a character received by the UART Up interface (through RXL) contained a Manchester error. Cleared only by writing to logic zero. Writing to a logic one has no effect. Applies only to parts operating using the UART interface (UARTSEL = 1). Manchester encoding is not used in SPI mode.</p>
ALRTMANDN	12	<p>UART Down-Interface Manchester-Encoding Error: Indicates that a character received by the UART down interface (through RXU) contained a Manchester error. Cleared only by writing to logic zero. Writing to a logic one has no effect. Applies only to parts operating using the dual-UART interface (UARTSEL = 1, UARTCFG = 11). Manchester encoding is not used in SPI mode.</p>

BITFIELD	BITS	DESCRIPTION
ALRTPARUP	11	<p>UART Up-Interface Parity Error: Indicates that a character received by the UART Up interface (through RXL) contained a parity error. Cleared only by writing to logic zero. Writing to a logic one has no effect. Applies only to parts operating using the UART interface (UARTSEL = 1). Parity checking is not used in SPI mode.</p>
ALRTPARDN	10	<p>UART Down-Interface Parity Error: Indicates that a character received by the UART Down interface (through RXU) contained a parity error. Cleared only by writing to logic zero. Writing to a logic one has no effect. Applies only to parts operating using the dual-UART interface (UARTSEL = 1, UARTCFG = 11). Parity checking is not used in SPI mode.</p>
ALRTDUALUART	9	<p>Dual-UART Fault Alert: 0 = No dual-UART fault detected 1 = Invalid dual-UART command received ALRTDUALUART indicates that one or more of the following conditions occurred: A WRITEDEVICE or WRITEALL command sent through a path not configured as host was ignored (only the host path accepts writes). An UPHOST command was issued and ignored on the downstream UART path. A DOWNHOST command was issued and ignored on the upstream UART path. These conditions are checked only when UARTCFG = DUAL (11). Cleared only by writing to logic zero. Writing to a logic one has no effect.</p>
ALRTSPI	7	<p>SPI Error Summary Alert: Indicates that one or more of the following SPI transaction errors have occurred: R/WB != R/WB' (i.e., DI[31] != DI[3], RW_ERR)DI_N[15:0] != 0x0000 in read mode (RW_ERR) transaction timeout (TO_ERR). Specific error-condition breakouts are reported as STAT[4:0] (DO[31:27]) as part of all SPI transactions. All existing SPI CRC_ERR, RW_ERR, and TO_ERR, alerts be cleared by writing this bit to logic zero. Writing to a logic one has no effect. Applies only to parts operating using the SPI interface (UARTSEL = 0). Note: The SPI CRC_ERR condition is reported using the dedicated STATUS1:ALRTPEC bit (read only), but is cleared using this bitfield (i.e., the CRC_ERR condition is not reported in ALRTSPI). To clear ALRTPEC, it is necessary to write ALRTSPI to zero even if it is already zero (if no other SPI errors are reported). SPI clock issues covered by SPI CLK_ERR are broken out, reported, and cleared individually (see ALRTSCLKERR, ALRTOSC3, and ALRTINTBUS for details).</p>

BITFIELD	BITS	DESCRIPTION
ALRTSCLKERR	6	<p>SPI SCLK-Error Alert: Indicates that an SPI transaction was received that was not exactly 32 SCLK cycles in length. This error condition is one of three reported as STAT1 (DO28) as part of all SPI transactions. Cleared by writing this bit to logic zero. Writing to a logic one has no effect. Applies only to parts operating using the SPI interface (UARTSEL = 0).</p>
ALRTOSC3	5	<p>16MHz Oscillator-Fault Alert: Indicates that the 16MHz oscillator frequency is not within $\pm 5\%$ of its expected value when measured against the 32kHz oscillator. The status is updated every two cycles (32kHz). Required/supported only in SPI mode (UARTSEL = 0). While it is possible for the SPI interface to continue to function under drift-alert conditions, it does not function if the 16MHz oscillator is dead or extremely fast/slow. This error condition is one of three reported as STAT1 (DO28) as part of all SPI transactions. Cleared only by writing to logic zero if the condition has been resolved. Writing to a logic one has no effect.</p>
ALRTINTBUS	4	<p>SPI Internal Bus-Transaction Failure: Indicates that an SPI read or write transaction was not correctly passed across the internal memory bus. This can happen if the 16MHz oscillator (or branch) clocking the internal bus is dead, intermittent, or severely out of its specified frequency range. May be accompanied by ALRTOSC1, 2, or 3 alerts. This error condition is one of three reported as STAT1 (DO28) as part of all SPI transactions. Cleared by writing this bit to logic zero. Writing to a logic one has no effect. Applies only to parts operating using the SPI interface (UARTSEL = 0).</p>

BITFIELD	BITS	DESCRIPTION
ALRTRJCT	0	<p>Protected Command-Rejection Alert: 0 = Normal operation 1 = Invalid command rejected during an active scan or cell-balancing operation. ALRTRJCT is issued when an invalid write to a protected register is received during an active/gating scan or cell-balancing operation. The invalid command should be ignored. Cleared only by writing to logic zero. Writing to a logic one has no effect.</p>

STATUS3 (0x04)

STATUS3 is a read/write-accessible register that contains summary information on alerts related to automated cell-balancing operations.

BIT	15	14	13	12	11	10	9	8
Field	ALRTCB-TIMEOUT	ALRTCB-TEMP	ALRTCB-CAL	ALRT-CBNTFY	ALRTCB-DONE	–	–	–
Reset	0b0	0b0	0b0		0b0	–	–	–
Access Type	Write 0 to Clear, Read	Write 0 to Clear, Read	Write 0 to Clear, Read	Write 0 to Clear, Read	Write 0 to Clear, Read	–	–	–
BIT	7	6	5	4	3	2	1	0
Field	–	–	–	–	–	–	–	–
Reset	–	–	–	–	–	–	–	–
Access Type	–	–	–	–	–	–	–	–

BITFIELD	BITS	DESCRIPTION
ALRTCBTIMEOUT	15	<p>Cell-Balancing Timeout Alert: 0 = Cell balancing disabled or in progress 1 = Cell-balancing operation halted due to a timeout fault ALRTCBTIMEOUT is issued when a discharge, or automated cell-balancing operation is halted due to an internal logic fault condition triggering the watchdog timer. This alert is automatically enabled if CBTODIS = 0. Cleared only by writing to logic zero. Writing to a logic one has no effect.</p>
ALRTCBTEMP	14	<p>Cell-Balancing Thermal Alert: 0 = Cell balancing disabled or in progress 1 = Cell-balancing operation halted due to a thermal fault ALRTCBTEMP is issued when a manual, discharge, or automated cell-balancing operation is halted due to a thermal-fault condition. This alert is automatically enabled if CBTEMPEN = 1. Cleared only by writing to logic zero after the automated cell-balancing operation that generated the alert has been completed or otherwise ended. Writing to a logic one has no effect.</p>

BITFIELD	BITS	DESCRIPTION
ALRTCBCAL	13	<p>Cell-Balancing Calibration Alert: 0 = Cell balancing disabled or in progress 1 = Cell-balancing operation halted due to a calibration fault ALRTCBCAL is issued when a discharge, or automated cell-balancing operation is halted due to an embedded calibration fault condition. Cleared only by writing to logic zero after the automated cell-balancing operation that generated the alert has been completed or otherwise ended. Writing to a logic one has no effect.</p>
ALRTCBNTFY	12	<p>Cell-Balancing Notification Alert: 0 = No cell-balancing progression notification present 1 = Cell-balancing progression notification ALRTCBNTFY is periodically issued during discharge and automated cell-balancing operations to confirm normal progression of the operation. This alert is enabled and configured by CBNTFYCFG. Cleared only by writing to logic zero. Writing to a logic one has no effect.</p>
ALRTCBDONE	11	<p>Cell-Balancing-Complete Alert: 0 = Cell balancing disabled or in progress 1 = Cell-balancing operation complete ALRTCBDONE is issued when a manual, discharge, or automated cell-balancing operation completes due to a normal timed or undervoltage exit condition. Cleared only by writing to logic zero. Writing to a logic one has no effect.</p>

FMEA1 (0x05)

FMEA1 is a read-/write-accessible register that relates current information on possible fault conditions.

BIT	15	14	13	12	11	10	9	8
Field	ALRTOSC1	ALRTOSC2	ALRTCOM-MSEU1	ALRTCOM-MSEL1	ALRTCOM-MSEU2	ALRTCOM-MSEL2	ALRTVD-DL3	ALRTVD-DL2
Reset	0b0	0b0	0b0	0b0	0b0	0b0	0b0	0b0
Access Type	Write 0 to Clear, Read	Write 0 to Clear, Read	Read Only	Read Only	Read Only	Read Only	Write 0 to Clear, Read	Write 0 to Clear, Read
BIT	7	6	5	4	3	2	1	0
Field	ALRTVD-DL1	ALRT-GNDL3	ALRT-GNDL2	ALRT-GNDL1	ALRTHVUV	ALRTHVH-DRM	ALRTHVOV	ALRTBALS-WSUM
Reset	0b0	0b0	0b0	0b0	0b0	0b0	0b0	0b0
Access Type	Write 0 to Clear, Read	Write 0 to Clear, Read	Write 0 to Clear, Read	Write 0 to Clear, Read	Write 0 to Clear, Read	Write 0 to Clear, Read	Write 0 to Clear, Read	Write, Read, Ext

BITFIELD	BITS	DESCRIPTION
ALRTOSC1	15	32kHz Oscillator-Fault Alert: Indicates that the 32kHz frequency is not within $\pm 5\%$ of its expected value when measured against the 16MHz oscillator. The status is updated every two cycles (32kHz). Cleared only by writing to logic zero if the condition has been resolved. Writing to a logic one has no effect.
ALRTOSC2	14	32kHz Oscillator-Fault Alert (Redundant): Identical to ALRTOSC1 (redundant alert with independent latch). Cleared only by writing to logic zero if the condition has been resolved. Writing to a logic one has no effect.
ALRTCOMMSEU1	13	UART Upper-Port Single-Ended Alert: Indicates that the UART has placed the upper-port receiver in single-ended mode based on the first preamble received after POR. This bit is not set until the ALRTRST bit is cleared. Read only.
ALRTCOMMSEL1	12	UART Lower-Port Single-Ended Alert: Indicates that the UART has placed the lower-port receiver in single-ended mode based on the first preamble received after POR. This bit is not set until the ALRTRST bit is cleared. Read only.
ALRTCOMMSEU2	11	UART Upper-Port Single-Ended Redundant Alert: Same as ALRTCOMMSEU1 (redundant alert) except that it sets before ALRTRST is cleared. Read only.
ALRTCOMMSEL2	10	UART Lower-Port Single-Ended Redundant Alert: Same as ALRTCOMMSEL1 (redundant alert) except that it sets before ALRTRST is cleared. Read only.
ALRTVDDL3	9	VDDL3 Fault Alert: Indicates $V_{DDL3} < V_{VDDL_OC}$. This bit is not set until the ALRTRST bit is cleared. Cleared only by writing to logic zero if condition is resolved. Writing to a logic one has no effect.
ALRTVDDL2	8	VDDL2 Fault Alert: Indicates $V_{DDL2} < V_{VDDL_OC}$. This bit is not set until the ALRTRST bit is cleared. Cleared only by writing to logic zero if condition is resolved. Writing to a logic one has no effect.
ALRTVDDL1	7	VDDL1 Fault Alert: Indicates $V_{DDL1} < V_{VDDL_OC}$. This bit is not set until the ALRTRST bit is cleared. Cleared only by writing to logic zero if condition is resolved. Writing to a logic one has no effect.
ALRTGNDL3	6	GNDL3 Fault Alert: Indicates an open-circuit on the GNDL3 pin. This bit is not set until the ALRTRST bit is cleared. Cleared only by writing to logic zero. Writing to a logic one has no effect.

BITFIELD	BITS	DESCRIPTION
ALRTGNDL2	5	GNDL2 Fault Alert: Indicates an open-circuit on the GNDL2 pin. This bit is not set until the ALRTRST bit is cleared. Cleared only by writing to logic zero. Writing to a logic one has no effect.
ALRTGNDL1	4	GNDL1 Fault Alert: Indicates an open-circuit on the GNDL1 pin. This bit is not set until the ALRTRST bit is cleared. Cleared only by writing to logic zero. Writing to a logic one has no effect.
ALRTHVUV	3	HV-Undervoltage Fault Alert: Indicates $V_{HV} < V_{HVUV}$. This bit is not set until the ALRTRST bit is cleared. Cleared only by writing to logic zero. Writing to a logic one has no effect.
ALRTHVHDM	2	HV-Headroom Fault Alert: Indicates that $V_{HV} - V_{TOPCELL1/2}$ was too low during the acquisition for an accurate measurement. Checked only during measurement activity. Cleared only by writing to logic zero. Writing to a logic one has no effect.
ALRTHVOV	1	HV-Overvoltage Fault Alert: Indicates that $V_{HV} - V_{DCIN} > V_{HVOV}$. This bit is not set until the ALRTRST bit is cleared. Cleared only by writing to logic zero. Writing to a logic one has no effect.
ALRTBALSSUM	0	Balance-Switch Fault-Alert Summary: Bit-wise logical OR of ALRTBALSW[13:0]. Updated at the end of a BALSWDIAG scan. Cleared if all enabled ALRTBALSW alerts are resolved or by writing to logic zero. Writing to a logic one has no effect.

FMEA2 (0x06)

FMEA1 is a read-/write-accessible register that relates current information on possible fault conditions.

BIT	15	14	13	12	11	10	9	8
Field	ALRTUSER	ALRTDCIN-MUX	ALRTAUX-PRTCTSUM	ALRTTEMP	ALRTSCAN-TIMEOUT	–	–	–
Reset	0b0	0b0	0b0	0b0	0b0	–	–	–
Access Type	Write, Read	Write 0 to Clear, Read	Read Only	Write 0 to Clear, Read	Read Only	–	–	–
BIT	7	6	5	4	3	2	1	0
Field	–	–	–	–	ALRTAD-CZS	ALRTAD-CFS	ALRTCOM-PACCOV	ALRTCOM-PACCUV
Reset	–	–	–	–	0b0	0b0	0b0	0b0

Access Type	–	–	–	–	Write 0 to Clear, Read	Write 0 to Clear, Read	Write 0 to Clear, Read	Write 0 to Clear, Read
BITFIELD	BITS	DESCRIPTION						
ALRTUSER	15	<p>User-Defined Alert (Diagnostic): Used to test the alert interface. Asserted by writing to logic one. The resulting alert is relayed through the alert interface/UART DCByte/SPI ALERT bit and can be read back using the FMEA2 command. Cleared by writing to logic zero (default).</p>						
ALRTDCINMUX	14	<p>DCIN MUX-Fault Alert: 0 = No DCINMUX fault detected (default) 1 = DCINMUX fault detected A high condition indicates the enabled DCINMUX is not functioning properly in a Flex Pack application. Connections will be made by diodes; performance may be impacted and/or other related faults issued. This alert is enabled if the DCINMUX is enabled (FLXPACKEN = 1), after STATUS1:ALRTRST has been cleared. The PACKCFG register makes selections on which SW[n] input is used for the DCIN supply and which C[n] is used for the VBLK measurements in Flex Pack applications. Cleared only by writing to logic zero if condition has been resolved. Writing to a logic one has no effect.</p>						
ALRTAUXPRTCTSUM	13	<p>Auxiliary-Protection Fault-Alert Summary: Logical OR of all enabled ALRTAUXPRTCT bits, indicating one or more AUXINn inputs is in a fault mode with input protection engaged. These alerts are enabled for all AUXn/GPIOn pins currently configured as AUXINn inputs. This bit is only cleared when the ALRTAUXPRTCT register is cleared (see the ALRTAUXPRTCT register for specific details). Read only.</p>						
ALRTTEMP	12	<p>Die Overtemperature-Fault Alert: Indicates that $T_{DIE} > 115^{\circ}\text{C}$ (120°C typical). Cleared only by writing to logic zero. Writing to a logic one has no effect. If a thermal alert occurs during an automated cell-balancing or discharge operation, the operation ends and issues CBACTIVE = 11 and ALRTCBTEMP, notifying the user of the termination.</p>						
ALRTSCANTIMEOUT	11	<p>Scan-Timeout Alert: 0 = Scan not requested or progressing normally (default) 1 = Scan operation halted due to timeout fault ALRTSCANTIMEOUT is a copy of SCANTIMEOUT. This alert is automatically enabled if SCANTODIS = 0. Cleared only by writing SCANCTRL:SCANTIMEOUT to zero. Read only.</p>						

BITFIELD	BITS	DESCRIPTION
ALRTADCZS	3	<p>ADC Zero-Scale BIST Alert: 0 = ADC zero-scale BIST passed 1 = ADC zero-scale BIST failed Reports the result of the ADC zero-scale BIST measurement performed during the last acquisition. Tests the SAR ADC DAC, comparator, and logic components. Enabled using ADCZSFSEN. Cleared only by writing to logic zero. Writing to a logic one has no effect. Note: If detailed results are desired, use the zero-scale ADC detailed diagnostic.</p>
ALRTADCFS	2	<p>ADC Full-Scale BIST Alert: 0 = ADC full-scale BIST passed 1 = ADC full-scale BIST failed Reports the result of the ADC full-scale BIST measurement performed during the last acquisition. Tests the SAR ADC DAC, comparator, and logic components. Enabled using ADCZSFSEN. Cleared only by writing to logic zero. Writing to a logic one has no effect. Note: If detailed results are desired, use the full-scale ADC diagnostic.</p>
ALRTCOMPACCOV	1	<p>End-of-Sequence Comparator-Accuracy Diagnostic Overvoltage Alert: 0 = Comparator accuracy OV test passed 1 = Comparator accuracy OV test failed Result of the end-of-sequence comparator-accuracy overvoltage diagnostic if enabled (SCANCFG = 001 or 010, and COMPACCEN = 1). Cleared only by writing to logic zero. Writing to a logic one has no effect.</p>
ALRTCOMPACCUV	0	<p>End-of-Sequence Comparator-Accuracy Diagnostic Undervoltage Alert: 0 = Comparator accuracy UV test passed 1 = Comparator accuracy UV test failed Result of the end-of-sequence comparator-accuracy undervoltage diagnostic if enabled (SCANCFG = 001 or 010, and COMPACCEN = 1). Cleared only by writing to logic zero. Writing to a logic one has no effect.</p>

ALRTSUM (0x07)

ALRTSUM is a read-accessible register that relates added detailed information on the current status of the device, breaking out several summary bits in STATUS1.

BIT	15	14	13	12	11	10	9	8
Field	ALRTAD-COVST	ALRTCOM-POVST	ALRTAD-CUVST	ALRTCOM-PUVST	ALRTAD-CAUXOVST	ALRTCOM-PAUXOVST	ALRTAD-CAUXUVST	ALRTCOM-PAUXUVST
Reset	0b0	0b0	0b0	0b0	0b0	0b0	0b0	0b0
Access Type	Read Only	Read Only	Read Only	Read Only	Read Only	Read Only	Read Only	Read Only
BIT	7	6	5	4	3	2	1	0
Field	-	-	-	ALRTCALO-SADC	ALRT-CALOSR	ALRTCALO-STHRM	ALRTCAL-GAINP	ALRTCAL-GAINR

Reset	–	–	–	0b0	0b0	0b0	0b0	0b0
Access Type	–	–	–	Read Only	Read Only	Read Only	Read Only	Read Only

BITFIELD	BITS	DESCRIPTION
ALRTADCOVST	15	Cell ADC-Overvoltage-Alert Status Summary: Bit-wise logical OR of ALRTOV[14:1], based on ADC measurements. Cleared on next acquisition; if all enabled, overvoltage conditions are resolved. Read only.
ALRTCOMPOVST	14	Comparator Cell-Overvoltage-Alert Status Summary: Bit-wise logical OR of ALRTCOMPOV[14:1], based on redundant comparator monitoring. Cleared on next acquisition, if all enabled overvoltage conditions are resolved. Read only.
ALRTADCUVST	13	Cell ADC-Undervoltage-Alert Status Summary: Bit-wise logical OR of ALRTUV[14:1], based on ADC measurements. Cleared on next acquisition, if all enabled undervoltage conditions are resolved. Read only.
ALRTCOMPUVST	12	Comparator Cell-Undervoltage-Alert Status Summary: Bit-wise logical OR of ALRTCOMPUV[14:1], based on redundant comparator monitoring. Cleared on next acquisition, if all enabled undervoltage conditions are resolved. Read only.
ALRTADCAUXOVST	11	Auxiliary ADC-Overvoltage (Cold)-Alert Status Summary: Logical OR of ALRTAUXOV[5:0], based on ADC measurements. Cleared on next acquisition, if all enabled overvoltage conditions are resolved. Read only.
ALRTCOMPAUXOVST	10	Comparator Auxiliary-Overvoltage (Cold)-Alert Status Summary: Logical OR of ALRTCOMPAUXOV[5:0], based on redundant comparator monitoring. Cleared on next acquisition, if all enabled overvoltage conditions are resolved. Read only.
ALRTADCAUXUVST	9	Auxiliary ADC-Undervoltage (Hot) Alert: Logical OR of ALRTAUXUV[5:0], based on ADC measurements. Cleared on next acquisition, if all enabled undervoltage conditions are resolved. Read only.
ALRTCOMPAUXUVST	8	Comparator Auxiliary-Undervoltage (Hot)-Alert Status Summary: Logical OR of ALRTCOMPAUXUV[5:0], based on redundant comparator monitoring. Cleared on next acquisition, if all enabled undervoltage conditions are resolved. Read only.
ALRTCALOSADC	4	ADC Offset-Calibration Alert: 0 = ADC offset calibration valid 1 = ADC offset calibration fault ALRTCALOSADC indicates the ADC offset-calibration operation returned a result outside expected boundaries. Cleared when a later calibration operation or write to CALOSADC returns an expected result. Read only.

BITFIELD	BITS	DESCRIPTION
ALRTCALOSR	3	<p>Ramp LSA + ADC Offset-Calibration Alert: 0 = LSA + ADC offset calibration valid 1 = LSA + ADC offset calibration fault ALRTCALOSR indicates the LSA + ADC offset-calibration operation returned a result outside expected boundaries. Cleared when a later calibration operation or write to CALOSR returns an expected result. Read only.</p>
ALRTCALOSTHRM	2	<p>ADC Ratiometric Offset-Calibration Alert: 0 = Ratiometric ADC offset calibration valid 1 = Ratiometric ADC offset calibration fault ALRTCALOSTHRM indicates the ratiometric ADC offset-calibration operation returned a result outside expected boundaries. Cleared when a later calibration operation or write to CALOSTHRM returns an expected result. Read only.</p>
ALRTCALGAINP	1	<p>Pyramid Gain-Calibration Alert: 0 = Pyramid gain calibration valid 1 = Pyramid calibration fault ALRTCALGAINP indicates the gain-calibration operation returned a result outside expected boundaries. Cleared when a later calibration operation or write to CALGAINP returns an expected result. Read only.</p>
ALRTCALGAINR	0	<p>Ramp Gain-Calibration Alert: 0 = Ramp gain-calibration valid 1 = Ramp-calibration fault ALRTCALGAINR indicates the gain-calibration operation returned a result outside expected boundaries. Cleared when a later calibration operation or write to CALGAINR returns an expected result. Read only.</p>

ALRTOVCELL (0x08)

ALRTOVCELL is a read-accessible register that relates current information on cell overvoltage-fault alerts based on ADC measurements.

BIT	15	14	13	12	11	10	9	8
Field	–	–	ALRTOV[14:9]					
Reset	–	–	0x0000					
Access Type	–	–	Read Only					
BIT	7	6	5	4	3	2	1	0
Field	ALRTOV[8:1]							
Reset	0x0000							
Access Type	Read Only							

BITFIELD	BITS	DESCRIPTION
ALRTOV	13:0	Cell Overvoltage-Fault Alert: ALRTOV[n] indicates $V_{CELLN} > V_{OV}$ (OVTHSET threshold for POLARITY = 0, BIPOVTHSET for POLARITY = 1); evaluated/enabled if OVALRTEN[n] = 1. Cleared on next acquisition, if the overvoltage condition is resolved. Read only.

ALRTUVCELL (0x09)

ALRTOVCELL is a read-accessible register that relates current information on cell undervoltage-fault alerts based on ADC measurements.

BIT	15	14	13	12	11	10	9	8
Field	–	–	ALRTUV[14:9]					
Reset	–	–	0x0000					
Access Type	–	–	Read Only					
BIT	7	6	5	4	3	2	1	0
Field	ALRTUV[8:1]							
Reset	0x0000							
Access Type	Read Only							

BITFIELD	BITS	DESCRIPTION
ALRTUV	13:0	Cell Undervoltage-Fault Alert: ALRTOV[n] indicates $V_{CELLN} < V_{UV}$ (UVTHSET threshold for POLARITY = 0, BIPUVTHSET for POLARITY = 1); evaluated/enabled if UVALRTEN[n] = 1. Cleared on next acquisition if the undervoltage condition is resolved. Read only.

MINMAXCELL (0x0A)

MINMAX is a read-accessible register that relates the cell locations with the highest and lowest values measured.

BIT	15	14	13	12	11	10	9	8
Field	–	–	–	–	MAXCELL[3:0]			
Reset	–	–	–	–	0x0			
Access Type	–	–	–	–	Read Only			
BIT	7	6	5	4	3	2	1	0
Field	–	–	–	–	MINCELL[3:0]			
Reset	–	–	–	–	0x0			
Access Type	–	–	–	–	Read Only			

BITFIELD	BITS	DESCRIPTION
MAXCELL	11:8	<p>Maximum-Voltage Cell: Cell number [14:1] of the maximum voltage enabled/observed (for all CELLENn = 1) in the last scan (SCAN = 1) based on ALU/IIR data as selected by RDFILT. This bitfield is not updated for data requests made with SCAN = 0. If multiple cells have the same maximum value, this field contains the lowest cell number reporting that result.</p> <p>Note: This operation works on unipolar or bipolar measurement sets, as selected by MINMAXPOL. If MINMAXPOL is set so no measurements in the scan meet the criteria (e.g., MINMAXPOL = 1 (bipolar), but POLARITY[14:1] = 0000h), a result of Fh is returned (indicating no valid result was found). Read only.</p>
MINCELL	3:0	<p>Minimum-Voltage Cell: Cell number [14:1] of the minimum-cell voltage enabled/observed (for all CELLENn = 1) in the last scan (SCAN = 1) based on ALU/IIR data as selected by RDFILT. This bitfield is not updated for data requests made with SCAN = 0. If multiple cells have the same minimum value, this field contains the lowest cell number reporting that result.</p> <p>Note: This operation works on unipolar or bipolar measurement sets, as selected by MINMAXPOL. If MINMAXPOL is set so no measurements in the scan meet the criteria (e.g., MINMAXPOL = 1 (bipolar), but POLARITY[14:1] = 0000h), a result of Fh is returned (indicating no valid result was found). Read only.</p>

ALRTAUXPRTCTREG (0x0B)

ALRTAUXPRTCT is a read-accessible register that relates current information on auxiliary input-protection fault alerts.

BIT	15	14	13	12	11	10	9	8
Field	–	–	–	–	–	–	–	–
Reset	–	–	–	–	–	–	–	–
Access Type	–	–	–	–	–	–	–	–

BIT	7	6	5	4	3	2	1	0
Field	–	–	ALRTAUXPRTCT[5:4]		ALRTAUXPRTCT[3:0]			
Reset	–	–	0x00		0x00			
Access Type	–	–	Read Only		Read Only			

BITFIELD	BITS	DESCRIPTION
----------	------	-------------

ALRTAUXPRTCT	5:4	<p>Auxiliary-Protection Fault Alert: ALRTAUXPRTCT[n] indicates $V_{AUXINn} > V_{AA}$; the alert is evaluated/enabled on each AUXn/GPIOn pin configured as an auxiliary input (see AUXGPIOCFG). Once the fault condition is detected on a pin, the AUXINn input switch is disabled to protect internal circuitry. AUXINn measurements and alerts for that pin will be invalid until proper operating conditions are restored. Cleared only if the condition is resolved upon a retry, or if the affected pin is no longer configured as an auxiliary input (disabling the protection circuit). To retry auxiliary operation and clear the fault condition, rewrite the desired configuration to the AUXGPIOCFG register (it is not necessary to toggle the configuration). Read only.</p>
ALRTAUXPRTCT	3:0	<p>Auxiliary-Protection Fault Alert: ALRTAUXPRTCT[n] indicates $V_{AUX[n]} > V_{AA}$; the alert is evaluated/enabled on each AUXn/GPIOn pin configured as an auxiliary input (see AUXGPIOCFG). Once the fault condition is detected on a pin, the AUX[n] input switch is disabled to protect internal circuitry. AUX[n] measurements and alerts for that pin will be invalid until proper operating conditions are restored. Cleared only if the condition is resolved upon a retry, or if the affected pin is no longer configured as an auxiliary input (disabling the protection circuit). To retry auxiliary operation and clear the fault condition, rewrite the desired configuration to the AUXGPIOCFG register (it is not necessary to toggle the configuration). Read only.</p>

ALRTAUXOVREG (0x0C)

ALRTAUXOV is a read-accessible register that relates current information on auxiliary-overvoltage (cold)-fault alerts.

BIT	15	14	13	12	11	10	9	8
Field	–	–	–	–	–	–	–	–
Reset	–	–	–	–	–	–	–	–
Access Type	–	–	–	–	–	–	–	–
BIT	7	6	5	4	3	2	1	0
Field	–	–	ALRTAUXOV[5:4]		ALRTAUXOV[3:0]			
Reset	–	–	0x0		0x0			
Access Type	–	–	Read Only		Read Only			
BITFIELD	BITS		DESCRIPTION					

ALRTAUXOV	5:4	<p>Auxiliary-Overvoltage (Cold)-Fault Alert: ALRTAUXOV[n] indicates $V_{AUXINn} > V_{AUXOVTHSET}$; evaluated/enabled if $AUXOVALRTEN[n] = 1$. Cleared on next acquisition, if the overvoltage condition is resolved. Read only.</p>
ALRTAUXOV	3:0	<p>AuxiliaryOvervoltage (Cold)-Fault Alert: ALRTAUXOV[n] indicates $V_{AUXINn} > V_{AUXOVTHSET}$; evaluated/enabled if $AUXOVALRTEN[n] = 1$. Cleared on next acquisition, if the overvoltage condition is resolved. Read only.</p>

ALRTAUXUVREG (0x0D)

ALRTAUXUV is a read-accessible register that relates current information on auxiliary undervoltage fault (hot) alerts.

BIT	15	14	13	12	11	10	9	8
Field	–	–	–	–	–	–	–	–
Reset	–	–	–	–	–	–	–	–
Access Type	–	–	–	–	–	–	–	–
BIT	7	6	5	4	3	2	1	0
Field	–	–	ALRTAUXUV[5:4]		ALRTAUXUV[3:0]			
Reset	–	–	0x0		0x0			
Access Type	–	–	Read Only		Read Only			

BITFIELD	BITS	DESCRIPTION
ALRTAUXUV	5:4	<p>Auxiliary-Undervoltage (Hot)-Fault Alert: ALRTAUXUV[n] indicates $V_{AUXINn} < V_{AUXUVTHSET}$; evaluated/enabled if $AUXUVALRTEN[n] = 1$. Cleared on next acquisition, if the undervoltage condition is resolved. Read only.</p>
ALRTAUXUV	3:0	<p>Auxiliary-Undervoltage (Hot)-Fault Alert: ALRTAUXUV[n] indicates $V_{AUXINn} < V_{AUXUVTHSET}$; evaluated/enabled if $AUXUVALRTEN[n] = 1$. Cleared on next acquisition, if the undervoltage condition is resolved. Read only..</p>

ALRTCOMPOVREG (0x0E)

ALRTCOMPOV is a read-accessible register that relates current information on cell overvoltage-fault alerts based on the redundant comparator.

BIT	15	14	13	12	11	10	9	8
Field	–	–	ALRTCOMPOV[14:9]					
Reset	–	–	0x0000					
Access Type	–	–	Read Only					
BIT	7	6	5	4	3	2	1	0
Field	ALRTCOMPOV[8:1]							
Reset	0x0000							
Access Type	Read Only							

BITFIELD	BITS	DESCRIPTION
ALRTCOMPOV	13:0	Cell Overvoltage-Fault Comparator Alert: ALRTCOMPOV[n] indicates $V_{CELL[n]} > V_{COMPOVTH}$ (comparator overvoltage threshold); evaluated/enabled if OVALRTEN[n] = 1. Cleared on next comparator acquisition, if the overvoltage condition is resolved. Read only.

ALRTCOMPUVREG (0x0F)

ALRTCOMPUV is a read-accessible register that relates current information on cell undervoltage-fault alerts based on the redundant comparator.

BIT	15	14	13	12	11	10	9	8
Field	–	–	ALRTCOMPUV[14:9]					
Reset	–	–	0x0000					
Access Type	–	–	Read Only					
BIT	7	6	5	4	3	2	1	0
Field	ALRTCOMPUV[8:1]							
Reset	0x0000							
Access Type	Read Only							

BITFIELD	BITS	DESCRIPTION
ALRTCOMPUV	13:0	Cell Undervoltage-Fault Comparator Alert: ALRTCOMPUV[n] indicates $V_{CELL[n]} < V_{COMPUVTH}$ (comparator undervoltage threshold); evaluated/enabled if UVALRTEN[n] = 1. Cleared on next comparator acquisition, if the undervoltage condition is resolved. Read only.

ALRTCOMPAUXOVREG (0x10)

ALRTCOMPAUXOV is a read-accessible register that relates current information on auxiliary overvoltage-fault (cold) alerts based on the redundant comparator.

BIT	15	14	13	12	11	10	9	8
Field	–	–	–	–	–	–	–	–
Reset	–	–	–	–	–	–	–	–
Access Type	–	–	–	–	–	–	–	–
BIT	7	6	5	4	3	2	1	0
Field	–	–	ALRTCOMPAUXOV[5:4]		ALRTCOMPAUXOV[3:0]			
Reset	–	–	0x0		0x0			
Access Type	–	–	Read Only		Read Only			

BITFIELD	BITS	DESCRIPTION
ALRTCOMPAUXOV	5:4	Auxiliary Overvoltage (Cold) Fault Comparator Alert: ALRTCOMPAUXOV[n] indicates $V_{AUXINn} > V_{COMPOVTH}$ (comparator overvoltage threshold, cold); evaluated/enabled if AUXOVALRTEN[n] = 1. Cleared on next comparator acquisition, if the overvoltage condition is resolved. Read only.
ALRTCOMPAUXOV	3:0	Auxiliary Overvoltage (Cold) Fault Comparator Alert: ALRTCOMPAUXOV[n] indicates $V_{AUXINn} > V_{COMPOVTH}$ (comparator overvoltage threshold, cold); evaluated/enabled if AUXOVALRTEN[n] = 1. Cleared on next comparator acquisition, if the overvoltage condition is resolved. Read only.

ALRTCOMPAUXUVREG (0x11)

ALRTCOMPAUXUV is a read-accessible register that relates current information on auxiliary undervoltage-fault (hot) alerts based on the redundant comparator.

BIT	15	14	13	12	11	10	9	8
Field	–	–	–	–	–	–	–	–
Reset	–	–	–	–	–	–	–	–
Access Type	–	–	–	–	–	–	–	–
BIT	7	6	5	4	3	2	1	0
Field	–	–	ALRTCOMPAUXUV[5:4]		ALRTCOMPAUXUV[3:0]			
Reset	–	–	0x0		0x0			
Access Type	–	–	Read Only		Read Only			

BITFIELD	BITS	DESCRIPTION
ALRTCOMPAUXUV	5:4	Auxiliary Undervoltage (Hot)-Fault Comparator Alert: ALRTCOMPAUXUV[n] indicates $V_{AUXINn} < V_{COMPUVTH}$ (comparator undervoltage threshold, hot); evaluated/enabled if AUXUVALRTEN[n] = 1. Cleared on next acquisition, if the undervoltage condition is resolved. Read only.
ALRTCOMPAUXUV	3:0	Auxiliary Undervoltage (Hot)-Fault Comparator Alert: ALRTCOMPAUXUV[n] indicates $V_{AUXINn} < V_{COMPUVTH}$ (comparator undervoltage threshold, hot); evaluated/enabled if AUXUVALRTEN[n] = 1. Cleared on next acquisition, if the undervoltage condition is resolved. Read only.

ALRTBALSWREG (0x12)

ALRTBALSW is a read-accessible register that relates current summary information on balance-switch fault alerts.

BIT	15	14	13	12	11	10	9	8
Field	–	–	ALRTBALSW[13:8]					
Reset	–	–	0x0000					
Access Type	–	–	Read Only					
BIT	7	6	5	4	3	2	1	0
Field	ALRTBALSW[7:0]							
Reset	0x0000							
Access Type	Read Only							

BITFIELD	BITS	DESCRIPTION
ALRTBALSW	13:0	<p>Balance-Switch Fault Alert: ALRTBALSW[n] indicates the corresponding measurement result fails the threshold specified by the balance-switch diagnostic modes (SCANCFG = 100 through 111). Testing and faults above the TOPCELL1/2 position are automatically masked out of this register (see PACKCFG:TOPCELL1&2 for complete details). Cleared on next acquisition if the condition is resolved. Read only.</p>

SWACTION (0x13)

SWACTION is a read-/write-accessible register that contains bits allowing software exit and reset requests. These requests are not recommended for general use, but may be of use in case of error.

BIT	15	14	13	12	11	10	9	8
Field	–	–	–	–	–	–	–	–
Reset	–	–	–	–	–	–	–	–
Access Type	–	–	–	–	–	–	–	–
BIT	7	6	5	4	3	2	1	0
Field	–	–	–	–	–	–	–	SWPOR
Reset	–	–	–	–	–	–	–	0b0
Access Type	–	–	–	–	–	–	–	Write, Read, Pulse

BITFIELD	BITS	DESCRIPTION
SWPOR	0	Software POR Request: 0 = Normal operation (default, no effect) 1 = Initiates software POR event Always reads logic zero.

DEVCFG1 (0x14)

DEVCFG1 is a read-/write-accessible register that governs the configuration of the device-interface operation.

BIT	15	14	13	12	11	10	9	8
Field	UARTCFG[1:0]		TXIDLE-HIZ	TXLIDLE-HIZ	ADAPTTXEN[1:0]		ALIVECNT-EN	UARTHOST
Reset	0b11		0b0	0b0	0b00		0b0	0b1
Access Type	Write, Read, Ext		Write, Read, Ext	Write, Read, Ext	Write, Read, Ext		Write, Read, Ext	Read Only
BIT	7	6	5	4	3	2	1	0
Field	SFTYCSB	SFTYSCLK	SFTYS DI	SPIDRVINT	DEVCF-G1RSRV	NOPEC	ALERTEN	DBLBUFEN
Reset	0b0	0b0	0b0	0b0	0b0	0b0	0b0	0b0
Access Type	Write, Read, Ext	Write, Read, Ext	Write, Read, Ext	Write, Read, Ext	Write, Read	Write, Read, Ext	Write, Read, Ext	Write, Read

BITFIELD	BITS	DESCRIPTION
UARTCFG	15:14	<p>UART Interface Configuration: 00 = Single-UART interface with external loopback 01 = Single-UART interface with internal loopback 10 = Single-UART interface with differential-alert interface 11 = Dual-UART Interface (default)</p> <p>Single-UART options with Loopback (modes 0x): The UART Up path is used for read and write commands and the down path is used as a return (pass-through) path. If an internal loopback path is desired, the internal shunt should only be engaged on the last device in the chain using mode 01. Alert interface is single-ended (using the ALERTIN and ALERTOUT pins) since the down path is engaged for UART communications.</p> <p>Single-UART with Differential Alert Interface (mode 10): The UART Up path is used for read and write commands with a direct wire return path from the last device in the chain to the μC. The down path is used as a differential-alert path. The single-ended alert-interface path is disabled (the ALERTOUT port idle HIZ, and the ALERTIN port are disabled).</p> <p>Dual-UART interface: Both the up and down interfaces are used for UART communication. Only the host path (selected using UPHOST or DOWNHOST commands, and indicated by HOSTUART) accepts write commands, while both paths can accept read commands. Alert interface is single-ended (using the ALERTIN and ALERTOUT pins) since the down path is engaged for UART communications.</p> <p>For all the above options, the UART Up path uses the RXL→TXU ports, and the UART down path uses the TXL→RXU ports. These bits have no effect if UARTSEL is set low (SPI interface enabled). This bitfield is unaffected in the event of a software POR (SWPOR) request by the host.</p> <p>Note: The device hardware must be preconfigured to support the correct operational mode. The device powers up in the dual-UART mode to ensure any hardware configuration can configure the device. If the incorrect operating mode is configured, the UART master should cease communications (and possibly issue a FORCEPOR) to reset the device to default status through SHDNL assertion.</p>
TXUIDLEHIZ	13	<p>UART Upper-TX-Idle Mode Selection: 0 = TXU drivers idle in logic zero (default) 1 = TXU drivers idle in High-Z</p> <p>Leave in default state for normal operation. This bit has no effect if UARTSEL is set low. This bitfield is unaffected in the event of a software POR (SWPOR) request by the host.</p>
TXLIDLEHIZ	12	<p>UART Lower-TX-Idle Mode Selection: 0 = TXL drivers idle in logic zero (default) 1 = TXL drivers idle in High-Z</p> <p>Leave in default state for normal operation. This bit has no effect if UARTSEL is set low. This bitfield is unaffected in the event of a software POR (SWPOR) request by the host.</p>

BITFIELD	BITS	DESCRIPTION
ADAPTTXEN	11:10	<p>UART Adaptive-Transmission Enable: 00 = Adaptive transmission off (default) 01 = Enable Up path adaptive transmission on TXU 10 = Enable Down path adaptive transmission on TXL 11 = Unsupported (adaptive transmission off) Selections should only be made on device(s) at the end of up/down path(s) that transmit directly to the $\mu\text{C}/\mu\text{P}$. This bit has no effect if UARTSEL is set low. This bitfield is unaffected in the event of a software POR (SWPOR) request by the host.</p>
ALIVECNTEN	9	<p>Enable UART-Interface Alive-Counter: 0 = Do not send alive-counter byte (default) 1 = Enables inclusion of alive-counter byte at end of all write and read packets.</p>
UARTHOST	8	<p>UART Host-Mode Indicator Bit: 0 = UART down path is host 1 = UART Up path is host (default) Indicates which UART path is currently configured as the host. Down-host mode is only accessible if UARTCFG = DUAL (11). The host mode is selected using UPHOST and DOWNHOST commands. This bit has no meaning if UARTSEL is set low, and always reads back one. Read only. This bitfield is unaffected in the event of a software POR (SWPOR) request by the host.</p>
SFTYCSB	7	<p>SPI CSB Safety-Pullup Enable: 0 = CSB pulup disabled (default) 1 = CSB pulup enabled Determines if 100kΩ safety pulup to V_{DDL2} is enabled on the CSB interface input pin. This bit has no effect if UARTSEL is set high. This bitfield is unaffected in the event of a software POR (SWPOR) request by the host.</p>
SFTYSCLK	6	<p>SPI SCLK Safety-Pulldown Enable: 0 = SCLK pulldown disabled (default) 1 = SCLK pulldown enabled Determines if 100kΩ safety pulldown to GND is enabled on the SCLK interface input pin. This bit has no effect if UARTSEL is set high. This bitfield is unaffected in the event of a software POR (SWPOR) request by the host.</p>
SFTYSDI	5	<p>SPI SDI Safety-Pulldown Enable: 0 = SDI pulldown disabled (default) 1 = SDI pulldown enabled Determines if 100kΩ safety pulldown to GND2/3 is enabled on the SDI interface input pin. This bit has no effect if UARTSEL is set high. This bitfield is unaffected in the event of a software POR (SWPOR) request by the host.</p>

BITFIELD	BITS	DESCRIPTION
SPIDRVINT	4	<p>SPI IRQB Output Drive Mode: 0 = Open-drain nMOS (default) 1 = CMOS drive</p> <p>Determines drive mode for SPI IRQB function on ALERTOUT pin. This bit has no effect if UARTSEL is set high.</p> <p>This bitfield is unaffected in the event of a software POR (SWPOR) request by the host.</p>
DEVCFG1RSRV	3	<p>Reserved: Reads back the value written.</p>
NOPEC	2	<p>UART/SPI PEC/CRC Disable: 0 = PEC/CRC enabled (default) 1 = PEC/CRC disabled</p> <p>Determines if packet-error checking is enforced using the UART interface and if cyclic-redundancy checking is enforced using the SPI interface.</p> <p>If this bit is set, the PEC characters should be omitted from the UART packet/command (UARTSEL = 1), and the incoming CRC bits ignored during SPI transactions (UARTSEL = 0).</p>
ALERTEN	1	<p>Alert-Interface Enable: 0 = Alert interface is disabled (default) 1 = Alert interface enabled</p> <p>If disabled, the following conventions apply: If UARTSEL = 1 and UARTCFG = 0x or 11 (single-ended alert), the ALERTOUT port idles Hi-Z and the ALERTIN port is disabled/ignored. If UARTSEL = 1 and UARTCFG = 10 (differential alert), the UART Down path idle as set by TXLIDLEHIZ.</p> <p>If UARTSEL = 0 (SPI), the ALRTOUT pin idles high with drive determined by SPIDRVINT. The ALERTIN pin will be disabled/ignored in SPI mode (no shoot-through current result if the pin is not connected).</p> <p>This bit is unaffected in the event of SWPOR(Soft POR) request by host.</p> <p>If enabled, the following conventions apply: If UARTSEL = 1, the device initiates alerts based on STATUS1 content, as well as passes through any alerts received from/to the daisy-chain. If UARTSEL = 0 (SPI), the device generates active-low alerts based on STATUS1 content with drive determined by SPIDRVINT. The ALERTIN pin will be disabled and ignored in SPI mode (no shoot-through current results if the pin is not connected).</p>
DBLBUFEN	0	<p>Double-Buffer Mode Enable: 0 = Normal operation (default) 1 = Double-buffered operation</p> <p>Enables the double-buffer mode.</p> <p>This mode automatically transfers data from the ALU/IIR to the data registers at the start of the next acquisition, instead of at the end of an acquisition.</p> <p>Note: This mode may be used so the host can start a second acquisition and then begin reading the data from the first acquisition (during the second acquisition). This works even if the first data-read transactions take longer than the second acquisition to complete; simply hold off on a third acquisition until the first acquisition's data is retrieved. Launching a third acquisition moves the data from the second acquisition to the data registers for readback during the third acquisition, and so forth.</p>

DEVCFG2 (0x15)

DEVCFG2 is a read-/write-accessible register that governs the configuration of the device filtering, several top-level diagnostic modes, and timeout monitors.

BIT	15	14	13	12	11	10	9	8
Field	IIRFC[2:0]			–	DEVCFG2RSRV[3:0]			
Reset	0b010			–	0b0000			
Access Type	Write, Read			–	Write, Read			
BIT	7	6	5	4	3	2	1	0
Field	–	HVCPDIS	FORCE-POR	ALERTDCT-STEN	–	SPITODIS	SCANTODIS	CBTODIS
Reset	–	0b0	0b0	0b0	–	0b0	0b0	0b0
Access Type	–	Write, Read	Write, Read	Write, Read	–	Write, Read	Write, Read	Write, Read

BITFIELD	BITS	DESCRIPTION
IIRFC	15:13	<p>IIR Filter Coefficient Selection:</p> <p>000 = 0.125 001 = 0.250 010 = 0.375 (default) 011 = 0.500 100 = 0.625 101 = 0.750 110 = 0.875 111 = 1.000 (filter off)</p> <p>This setting determines the weight of the current measurement result vs. the previously accumulated results in the IIR filter. A setting of 1.0 effectively disables the filter.</p>
DEVCFG2RSRV	11:8	<p>Reserved: Reads back the value written.</p>
HVCPDIS	6	<p>HV Charge Pump Disable:</p> <p>0 = Normal Operation (default) 1 = Disable HV Charge Pump</p> <p>Used for ALRTHVUV diagnostic. If the HV charge pump is disabled in normal operation, measurement errors result due to V_{HV} undervoltage condition.</p>
FORCEPOR	5	<p>Force POR Event:</p> <p>0 = Normal Operation (default) 1 = Enables hard POR by pulling down SHDNL internally. If cleared before the POR occurs, the active pulldown on SHDNL be removed.</p> <p>Note: This bit is used to accelerate a complete POR event issued by SHDNL falling. In UART applications, it is possible continued UART activity fight or overcome the SHDNL pulldown. For best results, cease UART communications when using this mode.</p>

BITFIELD	BITS	DESCRIPTION
ALERTDCTSTEN	4	<p>UART Alert DC Diagnostic Test Enable: 0 = UART Alert DC Testing Disabled (Default) 1 = UART Alert DC Testing Enabled</p> <p>Used to place the ALRTOOUT pin in a DC diagnostic mode for use in testing for shorts to GPIO/AUX0.</p> <p>If Enabled while UARTSEL = 1, the ALRTOOUT pin be driven low if an Alert condition is present, and driven high otherwise. ALRTUSER can be written to exercise ALRTOOUT in either direction. Neighboring pins such as AUX/GPIO[0] can be monitored directly or in diagnostic modes to detect a fault.</p> <p>This function works in all UARTCFG modes, including 10 (Differential Alert), that do not normally use the ALRTOOUT pin.</p> <p>This setting has no impact in SPI mode (UARTSEL = 0), the same functionality can be realized using SPIDRVINIT and ALRTUSER.</p>
SPITODIS	2	<p>SPI Time Out Disable: 0 = SPI Time Out Enabled (default) 1 = SPI Time Out Disabled</p> <p>Determines if SPI time out monitor function is enabled. This bit has no effect if UARTSEL is set high.</p>
SCANTODIS	1	<p>Scan Time Out Disable: 0 = Normal Operation (default) 1 = Disables the acquisition watchdog but does not clear the SCANTIMEOUT flag in the SCANCTRL register if it is set.</p>
CBTODIS	0	<p>Cell-Balancing Timeout Disable: 0 = Normal Operation (default) 1 = Disables the cell balancing watchdog but does not clear the ALRTCB-TIMEOUT flag in the STATUS3 register if it was previously set.</p>

AUXGPIOCFG (0x16)

AUXGPIOCFG is a read-/write-accessible register that governs the configuration of the AUX/GPIO multifunction pins.

BIT	15	14	13	12	11	10	9	8
Field	–	–	GPIOEN[5:4]		GPIOEN[3:0]			
Reset	–	–	0x3		0xF			
Access Type	–	–	Write, Read, Ext		Write, Read, Ext			
BIT	7	6	5	4	3	2	1	0
Field	–	–	GPIODIR[5:4]		GPIODIR[3:0]			
Reset	–	–	0x0		0x0			
Access Type	–	–	Write, Read, Ext		Write, Read, Ext			

BITFIELD	BITS	DESCRIPTION
GPIOEN	13:12	<p>Digital GPIO Mode Enable: 0 = Analog Input (AUX) Mode (High-Z) 1 = Digital GPIO Mode (default)</p> <p>GPIOEN[n] configures the corresponding AUX/GPIO[n] pin for operation in the selected mode.</p>

BITFIELD	BITS	DESCRIPTION
GPIOEN	11:8	Digital GPIO Mode Enable 0 = Analog Input (AUX) Mode (High-Z) 1 = Digital GPIO Mode (default) GPIOEN[n] configures the corresponding AUX/GPIO[n] pin for operation in the selected mode.
GPIODIR	5:4	Digital GPIO Direction Selection 0 = Digital Input Mode (High-Z, default) 1 = Digital Output Mode GPIODIR[n] configures the direction of the corresponding AUX/GPIO[n] pin. This setting is only applicable if GPIOEN[n] = 1 (Digital GPIO Mode enabled). In digital input mode (GPIOEN = 1 and GPIODIR = 0), a 2MΩ pulldown (R _{GPIO}) be enabled to prevent the GPIO input from floating. In digital output mode (GPIOEN = 1 and GPIODIR = 1), the GPIO input circuitry continue to operate, allowing direct observation of the port status.
GPIODIR	3:0	Digital GPIO Direction Selection 0 = Digital Input Mode (High-Z, default) 1 = Digital Output Mode GPIODIR[n] configures the direction of the corresponding AUX/GPIO[n] pin. This setting is only applicable if GPIOEN[n] = 1 (Digital GPIO Mode enabled). In digital input mode (GPIOEN = 1 and GPIODIR = 0), a 2MΩ pulldown (R _{GPIO}) be enabled to prevent the GPIO input from floating. In digital output mode (GPIOEN = 1 and GPIODIR = 1), the GPIO input circuitry continue to operate, allowing direct observation of the port status.

GPIOCFG (0x17)

GPIO is a read-/write-accessible register that governs the output state of GPIO outputs and reads back the input state of GPIO inputs.

BIT	15	14	13	12	11	10	9	8
Field	–	–	GPIODRV[5:4]		GPIODRV[3:0]			
Reset	–	–	0x0		0b0			
Access Type	–	–	Write, Read, Ext		Write, Read, Ext			
BIT	7	6	5	4	3	2	1	0
Field	–	–	GPIORD[5:4]		GPIORD[3:0]			
Reset	–	–	0x0		0x0			
Access Type	–	–	Read Only		Read Only			

BITFIELD	BITS	DESCRIPTION
GPIODRV	13:12	Digital GPIO Output State 0 = Output Logic Zero (default) 1 = Output Logic One GPIODRV[n] sets the output logic state direction of the corresponding AUX/GPIO[n] pin. This setting is only applicable if GPIOEN[n] = 1 and GPIODIR[n] = 1 (Digital GPIO Output Mode enabled).
GPIODRV	11:8	Digital GPIO Output State 0 = Output Logic Zero (default) 1 = Output Logic One GPIODRV[n] sets the output logic state direction of the corresponding AUX/GPIO[n] pin. This setting is only applicable if GPIOEN[n] = 1 and GPIODIR[n] = 1 (Digital GPIO Output Mode enabled).
GPIORD	5:4	Digital GPIO Input State Indicator 0 = Logic Zero (default) 1 = Logic One GPIORD[n] indicates the current logic state of each active GPIO[n] input buffer. Data is only relevant if GPIOEN[n] = 1 (all Digital GPIO pins are monitored in Input or Output mode), otherwise zero be read back. For UART, the logic state is sampled at the end of the parity bit of the register address byte during a read transaction. For SPI, the logic state is sampled in response to the 9th SCLK rising edge during a read transaction. Read only.
GPIORD	3:0	Digital GPIO Input State Indicator 0 = Logic Zero (default) 1 = Logic One GPIORD[n] indicates the current logic state of each active GPIO[n] input buffer. Data is only relevant if GPIOEN[n] = 1 (all Digital GPIO pins are monitored in Input or Output mode), otherwise zero be read back. For UART, the logic state is sampled at the end of the parity bit of the register address byte during a read transaction. For SPI, the logic state is sampled in response to the 9th SCLK rising edge during a read transaction. Read only.

PACKCFG (0x18)

PACKCFG is a read-/write-accessible register that configures the part such that the top most cell and block used in the application is known. Details of Flex Pack applications are also configured within this register.

BIT	15	14	13	12	11	10	9	8
Field	FLXPCK-EN2	FLXPCK-EN1	FLXPCK-SCAN	–	TOPBLOCK[3:0]			
Reset	0b1	0b1	0b1	–	0xF			
Access Type	Write, Read	Write, Read	Write, Read	–	Write, Read			
BIT	7	6	5	4	3	2	1	0
Field	TOPCELL2[3:0]				TOPCELL1[3:0]			
Reset	0xF				0xF			
Access Type	Write, Read				Write, Read			

BITFIELD	BITS	DESCRIPTION
FLXPCKEN2	15	<p>Flex Pack Enable 2 0 = Flex Pack functions disabled 1 = Flex Pack selection of top cell and top block enabled (default) Indicates the flexible-pack support is engaged (DCINMUX and VBLKMUX), selecting the internal power and block-routing path when the DCIN pin is not supplied externally. This selection is protected by a redundant bitfield. FLXPCKEN1 & FLXPCKEN2 must agree, resulting in a valid internal FLXPCKEN1/2 selection. If the two bitfields do not agree, the internal FLXPCKEN1/2 selection be mapped to 1 (enabled, default) and DCINMUX selection be mapped to the OFF position. SWn selection is determined by TOPCELL1/2 (based on TOPCELL1&2). Valid selections range from Cell 8 (0x8) to Cell 14 (0xE). If an unsupported selection (0x0 to 0x7, 0xF) is made in TOPCELL1/2, the DCINMUX selection switches are disabled, but the DCINMUX common switch is enabled (this is the default condition). In this condition, DCIN is initially pulled to a diode below the highest SWn input and there is no interference if DCIN is externally supplied. Block selection is determined by TOPBLOCK. Valid cell selections range from Cell 8 (0x8) to Cell 14 (0xE). If an unsupported selection (0x0~0x7, 0xF) is made in TOPBLOCK, the VBLK port is selected.</p>
FLXPCKEN1	14	<p>Flex Pack Enable 1 (Redundant Bitfield) 0 = Flex Pack functions disabled 1 = Flex Pack selection of top cell and top block enabled (default) See FLXPCKEN2 for complete details on operation and redundant bitfield checking.</p>

BITFIELD	BITS	DESCRIPTION
FLXPCKSCAN	13	<p>Flex Pack Scan Configuration</p> <p>0 = Flex Pack ALTMUX scan unmodified</p> <p>1 = Flex Pack ALTMUX scan modified with additional 30µs delay before acquisition of TOPCELL1/2 (default)</p> <p>FLEXPCKSCAN configure the measurement sequence such that for any scan with ALTMUXSEL = 1, there be 30µs delay prior to sampling the TOPCELL1/2 voltage regardless of SCANMODE. This delay affords the SW[TOPCELL1/2] input time to settle for an accurate diagnostic measurement when DCIN loading is temporarily suspended in Flex Pack configurations.</p> <p>Impacts scan sequences where FLXPCKEN = 1 and TOPCELL1/2 are set to a supported value (0x8 to 0xE), and ALTMUXSEL = 1 (effective value). Ignored otherwise.</p>
TOPBLOCK	11:8	<p>Top-Block Selection:</p> <p>Configures the top block position if a selection other than the VBLK pin is chosen. Used to properly determine the connection point for the VBLOCK resistive divider.</p> <p>TOPBLOCK[3:0] selects the Cn pin to be connected to the VBLOCK resistive divider. 0xF (default) selects the VBLK pin. Selections 0x0–0x7 are not supported and be mapped to 0xF (VBLK, default).</p> <p>TOPBLOCK may differ from TOPCELL1/2 if there are Bus Bars installed in channels above the top cell. TOPBLOCK is ignored if FLXPCKEN = 0.</p>
TOPCELL2	7:4	<p>Top-Cell Selection 2:</p> <p>Configures the top cell position if less than 14 channels are used. Used to properly mask the ALRTBALS diagnostic alerts (always) and to make DCINMUX selections when FLXPCKEN = 1.</p> <p>This selection is protected by a redundant bitfield. TOPCELL1 and TOPCELL2 must agree, resulting in a valid internal TOPCELL1/2 selection. If the two bitfields do not agree, no ALRTBALS alerts are masked, and the internal DCINMUX selection be mapped to the OFF position.</p> <p>0xF (default) removes all ALRTBALS masking, and places DCINMUX in the OFF position.</p> <p>Flex-Pack Behavior:</p> <p>TOPCELL1/2 selects the SW pin to be connected to the DCIN pin. Selections 0x8 to 0xE map to SW[8] to SW[14]. Selections 0x0 to 0x7 and 0xF are not supported and be mapped to an OFF position. In the OFF position, DCIN is initially pulled to a diode below the highest SWn input.</p> <p>Masking Behavior</p> <p>TOPCELL1/2 also sets masking behavior in ALRTBALS diagnostics. All selections are supported for this function.</p>
TOPCELL1	3:0	<p>Top-Cell Selection 1 (Redundant Bitfield):</p> <p>Configures the top-cell position if less than 14 channels are used. Used to properly mask the ALRTBALS diagnostic alerts (always) and to make DCINMUX selections when FLXPCKEN=1.</p> <p>See TOPCELL2 for complete details on operation and redundant bitfield checking.</p>

ALRTIRQEN (0x19)

ALRTIRQEN is a read-/write-accessible register that selects which STATUS1 alerts trigger interrupts through the ALERT interface port(s), and are included in the DCByte and Alert Packet (UART) or ALERT bit (SPI) notifications.

Note: The information in the STATUS1 register itself (or any component terms rolled up into STATUS1) is not masked/disabled by these settings, allowing the underlying data to always be available through STATUS1 readback.

BIT	15	14	13	12	11	10	9	8
Field	SCAN-ALRTEN	–	MSMTCH-ALRTEN	CELLOVST-ALRTEN	CELLUVST-ALRTEN	BLKOVST-ALRTEN	BLKUVST-ALRTEN	AUXOVST-ALRTEN
Reset	0b0	–	0b1	0b1	0b1	0b1	0b1	0b1
Access Type	Write, Read	–	Write, Read	Write, Read	Write, Read	Write, Read	Write, Read	Write, Read

BIT	7	6	5	4	3	2	1	0
Field	AUXUVST-ALRTEN	–	PEC-ALRTEN	INTRFC-ALRTEN	CAL-ALRTEN	CBAL-ALRTEN	FMEA-2ALRTEN	FMEA-1ALRTEN
Reset	0b1	–	0b1	0b1	0b1	0b1	0b1	0b1
Access Type	Write, Read	–	Write, Read	Write, Read	Write, Read	Write, Read	Write, Read	Write, Read

BITFIELD	BITS	DESCRIPTION
SCANALRTEN	15	Scan-Complete Alert Enable 0 = ALRTSCAN masked (default) 1 = ALRTSCAN enabled Disabled by default since this is not a safety feature, but a notification option. Applies to the Alert Interface only in order to support interrupt-driven applications; ALRTSCAN is never included in the UART DCByte & Alert Packet, or the SPI ALERT bit.
MSMTCHALRTEN	13	Cell-Voltage-Mismatch Alert Enable 0 = ALRTMSMTCH masked 1 = ALRTMSMTCH enabled (default) Applies to the Alert Interface, UART DCByte & Alert Packet, and SPI ALERT bit.
CELLOVSTALRTEN	12	Cell-Overvoltage-Status Summary-Alert Enable 0 = ALRTCELLOVST masked 1 = ALRTCELLOVST enabled (default) Applies to the Alert Interface, UART DCByte & Alert Packet, and SPI ALERT bit.
CELLUVSTALRTEN	11	Cell-Undervoltage-Status Summary-Alert Enable 0 = ALRTCELLUVST masked 1 = ALRTCELLUVST enabled (default) Applies to the Alert Interface, UART DCByte & Alert Packet, and SPI ALERT bit.
BLKOVSTALRTEN	10	Block-Overvoltage Status-Alert Enable 0 = ALRTBLKOVST masked 1 = ALRTBLKOVST enabled (default) Applies to the Alert Interface, UART DCByte & Alert Packet, and SPI ALERT bit.

BITFIELD	BITS	DESCRIPTION
BLKUVSTALRTEN	9	Block Undervoltage Status Alert Enable 0 = ALRTBLKUVST masked 1 = ALRTBLKUVST enabled (default) Applies to the Alert Interface, UART DCByte & Alert Packet, and SPI ALERT bit.
AUXOVSTALRTEN	8	Auxiliary Overvoltage Status Summary Alert Enable 0 = ALRTAUXOVST masked 1 = ALRTAUXOVST enabled (default) Applies to the Alert Interface, UART DCByte & Alert Packet, and SPI ALERT bit.
AUXUVSTALRTEN	7	Auxiliary Undervoltage Status Summary Alert Enable 0 = ALRTAUXUVST masked 1 = ALRTAUXUVST enabled (default) Applies to the Alert Interface, UART DCByte & Alert Packet, and SPI ALERT bit.
PECALRTEN	5	Packet Error Check (CRC) Alert Enable 0 = ALRTPEC masked 1 = ALRTPEC enabled (default) Applies to the Alert Interface, UART Alert Packet, and SPI ALERT bit; ALRT-PEC is not included in the UART DCByte.
INTRFCALRTEN	4	Interface Specific Error Alert Enable 0 = ALRTINTRFC masked 1 = ALRTINTRFC enabled (default) Applies to the Alert Interface, UART DCByte & Alert Packet, and SPI ALERT bit.
CALALRTEN	3	Calibration Fault Alert Enable 0 = ALRTCAL masked 1 = ALRTCAL enabled (default) Applies to the Alert Interface, UART DCByte & Alert Packet, and SPI ALERT bit.
CBALALRTEN	2	Cell Balancing Status Alert Enable 0 = ALRTCBAL masked 1 = ALRTCBAL enabled (default) Applies to the Alert Interface, UART DCByte & Alert Packet, and SPI ALERT bit.
FMEA2ALRTEN	1	FMEA2 Condition Summary Alert Enable 0 = ALRTFMEA2 masked 1 = ALRTFMEA2 enabled (default) Applies to the Alert Interface, UART DCByte & Alert Packet, and SPI ALERT bit.
FMEA1ALRTEN	0	FMEA1 Condition Summary Alert Enable 0 = ALRTFMEA1 masked 1 = ALRTFMEA1 enabled (default) Applies to the Alert Interface, UART DCByte & Alert Packet, and SPI ALERT bit.

ALRTOVEN (0x1A)

ALRTOVEN is a read-/write-accessible register that enables overvoltage fault checks on selected input channels during scans using either the ADC or Comparator.

BIT	15	14	13	12	11	10	9	8
Field	–	BLKOV-ALRTEN	OVALRTEN[14:9]					
Reset	–	0b0	0x0000					
Access Type	–	Write, Read	Write, Read					
BIT	7	6	5	4	3	2	1	0
Field	OVALRTEN[8:1]							
Reset	0x0000							
Access Type	Write, Read							

BITFIELD	BITS	DESCRIPTION
BLKOVVALRTEN	14	Block Overvoltage Fault Check Enable BLKOVVALRTEN enables overvoltage fault checking on ADC Block measurements against threshold BLKOVTHSET. Clearing also clears the associated Block alert.
OVALRTEN	13:0	Overvoltage Fault Check Enable OVALRTEN[n] enables overvoltage fault checking on CELL[n] against threshold OVTHSET (ADC) and COMPOVTH (Comparator). Clearing also clears the associated cell alert in ALRTOVCELL and ALRTCMPVREG.

ALRTUVEN (0x1B)

ALRTUVEN is a read-/write-accessible register that enables undervoltage fault checks on selected input channels during scans using either the ADC or Comparator.

BIT	15	14	13	12	11	10	9	8
Field	–	BLKUV-ALRTEN	UVALRTEN[14:9]					
Reset	–	0b0	0x0000					
Access Type	–	Write, Read	Write, Read					
BIT	7	6	5	4	3	2	1	0
Field	UVALRTEN[8:1]							
Reset	0x0000							
Access Type	Write, Read							

BITFIELD	BITS	DESCRIPTION
BLKUALRTEN	14	Block Undervoltage Fault Check Enable BLKUALRTEN enables undervoltage fault checking on ADC Block measurements against threshold BLKUVTHSET. Clearing also clears the associated Block alert.
UVALRTEN	13:0	Undervoltage Fault Check Enable UVALRTEN[n] enables undervoltage fault checking on CELL[n] against threshold UVTHSET (ADC) and COMPUVTH (Comparator). Clearing also clears the associated cell alert in ALRTOVCELL and ALRTCOMPOVREG.

ALRTAUXOVEN (0x1C)

ALRTAUXOVEN is a read-/write-accessible register that enables auxiliary overvoltage (cold) fault checks on selected Auxiliary channels during scans using either the ADC or Comparator.

BIT	15	14	13	12	11	10	9	8
Field	–	–	–	–	–	–	–	–
Reset	–	–	–	–	–	–	–	–
Access Type	–	–	–	–	–	–	–	–

BIT	7	6	5	4	3	2	1	0
Field	–	–	AUXOVALRTEN[5:4]		AUXOVALRTEN[3:0]			
Reset	–	–	0x0		0x00			
Access Type	–	–	Write, Read, Ext		Write, Read, Ext			

BITFIELD	BITS	DESCRIPTION
AUXOVALRTEN	5:4	Auxiliary Overvoltage (Cold) Fault Check Enable AUXOVALRTEN[n] enables overvoltage (cold) fault checking on AUX[n] against the ratiometric/absolute threshold AUXROVTHSET/AUXAOVTHSET (ADC) and COMPAUXROVTH/COMPAUXAOVTH (Comparator), as selected by AUXREFSEL[n]. Clearing also clears the associated alert. Note: If the respective GPIOEN bit is set (GPIO mode), this bit is ignored, but still readback the user setting.
AUXOVALRTEN	3:0	Auxiliary Overvoltage (Cold) Fault Check Enable AUXOVALRTEN[n] enables overvoltage (cold) fault checking on AUX[n] against the ratiometric/absolute threshold AUXROVTHSET/AUXAOVTHSET (ADC) and COMPAUXROVTH/COMPAUXAOVTH (Comparator), as selected by AUXREFSEL[n]. Clearing also clears the associated alert. Note: If the respective GPIOEN bit is set (GPIO mode), this bit is ignored, but still read back the user setting.

ALRTAUXUVEN (0x1D)

ALRTAUXUVEN is a read-/write-accessible register that enables auxiliary undervoltage (hot) fault checks on selected Auxiliary channels using either the ADC or Comparator.

BIT	15	14	13	12	11	10	9	8
Field	–	–	–	–	–	–	–	–
Reset	–	–	–	–	–	–	–	–
Access Type	–	–	–	–	–	–	–	–
BIT	7	6	5	4	3	2	1	0
Field	–	–	AUXUVALRTEN[5:4]		AUXUVALRTEN[3:0]			
Reset	–	–	0x0		0x0			
Access Type	–	–	Write, Read, Ext		Write, Read, Ext			

BITFIELD	BITS	DESCRIPTION
AUXUVALRTEN	5:4	Auxiliary Undervoltage (Hot) Fault Check Enable AUXUVALRTEN[n] enables undervoltage (hot) fault checking on AUX[n] against the ratiometric/absolute threshold AUXRUVTHSET/AUXAUVTHSET (ADC) and COMPAUXRUVTH/COMPAUXAUVTH (Comparator), as selected by AUXREFSEL[n]. Clearing also clears the associated alert. Note: If the respective GPIOEN bit is set (GPIO mode), this bit is ignored, but still readback the user setting.
AUXUVALRTEN	3:0	Auxiliary Undervoltage (Hot) Fault Check Enable AUXUVALRTEN[n] enables undervoltage (hot) fault checking on AUX[n] against the ratiometric/absolute threshold AUXRUVTHSET/AUXAUVTHSET (ADC) and COMPAUXRUVTH/COMPAUXAUVTH (Comparator), as selected by AUXREFSEL[n]. Clearing also clears the associated alert. Note: If the respective GPIOEN bit is set (GPIO mode), this bit is ignored, but still read back the user setting.

ALRTCALTST (0x1E)

ALRTCALTST is a read-/write-accessible register that allows the user to force Calibration alerts to test readback and interrupt logic. The forced alert(s) remain forced until this register is written back to zeros (assuming the existing calibration data is with range).

BIT	15	14	13	12	11	10	9	8
Field	–	–	–	–	–	–	–	–
Reset	–	–	–	–	–	–	–	–
Access Type	–	–	–	–	–	–	–	–
BIT	7	6	5	4	3	2	1	0
Field	–	–	–	CALOSAD-CALRTFRC	CALOSR-ALRTFRC	CALO-STHRM-ALRTFRC	CALGAIN-PALRTFRC	CALGAIN-RALRTFRC
Reset	–	–	–	0b0	0b0	0b0	0b0	0b0
Access Type	–	–	–	Write, Read	Write, Read	Write, Read	Write, Read	Write, Read

BITFIELD	BITS	DESCRIPTION
CALOSADCALRTFRC	4	ADC Offset Calibration Alert Force 0 = ALRTCALOSADC normal operation (default) 1 = ALRTCALOSADC forced if unmasked Used to test alert functionality.
CALOSRALRTFRC	3	Ramp LSA + ADC Offset Calibration Alert Force 0 = ALRTCALOSR normal operation (default) 1 = ALRTCALOSR forced if unmasked Used to test alert functionality.
CALOSTHRMALRTFRC	2	Ratiometric ADC Offset Calibration Alert Force 0 = ALRTCALOSTHRM normal operation (default) 1 = ALRTCALOSTHRM forced if unmasked Used to test alert functionality.
CALGAINPALRTFRC	1	Pyramid Gain Calibration Alert Force 0 = ALRTCALGAINP normal operation (default) 1 = ALRTCALGAINP forced if unmasked Used to test alert functionality.
CALGAINRALRTFRC	0	Ramp Gain Calibration Alert Force 0 = ALRTCALGAINR normal operation (default) 1 = ALRTCALGAINR forced if unmasked Used to test alert functionality.

OVTHCLRREG (0x1F)

OVTHCLR is a read-/write-accessible register that selects the cell overvoltage alert clear threshold used with unipolar ADC measurements.

BIT	15	14	13	12	11	10	9	8
Field	OVTHCLR[13:6]							
Reset	0x3FFF							
Access Type	Write, Read							
BIT	7	6	5	4	3	2	1	0
Field	OVTHCLR[5:0]						–	–
Reset	0x3FFF						–	–
Access Type	Write, Read						–	–

BITFIELD	BITS	DESCRIPTION
OVTHCLR	15:2	Unipolar Cell Overvoltage Alert Clear Threshold 14-bit threshold value at/below which ALRTOV alerts be cleared/deasserted for unipolar cell measurements. Note: For proper operation, this value should always be less than or equal to OVTHSET.

OVTHSETREG (0x20)

OVTHSET is a read-/write-accessible register that selects the cell overvoltage alert set threshold used with unipolar ADC measurements.

BIT	15	14	13	12	11	10	9	8
Field	OVTHSET[13:6]							
Reset	0x3FFF							
Access Type	Write, Read							
BIT	7	6	5	4	3	2	1	0
Field	OVTHSET[5:0]						–	–
Reset	0x3FFF						–	–
Access Type	Write, Read						–	–

BITFIELD	BITS	DESCRIPTION
OVTHSET	15:2	Unipolar Cell Overvoltage Alert Set Threshold 14-bit threshold value above which ALRTOV alerts be set/asserted for unipolar cell measurements. A value of 0x3FFF effectively disables overvoltage checking.

UVTHCLRREG (0x21)

UVTHCLR is a read-/write-accessible register that selects the cell undervoltage alert clear threshold used with unipolar ADC measurements.

BIT	15	14	13	12	11	10	9	8
Field	UVTHCLR[13:6]							
Reset	0x0000							
Access Type	Write, Read							
BIT	7	6	5	4	3	2	1	0
Field	UVTHCLR[5:0]						–	–
Reset	0x0000						–	–
Access Type	Write, Read						–	–

BITFIELD	BITS	DESCRIPTION
UVTHCLR	15:2	Unipolar Cell Undervoltage Alert Clear Threshold 14-bit threshold value at/above which ALRTUV alerts be cleared/deasserted for unipolar cell measurements. Note: For proper operation, this value should always be greater than or equal to UVTHSET.

UVTHSETREG (0x22)

UVTHSET is a read-/write-accessible register that selects the cell undervoltage alert set threshold used with unipolar ADC measurements.

BIT	15	14	13	12	11	10	9	8
Field	UVTHSET[13:6]							
Reset	0x0000							
Access Type	Write, Read							
BIT	7	6	5	4	3	2	1	0
Field	UVTHSET[5:0]						–	–
Reset	0x0000						–	–
Access Type	Write, Read						–	–

BITFIELD	BITS	DESCRIPTION
UVTHSET	15:2	Unipolar Cell Undervoltage Alert Set Threshold 14-bit threshold value below which ALRTUV alerts be set/asserted for unipolar cell measurements. A value of 0x0000 effectively disables undervoltage checking.

MSMTCHREG ((0x23))

MSMTCH is a read-/write-accessible register that selects the cell-voltage-mismatch alert threshold used with ADC cell scan measurements.

BIT	15	14	13	12	11	10	9	8
Field	MSMTCH[13:6]							
Reset	0x3FFF							
Access Type	Write, Read							
BIT	7	6	5	4	3	2	1	0
Field	MSMTCH[5:0]						–	–
Reset	0x3FFF						–	–
Access Type	Write, Read						–	–

BITFIELD	BITS	DESCRIPTION
MSMTCH	15:2	Cell-Voltage-Mismatch Alert Threshold 14-bit threshold value; if the difference between maximum and minimum cell voltages exceeds this value, ALRTMSMTCH be set/asserted. Whether only unipolar ADC measurements (POLARITYn = 0) are included in mismatch calculations or all measurements are included is determined by POLARITYCTRL:MINMAXPOL.

BIPOVTHCLRREG (0x24)

BIPOVTHCLR is a read-/write-accessible register that selects the cell overvoltage alert clear threshold used with bipolar ADC measurements.

BIT	15	14	13	12	11	10	9	8
Field	BIPOVTHCLR[13:6]							
Reset	0x3FFF							
Access Type	Write, Read							
BIT	7	6	5	4	3	2	1	0
Field	BIPOVTHCLR[5:0]						–	–
Reset	0x3FFF						–	–
Access Type	Write, Read						–	–

BITFIELD	BITS	DESCRIPTION
BIPOVTHCLR	15:2	Bipolar Cell Overvoltage Alert Clear Threshold 14-bit threshold value at/below which ALRTOV alerts be cleared/deasserted for bipolar cell measurements. Bipolar format. Note: For proper operation, this value should always be less than or equal to BIPOVTHSET.

BIPOVTHSETREG (0x25)

BIPOVTHSET is a read-/write-accessible register that selects the cell overvoltage alert set threshold used with bipolar ADC measurements.

BIT	15	14	13	12	11	10	9	8
Field	BIPOVTHSET[13:6]							
Reset	0x3FFF							
Access Type	Write, Read							
BIT	7	6	5	4	3	2	1	0
Field	BIPOVTHSET[5:0]						–	–
Reset	0x3FFF						–	–
Access Type	Write, Read						–	–

BITFIELD	BITS	DESCRIPTION
BIPOVTHSET	15:2	Bipolar Cell Overvoltage Alert Set Threshold 14-bit threshold value above which ALRTOV alerts be set/asserted for bipolar cell measurements. Bipolar format. A value of 0x3FFF effectively disables overvoltage checking.

BIPUVTHCLRREG (0x26)

BIPUVTHCLR is a read-/write-accessible register that selects the cell undervoltage alert clear threshold used with bipolar ADC measurements.

BIT	15	14	13	12	11	10	9	8
Field	BIPUVTHCLR[13:6]							
Reset	0x0000							
Access Type	Write, Read							
BIT	7	6	5	4	3	2	1	0
Field	BIPUVTHCLR[5:0]						–	–
Reset	0x0000						–	–
Access Type	Write, Read						–	–

BITFIELD	BITS	DESCRIPTION
BIPUVTHCLR	15:2	Bipolar Cell Undervoltage Alert Clear Threshold 14-bit threshold value at/above which ALRTUV alerts be cleared/deasserted for bipolar cell measurements. Bipolar format. Note: For proper operation, this value should always be greater than or equal to BIPUVTHSET.

BIPUVTHSETREG (0x27)

BIPUVTHSET is a read-/write-accessible register that selects the cell undervoltage alert set threshold used with bipolar ADC measurements.

BIT	15	14	13	12	11	10	9	8
Field	BIPUVTHSET[13:6]							
Reset	0x0000							
Access Type	Write, Read							
BIT	7	6	5	4	3	2	1	0
Field	BIPUVTHSET[5:0]						–	–
Reset	0x0000						–	–
Access Type	Write, Read						–	–

BITFIELD	BITS	DESCRIPTION
BIPUVTHSET	15:2	Bipolar Cell Undervoltage Alert Set Threshold 14-bit threshold value below which ALRTUV alerts be set/asserted for bipolar cell measurements. Bipolar format. A value of 0x0000 effectively disables undervoltage checking.

BLKOVTHCLRREG (0x28)

BLKOVTHCLR is a read-/write-accessible register that selects the block overvoltage alert clear threshold used with ADC measurements.

BIT	15	14	13	12	11	10	9	8
Field	BLKOVTHCLR[13:6]							
Reset	0x3FFF							
Access Type	Write, Read							
BIT	7	6	5	4	3	2	1	0
Field	BLKOVTHCLR[5:0]						–	–
Reset	0x3FFF						–	–
Access Type	Write, Read						–	–

BITFIELD	BITS	DESCRIPTION
BLKOVTHCLR	15:2	Block Overvoltage Alert Clear Threshold 14-bit threshold value at/below which the ALRTBLKOV alert be cleared/deasserted. Note: For proper operation, this value should always be less than or equal to BLKOVTHSET.

BLKOVTHSETREG (0x29)

BLKOVTHSET is a read-/write-accessible register that selects the block overvoltage alert set threshold used with ADC measurements.

BIT	15	14	13	12	11	10	9	8
Field	BLKOVTHSET[13:6]							
Reset	0x3FFF							
Access Type	Write, Read							
BIT	7	6	5	4	3	2	1	0
Field	BLKOVTHSET[5:0]						–	–
Reset	0x3FFF						–	–
Access Type	Write, Read						–	–

BITFIELD	BITS	DESCRIPTION
BLKOVTHSET	15:2	Block Overvoltage Alert Set Threshold 14-bit threshold value above which the ALRTBLKOV alert be set/asserted. A value of 0x3FFF effectively disables overvoltage checking.

BLKUVTHCLRREG (0x2A)

BLKUVTHCLR is a read-/write-accessible register that selects the block undervoltage alert clear threshold used with ADC measurements.

BIT	15	14	13	12	11	10	9	8
Field	BLKUVTHCLR[13:6]							
Reset	0x0000							
Access Type	Write, Read							
BIT	7	6	5	4	3	2	1	0
Field	BLKUVTHCLR[5:0]						–	–
Reset	0x0000						–	–
Access Type	Write, Read						–	–

BITFIELD	BITS	DESCRIPTION
BLKUVTHCLR	15:2	Block Undervoltage Alert Clear Threshold 14-bit threshold value at/above which the ALRTBLKUV alert be cleared/deasserted. Note: For proper operation, this value should always be greater than or equal to BLKUVTHSET.

BLKUVTHSETREG (0x2B)

BLKUVTHSET is a read-/write-accessible register that selects the block undervoltage alert set threshold used with ADC measurements.

BIT	15	14	13	12	11	10	9	8
Field	BLKUVTHSET[13:6]							
Reset	0x0000							
Access Type	Write, Read							
BIT	7	6	5	4	3	2	1	0
Field	BLKUVTHSET[5:0]						–	–
Reset	0x0000						–	–
Access Type	Write, Read						–	–

BITFIELD	BITS	DESCRIPTION
BLKUVTHSET	15:2	Block Undervoltage Alert Set Threshold 14-bit threshold value below which the ALRTBLKUV alert be set/asserted. A value of 0x0000 effectively disables undervoltage checking.

AUXROVTHCLRREG (0x30)

AUXROVTHCLR is a read-/write-accessible register that selects the overvoltage (cold) alert clear threshold used with ratiometric auxiliary ADC measurements.

BIT	15	14	13	12	11	10	9	8
Field	AUXROVTHCLR[13:6]							
Reset	0x3FFF							
Access Type	Write, Read							
BIT	7	6	5	4	3	2	1	0
Field	AUXROVTHCLR[5:0]						–	–
Reset	0x3FFF						–	–
Access Type	Write, Read						–	–

BITFIELD	BITS	DESCRIPTION
AUXROVTHCLR	15:2	<p>Ratiometric Auxiliary Overvoltage (Cold) Alert Clear Threshold 14-bit overvoltage (cold) clear threshold value, at/below which ALRTAUXOV alerts be cleared/deasserted. This threshold is applied for Auxiliary measurements where AUXREFSELn = 0 (ratio metric). Note: For proper operation, this value should always be less than or equal to AUXROVTHSET.</p>

AUXROVTHSETREG (0x31)

AUXROVTHSET is a read-/write-accessible register that selects the overvoltage (cold) alert set threshold used with Ratiometric Auxiliary ADC measurements.

BIT	15	14	13	12	11	10	9	8
Field	AUXROVTHSET[13:6]							
Reset	0x3FFF							
Access Type	Write, Read							
BIT	7	6	5	4	3	2	1	0
Field	AUXROVTHSET[5:0]						–	–
Reset	0x3FFF						–	–
Access Type	Write, Read						–	–

BITFIELD	BITS	DESCRIPTION
AUXROVTHSET	15:2	<p>Ratiometric Auxiliary Overvoltage (Cold) Alert Set Threshold 14-bit overvoltage (cold) set threshold value, above which ALRTAUXOV alerts be asserted. This threshold is applied for Auxiliary measurements where AUXREFSELn = 0 (Ratio metric). A value of 0x3FFF effectively disables overvoltage checking.</p>

AUXRUVTHCLRREG (0x32)

AUXRUVTHCLR is a read/write-accessible register that selects the undervoltage (hot) alert clear threshold used with ratiometric auxiliary ADC measurements.

BIT	15	14	13	12	11	10	9	8
Field	AUXRUVTHCLR[13:6]							
Reset	0x0000							
Access Type	Write, Read							
BIT	7	6	5	4	3	2	1	0
Field	AUXRUVTHCLR[5:0]						–	–
Reset	0x0000						–	–
Access Type	Write, Read						–	–

BITFIELD	BITS	DESCRIPTION
AUXRUVTHCLR	15:2	Ratiometric Auxiliary Undervoltage (Hot) Alert Clear Threshold 14-bit undervoltage (hot) clear threshold value, at/above which ALRTAUXUV alerts be cleared/deasserted. This threshold is applied for Auxiliary measurements where AUXREFSELn = 0 (ratio metric). Note: For proper operation, this value should always be greater than or equal to AUXRUVTHSET.

AUXRUVTHSETREG (0x33)

AUXRUVTHSET is a read/write-accessible register that selects the undervoltage (hot) alert set threshold used with ratiometric auxiliary ADC measurements.

BIT	15	14	13	12	11	10	9	8
Field	AUXRUVTHSET[13:6]							
Reset	0x0000							
Access Type	Write, Read							
BIT	7	6	5	4	3	2	1	0
Field	AUXRUVTHSET[5:0]						–	–
Reset	0x0000						–	–
Access Type	Write, Read						–	–

BITFIELD	BITS	DESCRIPTION
AUXRUVTHSET	15:2	Ratiometric Auxiliary Undervoltage (Hot) Alert Set Threshold 14-bit undervoltage (hot) set threshold value, below which ALRTAUXUV alerts be asserted. This threshold is applied for Auxiliary measurements where AUXREFSELn = 0 (ratio metric). A value of 0x0000 effectively disables undervoltage checking.

AUXAOVTHCLRREG (0x34)

AUXOVTHCLR is a read-/write-accessible register that selects the overvoltage alert clear threshold used with Absolute Auxiliary ADC measurements.

BIT	15	14	13	12	11	10	9	8
Field	AUXAOVTHCLR[13:6]							
Reset	0x3FFF							
Access Type	Write, Read							
BIT	7	6	5	4	3	2	1	0
Field	AUXAOVTHCLR[5:0]						–	–
Reset	0x3FFF						–	–
Access Type	Write, Read						–	–

BITFIELD	BITS	DESCRIPTION
AUXAOVTHCLR	15:2	<p>Absolute Auxiliary Overvoltage Alert Clear Threshold 14-bit overvoltage clear threshold value, at/below which ALRTAUXOV alerts be cleared/deasserted. This threshold is applied for Auxiliary measurements where AUXREFSELn = 1 (Absolute). Note: For proper operation, this value should always be less than or equal to AUXAOVTHSET.</p>

AUXAOVTHSETREG ((0x35))

AUXAOVTHSET is a read-/write-accessible register that selects the overvoltage alert set threshold used with Absolute Auxiliary ADC measurements.

BIT	15	14	13	12	11	10	9	8
Field	AUXAOVTHSET[13:6]							
Reset	0x3FFF							
Access Type	Write, Read							
BIT	7	6	5	4	3	2	1	0
Field	AUXAOVTHSET[5:0]						–	–
Reset	0x3FFF						–	–
Access Type	Write, Read						–	–

BITFIELD	BITS	DESCRIPTION
AUXAOVTHSET	15:2	<p>Auxiliary Overvoltage Alert Set Threshold 14-bit overvoltage set threshold value, above which ALRTAUXOV alerts be asserted. This threshold is applied for Auxiliary measurements where AUXREFSELn = 1 (Absolute). A value of 0x3FFF effectively disables overvoltage checking.</p>

AUXAUVTHCLRREG (0x36)

AUXAUVTHCLR is a read-/write-accessible register that selects the undervoltage alert clear threshold used with Absolute Auxiliary ADC measurements.

BIT	15	14	13	12	11	10	9	8
Field	AUXAUVTHCLR[13:6]							
Reset	0x0000							
Access Type	Write, Read							
BIT	7	6	5	4	3	2	1	0
Field	AUXAUVTHCLR[5:0]						–	–
Reset	0x0000						–	–
Access Type	Write, Read						–	–

BITFIELD	BITS	DESCRIPTION
AUXAUVTHCLR	15:2	<p>Absolute Auxiliary Undervoltage Alert Clear Threshold 14-bit undervoltage clear threshold value, at/above which ALRTAUXUV alerts be cleared/deasserted. This threshold is applied for Auxiliary measurements where AUXREFSELn = 1 (Absolute). Note: For proper operation, this value should always be greater than or equal to AUXAUVTHSET.</p>

AUXAUVTHSETREG (0x37)

AUXAUVTHSET is a read-/write-accessible register that selects the undervoltage alert set threshold used with Absolute Auxiliary ADC measurements.

BIT	15	14	13	12	11	10	9	8
Field	AUXAUVTHSET[13:6]							
Reset	0x0000							
Access Type	Write, Read							
BIT	7	6	5	4	3	2	1	0
Field	AUXAUVTHSET[5:0]						–	–
Reset	0x0000						–	–
Access Type	Write, Read						–	–

BITFIELD	BITS	DESCRIPTION
AUXAUVTHSET	15:2	<p>Absolute Auxiliary Undervoltage Alert Set Threshold 14-bit undervoltage set threshold value, below which ALRTAUXUV alerts be asserted. This threshold is applied for Auxiliary measurements where AUXREFSELn = 1 (Absolute). A value of 0x0000 effectively disables undervoltage checking.</p>

COMPOVTHREG (0x38)

COMPOVTH is a read-/write-accessible register that selects the cell overvoltage alert threshold for the redundant comparator.

BIT	15	14	13	12	11	10	9	8
Field	COMPOVTH[9:2]							
Reset	0x3FF							
Access Type	Write, Read							
BIT	7	6	5	4	3	2	1	0
Field	COMPOVTH[1:0]		–	–	–	–	–	–
Reset	0x3FF		–	–	–	–	–	–
Access Type	Write, Read		–	–	–	–	–	–

BITFIELD	BITS	DESCRIPTION
COMPOVTH	15:6	Comparator Cell Overvoltage Alert Threshold 10-bit threshold value, of a 5V input range, above which ALRTCOMPOV alerts be set/asserted by comparator scans. A value of 0x3FF effectively disables overvoltage checking. Note: For proper operation, this value should always be greater than or equal to COMPUVTH.

COMPUVTHREG (0x39)

COMPUVTH is a read-/write-accessible register that selects the cell undervoltage alert threshold for the redundant comparator.

BIT	15	14	13	12	11	10	9	8
Field	COMPUVTH[9:2]							
Reset	0x000							
Access Type	Write, Read							
BIT	7	6	5	4	3	2	1	0
Field	COMPUVTH[1:0]		–	–	–	–	–	–
Reset	0x000		–	–	–	–	–	–
Access Type	Write, Read		–	–	–	–	–	–

BITFIELD	BITS	DESCRIPTION
COMPUVTH	15:6	Comparator Cell Undervoltage Alert Threshold 10-bit threshold value, of a 5V input range, below which ALRTCOMPUV alerts be set/asserted by comparator scans. A value of 0x000 effectively disables undervoltage checking. Note: For proper operation, his value should always be less than or equal to COMPOVTH.

COMPAUXROVTHREG (0x3A)

COMPAUXROVTH is a read-/write-accessible register that selects the overvoltage (cold) alert threshold applied during ratiometric auxiliary comparator measurements.

BIT	15	14	13	12	11	10	9	8
Field	COMPAUXROVTH[9:2]							
Reset	0x3FF							
Access Type	Write, Read							
BIT	7	6	5	4	3	2	1	0
Field	COMPAUXROVTH[1:0]		–	–	–	–	–	–
Reset	0x3FF		–	–	–	–	–	–
Access Type	Write, Read		–	–	–	–	–	–

BITFIELD	BITS	DESCRIPTION
COMPAUXROVTH	15:6	<p>Comparator Ratiometric Auxiliary Overvoltage (Cold) Alert Threshold 10-bit overvoltage (cold) threshold value of a input range of V_{AA}, above which ALRTCOMPAUXOV alerts be set/asserted by comparator scans. This threshold is applied for Auxiliary measurements where AUXREFSELn = 0 (ratio metric). A value of 0x3FF effectively disables overvoltage checking. Note: For proper operation, this value should always be greater than or equal to COMPAUXRUVTH.</p>

COMPAUXRUVTHREG (0x3B)

COMPAUXRUVTH is a read-/write-accessible register that selects the undervoltage (hot) alert threshold applied during ratiometric auxiliary comparator measurements.

BIT	15	14	13	12	11	10	9	8
Field	COMPAUXRUVTH[9:2]							
Reset	0x000							
Access Type	Write, Read							
BIT	7	6	5	4	3	2	1	0
Field	COMPAUXRUVTH[1:0]		–	–	–	–	–	–
Reset	0x000		–	–	–	–	–	–
Access Type	Write, Read		–	–	–	–	–	–

BITFIELD	BITS	DESCRIPTION
COMPAUXRUVTH	15:6	<p>Comparator Ratiometric Auxiliary Undervoltage (Hot) Alert Threshold 10-bit undervoltage (hot) threshold value of a input range of V_{AA}, below which ALRTCOMPAUXUV alerts be set/asserted by comparator scans. This threshold is applied for Auxiliary measurements where AUXREFSELn=0 (ratio metric). A value of 0x000 effectively disables undervoltage checking. Note: For proper operation, this value should always be less than or equal to COMPAUXROVTH.</p>

COMPAUXAOVTHREG (0x3C)

COMPAUXAOVTH is a read-/write-accessible register that selects the overvoltage alert threshold applied during Absolute Auxiliary comparator measurements.

BIT	15	14	13	12	11	10	9	8
Field	COMPAUXAOVTH[9:2]							
Reset	0x3FF							
Access Type	Write, Read							
BIT	7	6	5	4	3	2	1	0
Field	COMPAUXAOVTH[1:0]		–	–	–	–	–	–
Reset	0x3FF		–	–	–	–	–	–
Access Type	Write, Read		–	–	–	–	–	–

BITFIELD	BITS	DESCRIPTION
COMPAUXAOVTH	15:6	<p>Comparator Absolute Auxiliary Overvoltage Alert Threshold 10-bit overvoltage threshold value, of an input range of V_{REF}, above which ALRTCOMPAUXOV alerts be set/asserted by comparator scans. This threshold is applied for Auxiliary measurements where AUXREFSELn = 1 (Absolute). A value of 0x3FF effectively disables overvoltage checking. Note: For normal operation, this value should always be greater than or equal to COMPAUXAUVTH.</p>

COMPAUXAUVTHREG (0x3D)

COMPAUXAUVTH is a read-/write-accessible register that selects the undervoltage alert threshold applied during Absolute Auxiliary comparator measurements.

BIT	15	14	13	12	11	10	9	8
Field	COMPAUXAUVTH[9:2]							
Reset	0x000							
Access Type	Write, Read							
BIT	7	6	5	4	3	2	1	0
Field	COMPAUXAUVTH[1:0]		–	–	–	–	–	–
Reset	0x000		–	–	–	–	–	–
Access Type	Write, Read		–	–	–	–	–	–

BITFIELD	BITS	DESCRIPTION
COMPAUXAUVTH	15:6	<p>Comparator Absolute Auxiliary Undervoltage Alert Threshold 10-bit undervoltage threshold value, of an input range of V_{REF}, below which ALRTCOMPAUXUV alerts be set/asserted by comparator scans. This threshold is applied for Auxiliary measurements where AUXREFSELn = 1 (Absolute). A value of 0x000 effectively disables undervoltage checking. Note: For proper operation, this value should always be less than or equal to COMPAUXAOVTH.</p>

COMPOPNTHREG (0x3E)

COMPOPNTH is a read-/write-accessible register that selects the undervoltage alert threshold applied to Unipolar Cell inputs in Open Diagnostic Mode.

BIT	15	14	13	12	11	10	9	8
Field	COMPOPNTH[9:2]							
Reset	0x000							
Access Type	Write, Read							
BIT	7	6	5	4	3	2	1	0
Field	COMPOPNTH[1:0]		–	–	–	–	–	–
Reset	0x000		–	–	–	–	–	–
Access Type	Write, Read		–	–	–	–	–	–

BITFIELD	BITS	DESCRIPTION
COMPOPNTH	15:6	Comparator Cell Open Undervoltage Alert Threshold 10-bit threshold of a 5V input range, below which ALRTCOMPUV alerts be set/asserted by comparator scans performed on Unipolar Cell inputs in Open Diagnostic Mode (see CTSTCFG:CELLOPNDIAGSEL). A value of 0x000 effectively disables open undervoltage checking.

COMPAUXROPNTHREG (0x3F)

COMPAUXROPNTH is a read-/write-accessible register that selects the undervoltage alert threshold applied to ratio-metric auxiliary inputs in open-diagnostic mode.

BIT	15	14	13	12	11	10	9	8
Field	COMPAUXROPNTH[9:2]							
Reset	0x000							
Access Type	Write, Read							
BIT	7	6	5	4	3	2	1	0
Field	COMPAUXROPNTH[1:0]		–	–	–	–	–	–
Reset	0x000		–	–	–	–	–	–
Access Type	Write, Read		–	–	–	–	–	–

BITFIELD	BITS	DESCRIPTION
COMPAUXROPNTH	15:6	Comparator Ratiometric Auxiliary Open Undervoltage Alert Threshold: 10-bit undervoltage threshold value, of an input range of V_{AA} , below which ALRTCOMPAUXUV alerts be set/asserted by comparator scans performed on ratiometric auxiliary inputs in open-diagnostic mode (see DIAGGENCFG:AUXDIAGSEL). This threshold is applied for auxiliary measurements where AUXREFSELn = 0 (ratio metric). A value of 0x000 effectively disables undervoltage checking.

COMPAUXAOPNTHREG (0x40)

COMPAUXAOPNTH is a read-/write-accessible register that selects the undervoltage alert threshold applied to Absolute Auxiliary inputs in Open Diagnostic Mode.

BIT	15	14	13	12	11	10	9	8
Field	COMPAUXAOPNTH[9:2]							
Reset	0x000							
Access Type	Write, Read							
BIT	7	6	5	4	3	2	1	0
Field	COMPAUXAOPNTH[1:0]		–	–	–	–	–	–
Reset	0x000		–	–	–	–	–	–
Access Type	Write, Read		–	–	–	–	–	–

BITFIELD	BITS	DESCRIPTION
COMPAUXAOPNTH	15:6	Comparator Absolute Auxiliary Open Undervoltage Alert Threshold 10-bit undervoltage threshold value, of an input range of V_{REF} , below which ALRTCOMPAUXUV alerts be set/asserted by comparator scans performed on Absolute Auxiliary inputs in Open Diagnostic Mode (see DIAGGENCFG:AUXDIAGSEL). This threshold is applied for Auxiliary measurements where AUXREFSELn = 1 (Absolute). A value of 0x000 effectively disables undervoltage checking.

COMPACCOVTHREG (0x41)

COMPACCOVTH is a read-/write-accessible register that selects the overvoltage alert threshold applied during comparator accuracy diagnostics.

BIT	15	14	13	12	11	10	9	8
Field	COMPACCOVTH[9:2]							
Reset	0x3FF							
Access Type	Write, Read							
BIT	7	6	5	4	3	2	1	0
Field	COMPACCOVTH[1:0]		–	–	–	–	–	–
Reset	0x3FF		–	–	–	–	–	–
Access Type	Write, Read		–	–	–	–	–	–

BITFIELD	BITS	DESCRIPTION
COMPACCOVTH	15:6	End-of-Sequence Comparator Accuracy Diagnostic Overvoltage Alert Threshold 10-bit overvoltage threshold value of a 5V input range, used to validate the accuracy of the comparator at the end of any measurement sequence using the comparator if enabled (SCANCFG = 001 or 010 and COMPACCEN = 1). Tested for the Cell Signal Path with $COMP_{IN} = V_{REF}$ through LSA2 (gain = 6/13) and $DAC_{REF} = V_{REF}$. A value above COMPACCOVTH result in the ALRTCOMPACCOV bit being set/asserted. 0x1D8 is the ideal value. A precise value can be selected based on information from the Comparator Cell Signal Path Fault diagnostic. A value of 0x3FF effectively disables overvoltage checking (default).

COMPACCUVTHREG (0x42)

COMPACCUVTH is a read-/write-accessible register that selects the undervoltage alert threshold applied during comparator accuracy diagnostics.

BIT	15	14	13	12	11	10	9	8
Field	COMPACCUVTH[9:2]							
Reset	0x000							
Access Type	Write, Read							
BIT	7	6	5	4	3	2	1	0
Field	COMPACCUVTH[1:0]		–	–	–	–	–	–
Reset	0x000		–	–	–	–	–	–
Access Type	Write, Read		–	–	–	–	–	–

BITFIELD	BITS	DESCRIPTION
COMPACCUVTH	15:6	End-of-Sequence Comparator Accuracy Diagnostic Undervoltage Alert Threshold 10-bit undervoltage threshold value of a 5V input range, used to validate the accuracy of the comparator at the end of any measurement sequence using the comparator if enabled (SCANCFG = 001 or 010 and COMPACCEN = 1). Tested for the Cell Signal Path with $COMP_{IN} = V_{REF}$ through LSA2 (gain = 6/13) and $DAC_{REF} = V_{REF}$. A value below COMPACCUVTH result in the ALRT-COMPACCUV bit being set/asserted. 0x1D8 is the ideal value. A precise value can be selected based on information from the Comparator Cell Signal Path Fault diagnostic. A value of 0x000 effectively disables undervoltage checking (default).

BALSHRTTHRREG (0x43)

BALSHRTTHR is a read-/write-accessible register that selects alert threshold used during the Balance Switch Short Diagnostic mode.

BIT	15	14	13	12	11	10	9	8
Field	BALSHRTTHR[13:6]							
Reset	0x0000							
Access Type	Write, Read							
BIT	7	6	5	4	3	2	1	0
Field	BALSHRTTHR[5:0]						–	–
Reset	0x0000						–	–
Access Type	Write, Read						–	–

BITFIELD	BITS	DESCRIPTION
BALSHRTTHR	15:2	<p>Balance Switch Short Diagnostic Alert Threshold</p> <p>14-bit undervoltage threshold used for the balancing switch short circuit diagnostic test (SCANCFG = 100).</p> <p>Unipolar format. For BALS Short Diagnostics, only cells with (POLARITY_n = 0 and CELLEN_n = 1) are measured and checked.</p> <p>The unipolar ADC cell-voltage results taken in this mode are compared against the threshold; if any result is below the threshold, it is flagged as a balancing switch alert (ALRTBALSW). Results above the threshold are considered normal. The threshold should be set by the system controller prior to making a diagnostic measurement.</p>

BALLOWTHRREG ((0x44))

BALLOWTHR is a read-/write-accessible register that selects alert low threshold used during the Balance Switch Open Diagnostic mode.

BIT	15	14	13	12	11	10	9	8
Field	BALLOWTHR[13:6]							
Reset	0x0000							
Access Type	Write, Read							
BIT	7	6	5	4	3	2	1	0
Field	BALLOWTHR[5:0]						–	–
Reset	0x0000						–	–
Access Type	Write, Read						–	–

BITFIELD	BITS	DESCRIPTION
BALLOWTHR	15:2	<p>Balance Switch Open Diagnostic Alert Low Threshold</p> <p>14-bit undervoltage threshold used for the balancing switch conducting and cell sense wire diagnostic tests (SCANCFG=101, 110, and 111).</p> <p>Bipolar format, typically a small positive value is selected. For BALS Open Diagnostics, only cells with (POLARITY_n = 0 and BALS_{WEN}_n = 1) are measured and checked. For Cell Sense Open Odd/Even Diagnostics, only odd/even cells at/below TOPCELL/2 with POLARITY_n = 0 and are measured and checked.</p> <p>The bipolar ADC cell results in this mode are compared against the threshold; if any result is below the threshold, it is flagged as a balancing switch alert (ALRTBALSW). Results above the threshold are considered normal. The threshold should be set by the system controller prior to making a diagnostic measurement.</p>

BALHIGHTHRREG (0x45)

BALHIGHTHR is a read-/write-accessible register that selects alert High threshold used during the Balance Switch Open Diagnostic mode.

BIT	15	14	13	12	11	10	9	8
Field	BALHIGHTHR[13:6]							
Reset	0x0000							
Access Type	Write, Read							
BIT	7	6	5	4	3	2	1	0
Field	BALHIGHTHR[5:0]						-	-
Reset	0x0000						-	-
Access Type	Write, Read						-	-

BITFIELD	BITS	DESCRIPTION
BALHIGHTHR	15:2	Balance Switch Open Diagnostic Alert High Threshold 14-bit overvoltage threshold used for the balancing switch conducting and cell sense wire diagnostic tests (SCANCFG = 101, 110, 111). Bipolar format, typically a moderate positive value is selected, based on external resistor characteristics. For BALSW Open Diagnostics, only cells with (POLARITYn = 0 and BALSWENn = 1) are measured and checked. For Cell Sense Open Odd/Even Diagnostics, only odd/even cells at/below TOP-CELL1/2 with POLARITYn = 0 and are measured and checked. The bipolar ADC cell results in this mode are compared against the threshold; if any result is above the threshold, it is flagged as a balancing switch alert (ALRTBALSW). Results below the threshold are considered normal. The threshold should be set by the system controller prior to making a diagnostic measurement.

CELL1REG (0x47)

CELLn is a read-accessible register that holds the current value for each individual cell measurement result.

BIT	15	14	13	12	11	10	9	8
Field	CELL1[13:6]							
Reset	0x0000							
Access Type	Read Only							
BIT	7	6	5	4	3	2	1	0
Field	CELL1[5:0]						-	-
Reset	0x0000						-	-
Access Type	Read Only						-	-

BITFIELD	BITS	DESCRIPTION
CELL1	15:2	Cell-Voltage-Measurement Result: CELLn[13:0] contains the 14-bit measurement result for CELLn. Full-scale input range of 5V If CELLEN = 0, and the measurement was skipped during the latest ADC Scan, no internal data is updated, and ALU/IIR readback be determined by RDFILT. Read only.

CELL2REG (0x48)

CELLn is a read-accessible register that holds the current value for each individual cell measurement result.

BIT	15	14	13	12	11	10	9	8
Field	CELL2[13:6]							
Reset	0x0000							
Access Type	Read Only							
BIT	7	6	5	4	3	2	1	0
Field	CELL2[5:0]						–	–
Reset	0x0000						–	–
Access Type	Read Only						–	–

BITFIELD	BITS	DESCRIPTION
CELL2	15:2	Cell-Voltage-Measurement Result: CELLn[13:0] contains the 14-bit measurement result for CELLn. Full-scale input range of 5V If CELLEN = 0, and the measurement was skipped during the latest ADC Scan, no internal data is updated, and ALU/IIR readback be determined by RDFILT. Read only.

CELL3REG (0x49)

CELLn is a read-accessible register that holds the current value for each individual cell measurement result.

BIT	15	14	13	12	11	10	9	8
Field	CELL3[13:6]							
Reset	0x0000							
Access Type	Read Only							
BIT	7	6	5	4	3	2	1	0
Field	CELL3[5:0]						–	–
Reset	0x0000						–	–

Access Type	Read Only		-	-
BITFIELD	BITS	DESCRIPTION		
CELL3	15:2	Cell-Voltage-Measurement Result: CELLn[13:0] contains the 14-bit measurement result for CELLn. Full-scale input range of 5V If CELLEN = 0, and the measurement was skipped during the latest ADC Scan, no internal data is updated, and ALU/IIR readback be determined by RDFILT. Read only.		

CELL4REG (0x4A)

CELLn is a read-accessible register that holds the current value for each individual cell measurement result.

BIT	15	14	13	12	11	10	9	8
Field	CELL4[13:6]							
Reset	0x0000							
Access Type	Read Only							
BIT	7	6	5	4	3	2	1	0
Field	CELL4[5:0]						-	-
Reset	0x0000						-	-
Access Type	Read Only						-	-

BITFIELD	BITS	DESCRIPTION		
CELL4	15:2	Cell-Voltage-Measurement Result: CELLn[13:0] contains the 14-bit measurement result for CELLn. Full-scale input range of 5V If CELLEN = 0, and the measurement was skipped during the latest ADC Scan, no internal data is updated, and ALU/IIR readback be determined by RDFILT. Read only.		

CELL5REG (0x4B)

CELLn is a read-accessible register that holds the current value for each individual cell measurement result.

BIT	15	14	13	12	11	10	9	8
Field	CELL5[13:6]							
Reset	0x0000							
Access Type	Read Only							
BIT	7	6	5	4	3	2	1	0
Field	CELL5[5:0]						-	-
Reset	0x0000						-	-
Access Type	Read Only						-	-

BITFIELD	BITS	DESCRIPTION
CELL5	15:2	Cell-Voltage-Measurement Result: CELLn[13:0] contains the 14-bit measurement result for CELLn. Full-scale input range of 5V If CELLEN = 0, and the measurement was skipped during the latest ADC Scan, no internal data is updated, and ALU/IIR readback be determined by RDFILT. Read only.

CELL6REG (0x4C)

CELLn is a read-accessible register that holds the current value for each individual cell-measurement result.

BIT	15	14	13	12	11	10	9	8
Field	CELL6[13:6]							
Reset	0x0000							
Access Type	Read Only							
BIT	7	6	5	4	3	2	1	0
Field	CELL6[5:0]						–	–
Reset	0x0000						–	–
Access Type	Read Only						–	–

BITFIELD	BITS	DESCRIPTION
CELL6	15:2	Cell-Voltage-Measurement Result: CELLn[13:0] contains the 14-bit measurement result for CELLn. Full-scale input range of 5V. If CELLEN = 0, and the measurement was skipped during the latest ADC scan, no internal data is updated, and ALU/IIR readback be determined by RDFILT. Read only.

CELL7REG ((0x4D))

CELLn is a read-accessible register that holds the current value for each individual cell-measurement result.

BIT	15	14	13	12	11	10	9	8
Field	CELL7[13:6]							
Reset	0x0000							
Access Type	Read Only							
BIT	7	6	5	4	3	2	1	0
Field	CELL7[5:0]						–	–
Reset	0x0000						–	–
Access Type	Read Only						–	–

BITFIELD	BITS	DESCRIPTION
CELL7	15:2	Cell-Voltage-Measurement Result: CELLn[13:0] contains the 14-bit measurement result for CELLn. Full-scale input range of 5V. If CELLEN = 0, and the measurement was skipped during the latest ADC scan, no internal data is updated, and ALU/IIR readback be determined by RDFILT. Read only.

CELL8REG (0x4E)

CELLn is a read-accessible register that holds the current value for each individual cell-measurement result.

BIT	15	14	13	12	11	10	9	8
Field	CELL8[13:6]							
Reset	0x0000							
Access Type	Read Only							
BIT	7	6	5	4	3	2	1	0
Field	CELL8[5:0]						–	–
Reset	0x0000						–	–
Access Type	Read Only						–	–

BITFIELD	BITS	DESCRIPTION
CELL8	15:2	Cell-Voltage-Measurement Result: CELLn[13:0] contains the 14-bit measurement result for CELLn. Full-scale input range of 5V. If CELLEN=0, and the measurement was skipped during the latest ADC scan, no internal data is updated, and ALU/IIR readback be determined by RDFILT. Read only.

CELL9REG (0x4F)

CELLn is a read-accessible register that holds the current value for each individual cell-measurement result.

BIT	15	14	13	12	11	10	9	8
Field	CELL9[13:6]							
Reset	0x0000							
Access Type	Read Only							
BIT	7	6	5	4	3	2	1	0
Field	CELL9[5:0]						–	–
Reset	0x0000						–	–
Access Type	Read Only						–	–

BITFIELD	BITS	DESCRIPTION
CELL9	15:2	Cell-Voltage-Measurement Result: CELLn[13:0] contains the 14-bit measurement result for CELLn. Full-scale input range of 5V. If CELLEN = 0, and the measurement was skipped during the latest ADC scan, no internal data is updated, and ALU/IIR readback be determined by RDFILT. Read only.

CELL10REG (0x50)

CELLn is a read-accessible register that holds the current value for each individual cell-measurement result.

BIT	15	14	13	12	11	10	9	8
Field	CELL10[13:6]							
Reset	0x0000							
Access Type	Read Only							
BIT	7	6	5	4	3	2	1	0
Field	CELL10[5:0]						–	–
Reset	0x0000						–	–
Access Type	Read Only						–	–

BITFIELD	BITS	DESCRIPTION
CELL10	15:2	Cell-Voltage-Measurement Result: CELLn[13:0] contains the 14-bit measurement result for CELLn. Full-scale input range of 5V. If CELLEN = 0, and the measurement was skipped during the latest ADC Scan, no internal data is updated, and ALU/IIR readback be determined by RDFILT. Read only.

CELL11REG (0x51)

CELLn is a read-accessible register that holds the current value for each individual cell-measurement result.

BIT	15	14	13	12	11	10	9	8
Field	CELL11[13:6]							
Reset	0x0000							
Access Type	Read Only							
BIT	7	6	5	4	3	2	1	0
Field	CELL11[5:0]						–	–
Reset	0x0000						–	–
Access Type	Read Only						–	–

BITFIELD	BITS	DESCRIPTION
CELL11	15:2	Cell-Voltage-Measurement Result: CELLn[13:0] contains the 14-bit measurement result for CELLn. Full-scale input range of 5V If CELLEN = 0, and the measurement was skipped during the latest ADC scan, no internal data is updated, and ALU/IIR readback be determined by RDFILT. Read only.

CELL12REG (0x52)

CELLn is a read-accessible register that holds the current value for each individual cell-measurement result.

BIT	15	14	13	12	11	10	9	8
Field	CELL12[13:6]							
Reset	0x0000							
Access Type	Read Only							
BIT	7	6	5	4	3	2	1	0
Field	CELL12[5:0]						–	–
Reset	0x0000						–	–
Access Type	Read Only						–	–

BITFIELD	BITS	DESCRIPTION
CELL12	15:2	Cell-Voltage-Measurement Result: CELLn[13:0] contains the 14-bit measurement result for CELLn. Full-scale input range of 5V If CELLEN = 0, and the measurement was skipped during the latest ADC scan, no internal data is updated, and ALU/IIR readback be determined by RDFILT. Read only.

CELL13REG (0x53)

CELLn is a read-accessible register that holds the current value for each individual cell-measurement result.

BIT	15	14	13	12	11	10	9	8
Field	CELL13[13:6]							
Reset	0x0000							
Access Type	Read Only							
BIT	7	6	5	4	3	2	1	0
Field	CELL13[5:0]						–	–
Reset	0x0000						–	–
Access Type	Read Only						–	–

BITFIELD	BITS	DESCRIPTION
CELL13	15:2	Cell-Voltage-Measurement Result: CELLn[13:0] contains the 14-bit measurement result for CELLn. Full-scale input range of 5V. If CELLEN = 0, and the measurement was skipped during the latest ADC scan, no internal data is updated, and ALU/IIR readback be determined by RDFILT. Read only.

CELL14REG (0x54)

CELLn is a read-accessible register that holds the current value for each individual cell measurement result.

BIT	15	14	13	12	11	10	9	8
Field	CELL14[13:6]							
Reset	0x0000							
Access Type	Read Only							
BIT	7	6	5	4	3	2	1	0
Field	CELL14[5:0]						–	–
Reset	0x0000						–	–
Access Type	Read Only						–	–

BITFIELD	BITS	DESCRIPTION
CELL14	15:2	Cell-Voltage-Measurement Result: CELLn[13:0] contains the 14-bit measurement result for CELLn. Full-scale input range of 5V. If CELLEN = 0, and the measurement was skipped during the latest ADC scan, no internal data is updated, and ALU/IIR readback be determined by RDFILT. Read only.

BLOCKREG (0x55)

BLOCK is a read-accessible register that holds the current value for the total block-measurement result.

BIT	15	14	13	12	11	10	9	8
Field	VBLOCK[13:6]							
Reset	0x0000							
Access Type	Read Only							
BIT	7	6	5	4	3	2	1	0
Field	VBLOCK[5:0]						–	–
Reset	0x0000						–	–

Access Type	Read Only		-	-
BITFIELD	BITS	DESCRIPTION		
VBLOCK	15:2	Block-Voltage-Measurement Result: VBLOCK[13:0] contains the 14-bit measurement result for VBLK. Full-scale input range of 65V. If BLOCKEN = 0, and the measurement was skipped during the latest ADC scan, no internal data is updated, and ALU/IIR readback be determined by RDFILT. Read only.		

TOTALREG (0x56)

TOTAL is a read-accessible register that holds the current value for the sum of all enabled-measurement results within the stack.

BIT	15	14	13	12	11	10	9	8
Field	TOTAL[15:8]							
Reset	0x0000							
Access Type	Read Only							
BIT	7	6	5	4	3	2	1	0
Field	TOTAL[7:0]							
Reset	0x0000							
Access Type	Read Only							

BITFIELD	BITS	DESCRIPTION
TOTAL	15:0	Total Cell-Voltage-Measurement Result: TOTAL[15:0] contains the 16-bit sum of all cell-measurement results enabled during the last scan by MEASUREEN1. Full-scale range is 0.0 to 80.0V with a 1.22mV LSB (unipolar). Read only. Note: Make note of the following behavior: Since disabled measurements retain their last results, it is possible there be data in the result registers that were not included in the TOTAL result calculated for the last scan. If cell and bus bar (unipolar and bipolar) measurements are mixed within a scan, the summation be handled accordingly. Totals below 0V cannot be supported, and be clipped at 0x0000 (can apply to scans using only bipolar measurements).

DIAG1REG (0x57)

DIAG1 is a read-only register that contains the diagnostic result requested by the DIAGCFG:DIAGSEL1 selection taken during the last ADC acquisition.

BIT	15	14	13	12	11	10	9	8
Field	DIAG1[13:6]							

Reset	0x0000							
Access Type	Read Only							
BIT	7	6	5	4	3	2	1	0
Field	DIAG1[5:0]						–	–
Reset	0x0000						–	–
Access Type	Read Only						–	–

BITFIELD	BITS	DESCRIPTION
DIAG1	15:2	DIAG1 contains the 14-bit measurement result for the diagnostic selected by DIAGCFG:DIAGSEL1.

DIAG2REG (0x58)

DIAG2 is a read-only register that contains the diagnostic result requested by the DIAGCFG:DIAGSEL2 selection taken during the last ADC acquisition.

BIT	15	14	13	12	11	10	9	8
Field	DIAG2[13:6]							
Reset	0x0000							
Access Type	Read Only							
BIT	7	6	5	4	3	2	1	0
Field	DIAG2[5:0]						–	–
Reset	0x0000						–	–
Access Type	Read Only						–	–

BITFIELD	BITS	DESCRIPTION
DIAG2	15:2	DIAG2 contains the 14-bit measurement result for the diagnostic selected by DIAGCFG:DIAGSEL2.

AUX0REG (0x59)

AUXn is a read-accessible register that holds the current value for each enabled individual auxiliary-measurement result.

BIT	15	14	13	12	11	10	9	8
Field	AUX0[13:6]							
Reset	0x0000							
Access Type	Read Only							
BIT	7	6	5	4	3	2	1	0
Field	AUX0[5:0]						–	–
Reset	0x0000						–	–

Access Type	Read Only		-	-
BITFIELD	BITS	DESCRIPTION		
AUX0	15:2	Auxiliary-Voltage-Measurement Result: AUXn[13:0] contains the 14-bit measurement result for AUXn. Full-scale input range of V_{AA} for ratiometric operation, V_{REF} for absolute operation. If the port is not configured as an AUXINn input (see AUXGPIOCFG), the result readback 0x0000 for the unused channel; otherwise, if AUXEN = 0 and the measurement was skipped during the latest ADC Scan, the previously determined result remain. Read only.		

AUX1REG (0x5A)

AUXn is a read-accessible register that holds the current value for each enabled individual auxiliary-measurement result.

BIT	15	14	13	12	11	10	9	8
Field	AUX1[13:6]							
Reset	0x0000							
Access Type	Read Only							
BIT	7	6	5	4	3	2	1	0
Field	AUX1[5:0]						-	-
Reset	0x0000						-	-
Access Type	Read Only						-	-

BITFIELD	BITS	DESCRIPTION		
AUX1	15:2	Auxiliary-Voltage-Measurement Result: AUXn[13:0] contains the 14-bit measurement result for AUXn. Full-scale input range of V_{AA} for ratiometric operation, V_{REF} for absolute operation. If the port is not configured as an AUXINn input (see AUXGPIOCFG), the result readback 0x0000 for the unused channel; otherwise, if AUXEN = 0 and the measurement was skipped during the latest ADC scan, the previously determined result remain. Read only.		

AUX2REG (0x5B)

AUXn is a read-accessible register that holds the current value for each enabled individual auxiliary-measurement result.

BIT	15	14	13	12	11	10	9	8
Field	AUX2[13:6]							
Reset	0x0000							
Access Type	Read Only							
BIT	7	6	5	4	3	2	1	0

Field	AUX2[5:0]	–	–
Reset	0x0000	–	–
Access Type	Read Only	–	–

BITFIELD	BITS	DESCRIPTION
AUX2	15:2	<p>Auxiliary-Voltage-Measurement Result: AUXn[13:0] contains the 14-bit measurement result for AUXn. Full-scale input range of V_{AA} for ratiometric operation, V_{REF} for absolute operation. If the port is not configured as an AUXINn input (see AUXGPIOCFG), the result readback 0x0000 for the unused channel; otherwise, if AUXEN = 0 and the measurement was skipped during the latest ADC scan, the previously determined result remain. Read only.</p>

AUX3REG (0x5C)

AUXn is a read-accessible register that holds the current value for each enabled individual auxiliary-measurement result.

BIT	15	14	13	12	11	10	9	8	
Field	AUX3[13:6]								
Reset	0x0000								
Access Type	Read Only								
BIT	7	6	5	4	3	2	1	0	
Field	AUX3[5:0]							–	–
Reset	0x0000							–	–
Access Type	Read Only							–	–

BITFIELD	BITS	DESCRIPTION
AUX3	15:2	<p>Auxiliary--Voltage-Measurement Result: AUXn[13:0] contains the 14-bit measurement result for AUXn. Full-scale input range of V_{AA} for ratiometric operation, V_{REF} for absolute operation. If the port is not configured as an AUXINn input (see AUXGPIOCFG), the result readback 0x0000 for the unused channel.; otherwise, if AUXEN = 0 and the measurement was skipped during the latest ADC scan, the previously determined result remain. Read only.</p>

AUX4REG (0x5D)

AUXn is a read-accessible register that holds the current value for each enabled individual auxiliary-measurement result.

BIT	15	14	13	12	11	10	9	8
Field	AUX4[13:6]							
Reset	0x0000							
Access Type	Read Only							

BIT	7	6	5	4	3	2	1	0
Field	AUX4[5:0]						–	–
Reset	0x0000						–	–
Access Type	Read Only						–	–

BITFIELD	BITS	DESCRIPTION
AUX4	15:2	<p>Auxiliary-Voltage-Measurement Result: AUXn[13:0] contains the 14-bit measurement result for AUXn. Full-scale input range of V_{AA} for ratiometric operation, V_{REF} for absolute operation If the port is not configured as an AUXINn input (see AUXGPIOCFG), the result readback 0x0000 for the unused channel; otherwise, if AUXEN = 0 and the measurement was skipped during the latest ADC scan, the previously determined result remain. Read only.</p>

AUX5REG (0x5E)

AUXn is a read-accessible register that holds the current value for each enabled individual auxiliary-measurement result.

BIT	15	14	13	12	11	10	9	8
Field	AUX5[13:6]							
Reset	0x0000							
Access Type	Read Only							

BIT	7	6	5	4	3	2	1	0
Field	AUX5[5:0]						–	–
Reset	0x0000						–	–
Access Type	Read Only						–	–

BITFIELD	BITS	DESCRIPTION
AUX5	15:2	<p>Auxiliary-Voltage-Measurement Result: AUXn[13:0] contains the 14-bit measurement result for AUXn. Full-scale input range of V_{AA} for ratiometric operation, V_{REF} for absolute operation. If the port is not configured as an AUXINn input (see AUXGPIOCFG), the result readback 0x0000 for the unused channel; otherwise, if AUXEN = 0 and the measurement was skipped during the latest ADC scan, the previously determined result remain. Read only.</p>

POLARITYCTRL (0x5F)

POLARITYCTRL is a read-/write-accessible register that governs the measurement type used during scans. In general, unipolar mode indicates a cell and bipolar mode indicates a bus bar.

BIT	15	14	13	12	11	10	9	8
Field	MINMAX-POL	–	POLARITY[14:9]					
Reset	0b0	–	0x0000					
Access Type	Write, Read	–	Write, Read					
BIT	7	6	5	4	3	2	1	0
Field	POLARITY[8:1]							
Reset	0x0000							
Access Type	Write, Read							

BITFIELD	BITS	DESCRIPTION
MINMAXPOL	15	<p>MIN/MAX Operating Mode: 0 = Only unipolar cell measurements are included in MINCELL, MAXCELL, and ALRTMSMTCH calculations (default). 1 = Only bipolar cell measurements are included in MINCELL, MAXCELL, and ALRTMSMTCH calculations (useful in fuel cell applications).</p>
POLARITY	13:0	<p>Cell-Measurement Polarity Selection: 0 = Unipolar 0 to 5V input range (default) 1 = Bipolar -2.5V to +2.5V input</p> <p>Bipolar cells are fault masked during BALSWDIAG ADC measurement scans. MINMAXPOL determines whether bipolar cells are included in MIN/MAXCELL and ALRTMSMTCH calculations.</p> <p>Bipolar cell measurements are checked against BIPOVTH and BIPUVTH thresholds, rather than OVTH and UVTH thresholds.</p> <p>Bipolar cells are not included in comparator-measurement scans: ALRTCOMPOV, ALRTCOMPUV alerts are not triggered.</p>

AUXREFCTRL (0x60)

AUXREFCTRL is a read-/write-accessible register that governs the reference range used for enabled auxiliary channels during ADC and COMP acquisition sequences.

BIT	15	14	13	12	11	10	9	8
Field	–	–	–	–	–	–	–	–
Reset	–	–	–	–	–	–	–	–
Access Type	–	–	–	–	–	–	–	–
BIT	7	6	5	4	3	2	1	0
Field	–	–	AUXREFSEL[5:4]		AUXREFSEL[3:0]			
Reset	–	–	0x0		0x0			
Access Type	–	–	Write, Read, Ext		Write, Read, Ext			

BITFIELD	BITS	DESCRIPTION
AUXREFSEL	5:4	<p>Auxiliary-Input-Reference Selection: 0 = Ratiometric, REF = V_{THRM} (default) 1 = Absolute, REF = V_{REF} = 2.307V</p> <p>This bit selects the reference used and which set of AUX OV, UV, and OPN thresholds are used during ADC and comparator-acquisition sequences.</p> <p>Note: If the respective GPIOEN bit is set (GPIO mode), this bit is ignored, but still reads back the user setting.</p>
AUXREFSEL	3:0	<p>Auxiliary-Input-Reference Selection: 0 = Ratiometric, REF = V_{THRM} (default) 1 = Absolute, REF = V_{REF} = 2.307V</p> <p>This bit selects the reference used and which set of AUX OV, UV, and OPN thresholds are used during ADC and comparator-acquisition sequences.</p> <p>Note: If the respective GPIOEN bit is set (GPIO mode), this bit is ignored, but still reads back the user setting.</p>

AUXTIMEREG (0x61)

AUXTIMEREG is a read-/write-accessible register that governs the settling time allowed for biasing AUX/GPIO pins prior to measurements.

BIT	15	14	13	12	11	10	9	8
Field	–	–	–	–	–	–	AUXTIME[9:8]	
Reset	–	–	–	–	–	–	0x000	
Access Type	–	–	–	–	–	–	Write, Read	
BIT	7	6	5	4	3	2	1	0
Field	AUXTIME[7:0]							
Reset	0x000							
Access Type	Write, Read							

BITFIELD	BITS	DESCRIPTION
AUXTIME	9:0	<p>Auxiliary Pre-Conversion-Settling Time: Configures the preconversion settling time for all enabled AUXn inputs from 0µs (default) up to 6.138ms according to the equation: $t_{SETTLE} = (AUXTIME[9:0]) \times 6\mu s$ This is to allow extra settling time if the application circuit requires it since the THRM voltage is not driven out until the start of the acquisition (in auto mode). This time is inserted at the beginning of each requested scan. If AUXTIME has not expired, but no other scan measurement is active, the HVCP be refreshed during the AUXTIME.</p>

ACQCFG (0x62)

ACQCFG is a read-/write-accessible register that governs several aspects of the measurement and acquisition procedure.

BIT	15	14	13	12	11	10	9	8
Field	ADCZSF-SEN	ADCCALEN	COMPACCEN	FOSR[1:0]		THRMMODE[1:0]		–
Reset	0b0	0b0	0b0	0b00		0b00		–
Access Type	Write, Read	Write, Read	Write, Read	Write, Read		Write, Read		–
BIT	7	6	5	4	3	2	1	0
Field	–	–	–	–	–	–	–	–
Reset	–	–	–	–	–	–	–	–
Access Type	–	–	–	–	–	–	–	–

BITFIELD	BITS	DESCRIPTION
ADCZSFSEN	15	<p>End-of-Sequence ADC Stuck-At-Fault Diagnostic Enable: 0 = Disable ADC ZS/FS diagnostics (default) 1 = Enable ADC ZS/FS diagnostics If enabled, at the end of any measurement sequence using the ADC (SCANCFG ! = 010), the ADC is automatically tested with overdriven inputs designed to force outputs to zero scale and full scale. Any result other than 0x000 or 0xFF is reported through ALRTADCZS and ALRTADCF, respectively.</p>
ADCCALEN	14	<p>ADC Calibration Enable: 0 = Calibration not applied to scan results 1 = Calibration applied to scan results Note: Does not impact comparator operations.</p>
COMPACCEN	13	<p>End-of-Sequence Comparator Accuracy Diagnostic Enable: 0 = Disable COMPACC diagnostics (default) 1 = Enable COMPACC diagnostics If enabled, at the end of any measurement sequence using the comparator (SCANCFG = 001 or 010), the comparator automatically be tested with COMP_{IN} = V_{REF} through the LSA2 path (gain = 6/13) and DAC_{REF} = V_{REF} against bracketing thresholds COMPACCOVTHR and COMPACCUVTHR. If an unexpected result is found, ALRTCOMPACCOV or ALRTCOMPACCUV be issued.</p>
FOSR	12:11	<p>Oversampling Frequency Selection: 00 = f_{OSR} = Frequency determined by selected features 01 = f_{OSR} = 1.60kHz, useful for 50Hz rejection 1x = f_{OSR} = 1.92kHz, useful for 60Hz rejection For ADC and comparator scans, F_{OSR} sets a specific effective sampling frequency for use with oversampled acquisitions (OVSAMPL > 000). This can be used to place nulls at n x (f_{OSR}/OSR) to help reject noise at a given frequency. For example, with f_{OSR} = 1.60kHz and OSR = 32, noise at 50Hz and its harmonics can be attenuated. Selection 00 results in an arbitrary but maximum effective sampling frequency determined solely by the number of channels and diagnostics selected for measurement, in addition to analog overhead operations (HVCP refresh, etc.). Worst case is estimated at 2.2kHz with all features enabled.</p>

BITFIELD	BITS	DESCRIPTION
THRMMODE	10:9	Thermistor Bias Control Mode: Controls application of V_{AA} to the THRM pin through the internal switch, to bias external thermistors for measurement. 0x = Automatic mode (switch ON during acquisition mode) 10 = Manual off mode (switch always OFF) 11 = Manual on mode (switch always ON)

BALSWDLY (0x63)

BALSWDLY is a read-/write-accessible register that selects the delay intervals used within manual and automated cell-balancing operations when ADC measurements are requested.

BIT	15	14	13	12	11	10	9	8
Field	CELLDLY[7:0]							
Reset	0x00							
Access Type	Write, Read							
BIT	7	6	5	4	3	2	1	0
Field	SWDLY[7:0]							
Reset	0x00							
Access Type	Write, Read							

BITFIELD	BITS	DESCRIPTION
CELLDLY	15:8	Cell-Balancing Cell-Path Recovery-Delay Selection: Time delay for C[n] (HVMUX) recovery from voltage drop during cell balancing prior to ADC measurement. Values of 0 μ s (default) to 24.480ms can be realized (96 μ s step size). This delay is used in manual Cell-Balancing modes when using AUTOBALSWDIS = 1 and ALTMUXSEL = 0. Also used in automatic cell balancing and Discharge modes after each pair of even and odd discharge cycles when CBMEASEN = 1x and ALTMUXSEL = 0.
SWDLY	7:0	Cell-Balancing Switch-Path Recovery-Delay Selection: Time delay for SW[n] (ALTMUX) recovery from voltage drop during cell balancing prior to ADC Measurement. Values of 0 μ s (default) to 24.480ms can be realized (96 μ s step size). This delay is used in manual Cell-Balancing modes when using AUTOBALSWDIS = 1 and ALTMUXSEL = 1. Also used in automatic cell balancing and discharge modes after each pair of even and odd discharge cycles when CBMEASEN = 1x and ALTMUXSEL = 1.

MEASUREEN1 (0x64)

MEASUREEN1 is a read-/write-accessible register that governs the channels measured during ADC and COMP acquisition sequences.

BIT	15	14	13	12	11	10	9	8
Field	–	BLOCKEN	CELLEN[14:9]					
Reset	–	0b0	0x0000					
Access Type	–	Write, Read	Write, Read					
BIT	7	6	5	4	3	2	1	0
Field	CELLEN[8:1]							
Reset	0x0000							
Access Type	Write, Read							

BITFIELD	BITS	DESCRIPTION
BLOCKEN	14	<p>Block-Voltage-Measurement Enable: 0 = Disable VBLK/TOPBLOCK measurement and automatic divider connection (default) 1 = Enable VBLK/TOPBLOCK measurement and automatic divider connection Applies to ADC scans only; block is not subject to comparator measurements. In addition to enabling the ADC measurement, BLOCKEN automatically engage the VBLOCK resistive divider for the duration of the scan. Note: In FLXPCKEN1/2 applications (FLXPCKEN = 1), the resistive divider is connected to a selected Cn pin, and the resulting bias current impact the Cn result. Therefore, in Flex Pack applications, it is generally recommended to set BLOCKEN = 1 only for scans with ALTMUXSEL = 1.</p>
CELLEN	13:0	<p>Cell-Voltage-Measurement Enable: 0 = Disable CELLn measurement (default) 1 = Enable CELLn measurement Enables measurement of the respective cell in the acquisition mode.</p>

MEASUREEN2 (0x65)

MEASUREEN2 is a read-/write-accessible register that governs the auxiliary channels measured during ADC and COMP acquisition sequences, as well as IIR initialization.

BIT	15	14	13	12	11	10	9	8
Field	SCANI-IRINIT	–	–	–	–	–	–	–
Reset	0b0	–	–	–	–	–	–	–
Access Type	Write, Read	–	–	–	–	–	–	–
BIT	7	6	5	4	3	2	1	0
Field	–	–	AUXEN[5:4]		AUXEN[3:0]			
Reset	–	–	0x0		0x0			
Access Type	–	–	Write, Read, Ext		Write, Read, Ext			

BITFIELD	BITS	DESCRIPTION
SCANIIRINIT	15	<p>Sequencer IIR Initialization Request: 0 = IIR filter continuation (default) 1 = IIR filter initialized</p> <p>In continuation mode, the current value in the IIR accumulators is kept (presumably from previous cell measurements) and sequencer measurements are amended normally.</p> <p>In Initialization mode, the IIR accumulators be reinitialized to the first measurement taken, and further cell-balancing measurements are amended normally.</p>
AUXEN	5:4	<p>Auxiliary-Input-Measurement Enable: 0 = Auxiliary ADC measurement disabled (default) 1 = Auxiliary ADC measurement enabled</p> <p>Enables measurement of the respective auxiliary inputs in acquisition mode.</p> <p>Note: If the respective GPIOEN bit is set (GPIO mode), this bit is ignored, but still reads back the user setting.</p>
AUXEN	3:0	<p>Auxiliary-Input-Measurement Enable: 0 = Auxiliary ADC measurement disabled (default) 1 = Auxiliary ADC measurement enabled</p> <p>Enables measurement of the respective auxiliary inputs in acquisition mode.</p> <p>Note: If the respective GPIOEN bit is set (GPIO mode), this bit is ignored, but still reads back the user setting.</p>

SCANCTRL (0x66)

SCANCTRL is a read-/write-accessible register that governs the internal measurement acquisitions (scan) requested of the device. The register also manages the handling of data generated as a result of any scan request.

ADC Scans are used for precision measurements of cell and auxiliary voltages.

COMP Scans are used for periodic safety/redundancy checking of ADC results, and in some cases, enhanced communication efficiency.

On Demand Calibration run an internal calibration of the ADC and update the Calibration Data Registers. All ADC measurements requested by Scan and Diagnostic Configuration and Control settings be ignored.

Balance Switch and Cell Sense Wire Open ADC Diagnostic Scans are a special class of ADC Scan. Use of these settings temporarily override other Scan and Diagnostic Configuration and Control settings. See BALSWS and Cell Sense Wire Open Diagnostics for details.

BIT	15	14	13	12	11	10	9	8
Field	SCAN-DONE	SCANTIME-OUT	DATARDY	AUTO-BALSWDIS	ALRTFILT-SEL	AMENDFILT	RDFILT	SCAN-CFG[2]
Reset	0b0	0b0	0b0	0b0	0b0	0b0	0b0	0b000
Access Type	Write 0 to Clear, Read	Write 0 to Clear, Read	Write, Read, Ext	Write, Read	Write, Read	Write, Read	Write, Read	Write, Read
BIT	7	6	5	4	3	2	1	0
Field	SCANCFG[1:0]		OVSAMPL[2:0]			ALTMUX-SEL	SCAN-MODE	SCAN
Reset	0b000		0b000			0b0	0b0	0b0
Access Type	Write, Read		Write, Read			Write, Read	Write, Read	Write, Read, Pulse

BITFIELD	BITS	DESCRIPTION
SCANDONE	15	<p>Acquisition-Complete-Indicator Bit: 0 = Indicates a SCAN acquisition is in progress if requested 1 = Indicates the SCAN acquisition has completed Once a SCAN acquisition has completed, the device set this bit high to indicate completion. This bit is cleared by writing to zero. When this bit is high, further acquisitions requested using SCAN are ignored. Writing to logic one has no internal effect.</p>
SCANTIMEOUT	14	<p>Scan-Timeout-Indicator Bit: Indicates the acquisition did not complete in the expected period of time. The timeout threshold depends on the oversampling configuration. If a SCANTIMEOUT is issued, the resulting partial data should be treated as suspect and ignored. In applications using the IIR, SCANIIRINIT should be issued to avoid any corruption resulting from the timeout event. The acquisition watchdog can be disabled by setting SCANTODIS in the DEVCFG2 register. Cleared by writing to logic zero to allow detection of future timeout events. Writing to logic one has no internal effect.</p>
DATARDY	13	<p>Data-Ready Indicator Bit: Indicates the measurement data from the acquisition has been transferred from the ALU to the data registers and may now be read. Data for all measurement registers and MIN/MAX/TOTAL is transferred at the same time. Cleared by writing to logic zero to allow detection of the next data transfer. Writing to logic one has no internal effect.</p>
AUTOBALSWDIS	12	<p>Automatic Balancing-Switch Disable: 0 = Cell-balance operations not impacted by measurement sequences (default) 1 = Cell-balance manual operations temporarily disabled during measurement sequences Enables automatic suspension of active manual cell-balancing operations during measurement sequences. The delay for cell-recovery settling time and for the diagnostic recovery is selected automatically based on the ALTMUXSEL setting for the sequence as follows: 0 = CELLDLY is used 1 = SWDLY is used</p>
ALRTFILSEL	11	<p>Alert-Filtering Selection: 0 = Alert issuance based on raw sequencer results (default) 1 = Alert issuance based on IIR filter results Determines whether the cell and block alerts are issued based on raw sequencer outputs (oversampling still applies) or IIR filtered outputs. If mode 1 is selected, MEASUREEN2:SCANIIRINIT should be used with the first scan to avoid triggering false alerts due to the IIR settling behavior. Note: This bit is ignored for measurement scans taken in automated Cell-Balancing modes (ALRTFILSEL = 1 is used).</p>

BITFIELD	BITS	DESCRIPTION
AMENDFILT	10	<p>Amend-IIR Filter Enable: 0 = ADC result is not included in the IIR accumulator (default) 1 = ADC result is included in the IIR accumulator</p> <p>When set high, for ADC outputs that have IIR filters/accumulators, the new ADC conversion in the ALU is automatically scaled and transferred into the IIR accumulator at the end of the sequence. This is often used for normal-measurement sequences.</p> <p>When set low, the new ADC conversion in the ALU is not transferred into the IIR accumulator at the end of the sequence. This is often used for diagnostic-measurement sequences where the ADC result would corrupt the settled normal data.</p> <p>Note: This bit is ignored for measurement scans taken in automated Cell-Balancing modes (AMENDFILT = 1 is used).</p>
RDFILT	9	<p>Read-IIR Filter Selection: 0 = Unfiltered ADC data is loaded into the output data registers (default) 1 = Filtered ADC data is loaded into the output data registers</p> <p>This bit chooses the source for data loaded to the CELLnREG and BLOCKREG registers for read back. The setting of this bit at the time of a measurement scan request (SCAN = 1) also determines the source data (filtered/unfiltered) used for TOTAL, MINCELL, MAXCELL, MSMTCH, and all OV/UV alert computations.</p>
SCANCFG	8:6	<p>Scan Configuration: Selects the type of scan to be performed based on the selections below. FOSR selection applies to all scans where oversampling applies.</p> <p>000 = ADC-only scan 001 = ADC+COMP scan (Pyramid only) 010 = COMP-only scan (Pyramid only) 011 = On-demand calibration 100 = Balancing switch short 101 = Balancing switch open 110 = Cell sense open odds 111 = Cell sense open evens</p> <p>Some of these selections are formatted by other register content. Some selections temporarily modify/override other register content. See register descriptions for further details.</p> <p>For COMP scans, polarity is always defaulted to unipolar; any cell measurements requested in bipolar mode are skipped.</p> <p>On-demand calibration executes an automated routine that updates the contents of the CALOSADC, CALOSR, CALOSTHRM, CALGAINP, and CALGAINR correction coefficients. No other measurements are taken during this operation.</p> <p>Note: This bitfield is ignored for measurement scans taken in automated Cell-Balancing modes (SCANCFG = 000 is used).</p>

BITFIELD	BITS	DESCRIPTION
OVSAMPL	5:3	<p>Oversampling Selection for ADC Acquisitions: 000 = Single acquisition 001 = 4x oversampling 010 = 8x oversampling 011 = 16x oversampling 100 = 32x oversampling 101 = 64x oversampling 11x = 128x oversampling</p> <p>Note: This bitfield is ignored during calibration (SCANCFG = 011) scans. This bitfield is ignored for measurement scans taken in automated cell-balancing modes (OVSAMPL = 011 is used).</p>
ALTMUXSEL	2	<p>Cell-Measurement Path Selection: 0 = HVMUX signal path (default) 1 = ALTMUX signal path See the <i>Diagnostics</i> section.</p> <p>Note: Where ALTMUX settings disagree with SCANCFG (BALSWDIAG), SCANCFG takes precedence.</p>
SCANMODE	1	<p>ADC-Scan Mode Selection: 0 = Pyramid scan mode (default) 1 = Ramp scan mode</p> <p>Ramp scan mode is not supported for scans using the comparator or calibration scan requests (the setting is ignored in these modes).</p> <p>Note: This bit is ignored for measurement scans taken in automated Cell-Balancing modes (SCANMODE = 0 is used).</p>
SCAN	0	<p>Scan (Measurement Sequence) Request: 0 = Used to initiate a data transfer and/or set up measurement conditions without initiating a measurement sequence 1 = Used to request a new measurement sequence (scan) and initiate a data transfer</p> <p>Acts as a strobe bit and therefore does not need to be cleared (self-clearing). Always reads logic zero. Writes to SCANCTRL with SCAN = 1 requesting new scans are ignored if a scan is already in progress, or if SCANDONE is high. In this case, the content written to SCANCTRL[15:1] is accepted but the conflicting scan will not be executed and ALRTRJCT be issued, notifying the user of the conflict.</p> <p>Note: The intended use of this bit is to enter/exit BALSWDIAG modes using SCANCFG, and allow the alternate conditions to settle prior to requesting the measurement (with a subsequent write to SCANCTRL with SCAN = 1). This bit can also be used to realize a variety of data-move options (see DBLBUFEN and RDFILT for details), or to clear SCANDONE, SCANTIMEOUT, and DATARDY bits without requesting a measurement sequence/scan.</p>

ADCTEST1AREG (0x67)

ADCTEST1A is a read-/write-accessible register that contains user-specified arguments used in ALU diagnostics.

BIT	15	14	13	12	11	10	9	8
Field	ADCTSTEN	–	–	–	ADCTEST1A[11:8]			
Reset	0b0	–	–	–	0x000			
Access Type	Write, Read	–	–	–	Write, Read			

BIT	7	6	5	4	3	2	1	0
Field	ADCTEST1A[7:0]							
Reset	0x000							
Access Type	Write, Read							

BITFIELD	BITS	DESCRIPTION
ADCTSTEN	15	<p>ADC/ALU Self-Test Mode Enable: 0 = Normal operation (default) 1 = Enables the ALU test mode This mode feeds 12-bit data from the ADCTEST registers directly into the ALU instead of the ADC-conversion data. Scans can then be performed, confirming proper operation of the ALU and calibration MAC. Notes: No calibration coefficients are applied to ensure deterministic results (gain = 1.0, offset = 0.0). ADCTESTEN is ignored for on-demand calibration scans (SCANCFG = 011) to avoid miscalibration, and all scans performed during automated Cell-Balancing modes to avoid inaccurate balancing results.</p>
ADCTEST1A	11:0	<p>ALU ADC Input Argument 1A: User-specified test data for the ALU diagnostic (ADCTESTEN = 1). This 12-bit data is fed into the ALU during the first conversion of odd-numbered samples (e.g., first sample).</p>

ADCTEST1BREG (0x68)

ADCTEST1B is a read-/write-accessible register that contains user-specified arguments used in ALU diagnostics.

BIT	15	14	13	12	11	10	9	8
Field	–	–	–	–	ADCTEST1B[11:8]			
Reset	–	–	–	–	0x000			
Access Type	–	–	–	–	Write, Read			

BIT	7	6	5	4	3	2	1	0
Field	ADCTEST1B[7:0]							
Reset	0x000							
Access Type	Write, Read							

BITFIELD	BITS	DESCRIPTION
ADCTEST1B	11:0	<p>ALU ADC Input Argument 1B: User-specified test data for the ALU diagnostic (ADCTEST = 1). This 12-bit data is fed into the ALU during the second conversion of odd-numbered samples (e.g., first sample).</p>

ADCTEST2AREG (0x69)

ADCTEST2A is a read-/write-accessible register that contains user-specified arguments used in ALU diagnostics.

BIT	15	14	13	12	11	10	9	8
Field	–	–	–	–	ADCTEST2A[11:8]			
Reset	–	–	–	–	0x000			
Access Type	–	–	–	–	Write, Read			
BIT	7	6	5	4	3	2	1	0
Field	ADCTEST2A[7:0]							
Reset	0x000							
Access Type	Write, Read							

BITFIELD	BITS	DESCRIPTION
ADCTEST2A	11:0	ALU ADC Input Argument 2A: User-specified test data for the ALU diagnostic (ADCTEST = 1). This 12-bit data is fed into the ALU during the first conversion of even-numbered samples in oversampling mode.

ADCTEST2BREG (0x6A)

ADCTEST2B is a read-/write-accessible register that contains user-specified arguments used in ALU diagnostics.

BIT	15	14	13	12	11	10	9	8
Field	–	–	–	–	ADCTEST2B[11:8]			
Reset	–	–	–	–	0x000			
Access Type	–	–	–	–	Write, Read			
BIT	7	6	5	4	3	2	1	0
Field	ADCTEST2B[7:0]							
Reset	0x000							
Access Type	Write, Read							

BITFIELD	BITS	DESCRIPTION
ADCTEST2B	11:0	ALU ADC Input Argument 2B: User-specified test data for the ALU diagnostic (ADCTEST = 1). This 12-bit data is fed into the ALU during the second conversion of even-numbered samples in oversampling mode.

DIAGCFG (0x6B)

DIAGCFG is a read-/write-accessible register that governs diagnostic source and mode options applied to the internal measurement acquisitions (scans).

BIT	15	14	13	12	11	10	9	8
Field	CTSTDAC[3:0]				CTSTSRC	MUXDIAG-BUS	MUXDIAG-PAIR	MUXDIAGEN
Reset	0x0				0b0	0b0	0b0	0b0
Access Type	Write, Read				Write, Read	Write, Read	Write, Read	Write, Read
BIT	7	6	5	4	3	2	1	0
Field	DIAGSEL2[3:0]				DIAGSEL1[3:0]			
Reset	0x0				0x0			
Access Type	Write, Read				Write, Read			

BITFIELD	BITS	DESCRIPTION																											
CTSTDAC	15:12	Current-Level Configuration for All Enabled Test Sources: Per the table below (6.25µA LSB for Cn, AUXIN, 3.125µA LSB for HVMUX)																											
		<table border="1"> <thead> <tr> <th>CTSTDAC</th> <th>TEST SOURCE</th> <th>CURRENT</th> </tr> </thead> <tbody> <tr> <td>[3:0]</td> <td>Cn, AUXIN</td> <td>HVMUX</td> </tr> <tr> <td>0x0</td> <td>6.25µA</td> <td>3.125µA</td> </tr> <tr> <td>0x1</td> <td>12.50µA</td> <td>6.250µA</td> </tr> <tr> <td>0x2</td> <td>18.75µA</td> <td>9.375µA</td> </tr> <tr> <td>...</td> <td>...</td> <td>...</td> </tr> <tr> <td>0xD</td> <td>87.5µA</td> <td>43.75µA</td> </tr> <tr> <td>0xE</td> <td>93.75µA</td> <td>46.875µA</td> </tr> <tr> <td>0xF</td> <td>100µA</td> <td>50µA</td> </tr> </tbody> </table>	CTSTDAC	TEST SOURCE	CURRENT	[3:0]	Cn, AUXIN	HVMUX	0x0	6.25µA	3.125µA	0x1	12.50µA	6.250µA	0x2	18.75µA	9.375µA	0xD	87.5µA	43.75µA	0xE	93.75µA	46.875µA	0xF	100µA	50µA
		CTSTDAC	TEST SOURCE	CURRENT																									
		[3:0]	Cn, AUXIN	HVMUX																									
		0x0	6.25µA	3.125µA																									
		0x1	12.50µA	6.250µA																									
		0x2	18.75µA	9.375µA																									
																										
		0xD	87.5µA	43.75µA																									
0xE	93.75µA	46.875µA																											
0xF	100µA	50µA																											
CTSTSRC	11	Test Current-Source Polarity: 0 = Sink current to GND (default) 1 = Source current from V _{AA} Note: Polarity selection applies to AUX test current sources only.																											
MUXDIAGBUS	10	Selects the HVMUX output to which the HVMUX test current source is connected, if MUXDIAGPAIR is enabled: 0 = Output used for even cells, C0, and AGND 1 = Output used for odd cells, REF, and ALTREF																											
MUXDIAGPAIR	9	MUX Diagnostic Bus Configuration: 0 = Both HVMUX test-current sources are connected to both HVMUX outputs (default) 1 = A single HVMUX test-current source is connected to only one HVMUX output (as selected by MUXDIAGBUS)																											
MUXDIAGEN	8	HVMUX Test-Current Source(s) Enable: 0 = Disable (default) 1 = Enable The current level is configured by CSTDAC and the connectivity is configured by MUXDIAGPAIR and MUXDIAGBUS																											

BITFIELD	BITS	DESCRIPTION
DIAGSEL2	7:4	<p>Acquisition Diagnostic2-Measurement Selection: 0000 = No diagnostic requested 0001 = Die temperature ($ADC_{IN} = V_{PTAT}$, $ADC_{REF} = V_{REF}$) 0010 = V_{AA} ($ADC_{IN} = V_{REF}$ through LSamp, $ADC_{REF} = V_{AA}$) 0011 = Cell signal-path ADC fault, V_{ALTREF} ($ADC_{IN} = V_{ALTREF}$ through LSamp, $ADC_{REF} = V_{REF}$) 0100 = Comparator-cell signal-path fault ($ADC_{IN} = V_{REF}$ through LSamp2 - V_{DAC} at $DAC_{CODE} = 0x1D8$ (6/13), $ADC_{REF} = DAC_{REF} = V_{REF}$, bipolar mode) 0101 = Cell calibration ($ADC_{IN} = V_{REF}$ through LSamp, $ADC_{REF} = V_{REF}$), calibration gain and offset coefficients and chopping applied according to SCANMODE selection. 0110 = Offset calibration ($ADC_{IN} = \text{Short}$ (Pyramid) or $ADC_{IN} = \text{Short}$ through LSamp (Ramp), $ADC_{REF} = V_{REF}$, bipolar mode), calibration offset coefficients applied according to SCANMODE selection. 0111 = 3/4-scale DAC test ($DAC = 0x2FF$ $ADC_{IN} = V_{DAC}$, $ADC_{REF} = DAC_{REF} = V_{REF}$). 1000 = 1/4-scale DAC test ($DAC = 0x100$ $ADC_{IN} = V_{DAC}$, $ADC_{REF} = DAC_{REF} = V_{REF}$). 1001 = THRM offset calibration ($ADC_{IN} = \text{Short}$, $ADC_{REF} = V_{THRM}$, bipolar mode), CALOSTHRM coefficient applied.</p> <p>Selects the second diagnostic measurement appended to the acquisition, with the result stored in DIAG2. Appropriate calibrations (or factory defaults if ADCALEN = 0) and chopping are applied as needed.</p> <p>Detailed Diagnostics: 1010 = Zero-scale ADC test (0x0000, $ADC_{IN} = -V_{AA}$, $ADC_{REF} = V_{REF}$, bipolar mode), full result available through DIAG. 1011 = Full-scale ADC test (0x3FFC, $ADC_{IN} = V_{AA}$, $ADC_{REF} = V_{REF}$, bipolar mode), full result available through DIAG. 1100 = LSAMP offset ($ADC_{IN} = V_{LSA_0V}$, $ADC_{REF} = V_{REF}$, bipolar mode) Detailed diagnostics are normally performed at the end of an acquisition (with the exception of LSAMP offset, which is covered by the V_{ALTREF} diagnostic), and the pass/fail results are available in the FMEA2 BIST alerts; however, if necessary to examine detailed results, these can be made available in the DIAG2 register using the modes above.</p>

BITFIELD	BITS	DESCRIPTION
DIAGSEL1	3:0	<p>Acquisition Diagnostic1-Measurement Selection: 0000 = No diagnostic requested 0001 = Die temperature ($ADC_{IN} = V_{PTAT}$, $ADC_{REF} = V_{REF}$) 0010 = V_{AA} ($ADC_{IN} = V_{REF}$ through LSamp, $ADC_{REF} = V_{AA}$) 0011 = Cell signal-path ADC fault, V_{ALTREF} ($ADC_{IN} = V_{ALTREF}$ through LSamp, $ADC_{REF} = V_{REF}$) 0100 = Comparator-cell signal-path fault ($ADC_{IN} = V_{REF}$ through LSamp2 - V_{DAC} at $DAC_{CODE} = 0x1D8$ (6/13), $ADC_{REF} = DAC_{REF}$ V_{REF}, bipolar mode) 0101 = Cell calibration ($ADC_{IN} = V_{REF}$ through LSamp, $ADC_{REF} = V_{REF}$). Calibration gain and offset coefficients and chopping applied according to SCANMODE selection. 0110 = Offset calibration ($ADC_{IN} = Short$ (Pyramid) or $ADC_{IN} = Short$ through LSamp (ramp), $ADC_{REF} = V_{REF}$, bipolar mode). Calibration offset coefficients applied according to SCANMODE selection. 0111 = 3/4-scale DAC test ($DAC = 0x2FF$, $ADC_{IN} = V_{DAC}$, $ADC_{REF} = DAC_{REF} = V_{REF}$) 1000 = 1/4-scale DAC test ($DAC = 0x100$, $ADC_{IN} = V_{DAC}$, $ADC_{REF} = DAC_{REF} = V_{REF}$) 1001 = THRM offset calibration ($ADC_{IN} = short$, $ADC_{REF} = V_{THRM}$, bipolar mode) CALOSTHRM coefficient applied. Selects the first diagnostic measurement appended to the acquisition, with the result stored in DIAG1. Appropriate calibrations (or factory defaults if ADCALEN = 0) and chopping are applied as needed.</p> <p>Detailed Diagnostics: 1010 = Zero-scale ADC test ($0x0000$, $ADC_{IN} = -V_{AA}$, $ADC_{REF} = V_{REF}$, bipolar mode), full result available through DIAG 1011 = Full-scale ADC test ($0x3FFC$, $ADC_{IN} = V_{AA}$, $ADC_{REF} = V_{REF}$, bipolar mode), full result available through DIAG 1100 = LSAMP offset ($ADC_{IN} = V_{LSA_0V}$, $ADC_{REF} = V_{REF}$, bipolar mode) Detailed diagnostics are normally performed at the end of an acquisition (with the exception of LSAMP offset, which is covered by the V_{ALTREF} diagnostic), and the pass/fail results are available in the FMEA2 BIST alerts; however, if it is necessary to examine detailed results, these can be made available in the DIAG1 register using the modes above.</p>

CTSTCFG (0x6C)

CTSTCFG is a read-/write-accessible register that controls the application of diagnostic current sources to selected cell input channels.

BIT	15	14	13	12	11	10	9	8
Field	CEL- LOPNDIAG- SEL	CTSTEN[14:8]						
Reset	0b0	0x0000						
Access Type	Write, Read	Write, Read						
BIT	7	6	5	4	3	2	1	0
Field	CTSTEN[7:0]							
Reset	0x0000							
Access Type	Write, Read							

BITFIELD	BITS	DESCRIPTION
CELLOPNDIAGSEL	15	<p>Cell Open-Diagnostic-Mode Selection: 0 = Normal operation (default) 1 = Open-diagnostic operation</p> <p>In normal mode (0), measured CELLn channels are selected by CELLEN and measured with standard thresholds on a per-channel basis for both ADC and comparator-acquisition sequences.</p> <p>In open-diagnostic mode (1), measured CELLn channels are selected by (CELLENn & IPOLARITYn), on a per-channel basis. Only low-side comparator checks are performed using alternate-open (OPN) thresholds.</p> <p>Normally, in open-diagnostic modes, pulldown current sources are enabled on all measured channels using CTSTEN, and only comparator measurements are selected (SCANCFG = 010).</p> <p>This mode is most often used with an appropriate auxiliary open-diagnostic mode (AUXDIAGSEL = 010 or 011).</p>
CTSTEN	14:0	<p>Cell Diagnostic-Current-Source Enable: Enables the current sources connected to the corresponding cell inputs for diagnostic testing. The current level is configured by the CTSTDAC in the DIAGCFG register.</p>

AUXSTCFG (0x6D)

AUXSTCFG is a read-/write-accessible register that controls the application of diagnostic modes and current sources to selected auxiliary input channels.

BIT	15	14	13	12	11	10	9	8
Field	–	–	–	–	–	–	–	–
Reset	–	–	–	–	–	–	–	–
Access Type	–	–	–	–	–	–	–	–

BIT	7	6	5	4	3	2	1	0
Field	–	–	AUXSTEN[5:4]		AUXSTEN[3:0]			
Reset	–	–	0x0		0x0			
Access Type	–	–	Write, Read, Ext		Write, Read, Ext			

BITFIELD	BITS	DESCRIPTION
AUXSTEN	5:4	<p>Auxiliary-Diagnostic Current-Source Enable: Enables the current source connected to the corresponding auxiliary input for diagnostic testing. The current level is configured by DIAGCFG:CTSTDAC and the current direction is configured by DIAGCFG:CTSTSRC. Note: If the respective GPIOEN bit is set (GPIO mode), this bit is ignored but still reads back the user setting.</p>
AUXSTEN	3:0	<p>Auxiliary-Diagnostic Current-Source Enable: Enables the current sources connected to the corresponding auxiliary input for diagnostic testing. The current level is configured by DIAGCFG:CTSTDAC and the current direction is configured by DIAGCFG:CTSTSRC. Note: If the respective GPIOEN bit is set (GPIO mode), this bit is ignored, but still reads back the user setting.</p>

DIAGGENCFG (0x6E)

DIAGGENCFG is a read-/write-accessible register that controls the application of general diagnostic modes to the selected auxiliary input paths.

BIT	15	14	13	12	11	10	9	8
Field	AUXDIAGSEL[2:0]			–	–	–	–	–
Reset	0b000			–	–	–	–	–
Access Type	Write, Read			–	–	–	–	–

BIT	7	6	5	4	3	2	1	0
Field	–	–	–	–	–	–	–	–
Reset	–	–	–	–	–	–	–	–
Access Type	–	–	–	–	–	–	–	–

BITFIELD	BITS	DESCRIPTION
AUXDIAGSEL	15:13	AUX Diagnostic Mode Selection: 00x = Normal operation (default) 010 = AUX accelerated discharge operation (ratio metric only) 011 = THRM output connected to AGND 100 = Reserved for Maxim Use Only 101 = Reserved for Maxim Use Only 110 = Reserved for Maxim Use Only 111 = Reserved for Maxim Use Only Control bits used for AUXINn pin diagnostic testing. Only to ports configured as AUX inputs are tested.

BALSWCTRL (0x6F)

BALSWCTRL is a read/write-accessible register that governs the behavior of the charge-balancing switches in manual and automated cell-balancing modes.

Write access to this register is blocked during automated cell-balancing operations (CBMODE = 001, 1xx).

BIT	15	14	13	12	11	10	9	8
Field	CBRE-START	–	BALSWEN[14:9]					
Reset	0b0	–	0x0000					
Access Type	Write, Read, Pulse	–	Write, Read, Ext					
BIT	7	6	5	4	3	2	1	0
Field	BALSWEN[8:1]							
Reset	0x0000							
Access Type	Write, Read, Ext							

BITFIELD	BITS	DESCRIPTION
----------	------	-------------

CBRESTART	15	<p>Watchdog Timer Restart for Manual Mode: 0 = CBTIMER continues to run 1 = CBTIMER is reset to zero Acts as a strobe bit and therefore does not need to be cleared. Always reads logic zero. Accessible and applies in manual mode only. Writing 1 to CBRESTART after cell-balancing timer expiration has no effect. To perform another manual-mode cell-balancing event, user must issue a separate write to the BALCTRL register.</p>
BALSWEN	13:0	<p>Balance-Switch Enable: BALSWEN[n] enables the balancing switch (allowing conduction) between SWn and SWn-1, balancing CELLn.</p>

BALEXP1 (0x70)

BALEXPn is a read-/write-accessible register that holds the cell-balancing expiration time for CELLn (using the switch across SWn and SWn-1).

BALEXP1 sets the expiration time for all group automated cell-balancing and discharge modes and the watchdog time-out for manual cell-balancing mode.

Write access to this register is blocked during all cell-balancing operations (CBMODE! = 000).

BIT	15	14	13	12	11	10	9	8
Field	–	–	–	–	–	–	CBEXP1[9:8]	
Reset	–	–	–	–	–	–	0x000	
Access Type	–	–	–	–	–	–	Write, Read, Ext	
BIT	7	6	5	4	3	2	1	0
Field	CBEXP1[7:0]							
Reset	0x000							
Access Type	Write, Read, Ext							

BITFIELD	BITS	DESCRIPTION
CBEXP1	9:0	<p>Cell Balancing Expiration Time: Cell-balancing expiration time for CELLn; unit (LSB = hour, minute, or second) determined by CBMODE. CBEXP1 is used as the master/watchdog timeout setting for manual, discharge, and automated group Cell-Balancing modes. Value 0x3FF operates balancing indefinitely (no timer expiration). Default value 0x000 disables cell balancing (preconfigured timer expiration).</p>

BALEXP2 (0x71)

BALEXP2 is a read-/write-accessible register that holds the cell-balancing expiration time for CELL_n (using the switch across SW_n and SW_{n-1}). Used in individual Auto Cell-Balancing modes only.

Write access to this register is blocked during automated cell-balancing operations (CBMODE = 1xx).

BIT	15	14	13	12	11	10	9	8
Field	–	–	–	–	–	–	CBEXP2[9:8]	
Reset	–	–	–	–	–	–	0x000	
Access Type	–	–	–	–	–	–	Write, Read, Ext	
BIT	7	6	5	4	3	2	1	0
Field	CBEXP2[7:0]							
Reset	0x000							
Access Type	Write, Read, Ext							

BITFIELD	BITS	DESCRIPTION
CBEXP2	9:0	Cell-Balancing Expiration Time: Cell-balancing expiration time for CELL _n ; unit (LSB = hour, minute, or second) determined by CBMODE. Value 0x3FF operates balancing indefinitely (no timer expiration). Default value 0x000 disables cell balancing (preconfigured timer expiration).

BALEXP3 (0x72)

BALEXP3 is a read-/write-accessible register that holds the cell-balancing expiration time for CELL_n (using the switch across SW_n and SW_{n-1}). Used in individual auto Cell-Balancing modes only.

Write access to this register is blocked during automated cell-balancing operations (CBMODE = 1xx).

BIT	15	14	13	12	11	10	9	8
Field	–	–	–	–	–	–	CBEXP3[9:8]	
Reset	–	–	–	–	–	–	0x000	
Access Type	–	–	–	–	–	–	Write, Read, Ext	
BIT	7	6	5	4	3	2	1	0
Field	CBEXP3[7:0]							
Reset	0x000							
Access Type	Write, Read, Ext							

BITFIELD	BITS	DESCRIPTION
CBEXP3	9:0	Cell-Balancing Expiration Time: Cell-balancing expiration time for CELL _n ; unit (LSB = hour, minute, or second) determined by CBMODE. Value 0x3FF operates balancing indefinitely (no timer expiration). Default value 0x000 disables cell balancing (preconfigured timer expiration).

BALEXP4 (0x73)

BALEXP4 is a read-/write-accessible register that holds the cell-balancing expiration time for CELLn (using the switch across SWn and SWn-1). Used in individual automated Cell-Balancing modes only.

Write access to this register is blocked during automated cell-balancing operations (CBMODE = 1xx).

BIT	15	14	13	12	11	10	9	8
Field	–	–	–	–	–	–	CBEXP4[9:8]	
Reset	–	–	–	–	–	–	0x000	
Access Type	–	–	–	–	–	–	Write, Read, Ext	
BIT	7	6	5	4	3	2	1	0
Field	CBEXP4[7:0]							
Reset	0x000							
Access Type	Write, Read, Ext							

BITFIELD	BITS	DESCRIPTION
CBEXP4	9:0	Cell-Balancing Expiration Time: Cell-balancing expiration time for CELLn; unit (LSB = hour, minute, or second) determined by CBMODE. Value 0x3FF operates balancing indefinitely (no timer expiration). Default value 0x000 disables cell balancing (preconfigured timer expiration).

BALEXP5 (0x74)

BALEXP5 is a read-/write-accessible register that holds the Cell-Balancing-Expiration Time for CELLn (using the switch across SWn and SWn-1). Used in Individual Auto-Cell Balancing modes only.

Write access to this register is blocked during Automated Cell-Balancing operations (CBMODE = 1xx).

BIT	15	14	13	12	11	10	9	8
Field	–	–	–	–	–	–	CBEXP5[9:8]	
Reset	–	–	–	–	–	–	0x000	
Access Type	–	–	–	–	–	–	Write, Read, Ext	
BIT	7	6	5	4	3	2	1	0
Field	CBEXP5[7:0]							
Reset	0x000							
Access Type	Write, Read, Ext							

BITFIELD	BITS	DESCRIPTION
CBEXP5	9:0	Cell-Balancing Expiration Time: Cell-balancing expiration time for CELLn; unit (LSB = hour, minute, or second) determined by CBMODE. Value 0x3FF operates balancing indefinitely (no timer expiration). Default value 0x000 disables cell balancing (preconfigured timer expiration).

BALEXP6 (0x75)

BALEXP6 is a read-/write-accessible register that holds the Cell-Balancing Expiration Time for CELLn (using the switch across SWn and SWn-1). Used in Individual Automated Cell-Balancing modes only.

Write access to this register is blocked during Automated Cell-Balancing operations (CBMODE = 1xx).

BIT	15	14	13	12	11	10	9	8
Field	–	–	–	–	–	–	CBEXP6[9:8]	
Reset	–	–	–	–	–	–	0x000	
Access Type	–	–	–	–	–	–	Write, Read, Ext	
BIT	7	6	5	4	3	2	1	0
Field	CBEXP6[7:0]							
Reset	0x000							
Access Type	Write, Read, Ext							

BITFIELD	BITS	DESCRIPTION
CBEXP6	9:0	Cell-Balancing Expiration Time: Cell-balancing expiration time for CELLn; unit (LSB = hour, minute, or second) determined by CBMODE. Value 0x3FF operates balancing indefinitely (no timer expiration). Default value 0x000 disables cell balancing (preconfigured timer expiration).

BALEXP7 (0x76)

BALEXP7 is a read-/write-accessible register that holds the Cell-Balancing Expiration Time for CELLn (using the switch across SWn and SWn-1). Used in Individual Automated Cell-Balancing modes only.

Write access to this register is blocked during Automated Cell-Balancing operations (CBMODE = 1xx).

BIT	15	14	13	12	11	10	9	8
Field	–	–	–	–	–	–	CBEXP7[9:8]	
Reset	–	–	–	–	–	–	0x000	
Access Type	–	–	–	–	–	–	Write, Read, Ext	
BIT	7	6	5	4	3	2	1	0
Field	CBEXP7[7:0]							
Reset	0x000							
Access Type	Write, Read, Ext							

BITFIELD	BITS	DESCRIPTION
CBEXP7	9:0	Cell-Balancing Expiration Time: Cell-balancing expiration time for CELLn; unit (LSB = hour, minute, or second) determined by CBMODE. Value 0x3FF operates balancing indefinitely (no timer expiration). Default value 0x000 disables cell balancing (preconfigured timer expiration).

BALEXP8 (0x77)

BALEXP8 is a read-/write-accessible register that holds the Cell-Balancing Expiration Time for CELLn (using the switch across SWn and SWn-1). Used in Individual Automated Cell-Balancing modes only.

Write access to this register is blocked during Automated Cell-Balancing operations (CBMODE = 1xx).

BIT	15	14	13	12	11	10	9	8
Field	–	–	–	–	–	–	CBEXP8[9:8]	
Reset	–	–	–	–	–	–	0x000	
Access Type	–	–	–	–	–	–	Write, Read, Ext	
BIT	7	6	5	4	3	2	1	0
Field	CBEXP8[7:0]							
Reset	0x000							
Access Type	Write, Read, Ext							

BITFIELD	BITS	DESCRIPTION
CBEXP8	9:0	Cell-Balancing Expiration Time: Cell-balancing expiration time for CELLn; unit (LSB = hour, minute, or second) determined by CBMODE. Value 0x3FF operates balancing indefinitely (no timer expiration). Default value 0x000 disables cell balancing (preconfigured timer expiration).

BALEXP9 (0x78)

BALEXP9 is a read-/write-accessible register that holds the Cell-Balancing Expiration Time for CELLn (using the switch across SWn and SWn-1). Used in Individual Automated Cell-Balancing modes only.

Write access to this register is blocked during Automated Cell-Balancing operations (CBMODE = 1xx).

BIT	15	14	13	12	11	10	9	8
Field	–	–	–	–	–	–	CBEXP9[9:8]	
Reset	–	–	–	–	–	–	0x000	
Access Type	–	–	–	–	–	–	Write, Read, Ext	
BIT	7	6	5	4	3	2	1	0
Field	CBEXP9[7:0]							
Reset	0x000							
Access Type	Write, Read, Ext							

BITFIELD	BITS	DESCRIPTION
CBEXP9	9:0	Cell-Balancing Expiration Time: Cell-balancing expiration time for CELLn; unit (LSB = hour, minute, or second) determined by CBMODE. Value 0x3FF operates balancing indefinitely (no timer expiration). Default value 0x000 disables cell balancing (preconfigured timer expiration).

BALEXP10 (0x79)

BALEXP10 is a read-/write-accessible register that holds the Cell-Balancing Expiration Time for CELLn (using the switch across SWn and SWn-1). Used in Individual Automated Cell-Balancing modes only.

Write access to this register is blocked during Automated Cell Balancing operations (CBMODE = 1xx).

BIT	15	14	13	12	11	10	9	8
Field	–	–	–	–	–	–	CBEXP10[9:8]	
Reset	–	–	–	–	–	–	0x000	
Access Type	–	–	–	–	–	–	Write, Read, Ext	
BIT	7	6	5	4	3	2	1	0
Field	CBEXP10[7:0]							
Reset	0x000							
Access Type	Write, Read, Ext							

BITFIELD	BITS	DESCRIPTION
CBEXP10	9:0	Cell-Balancing Expiration Time: Cell-balancing expiration time for CELLn; unit (LSB = hour, minute, or second) determined by CBMODE. Value 0x3FF operates balancing indefinitely (no timer expiration). Default value 0x000 disables cell balancing (preconfigured timer expiration).

BALEXP11 (0x7A)

BALEXP11 is a read-/write-accessible register that holds the Cell-Balancing Expiration Time for CELLn (using the switch across SWn and SWn-1). Used in Individual Automated Cell-Balancing modes only.

Write access to this register is blocked during Automated Cell-Balancing operations (CBMODE = 1xx).

BIT	15	14	13	12	11	10	9	8
Field	–	–	–	–	–	–	CBEXP11[9:8]	
Reset	–	–	–	–	–	–	0x000	
Access Type	–	–	–	–	–	–	Write, Read, Ext	
BIT	7	6	5	4	3	2	1	0
Field	CBEXP11[7:0]							
Reset	0x000							
Access Type	Write, Read, Ext							

BITFIELD	BITS	DESCRIPTION
CBEXP11	9:0	Cell-Balancing Expiration Time: Cell-balancing expiration time for CELLn; unit (LSB = hour, minute, or second) determined by CBMODE. Value 0x3FF operates balancing indefinitely (no timer expiration). Default value 0x000 disables cell balancing (preconfigured timer expiration).

BALEXP12 (0x7B)

BALEXP12 is a read-/write-accessible register that holds the Cell-Balancing Expiration Time for CELLn (using the switch across SWn and SWn-1). Used in Individual Automated Cell-Balancing modes only.

Write access to this register is blocked during Automated Cell-Balancing operations (CBMODE = 1xx).

BIT	15	14	13	12	11	10	9	8
Field	–	–	–	–	–	–	CBEXP12[9:8]	
Reset	–	–	–	–	–	–	0x000	
Access Type	–	–	–	–	–	–	Write, Read, Ext	
BIT	7	6	5	4	3	2	1	0
Field	CBEXP12[7:0]							
Reset	0x000							
Access Type	Write, Read, Ext							

BITFIELD	BITS	DESCRIPTION
CBEXP12	9:0	Cell-Balancing Expiration Time: Cell-balancing expiration time for CELLn; unit (LSB = hour, minute, or second) determined by CBMODE. Value 0x3FF operates balancing indefinitely (no timer expiration). Default value 0x000 disables cell balancing (preconfigured timer expiration).

BALEXP13 (0x7C)

BALEXP13 is a read-/write-accessible register that holds the Cell-Balancing Expiration Time for CELLn (using the switch across SWn and SWn-1). Used in Individual Automated Cell-Balancing modes only.

Write access to this register is blocked during Automated Cell-Balancing operations (CBMODE = 1xx).

BIT	15	14	13	12	11	10	9	8
Field	–	–	–	–	–	–	CBEXP13[9:8]	
Reset	–	–	–	–	–	–	0x000	
Access Type	–	–	–	–	–	–	Write, Read, Ext	
BIT	7	6	5	4	3	2	1	0
Field	CBEXP13[7:0]							
Reset	0x000							
Access Type	Write, Read, Ext							

BITFIELD	BITS	DESCRIPTION
CBEXP13	9:0	Cell-Balancing Expiration Time: Cell-balancing expiration time for CELLn; unit (LSB = hour, minute, or second) determined by CBMODE. Value 0x3FF operates balancing indefinitely (no timer expiration). Default value 0x000 disables cell balancing (preconfigured timer expiration).

BALEXP14 (0x7D)

BALEXP14 is a read-/write-accessible register that holds the Cell-Balancing Expiration Time for CELLn (using the switch across SWn and SWn-1). Used in Individual Automated Cell-Balancing modes only.

Write access to this register is blocked during Automated Cell-Balancing operations (CBMODE = 1xx).

BIT	15	14	13	12	11	10	9	8
Field	–	–	–	–	–	–	CBEXP14[9:8]	
Reset	–	–	–	–	–	–	0x000	
Access Type	–	–	–	–	–	–	Write, Read, Ext	
BIT	7	6	5	4	3	2	1	0
Field	CBEXP14[7:0]							
Reset	0x000							
Access Type	Write, Read, Ext							

BITFIELD	BITS	DESCRIPTION
CBEXP14	9:0	Cell-Balancing Expiration Time: Cell-balancing expiration time for CELLn; unit (LSB = hour, minute, or second) determined by CBMODE. Value 0x3FF operates balancing indefinitely (no timer expiration). Default value 0x000 disables cell balancing (preconfigured timer expiration).

BALAUTOVTHR (0x7E)

BALAUTOVTHR is a read-/write-accessible register that selects the cell undervoltage exit threshold for the ADC when used in Automated Cell-Balancing operations.

A write to this register allows direct setting or automatic selection of this threshold.

Write access to this register is blocked during Automated Cell-Balancing operations (CBMODE = 1xx). Also, during active measurement scans, all writes with CBUVMINCELL = 1 will be blocked and result in ALRTRJCT being issued (since the MINCELL data may be altered as a result of the scan in progress).

A read from this register displays the current value of the threshold and the method used for its selection.

BIT	15	14	13	12	11	10	9	8	
Field	CBUVTHR[13:6]								
Reset	0x3FFF								
Access Type	Write, Read, Ext								
BIT	7	6	5	4	3	2	1	0	
Field	CBUVTHR[5:0]						–	CBUVMIN-CELL	
Reset	0x3FFF						–	0b0	
Access Type	Write, Read, Ext						–	Write, Read, Ext	

BITFIELD	BITS	DESCRIPTION
CBUVTHR	15:2	Cell-Balancing Undervoltage Threshold 14-bit ADC threshold, of a 5V input range, below which Cell Balancing Operations are suspended on each CELL. Default of 0x3FFF, ensures no cell balancing occur without prior configuration.
CBUVMINCELL	0	Cell Balancing Undervoltage Threshold Selection 0 = User-Defined CBUVTHR 1 = MINCELL-Defined CBUVTHR In mode 0, the value written to CBUVTHR during a valid write to BALAUTOUVTHR be loaded to CBUVTHR. In mode 1, the current value in the CELLn register corresponding to the MINCELL address be automatically loaded to CBUVTHR during a valid write to BALAUTOUVTHR (and the content in CBUVTHR during the write be ignored). Note: Automated Cell Balancing with CBUVTHR checking is only supported for unipolar cell measurements. If CBUVMINCELL = 1 is written while MINMAXPOL = 1, CBUVTHR be set to 0x3FFF\h as a result.

BALDLYCTRL (0x7F)

BALDLYCTRL is a read-/write-accessible register that selects the delay/timing intervals used within Automated Cell-Balancing operations.

Write access to this register is blocked during Automated Cell-Balancing operations (CBMODE = 001, 1xx).

BIT	15	14	13	12	11	10	9	8
Field	–	–	–	–	–	–	CBNTFYCFG[1:0]	
Reset	–	–	–	–	–	–	0b00	
Access Type	–	–	–	–	–	–	Write, Read, Ext	

BIT	7	6	5	4	3	2	1	0
Field	–	–	–	–	–	CBCALDLY[2:0]		
Reset	–	–	–	–	–	0b000		
Access Type	–	–	–	–	–	Write, Read, Ext		

BITFIELD	BITS	DESCRIPTION
CBNTFYCFG	9:8	Cell-Balancing Notification Alert Configuration: 00 = Disable cell-balancing notification alert (default) 01 = Notification issued every 1 Hr 10 = Notification issued every 2 Hrs 11 = Notification issued every 4 Hrs In automated and discharge modes, the cell-balancing notification alert (ALRTCNTFY) can be issued to confirm normal progression of automated operations. The frequency of issuance is selected as described above, in real time (i.e., not CBDUTY adjusted). Notification alerts continue to be issued during HOLDSHDNL.

BITFIELD	BITS	DESCRIPTION
CBCALDLY	2:0	<p>Cell-Balancing Calibration Period Selection: In automated and discharge modes, after each pair of even and odd cell-balancing periods, a supervisory ADC measurement is taken (and checked against CBUVTHR, if enabled/applicable). CBCALDLY allows a calibration operation to be substituted in place of a measurement at the frequency indicated below. A value of 000 (default) disables CAL operations (only ADC operations are performed). 000 = Periodic calibration disabled 001 = 2 (every other) cycle 010 = 4 (every forth) cycle 011 = 8 cycles 100 = 12 cycles 101 = 16 cycles 110 = 24 cycles 111 = 32 cycles If CBMEASEN = 0x (ADC/CAL measurements disabled), this bitfield is ignored and has no effect.</p>

BALCTRL (0x80)

BALCTRL is a read-/write-accessible register that initiates and controls all internal Cell-Balancing modes and operations.

Any write to this register to a mode other than CBMODE = 000 (disable) restarts the CBTIMER at zero and launches the requested mode of operation.

BIT	15	14	13	12	11	10	9	8
Field	CBACTIVE[1:0]		CBMODE[2:0]			CBIIRINIT	HOLDSHDNL[1:0]	
Reset	0b00		0b000			0b0	0b00	
Access Type	Read Only		Write, Read, Ext			Write, Read	Write, Read	
BIT	7	6	5	4	3	2	1	0
Field	CBDUTY[3:0]				CBDONE-ALRTEN	CBTEMPEN	CBMEASEN[1:0]	
Reset	0x0				0b0	0b0	0x0	
Access Type	Write, Read				Write, Read	Write, Read	Write, Read	

BITFIELD	BITS	DESCRIPTION
CBACTIVE	15:14	<p>Cell Balancing Timer Active Indicator: 00 = Cell balancing is disabled (default) 01 = Cell balancing operations are active 10 = Cell balancing completed normally due to reaching CBUVTHR or CBEXP exit conditions 11 = Cell balancing halted unexpectedly due to thermal exit (ALRTCBTMP), timeout (ALRTCBTIMEOUT), or calibration fault (ALRTCBCAL) conditions Read only.</p>

BITFIELD	BITS	DESCRIPTION
CBMODE	13:11	Cell Balancing Mode Selection 000 = Cell Balancing Disabled (default) 001 = Emergency/EOL Discharge by Hour 010 = Manual Cell Balancing by Second 011 = Manual Cell Balancing by Minute 100 = Auto Individual Cell Balancing by Second 101 = Auto Individual Cell Balancing by Minute 110 = Auto Group Cell Balancing by Second 111 = Auto Group Cell Balancing by Minute
CBIIRINIT	10	Cell Balancing IIR Initialization Request 0 = IIR Filter Continuation (default) 1 = IIR Filter Initialized If enabled, the IIR filter contents be initialized during the first measurement scan and CBUVTHR checks be suspended for 16 measurement scans, giving the IIR time to settle.
HOLDSHDNL	9:8	SHDNL Hold Mode Enable 00 = No Hold (default) 01 = SHDNL Held High for the duration of Automated Cell Balancing or Discharge operation 10 = SHDNL Held High for duration of Automated Cell Balancing or Discharge operations, plus 5 minutes or 6.25% of the maximum applicable CBEXP interval (whichever is greater) 11 = SHDNL Held High for duration of Automated Cell Balancing or Discharge operations, and until removed
CBDUTY	7:4	Cell Balancing Duty Cycle Sets the active duty cycle within each T_{CBEO} period. 0000 = 6.25% (default) 0001 = 12.5% ... 1110 = 93.75% 1111 = 100%, less NOL and Measurement/Calibration overhead.
CBDONEALRTEN	3	Cell Balancing Complete Alert Enable 0 = ALRTCBDONE masked in STATUS1:ALRTCBAL (default) 1 = ALRTCBDONE included in STATUS1:ALRTCBAL Masking of this alert component allows the user the choice to be notified only for unexpected exits, or normal completions as well.
CBTEMPEN	2	Cell Balancing Thermal Exit Enable 0 = Cell Balancing not impacted by ALRTTEMP (default) 1 = Cell Balancing halts in response to ALRTTEMP
CBMEASEN	1:0	Cell Balancing Measurement Enable 0x = Embedded ADC/CAL Measurements and CBUVTHR checking disabled (default) 10 = Embedded ADC/CAL Measurements enabled, CBUVTHR checking disabled 11 = Embedded ADC/CAL Measurements enabled, CBUVTHR checking enabled Note: Automated Cell Balancing with CBUVTHR checking is only supported for unipolar cell measurements.

BALSTAT (0x81)

BALSTAT is a read-accessible register that allows the monitoring of any Automated Cell-Balancing operations currently in progress.

Once a CBMODE is initiated, all status bits persist and are cleared only when CBMODE is written to 000 (disabled) or when a new CBMODE operation is initiated through CBSTART.

BIT	15	14	13	12	11	10	9	8
Field	CBACTIVE_M1[1:0]		CBUNIT[1:0]		CBCNTR[1:0]		CBTIMER[9:8]	
Reset	0b00		0b00		0b00		0x000	
Access Type	Read Only		Read Only		Read Only		Read Only	
BIT	7	6	5	4	3	2	1	0
Field	CBTIMER[7:0]							
Reset	0x000							
Access Type	Read Only							

BITFIELD	BITS	DESCRIPTION
CBACTIVE_M1	15:14	Cell-Balancing Timer Active Indicator (Mirror): 00 = Cell balancing is disabled (default) 01 = Cell balancing operations are active 10 = Cell balancing completed normally due to reaching CBUVTHR or CBEXP exit conditions 11 = Cell balancing halted unexpectedly due to thermal exit (ALRTCBTEMP), Time Out (ALRTCBTIMEOUT), or Calibration Fault (ALRTCBCAL) conditions Read only.
CBUNIT	13:12	Cell-Balancing Timer Unit Indicator: 00 = Cell balancing is disabled (default) 01 = CBTIMER measures Seconds 10 = CBTIMER measures Minutes 11 = CBTIMER measures Hours Allows confirmation of cell-balancing timer operating mode (LSB weight). Read only,
CBCNTR	11:10	Cell-Balancing Active Counter: 1Hz counter that can be read to verify CBTIMER operation/activity when the CBTIMER is operated in minute or hour modes. The counter counts from 0 to 3, rolling over to 0 approximately every 4 seconds in all active Cell-Balancing modes (CBMODE! = 000). Read only. Notes: During Hold SHDNL extension periods (HOLDSHDNL = 1x), CBCNTR continues to run. If the governing CBEXP setting is set to 0x3FF (infinite), this counter continues to run, even though it has no impact on the active Cell-Balancing mode.

BITFIELD	BITS	DESCRIPTION
CBTIMER	9:0	<p>Cell-Balancing Timer Value: Reads the current cell-balancing timer value in seconds, minutes or hours, depending on CBMODE, as indicated by CBUNIT. Read only.</p> <p>Notes: During SHDNL hold/extension periods (HOLDSHDNL = 1x), CBTIMER reads back the governing expiration time (CBEXP), indicating that the requested balancing operation has completed. If the governing CBEXP setting is set to 0x3FF (infinite), this timer still runs and rolls over, even though it has no impact on the active Cell-Balancing mode.</p>

BALUVSTAT (0x82)

BALUVSTAT is a read-accessible register that relates current summary information on the Cell voltages vs. the CBUVTHR undervoltage threshold.

BIT	15	14	13	12	11	10	9	8
Field	CBACTIVE_M2[1:0]		CBUVSTAT[14:9]					
Reset	0b00		0x0000					
Access Type	Read Only		Read Only					
BIT	7	6	5	4	3	2	1	0
Field	CBUVSTAT[8:1]							
Reset	0x0000							
Access Type	Read Only							

BITFIELD	BITS	DESCRIPTION
CBACTIVE_M2	15:14	<p>Cell Balancing Timer Active Indicator (Mirror): 00 = Cell balancing is disabled (default) 01 = Cell-balancing operations are active 10 = Cell balancing completed normally due to reaching CBUVTHR or CBEXP exit conditions 11 = Cell balancing halted unexpectedly due to thermal exit (ALRTCTEMP), timeout (ALRTCBTIMEOUT), or calibration-fault (ALRTCBCAL) conditions Read only.</p>
CBUVSTAT	13:0	<p>Cell-Balance CBUVTHR Check Status: CBUVSTAT[n] = 1 indicates the corresponding CELLn result falls below the threshold specified by CBUVTHR and that cell-balancing operations on that cell have ended. Cleared only when CBMODE is written to 000 (disabled) or when a new CBMODE operation is initiated through a write to BALCTRL. Read only.</p> <p>Note: Automated cell balancing with CBUVTHR checking is only supported for unipolar cell measurements in locations with BALSWEENn = 1. The user must also ensure CELLENn = 1 and POLARITYn = 0 to allow the required measurement updates; if the measurement is not supported, balancing of the cell automatically ends with a CBUVSTATn = 1 exit condition.</p>

BALDATA (0x83)

BALDATA is a read-accessible register that relates current summary information on the Cell voltages vs. the CBUVTHR undervoltage threshold.

BIT	15	14	13	12	11	10	9	8
Field	CBACTIVE_M3[1:0]		DATARDY_M	–	–	–	–	–
Reset	0b00		0b0	–	–	–	–	–
Access Type	Read Only		Write, Read, Ext	–	–	–	–	–
BIT	7	6	5	4	3	2	1	0
Field	–	–	–	–	–	–	–	CBSCAN
Reset	–	–	–	–	–	–	–	0b0
Access Type	–	–	–	–	–	–	–	Write, Read, Pulse

BITFIELD	BITS	DESCRIPTION
CBACTIVE_M3	15:14	<p>Cell-Balancing Timer Active Indicator (Mirror): 00 = Cell balancing is disabled (default) 01 = Cell-balancing operations are active 10 = Cell balancing completed normally due to reaching CBUVTHR or CBEXP exit conditions 11 = Cell balancing halted unexpectedly due to thermal exit (ALRTCBCAL), timeout (ALRTCBCAL), or calibration-fault (ALRTCBCAL) conditions Read only.</p>
DATARDY_M	13	<p>Data-Ready Indicator Bit (Mirror): Indicates the measurement data from the acquisition has been transferred to the data registers and may now be read. Data for all measurement registers and MIN/MAX/TOTAL is transferred at the same time. Cleared by writing to logic zero to allow detection of the next data transfer. Writing to logic one has no internal effect. This is a mirror of the DATARDY bit in SCANCFG, provided to support readback of measurement results taken during automated and discharge Cell-Balancing modes.</p>
CBSCAN	0	<p>Manually Transfer Measurement Results from IIR to Data Registers: 0 = No transfer requested 1 = Measurement transferred from the IIR (regardless of RDFILT setting) to data registers; once transfer is complete, DATARDY bit is set. Acts as a strobe bit and therefore does not need to be cleared (self-clearing). This bit has no effect in cell-balancing manual or disable mode, or when CBMEASEN = 0x. Always reads logic zero.</p>

ID1 (0x8C)

ID1 is a read-accessible register that contains the 2 LSBytes of the unique Device ID stored in ROM and subject to ROMCRC validation.

BIT	15	14	13	12	11	10	9	8
Field	DEVID[15:8]							
Reset								
Access Type	Read Only							
BIT	7	6	5	4	3	2	1	0
Field	DEVID[7:0]							
Reset								
Access Type	Read Only							

BITFIELD	BITS	DESCRIPTION
DEVID	15:0	Device ID (Partial): The two least-significant bytes of the 24-bit factory-programmed device ID. ID1,0 always reads logic one. A valid device ID has two or more bits set to logic one. Read only.

ID2 (0x8D)

ID2 is a read-accessible register that contains the 2 MSBytes of the unique Device ID stored in ROM and subject to ROMCRC validation.

BIT	15	14	13	12	11	10	9	8
Field	DEVID[31:24]							
Reset								
Access Type	Read Only							
BIT	7	6	5	4	3	2	1	0
Field	DEVID[23:16]							
Reset								
Access Type	Read Only							

BITFIELD	BITS	DESCRIPTION
DEVID	15:0	Device ID (Partial): The most-significant byte of the 24-bit factory-programmed device ID. A valid device ID has two or more bits set to logic one. Read only.

OTP2 (0x8E)

Factory-Calibration Data ROM and subject to ROMCRC validation.

BIT	15	14	13	12	11	10	9	8
Field	OTP2[15:8]							
Reset								
Access Type	Read Only							
BIT	7	6	5	4	3	2	1	0
Field	OTP2[7:0]							
Reset								
Access Type	Read Only							

BITFIELD	BITS	DESCRIPTION
OTP2	15:0	Factory-Calibration Data: Read Only.

OTP3 (0x8F)

Factory-Calibration Data ROM and subject to ROMCRC validation.

BIT	15	14	13	12	11	10	9	8
Field	OTP3[15:8]							
Reset								
Access Type	Read Only							
BIT	7	6	5	4	3	2	1	0
Field	OTP3[7:0]							
Reset								
Access Type	Read Only							

BITFIELD	BITS	DESCRIPTION
OTP3	15:0	Factory-Calibration Data: Read Only.

OTP4 (0x90)

Factory-Calibration Data ROM and subject to ROMCRC validation.

BIT	15	14	13	12	11	10	9	8
Field	OTP4[15:8]							
Reset								
Access Type	Read Only							
BIT	7	6	5	4	3	2	1	0
Field	OTP4[7:0]							
Reset								
Access Type	Read Only							

BITFIELD	BITS	DESCRIPTION
OTP4	15:0	Factory-Calibration Data Read Only.

OTP5 (0x91)

Factory-Calibration Data ROM and subject to ROMCRC validation.

BIT	15	14	13	12	11	10	9	8
Field	OTP5[15:8]							
Reset								
Access Type	Read Only							
BIT	7	6	5	4	3	2	1	0
Field	OTP5[7:0]							
Reset								
Access Type	Read Only							

BITFIELD	BITS	DESCRIPTION
OTP5	15:0	Factory-Calibration Data Read Only.

OTP6 (0x92)

Factory-Calibration Data ROM and subject to ROMCRC validation.

BIT	15	14	13	12	11	10	9	8
Field	OTP6[15:8]							
Reset								
Access Type	Read Only							
BIT	7	6	5	4	3	2	1	0
Field	OTP6[7:0]							
Reset								
Access Type	Read Only							

BITFIELD	BITS	DESCRIPTION
OTP6	15:0	Factory-Calibration Data: Read Only.

OTP7 (0x93)

Factory-Calibration Data ROM and subject to ROMCRC validation.

BIT	15	14	13	12	11	10	9	8
Field	OTP7[15:8]							
Reset								
Access Type	Read Only							
BIT	7	6	5	4	3	2	1	0
Field	OTP7[7:0]							
Reset								
Access Type	Read Only							

BITFIELD	BITS	DESCRIPTION
OTP7	15:0	Factory-Calibration Data: Read Only.

OTP8 (0x94)

Factory-Calibration Data ROM and subject to ROMCRC validation.

BIT	15	14	13	12	11	10	9	8
Field	OTP8[15:8]							
Reset								
Access Type	Read Only							
BIT	7	6	5	4	3	2	1	0
Field	OTP8[7:0]							
Reset								
Access Type	Read Only							

BITFIELD	BITS	DESCRIPTION
OTP8	15:0	Factory-Calibration Data Read Only.

OTP9 (0x95)

Factory-Calibration Data ROM and subject to ROMCRC validation.

BIT	15	14	13	12	11	10	9	8
Field	OTP9[15:8]							
Reset								
Access Type	Read Only							
BIT	7	6	5	4	3	2	1	0
Field	OTP9[7:0]							
Reset								
Access Type	Read Only							

BITFIELD	BITS	DESCRIPTION
OTP9	15:0	Factory-Calibration Data Read Only.

OTP10 (0x96)

Factory Calibration Data ROM and subject to ROMCRC validation.

BIT	15	14	13	12	11	10	9	8
Field	OTP10[15:8]							
Reset								
Access Type	Read Only							
BIT	7	6	5	4	3	2	1	0
Field	OTP10[7:0]							
Reset								
Access Type	Read Only							

BITFIELD	BITS	DESCRIPTION
OTP10	15:0	Factory-Calibration Data: Read Only.

OTP11 (0x97)

Factory-Calibration Data ROM and subject to ROMCRC validation.

BIT	15	14	13	12	11	10	9	8
Field	OTP11[15:8]							
Reset								
Access Type	Read Only							
BIT	7	6	5	4	3	2	1	0
Field	OTP11[7:0]							
Reset								
Access Type	Read Only							

BITFIELD	BITS	DESCRIPTION
OTP11	15:0	Factory-Calibration Data: Read Only.

OTP12 (0x98)

Factory-Calibration Data ROM and subject to ROMCRC validation.

BIT	15	14	13	12	11	10	9	8
Field	ROMCRC[7:0]							
Reset								
Access Type	Read Only							
BIT	7	6	5	4	3	2	1	0
Field	OTP12[7:0]							
Reset								
Access Type	Read Only							

BITFIELD	BITS	DESCRIPTION
ROMCRC	15:8	ROM CRC Value: 8-bit CRC value computed from the onboard read-only memory content. ID and OTP ROM output data content is protected by an 8-bit CRC with polynomial 0xA6 ($x^8+x^6+x^3+x^2+1$). Read only.
OTP12	7:0	Factory-Calibration Data: Read Only.

For zero-scale diagnostic: $ADC_{REF} = V_{REF}$ and $ADC_{IN} = -V_{AA}$

If the result from the ADC is greater than 000h, an alert is issued by setting the ALRTADCZS bit in the FMEA2 register.

The DIAGSEL1 and DIAGSEL2 registers can be configured to obtain further diagnostic information regarding the ADC.

Calibration-Alert Diagnostics

To validate the integrity of the calibration, the CALOS ADCCALFRC, CALOSRALRTFRC, CALOSTHRMALRTFRC, CALGAINPALRTFRC, CALGAINRALRTFRC bits can be used to inject an expected overranged input to the digital-calibration circuitry. This sets the corresponding ALRTCALOSADC, ALRTCALOSR, ALRTCALOSTHRM, ALRTCALGAINP, ALRTCALGAINR bit in the ALRTSUM register and demonstrates proper functionality of digital circuitry.

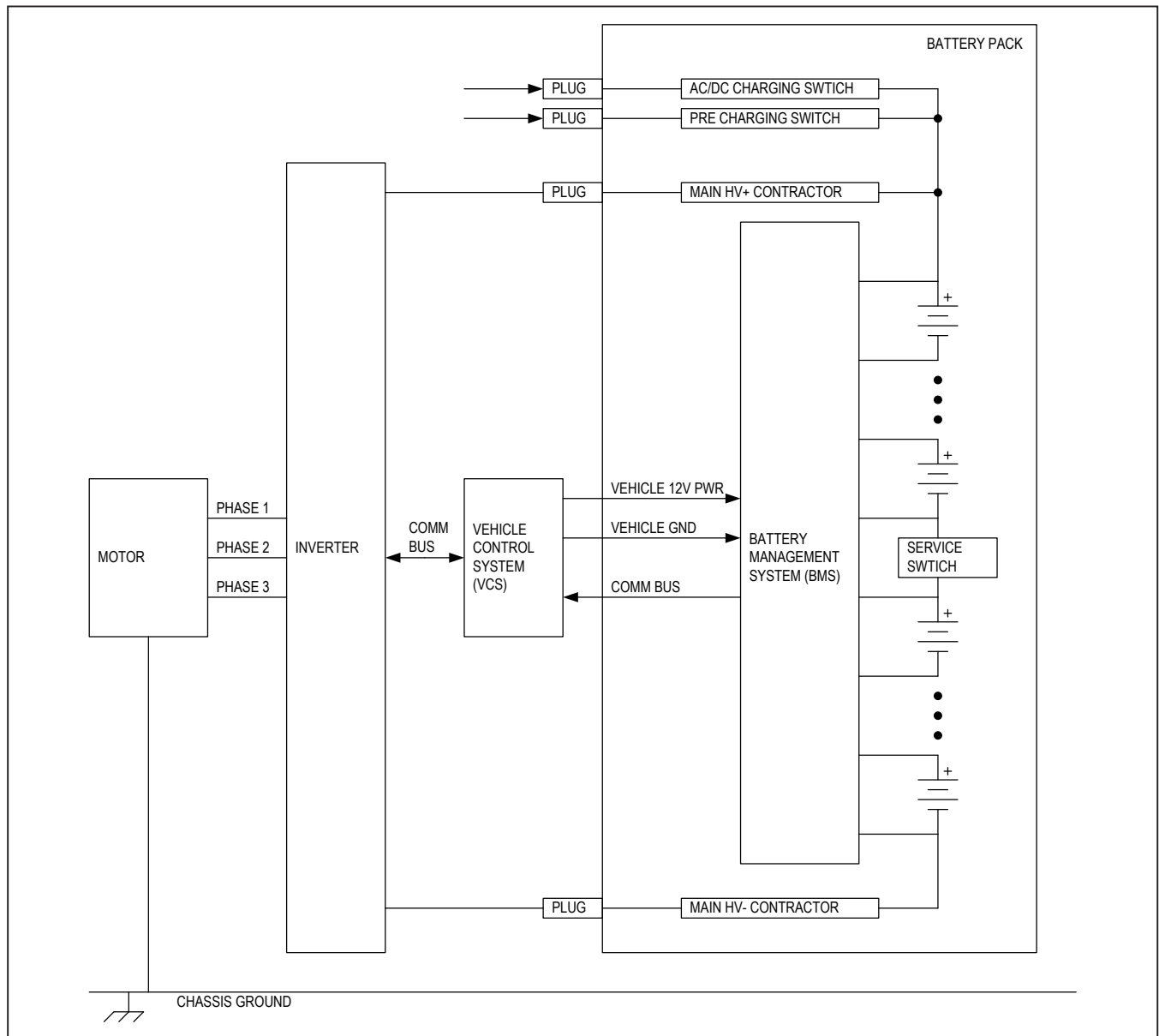

Figure 96. Electric Vehicle System

Note: The analog verification of the calibration is performed using the cell gain-calibration diagnostic, offset-calibration diagnostic, and THRM offset-calibration diagnostic.

Supply Connection Diagnostics

The V_{DDL1} , V_{DDL2} , and V_{DDL3} supply voltages are continuously monitored to be above V_{VDDL_OC} . If a supply goes below the threshold, the ALRTVDDL1, ALRTVDDL2, or ALRTVDDL3 alert is set.

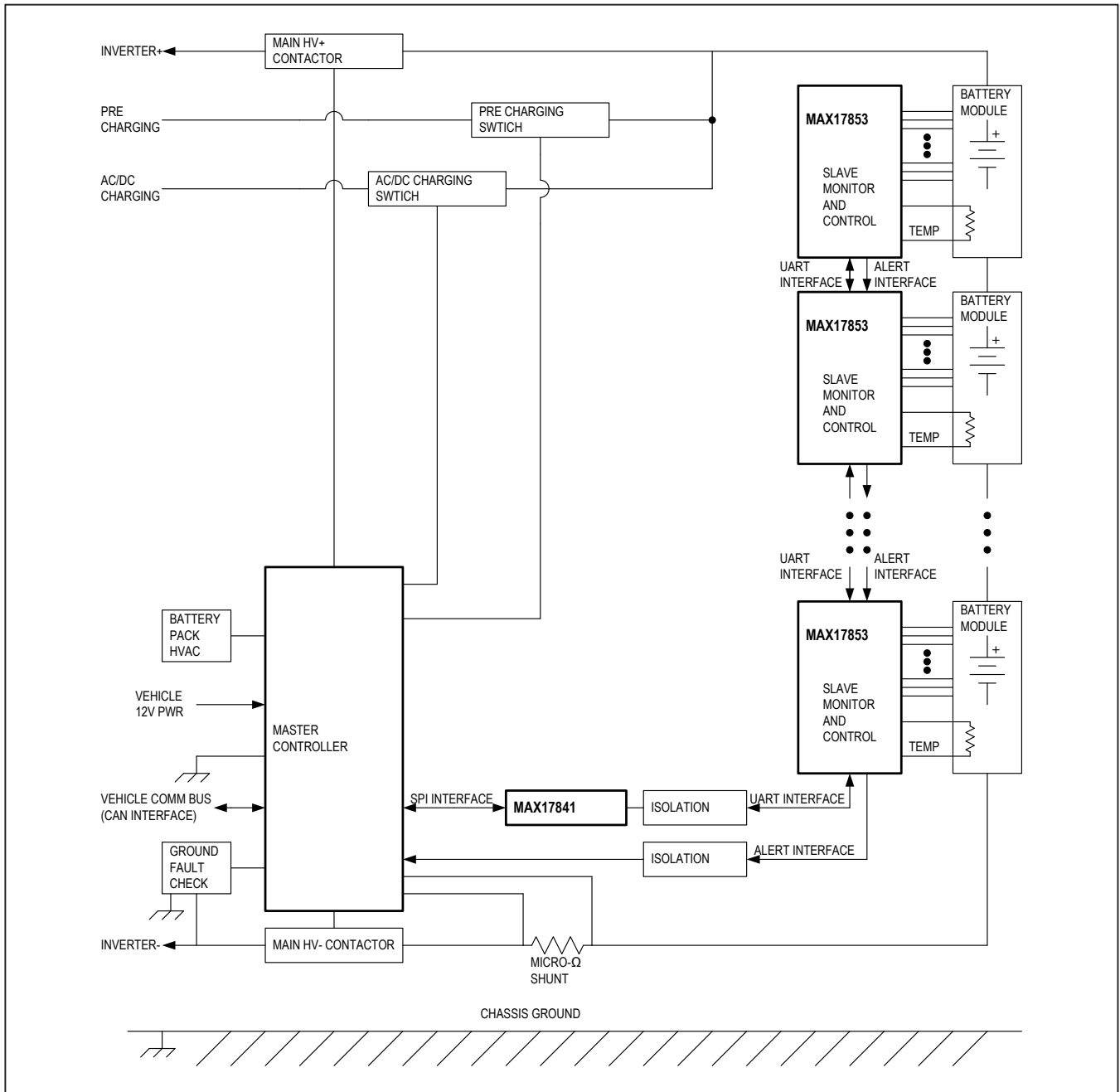

Figure 97. Daisy-Chain System

The GNDL1, GNDL2, and GNDL3 supply voltages are continuously monitored to be below V_{GNDL_OC} . If a ground goes below the threshold, the ALRTGNDL1, ALRTGNDL2, or ALRTGNDL3 alert is set.

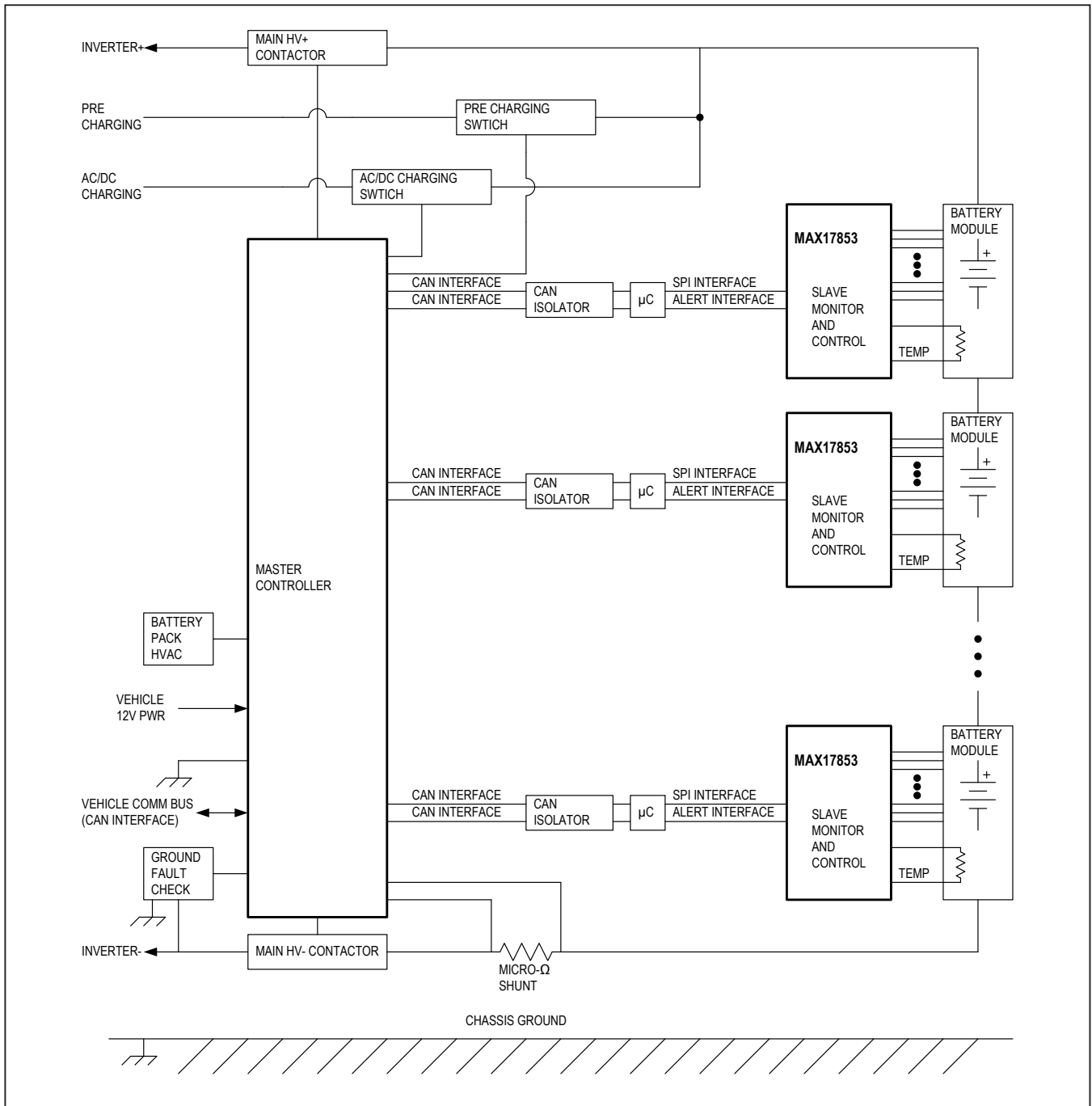

Figure 98. Distributed System

Applications Information

Vehicle Applications

Battery cells can use various chemistries such as NiMH, Li-ion (NMC, LFP, LTO), SuperCap or lead-acid. SuperCap cells are used in fast-charge applications such as energy storage for regenerative braking. An electric-vehicle system may require a high-voltage battery pack voltage from 400V to 800V, which translates from 100 to 200 Li-ion cells, or up to 500 NiMH cells.

A battery module is a number of cells connected in series that can be connected with other modules to build a high-voltage battery pack, as shown in [Figure 96](#). The modularity allows for economy, configurability, quick assembly, and serviceability. The minimum number of cells connected to any one device is limited by the device's minimum operating voltage. The 9V (min) for V_{DCIN} usually requires at least two Li-ion, six NiMH or six SuperCap cells per module.

Battery-Management Systems

Daisy-Chain System

A daisy-chain system employs a communication link between the host microcontroller and all the battery modules. The daisy-chain method reduces overall system cost as it requires only a single microcontroller, CAN PHY, and transformers between the lowest module and the host

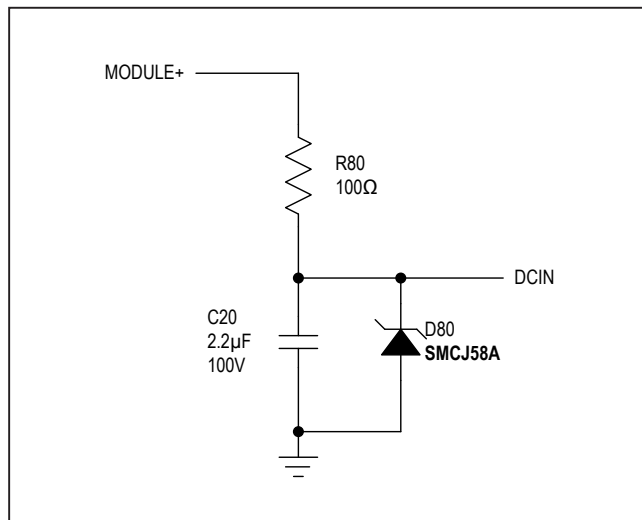

Figure 99. Power-Supply Connection

, whereas all components would require redundant implementation in a non-daisy-chain (distributed CAN system). See the [Distributed CAN Systems](#) section for further information regarding its implementation.

Distributed CAN Systems

A distributed CAN system ([Figure 98](#)) employs an individual CAN communication interface, battery-management microcontroller, and transformer isolation between each battery module and master controller/ECU. This system architecture, although realizable, yields increased system cost.

Standard Module Configuration

Power-Supply Connection

In a standard module configuration, both internal and external protection circuits permit the MAX17853 to derive its supply directly from the battery-module voltage using a filter network connecting the DCIN input to the top cell of the battery pack. These protection circuits protect against transients such as those that can occur when the battery voltage is first connected to the device, when the vehicle inverter is connected to the battery stack, or during charge/discharge transitions such as regenerative braking. The internal circuits include 72V tolerant battery inputs and a high-noise rejection ratio (PSRR) for the internal low-voltage regulator.

The external protection circuit shown in [Figure 99](#) filters and clamps the DCIN input. During negative-voltage transients, the filter capacitor maintains power to the device through the transient.

For maximum measurement accuracy, dedicated wires separate from the cell sense wires should be used for the power-supply connection (Kelvin sense). This eliminates voltage drops in the sense wires induced by supply current. If the application can tolerate the induced error, the supply wires can serve as the sense wires to reduce the wire count.

Connecting Cell Inputs

As mentioned in the previous section, the DCIN input should be connected to the battery module's top cell to prevent charge imbalance between cells. If the battery module contains less than 14 cells, the lowest order inputs (e.g., C1 and C0) should be utilized first and connected to the lowest common-mode signals. Any unused cell inputs should be shorted together, and unused switch inputs should also be shorted together. The TOPCELL register

must also be configured for stacks with less than 14 cells to mask out any false alerts corresponding to the unused channels.

The Flexible Pack (Flex Pack) Configuration provides system flexibility such that a single MAX17853 can meet the requirements of: varying battery module configuration(s) used across multiple mild EV, HEV, BEV distributed daisy-chain systems, as well as distributed daisy-chain

Flexible Pack Configuration
Power Supply, Cell Input Configuration

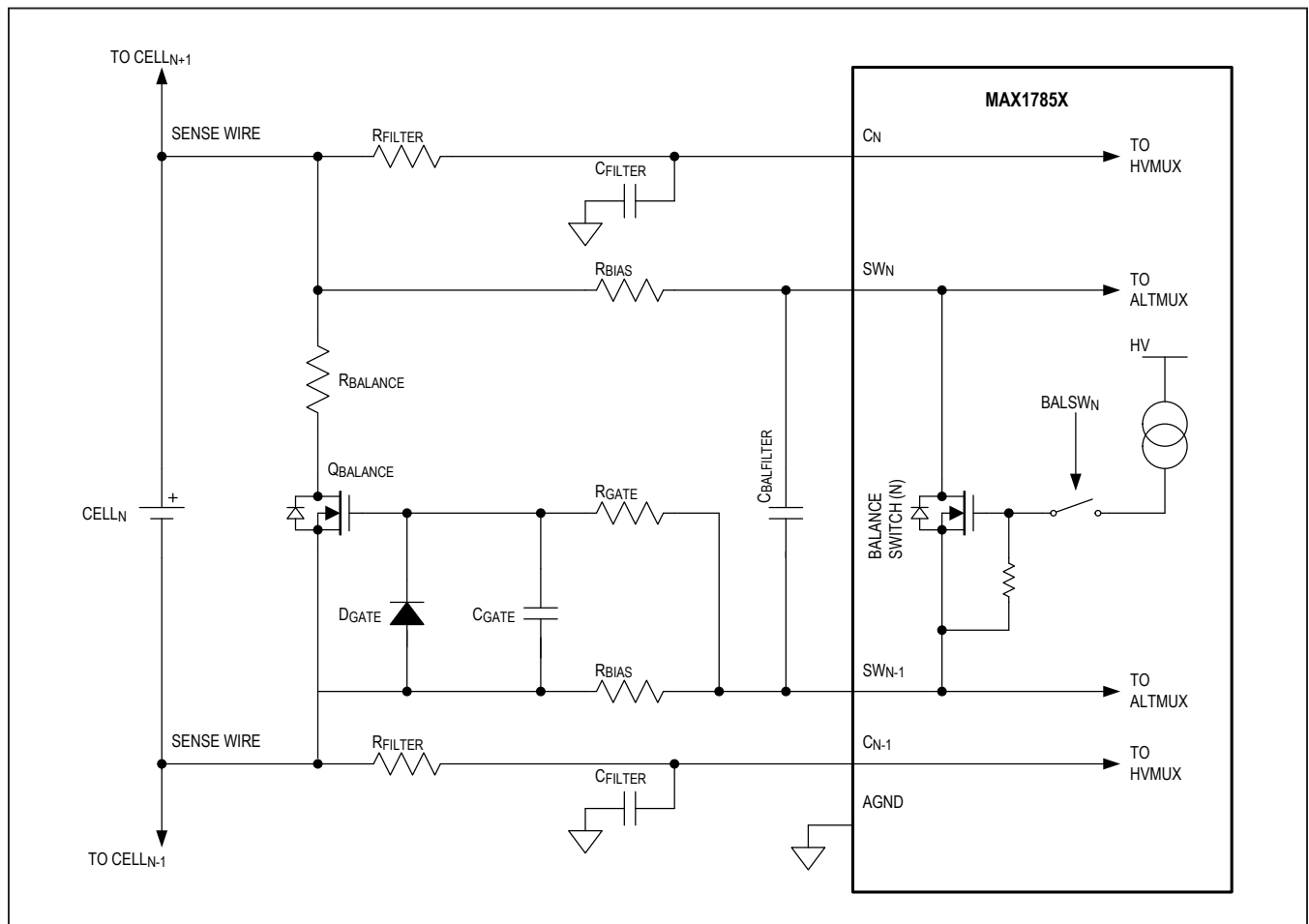

Figure 100. External-Balancing FET

Table 80. FET-Balancing Components

COMPONENT NAME	TYPICAL VALUE OR PART	FUNCTION
RBIAS	1kΩ	Voltage-divider for transistor bias
RGATE	100Ω	Hot-plug current-limiting resistor
DGATE	S1B	Reverse-voltage gate protection
CGATE	1nF	Transient VGS suppression
RBALANCE	per application	Balancing current-limiting resistor
QBALANCE	SQ2310ES	External switch

systems that employ unequal module sizes within a standard battery pack.

This flexibility is allowed through internal supply routing of the top battery cell as well as internal signal routing of the block voltage, where these connections were otherwise

required by discrete external traces. Due to this internal routing, the bill-of-materials (BOM) cost may be reduced through the elimination of the DCIN filter resistor as well as the block-voltage-measurement filter. Unused channels are left unconnected, allowing any battery wiring harness to connect to a standard battery module. See the

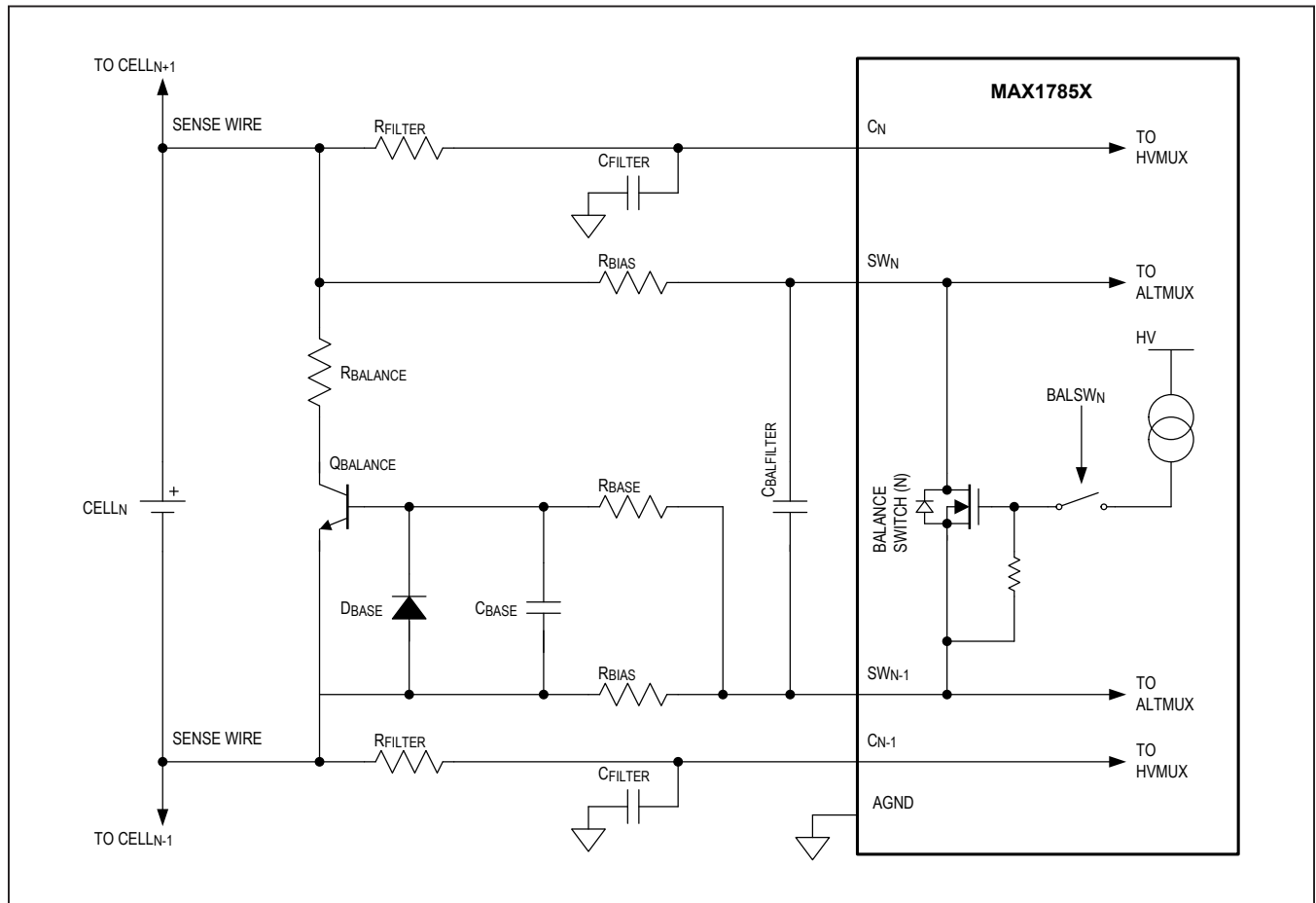

Figure 101. External Cell-Balancing BJT

Table 81. BJT Balancing Components

COMPONENT NAME	TYPICAL VALUE OR PART	FUNCTION
R _{BIAS}	22Ω	Voltage-divider for transistor bias
R _{BASE}	15Ω	Hot-plug current-limiting resistor
D _{BASE}	S1B	Reverse emitter-base voltage protection
C _{BASE}	1nF	Transient VBE suppression
R _{BALANCE}	per balancing current requirements	Balancing current-limiting resistor
Q _{BALANCE}	NST489AMT1	External switch

[Flexible Pack Configuration](#) section for further details on implementation.

For non-distributed daisy-chain systems (centralized systems), the Flex Pack eliminates the need to route external sense wires as the voltage drops from the cell cabling, which can be significantly reduced using the

FLXPCKSCAN bit in the PACKCFG register, resulting in total BOM cost reduction, as well as eliminating system cost and constraints for calibration.

External Cell Balancing

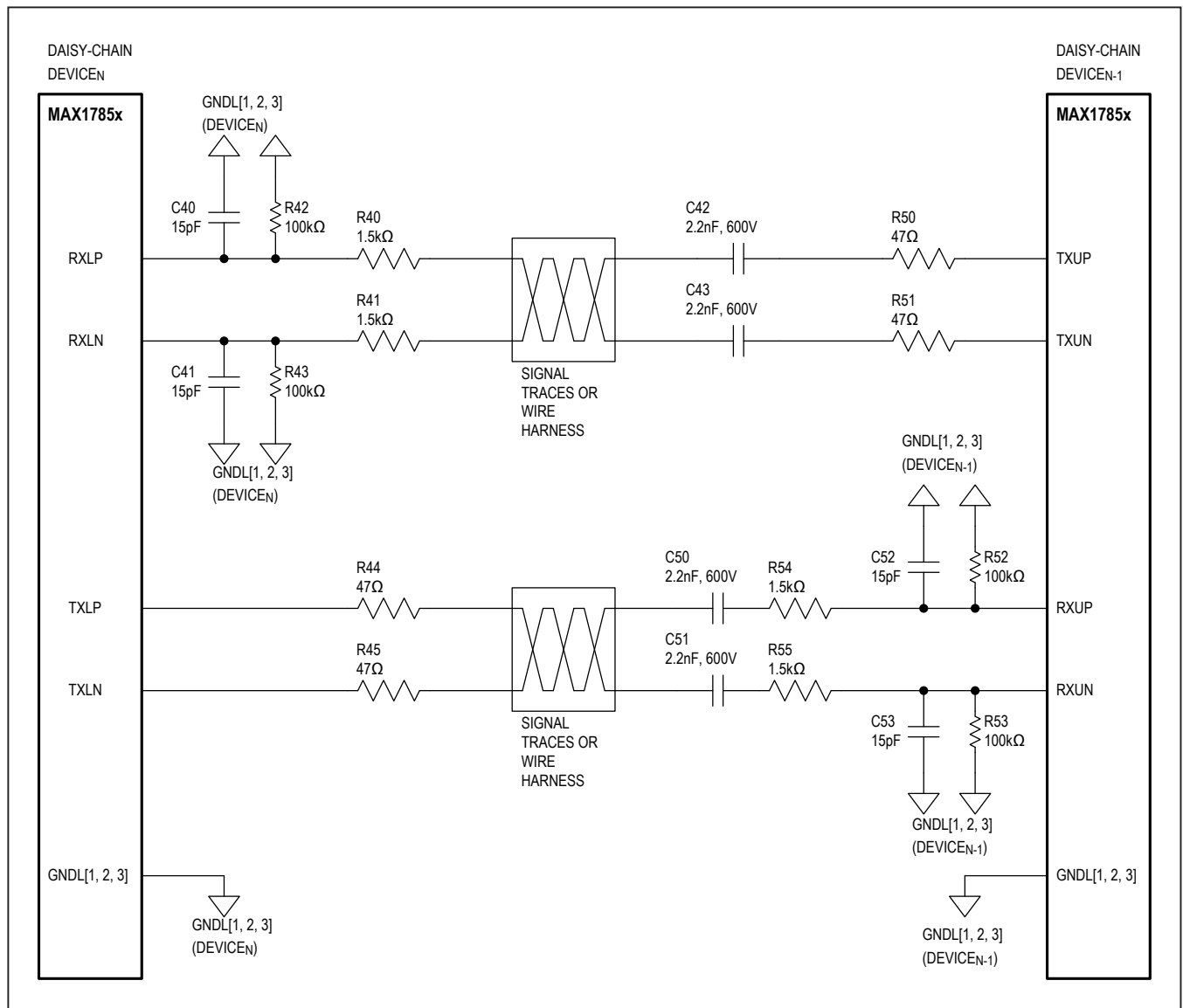

Figure 102. UART Connection

The cell-balancing current can be switched by external transistors if more power dissipation is required. The internal switches can be used to switch the external transistors, with the power limited by external current-limiting resistors.

External Cell-Balancing using FET Switches

An application circuit for cell balancing that employs FET switches is shown in Figure 100. Q_{BALANCE} is selected for low V_T that meets the minimum V_{CELLn} requirements of the application during balancing. D_{GATE} protects Q_{BALANCE} from reverse V_{GS} voltage during a hot-plug

event. R_{GATE} protects the device by limiting the hot-plug inrush current. C_{GATE} can be added to attenuate transient noise coupled from the drain to the gate to maintain the transistor bias. The cell-balancing current is limited by R_{BALANCE}. The various external cell-balancing summary components are shown in Table 80.

External Cell-Balancing Using BJT Switches

An application circuit for cell balancing that employs BJT switches is shown in Figure 101. Q_{BALANCE} is selected for power dissipation based on the IB drive

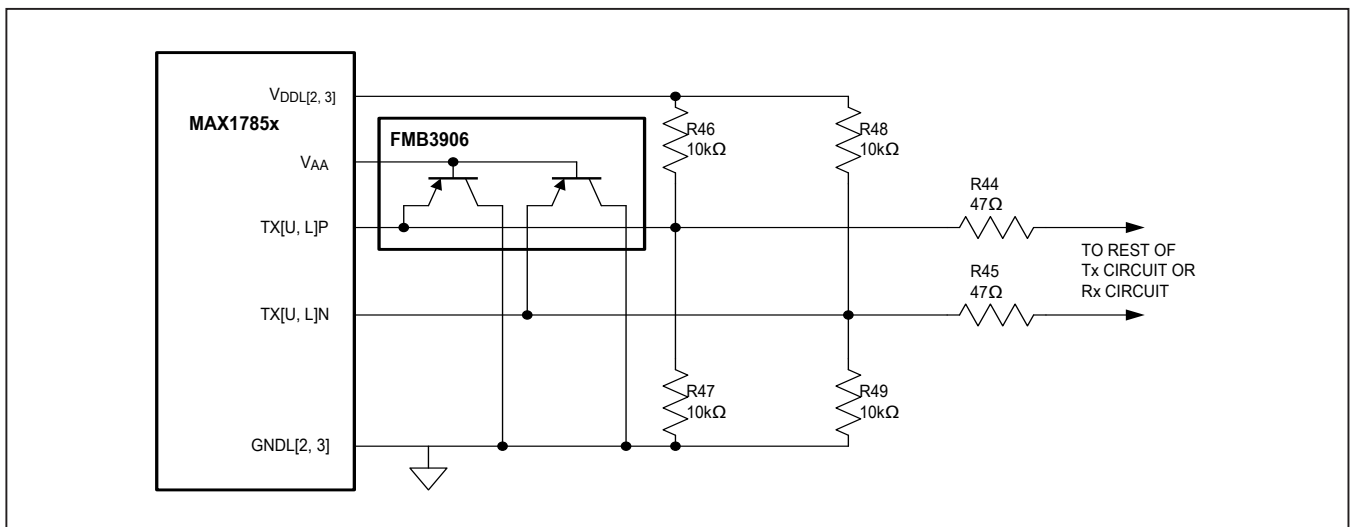

Figure 103. High-Z Idle Mode Application Circuit

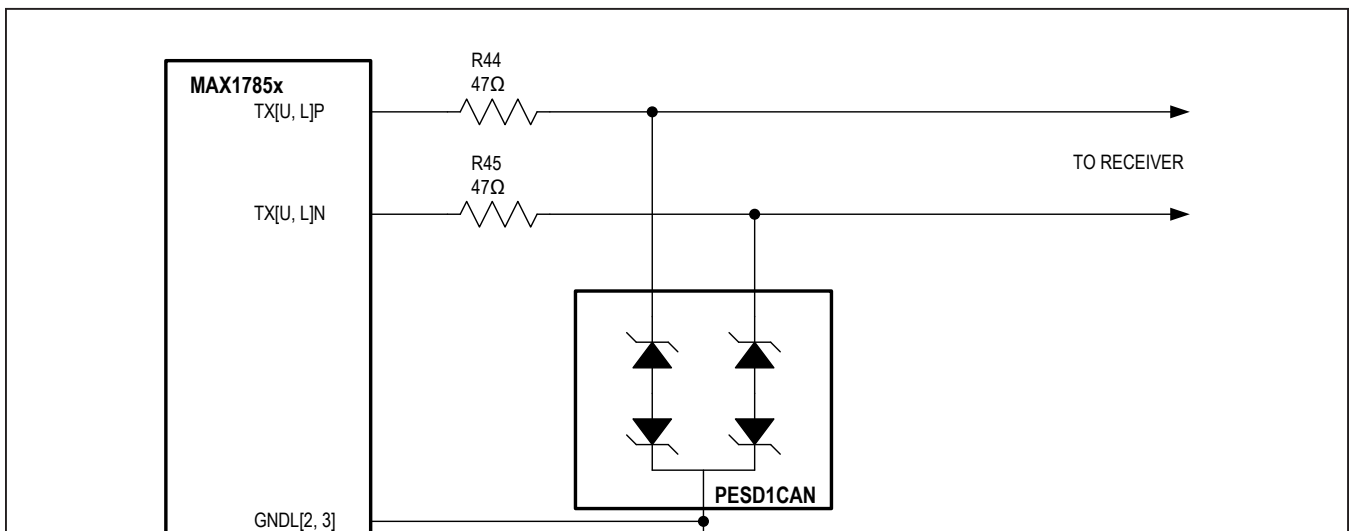

Figure 104. External ESD Protection for UART Tx Ports

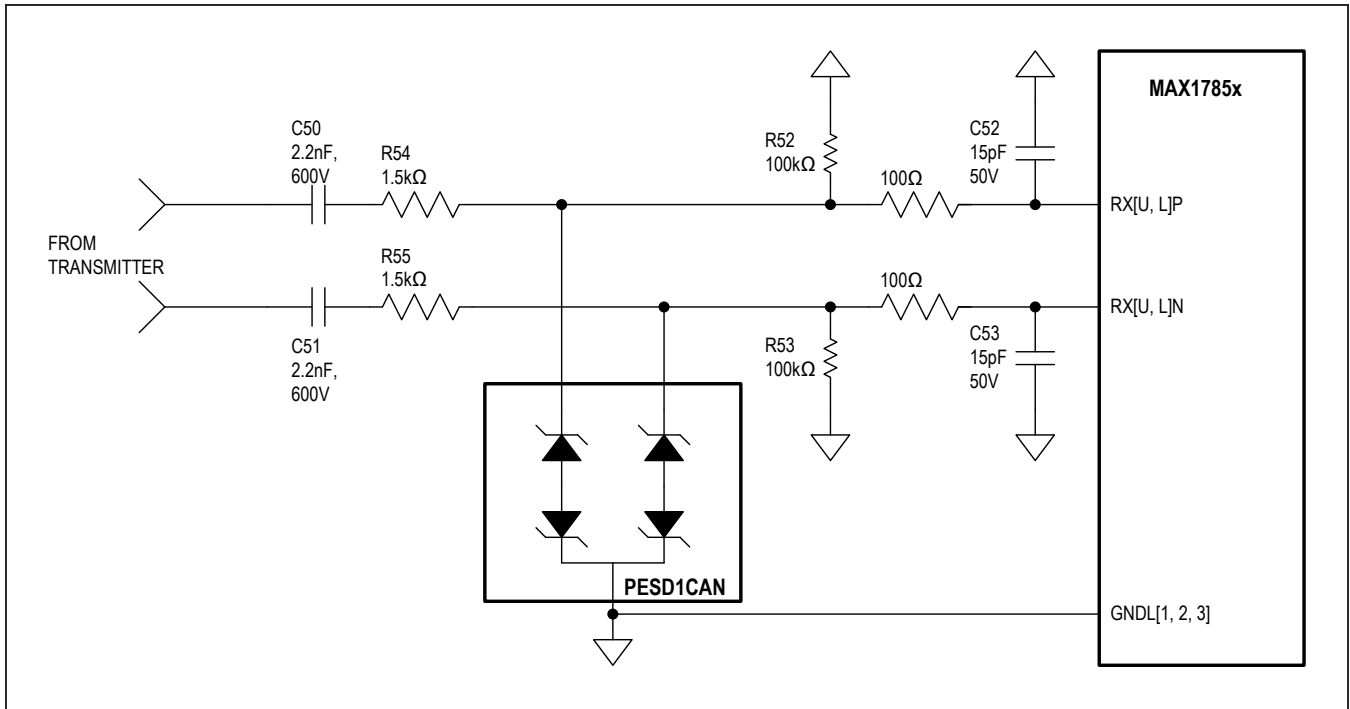

Figure 105. External ESD Protection for UART Rx Ports

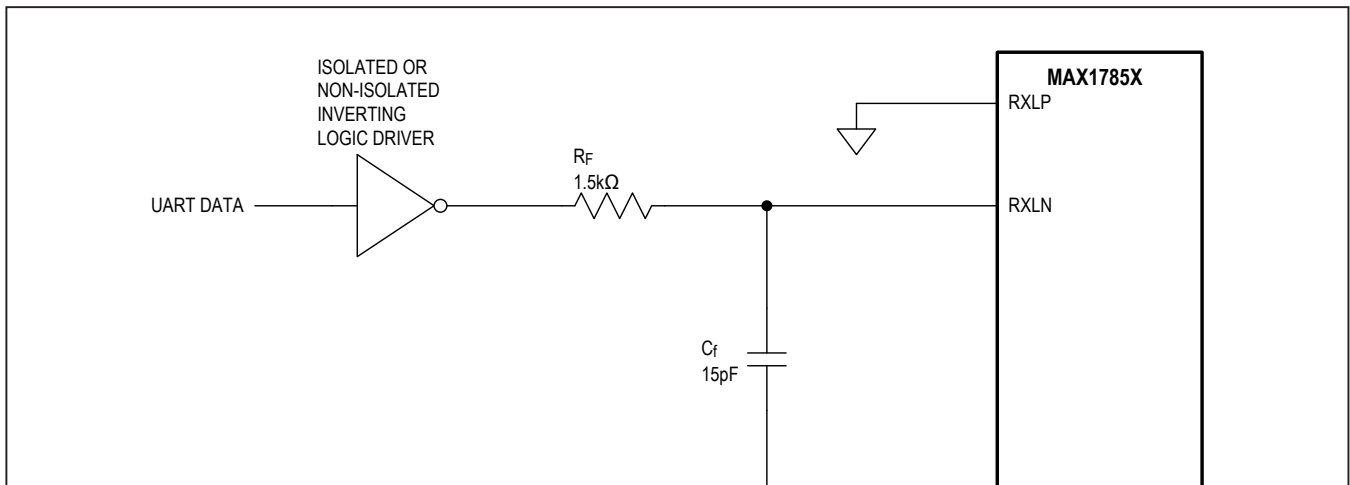

Figure 106. Application Circuit for Single-Ended UART Mode

current available and the cell-balancing current. D_{BASE} protects $Q_{BALANCE}$ from negative V_{GS} during hot-plug events. R_{BASE} protects the device by limiting the hot-plug inrush current. The cell-balancing current is limited by $R_{BALANCE}$. The various external cell-balancing summary components are shown in [Table 81](#).

External Cell-Balancing Short-Circuit Detection

A short-circuit fault in the external balancing path results in continuous current flow through $R_{BALANCE}$ and $Q_{BALANCE}$. To detect this fault, the voltage drop across

the sense-wire parasitic resistance must be measurable. A very small series resistor may be added for this purpose.

UART Interface

The UART pins employ both internal and external circuits to protect against noise. The recommended external filters are shown in [Figure 102](#). ESD protection is shown in [Figure 104](#) and [Figure 105](#).

High-Z Idle Mode

The high-Z idle mode lowers radiated emissions from wire harnesses by minimizing the charging and discharging of the AC-coupling capacitors when entering and exiting the idle mode. The application circuit shown in [Figure 103](#) uses a weak resistor-divider to bias the Tx lines to V_{DDL} during the high-Z idle period and pnp transistor clamps to limit the maximum voltage at the Tx pins during high noise injection. The resistor-divider and pnp clamps are not needed for applications utilizing only the low-Z mode. The low-Z and high-Z idle modes both exhibit a similar immunity to noise injection. Low-Z mode may be preferred for ports driving inductive loads to minimize ringing.

UART Supplemental ESD Protection

The UART ports may require supplemental protection to meet IEC 61000-4-2 requirements for contact discharge. The recommended circuits to meet $\pm 8\text{kV}$ protection levels are shown in [Figure 104](#) and [Figure 105](#). The protection components should be placed as near as possible to the signal's entry point on the PCB.

Single-Ended Rx Mode

To configure the lower port for single-ended Rx mode, the RXLP input is connected to digital ground and the RXLN input receives the inverted signal, just as it does for differential mode. If the host cannot transmit inverted data, then the signal must be inverted as shown in [Figure 106](#). Transmitter operation is not affected. If the up-stack device is single-ended, only the TXUN signal is required.

Note: In single-ended mode, SHDNL must be driven externally.

UART Isolation

The UART is expected to communicate reliably in noisy high-power battery environments where both high dV/dt

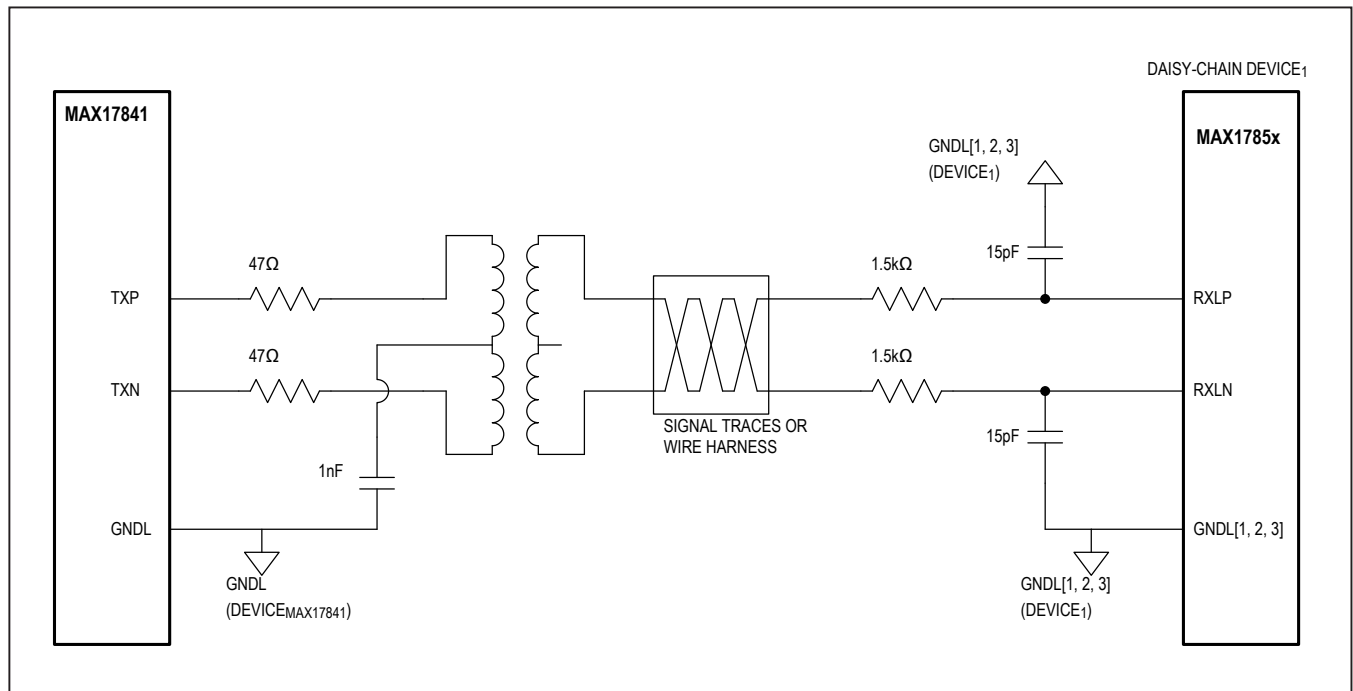

Figure 107. UART Transformer Isolation

supply noise and common-mode current injection induced by electromagnetic fields are prevalent. Common-mode currents can also be induced by parasitic coupling of the system to a reference node such as a battery or vehicle chassis. The daisy-chain physical layer is designed for maximum noise immunity.

The AC-coupled differential communication architecture has a $\pm 30V$ common-mode range and +6V differential swing. This range is in addition to the static common-mode voltage across the AC-coupling capacitors between modules. Transmitter drivers have low internal impedance and are source-terminated by the application circuit so that impedances are well matched in the high- and low-driver states. This architecture minimizes differential noise

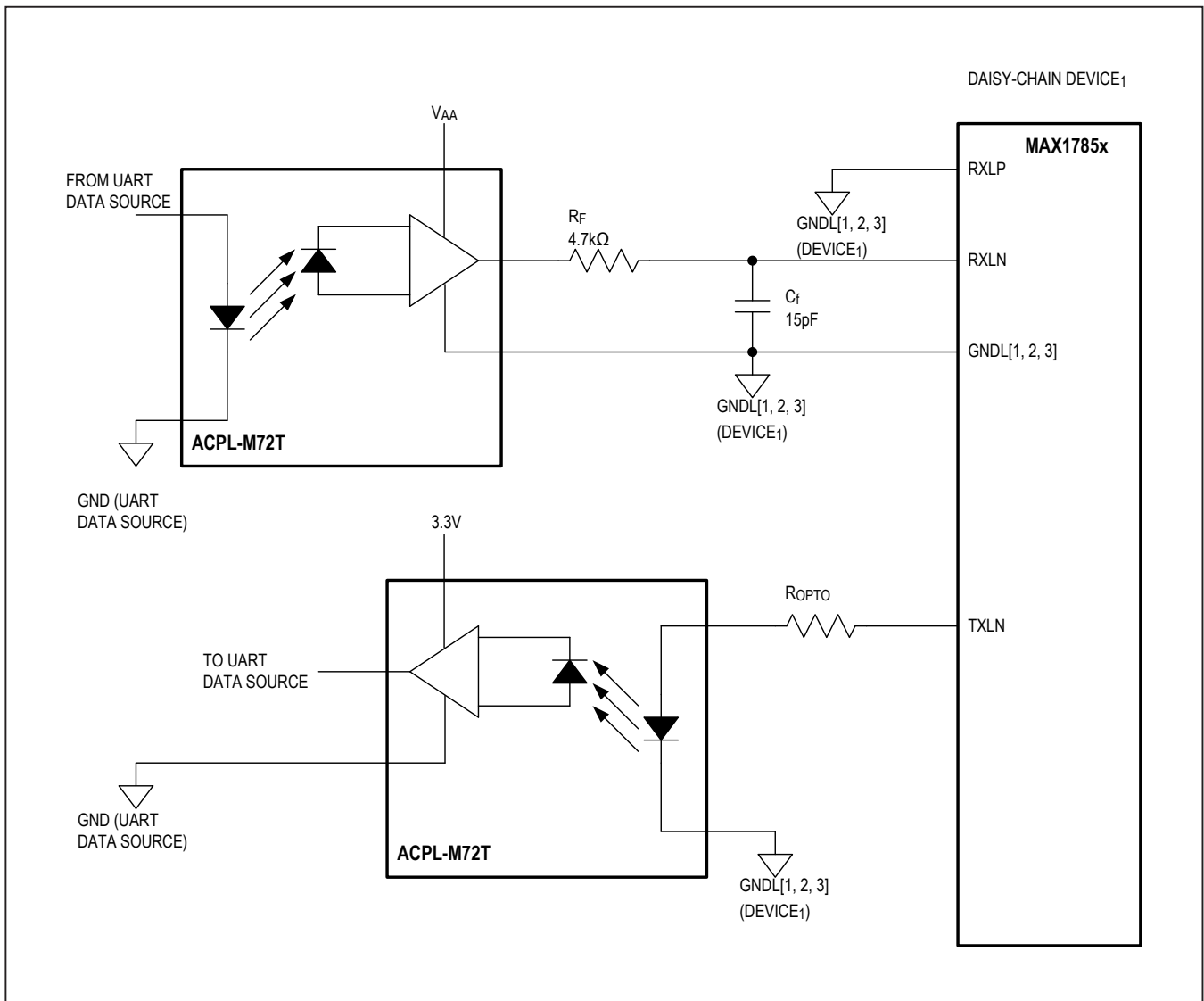

Figure 108. UART Optical Isolation

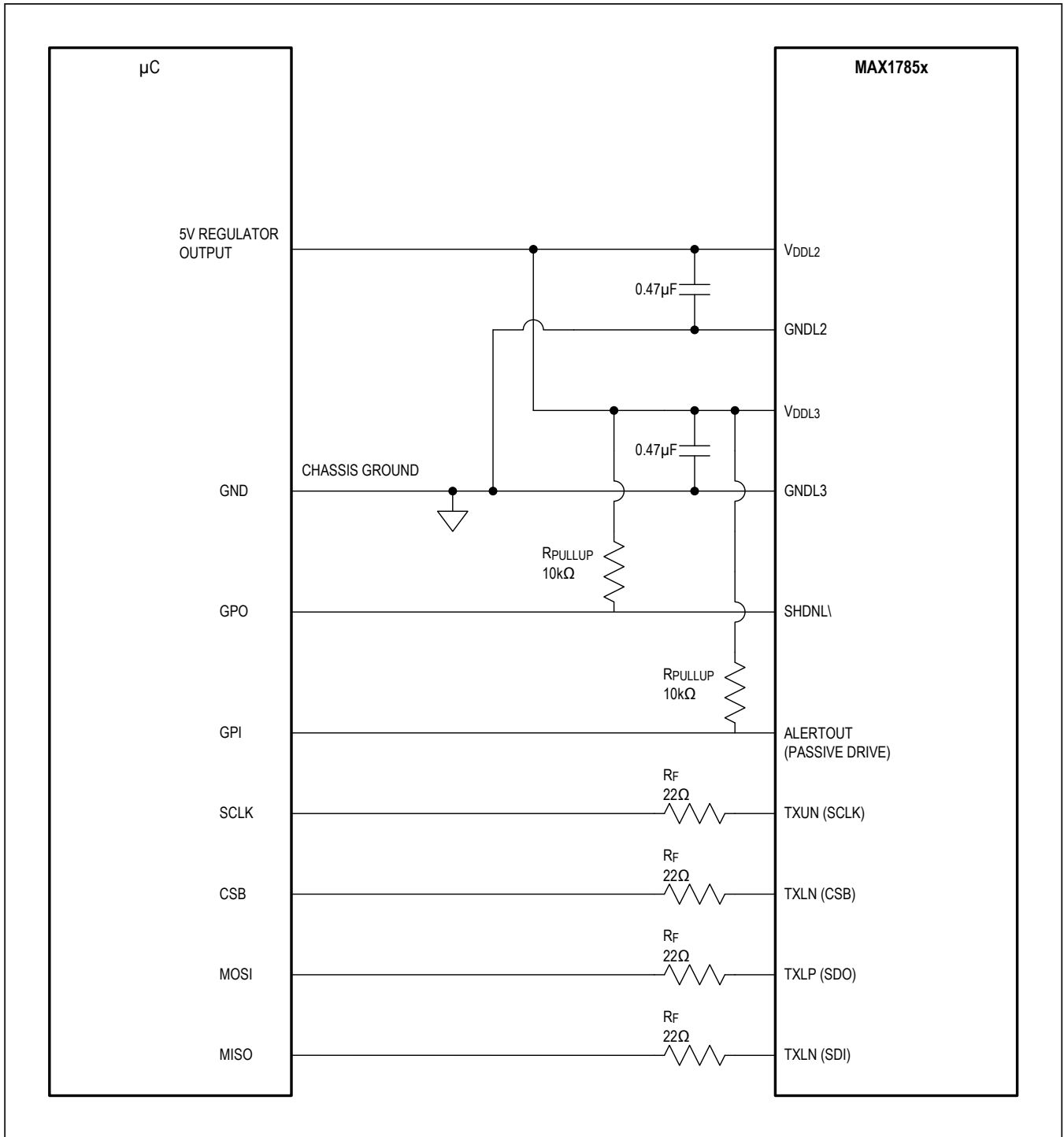

Figure 109. 5V SPI Supply from System

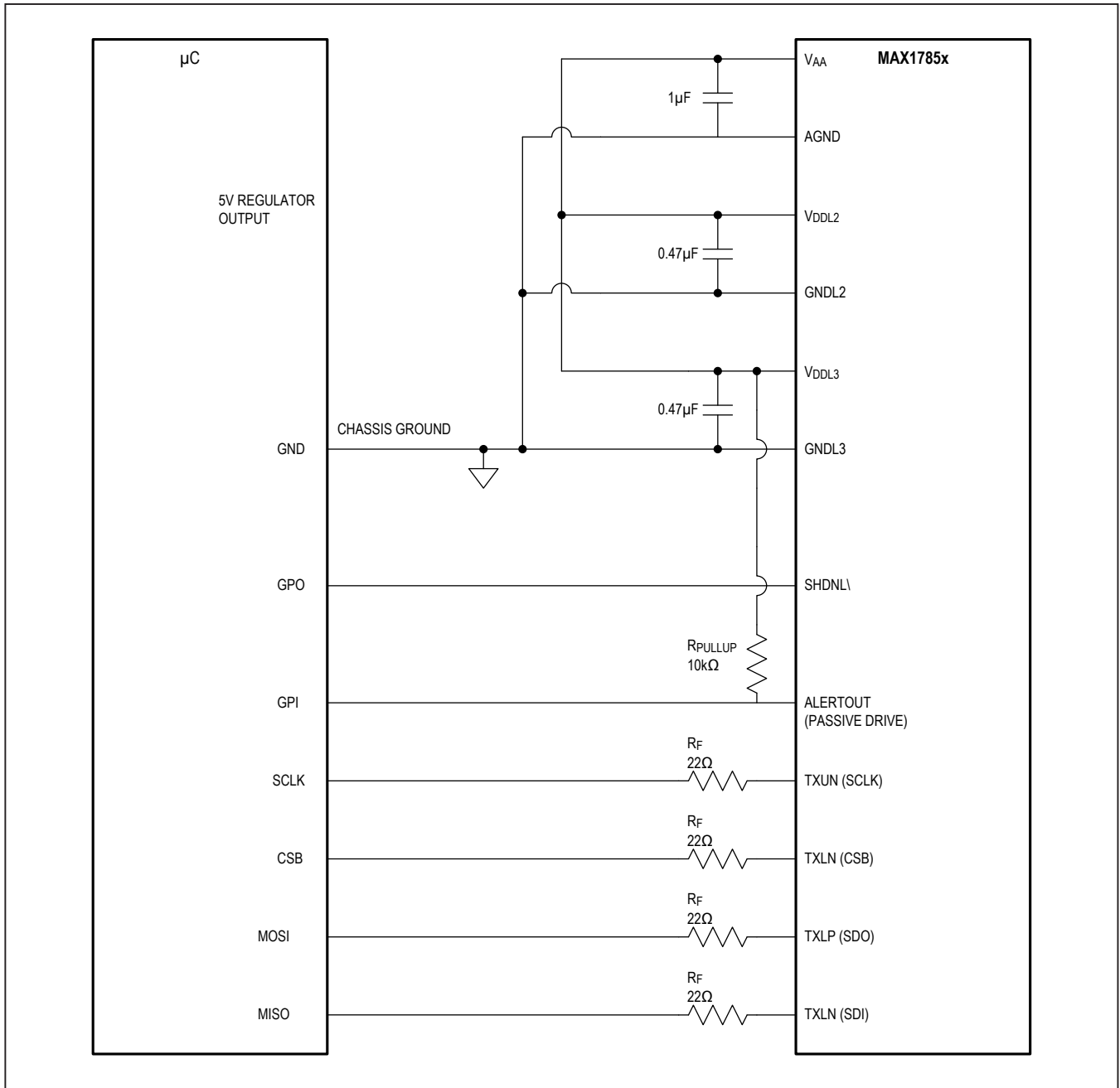

Figure 110. 3.3V SPI Supply from Device V_{AA} LDO

induced by common-mode current injection. The receiver inputs are filtered above the fundamental communication frequency to prevent high-frequency noise from entering the device. The system is designed for use with isolation transformers or optocouplers to provide an even higher degree of common-mode noise rejection in circuit locations where extremely large common-mode noise is present,

such as between vehicle chassis and the high-voltage battery-pack terminals.

Since a mid-pack service disconnect safety switch is present in many battery packs, the device is designed to communicate with the entire daisy-chain whether the service-disconnect switch is engaged or open. This is possible with daisy-chains that employ capacitor isolation.

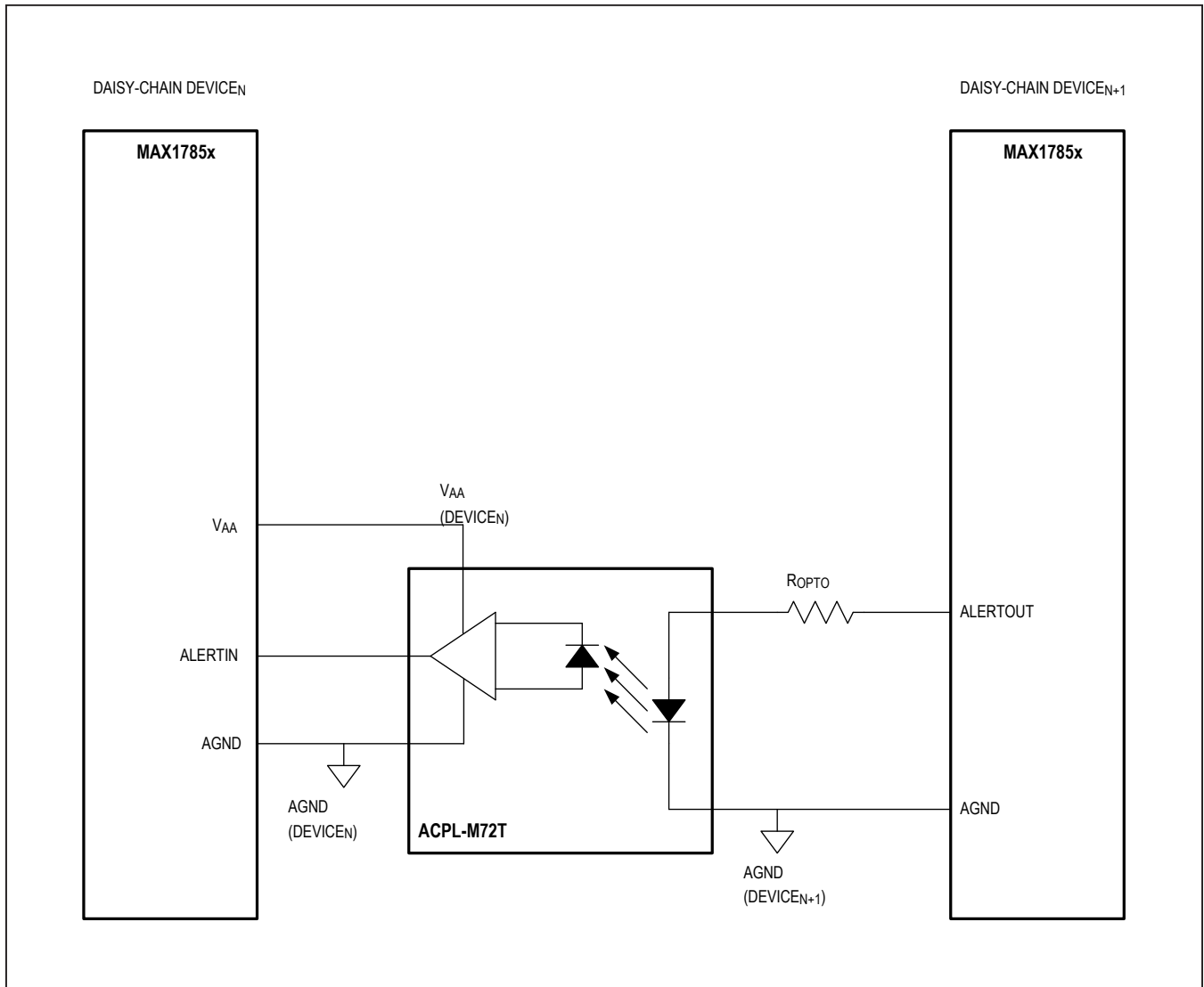

Figure 111. Single-End ALERT Interface in UART Mode

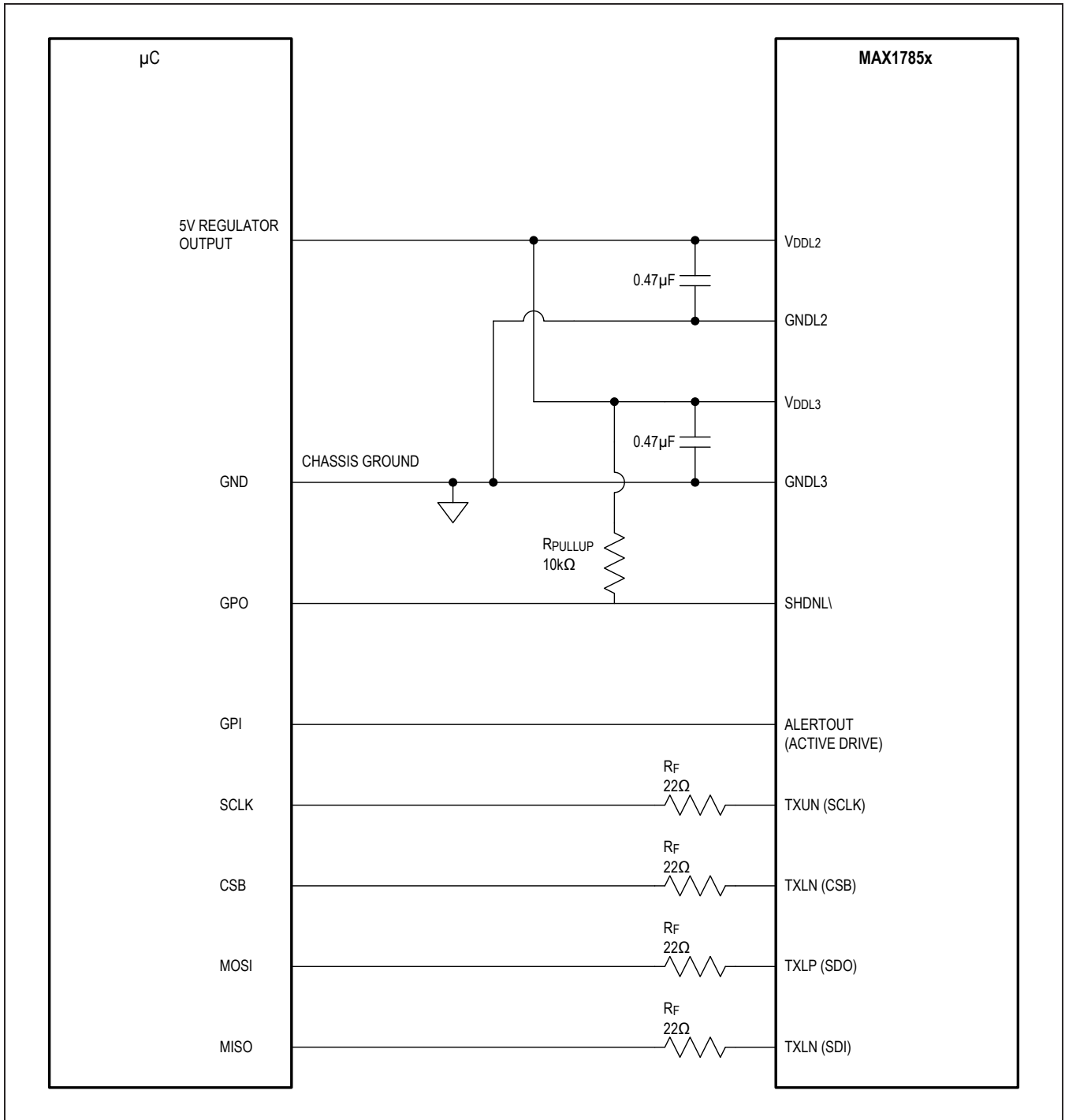

Figure 112. Single-End ALERT Interface in SPI mode - Active Drive

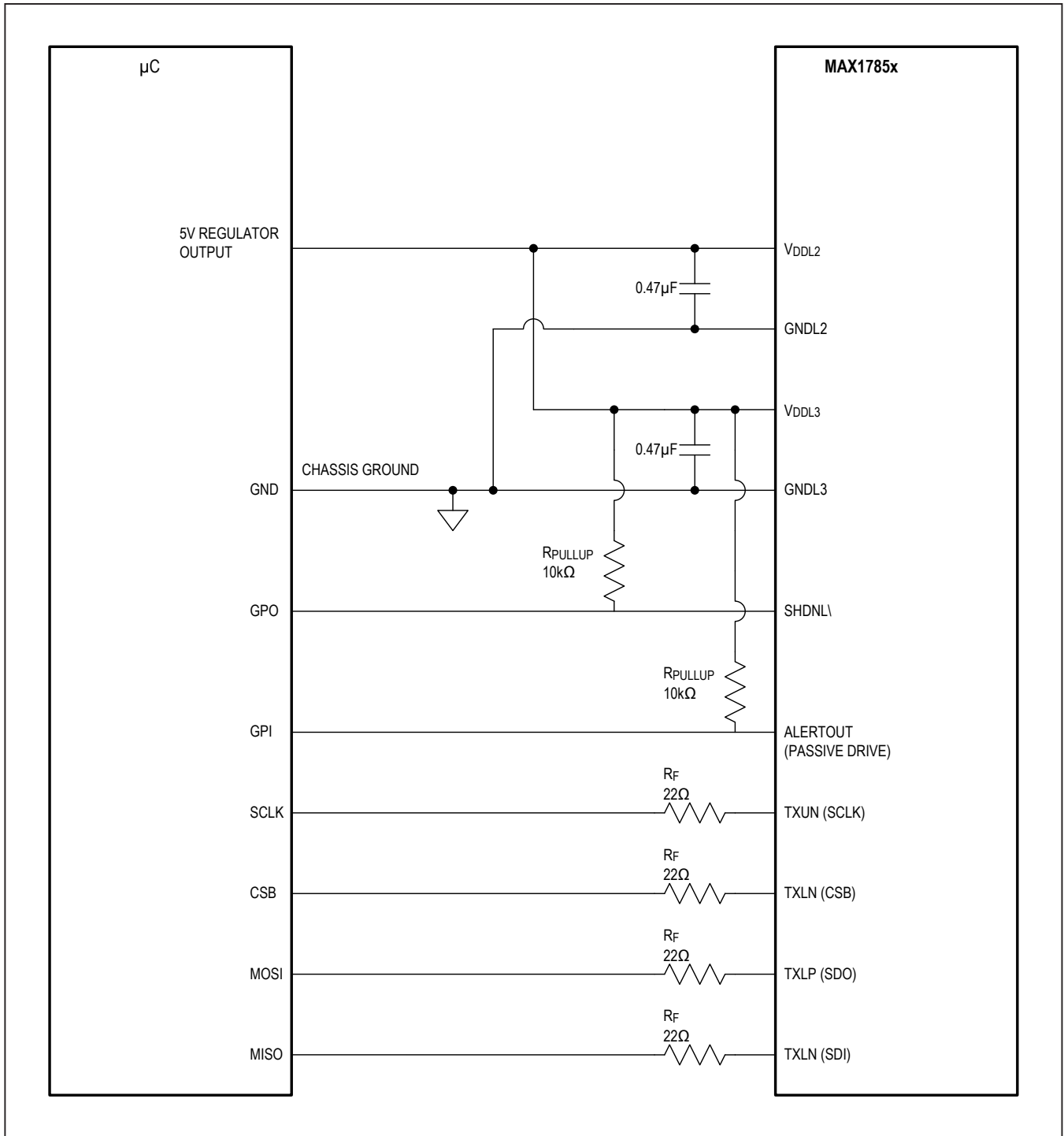

Figure 113. Single-End ALERT Interface in SPI mode - Passive Drive

UART Transformer Isolation

The UART ports may be transformer-coupled because of their DC-balanced differential design. Transformer coupling

between the MAX17841B interface and the MAX1785x provides excellent isolation and common-mode noise rejection (see [Figure 107](#)). The center-tap of a signal transformer may be used to enhance common-mode rejection

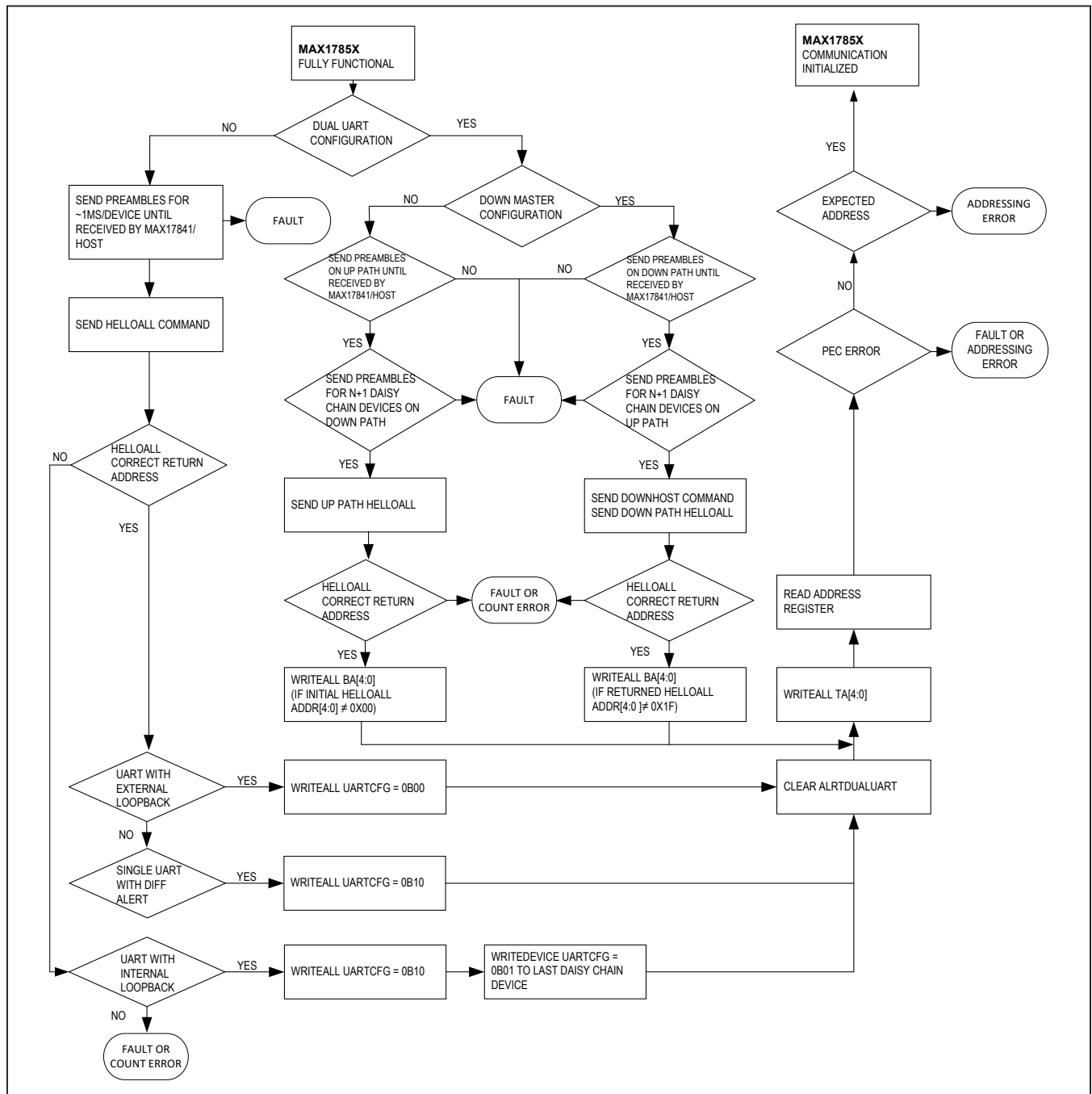

Figure 114. Device Initialization Sequence

by AC-coupling the node to local ground. Common-mode currents that are able to pass through the parasitic coupling of the primary and secondary are shunted to ground to make a very effective common-mode noise filter.

UART Optical Isolation

The daisy-chain may use optical isolation instead of transformer or capacitor isolation, as shown in [Figure 108](#).

SPI Interface

V_{DDL2} and V_{DDL3} are the supply pins for the SPI communication. SPI communication supports both 5V and 3.3V. The SPI supply configuration with 5V provided by the system is shown in [Figure 109](#).

The SPI supply configuration with 3.3V provided by the device's V_{AA} LDO output is shown in [Figure 110](#).

ALERT Interface

V_{DDL2} and V_{DDL3} are the supply pins for the Alert interface. When using the differential Alert interface in the UART daisy-chain configuration, the recommended external filters and ESD protection is same as the UART interface. When using single-end Alert interface (i.e., ALERTIN and ALERTOUT pins) in the UART daisy-chain, optical isolation is used, as shown in [Figure 111](#).

In SPI mode, one MAX1785x is applied in the system. The system can choose to supply V_{DDL2} and V_{DDL3} from the system's 5V or the device's V_{AA} LDO output. An active CMOS ALERTOUT output setting in the system is shown in [Figure 112](#).

A passive pulup ALERTOUT setting in the system is shown in [Figure 113](#).

Device Initialization Sequence

Immediately after reset, all device addresses are set to 0x00 and the UART baud rate and receive modes have not been auto-detected; therefore, the following initialization sequence is recommended after every reset or after any change to the hardware configuration.

Error Checking

Data integrity is provided by Manchester encoding, parity, character framing, and packet-error checking (PEC). The combination of these features verify stage-to-stage communication both in the write and read directions, with a Hamming distance (HD) value of 6 for commands with a length up to 247 bits (counted prior to Manchester encoding and character framing. This is equivalent to the longest possible command packet for a daisy-chain of up to 13 devices. The data-check byte is present in the READALL and READDEVICE commands to verify that

the entire command propagated without errors. Using the data-check and PEC bytes, complete transaction integrity for READALL and READDEVICE command packets can be verified.

PEC Errors

If the MAX17853 receives an invalid PEC byte, the corresponding ALRTPECUP, or ALRTPEC DN bit in the STATUS2 register, and the summary ALRTPEC bit in the STATUS1 register are set. All single-UART configurations set the ALRTPECUP bit, since the Up path is used for received transactions. In a dual-UART configuration, a PEC error in the Up path sets ALRTPECUP, and a PEC error in the Down path set the ALRTPEC DN. The MAX17853 does not execute/accept any written commands unless the received PEC byte matches the calculated CRC Remainder, confirming the validity of the received command and data stream. To confirm the command was accepted, the host should perform an appropriate read transaction to verify the contents of the written register(s).

PEC Calculations

When directly communicating with the MAX17853 through the UART interface, the host must compute and send the PEC byte, protecting the data sent to the device. Likewise, for returned read packets, the host should store the received data, perform the CRC calculation, and compare the results to the received PEC byte provided by the MAX17853 before accepting the data received as valid. To support PEC-byte computation and checking, the host must implement a CRC-8 (8-bit cyclic-redundancy check) encoding and decoding algorithm based on the following polynomial (0xA6):

$$P(x) = x^8 + x^6 + x^3 + x^2 + 1$$

This polynomial is capable of protecting a data stream of up to 247 bits with a Hamming distance of three, meaning any data stream 247 bits or less in length with any combination of 3 bits of error or less is guaranteed to be identified. If more than 3 bits of error are encountered, the PEC operation will very likely identify the problem, though this cannot be mathematically guaranteed.

A hardware implementation of the CRC calculation is shown in [Figure 115](#). The CRC Engine shown is implemented internally within the MAX17853; a similar implementation would be required in the host to support direct UART communication, for purposes of generating the PEC bytes sent to the MAX17853, or for checking PEC bytes received from the MAX17853. The incoming UART

data stream is fed into the CRC Engine LSB first. Once the data stream has been completely shifted into the engine, the CRC Remainder is known; this becomes the PEC byte for both incoming and outgoing data, $PEC[7:0] = BIT[7:0]$ as shown (be sure to note the ordering of the bits within the Remainder). Note that all UART transactions supply the command and data stream LSB first.

For incoming UART data streams, the MAX17853 first clears the CRC Engine and then inputs the incoming data stream into the CRC Engine, LSB first. After the final bit of data is processed (in this case, the MSB of the incoming data stream is applied to the Engine), the Engine is stopped and the CRC Remainder is known. The incoming PEC byte as calculated by the host using its copy of the CRC Engine then follows within the UART transaction (also LSB first), and is internally compared against the CRC Remainder as calculated by the MAX17853. If the PEC byte received matches the CRC Remainder calculated for the incoming data stream, the PEC operation is successful, and the transaction is accepted and executed by the MAX17853. If there is a mismatch, the MAX17853 rejects the transaction and issues the ALRTPEC status bit, notifying the host of the issue so the transaction can be resent.

For outgoing UART data streams, the MAX17853 first clears the CRC Engine and then provides the outgoing data stream to the CRC Engine, LSB first. After the final bit of data is processed (in this case, the MSB of the outgoing data stream is applied to the Engine), the Engine is stopped and the CRC Remainder is known, so this becomes the outgoing PEC byte. The outgoing PEC byte, as calculated by the MAX17853 using its copy of the CRC Engine, then follows within the UART transaction (also LSB first). As the host receives the data stream from the MAX17853, it should apply the data to its copy of the CRC Engine (LSB first, in the order it arrives in the UART transaction, until the MSB of the data stream is applied to the engine). At this point, there are two equivalent ways the host can complete the PEC operation to establish the validity of the received data:

- **Direct Comparison Method:** The host stops the CRC Engine once the data stream MSB is applied and compares the resulting CRC Remainder to the PEC byte supplied by the MAX17853 (again, LSB first). If the 2 bytes match, the data is accepted as valid; otherwise, it should be rejected. This is the method employed by the MAX17853 internally, as described above.

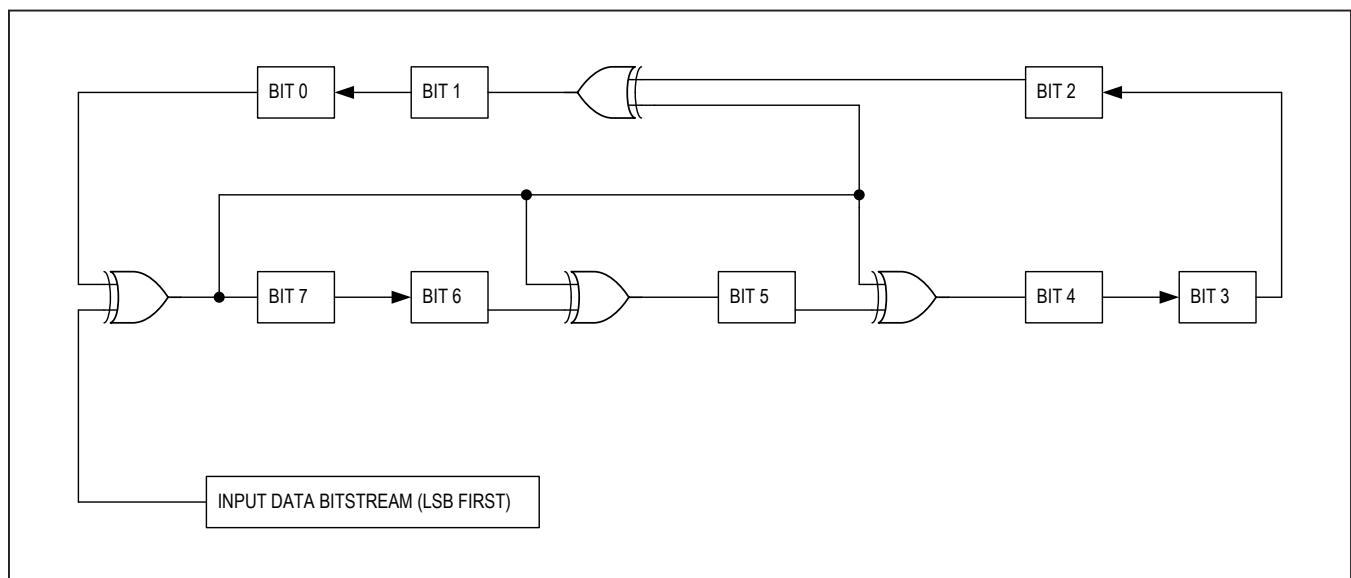

Figure 115. PEC CRC Calculation

- Zero-Remainder Method: The host continues CRC Engine computations after the data MSB is applied by appending the received PEC byte to the end of the data stream, LSB first (i.e., in the order received during the UART transaction). Once the MSB of the PEC byte arrives at the input of the CRC Engine, if the resulting CRC Remainder=00h, the data is accepted as valid; otherwise, it should be rejected.

PEC Calculation Pseudocode

The host uses the algorithm to process all bytes received in the command packet prior to the PEC byte itself. Neither the PEC nor the alive-counter bytes are part of the calculation. The bits are processed in the order they are received, LSB first. A byte-wise pseudo-code algorithm is shown below, but lookup table solutions are also possible to reduce host calculation time.

For commonly issued command packets, the host can pre-calculate (hard-code) the PEC byte. For commonly-used partial packets, the CRC value of a partial calculation may be used as the initial value for a subsequent run-time calculation.

```
Function PEC_Calculation(ByteList(), NumberOfBytes, CRCByte)
{
// CRCByte is initialized to 0 for each ByteList in this implementation, where
// ByteList contains all bytes of a single command. It is passed into the
// function in case a partial ByteList calculation is needed.
// Data is transmitted and calculated in LSb first format
// Polynomial = x^8+x^6+x^3+x^2+1 = 1010_0110_1 = 0xA6
POLY = 8'hB2 // 10110010b - Polynomial binary representation is from left to right for
LSB first (0xA6 -> 0xB2)
//Loop once for each byte in the ByteList
For ByteCounter = 0 to (NumberOfBytes - 1)
(
//Bitwise XOR the current CRC value with the ByteList byte
CRCByte = CRCByte XOR ByteList(ByteCounter)
//Process each of the 8 CRCByte remainder bits
For BitCounter = 1 To 8
(
// The LSb should be shifted toward the highest order polynomial
// coefficient. This is a right shift for data stored LSb to the right
// and POLY having high order coefficients stored to the right.
// Determine if LSb = 1 prior to right shift
If CRCByte[1] = 1 Then
// When LSb = 1, right shift and XOR CRCByte value with 8 LSbs
// of the polynomial coefficient constant. "/ 2" must be a true right
// shift in the target CPU to avoid rounding problems.
CRCByte = ((CRCByte / 2) XOR POLY)
Else
//When LSb = 0, right shift by 1 bit. "/ 2" must be a true right
// shift in the target CPU to avoid rounding problems.
CRCByte = (CRCByte / 2)
End If
//Truncate the CRC value to 8 bits if necessary
```

```

CRCByte = CRCByte AND 8'hFF
//Proceed to the next bit
Next BitCounter
)
//Operate on the next data byte in the
ByteList
Next ByteCounter
)
// All calculations done; CRCByte value is
the CRC byte for ByteList() and
// the initial CRCByte value
Return CRCByte
}

```

ROMCRC Calculation

For safety purposes, the factory-trimmed ROM (OTP) content can be read back by the user and checked for errors using an 8-bit CRC (cyclic-redundancy check). ROMCRC is an 8-bit CRC Remainder computed using the ID/OTP content and stored in OTP12[15:8] at the factory. Both the ID and OTP output data content (excluding OTP12[15:8], which ROMCRC[7:0]) and is protected by the ROMCRC operation. To support ROMCRC computation and checking, the host must implement a CRC-8 encoding and decoding algorithm based on the following polynomial (0xA6):

$$P(x) = x^8 + x^6 + x^3 + x^2 + 1$$

This polynomial is capable of protecting the 200 bit ID/OTP content with a Hamming Distance of three, meaning any combination of three bits of error or less is guaranteed to be identified. If more than three bits of error are encountered, the ROMCRC operation very likely identify the problem, though this cannot be mathematically guaranteed.

A hardware implementation of the CRC calculation is shown in [Figure 116](#). The CRC Engine shown would be implemented within the host. The same engine is used in the production trim software to compute and store the ROMCRC byte at the factory, using the computation method outlined below. Be sure to note the ordering of the bits within the Remainder, as shown in the figure (i.e. BIT[7:0] = ROMCRC [7:0]). Note that this is also the same CRC Engine used for PEC Byte CRC operations in UART mode.

To complete the ROMCRC operation, the host would first clear the CRC Engine and then apply the entire 200-bit content of the ID/OTP data received from the MAX17853 concatenated in the in the following order: ID1[0:15], ID2[0:15], OTP2[0:15], OTP3[0:15], OTP4[0:15], OTP5[0:15], OTP6[0:15], OTP7[0:15], OTP8[0:15],

OTP9[0:15], OTP10[0:15], OTP11[0:15], OTP12[0:7]. Note that this is essentially the entire ID/OTP content provided LSB-first - ID1[0] is the first bit applied to the CRC Engine and OTP12,7 is the last, and all 200 bits must be applied. At this point, there are two equivalent ways the host can complete the ROMCRC operation to establish the validity of the received ID/OTP data:

- **Direct Comparison Method:** The host stops the CRC Engine once the ID/OTP MSB is applied and compares the resulting CRC Remainder to the ROMCRC byte supplied by the MAX17853 as ROMCRC[7:0] (OTP12[15:8]). If the 2 bytes match, the data is accepted as valid; otherwise, it should be rejected and retried in case of a communication fault. If the failure persists, this may indicate a problem within the MAX17853 ROM.
- **Zero-Remainder Method:** The host continues CRC Engine computations after the data stream is applied by appending the received ROMCRC byte to the end of the data stream, LSB first (i.e., continuing the concatenation pattern shown above with OTP12[8:15], with OTP12,15 now being the last bit applied). Once the MSB of the ROMCRC byte arrives at the input of the CRC Engine, if the resulting CRC Remainder=00h, the data is accepted as valid; otherwise, it should be rejected and retried in case of a communication fault. If the failure persists, this may indicate a problem within the MAX17853 ROM.

Note: When using direct UART communication and a Block Readback of the ID/OTP content, the ROMCRC operation can be computed on the arriving data stream in the order received directly from the MAX17853 (since the UART interface transmits data LSB-first). If using this method, only the 200-bit OTP content should be applied to the CRC Engine (with or without the trailing ROMCRC, depending on the validation method selected above). If using the MAX17853 in UART mode in conjunction with a MAX17841, or in SPI mode, the host should first gather the entire contents of the ID/OTP, and then concatenate it and apply it to the CRC Engine as described above (with or without the trailing ROMCRC, depending on the validation method selected above).

In all cases, the user-interface transactions issued to fetch the ID/OTP data also will be protected by PEC operations (UART) or CRC operations (SPI). If either the PEC or CRC checks fail for the transaction itself, an interface issue has been identified. The user should retry the failed transactions to ensure the ID/OTP data and ROMCRC have been accurately received prior to accepting the results of the ROMCRC operation.

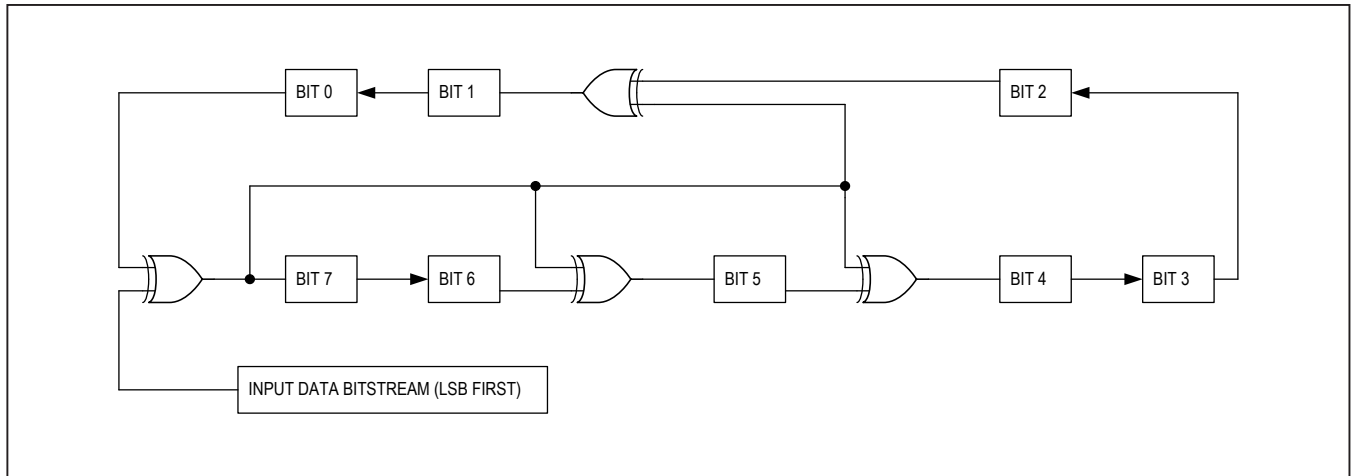

Figure 116. ROMCRC Calculation

PCB Layout Recommendations

Careful PCB layout is critical to achieving the best accuracy performance and robust performance against environmental conditions.

Layout Procedure

- 1) Place the charge-pump capacitor close to the CPP and CPN pins and on the same layer as the MAX17853. Care should be taken to avoid using vias to prevent unwanted coupling into adjacent signals and planes.
- 2) Place the decoupling capacitors on the V_{DCIN} , V_{AA} , V_{DDL1} close to the respective pins and on the same layer as the MAX17853. V_{DDL2} and V_{DDL3} should be placed close to the pins and is preferred on the same layer if possible. All capacitors should not share a ground return and each should via directly to the AGND internal layer.
- 3) AGND, GNDL1, GNDL2, GNDL3, AUXGND should via directly to a solid AGND plane placed under the MAX17853. Traces and vias should not be shared within before they enter the AGND plane.
- 4) The DCIN input resistor must be sized depending on both device current consumption (I_{DCIN}) and board current consumption (I_{VAA_LOAD}) to prevent false ALRTHVHDRM alerts. Adjustment of the DCIN resistor due to external loading should follow the following equation: $R_{DCIN_LOAD} = R_{DCIN_NOM} \times (1 - I_{DCIN}/I_{VAA_LOAD})$.
Note: In FlexPack operation, the DCIN filter resistor is omitted.
- 5) The SHDNL capacitor and associated trace routing should be kept away and shielded from potential noise sources and digital signals such as those present with the communication or alert interfaces as these may affect the voltage seen by the SHDNL pin.
- 6) C_n traces are recommended to be routed on the same layer as the MAX17853 to avoid the potential sources for noise injection into the primary measurement path. These traces carry a negligible current and can be kept at minimum trace widths.
- 7) SW_n traces should be optimized for width in the permissible layout (20 mil recommended) to eliminate excessive voltage drop due to the balancing operation.
- 8) UART Rx and Tx ports should be routed for a 100 Ω differential impedance. If the MAX17853 is used in a distributed BMS system, ESD protection is recommended placed as close to the UART communication connector with the ground return via'ed directly to the AGND plane to clamp transient events before they can couple to other nodes, which may affect device performance. For centralized BMS systems, ESD components on the UART can be omitted.
- 9) SPI operation will be driven by a system microcontroller, which is located on the same ground plane as the MAX17853. Depending on trace length, optional source termination may be required to ensure that overshoot or undershoot does not violate the Absolute Maximum Operating Conditions. This source termination should be placed close to the Tx pins of the device.

Ordering Information

PART	TEMP RANGE	PIN-PACKAGE
MAX17853ACB/V+	-40°C to +125°C	64 LQFP

/V Denotes an automotive-qualified package.

+Denotes a lead(Pb)-free/RoHS-compliant package.

Revision History

REVISION NUMBER	REVISION DATE	DESCRIPTION	PAGES CHANGED
0	7/18	Initial release	—
1	1/19	Updated <i>Benefits and Features</i> , <i>Package Information</i> , <i>Electrical Characteristics</i> table, Note 15, removed Note 18, updated Notes SPI-4 and SPI5, <i>Pin Description</i> , <i>ADC Input Range</i> , <i>Ramp-Mode Acquisition Time</i> , <i>Comparator Acquisition</i> , <i>Cell Statistics</i> , <i>Temperature Alerts</i> , <i>Cell-Balancing Mode Configurations</i> , <i>Address Cyclic-Redundancy Check—CRCA[2:0] (DI[22:20])</i> , <i>Input Data Cyclic-Redundancy Check—CRCD[2:0] (DI[2:0])</i> , <i>Address Cyclic Redundancy Check—CRCA[2:0] (DI[22:20])</i> , <i>Input-Data Cyclic-Redundancy Check—CRCD[2:0] (DI[2:0])</i> , <i>Output-Data Cyclic-Redundancy Check—CRCO[2:0] (DO[2:0])</i> , <i>Status Cyclic Redundancy Check—CRCS[2:0] (DO[26:24])</i> , Table 66, <i>VERSION (0x00)</i> , <i>DEVCF1 (0x14)</i> , and <i>Ordering Information</i>	1, 23, 25, 26, 29, 32, 36, 65, 73, 74, 94, 95, 136–139, 141, 148, 185, 208, 314
2	3/19	Updated Figure 1 and Figure 3	40, 42
3	8/19	Updated <i>Ordering Information</i> to remove MAX17853GCB/V+	314
4	11/19	Updated <i>Electrical Characteristics</i> table	29

For pricing, delivery, and ordering information, please visit Maxim Integrated's online storefront at <https://www.maximintegrated.com/en/storefront/storefront.html>.

Maxim Integrated cannot assume responsibility for use of any circuitry other than circuitry entirely embodied in a Maxim Integrated product. No circuit patent licenses are implied. Maxim Integrated reserves the right to change the circuitry and specifications without notice at any time. The parametric values (min and max limits) shown in the *Electrical Characteristics* table are guaranteed. Other parametric values quoted in this data sheet are provided for guidance.