

Card Edge Connector 0.156" (3.96mm) Pitch

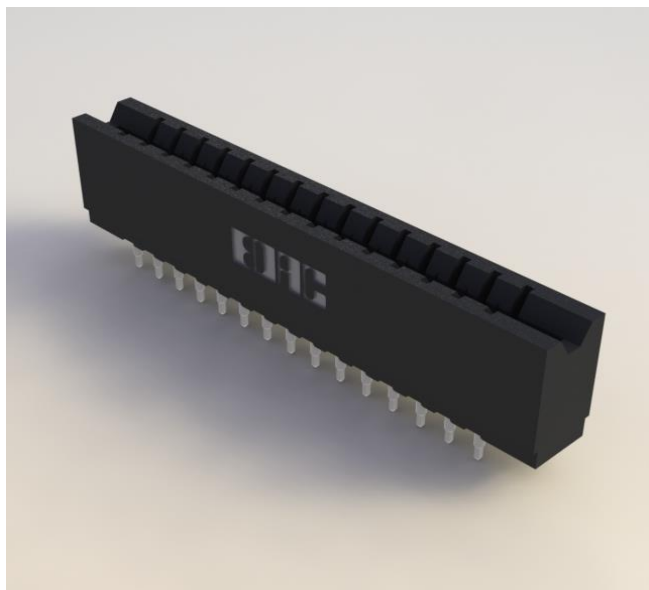

FEATURES:

- .156" (3.96mm) Contact spacing x .200" (5.08mm) row spacing
- Accepts .062" (1.57mm) nominal thickness P.C. board
- High profile insulator body, .645" (16.38mm) with notched ends Option
- Contact termination options include P.C. tail, and .025" (0.64mm) square wire wrap
- Press-Fit compliant section for gas tight reliable connection in plated through holes eliminates soldering operations
- Single or dual row configurations
- Accepts between contact and In-Contact polarizing keys (Special features if requested)
- Tools available for insulator and contact removal. Simple "Flat Rock" tooling is used for connector installation.
- RoHS Compliant & UL Certified

SPECIFICATIONS:

Insulator Material	UL 94V-0 Thermoplastic Polyester, Black
Contact Material	Copper Alloy
Contact Plating	30u" Gold Plating on mating area and Tin Plating on tails with Nickel underplating all over
Current Rating	3 Ampere
Contact Resistance	10 milliohms Maximum
Dielectric Withstand Voltage	1200VAC rms at sea level between adjacent contacts
Insulation Resistance	5000 Megohms Minimum
Operating Temperature	-40°C to +105°C
Insertion Force	16oz (4.45N) Maximum per contact pair when tested with .070" (1.78mm) thick gauge
Withdrawal Force	1oz (0.28N) Minimum per contact pair when tested with .054" (1.37mm) thick gauge
Contact insertion into Hole	20 lbs (89 N) Maximum
Contact Retention in Hole	10 lbs (44 N) Minimum
Re-Insertability in same Hole	3 Times Minimum

EXAMPLE PART NUMBER: **737-044-520-206**

Series	_____
Total Number of Contacts	_____
Contact Code	_____
Contact Rows	_____

Contact Code	Description & Contact Point	Tail length "G"
520	P.C. Tail Regular Point	.190 (4.83)
522	P.C. Tail Regular Point	.375 (9.53)
525	P.C. Tail High Point	.190 (4.83)
540	Wire Wrap Regular Point	.560 (14.22)
541	Wire Wrap Regular Point	.750 (19.05)
545	Wire Wrap High Point	.560 (14.22)
560	Make Before Break (MBB) Contacts	.190 (4.83)

Series: **737**

Total Number of Contacts:	Contact Rows
005, 006, 043	Single Row
010, 012, 086	Dual Row

Contact Rows:	Description
101,106	Single Row
201,206	Dual Row

Ordering Code Notes:

- 1) All connector sizes up to 43 contacts single row / 86 contacts dual row are available upon request.
- 2) Make-Before-Break switching contacts, assembled in specific contact positions, are available upon request.

IN-CONTACT
POLARIZING KEY
P/N 745-240-328



BETWEEN CONTACT
POLARIZING KEY
P/N 306-240-318

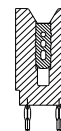

Card Edge Connector 0.156" (3.96mm) Pitch

SECTIONS "Y" — "Y"
CONTACT ROWS & INSULATOR OPTIONS

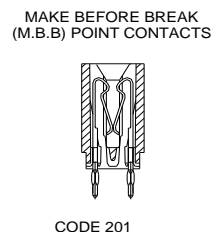
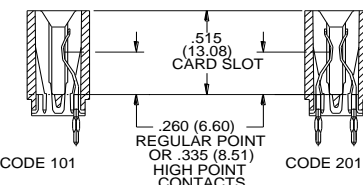
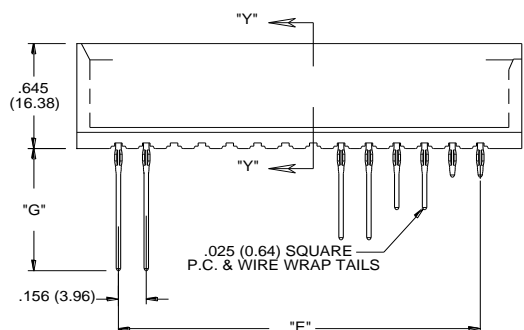
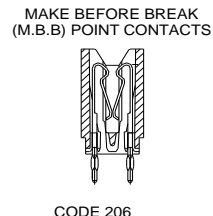
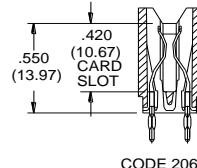
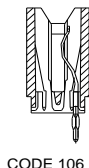
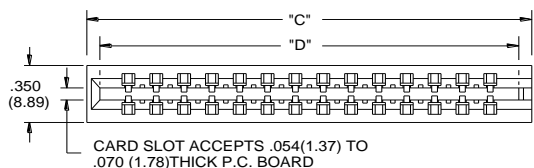

Single Row Versions May Require Backup Springs Depending upon the Application.

FOR NOTCHED ENDS OPTION (106&206) ONLY

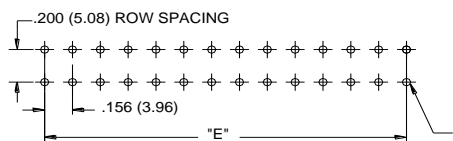
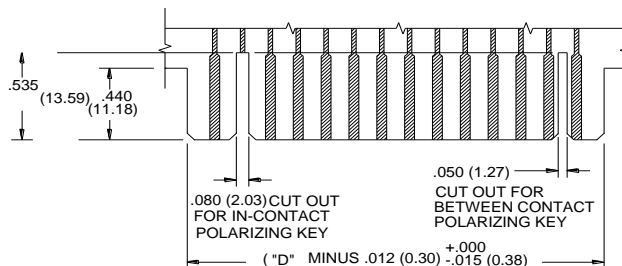

.040 (1.02) DIA ± .003 (0.08)
SEE NOTE BELOW
Φ .008 (0.20) DIA

TO OBTAIN OPTIMUM COMPLIANT SECTION PERFORMANCE,
DRILL HOLES .0453 ± .001 (1.15 ± 0.03) DIAMETER
COPPER PLATE, .001 (25.4 MICRONS) MINIMUM THICKNESS,
FOLLOWED BY TIN PLATE TO PROVIDE FINISHED
HOLES .040 ± .003 (1.02 ± 0.08) DIAMETER

NUMBER OF CONTACTS		"C"		"D"		"E"	
Single	Double	Inch	mm	Inch	mm	Inch	mm
5	10	1.090	27.69	0.944	23.98	0.624	15.85
6	12	1.246	31.65	1.100	27.94	0.780	19.81
10	20	1.870	47.50	1.724	43.79	1.404	35.66
15	30	2.650	67.31	2.504	63.60	2.184	55.47
18	36	3.118	79.20	2.972	75.49	2.652	67.36
20	40	3.430	87.12	3.284	83.41	2.964	75.29
22	44	3.742	95.05	3.596	91.34	3.276	83.21
25	50	4.210	106.93	4.064	103.23	3.744	95.10
28	56	4.678	118.82	4.532	115.11	4.212	106.98
30	60	4.990	126.75	4.844	123.04	4.524	114.91
31	62	5.146	130.71	5.000	127.00	4.680	118.87
33	66	5.458	138.63	5.312	134.92	4.992	126.80
36	72	5.926	150.52	5.780	146.81	5.460	138.68
43	86	7.018	178.26	6.872	174.55	6.552	166.42