

## USB Type-C™ Power Delivery SINK expansion board based on TCPP01-M12 for STM32 Nucleo

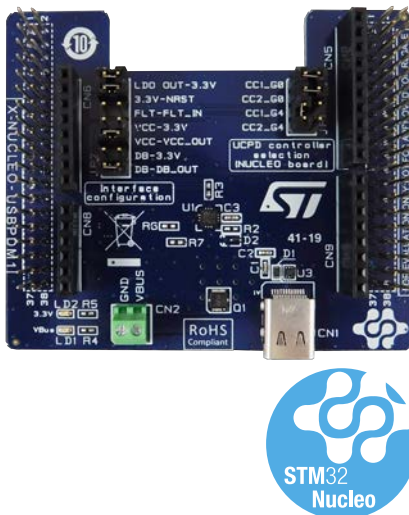

### Features

- USB Type-C reversible connector
- 6 V overvoltage protection (OVP) on CC lines against short-to- $V_{BUS}$  when the connector is unplugged
- Up to 22 V adjustable overvoltage protection (OVP) on  $V_{BUS}$  line against charger failure
- Surge protection and system-level ESD protection on  $V_{BUS}$
- Common-mode filter and ESD protection on USB 2.0 High Speed data-lines
- System-level ESD protection on CC lines as per IEC61000-4-2 level 4 ( $\pm 8$  kV contact discharge)
- Low power mode for battery operation allows zero current consumption when no cable is attached
- Integrated dead battery management for fully depleted battery devices
- Overtemperature protection (OTP)
- Compliant with the latest USB Type-C and USB power delivery standards
- Compliant with programmable power supply (PPS)

### Description

The X-NUCLEO-USBPDM1 is an expansion board for the [NUCLEO-G071RB](#) and [NUCLEO-G474RE](#) development boards or any [STM32 Nucleo](#) development board equipped with a USB Type-C™ peripheral.

It provides a straightforward means for evaluating USB Type-C™ Power Delivery in SINK mode based on [TCPP01-M12](#).

The USB Type-C connector can supply the [STM32 Nucleo](#) development board thanks to a 3.3 V LDO.

Product summary	
USB Type-C™ Power Delivery SINK expansion board based on TCPP01-M12 for STM32 Nucleo	<a href="#">X-NUCLEO-USBPDM1</a>
USB type-C port protection	<a href="#">TCPP01-M12</a>
High-power transient voltage suppressor (TVS)	<a href="#">ESDA25P35-1U1M</a>
Common-mode filter and ESD protection for USB 2.0 and MIPI/MDDI interfaces	<a href="#">ECMF02-2AMX6</a>
N-channel, STripFET H6 power MOSFET	<a href="#">STL11N3LLH6</a>
STM32 Nucleo-64 development boards with STM32G071RB/ STM32G474RE MCUs	<a href="#">NUCLEO-G071RB/ NUCLEO-G474RE</a>

Product summary	
Applications	Medical and Healthcare Power Supplies and Converters Smart Home USB Type-C and Power Delivery Wearable

# 1 Schematic diagrams

Figure 1. X-NUCLEO-USBPDM1 circuit schematic (1 of 2)

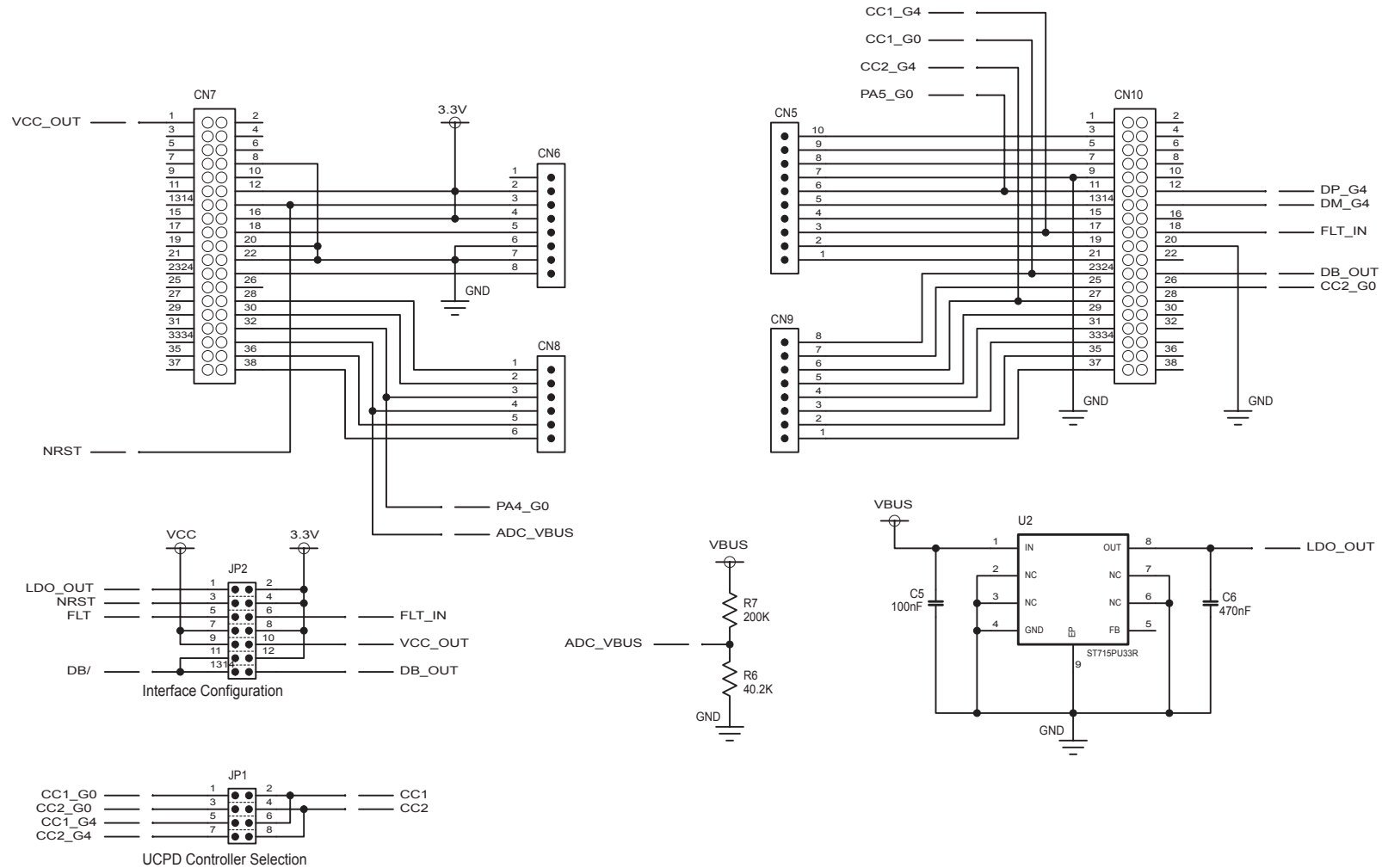
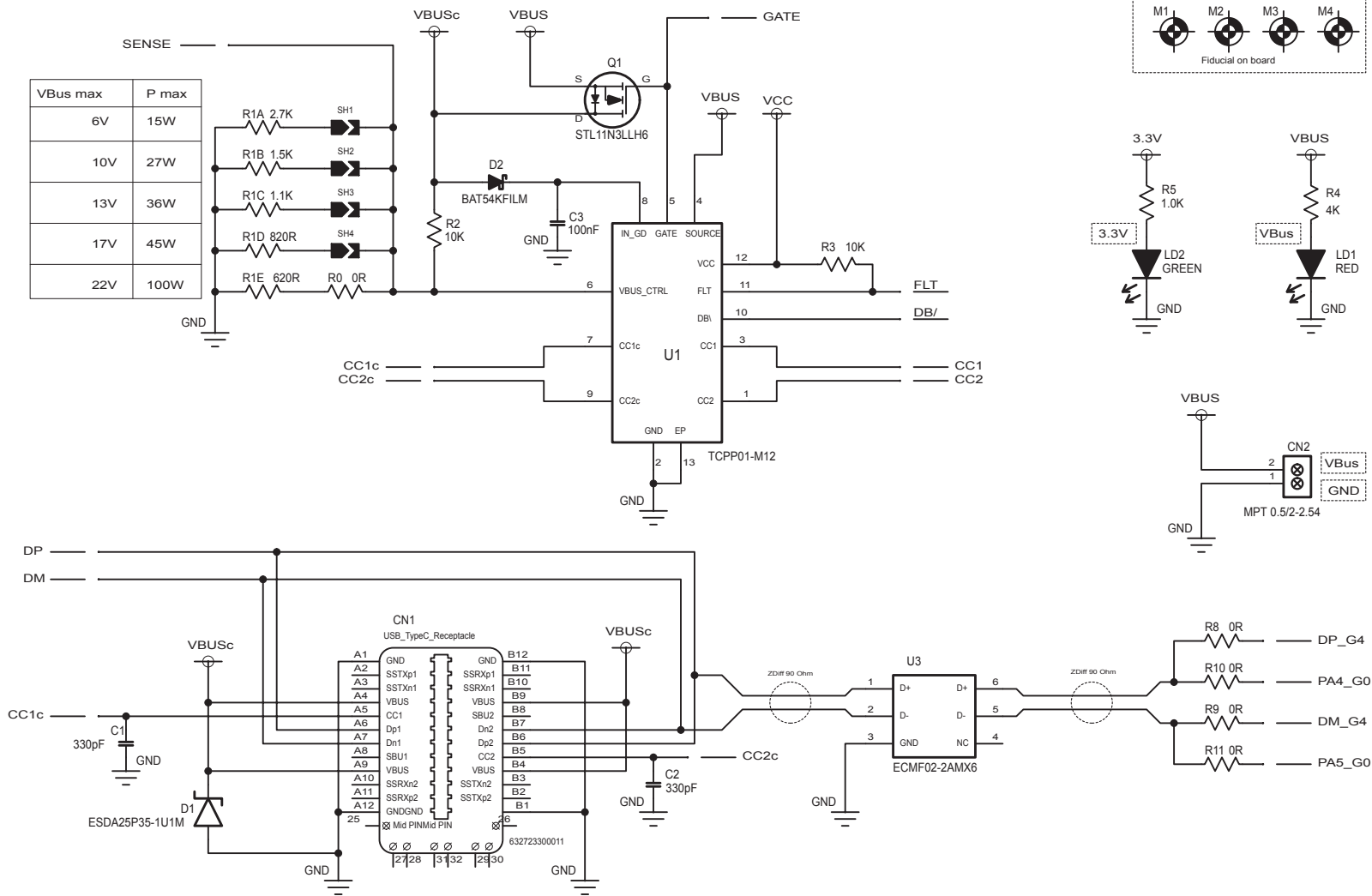

Figure 2. X-NUCLEO-USBPDM1 circuit schematic (2 of 2)



## Revision history

**Table 1. Document revision history**

Date	Version	Changes
06-Dec-2019	1	Initial release.

**IMPORTANT NOTICE – PLEASE READ CAREFULLY**

STMicroelectronics NV and its subsidiaries (“ST”) reserve the right to make changes, corrections, enhancements, modifications, and improvements to ST products and/or to this document at any time without notice. Purchasers should obtain the latest relevant information on ST products before placing orders. ST products are sold pursuant to ST’s terms and conditions of sale in place at the time of order acknowledgement.

Purchasers are solely responsible for the choice, selection, and use of ST products and ST assumes no liability for application assistance or the design of Purchasers’ products.

No license, express or implied, to any intellectual property right is granted by ST herein.

Resale of ST products with provisions different from the information set forth herein shall void any warranty granted by ST for such product.

ST and the ST logo are trademarks of ST. For additional information about ST trademarks, please refer to [www.st.com/trademarks](http://www.st.com/trademarks). All other product or service names are the property of their respective owners.

Information in this document supersedes and replaces information previously supplied in any prior versions of this document.

© 2019 STMicroelectronics – All rights reserved