

2 YEAR
WARRANTY



Ω OMEGA™ **User's Guide**



***Shop online at
omega.com***

e-mail: info@omega.com
***For latest product manuals:
www.omegamanual.info***

CN616A
Universal 6 Channel
1/4 DIN Process Controller



omega.com info@omega.com

Servicing North America:

**U.S.A.
Headquarters:**

Omega Engineering, Inc.

Toll-Free: 1-800-826-6342 (USA & Canada only)

Customer Service: 1-800-622-2378 (USA & Canada only)

Engineering Service: 1-800-872-9436 (USA & Canada only)

Tel: (203) 359-1660

Fax: (203) 359-7700

e-mail: info@omega.com

For Other Locations Visit omega.com/worldwide

Table of Contents, Figures and Tables

1.	Introduction	5
2.	Installation and Operating Conditions	6
3.	Mounting Instructions	7
4.	Wiring Instructions	8
4.1	Rear Panel Diagram	8
4.2	Connecting Power	9
4.3	Connecting Alarms	10
4.4	Connecting Communications	11
4.5	Connecting Inputs	11
4.6	Connecting Outputs	12
5.	CN616A Series Navigation.....	13
6.	Run Mode.....	13
6.1	Temperature/Process Display.....	14
6.2	Setpoint Display	14
6.3	Function Display	14
6.4	Lock Zone	14
6.5	Alarms.....	15
6.6	Reset Alarm.....	15
6.7	Factory Default Reset	15
7.	Programming Mode (Idle Mode).....	16
7.1	Function 99 – Password Entry.....	17
8.	Function Group 71 - Model Setup	17
8.1	Function 31 – Zone Enable	17
8.2	Function 32 – Password Enable	18
8.3	Function 33 – Input and Alarm Configuration	18
8.4	Function 34 – Modbus Address	19
8.5	Function 35 – Zone Display Time	19
8.6	Function 81 – Power-Up State	19
8.7	Function 82/83 – Alarm Relay Configuration.....	20
8.8	Function 84 – Serial Configuration.....	20
8.9	Function 85/86 – mA/mV High Scaling.....	21
9.	Function Group 72 – Setpoints and Alarms	22
9.1	Function 36 – Fixed Setpoint	22
9.2	Function 37/38 – Alarm Values.....	22
10.	Function Group 73 - Control Setup.....	23
10.1	Function 41 – Cycle Time.....	23
10.2	Function 42 – Hysteresis.....	23
10.3	Function 43 – PID Enable	24
10.4	Functions 44, 45, 46 – PID Gains	24
10.5	Function 47 – Control Direction	25
10.6	Function 48 – Control Mode	25
11.	Function 74 – Segment Control.....	26
12.	Function 75 – Segment Select.....	26
12.1	Functions 01-20 – Segment Edit	27
13.	Function 76 – Autotune Setpoint	28
14.	Function 77 – Run Autotune	28

15. Function 78 – Calibration	29
16. Function 79 – Start Profile	29
17. Reference Section	30
17.1 Alarms	30
17.2 PID Control	30
17.3 Autotune	31
17.4 Ramp & Soak	31
18. Communication Interface	31
18.1 Modbus Functions	32
18.2 Data Formats	32
18.3 Multiple Register Reads (FC03)	32
18.4 Multiple Register Writes (FC10)	33
19. Modbus Registers Listing	34
19.1 System Registers	34
19.2 Temperature Registers	35
19.3 Sensor Status Registers	35
19.4 Zone Registers	36
19.5 User Calibration	37
19.6 PID Registers	37
19.7 Profile Registers	39
20. Modbus Register Enumerated Values	40
20.1 Sensor Type	40
20.2 RTD Type	40
20.3 Thermocouple Type	40
20.4 Sensor Status	40
20.5 Decimal point	41
20.6 System State	41
20.7 Process Unit	41
20.8 Alarm Type	41
20.9 Alarm Status	41
20.10 Setting Toggle	41
20.11 Output Action	42
20.12 Control Mode	42
20.13 Control Method	42
20.14 Autotune Control	42
20.15 Segment State	42
20.16 Loop Status	42
21. Specifications	43
21.1 General	43
21.2 Alarm Relays	43
21.3 Input Accuracy	44
22. Approvals Information	45

1. Introduction

The CN616A Controller is a flexible, easy to use, six zone temperature and process control solution in a rugged ¼ DIN Aluminum housing. The universal input supports 9 thermocouple types (J, K, T, E, R, S, B, C, and N), 2 wire RTDs (Pt 100, Ni 120, Cu 10), DC voltage (0-1 Vdc), and DC current (0 – 24 mA). Both universal AC and Isolated DC power supply options are available and a user selectable RS232 or RS485 serial port interface is standard on all models. A security password can be enabled to prevent front panel tampering of the configuration and all options are software selectable eliminating the need to disassemble your panel to set jumpers.

The CN616A supports the measurement and control of 6 independent zones. Independent alarms are available for each zone and each alarm can be configured for above (HI), below (LO) or HI/LO triggering. Alarms conditions are indicated on the display and may be used to activate either of the 2 SPDT alarm outputs. All six zones are independently controlled. Users can select from On/Off, PID and Ramp & Soak control modes for each zone. Each zone can also be set to either Heating or Cooling allowing a wide range of applications in a single package. The auto-tune feature provides an easy way to setup initial control parameters.

2. Installation and Operating Conditions

This instrument is marked with the international Caution symbol. It is important to read and follow the Setup Guide before installing or commissioning this device. The Guide contains important information relating to safety and EMC.

The instrument is a device protected in accordance with UL 61010:2010 Electrical Safety Requirements for Electrical Equipment for Measurement, Control, and Laboratory. The device has no power-on switch. Installations must include a switch or circuit breaker that is compliant to IEC 947-1 and 947-3. It must be suitably located to be easily reached and marked as the disconnecting device for the equipment.

WARNING: Do NOT connect AC power to your device until you have completed all input and output connections. This device is a panel mount device protected in accordance with Class I of EN 61010 (115 / 230 AC power connections), Class III for the DC power option (9-36Vdc). It must be installed by a trained electrician with corresponding qualifications. Failure to follow all instructions and warnings may result in injury.

Use copper conductors only, minimum 20 AWG, UL Rated, for power and outputs. Insulation must be rated for at least 85°C and 600V.

This device is not designed for use in, and should not be used for, patient-connected applications.

SAFETY:

- Do not exceed the voltage rating on the label located on the device housing.
- Always disconnect power before changing signal and power connections.
- Do not operate this instrument in flammable or explosive atmospheres.
- Do not expose this instrument to rain or moisture.

EMC:

- Whenever EMC is an issue use shielded cables.
- Never run signal and power wires in the same conduit.
- Use signal wire connections with twisted-pair cables
- If EMC problems occur, Install Ferrite Bead(s) on signal wires close to the instrument.



WARNING: Failure to follow all instructions and warnings is at your own risk and may result in property damage, bodily injury and/or death. Omega Engineering is not responsible for any damages or loss arising or resulting from any failure to follow any and all instructions or observe any and all warnings.



CAUTION: Risk of electric shock. Disconnect all power sources before servicing.

3. Mounting Instructions

Select a location for the monitor that is free from excessive shock, vibration, dirt, moisture, and oil. Mount the monitor into a 3 5/8" (92mm) square cutout. The monitor as shipped is 1/4 DIN (92mm square), so it does not have to be removed from the housing to be mounted. Remove the two screws that secure the mounting slides. Remove the slides and insert the case into the cutout from the front side of the panel. Reinstall the two slides and two screws. The length of the slides must be reduced if the monitor is to be mounted in an extra thick panel.

Ensure that the unit is properly grounded to the panel which should be earth grounded. Use the supplementary ground point indicated on the rear panel if a good ground connection cannot be maintained from the mounting slides alone.

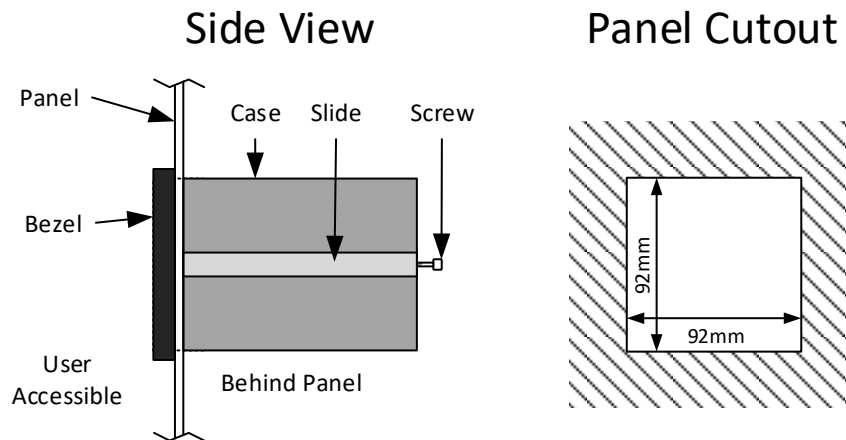

Figure 1 – Side and Panel Cutout Views

4. Wiring Instructions

4.1 Rear Panel Diagram

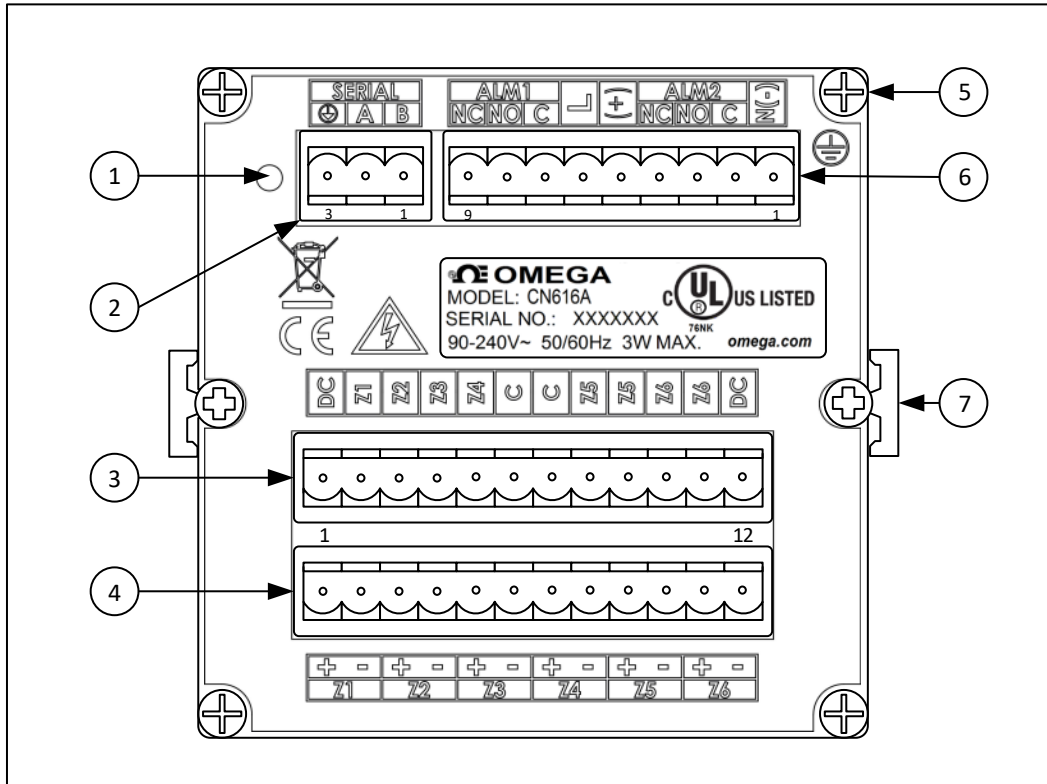

Figure 2 – CN616A: Rear Panel Connections

Item	Description
1	Reset Pinhole
2	Serial Connector
3	Output 1 through 6
4	Input 1 through 6
5	Supplementary Ground Point
6	Power and Alarm Connector
7	Mounting Slide

Table 1 – Rear Panel Connections



CAUTION: Use only provided terminals. Torque all connections to 0.5 – 0.6Nm.

4.2 Connecting Power

Pin No.	Code	Description
1	N(-)	Neutral Power / DC – Power supply
2	ALM2 C	Alarm Relay 2 Common
3	ALM2 NO	Alarm Relay 2 Normally Open
4	ALM2 NC	Alarm Relay 2 Normally Closed
5	(+)	DC + Power supply (9-36VDC)
6	L	Line Power (90-240VAC)
7	ALM1 C	Alarm Relay 1 Common
8	ALM1 NO	Alarm Relay 1 Normally Open
9	ALM1 NC	Alarm Relay 1 Normally Closed

Table 2 - 9-Pin Input Power / Relay Wiring Summary

Connect the main power connections to pins 4 and 9 (AC Power) or pins 5 (+) and 9 (-) (DC Power) of the 9pin power / output connector as shown in **Figure 3**.

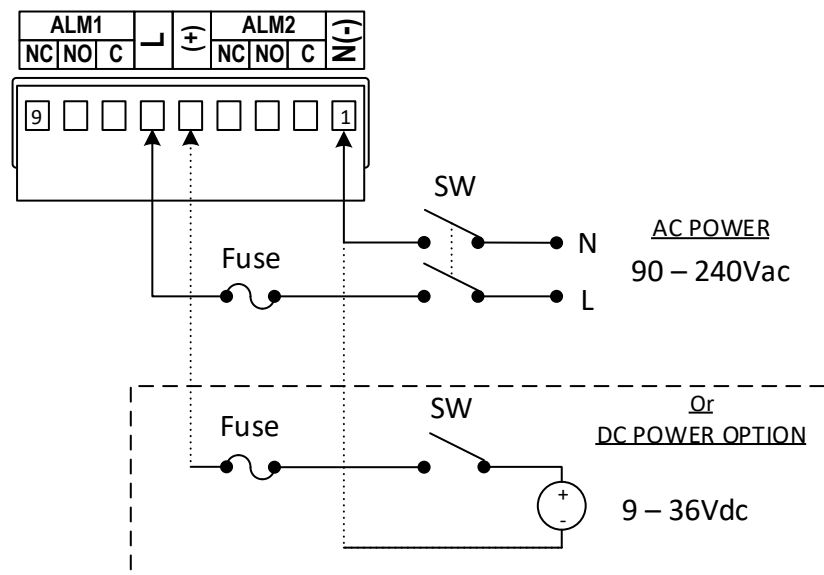

Figure 3 - Main Power Connections



For the low-voltage power option, maintain the same degree of protection as the standard high-voltage input power units (90–240 Vac) by using a Safety Agency Approved DC source with the same Overvoltage Category and pollution degree as the AC model.

The Safety European Standard EN61010-1 for measurement, control, and laboratory equipment requires that fuses must be specified based on IEC127. This standard specifies the letter code “T” for a Time-lag fuse.

4.3 Connecting Alarms

The CN616A includes SPDT mechanical relays with internal snubbers on the normally open (NO) contact side. When powered and not in an alarm state the relays are energized and the NO contact is connected to the Relay common contact. If an alarm condition occurs or if the unit loses power the relay is deenergized and the normally closed (NC) contact is connected to the Relay common contact.

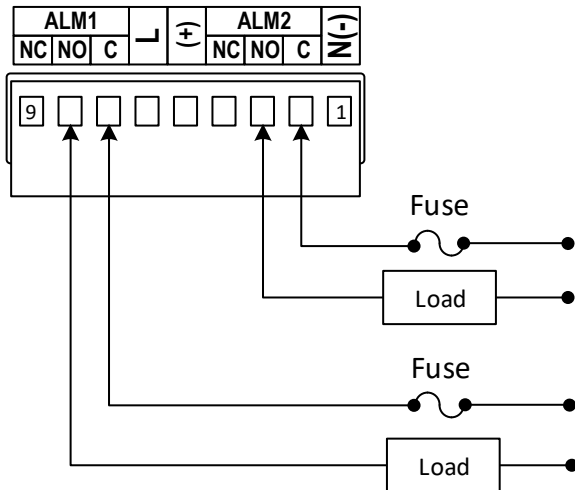

Figure 4 – Relay Connections

! For the low-voltage power option, maintain the same degree of protection as the standard high-voltage input power units (90–240 Vac) by using a Safety Agency Approved DC or AC source with the same Overvoltage Category and pollution degree as the standard AC unit (90–300 Vac).

The Safety European Standard EN61010-1 for measurement, control, and laboratory equipment requires that fuses must be specified based on IEC127. This standard specifies the letter code “T” for a Time-lag fuse.

Table 3 – Fuse Values

Input Power	Input Fuse	Alarm Fuse
115Vac	25mA	5A
230Vac	25mA	5A
9-36VDC	300mA	3A

4.4 Connecting Communications

Pin No.	Code	Description
1	B	RS485 B signal, RS232 TX (to remote device)
2	A	RS485 A signal, RS232 RX (from remote device)
3	⊕	RTN signal for serial communications

Table 4 – Connecting Communications

Note: The RTN signal is isolated from the Signal RTN and the Power ground.

4.5 Connecting Inputs

Pin No.	Code	Description
1	Z1 +	Zone 1 Positive Input
2	Z1 -	Zone 1 Negative Input
3	Z2 +	Zone 2 Positive Input
4	Z2 -	Zone 2 Negative Input
5	Z3 +	Zone 3 Positive Input
6	Z3 -	Zone 3 Negative Input
7	Z4 +	Zone 4 Positive Input
8	Z4 -	Zone 4 Negative Input
9	Z5 +	Zone 5 Positive Input
10	Z5 -	Zone 5 Negative Input
11	Z6 +	Zone 6 Positive Input
12	Z6 -	Zone 6 Negative Input

Connect Input sensors to the terminals Marked Zone 1 through Zone 6 (Z1 – Z6) on the rear panel.

When connecting sensors follow the polarity indicated on the rear panel:

- For Thermocouples the Negative wire is Red (NA) or White (IEC 584-3).
- For Process Inputs the Negative terminal is return/ground.
- RTDs may be connected in either orientation.

Note that all input terminals share a common internal ground connection. Ensure that all sensors share a common ground or are fully isolated.

4.6 Connecting Outputs

Pin No.	Code	Description
1	DC	5V Output
2	Z1	Zone 1 Open Drain Output
3	Z2	Zone 2 Open Drain Output
4	Z3	Zone 3 Open Drain Output
5	Z4	Zone 4 Open Drain Output
6	C	Common
7	C	Common
8	Z5	Zone 5 Open Drain Output
9	Z5	Zone 5 Open Drain Output
10	Z6	Zone 6 Open Drain Output
11	Z6	Zone 6 Open Drain Output
12	DC	5V Output

The CN616A has 6 Common Drain outputs intended to drive external SSRs. The outputs are Active Low and require an external pullup. Each output is rated for 3.3Vdc to 36Vdc. An internal 5Vdc supply is available for convenience and is rated for 25mA per channel. Refer to the diagram below for the most common connection options.

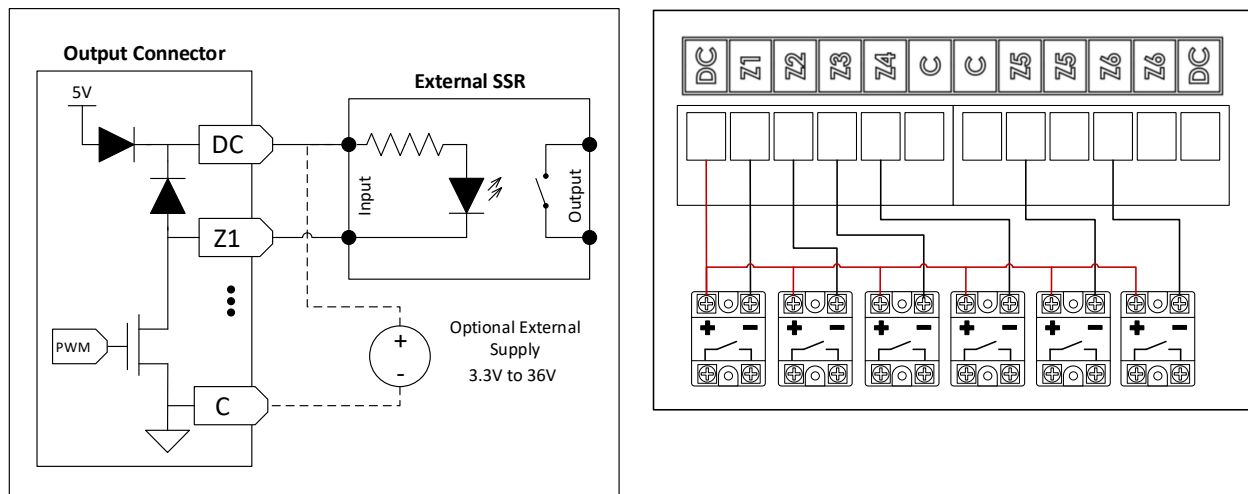

When using an optional external power supply:

- If the power supply is less than 5V do not connect to the DC terminals of the output connector as this may cause back feeding of the power supply.
- Note that the Common terminals connect to the input ground. Ensure the inputs and the power supply share a common ground or are fully isolated.

5. CN616A Series Navigation

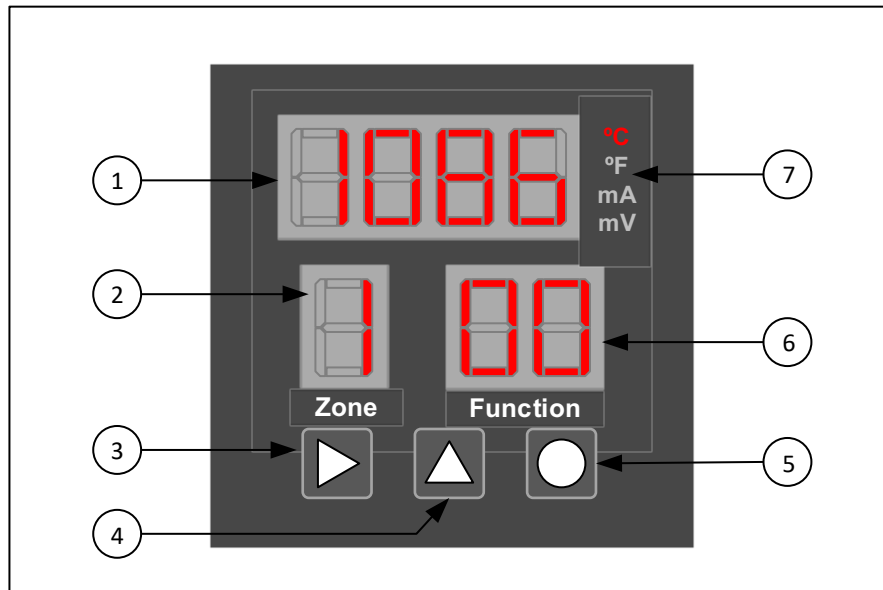

Figure 5 – Front Panel Diagram

Item	Description
1	Main Display
2	Zone Display
3	Advance Button
4	Increment Button
5	Select Button
6	Function Display
7	Unit/Mode Indicator

6. Run Mode

When power is applied to the unit it automatically enters run mode by default. This behavior can be changed by changing the Power-up state set in Start-up Parameters.

In run mode, the controller sequentially scans through all active zones at the user determined scan rate. The process temperature is shown on the main display. The zone display indicates the current scanning zone and the function display indicates the control mode and/or any alarms or errors.

Each zone is independent and can be set to On/Off, PID, Ramp & Soak, or Disabled. The direction of control is set using the Control Direction menu and defaults to Reverse (Heating). During run mode the outputs are enabled for all active zones.

Alarms can be configured separately for any zone and are active while in Run mode. Alarm conditions are indicated by flashing the function display.

6.1 Temperature/Process Display

The default display option is Temperature/Process display. The controller scans through active zones and updates process value in the main display. The zone number is shown in the Zone display. Press  to jump to the next active zone.

6.2 Setpoint Display

To enable Setpoint Display, Press and hold  to switch to Setpoint display. The controller shows the Setpoint on the main display. The zone digit flashes to indicate main display is in Setpoint Display mode. Releasing the button returns the display to normal operation. All control including Ramp and Soak continue during this time. If the zone is running Standard control the fixed Setpoint defined in Function 36 is displayed. If the zone is running Ramp & Soak the target setpoint for the current segment is displayed.



6.3 Function Display

In run mode, function display indicates the control mode and states of the currently displayed zone. Refer to the following table:

Function Code	Description
00	Standard control with a Fixed Setpoint
01 to 20	Ramp Soak control, active segment 1 to 20
51	Ramp Soak control, idle state (end of profile)
52	Ramp Soak control, holding state (end of profile)
61	Autotune Stage 1 (30% progress)
62	Autotune Stage 2 (60% progress)
63	Autotune Stage 3 (90% progress)
88	Sensor is invalid or out of range.

Table – Run Mode function codes

6.4 Lock Zone





In Run mode, zone scanning can be disabled to prevent temperature display from cycling. Press  to lock a zone. Press  to unlock and resume zone scanning.

If any zone has an alarm condition, zone scanning will resume automatically and locking of zones is disabled.



6.5 Alarms

When any alarm or error occurs in Run mode the reading flashes when displaying a zone with an Alarm. To ensure that all alarms are displayed, the display cannot be locked when there is an alarm and unit will resume scanning if it was locked. If a low alarm is triggered the fright digit of the Function display flashes. If a high alarm is triggered the left digit of the function code flashes. Refer to Alarms reference section for more information.



6.6 Reset Alarm

In Run mode, alarm conditions may be reset by pressing   together. All latched alarms are cleared and the unit enters the Programming menu. Press   together again to return to run mode and resume alarm monitoring.

6.7 Factory Default Reset

At any time, the unit can be reset to the factory default configuration by holding down    for 5 seconds. The unit reboots and returns to the run mode. All user settings including Password and PID settings are lost.

7. Programming Mode (Idle Mode)





Programming Mode may be entered from Run Mode by pressing   together. The Programming Mode (Idle state) can also be entered remotely by the System State Modbus command.



While In the programming mode alarm triggers are reset and control outputs are turned off for all zones. Any Ramp and Soak timers for currently running segment are paused and will resume when exiting.

Function	Description	Function	Description
70	Function Select		
71	Model Setup Group	73	Control Setup
31	Zone Enable	41	Cycle Time
32	Password Enable	42	Hysteresis
33	Input and Alarm Configuration	43	PID Enable
34	Modbus Address	44	Proportional Gain
35	Zone Display Time	45	Integral Gain
81	Power-Up State	46	Derivative Gain
82	Alarm Relay 1	47	Control Direction
83	Alarm Relay 2	48	Control Mode
84	Serial Configuration	74	Segment Control
85	mA/mV Low Scaling	75	Segment Edit
86	mA/mV High Scaling	##	Segment ## (01 to 20)
72	Setpoints and Alarms	76	Autotune Setpoint
36	Absolute Setpoint	77	Run Autotune
37	High Alarm Setpoint	78	Calibration
38	Low Alarm Setpoint	79	Start Profile

Table – Programming menu function code

When entering the programming mode the function display shows 70. The desired menu function is displayed in the main display. Navigate the menu by using the front panel buttons below.

	Increment the desired Function selection.
	Enter the Function selected in the Main display.
 	Go up one level in the menu or return to Run Mode.



Menu items 71, 72, 73 and 75 are divided into several sub-menus for easier navigation. When entering a sub-menu, the top-level menu is shown in the function display and the desired sub-menu selection is shown in the Main display. Pressing   together will always return to the beginning of the next higher-level menu.

7.1 Function 99 – Password Entry

When password protection is enabled the programming menu will not be available until the device password is entered. This prevents unintended changes to the device's programming. When an incorrect password is entered the unit returns to Run Mode.

The default password is 1011 and the password can be changed over Modbus only. If the password is lost it can be reset to the default password by resetting the unit to defaults.

Note: Resetting the unit to defaults will wipe out any user programming.

	Increment the flashing digit of Main display
	Selects the next digit of Main display, causing it to flash
	Submit the entered password to unlock programming menus.





8. Function Group 71 - Model Setup

Function group 71 configures the basic device operation including inputs, display, communications and alarms. On entering, the Function display shows 71 and the Main display shows the first available function, Function 31.

8.1 Function 31 – Zone Enable



Function 31 selects which zones are available for scanning and control. By default all zones are enabled. When a zone is disabled it will not be shown on the front panel, its output will be disabled and no alarms will trigger for that zone.

The Function display will show 31. The ZONE display will show selected zone and the Main display will be blank. A flashing Zone display indicates that the selected zone is disabled. A Solid Zone display indicates that the selected zone is enabled.

	Save the current zone and advance to the next zone.
	Toggles the current zone between <i>enabled</i> (solid) or <i>disabled</i> (flashing).
	Save the setting and return to the Model Setup menu.
	Return to the Model Setup menu without saving.





8.2 Function 32 – Password Enable

Function 32 enables or disables password protection. Password protection may be set to prevent unauthorized changes to the unit programming. By default password protection is disabled. The function display shows 32 and the Zone display is blank and the Main display indicates if password protection is enabled or not. A '0' indicates password protection is disabled and a '1' indicates it is enabled.

	Toggles enable/disable password protection
	Save the setting and return to the Model Setup menu.
	Return to the Model Setup menu without saving.

8.3 Function 33 – Input and Alarm Configuration

Function 33 sets the Input type, Display units and Alarm configuration. The default setting is 2204 which represents Thermocouple Type K inputs with High/Low Latching alarms in Degrees Celsius. Each digit in the Main Display represents a different function. Refer to the table below for the specific functions.

	Advance to the next digit of the available configurations.
	Selects the next digit of Main display, causing it to flash.
	Save the setting and return to the Model Setup menu.
	Return to the Model Setup menu without saving.





Digit 1 Alarm type		Digit 2		Digit 3 Input		Digit 4				
		Relay	Unit			TC	RTD	Decimal Pt		
0	High Alarm	0	Latch	C	0	TC	0	B	Pt100	0
1	Low Alarm	1	Latch	F	1	RTD2	1	C	Ni120	1
2	High-Low Alarm	2	Non-latch	C			2	E	Cu10	2
3	No Alarm	3	Non-latch	F	3	mA	3	J		
4	User Defined				4	mV	4	K		
							5	R		
							6	S		
							7	T		
							8	N		

Please note: Digit 4 is dependent upon the "Input Type" selected under Digit 3. Ex: If "TC" is selected under "Input Type" under Digit 3, Digit 4 becomes one of the following "B, C, E, J, etc." under "TC Type."

8.4 Function 34 – Modbus Address

Function 34 sets the Modbus Address which used to communicate with multiple units using one RS485 port. The default Modbus address is 1 and any address from 1 to 255 can be used. Each unit connected to the same bus must have a unique Modbus address.





The Function display shows 34 and the Zone display will be blank. The Main display shows the Modbus Address in decimal format. The first digit flashes to indicate it can be edited. Use the buttons below to edit the address. Trying to enter a number greater than 255 will cause the display to roll back to a valid number.

	Increment the flashing digit of the Main display.
	Selects the next digit of the Main display, causing it to flash.
	Save the setting and return to the Model Setup menu.
	Return to the Model Setup menu without saving.

8.5 Function 35 – Zone Display Time

Function 35 sets the time duration that the Main display will show the current zone temperature before moving to the next zone. The default time 3 seconds and it is adjustable from 1 to 99 seconds.



The Function display shows 35 and the Zone is blank. The Main display shows the current Zone Display Time with the first digit flashing.

	Increment the flashing digit of the Main display
	Selects the next digit of the Main display, causing it to flash
	Saves the setting and return to the Model Setup menu.
	Return to the Model Setup menu without saving.

8.6 Function 81 – Power-Up State

Function 81 sets how the unit behaves when it is first powered on. By default the unit powers on and immediately enters the Run state executing the control and/or Ramp and Soak program that is loaded. The unit can also be set to power up in the Idle state where it will wait for a user to enter the Run state.

The Function display shows 81 and the Zone display is blank. The Main display shows the current power up state. A '0' indicate the Idle state while a '1' indicates Run mode.

	Increment the flashing digit of the Main display.
	Save the setting and return to the Model Setup menu.
	Return to the Model Setup menu without saving.

8.7 Function 82/83 – Alarm Relay Configuration

When the alarm type is set to *user defined* in Function 33, Functions 82 and 83 configure the behavior of the alarm relays. This allows for different alarms to be assigned to each relay and different alarm types to be assigned to each channel.

Function 82 controls Alarm relay 1 and Function 83 Controls Alarm Relay 2. By Default, Alarm 1 is assigned high / low alarms for all zones and Alarm 2 is Disabled for all zones. Refer to the chart below to determine the desired configuration. See alarm conditions for more information on setting up alarms.





	Increment the flashing digit of the Main display.
	Selects the next digit of the Main display, causing it to flash.
	Save the current zone settings and load the next zone.
	Return to the Model Setup Menu without saving.





Table – Alarm Settings

Digit 1		Digit 2		Digit 3		Digit 4	
		0	High Alarm	0	No		
		1	Low Alarm	1	Yes		
		2	High Low Alarm				
		3	No Alarm				

8.8 Function 84 – Serial Configuration

Function 84 sets the serial port configuration on the unit. The port can be configured as either RS232 or RS485 and supports most common data rates. The default settings are RS485, 115.2kbaud, No Parity.

The Function display shows 84 and the Zone display is blank. The Main display shows the current configuration with the first digit flashing.

	Increment the flashing digit of the Main display
	Selects the next digit of the Main display, causing it to flash.
	Save the setting and return to the Model Setup menu.
	Return to the Model Setup menu without saving.

Digit 1		Digit 2		Digit 3		Digit 4	
0	RS485	0	4800	0	None	0	
1	RS232	1	9600	1	Odd		
		2	19200	2	Even		
		3	38400				
		4	57600				
		5	115200				





Table – Serial configuration

8.9 Function 85/86 – mA/mV High Scaling

Functions 85 and 86 set the scaling for the mA and mV inputs. Function 85 sets the high scale and Function 86 sets the low scale. The scaling factors for mA and mV are separate so the values corresponding to the input type selected in Function 33 are shown.

By default, the scaling is set to display the measurement in mA/mV.

Scaling factors are applied independently for each zone. The current zone being modified is displayed in the Zone Display. Enter the value to be displayed at 4mA or 0V in Function 85 and the value to be displayed at 20mA or 1V in function 86. Values between the two points are linearly interpolated.

	Increment the flashing digit.
	Selects the next digit, causing it to flash.
	Moves the decimal point to the right.
	Save the current zone settings and load the next zone.
	Return to Model Setup menu without saving.

Note: It is possible to set the scaling factors so that the unit reads greater than 9999 or less than -999. In this case the unit will display ---- indicating it is unable to display the value of the measurement. In this case control will continue normally and the actual value will be reported over Modbus.

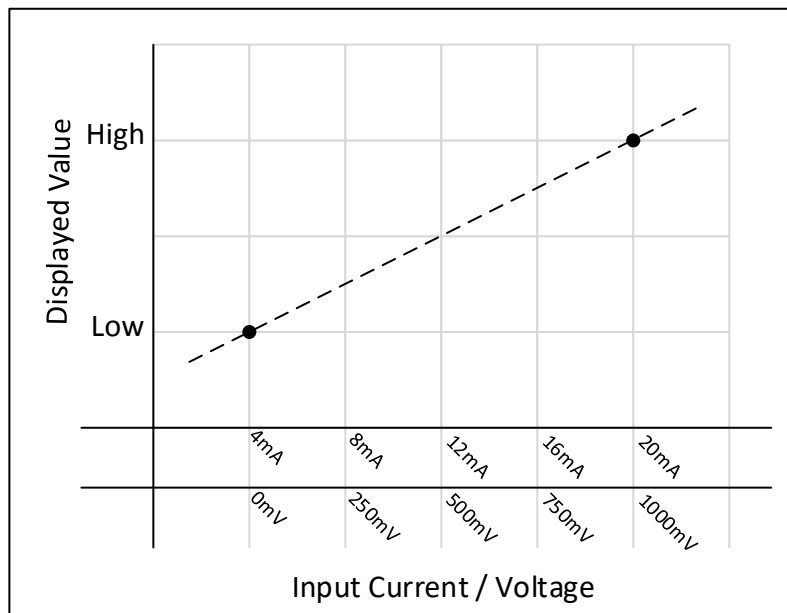

Figure 6 – Process Input Scaling

9. Function Group 72 – Setpoints and Alarms





Function Group 72 configures Fixed Setpoints and Alarms values for the unit. All Setpoints and Alarm values are unique for each zone. The Function display shows 72 and the Main display shows the first available function, function 36.

9.1 Function 36 – Fixed Setpoint

Function 36 sets the setpoints for all zones running in standard control mode. By default, all zone are set to run in standard mode, which provides a fixed setpoint. If the zone is set to Ramp/Soak control the Fixed Setpoint is ignored. The control mode can be set using Function 48.

The default setpoint for all zones is 0 and applies to both On/Off and PID control modes.





The function display shows 36 and the Zone display shows the current zone being edited. The Main display shows the Setpoint of the selected zone.

	Increment the flashing digit of the Main display
	Selects the next digit of the Main display, causing it to flash.
	Move the decimal point to the right.
	Save the current zone settings and load the next zone.
	Return to Control Setup menu without saving.

9.2 Function 37/38 – Alarm Values

Functions 37 and 38 control the High and Low alarm values respectively. These values are independent for each zone. By default, all High alarms are set to 9000 and all Low alarms are set to -900. An alarm will not trigger if the Zone is Disabled or if the Alarm mode for that zone is disabled. The High value is ignored for zones set for low alarming and vice versa.

The function display shows 37 and the Zone display will show the current Zone being edited. The Main display will show the Alarm Value with the first digit flashing.

	Increment the flashing digit of the Main display
	Selects the next digit of the Main display, causing it to flash
	Move the decimal point to the right
	Save the current zone settings and load the next zone.
	Return to Control Setup menu without saving.





10. Function Group 73 - Control Setup

Function group 73 configures the PID Control parameters and configures other control parameters such as control direction, type of control, PWM Cycle time and hysteresis. The Function display shows 73 and the Main display shows the first available function, function 41.

10.1 Function 41 - Cycle Time

Function 41 sets the output cycle time when running in PID mode. The PID output controls the percentage of this cycle time that the output is activated. All zones share the same cycle time and the default time is 5 seconds.

The function display shows 41 and the ZONE display is blank. The Main display shows the Output Cycle Time in seconds. The cycle time may be set from 0.1s to 99.9s.





	Increment the flashing digit of the Main display.
	Selects the next digit of the Main display, causing it to flash.
	Save the setting and return to the Control Setup Menu.
	Return to the Control Setup Menu without saving.

10.2 Function 42 - Hysteresis

Function 42 controls the Hysteresis when operating in both Standard Control and Ramp and Soak mode. The hysteresis sets the deviation above and below the setpoint where the control does not change. The hysteresis for each zone is independent.

When operating in On/Off mode the output will only switch at (Setpoint + Hysteresis) and (Setpoint – Hysteresis). When operating in PID mode the PWM value remains fixed between (Setpoint + Hysteresis) and (Setpoint – Hysteresis). Hysteresis is disabled when set to '0' and all zones are set to '0' by default.





The function display shows 42 and the Zone display shows the zone being edited. The Main display shows Hysteresis in the current process units.

	Increment the flashing digit of the Main display.
	Selects the next digit of the Main display, causing it to flash.
	Move the decimal point to the right.
	Save the current zone settings and load the next zone.
	Return to the Control Setup menu without saving.

10.3 Function 43 – PID Enable

Function 43 selects between PID and On/Off Control mode. Each zone has an independent setting allowing for mixed operation. By default all Zones are set to On/Off Control.

The function display shows 43 and the Main display is blank. The Zone display shows the currently selected zone. If the Zone display is flashing On/Off control is selected and if it is solid PID control is selected.





	Save the current zone and advance to the next zone.
	Toggle the zone setting, a <i>flashing digit</i> indicates On/Off control, a <i>solid digit</i> indicates PID control
	Save the settings and Return to the Control Setup menu.
	Return to the Control Setup menu without saving.

10.4 Functions 44, 45, 46 – PID Gains

Function 44 sets the Proportional Gain, Function 45 Sets the Integral Gain and Function 46 sets the Derivative gain for each zone. Each zone has its own set of independent control parameters and by default $P = 1$, $I = 0$ and $D = 0$ for all zones. These settings will provide only minimal output for most applications so must be changed before operation. Integral and Derivative gains are referenced over 1 second.

Proportional Gain causes the output power to be set in proportion to the error between Control Setpoint and process value. Integral Gain adjusts the output power based on the cumulative error. The proportional gain produces a fixed output for a fixed error while the integral gain produces a changing output based on a fixed error. Derivative Gain adjusts the output power based on the rate the process moves. The CN616A provides an integrated Autotune function to help determine the PID settings automatically. Please refer to Sections 17.2 and 17.3 for more information on PID control and Autotuning.





The Function and Zone displays shows the current gain being edited. The Main display shows the Gain for the selected zone.

	Increment the flashing digit of the Main display
	Selects the next digit of the Main display, causing it to flash
	Move the decimal point to the right
	Save the current zone settings and load the next zone.
	Return to the Control Setup menu without saving.

10.5 Function 47 – Control Direction

The Control direction function allows each zone to be set to either Reverse (Heating) or Direct (Cooling) Control. By default, all zones are set to Reverse (Heating).



The Function display shows 47 and the Main display is blank. The ZONE display shows the zone being edited. If the Zone display is flashing Direct control is selected and if it is solid Reverse control is selected.

	Save the current zone and advance to the next zone.
	Toggle the zone setting. A <i>flashing digit</i> indicates Direct (Cooling). A <i>solid digit</i> indicates Reverse (Heating).
	Save the settings and Return to the Control Setup menu.
	Return to the Control Setup menu without saving.

10.6 Function 48 – Control Mode

Function 48 selected between Standard control, using the Fixed Setpoint, and Ramp and Soak control. By default, all zones are set to Standard Control. Ramp and Soak control has the option to either Stop and turn off all outputs after the program is finished or to Hold the last temperature.

The Function display shows 48 and the Zone display shows the selected zone. The Main display shows control mode for the selected zone.





	Increment the flashing digit of the Main display
	Save the current zone settings and load the next zone.
	Return to the Control Setup menu without saving.

Function 48	
0	Standard
1	Ramp & Soak then Stop
2	Ramp & Soak then Hold

11. Function 74 – Segment Control

Function 74 sets the number of segments in the Ramp and Soak profile of each zone. The default number of segments is 1 and up to 20 segments are available for each zone. If the number of segments is set to 0 ramp and soak is disabled on that zone and it will run in Standard control mode using the Absolute Setpoint defined in Function 36.



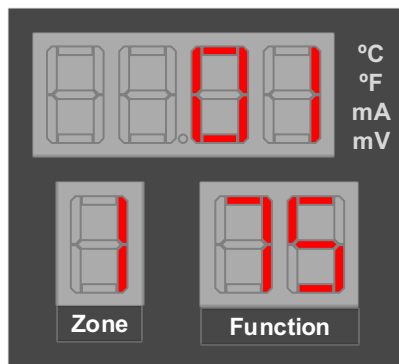

The function display shows 7 and the Zone display shows the currently selected zone. The Main display shows the number of available Ramp & Soak segments for the selected zone.

	Increment the flashing digit of the Main display.
	Selects the next digit of the Main display, causing it to flash.
	Save the current zone settings and load the next zone.
	Return to the Function Select Menu without saving.

12. Function 75 – Segment Select



Function 75 selects the ramp and soak segment to edit and functions slightly differently from the other menus. Initially the Zone display shows the desired zone to edit and the Main display shows the desired segment to edit. Pressing  button will switch between editing the Segment number and Editing the Zone number. For each zone, only the number of segments set in Function 74 can be edited.

	Increment the flashing digit.
	Advance to the next digit or switch to zone select.
	Edit the selected Segment.
	Return to the Function Select Menu.

12.1 Functions 01-20 – Segment Edit

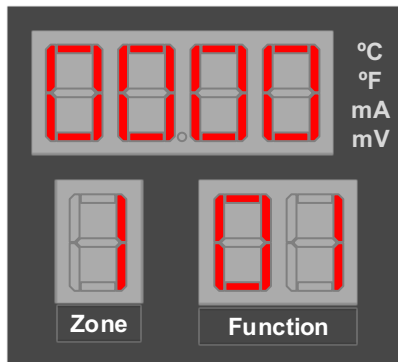

After selecting which segment to edit the unit transitions to Segment Edit Mode. The Zone display shows the Zone selected and the Function Display shows the segment selected. Initially these are set to the values selected in Function 75 to allow for easier editing of large profiles.

Each Segment consists of a Setpoint a Slope and a Time. The Main display initially shows the Setpoint for the selected segment. Pressing scrolls through the digits of the setpoint and then cycles to the Slope and finally the Time. By default, the Setpoint and Slope are zero and the Time is 1 hour.

To distinguish different parameters, each display is formatted with different digit counts and decimal points.

- The Setpoint display has 4 digits with no decimal point (**9999 counts**).
- The Slope display has 3 digits with 1 decimal point (**99.9 counts/minute**).
- And the Time display has 4 digits with 2 decimal point (**99.99 hours**).

Pressing saves the current segment and loads the next segment for the current zone. If there are no more segments in the current zone the first segment of the next zone will be loaded.

	Increment the flashing digit.
	Advance to the next digit of current display or cycle to the next display
	Save the current segment settings and load the next segment.
	Return to the Function Select Menu without saving.

The first segment in a profile is always a Ramp from the current temperature to the first Setpoint. This may be done at a fixed Rate (Slope) or a fixed Time. Following segments can either Ramp or Soak.





To Soak, set the next Setpoint to be the same as the previous Setpoint and set the Slope to Zero. Enter the Soak time into the Time field.

To Ramp, set the next setpoint to be different than the previous setpoint. A Ramp may be specified with either a Time or a Slope. To specify a Ramp Time leave the Slope as zero. If both Slope and Time are set time is ignored. The Slope is always specified as a positive number. If the next setpoint is less than the current setpoint, the Ramp will automatically be calculated as a negative.

Note: When a profile is running new segments are only loaded at the end of the previous segment. Editing a running segment does not change the currently running profile. Changes to future segments will take place as soon as they are reached.



13. Function 76 – Autotune Setpoint

The Autotune Setpoint is the process value at which the auto-tuning will take place. The function display shows 76. The Zone display shows the selected zone and the Main display shows the Autotune Setpoint for the selected zone.

	Increment the flashing digit of the setpoint display.
	Selects the next digit of the Main display, causing it to flash.
	Move the decimal point to the right.
	Save the current zone settings and load the next zone.
	Return to the Function Select Menu without saving.

14. Function 77 – Run Autotune

Function 77 activates Autotune for a selected zone. The function display shows 77. The Zone display shows the zone number and the Main display shows the autotune setpoint for the selected zone set in Function 76.

	Select the zone to auto-tune.
	Start the auto-tune. Returns to Run mode once complete.
	Stop the auto-tune and Returns to the Function Select Menu.



When running autotune the process value is shown in the Main display and the progress is shown in the Function display. The display blinks when the output is active and is solid when the output is off. The Function display shows 61, 62, 63 to indicate the auto-tune progress. When auto-tune is completed, the unit automatically runs to Run mode.

15. Function 78 – Calibration

Note: *This menu will only show when RTD sensor is select in Model Select menu.*

The CN616A is factory calibrated and do not require additional user calibration under most circumstances. For 2 wire RTDs Function 78 may be used to calibrate out lead wire resistance. This calibration is done independently for each channel.

To perform lead wire calibration short the RTD that needs to be calibrated at the end of the lead wire. Next select the Zone to be calibrated in the primary Display using the increment button. Press the select button to perform the calibration. While the unit is calibrating the Zone flashes to indicate it is busy. Once the calibration is complete the Zone will stop flashing. If the lead wire resistance is more than 10 ohms the unit will display "FAIL" and the calibration value will be set to 0.





	Scroll to next zone.
	Perform Calibration on current zone.
	Return to the Function Select Menu.

16. Function 79 – Start Profile

Function 79 selects which Ramp and Soak profiles are running and is used to Stop or Restart a profile. The Function displays shows 79 and the Zone display is blank. The Main display shows the status of each zone. A flashing digit indicates Ramp & Soak is disabled and a solid digit indicates Ramp & Soak is enabled.

There are two short-cuts provided for Convenience:

- Select 0 to Stop Ramp & Soak on all zones.
- Select 7 to Start Ramp & Soak on all zones.

	Select the next zone on the main display.
	Toggle the digit of the main display. A <u>flashing digit</u> indicates Ramp & Soak is disabled and a <u>solid digit</u> indicates Ramp & Soak is enabled.
	Save Settings and Return to RUN mode.
	Return to the Function Select Menu without saving.

17. Reference Section

17.1 Alarms

Each zone can configure two independent alarms. Alarms can be set as High, Low, or both High and Low. The Alarm High setpoint and Low setpoint apply to both Alarm Relays. The alarm relay is energized when the unit is powered on and de-energized when an alarm is triggered. The Alarm relay is energized again when all alarms are cleared or when the unit enters Programming mode.

The CN616A has several features to prevent false and nuisance alarms. Alarms due to high or low process value feature a delayed trigger to prevent false alarms due to process noise however Alarms due sensor burnout always trigger immediately.

When an alarm condition is met, the corresponding Alarm relay output will de-energize. If a zone is locked the unit will automatically begin scanning again so that all alarm conditions can be displayed. The Main display flashes when displaying zones with an alarm triggered. The Function display indicates which alarm is active on that zone. A High alarm flashes the left digit while a Low alarm flashes the right digit. Upon exiting and re-entering run mode, alarm conditions are processed and trigger delays are re-armed.

17.2 PID Control

When a zone is in PID control mode, the output power is calculated by the following equation:

$$PID = K_p e + K_i \int e dt + K_d \frac{de}{dt}$$

PID = Pulse Width % (Active Low)

K_p = Proportional Gain (Function 44)

K_i = Integral Gain (Function 45)

K_d = Derivative Gain (Function 46)

$e = (T_{setpoint} - T_{measured})$ (Multiply by -1 for cooling)

t = time in seconds (Nominal Sample time is 400ms)

Use of the auto-tune feature is recommended to determine the initial set of PID terms. If manual tuning is required Functions 44, 45 and 46 can be edited.

For certain systems a PI, PD or purely proportional control may be needed. This can be accomplished by setting Integral and/or Derivative gain to zero. Setting Integral Gain to zero sets the controller to “PD” control, setting Derivative Gain to zero sets the controller to “PI” control, and setting both to zero sets the controller to proportional control.

17.3 Autotune

The autotune function uses the relay feedback method which applies full power to the output when the process value is below the autotune setpoint and turns off the output when the process value is above the autotune setpoint (or vice versa for direct control). Several cycles are repeated and then the system parameters are computed. Autotune should be run when the current process value is near the autotune setpoint. Select an autotune setpoint that is a typical operating point. It is sometimes desirable to run autotune twice in a row. The first autotune brings the system the desired operating condition. The second autotune can then calculate a more accurate set of parameters once the system has stabilized.

Autotune must be conducted one zone at a time when using the front panel but can be triggered on any number of channels simultaneously using the Modbus commands.

17.4 Ramp & Soak

Any zone can be selected for Ramp & Soak. Each zone can configure a maximum of 20 segments independently. Each segment consists of 3 parameters: Segment Setpoint (degrees), Segment Slope (degrees/minute) and Segment Time (hours). When a segment is active, it can assume one of the following modes depending on its configurations: Idle, Ramping, Soaking, Holding. The first segment always runs in Ramping from the current process/temperature. Segment Control (Function 75) configures the number of segments in the profile and must not be zero.

The behavior of the controller after the last segment has finished running is defined in the Control Mode (Function 48). If Stop (1) is selected the output is turned off and 51 is displayed in the Function Display. If Hold (2) is selected the last Setpoint is held indefinitely and 52 is shown in the Function Display.

Ramp & Soak control can be paused at any time by entering the programming menu (Idle Mode). All outputs are turned off and all profile times are paused. When the unit returns to Run mode, all ramp & soak profiles resume. Profiles can be stopped and/or restarted by using Function 79.

18. Communication Interface

The CN616A Controller uses the Modbus/RTU interface as described in MODBUS APPLICATION PROTOCOL SPECIFICATION (V1.1b3).

The Modbus specification allows accessing to up 65535 internal 'holding' registers using register READ, register WRITE and WRITE MULTIPLE commands. Each Modbus holding register is defined as a 16-bit entity structured as BIG ENDIAN values (most significant byte always presented first).

Modbus is structured using a MASTER-SLAVE topology, in which there is one MASTER device and up to 247 slave devices. All transactions are initiated by the MASTER device. The CN616A acts as a slave device,

Modbus slave devices are individually accessed using a one byte SLAVE address. The MASTER device initiates a transaction by sending a request packet to a specific slave. The SLAVE device processes the transaction and returns either response packet indicating success or failure.

Address 0 is reserved as a 'broadcast' address, in which all slave devices will accept and process the transaction but will not send a response.

18.1 Modbus Functions

The CN616A Modbus interface supports the following Modbus FUNCTION requests.

Function Code	Mnemonic	Description
0x03	Read Holding Register	Reads one or more consecutive 16 bit holding registers
0x06	Write Single Register	Writes a specific 16 bit holding register
0x10	Write Multiple Registers	Write one or more consecutive 16 bit holding registers

18.2 Data Formats

Modbus holding registers are represented as 16-bit entities. The following encoding is used for extended data items. Note that 'byte 0' will be the first byte received/transmitted.

For data types that can be represented in 16 bit (Boolean, byte, char, int16 and uint16) a single register is used.

For data types that require 32 bits two consecutive registers are used. The lower number register will represent the most significant data. The 2nd register represents the least significant data.

18.3 Multiple Register Reads (FC03)

When reading a dual register entity the lower order register should be used as the requested 'holding register', with a request for a minimum of 2 registers. Internally the entire entity is read and data is then built into a response packet.

The access can be split into 2 consecutive single register reads. When the lower (base) register is accessed the entire 32 bit entity is read and the two most significant bytes are returned. The following single register read must specify the next consecutive register address. The two least significant bytes of the internally buffered data used in the response.

Attempts to access the two least significant bytes without first reading the two most significant bytes will result in an error response.

18.4 Multiple Register Writes (FC10)

When writing a dual register entity, the lower order register should be used as the requested 'holding register', with a request for minimum of 2 registers. The write data is internally buffered and transferred to the database entry as a 32-bit value.

The access can be split into 2 consecutive single register writes. When the lower (base) register is written the 16-bit entity is internally buffered BUT NO DATA TRANSFER IS MADE TO THE DATABASE. The following single register write must specify the next consecutive register address. The two least significant bytes of the write request are combined with the previous write data and the entire 32-bit entity is written to the database.

Attempts to write the two least significant bytes without first writing the two most significant bytes will result in an error response.

Data Type	# of Registers	Byte				Description
		0	1	2	3	
Boolean	1	--	LSB	N/A	Zero = OFF, non-zero = ON	
Byte/Char	1	--	LSB		Entity contained in LSB of register, Byte 0 ignored.	
Int16/uint16	1	MSB	LSB		Entity contained in MSB/LSB of register.	

Data Type	# of Registers	Byte				Description
		0	1	2	3	
Int32/uint32	2	MSB	B-1	B-2	LSB	Requires 2 consecutive registers, MSB transferred first
float	2	Sign+ Exp	Mantisa MSB	B-1	Mantisa LSB	IEEE formatted value contained in 2 consecutive register

19. Modbus Registers Listing

All accesses to the CN616A database information is made thru the following Modbus registers.

Data types:

R – single 16 bit register (may be Boolean, byte, char, int16 or uint16 data)

L – dual (32 bit) register (may be int32 or uint32 data)

F – IEEE Floating point value

B – Byte Array

All data is transferred using Big Endian formatting, where the most significant byte is transmitted first.

19.1 System Registers

Index		Mnemonic	Type	Access	Default	Description
0x0000	40000	Reserved				
0x0001	40001	Device Description	R	R	---	Device description
0x0002	40002	FW Version Major Minor	R	R	---	First two octets of Firmware Version
0x0003	40003	FW Version Minor Fix	R	R	---	Last two octets of Firmware Version
0x0004	40004	Reserved				
0x0005	40005	Max Zones	R	R	6/12	Max zones supported by device
0x0006	40006	Temperature Scale	R	RW	DEGREE_C	Select Fahrenheit or Celsius degree
0x0007	40007	Sensor Type	R	RW	TC	Enumerated sensor type
0x0008	40008	Sensor Subtype	R	RW	TYPE_K	Enumerated sensor sub-type
0x0009	40009	Password	R	RW	1011	Password
0x000a	40010	Modbus Address	R	RW	1	Device address on the bus.
0x000b	40011	Scan Time Second	R	RW	3	Display time per zone in seconds
0x000c	40012	Active Zone	R	RW	0xFFF	Bitmap of currently active zone
0x000d	40013	Reserved				
0x0013	40019	Factory Default	R	RW	---	Reset device to factory default
0x0015	40021	System State	R	RW	SYSTEM_IDLE	Enumerated system state
0x0016	40022	Startup State	R	RW	SYSTEM_RUN	Enumerated system state
0x0018	40024	System Alarm Type	R	RW	HI_LO_ALARM	Enumerated alarm type
0x0019	40025	System Alarm Latch	R	RW	DISABLE	Enumerated setting toggle
0x001a	40026	Password Enable	R	RW	DISABLE	Enumerated toggle setting
0x001b	40027	Decimal Point	R	RW	0	Decimal points displayed (mA/mV Only)

Table 5 – System Registers

19.2 Temperature Registers

Index		Mnemonic	Type	Access	Default	Description
0x0100	40256	Temperature Zone 1	F	R	---	Zone 1 Process Value
0x0102	40258	Temperature Zone 2	F	R	---	Zone 2 Process Value
0x0104	40260	Temperature Zone 3	F	R	---	Zone 3 Process Value
0x0106	40262	Temperature Zone 4	F	R	---	Zone 4 Process Value
0x0108	40264	Temperature Zone 5	F	R	---	Zone 5 Process Value
0x010a	40266	Temperature Zone 6	F	R	---	Zone 6 Process Value
0x010c	40268	Temperature Zone 7	F	R	---	Zone 7 Process Value
0x010e	40270	Temperature Zone 8	F	R	---	Zone 8 Process Value
0x0110	40272	Temperature Zone 9	F	R	---	Zone 9 Process Value
0x0112	40274	Temperature Zone 10	F	R	---	Zone 10 Process Value
0x0114	40276	Temperature Zone 11	F	R	---	Zone 11 Process Value
0x0116	40278	Temperature Zone 12	F	R	---	Zone 12 Process Value

19.3 Sensor Status Registers

Index		Mnemonic	Type	Access	Default	Description
0x0180	40384	Sensor Status Zone 1	R	R	---	Zone 1 Sensor status
0x0181	40385	Sensor Status Zone 2	R	R	---	Zone 2 Sensor status
0x0182	40386	Sensor Status Zone 3	R	R	---	Zone 3 Sensor status
0x0183	40387	Sensor Status Zone 4	R	R	---	Zone 4 Sensor status
0x0184	40388	Sensor Status Zone 5	R	R	---	Zone 5 Sensor status
0x0185	40389	Sensor Status Zone 6	R	R	---	Zone 6 Sensor status
0x0186	40390	Sensor Status Zone 7	R	R	---	Zone 7 Sensor status
0x0187	40391	Sensor Status Zone 8	R	R	---	Zone 8 Sensor status
0x0188	40392	Sensor Status Zone 9	R	R	---	Zone 9 Sensor status
0x0189	40393	Sensor Status Zone 10	R	R	---	Zone 10 Sensor status
0x018a	40394	Sensor Status Zone 11	R	R	---	Zone 11 Sensor status
0x018b	40395	Sensor Status Zone 12	R	R	---	Zone 12 Sensor status
0x018c	40396	Sensor Status Bitmap	R	R	---	Sensor status bitmap for all zones
0x018d	40397	Alarm Status Bitmap	R	R	---	Alarm status bitmap for all zones

Table 6 – Sensor Status Registers

19.4 Zone Registers

The zone specific registers are repeated

Zone 1 Register Base = 0x200

Zone 2 Register Base = 0x280

Zone 3 Register Base = 0x300

Zone 4 Register Base = 0x380

Zone 5 Register Base = 0x400

Zone 6 Register Base = 0x480

Zone 7 Register Base = 0x500

Zone 8 Register Base = 0x580

Zone 9 Register Base = 0x600

Zone 10 Register Base = 0x680

Zone 11 Register Base = 0x700

Zone 12 Register Base = 0x780

Index	Mnemonic	Type	Access	Default	Description
Base + 0x00	Setpoint High	F	RW	9000.0	Setpoint High for alarm
Base + 0x02	Setpoint Low	F	RW	-900.0	Setpoint Low for alarm
Base + 0x04	Alarm 1 Mode	R	RW	HI_LO_ALARM	Enumerated alarm mode
Base + 0x05	Alarm 1 Latch	R	RW	ENABLE	Enumerated setting toggle
Base + 0x06	Alarm 1 Status	R	RW	ALARM_NONE	Enumerated alarm status
Base + 0x07	Alarm 2 Mode	R	RW	ALARM_OFF	Enumerated alarm mode
Base + 0x08	Alarm 2 Latch	R	RW	ENABLE	Enumerated setting toggle
Base + 0x09	Alarm 2 Status	R	RW	ALARM_NONE	Enumerated alarm status
Base + 0x0a	Current Scale High	F	RW	20.0	High scale reading for current input
Base + 0x0c	Current Scale Low	F	RW	4.0	Low scale reading for current input
Base + 0x0e	Voltage Scale High	F	RW	1000.0	High scale reading for voltage input
Base + 0x10	Voltage Scale Low	F	RW	0.0	Low scale reading for voltage input

Table 7 – Zone Registers

Example:

Current Scale High register for Zone 7

Index = 40,000 + Base + Index = 40,000 + 0x500 + 0x0a = 41290

19.5 User Calibration

Index		Mnemonic	Type	Access	Default	Description
0x1d7c	47548	Zone 1 RTD offset	F	RW	0.0	Offset Ohm for Zone 1
0x1d7e	47550	Zone 2 RTD offset	F	RW	0.0	Offset Ohm for Zone 2
0x1d80	47552	Zone 3 RTD offset	F	RW	0.0	Offset Ohm for Zone 3
0x1d82	47554	Zone 4 RTD offset	F	RW	0.0	Offset Ohm for Zone 4
0x1d84	47556	Zone 5 RTD offset	F	RW	0.0	Offset Ohm for Zone 5
0x1d86	47558	Zone 6 RTD offset	F	RW	0.0	Offset Ohm for Zone 6
0x1d88	47560	Zone 7 RTD offset	F	RW	0.0	Offset Ohm for Zone 7
0x1d8a	47562	Zone 8 RTD offset	F	RW	0.0	Offset Ohm for Zone 8
0x1d8c	47564	Zone 9 RTD offset	F	RW	0.0	Offset Ohm for Zone 9
0x1d8e	47566	Zone 10 RTD offset	F	RW	0.0	Offset Ohm for Zone 10
0x1d90	47568	Zone 11 RTD offset	F	RW	0.0	Offset Ohm for Zone 11
0x1d92	47570	Zone 12 RTD offset	F	RW	0.0	Offset Ohm for Zone 12

Table 8 – User Calibration

19.6 PID Registers

The zone specific registers are repeated

Zone 1 Register Base = 0x800

Zone 2 Register Base = 0x880

Zone 3 Register Base = 0x900

Zone 4 Register Base = 0x980

Zone 5 Register Base = 0xA00

Zone 6 Register Base = 0xA80

Index	Mnemonic	Type	Access	Default	Description
Base + 0x00	Start Profile	R	RW	DISABLE	Enumerated toggle setting
Base + 0x01	Control Action	R	RW	ACTION REVERSE	Enumerated Output action setting
Base + 0x02	Control Method	R	RW	ON_OFF CONTROL	Enumerated Control Method setting
Base + 0x03	Number of Segments	R	RW	1	Ramp & Soak profile number of segments [0..19]
Base + 0x04	Current Segment Index	R	R	0	Active segment index [0..19]
Base + 0x05	Current Segment State	R	R	SEGMENT IDLE	Enumerated segment state
Base + 0x06	Deadband	F	RW	0.0	Hysteresis value in process units
Base + 0x08	Absolute Setpoint	F	RW	0.0	Dynamic control setpoint in Run mode or Manual output value in Idle mode.
Base + 0x0A	Control Setpoint	F	RW	0.0	Dynamic control setpoint in Run mode or Manual output value in Idle mode.
Base + 0x0C	Proportional Gain	F	RW	1.0	PID control proportional gain
Base + 0x0E	Integral Gain	F	RW	0.0	PID control integral gain
Base + 0x10	Derivative Gain	F	RW	0.0	PID control derivative gain
Base + 0x12	Control Output	F	RW	0.0	Output power [0..100%]
Base + 0x14	Cycle Time	F	RW	5.0	PWM cycle time in seconds (applies to all zones)
Base + 0x16	Autotune Control	R	RW	DISABLE	Enumerated Toggle setting
Base + 0x17	Loop Status	R	R	STATUS STOPPED	Enumerated Loop status setting
Base + 0x18	Autotune Setpoint	F	RW	0.0	Setpoint for which autotune is performed at in process units
Base + 0x1a	Control Mode	R	RW	STANDARD CONTROL	Enumerated Control mode setting
Base + 0x1b	Ramp/Soak Remaining	F	R	0.0	Remaining temperature toward setpoint if the segment is ramping. Or remaining soak time in seconds if the segment is soaking.

Tip: Manual Output Control

Manual control of the PWM output is sometimes desirable when testing the output actuator functionality or wiring harness. This can be supported using Modbus commands. All sensors must be installed correctly since an open circuit will disable the outputs. To check that all sensors are working confirm that no zones show Function code 88 during Run mode. To use manual control, enter the programming menu then directly write the PWM percentage to the Control Output register. A zero value corresponds to output fully off while 100.0% value corresponds to output fully on. To resume automatic control, put the system to Run mode. The Control Output Register settings cannot be saved.

19.7 Profile Registers

Zone 1 Profile Base = 0x1000
 Zone 2 Profile Base = 0x1100
 Zone 3 Profile Base = 0x1200
 Zone 4 Profile Base = 0x1300
 Zone 5 Profile Base = 0x1400
 Zone 6 Profile Base = 0x1500

Segment 1 Offset = 0x00
 Segment 2 Offset = 0x01
 ...
 Segment 19 Offset = 0x12
 Segment 20 Offset = 0x13

Index	Mnemonic	Type	Access	Default	Description
Base + 6 * Offset + 0x00	Segment Setpoint	F	RW	0.0	Segment target temperature
Base + 6 * Offset + 0x02	Segment Slope	F	RW	10.0	Segment temperature rate of change per minute
Base + 6 * Offset + 0x04	Segment Time	F	RW	1.0	Segment soak time in hours

Example:

Zone 2, Segment 5 Setpoint register address = $(0x1100 + 6 * 0x04 + 0x00) = 0x1118$

Zone 2, Segment 5 Slope register address = $(0x1100 + 6 * 0x04 + 0x02) = 0x111a$

Zone 2, Segment 5 Time register address = $(0x1100 + 6 * 0x04 + 0x04) = 0x111c$

20. Modbus Register Enumerated Values

The following define the Enumerated values

20.1 Sensor Type

Sensor Type		
0	THERMOCOUPLE	Thermocouple input
1	RTD2 Wire	Resistance Temperature Detector input 2 Wire
2	RTD3 Wire*	Resistance Temperature Detector input 3 Wire
3	CURRENT	Process Current input
4	VOLTAGE	Process Voltage input

*Not Supported for CN616A

20.2 RTD Type

RTD Type		
0	PT_100	Platinum Pt100 RTD
1	NI_120	Nickel Ni120 RTD
2	CU_10	Copper Cu10 RTD

20.3 Thermocouple Type

Thermocouple Type		
0	TYPE_B	Thermocouple B type
1	TYPE_C	Thermocouple C type
2	TYPE_E	Thermocouple E type
3	TYPE_J	Thermocouple J type
4	TYPE_K	Thermocouple K type
5	TYPE_R	Thermocouple R type
6	TYPE_S	Thermocouple S type
7	TYPE_T	Thermocouple T type
8	TYPE_N	Thermocouple N type

20.4 Sensor Status

Sensor Status		
0	VALID	Sensor is normal
1	OUT_OF_RANGE_LOW	Sensor Reading is below valid range
2	OUT_OF_RANGE_HIGH	Sensor Reading is above valid range
3	SHORT_CIRCUIT	Sensor is short circuit
4	OPEN_CIRCUIT	Sensor is open circuit

20.5 Decimal point

Decimal Point		
0	DECIMAL_POINT_ZERO	Zero decimal point.
1	DECIMAL_POINT_ONE	One decimal point.
2	DECIMAL_POINT_TWO	Two decimal point.
3	DECIMAL_POINT_THREE	Three decimal point.

20.6 System State

System State		
0	RUN_MODE	Alarms are active. Controls are active.
1	IDLE_MODE	Alarms are reset. Controls are off.

20.7 Process Unit

Process Unit		
0	DEGREE_C	Process unit is Celsius
1	DEGREE_F	Process unit is Fahrenheit

20.8 Alarm Type

Alarm Type		
0	ALARM_HIGH	Alarm activated when PV > Alarm High SP
1	ALARM_LOW	Alarm activated when PV < Alarm Low SP
2	HI_LOW_ALARM	Alarm activated when Alarm Low SP < PV < Alarm High SP
3	ALARM_OFF	Alarm is disabled
4	ALARM_SPLIT_A_B	Alarm 1 activates Alarm relay A, alarm 2 activates Alarm relay B

20.9 Alarm Status

Alarm Status		
0	ALARM_NONE	No alarm condition is triggered
1	ALARM_HIGH	Alarm high condition is triggered
2	ALARM_LOW	Alarm low condition is triggered
3	ALARM_HIGH_LOW	Alarm high low condition is triggered

20.10 Setting Toggle

Toggle		
0	DISABLE	Setting is disabled.
1	ENABLE	Setting is enabled.

20.11 Output Action

Output Action		
0	ACTION_REVERSE	Zone is configured for Heating
1	ACTION_DIRECT	Zone is configured for Cooling

20.12 Control Mode

Control Mode		
0	STANDARD_CONTROL	Zone is configured for fixed setpoint control
1	RAMP_SOAK_1	Zone is configured for Ramp & Soak which terminates when
2	RAMP_SOAK_2	Zone is configured for Ramp & Soak which holds when finished

20.13 Control Method

PID Enable		
0	ON_OFF_CONTROL	Zone uses On/Off control.
1	PID_CONTROL	Zone uses PID control.

20.14 Autotune Control

Autotune Control		
0	DISABLE	Write to Stop autotune in progress, or Read to confirm autotune is not running.
1	ENABLE	Write to Start autotune, or Read to confirm autotune is running.

20.15 Segment State

Segment State		
0	IDLE	Segment is idle. Output is off.
1	RAMPING	Segment is ramping. Output is active.
2	SOAKING	Segment is soaking. Output is active.
3	HOLDING	Segment is holding indefinitely at setpoint. Output is active.

20.16 Loop Status

Loop Status		
0	STOPPED	Control is not running. Output is off.
1	IDLE	Control is idle. Output is off.
2	STANDARD	Control is running at fixed setpoint. Output is active.
3	RAMP_SOAK	Control is running with Ramp/Soak. Output is active.
4	AUTOTUNE_STAGE_1	Autotune stage 1 is running. Output is active.
5	AUTOTUNE_STAGE_2	Autotune stage 2 is running. Output is active.
6	AUTOTUNE_STAGE_3	Autotune stage 3 is running. Output is active.

21. Specifications

21.1 General

Display	4-digit, 7-segment LED; red, 14 mm (0.55")
Dimensions	95 x 95 x 135mm
Panel Cutout	¼ DIN 92 x 92mm
Environmental Conditions	-20 to +70°C (32–122°F), 90% RH non-condensing (Operating) -40 to +85°C (32–122°F), 90% RH non-condensing (Storage) Pollution Degree 2 Altitude of up to 2000 meters Indoor use
External Fuse Required	Time-Delay, UL 248-14 listed: <ul style="list-style-type: none">• 25 mA/250 V• 300 mA/250 V (Low-Voltage Option) Time-Lag, IEC 127-3 recognized: <ul style="list-style-type: none">• 25 mA/250 V• 300 mA/250 V (Low-Voltage Option)
Line Voltage/Power	<ul style="list-style-type: none">• 120/240 Vac, 50/60Hz, 3W
Low-Voltage/Power Option	External power source must meet Safety Agency Approvals. <ul style="list-style-type: none">• 9–36 Vdc, 3 W
Protection	NEMA-1/Type 1 front bezel
Weight	725 g
Communications	Selectable RS232 / RS485 Modbus RTU

21.2 Alarm Relays

AC Power Option	2x SPDT, 240Vac, 5A Load 5A External Fuse Required
DC Power Option	2x SPDT, 36Vdc, 3A Load 3A External Fuse Required

21.3 Input Accuracy

Measurement Ranges and Accuracies based on Operating Temperature			Operating Temperature		
Input Type	Description	Range	Accuracy (25°C)	Accuracy (0 to 50°C)	Accuracy (-20 to 70°C)
Process	Process Voltage	0 to 1000 mV	± 1 mV	± 1 mV	± 1 mV
	Process Current	0 to 24.00 mA	± 10 µA	± 10 µA	± 10 µA
J Type T/C	J Iron-Constantan	-150 to 0°C	± 1.0°C	± 2.0°C	± 6.0°C
		0 to 1200°C	±1.0°C	± 1.0°C	± 2.0°C
K Type T/C	CHROMEGLA™ - ALOMEGA™	-150 to 0°C	± 1.0°C	± 2.0°C	± 5.0°C
		0 to -1372°C	± 1.0°C	± 1.0°C	± 2.0°C
T Type T/C	Copper-Constantan	-150 to 0°C	± 1.0°C	± 2.0°C	± 7.0°C
		0 to 400°C	± 1.0°C	± 1.0°C	± 2.0°C
E Type T/C	CHROMEGLA™ -Constantan	-150 to 0°C	± 1.0°C	± 2.0°C	± 5.0°C
		0 to 1000°C	± 1.0°C	± 1.0°C	± 2.0°C
R Type T/C	Pt/13%Rh-Pt	-50 to 0°C	± 1.0°C	± 2.0°C	± 6.0°C
		0 to 1788°C	± 1.0°C	± 1.0°C	± 2.0°C
S Type T/C	Pt/10%Rh-Pt	-50 to 0°C	± 1.0°C	± 2.0°C	± 5.0°C
		0 to 1768°C	± 1.0°C	± 1.0°C	± 2.0°C
B Type T/C	30%Rh-Pt/6%Rh-Pt	150 to 700°C	± 1.0°C	± 2.0°C	± 3.0°C
		700 to 1820°C	± 1.0°C	± 1.0°C	± 1.0°C
C Type T/C	5%Re-W/26%Re-W	0 to 2320°C	± 1.0°C	± 1.0°C	± 3.0°C
N Type T/C	Nicrosil-Nisil	-150 to 0°C	± 1.0°C	± 2.0°C	± 5.0°C
		0 to 1300°C	± 1.0°C	± 1.0°C	± 2.0°C
RTD 2 Wire	Pt, 0.00385, 100 Ω	-200 to 850°C	± 1.0°C	± 1.0°C	± 1.0°C
RTD 2 Wire	Cu, 0.00427, 10 Ω	-200 to 260°C	± 1.0°C	± 1.0°C	± 1.0°C
RTD 2 Wire	Ni, 0.00672, 120 Ω	-80 to 260°C	± 1.0°C	± 1.0°C	± 1.0°C

Table 16 - Input Accuracy

* Absolute Maximum 3.3V (Process Voltage) or 30mA (Process Current).

22. Approvals Information



This product conforms to the EMC: 2014/30/EU (EMC Directive).

Electrical Safety:

This product conforms to the LVD:2014/35/EU (Low Voltage Directive)

UL / CSA:

UL 61010-1 / CSA 222.2 NO 61010-1-12

Safety Requirements for Electrical Equipment for Measurement, Control, and Laboratory Use, Part 1.

UL61010-2-201 / CS 22.2 NO. 61010-2-201:14

Standard for Safety Requirements for Electrical Equipment for Measurement, Control, and Laboratory Use. Part 2-201: Particular requirements for control equipment.

UL File Number: E209855



Correct Disposal of This Product (Waste Electrical & Electronic Equipment)

In conformity with Directive 2012/19/EU-WEEE, this marking shown on the product or its literature, indicates that it should not be disposed of, with other household wastes at the end of its working life. To prevent possible harm to the environment or human health from uncontrolled waste disposal, please separate this product from other types of wastes and recycle it responsibly to promote the sustainable reuse of material resources.

Household users should contact either the retailer where they purchased this product, or their local government office, for details of where and how they can return this item for environmentally safe recycling.

Business users should contact their supplier and check the terms and conditions of the purchase contract. This product should not be mixed with other commercial wastes for disposal

WARRANTY/DISCLAIMER

OMEGA ENGINEERING, INC. warrants this unit to be free of defects in materials and workmanship for a period of **25 months** from date of purchase. OMEGA's WARRANTY adds an additional one (1) month grace period to the normal **two (2) year product warranty** to cover handling and shipping time. This ensures that OMEGA's customers receive maximum coverage on each product.

If the unit malfunctions, it must be returned to the factory for evaluation. OMEGA's Customer Service Department will issue an Authorized Return (AR) number immediately upon phone or written request. Upon examination by OMEGA, if the unit is found to be defective, it will be repaired or replaced at no charge. OMEGA's WARRANTY does not apply to defects resulting from any action of the purchaser, including but not limited to mishandling, improper interfacing, operation outside of design limits, improper repair, or unauthorized modification. This WARRANTY is VOID if the unit shows evidence of having been tampered with or shows evidence of having been damaged as a result of excessive corrosion; or current, heat, moisture or vibration; improper specification; misapplication; misuse or other operating conditions outside of OMEGA's control. Components in which wear is not warranted, include but are not limited to contact points, fuses, and triacs.

OMEGA is pleased to offer suggestions on the use of its various products. However, OMEGA neither assumes responsibility for any omissions or errors nor assumes liability for any damages that result from the use of its products in accordance with information provided by OMEGA, either verbal or written. OMEGA warrants only that the parts manufactured by the company will be as specified and free of defects. OMEGA MAKES NO OTHER WARRANTIES OR REPRESENTATIONS OF ANY KIND WHATSOEVER, EXPRESSED OR IMPLIED, EXCEPT THAT OF TITLE, AND ALL IMPLIED WARRANTIES INCLUDING ANY WARRANTY OF MERCHANTABILITY AND FITNESS FOR A PARTICULAR PURPOSE ARE HEREBY DISCLAIMED. LIMITATION OF LIABILITY: The remedies of purchaser set forth herein are exclusive, and the total liability of OMEGA with respect to this order, whether based on contract, warranty, negligence, indemnification, strict liability or otherwise, shall not exceed the purchase price of the component upon which liability is based. In no event shall OMEGA be liable for consequential, incidental or special damages.

CONDITIONS: Equipment sold by OMEGA is not intended to be used, nor shall it be used: (1) as a "Basic Component" under 10 CFR 21 (NRC), used in or with any nuclear installation or activity; or (2) in medical applications or used on humans. Should any Product(s) be used in or with any nuclear installation or activity, medical application, used on humans, or misused in any way, OMEGA assumes no responsibility as set forth in our basic WARRANTY/DISCLAIMER language, and, additionally, purchaser will indemnify OMEGA and hold OMEGA harmless from any liability or damage whatsoever arising out of the use of the Product(s) in such a manner.

RETURN REQUESTS/INQUIRIES

Direct all warranty and repair requests/inquiries to the OMEGA Customer Service Department. BEFORE RETURNING ANY PRODUCT(S) TO OMEGA, PURCHASER MUST OBTAIN AN AUTHORIZED RETURN (AR) NUMBER FROM OMEGA'S CUSTOMER SERVICE DEPARTMENT (IN ORDER TO AVOID PROCESSING DELAYS). The assigned AR number should then be marked on the outside of the return package and on any correspondence.

The purchaser is responsible for shipping charges, freight, insurance and proper packaging to prevent breakage in transit.

FOR **WARRANTY** RETURNS, please have the following information available BEFORE contacting OMEGA:

1. Purchase Order number under which the product was PURCHASED,
2. Model and serial number of the product under warranty, and
3. Repair instructions and/or specific problems relative to the product.

FOR **NON-WARRANTY** REPAIRS, consult OMEGA for current repair charges. Have the following information available BEFORE contacting OMEGA:

1. Purchase Order number to cover the COST of the repair,
2. Model and serial number of the product, and
3. Repair instructions and/or specific problems relative to the product.

OMEGA's policy is to make running changes, not model changes, whenever an improvement is possible. This affords our customers the latest in technology and engineering.

OMEGA is a trademark of OMEGA ENGINEERING, INC.

© Copyright 2018 OMEGA ENGINEERING, INC. All rights reserved. This document may not be copied, photocopied, reproduced, translated, or reduced to any electronic medium or machine-readable form, in whole or in part, without the prior written consent of OMEGA ENGINEERING, INC.

Where Do I Find Everything I Need for Process Measurement and Control? **OMEGA...Of Course!** *Shop online at omega.com*

TEMPERATURE

- ☑ Thermocouple, RTD & Thermistor Probes, Connectors, Panels & Assemblies
- ☑ Wire: Thermocouple, RTD & Thermistor
- ☑ Calibrators & Ice Point References
- ☑ Recorders, Controllers & Process Monitors
- ☑ Infrared Pyrometers

PRESSURE, STRAIN AND FORCE

- ☑ Transducers & Strain Gages
- ☑ Load Cells & Pressure Gages
- ☑ Displacement Transducers
- ☑ Instrumentation & Accessories

FLOW/LEVEL

- ☑ Rotameters, Gas Mass Flowmeters & Flow Computers
- ☑ Air Velocity Indicators
- ☑ Turbine/Paddlewheel Systems
- ☑ Totalizers & Batch Controllers

pH/CONDUCTIVITY

- ☑ pH Electrodes, Testers & Accessories
- ☑ Benchtop/Laboratory Meters
- ☑ Controllers, Calibrators, Simulators & Pumps
- ☑ Industrial pH & Conductivity Equipment

DATA ACQUISITION

- ☑ Communications-Based Acquisition Systems
- ☑ Data Logging Systems
- ☑ Wireless Sensors, Transmitters, & Receivers
- ☑ Signal Conditioners
- ☑ Data Acquisition Software

HEATERS

- ☑ Heating Cable
- ☑ Cartridge & Strip Heaters
- ☑ Immersion & Band Heaters
- ☑ Flexible Heaters
- ☑ Laboratory Heaters

ENVIRONMENTAL MONITORING AND CONTROL

- ☑ Metering & Control Instrumentation
- ☑ Refractometers
- ☑ Pumps & Tubing
- ☑ Air, Soil & Water Monitors
- ☑ Industrial Water & Wastewater Treatment
- ☑ pH, Conductivity & Dissolved Oxygen Instruments