

## Snap Action Switch

V

### General Purpose Snap Action Switch

- Industry standard design with 10/15 A ratings
- Long service life of 50,000,000 operations minimum (mechanical)



## Ordering Information

### ■ THERMOSET MATERIAL







(●: standard. ○: available on request)

Remarks	Ratings	Common Terminal position	Contact Gap		Terminal Shape (see note)					OF max.					Part number
			1 mm	0.5 mm	A	C2	C	B	E	15	25	100	200	400	
Mounted with 2.9 mm dia. screws. The switch unit is housed in a thermoset case, and has high versatility in applications.	15 A, 250 V	Bottom	○	●	●	●	○	○	○	—	—	○	●	○	V-15
	10 A, 250 V	Bottom	○	●	●	●	○	○	○	—	—	●	●	—	V-10

Note: 1. A: Solder/quick connect terminal (#187)  
 C2: Quick connect terminal (#187)  
 C: Quick connect terminal (#250)  
 B: Screw terminal  
 E: Short solder terminal

(This section continues on next page)

Ordering Information - continued from previous page

Actuator	Common Terminal Position	Contact Form	Connect Terminal	Part Number		
				Rated Current		
				15 A	10 A	
				200 grams	200 grams	100 grams
	Bottom	SPDT	A	V-15G-1A5-K	V-10G-1A5-K	V-10G-1A4-K
			C2	V-15G-1C25-K	V-10G-1C25-K	V-10G-1C24-K
			C	V-15G-1C5-K	—	—
			B	V-15G-1B5-K	V-10G-1B5-K	V-10G-1B4-K
			E	V-15G-1E5-K	—	V-10G-1E4-K
		SPST-NC	A	V-15G-2A5-K	V-10G-2A5-K	V-10G-2A4-K
			C2	V-15G-2C25-K	V-10G-2C25-K	V-10G-2C24-K
			C	V-15G-2C5-K	—	—
		SPST-NO	A	V-15G-3A5-K	V-10G-3A5-K	V-10G-3A4-K
	C2		V-15G-3C25-K	V-10G-3C25-K	V-10G-3C24-K	
	C		V-15G-3C5-K	—	—	
	Side	SPDT	A	V-15G-4A5-K	V-10G-4A5-K	V-10G-4A4-K
C2			V-15G-4C25-K	V-10G-4C25-K	V-10G-4C24-K	
C			V-15G-4C5-K	—	—	
	Bottom	SPDT	A	—	V-10G1-1A5-K	V-10G1-1A4-K
			C2	V-15G1-1C25-K	V-10G1-1C25-K	V-10G1-1C24-K
			B	—	V-10G1-1B5-K	V-10G1-1B4-K
			E	V-15G1-1E5-K	V-10G1-1E5-K	V-10G1-1E4-K
			C	V-15G1-1C5-K	—	—
	SPST-NC	A	V-15G1-2A5-K	V-10G1-2A5-K	V-10G1-2A4-K	
		C2	V-15G1-2C25-K	V-10G1-2C25-K	V-10G1-2C24-K	
		C	V-15G1-2C5-K	—	—	
	SPST-NO	A	V-15G1-3A5-K	V-10G1-3A5-K	V-10G1-3A4-K	
		C2	V-15G1-3C25-K	V-10G1-3C25-K	V-10G1-3C24-K	
		C	V-15G1-3C5-K	—	—	
		Bottom	SPDT	A	V-15G2-1A5-K	V-10G2-1A5-K
C2				V-15G2-1C25-K	V-10G2-1C25-K	V-10G2-1C24-K
B				—	V-10G2-1B5-K	V-10G2-1B4-K
E				V-15G2-1E5-K	V-10G2-1E5-K	—
C				V-15G2-1C5-K	—	—
SPST-NC		A	V-15G2-2A5-K	V-10G2-2A5-K	V-10G2-2A4-K	
		C2	V-15G2-2C25-K	V-10G2-2C25-K	V-10G2-2C24-K	
		C	V-15G2-2C5-K	—	—	
SPST-NO		A	V-15G2-3A5-K	V-10G2-3A5-K	V-10G2-3A4-K	
		C2	V-15G2-3C25-K	V-10G2-3C25-K	V-10G2-3C24-K	
		C	V-15G2-3C5-K	—	—	
		Bottom	SPDT	A	V-15G3-1A5-K	V-10G3-1A5-K
	C2			V-15G3-1C25-K	V-10G3-1C25-K	V-10G3-1C24-K
	B			V-15G3-1B5-K	V-10G3-1B5-K	V-10G3-1B4-K
	E			—	V-10G3-1E5-K	V-10G3-1E4-K
	C			V-15G3-1C5-K	—	—
	SPST-NC	A	V-15G3-2A5-K	V-10G3-2A5-K	V-10G3-2A4-K	
		C2	V-15G3-2C25-K	V-10G3-2C25-K	V-10G3-2C24-K	
		C	V-15G3-2C5-K	—	—	
	SPST-NO	A	V-15G3-3A5-K	V-10G3-3A5-K	V-10G3-3A4-K	
		C2	V-15G3-3C25-K	V-10G3-3C25-K	V-10G3-3C24-K	
		C	V-15G3-3C5-K	—	—	
		Bottom	SPDT	A	V-15G4-1A5-K	V-10G4-1A5-K
C2				V-15G4-1C25-K	V-10G4-1C25-K	V-10G4-1C24-K
B				—	V-10G4-1B5-K	V-10G4-1B4-K
E				—	V-10G4-1E5-K	V-10G4-1E4-K
C				V-15G4-1C5-K	—	—
SPST-NC		A	V-15G4-2A5-K	V-10G4-2A5-K	V-10G4-2A4-K	
		C2	V-15G4-2C25-K	V-10G4-2C25-K	V-10G4-2C24-K	
		C	V-15G4-2C5-K	—	—	
SPST-NO		A	V-15G4-3A5-K	V-10G4-3A5-K	V-10G4-3A4-K	
		C2	V-15G4-3C25-K	V-10G4-3C25-K	V-10G4-3C24-K	
		C	V-15G4-3C5-K	—	—	
		Bottom	SPDT	A	V-15G5-1A5-K	V-10G5-1A5-K
	C2			V-15G5-1C25-K	V-10G5-1C25-K	V-10G5-1C24-K
	B			V-15G5-1B5-K	V-10G5-1B5-K	V-10G5-1B4-K
	E			—	V-10G5-1E5-K	V-10G5-1E4-K
	C			V-15G5-1C5-K	—	—
	SPST-NC	A	V-15G5-2A5-K	V-10G5-2A5-K	V-10G5-2A4-K	
		C2	V-15G5-2C25-K	V-10G5-2C25-K	V-10G5-2C24-K	
		C	V-15G5-2C5-K	—	—	
	SPST-NO	A	V-15G5-3A5-K	V-10G5-3A5-K	V-10G5-3A4-K	
		C2	V-15G5-3C25-K	V-10G5-3C25-K	V-10G5-3C24-K	
		C	V-15G5-3C5-K	—	—	
		Bottom	SPDT	A	V-15G6-1A5-K	V-10G6-1A5-K
C2				V-15G6-1C25-K	—	V-10G6-1C24-K
B				V-15G6-1B5-K	V-10G6-1B5-K	V-10G6-1B4-K
E				V-15G6-1E5-K	V-10G6-1E5-K	V-10G6-1E4-K
C				V-15G6-1C5-K	—	—
SPST-NC		A	V-15G6-2A5-K	V-10G6-2A5-K	V-10G6-2A4-K	
		C2	V-15G6-2C25-K	V-10G6-2C25-K	V-10G6-2C24-K	
		C	V-15G6-2C5-K	—	—	
SPST-NO		A	V-15G6-3A5-K	V-10G6-3A5-K	V-10G6-3A4-K	
		C2	V-15G6-3C25-K	V-10G6-3C25-K	V-10G6-3C24-K	
		C	V-15G6-3C5-K	—	—	

Note: 1. For SPST-NC and SPST-NO with levers consult Omron.  
 2. An insulation barrier is available upon request for thermoplastic types.

## Specifications

### ■ CHARACTERISTICS

		V-15	V-10
Operating speed		0.1 mm to 1 m/second (0.004 to 39.4 in/second) at pin plunger	
Operating frequency	Mechanical	600 operations per minute	
	Electrical	60 operations per minute	
Contact resistance		15 mΩ max. (initial)	30 mΩ max. (initial)
Insulation resistance		100 MΩ min. at 500 VDC	
Dielectric strength (VAC)		1,000 VAC, between non-continuous terminals 1,500 VAC, between each terminal and ground	
Vibration (see note 2)	Malfunction durability	10 to 55 Hz, 1.5 mm double amplitude	
Shock (see note 2)	Mechanical durability	1,000 m/s <sup>2</sup> min. (approx. 100 g)	
	Malfunction durability	300 m/s <sup>2</sup> min. (approx. 30 g)	200 m/s <sup>2</sup> min. (approx. 20 g)
Ambient temperature	Operating	-25° to 80°C	
Humidity	Operating	85% RH max.	
Service life	Mechanical	50,000,000 operations min.	
	Electrical	100,000 operations min.	300,000 operations min.
Weight		Approx. 6.2 g (pin plunger type)	

- Note: 1. Data shown are of initial value.  
2. The values indicated here are of the pin plunger type.

### ■ OPERATING CHARACTERISTICS

Characteristics	Part number					
	V-15G-1□5-K V-10G-1□5-K	V-10G-1□4-K	V-15G1-1□5-K V-10G1-1□5-K	V-10G1-1□4-K	V-15G2-1□5-K	V-10G2-1□4-K
OF max.	200 g	100 g	200 g	100 g	125 g	60 g
RF min.	50 g	20 g	50 g	15 g	14 g	6 g
PT max.	1.2 mm (0.05 in)		1.5 mm (0.06 in)		3.3 mm (0.13 in)	
OT min.	1.3 mm (0.05 in)		1.0 mm (0.04 in)		2.3 mm (0.09 in)	
MD max.	0.3 mm (0.01 in)		0.5 mm (0.02 in)		0.8 mm (0.03 in)	
OP	14.7±0.4 mm (0.58±0.02 in)		15.2±0.5 mm (0.60±0.02 in)		15.2 <sup>+2.6</sup> <sub>-3.2</sub> mm (0.60 <sup>+0.10</sup> <sub>-0.13</sub> in)	15.2±1.2 mm (0.60±0.05 in)

Characteristics	Part number					
	V-15G3-1□5-K V-10G3-1□5-K	V-10G3-1□4-K	V-15G4-1□5-K V-10G4-1□5-K	V-10G4-1□4-K	V-15G5-1□5-K	V-10G5-1□4-K
OF max.	70 g	35 g	125 g	60 g	240 g	120 g
RF min.	6 g	—	14 g	6 g	50 g	15 g
PT max.	9.0 mm (0.35 in)	7.6 mm (0.30 in)	3.3 mm (0.13 in)		1.5 mm (0.06 in)	
OT min.	3.0 mm (0.12 in)	3.2 mm (0.13 in)	2.3 mm (0.09 in)		1.0 mm (0.04 in)	
MD max.	2.0 mm (0.08 in)		0.8 mm (0.03 in)		0.5 mm (0.02 in)	
OP	15.2±2.6 mm (0.60±0.10 in)		18.7±1.2 mm (0.74±0.05 in)		20.7±0.6 mm (0.81±0.02 in)	

Characteristics	Part number	
	V-15G6-1□5-K V-10G6-1□5-K	V-10G6-1□4-K
OF max.	125 g	60 g
RF min.	14 g	6 g
PT max.	3.3 mm (0.13 in)	
OT min.	2.3 mm (0.09 in)	
MD max.	0.8 mm (0.03 in)	
OP	20.7±1.6 mm (0.81±0.06 in)	

■ OPERATING CHARACTERISTICS - V SERIES ACCESSORIES

Part number	VAL	VAL2	VAV	VAV2	VAM	VAM-1
Switch	V-15G-1A5-K					
OF max.	230 g		35 g	75 g	200 g	300 g
RF min.	50 g		4 g	9 g	30 g	40 g
OT max.	0.8 mm (0.03 in)		3.6 mm (0.14 in)	1.5 mm (0.06 in)	7 mm (0.28 in)	5 mm (0.20 in)
MD min.	0.4 mm (0.02 in)		4.7 mm (0.19 in)	1.2 mm (0.05 in)	7 mm (0.28 in)	6 mm (0.24 in)
FP max.	17 mm (0.67 in)	22.6 mm (0.89 in)	—	—	45 mm (1.78 in)	47 mm (1.85 in)
OP	14.9±0.5 mm (0.59±0.02 in)	20.5±0.5 mm (0.81±0.02 in)	Approx. 10.6 mm (0.42 in)	18.6±1.6 mm (0.73±0.06 in)	20±9 mm (0.79±0.35 in)	30±5 mm (1.18±0.20 in)

■ RATINGS

Type	Rated voltage	Non-inductive load (A)				Inductive load (A)				Inrush current Non-inductive & Inductive NC/NO
		Resistive load		Lamp load		Inductive load		Motor load		
		NC	NO	NC	NO	NC	NO	NC	NO	
15 A	250 VAC	15	15	2	2	10	10	3	3	36 A max.
	125 VDC	0.1	0.1	—	—	—	—	—	—	
10 A	250 VAC	10	10	1.5	1.5	6	6	2	2	24 A max.
	125 VDC	0.1	0.1	—	—	—	—	—	—	

- Note: 1. Inductive load has a power factor of 0.4 min. (AC) and a time constant of 7 milliseconds max. (DC).  
 2. Lamp load has an inrush current of 10 times the steady-state current, while motor load has an inrush current of 6 times the steady-state current.

■ CONTACT FORM

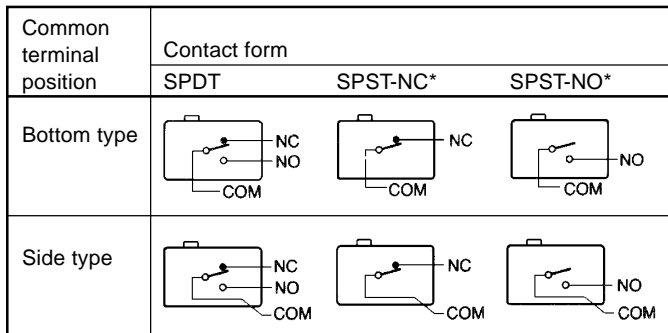

\* The SPST-NC and SPST-NO contact form types listed in the ordering information tables are for Pin Plunger models only. For information concerning lever models consult Omron.

Application load range

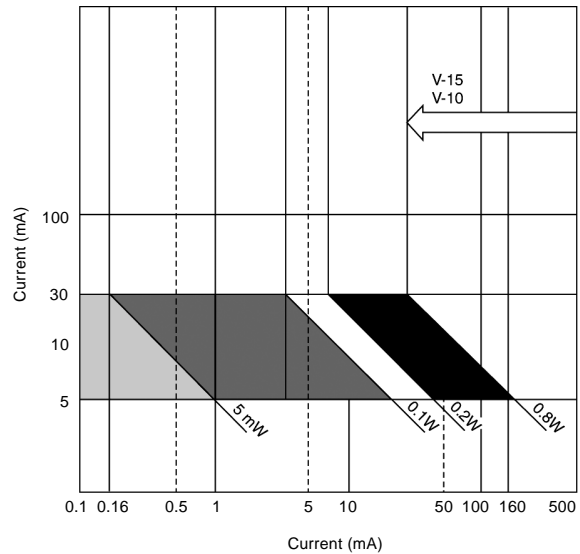

## ■ APPROVALS

UL (File No. E41515), CSA (File No. LR21642) IEC 1058-1, EN conforms 61058-1

OF max.	Thermoset material	
	V-15	V-10
100 g	UL CSA	UL CSA
200 g	UL CSA	UL CSA
400 g	UL CSA	— —

- Note: 1. The rated values approved by each of the safety standards (e.g. UL, CSA) may be different from the performance characteristics individually defined in this catalog.
2. Models approved by DEMKO, NEMKO, BEAB and SETI are also available. Consult OMRON for detailed information.

## Engineering Data

### Mechanical service life V-15, V-10

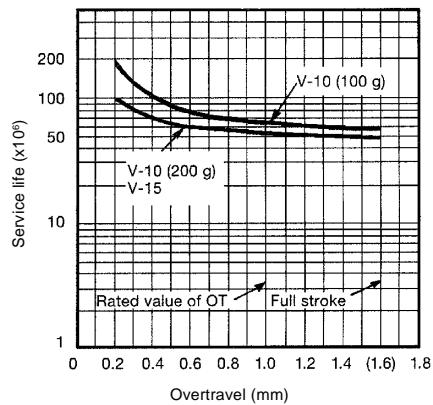

### Electrical service life V-15

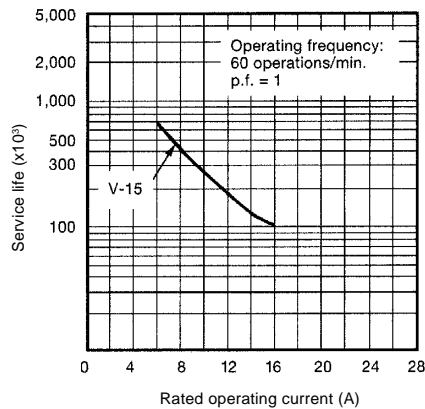

### Electrical service life V-10

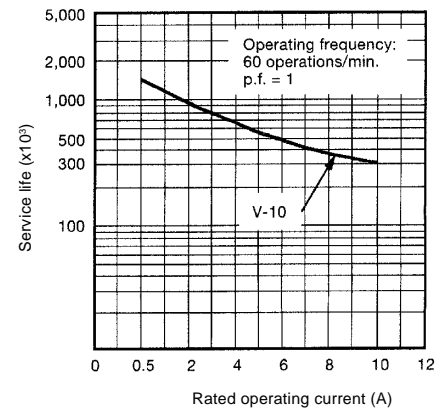

## Dimensions

Unit: mm (inch)

The following figures show the models having quick connect terminals in the #250 series at the bottom of the case. For other terminals, please refer to "Terminals."

Note: Unless otherwise specified, a tolerance of  $\pm 0.4$  mm applies to all dimensions.

### ■ PIN PLUNGER

V-15G-1□5-K

V-10G-1□5-K

V-10G-1□4-K

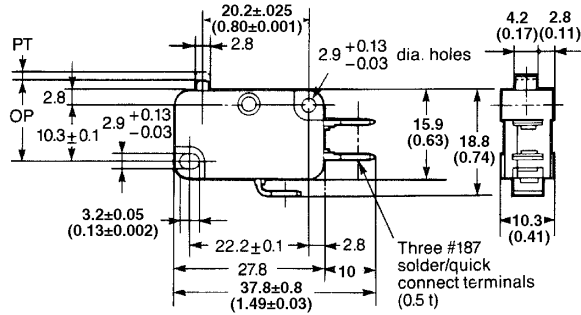

### ■ SHORT HINGE LEVER

V-15G1-1□5-K

V-10G1-1□5-K

V-10G1-1□4-K

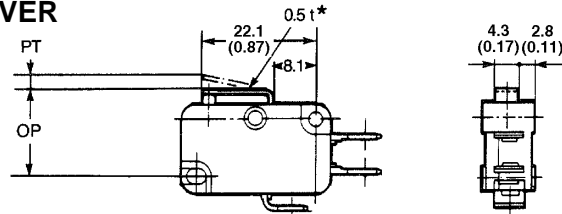

\*Stainless steel lever

### ■ HINGE LEVER

V-15G2-1□5-K

V-10G2-1□5-K

V-10G2-1□4-K

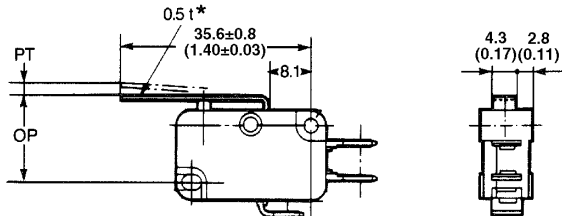

\*Stainless steel lever

### ■ LONG HINGE LEVER

V-15G3-1□5-K

V-10G3-1□5-K

V-10G3-1□4-K

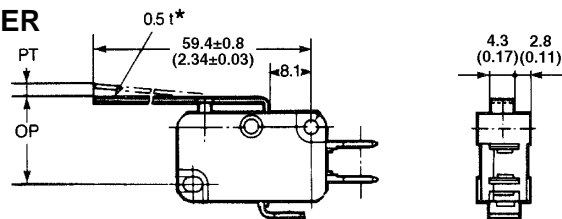

\*Stainless steel lever

### ■ SIMULATED ROLLER LEVER

V-15G4-1□5-K

V-10G4-1□5-K

V-10G4-1□4-K

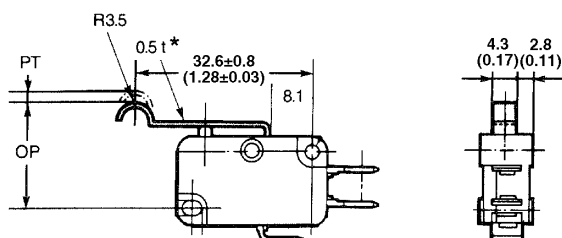

\*Stainless steel lever

■ SHORT HINGE ROLLER LEVER

- V-15G5-1□5-K
- V-10G5-1□5-K
- V-10G5-1□4-K

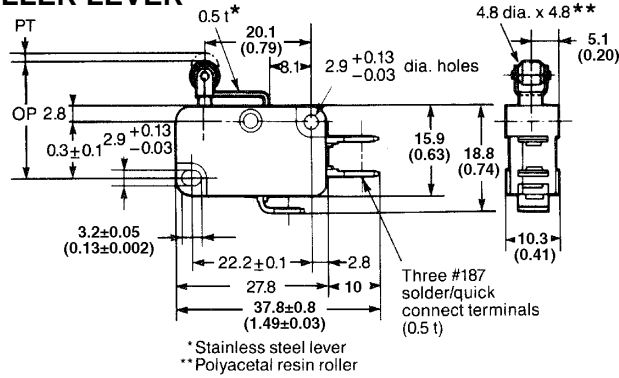

■ HINGE ROLLER LEVER

- V-15G6-1□5-K
- V-10G6-1□5-K
- V-10G6-1□4-K

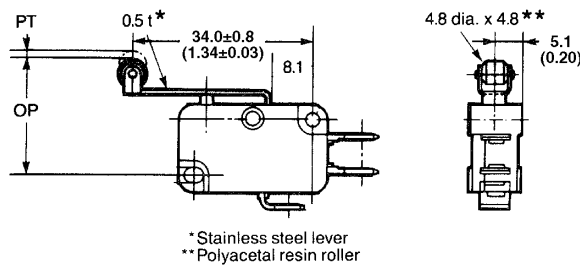

■ TERMINALS

General purpose type

Solder terminal (A)  
(or quick connect terminals  
#187 series)

Quick connect terminal (C2)  
(#187 series)

Quick connect terminal (C)  
(#250 series)

Common terminal position

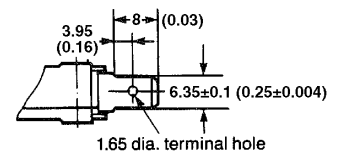
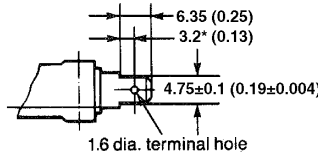
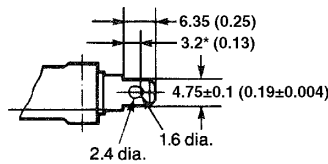

\*Indicates the length to the center of the 1.6 dia. holes.

Bottom type

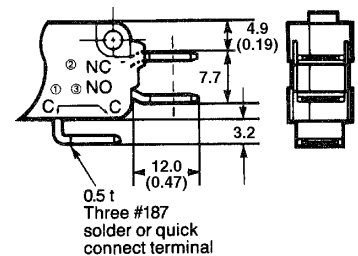
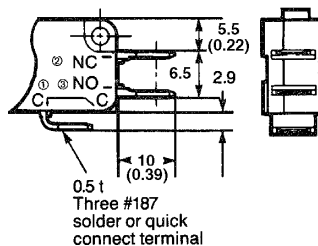
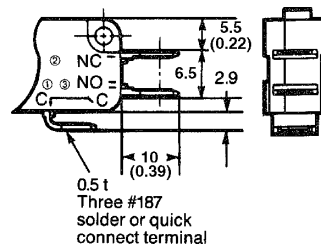

Unit: mm (inch)

**General purpose type**

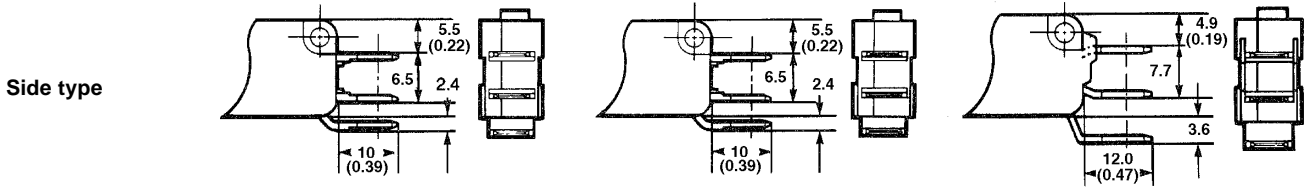

**Common terminal position**

**Short solder terminal (E)**

**Screw terminal (B)**

**Bottom terminal**

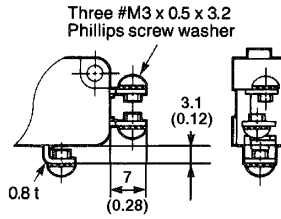
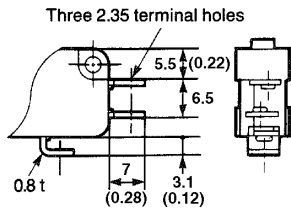

## Accessory Dimensions

### ■ ACTUATOR ACCESSORIES

Three series of actuators are optionally available: VAL, VAM, and VAV series.

The actuators in the VAL series are designated for rotary cam operations.

The VAM series actuators are highly resistive to vibration and shock; so, they are ideal for machine tools and automatic doors where the switches are subject to heavy vibration or shock.

The VAV series actuators are highly sensitive to force. Therefore, they should be used in an application where the operating force to be applied to the switch is critical.

All these actuators can be mounted on all OMRON snap action switches having the following dimensions.

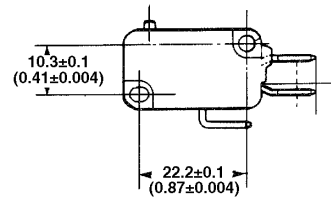

Note: 1. Unless otherwise specified, a tolerance of  $\pm 0.4$  mm applies to all dimensions.

2. The operating characteristics above apply when the actuator is attached to V-15-1A5-K basic switch. For any other models, consult OMRON.

### ■ LEAF SPRING VAL

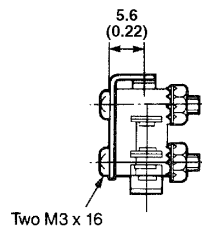
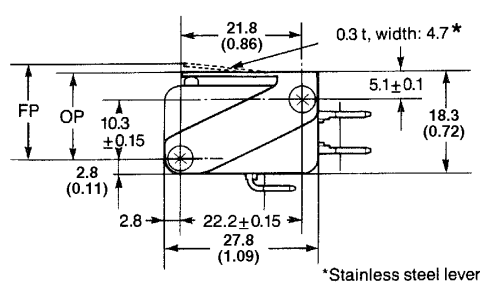



### ■ ROLLER LEAF SPRING VAL2

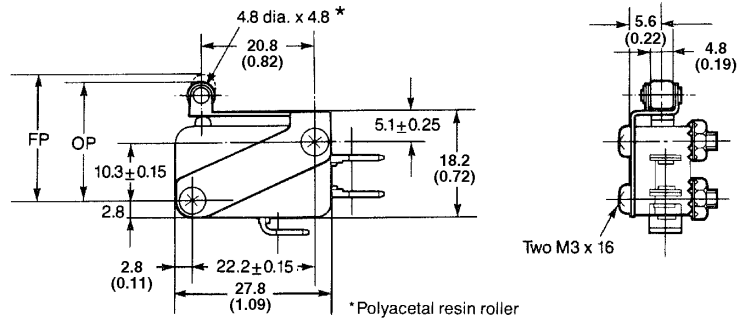

### ■ LONG HINGE LEVER VAV

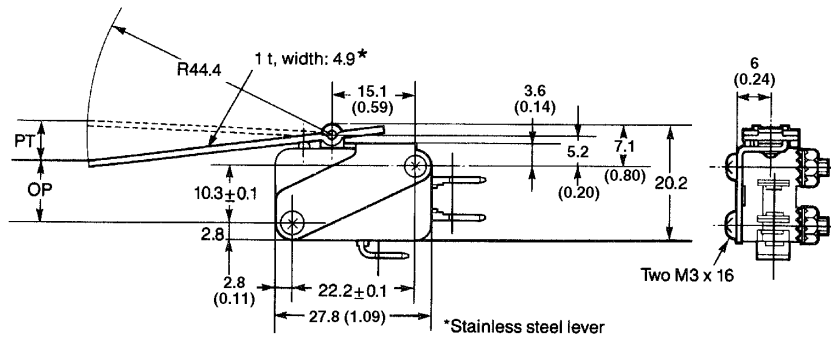

### ■ HINGE ROLLER LEVER VAV2

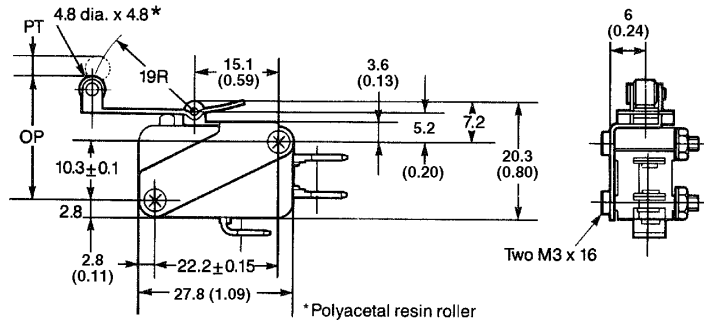

### ■ REVERSE-OPERATION, LONG HINGE LEVER VAM

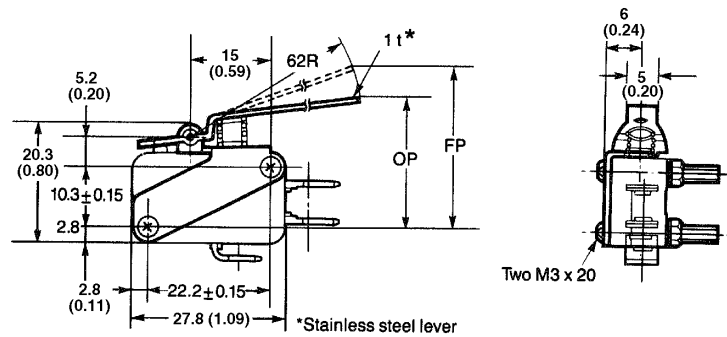

Unit: mm (inch)

## ■ REVERSE-OPERATION, SIMULATED ROLLER LEVER VAM-1

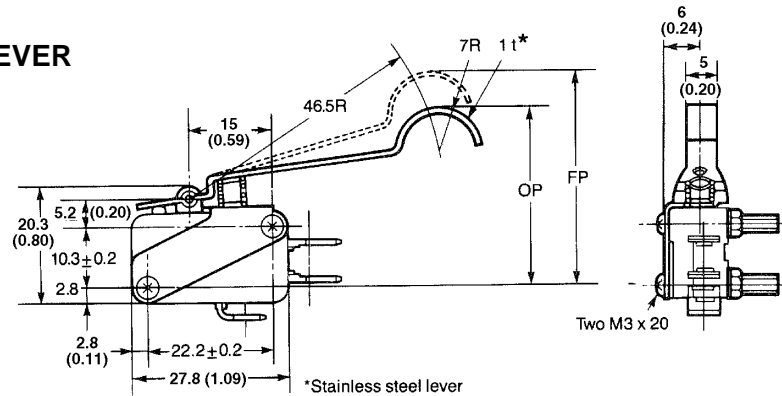

## Precautions

### ■ MOUNTING

The switch is mounted with two M3 screws. When doing so, use an appropriate screwdriver and tighten the screws at a torque of 4 to 6 kg-cm.

To solder the lead to the terminal, apply a soldering iron rated at 60 W max. quickly (within 5 seconds) with the actuator at the free position.

Note that applying a soldering iron for too long a time or using one that is rated at more than 60 W may degrade the switch characteristics.

### ■ OPERATION

Make sure that the operating body pushes the switch actuator with an adequate force when the switch is to be operated, and that it does not touch the actuator when the switch is released.

Do not change the operating position by modifying the actuator.

Do not use the switch in an application where the operating speed is extremely slow or the actuator is set in the midpoint between the free position and operating position.

Install the pin plunger switch so that the operating force is applied in alignment with the stroke of the actuator. The switch should be set so that its stroke is in the range of 60 to 90% of the rated OT (minimum value) when the switch has been operated.

**NOTE: DIMENSIONS ARE SHOWN IN MILLIMETERS. To convert millimeters to inches divide by 25.4.**

---

**OMRON**

**OMRON ELECTRONICS LLC.**

One East Commerce Drive  
Schaumburg, IL 60173  
**1-800-55-OMRON**

**OMRON ON-LINE**

Global - <http://www.omron.com>  
USA - <http://www.omron.com/oei>  
Canada - <http://www.omron.com/oci>

**OMRON CANADA, INC.**

885 Milner Avenue  
Scarborough, Ontario M1B 5V8  
**416-286-6465**