



SCHILL

connecting professionals

FT260

SPRING RETURN CABLE REEL

Small, robust wall ceiling or floor mounting spring-retractable reel, suitable for offices, small workshops, laboratories, schools & production areas.

Manufactured from sturdy thermoplastic, the reel is electrically insulated & corrosion resistant. Depending on requirements, the desired length of cable is pulled out of the reel, leaving the remaining cable neatly stored on the reel safe from damage and dirt.

When the cable connection is no-longer required, a short pull on the ball-stop and the cable neatly rewinds.



A spring-return cable reel means a safe & organized workplace.

FT260 Features:

- **FT260.0305-102 Voltage compatible for both 110v & 230v.**
- Load capacities up to 32A.
- Single & 3-phase 4 & 5-wire variants, including an earth-bonding version.
- Uprated spring variant's for lifting loads up to 1.2Kg.
- FT260.0305-101 pre-torqued to lift 450g loads consistently.
- Cable lengths from 5m to 12m - 1mm² to 4mm², in both HO5VV-F and HO7RN-F cables.
- Universal mounting bracket (Wall, floor or ceiling)
- Manual On/Off cable retraction ratchet
- Adjustable ball-stop
- High quality brass sliprings / sliver contacts
- IP20 protection



SCHILL

connecting professionals

Dimensions (mm):

A	B	C	D	E	F	G	H	J	K
260	140	60	22	22	175	36	122	26	325

Universal fixing bracket:

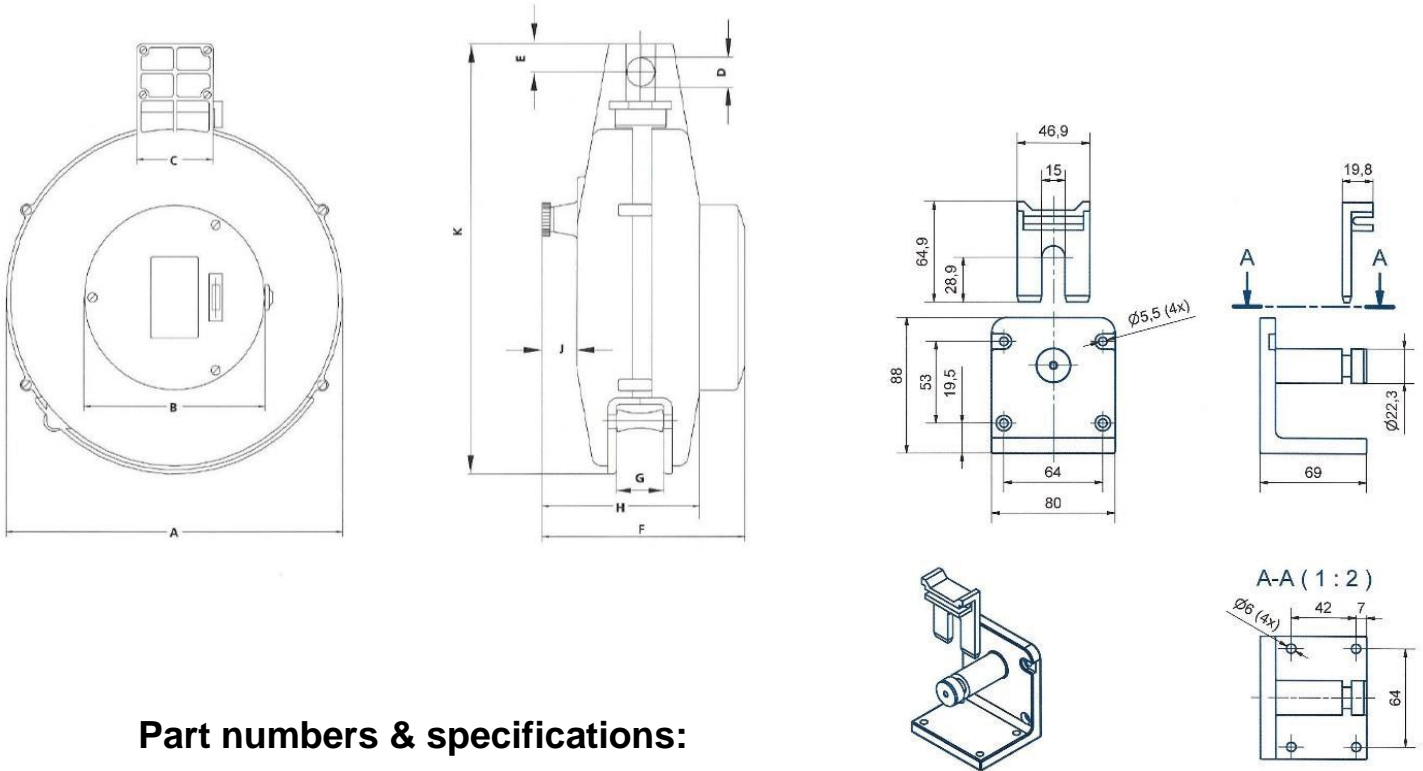

Part numbers & specifications:

Part Number	Cable	Load Wound	Load Unwound	Weight Kg
FT260.0312	12m 3x1mm ²	4A	10A	4.1
FT260.0308	8m 3x1.5mm ²	8A	10A*	4.0
FT260.0505	5m 5x1.5mm ²	5A	10A*	4.0
FTE260.0110	10m 1x10mm ²	Earth-Bond Reel	-	4.5
FT260.0406	6m 4x1.5mm ²	4A	10A*	4.0
FT260.0305	5m 3x2.5mm ²	8A	16A**	4.0
FT260.0305-102	5m 3x2.5mm²	8A	16A**	4.0
FT260.0305	5m 3x4.0mm ²	16A	32A**	5.0

*Can be increased to 16A by replacing the fused terminal block with an unfused terminal block.

Please ensure the cable is suitably protected.

** No internal fused block. Please ensure the cable is suitably protected.