

ZX1 & ZX2 SERIES

Compact displacement sensing



» All-in-one housing

» Highly stable measurement of any surface

» Plug & play - simple operation

The highest performance...

The ZX1 and ZX2 series of displacement sensors give you best-in-class speed, accuracy and ease-of-use. For example, it has a response time as low as 60 μ s and a measuring cycle as low as 30 μ s. Perhaps the best thing about the new ZX1 and ZX2 series is its highly stable measurement of any color or surface condition – including metals, plastics and shiny materials. The result? Superior quality assurance and optimized productivity for your machines.

Benefits

- Wide range of sensing distances
- Stable measurement for objects with any surface
- Best-in-class performance for accuracy and speed
- World's smallest sensing head - for easy mounting
- Simple configuration via one-button 'Smart Tuning'
- Reliable measurement in harsh environments
- Integrated display

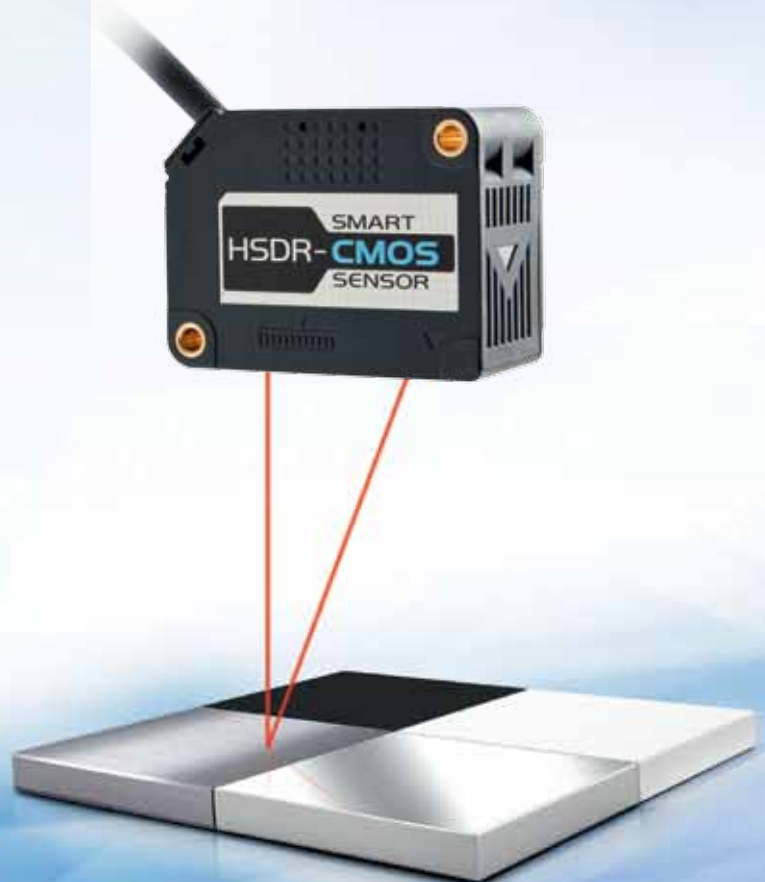

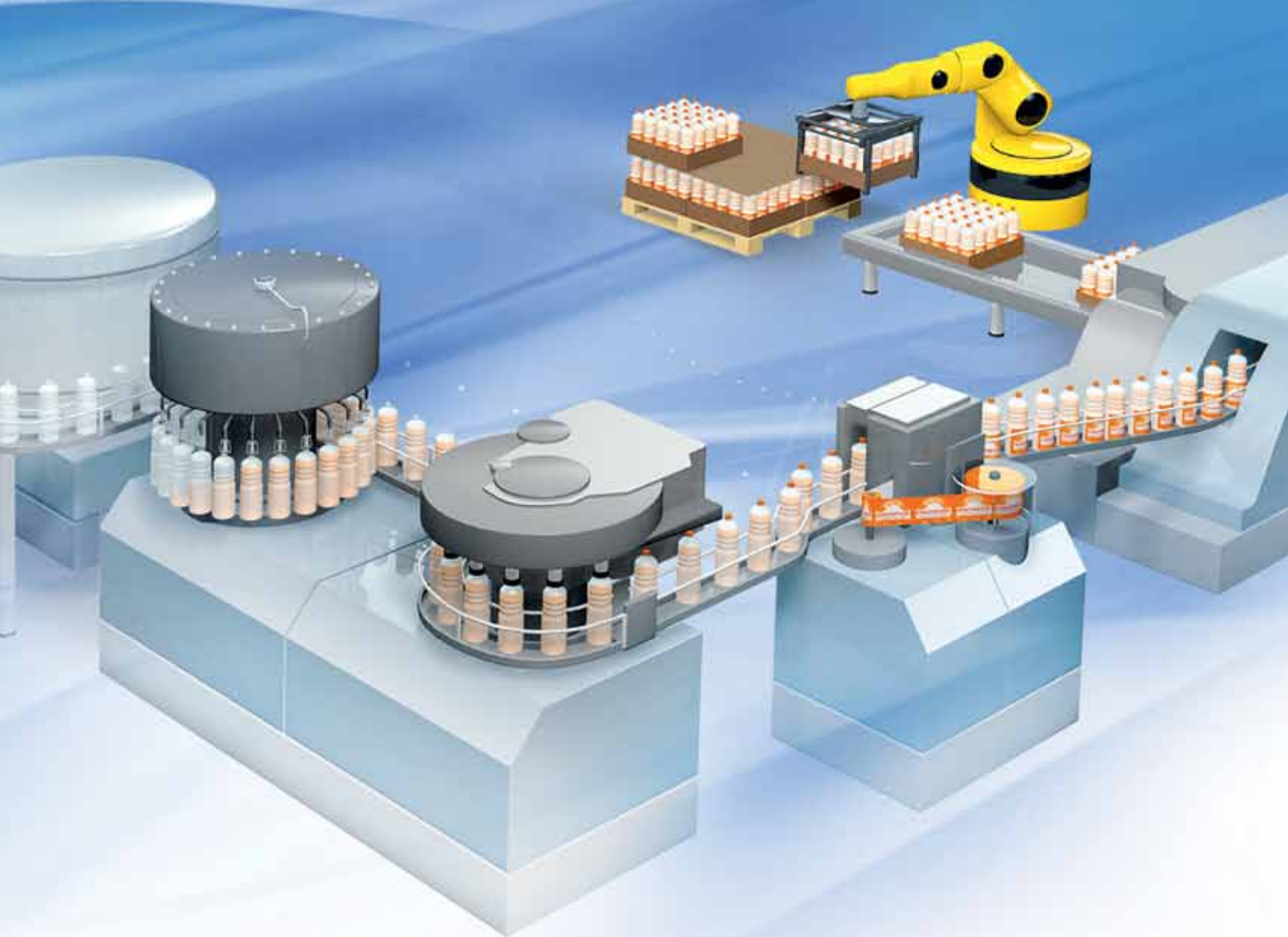

...for optimized productivity

Stable detection on any surface

The ZX1 and ZX2 easily handle previously difficult surfaces such as dark matt-type and shiny surfaces. This ability eliminates production line stoppages caused by sensor failure, and also minimizes stoppages caused when the target's surface is changed. This highly stable measurement is a result of the advanced HSDR (High Speed Dynamic Range) CMOS camera chip and the step-less laser power adjustment algorithm.

All-in-one housing

The ZX1 displacement sensor includes an integrated amplifier. So you only need to mount one component. This not only saves time and space but also simplifies cabling. In addition the ZX2 offers one of the world's smallest displacement sensor heads.

Plug & Play

These compact, easy-to-mount sensors are also easy to configure. Just one button press is all it takes to 'teach' the sensor about which surface type it is sensing. Perfect for fast machine installation, and ideal for use when product designs are changed.



One range - multiple applications

With Omron's new ZX1 and ZX2 displacement sensors you have the ideal solution for almost all of your displacement measuring tasks. For example, whether you need to check the tension of a paper-roll feed or the closure of a lid, the ZX1 and ZX2 measurement sensors provide a wide range of solutions to fit your application. That's because these precision measuring sensors are not only fast and highly reliable, they are also extremely flexible - with measuring distances from 20mm to 1000mm.

Detection of proper cap height



Double-sheet detection



Measuring material 'run-out'

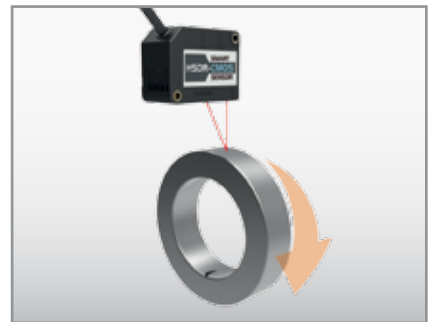

Measuring coil or spindle winding

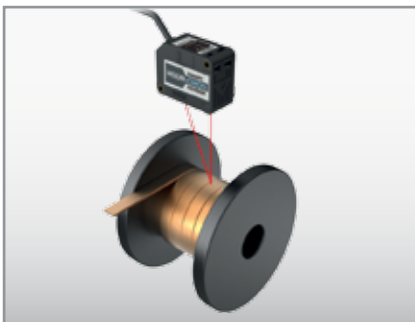

Confirming correct assembly

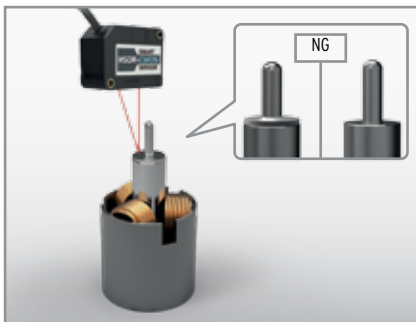

Quality assurance of molded products



ZX1 compact convenience

with integrated amplifier and all-in-one housing

Compact size for easy mounting

The highly compact displacement sensing head means that you can mount them in the smallest of spaces. The integrated LED display can be read with ease and there is no need to refer to a manual.

One-button press for easy 'teaching'

With a single button-press on the ZX1 you get the ideal configuration for your application. This means that set-up and calibration no longer depend on the skills of the operator. A reliable and optimized configuration is achieved by just one button-press.

IP67 for high reliability even in harsh environments

With an ingress protection rating of IP67 you are assured of highly reliable measurements even in harsh environments. Thanks to the robotic cable, the sensing head can even be mounted on moving parts.

Clear diagnostics for maximized productivity

When the laser approaches end-of-life, a built-in LED flashes. This enables maintenance to be implemented systematically, without causing an unscheduled production line stoppage.

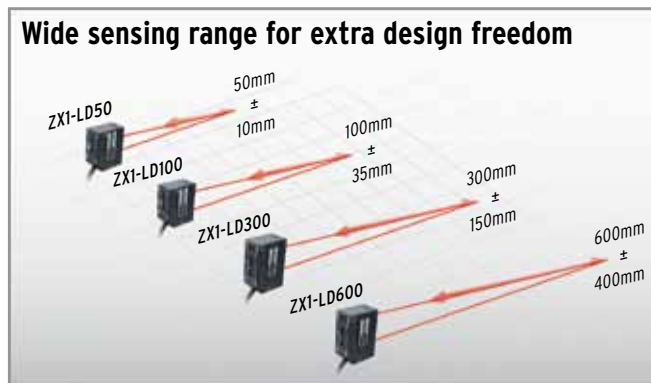

ZX2 advanced functionality

that's easy to use

Hold functions for more flexibility

With discrete hold functions equipped within the amplifier, the ZX2 provides a variety of measurement timing functions, which enable you to easily realize otherwise difficult measurement results. Five possible function values can be determined: average, peak-to-peak, sample, bottom and peak.

Scalable output for enhanced flexibility

The ZX2 includes a scaling function which allows you to configure the value on the digital display, as well as the analog output to the dimension of the application. The analog output can be configured to either output voltage or current.

Smart Tuning - for easy configuration

The ZX2 also has a one-button press function for fast and simple configuration, as well as offering the above advanced features for enhanced measuring.

Two calculations

Two ZX2 sensors can be used to measure the thickness or step for example, of a target. All you need to do is connect the calculating unit between the two amplifiers.

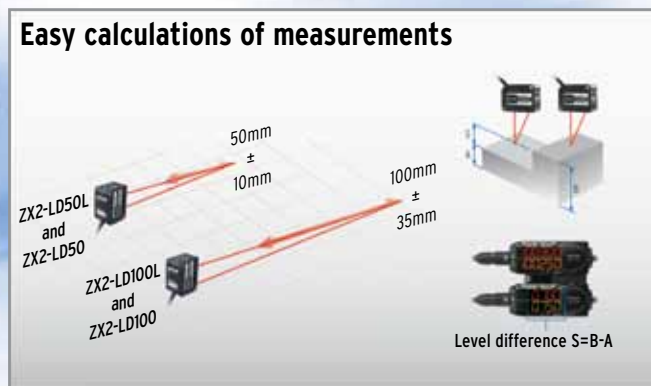

The complete range of Omron measurement sensors

As a total sensing solutions provider Omron offers a choice of inspection principles and technologies to provide the solution that best-fits your application. To ensure the highest inspection performance these smart measurement sensors offer accurate, reliable and fast measurement.

HIGH PERFORMANCE IN THE 3 MEASUREMENT DISCIPLINES



Displacement/Distance

In addition to the ZX1 and ZX2 series Omron offers the ZS family of laser sensors for ultra-critical applications. This provides outstanding measurement performance on all kinds of material and includes a very wide range of sensor heads as well as a scalable concept to provide a highly versatile platform. In addition, the new ZW Confocal Displacement Sensor has no electrical components and is therefore ideal for applications where there is high electrical and/or magnetic noise.

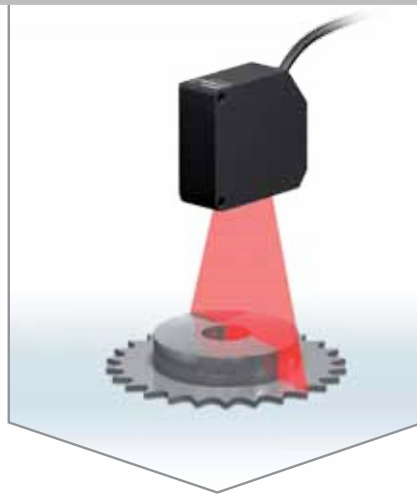

Profile measurement

The smart profile sensors in the ZG series provide an easy to use solution for scanning the profile of an object with a laser beam. Depending on the height, the laser beam is reflected differently and creates the profile information. By moving the sensor or the object, the complete surface can be inspected.

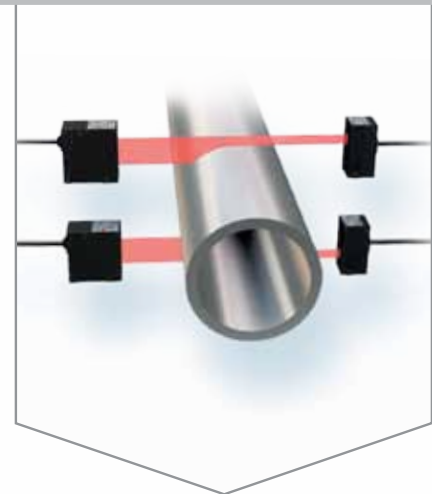

Position/Diameter/Width

Omron's ZX-GT smart laser micrometer is the perfect choice to accurately determine the position or diameter of an object. The object interrupts the laser beam, which allows the edges of an object to be determined.

ZW



ZS



ZG





ZX-GT

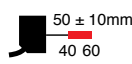
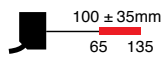

ZX1 Ordering Information

Sensor head with built-in amplifier

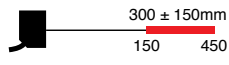
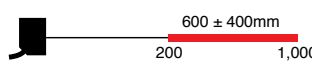
Appearance	Connection method	Cable length	Sensing distance	Model	
				NPN output	PNP output
	Pre-wired	2m		ZX1-LD50A61 2M	ZX1-LD50A81 2M
		5m		ZX1-LD50A61 5M	ZX1-LD50A81 5M
	Pre-wired connector	0.5m	ZX1-LD50A66 0.5M	ZX1-LD50A86 0.5M	
	Pre-wired	2m		ZX1-LD100A61 2M	ZX1-LD100A81 2M
		5m		ZX1-LD100A61 5M	ZX1-LD100A81 5M
	Pre-wired connector	0.5m	ZX1-LD100A66 0.5M	ZX1-LD100A86 0.5M	
	Pre-wired	2m		ZX1-LD300A61 2M	ZX1-LD300A81 2M
		5m		ZX1-LD300A61 5M	ZX1-LD300A81 5M
	Pre-wired connector	0.5m	ZX1-LD300A66 0.5M	ZX1-LD300A86 0.5M	
	Pre-wired	2m		ZX1-LD600A61 2M	ZX1-LD600A81 2M
		5m		ZX1-LD600A61 5M	ZX1-LD600A81 5M
	Pre-wired connector	0.5m	ZX1-LD600A66 0.5M	ZX1-LD600A86 0.5M	

Accessories (sold separately)

Extension Cables for Pre-wired Connector Models

An Extension Cable is not provided with the Sensor. Order an Extension Cable separately.

Cable length	Model
10m	ZX0-XC10R
20m	ZX0-XC20R

ZX2 Ordering Information

Sensor Heads

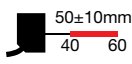
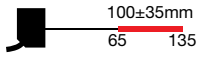
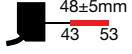
Appearance	Optical system	Beam shape	Sensing distance	Resolution	Model
	Diffuse reflective	Line beam		1.5 μm	ZX2-LD50L
		Spot beam			ZX2-LD50
		Line beam			ZX2-LD100L
		Spot beam			ZX2-LD100
	Regular reflective	Spot beam		1.5 μm	ZX2-LD50V

Accessories (sold separately)

These are not included with the Sensor Head or Amplifier Unit. Please order as necessary.

Amplifier Units

Appearance	Power supply	Output type	Model
	DC	NPN	ZX2-LDA11
		PNP	ZX2-LDA41

Calculating Unit

Appearance	Model
	ZX2-CAL



Accessories (sold separately) These are not included with the Sensor Head or Amplifier Unit. Please order as necessary.

Sensor Head Extension Cables

Cable Length	Model
1m	ZX2-XC1R
4m	ZX2-XC4R
9m	ZX2-XC9R
20m	ZX2-XC20R

* Extension cables cannot be coupled and used together.

Mounting Brackets

Applicable Sensor Heads	Appearance	Model	Contents
ZX2-LD50V ZX2-LD50L ZX2-LD50		E39-L178	Mounting Bracket: 1 Nut plate: 1 Phillips screws (M3×30): 2
ZX2-LD100L ZX2-LD100		E39-L179	

OMRON AUTOMATION AND SAFETY • THE AMERICAS HEADQUARTERS • Schaumburg, IL USA • 847.843.7900 • 800.556.6766 • www.omron247.com

OMRON CANADA, INC. • HEAD OFFICE

Toronto, ON, Canada • 416.286.6465 • 866.986.6766 • www.omron247.com

OMRON ELECTRONICS DE MEXICO • HEAD OFFICE

México DF • 52.55.59.01.43.00 • 001.800.556.6766 • mela@omron.com

OMRON ELECTRONICS DE MEXICO • SALES OFFICE

Apodaca, N.L. • 52.81.11.56.99.20 • 001.800.556.6766 • mela@omron.com

OMRON ELETRÔNICA DO BRASIL LTDA • HEAD OFFICE

São Paulo, SP, Brasil • 55.11.2101.6300 • www.omron.com.br

OMRON ARGENTINA • SALES OFFICE

Cono Sur • 54.11.4783.5300

OMRON CHILE • SALES OFFICE

Santiago • 56.9.9917.3920

OTHER OMRON LATIN AMERICA SALES

54.11.4783.5300

OMRON EUROPE B.V. • Wegalaan 67-69, NL-2132 JD, Hoofddorp, The Netherlands. • Tel: +31 (0) 23 568 13 00 • Fax: +31 (0) 23 568 13 88 • www.industrial.omron.eu

Authorized Distributor:

Automation Control Systems

- Machine Automation Controllers (MAC) • Programmable Controllers (PLC)
- Operator interfaces (HMI) • Distributed I/O • Software

Drives & Motion Controls

- Servo & AC Drives • Motion Controllers & Encoders

Temperature & Process Controllers

- Single and Multi-loop Controllers

Sensors & Vision

- Proximity Sensors • Photoelectric Sensors • Fiber-Optic Sensors
- Amplified Photomicrosensors • Measurement Sensors
- Ultrasonic Sensors • Vision Sensors • RFID/Code Readers

Industrial Components

- Relays • Pushbuttons & Indicators • Limit and Basic Switches • Timers
- Counters • Metering Devices • Power Supplies

Safety

- Laser Scanners • Safety Mats • Edges and Bumpers
- Programmable Safety Controllers • Light Curtains • Safety Relays
- Safety Interlock Switches