

## YASKAWA AC Drive Option **DeviceNet** Technical Manual

Type SI-N3

To properly use the product, read this manual thoroughly and retain for easy reference, inspection, and maintenance. Ensure the end user receives this manual.

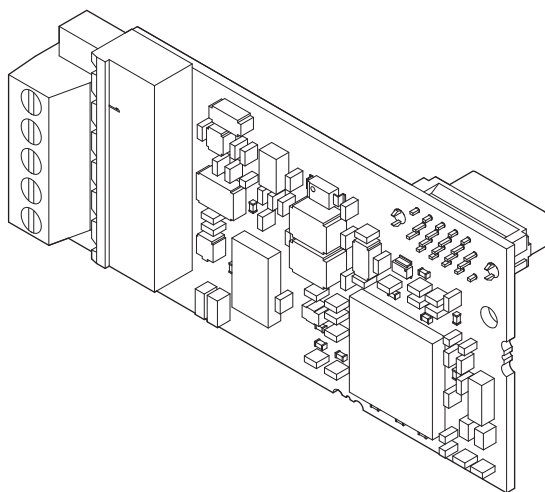

---

**Copyright © 2016 YASKAWA ELECTRIC CORPORATION**

All rights reserved. No part of this publication may be reproduced, stored in a retrieval system, or transmitted, in any form or by any means, mechanical, electronic, photocopying, recording, or otherwise, without the prior written permission of Yaskawa. No patent liability is assumed with respect to the use of the information contained herein. Moreover, because Yaskawa is constantly striving to improve its high-quality products, the information contained in this manual is subject to change without notice. Every precaution has been taken in the preparation of this manual. Yaskawa assumes no responsibility for errors or omissions. Neither is any liability assumed for damages resulting from the use of the information contained in this publication.

# Table of Contents

---

1	PREFACE AND SAFETY .....	4
2	OVERVIEW .....	7
3	RECEIVING .....	8
4	OPTION COMPONENTS .....	9
5	INSTALLATION PROCEDURE .....	11
6	RELATED PARAMETERS .....	26
7	CONFIGURING DEVICENET MESSAGING .....	29
8	OUTPUT ASSEMBLIES (DRIVE CONSUMES) .....	31
9	INPUT ASSEMBLIES (DRIVE PRODUCES) .....	54
10	GENERAL CLASS OBJECTS .....	82
11	VENDOR-SPECIFIC (YASKAWA) CLASS OBJECTS .....	93
12	TROUBLESHOOTING .....	95
13	TRUNK LINE AND DROP LINE LENGTH .....	100
14	EUROPEAN STANDARDS .....	101
15	SPECIFICATIONS .....	103

# 1 Preface and Safety

YASKAWA Electric supplies component parts for use in a wide variety of industrial applications. The selection and application of YASKAWA products remain the responsibility of the equipment designer or end user. YASKAWA accepts no responsibility for the way its products are incorporated into the final system design. Under no circumstances should any YASKAWA product be incorporated into any product or design as the exclusive or sole safety control. Without exception, all controls should be designed to detect faults dynamically and fail safely under all circumstances. All products designed to incorporate a component part manufactured by YASKAWA must be supplied to the end user with appropriate warnings and instructions as to the safe use and operation of that part. Any warnings provided by YASKAWA must be promptly provided to the end user. YASKAWA offers an express warranty only as to the quality of its products in conforming to standards and specifications published in the manual. **NO OTHER WARRANTY, EXPRESS OR IMPLIED, IS OFFERED.** YASKAWA assumes no liability for any personal injury, property damage, losses, or claims arising from misapplication of its products.

## ◆ Applicable Documentation

The following manuals are available for the option:

### SI-N3 Option

<b>YASKAWA AC Drive Option SI-N3 DeviceNet Installation Manual Manual No: TOBP C730600 84</b>	This guide is packaged together with the product and contains information necessary to install the option and set related drive parameters.
<b>YASKAWA AC Drive Option SI-N3 DeviceNet Technical Manual Manual No: SIEP C730600 84 (This book)</b>	The technical manual contains detailed information about the option. Access the following sites to obtain the technical manual: U.S.: <a href="http://www.yaskawa.com">http://www.yaskawa.com</a> Europe: <a href="http://www.yaskawa.eu.com">http://www.yaskawa.eu.com</a> Japan: <a href="http://www.e-mechatronics.com">http://www.e-mechatronics.com</a> Other areas: Check the back cover of these manuals. For questions, contact Yaskawa or a Yaskawa representative.

### Drive

<b>YASKAWA AC Drive Manuals</b>	Drive manuals contain basic installation and wiring information in addition to detailed parameter setting, fault diagnostic, and maintenance information. The most recent versions of these manuals are available for download on our documentation websites: U.S.: <a href="http://www.yaskawa.com">http://www.yaskawa.com</a> Europe: <a href="http://www.yaskawa.eu.com">http://www.yaskawa.eu.com</a> Japan: <a href="http://www.e-mechatronics.com">http://www.e-mechatronics.com</a> Other areas: Check the back cover of these manuals. For questions, contact Yaskawa or a Yaskawa representative.
-------------------------------------	--

## ◆ Terms

<b>Note:</b>	Indicates supplemental information that is not related to safety messages.
<b>Option:</b>	YASKAWA AC Drive DeviceNet Option
<b>Drive:</b>	<ul style="list-style-type: none"> <li>• YASKAWA AC Drive 1000-Series (A1000, E1000, H1000, L1000A, U1000, Z1000U, Z1000)</li> <li>• YASKAWA AC Drive GA700</li> <li>• YASKAWA AC Drive GA800</li> </ul>
<b>Keypad:</b>	<ul style="list-style-type: none"> <li>• LCD Operator for YASKAWA AC Drive 1000-Series</li> <li>• LED Operator for YASKAWA AC Drive 1000-Series</li> <li>• LCD Keypad for YASKAWA AC Drive GA700 and GA800</li> <li>• LED Keypad for YASKAWA AC Drive GA700 and GA800</li> </ul>
<b>OLV:</b>	Open Loop Vector Control
<b>CLV:</b>	Closed Loop Vector Control
<b>AOLV:</b>	Advanced Open Loop Vector Control
<b>AOLV/PM:</b>	Advanced Open Loop Vector Control for PM
<b>CLV/PM:</b>	Closed Loop Vector Control for PM
<b>EZOLV:</b>	EZ Open Loop Vector Control

## ◆ Registered Trademarks

- DeviceNet is a trademark of the ODVA.
- Trademarks are the property of their respective owners.

## ◆ Supplemental Safety Information

Read and understand this manual before installing, operating, or servicing this option. Install the option according to this manual and local codes.

The following conventions indicate safety messages in this manual. Failure to heed these messages could cause fatal injury or damage products and related equipment and systems.

### DANGER

Indicates a hazardous situation, which, if not avoided, will cause death or serious injury.

### WARNING

Indicates a hazardous situation, which, if not avoided, could cause death or serious injury.

### CAUTION

Indicates a hazardous situation, which, if not avoided, could cause minor or moderate injury.

### NOTICE

Indicates an equipment damage message.

### ■ General Safety

#### General Precautions

- The diagrams in this book may include options and drives without covers or safety shields to illustrate details. Be sure to reinstall covers or shields before operating any devices. Use the option according to the instructions described in this manual.
- The diagrams in this manual are provided as examples only and may not pertain to all products covered by this manual.
- The products and specifications described in this manual or the content and presentation of the manual may be changed without notice to improve the product and/or the manual.
- Contact Yaskawa or a Yaskawa representative and provide the manual number shown on the front cover to order new copies of the manual.

#### DANGER

##### **Heed the safety messages in this manual.**

Failure to comply will cause death or serious injury.

The operating company is responsible for any injuries or equipment damage resulting from failure to heed the warnings in this manual.

#### WARNING

##### **Electrical Shock Hazard**

**Do not attempt to modify or alter the drive or drive circuitry in any way not explained in this manual.**

Failure to comply could cause death or serious injury and will void warranty. Yaskawa is not responsible for any modification of the product made by the user. Do not modify this product.

#### NOTICE

**Do not modify the drive or option circuitry.**

Failure to comply could result in damage to the drive or option and will void warranty. Yaskawa is not responsible for any modification of the product made by the user.

**Do not expose the drive or the option to halogen group disinfectants. Do not pack the drive or the option in fumigated or sterilized wooden materials. Do not sterilize the entire package after packing the product.**

Failure to comply could damage electrical components in the option.

## 2 Overview

The SI-N3 Option provides a communications connection between the drive and an ODVA DeviceNet network. The SI-N3 Option connects the drive to a DeviceNet network and facilitates the exchange of data.

DeviceNet is a communications link that connects industrial devices (e.g., limit switches, photoelectric switches, valve manifolds, motor starters, smart motor controllers, operator interfaces, and variable frequency drives) and control devices (e.g., programmable controllers and computers) to a network. DeviceNet is a simple networking solution that reduces the cost and time to wire and install factory automation devices while providing interchangeability of similar components from multiple vendors.

Install the option/DeviceNet option on a drive to perform the following functions from a DeviceNet master device:

- Operate the drive
- Monitor the drive operation status
- Change drive parameter settings



Figure 1 DeviceNet Approved

### ◆ Compatible Products

The option can be used with the products in [Table 1](#).

Table 1 Compatible Products

Product Series	Model(s)
A1000	All models
E1000	All models
H1000	All models
L1000A <1>	All models
U1000 <2>	All models
Z1000U <2>	All models
Z1000	All models
GA700 <2>	All models
GA800 <2>	All models

<1> Before you install the option on a YASKAWA L1000A-, U1000-, or Z1000U-Series Drives, make sure that the option software version is PRG: 1112 or later.

<2> Before you install the option on a YASKAWA AC Drive GA700 or GA800, make sure that the option software version is PRG: 1115 or later.

- Note:**
1. Refer to the option package labeling in the field designated “PRG” (four digit number)” or the option labeling in the field designated “C/N” (S + four digit number)” to identify the option software version.
  2. For Yaskawa customers in the North or South America region:  
If your product is not listed in [Table 1](#), refer to the web page below to confirm this manual is correct for your product. The web page provides a list of option manuals by product, and a direct link to download a PDF.

Scan QR code



Or refer to: <http://www.yaskawa.com/optionlookup>

## 3 Receiving





After receiving the option package:

1. Make sure that the option is not damaged and no parts are missing. Contact your sales outlet if the option or other parts appear damaged.

**NOTICE:** Do not use damaged parts to connect the drive and the option. Failure to comply could damage the drive and option.

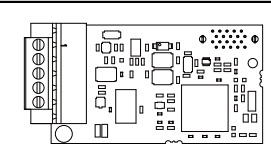
2. Confirm that the model number on the option nameplate and the model listed in the purchase order are the same. Refer to **Figure 2** on page 9 for details. Contact the distributor where the option was purchased or contact Yaskawa or a Yaskawa representative about any problems with the option.

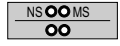
### ◆ Option Package Contents

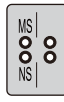
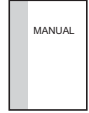
Description:	Option	Ground Wire <1>	Screws (M3)	LED Labels			Installation Manual
				A1000, E1000, H1000, L1000A, U1000, Z1000U	Z1000	GA700 and GA800	
-							
<b>Quantity:</b>	1	1	3 <2>	1	1	1	1

<1> GA700 and GA800 drives do not use the ground wire.

<2> GA700 and GA800 drives use two screws only.

### ◆ Installation Tools

- A Phillips screwdriver. Phillips screw sizes vary by drive capacity.
- A flat-blade screwdriver (blade depth: 0.4 mm (0.02 in), width: 2.5 mm (0.1 in)).
- A pair of diagonal cutting pliers.
- A small file or medium-grit sandpaper.



## 4 Option Components

### ◆ DeviceNet Option

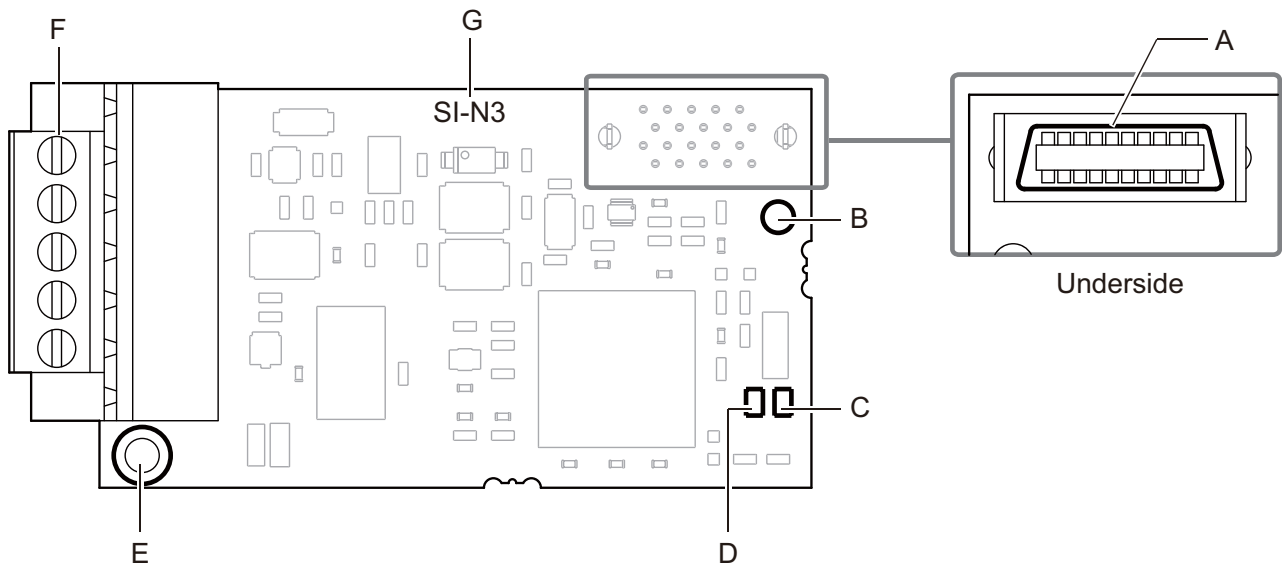

A – Connector (CN5)

B – Installation hole

C – LED (MS) <1>

D – LED (NS) <1>

E – Ground terminal (FE) and installation hole <2>

F – Terminal block CN1

G – Option model number

<1> Refer to [Option LED Display on page 10](#) for details on the LEDs.

<2> Connect the provided ground wire during installation. Installation on GA700 and GA800 drives does not require the ground wire.

Figure 2 DeviceNet Option Components

### ◆ Terminal Block CN1

The communication terminal is a pluggable terminal block that serves as the connection point of the DeviceNet network communication cable to the option.

Table 2 Terminal Descriptions

Terminal	Pin	Color	Signal	Description
	1	Black	V-	Network common
	2	Blue	CAN_L	CAN data Low
	3	–	Shield	Cable shield
	4	White	CAN_H	CAN data High
	5	Red	V+	Communications network power DC +24V

## 4 Option Components

### ◆ Option LED Display

The option has two bicolor, red/green LEDs: one for Module Status (MS) and one for Network Status (NS).

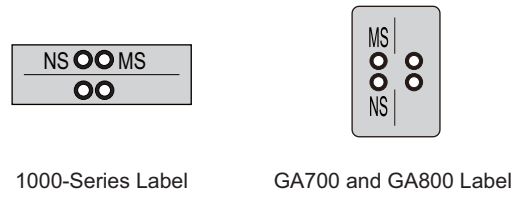

**Figure 3 Option LED Labels**

The operational states of the LEDs after completion of the DeviceNet power-up diagnostic LED sequence are described in [Table 4](#). Wait at least 2 seconds for the power-up diagnostic process to complete before verifying the states of the LEDs.

**Table 3 Option LED States**

Name	Display		Operating Status	Description
	Color	Status		
MS	–	OFF	Power supply OFF	Power is not being supplied to the drive.
	Green	ON	Option operating	The option is operating normally.
	Green	Flashing	Option initializing	There is an incorrect baud rate setting or there is a MAC ID.
	Red	ON	Fatal error occurred	A fatal (irrecoverable) error occurred in the option.
	Red	Flashing	Non-fatal error occurred	A non-fatal (recoverable) error occurred.
	Green/Red	Flashing	Device self-test	Device in self-test mode.
NS	–	OFF	Offline or Power supply OFF	–
	Green	ON	Online communications established	Device is on-line and has connections in the established state.
	Green	Flashing	Online communications not established	Device is on-line but has no connections in the established state. Duplicate MAC ID test has been passed and is on-line but has no open connections to other nodes.
	Red	ON	Communications error	An error occurred disabling DeviceNet communications. <ul style="list-style-type: none"> <li>• MAC ID duplication</li> <li>• Bus off detected</li> </ul>
	Red	Flashing	Communications time-out	A communications time-out occurred with the master.
	Green/Red	Flashing	Communication faulted	Specific communication faulted device. <ul style="list-style-type: none"> <li>• The device has detected a network access error and is in the communications faulted state.</li> <li>• The device has then received and accepted an Identify communication fault request-long protocol message.</li> </ul>

### ■ Power-Up Diagnostics

An LED test is performed each time the drive is powered up. The initial boot sequence may take several seconds. The option is successfully initialized when the LEDs complete the diagnostic LED sequence. The LEDs then assume operational conditions shown in [Table 3](#).

**Table 4 Power-Up Diagnostic LED Sequence**

Sequence	Module Status (MS)	Network Status (NS)	Time (ms)
1	Green	OFF	250
2	Red	OFF	250
3	Green	Green	250
4	Green	Red	250
5	Green	OFF	-

## 5 Installation Procedure

### ◆ Section Safety

#### DANGER

##### Electrical Shock Hazard

**Do not inspect, connect, or disconnect any wiring while the drive is energized.**

Failure to comply will cause death or serious injury.

Before servicing, disconnect all power to the equipment and wait for at least the time specified on the warning label. The internal capacitor remains charged even after the drive is de-energized. The charge indicator LED will extinguish when the DC bus voltage is below 50 Vdc. When all indicators are OFF, measure for unsafe voltages to confirm the drive is safe.

#### WARNING

##### Electrical Shock Hazard

**Do not operate equipment with covers removed.**

Failure to comply could cause death or serious injury.

The diagrams in this section may include options and drives without covers or safety shields to illustrate details. Reinstall covers and shields before operating the drive and run the drive according to the instructions described in this manual.

**Do not allow unqualified personnel to perform work on the drive or option.**

Failure to comply could cause death or serious injury.

Only authorized personnel familiar with installation, adjustment, and maintenance of AC drives and options may perform work.

**Do not remove covers or touch circuit boards while the drive is energized.**

Failure to comply could cause death or serious injury.

**Do not use damaged wires, stress the wiring, or damage the wire insulation.**

Failure to comply could cause death or serious injury.

##### Fire Hazard

**Tighten all terminal screws to the specified tightening torque.**

Loose or overtightened connections could cause erroneous operation and damage to the terminal block or start a fire and cause death or serious injury.

#### NOTICE

##### Damage to Equipment

**Observe proper electrostatic discharge (ESD) procedures when handling the option, drive, and circuit boards.**

Failure to comply could cause ESD damage to circuitry.

**Never connect or disconnect the motor from the drive while the drive is outputting voltage.**

Improper equipment sequencing could damage the drive.

**Do not connect or operate any equipment with visible damage or missing parts.**

Failure to comply could further damage the equipment.

**Do not use unshielded wire for control wiring.**

Failure to comply may cause electrical interference resulting in poor system performance. Use shielded, twisted-pair wires and ground the shield to the ground terminal of the drive.

### NOTICE

**Properly connect all pins and connectors on the option and drive.**

Failure to comply could prevent proper operation and damage equipment.

**Confirm that all connections are correct after installing the option and connecting peripheral devices.**

Failure to comply could damage the option.

### ◆ Procedures for Installing and Wiring Options on a Drive

Procedures for installing and wiring options differ depending on the drive model.

Refer to [Table 5](#) to check the procedures for installing and wiring options on a drive.

**Table 5 Procedures for Installing and Wiring Options on a Drive**

Product Series	Procedures for Installing and Wiring Options on a Drive	Page
A1000	Procedure A	<a href="#">13</a>
E1000	Procedure A	<a href="#">13</a>
H1000	Procedure A	<a href="#">13</a>
L1000A	Procedure A	<a href="#">13</a>
U1000	Procedure A	<a href="#">13</a>
Z1000U	Procedure A	<a href="#">13</a>
Z1000	Procedure B	<a href="#">17</a>
GA700	Procedure C	<a href="#">21</a>
GA800	Procedure C	<a href="#">21</a>

## ■ Procedure A

This section shows the procedure to install and wire the option on a 1000-series drive.

### Prepare the Drive for the Option

Before you install the option on a YASKAWA L1000A-, U1000-, or Z1000U-Series Drive, make sure that the option software version is PRG: 1112 or later.

1. Correctly wire the drive as specified by the manual packaged with the drive.
2. Make sure that the drive functions correctly.

Refer to [Figure 4](#) for an exploded view of the drive with the option and related components for reference in the installation procedure.

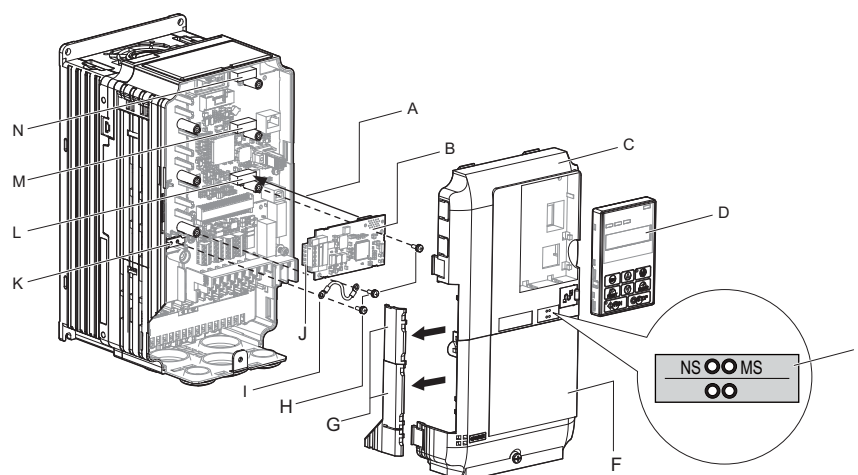

- |  |  |
|--|--|
| <b>A</b> – Insertion point for CN5         | <b>J</b> – Option terminal block (CN1)                 |
| <b>B</b> – Option card                     | <b>K</b> – Drive grounding terminal (FE)               |
| <b>C</b> – Front cover                     | <b>L</b> – Connector CN5-A                             |
| <b>D</b> – Keypad                          | <b>M</b> – Connector CN5-B                             |
| <b>E</b> – LED label                       | (Not available for communication option installation.) |
| <b>F</b> – Terminal cover                  | <b>N</b> – Connector CN5-C                             |
| <b>G</b> – Removable tabs for wire routing | (Not available for communication option installation.) |
| <b>H</b> – Included screws                 |  |
| <b>I</b> – Ground wire                     |  |

Figure 4 Drive Components with Option

## 5 Installation Procedure

### Install the Option

Remove the front covers of the drive before you install the option. Refer to the drive manual for information about how to remove the front covers. Different drive sizes have different cover removal procedures. You can only install this option into the CN5-A connector on the drive control board.

**DANGER! Electrical Shock Hazard.** Do not inspect, connect, or disconnect any wiring while the drive is energized. Failure to comply will cause death or serious injury. Before servicing, disconnect all power to the equipment and wait for at least the time specified on the warning label. The internal capacitor remains charged even after the drive is de-energized. The charge indicator LED will extinguish when the DC bus voltage is below 50 Vdc. When all indicators are OFF, measure for unsafe voltages to confirm the drive is safe.

1. Shut off power to the drive, wait the appropriate amount of time for voltage to dissipate, then remove the keypad (D) and front covers (C, F).  
Refer to the manual packaged with the drive for details on keypad and cover removal.

**NOTICE: Damage to Equipment.** Observe proper electrostatic discharge (ESD) procedures when handling the option, drive, and circuit boards. Failure to comply could cause ESD damage to circuitry.

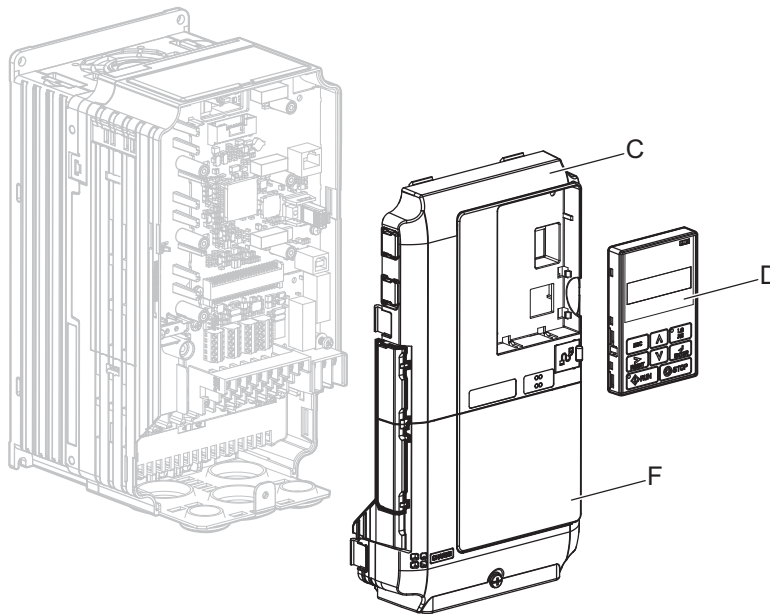

Figure 5 Remove the Keypad, Front Cover, and Terminal Cover

2. Affix the LED label (E) in the appropriate position on the drive front cover (C).

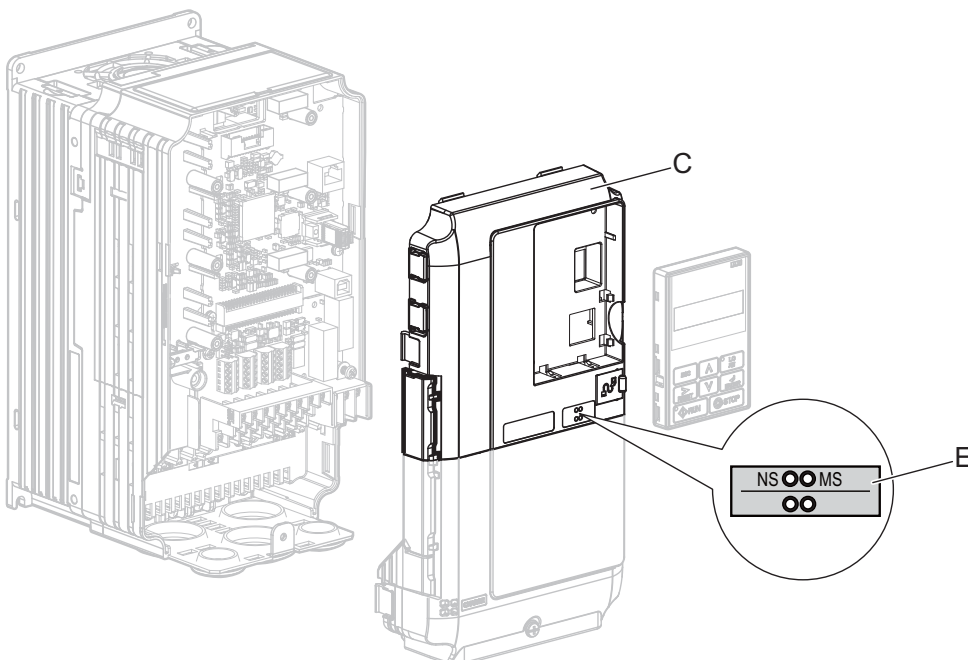

Figure 6 Affix the LED Label

3. Insert the option card (B) into the CN5-A (L) connector on the drive and fasten it into place using one of the included screws (H). Tighten the screw to 0.5 to 0.6 N·m (4.4 to 5.3 in·lb).

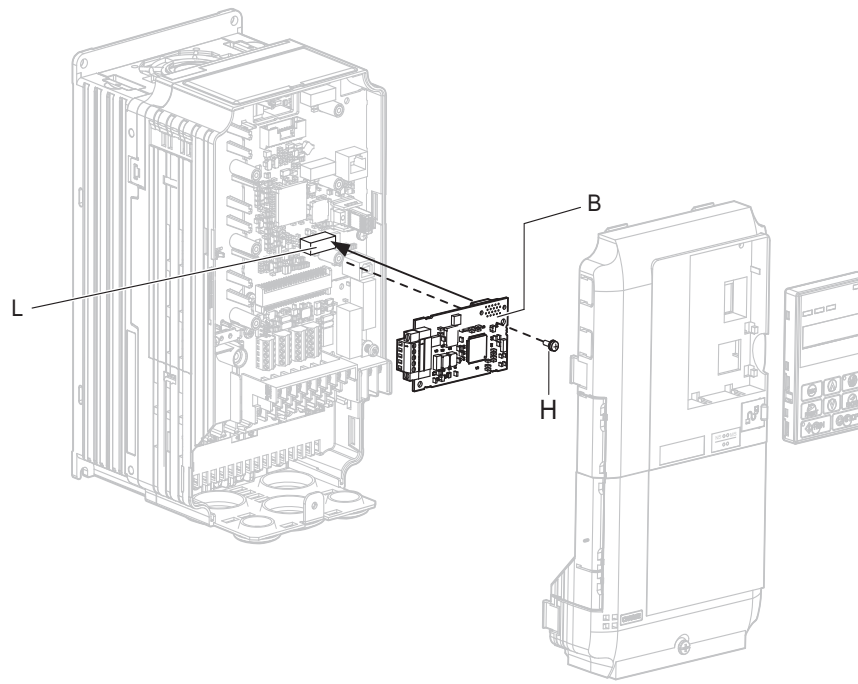

Figure 7 Insert the Option Card

4. Connect one end of the ground wire (I) to the ground terminal (K) using one of the remaining provided screws (H). Connect the other end of the ground wire (I) to the remaining ground terminal and installation hole on the option (B) using the last remaining provided screw (H). Tighten both screws to 0.5 to 0.6 N·m (4.4 to 5.3 in·lb).

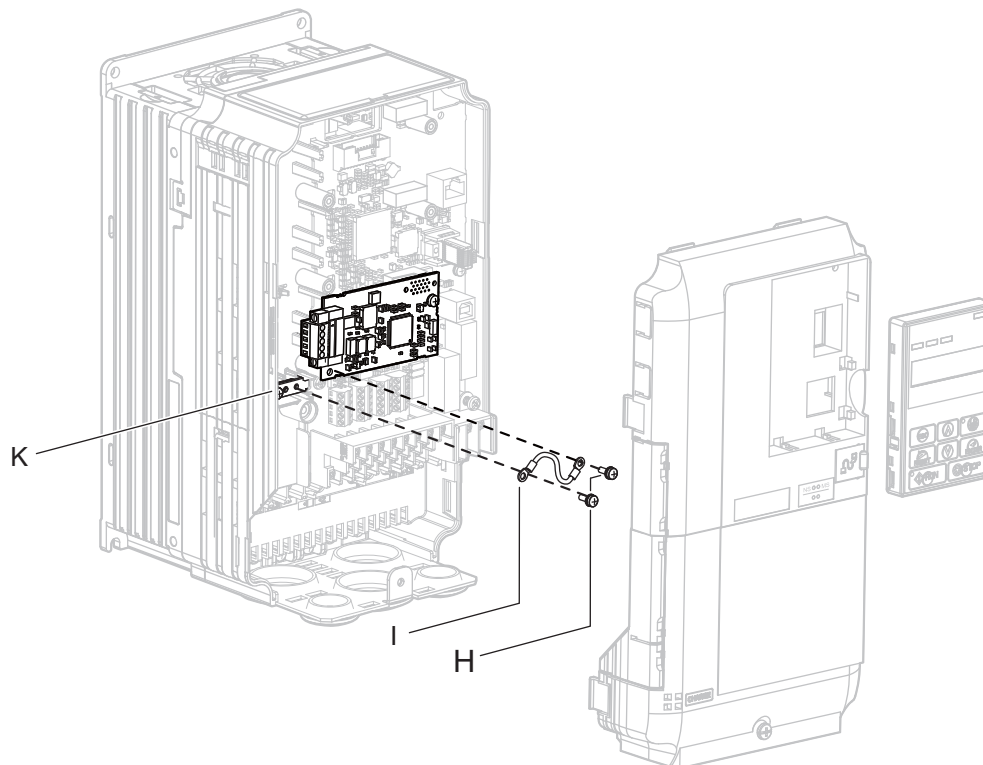

Figure 8 Connect the Ground Wire

**Note:** The drive has only two ground terminal screw holes (K). Two ground wires should share the same ground terminal when connecting three options.

## 5 Installation Procedure

5. Firmly connect the DeviceNet communication cable to option terminal block (CN1).  
Install DeviceNet communications cables apart from main-circuit wiring and other electrical and power lines. Ensure the cable end is firmly connected (see [Figure 22](#)). Refer to [Communication Cable Topology on page 24](#) for details.
6. Reattach the drive front covers (C, F) and the keypad (D).

**NOTICE:** Do not pinch cables between the front covers and the drive. Failure to comply could cause erroneous operation.

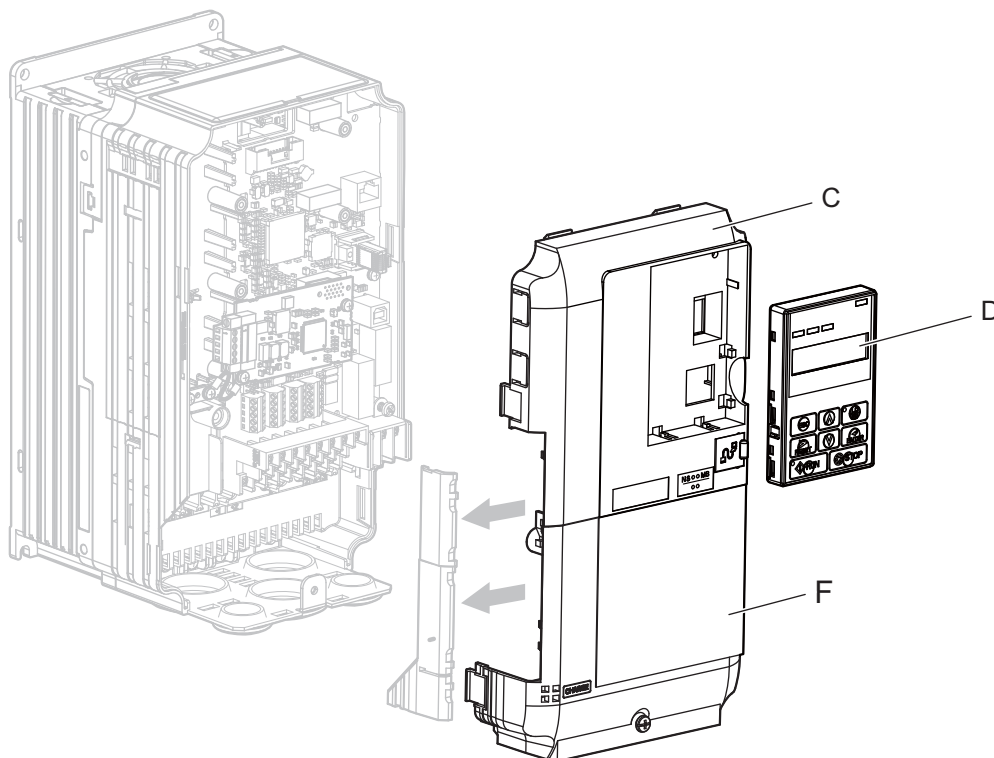

**Figure 9 Replace the Front Covers and Keypad**

7. Set drive parameters in [Table 7](#) for correct option performance.



## ■ Procedure B

This section shows the procedure to install and wire the option on a Z1000 drive.

### Prepare the Drive for the Option

Prior to installing the option, wire the drive, make necessary connections to the drive terminals, and verify that the drive functions normally without the option installed. Refer to the User Manual packaged with the drive for information on wiring and connecting the drive.

*Figure 10* shows an exploded view of the drive with the option and related components for reference.

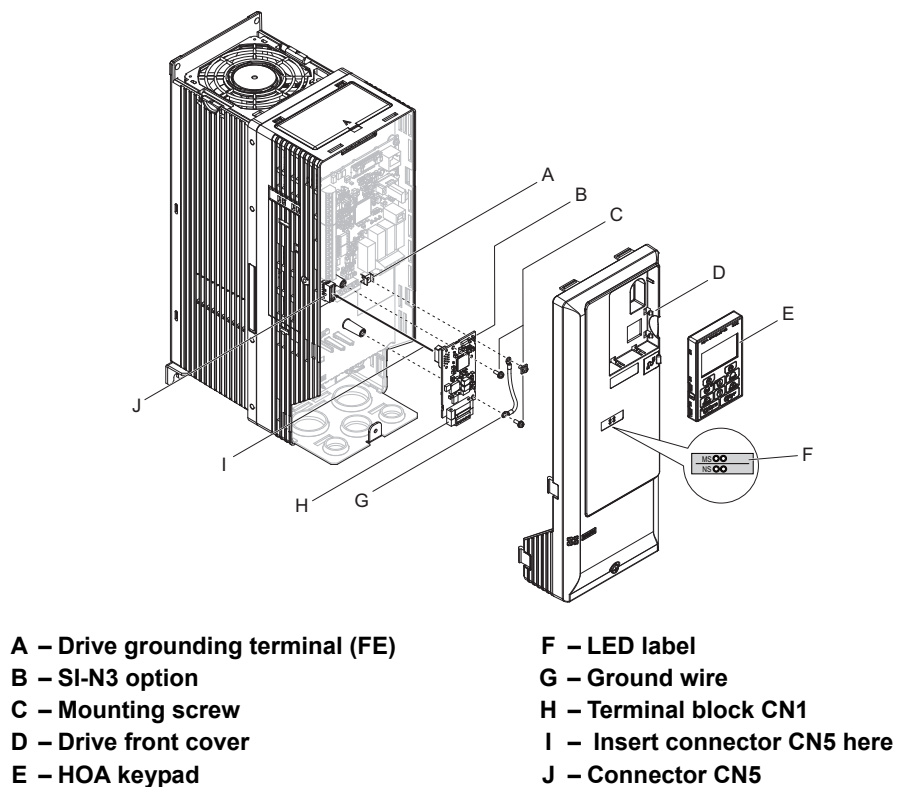

**Figure 10 Drive Components with Option**

## 5 Installation Procedure

### Installing the Option

Remove the front cover of the drive before you install the option.

Refer to the drive manual for information about how to remove the front covers. Different drive sizes have different cover removal procedures.

You can only install this option into the **CN5-A** connector on the drive control board.

**DANGER! Electrical Shock Hazard.** Do not connect or disconnect wiring while the power is on. Failure to comply could result in death or serious injury. Before installing the option, disconnect all power to the drive and wait at least the amount of time specified on the drive front cover safety label. After all indicators are off, measure the DC bus voltage to confirm safe level, and check for unsafe voltages before servicing. The internal capacitor remains charged after the power supply is turned off.

1. Shut off power to the drive, wait the appropriate amount of time for voltage to dissipate, then remove the HOA keypad (E) and front cover (D).

**NOTICE: Damage to Equipment.** Observe proper electrostatic discharge procedures (ESD) when handling the option, drive, and circuit boards. Failure to comply may result in ESD damage to circuitry.

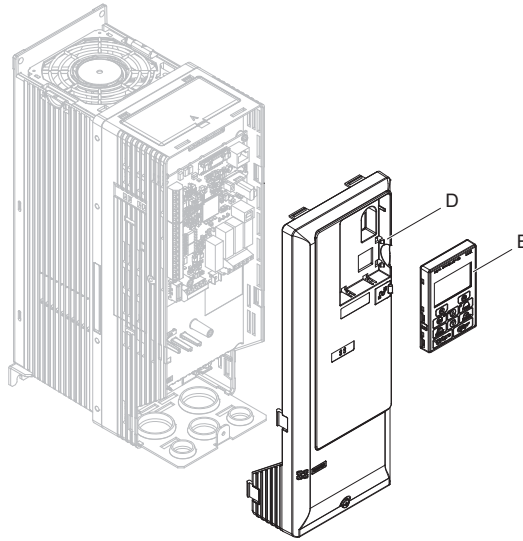

**Figure 11 Remove the Front Cover and HOA Keypad**

2. With the front cover and HOA keypad removed, apply the LED label (F) in the appropriate position on the drive front cover (D).

**Note:** Place the LED label vertically on Z1000 drives as shown in *Figure 12*.

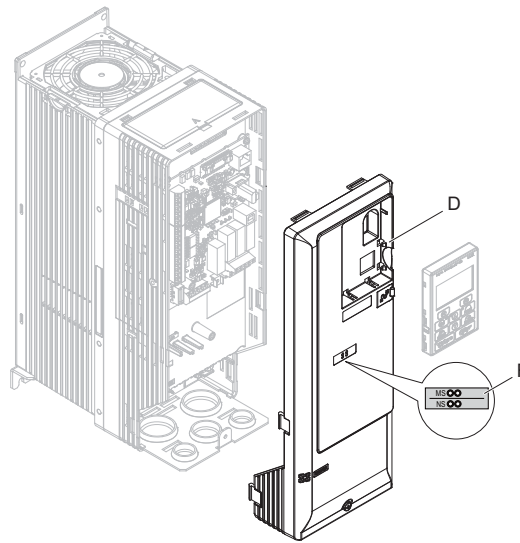

**Figure 12 Apply the LED Label**

3. Make sure the screws on the left and right sides of the option terminal block (H) are tightened with a tightening torque of 0.5 to 0.6 N·m (4.4 to 5.3 in·lb), then insert the option (B) into the CN5 connector (J) located on the drive and fasten it using one of the included screws (C).

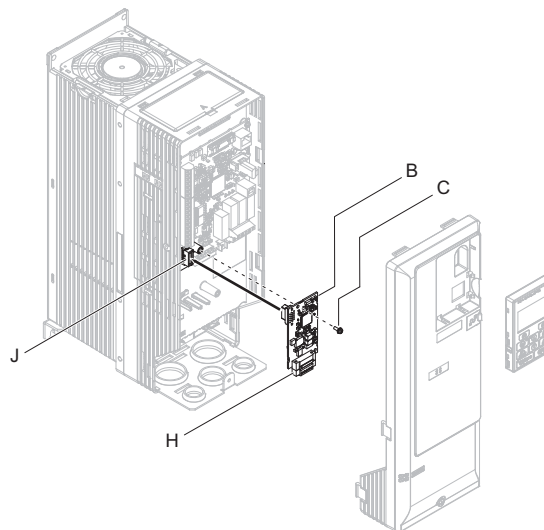

**Figure 13 Insert the Option**

## 5 Installation Procedure

4. Connect the ground wire (G) to the ground terminal (A) using one of the remaining provided screws (C). Connect the other end of the ground wire (G) to the ground terminal and installation hole on the option using the last remaining provided screw (C) and tighten both screws to 0.5 to 0.6 N·m (4.4 to 5.3 in·lb).

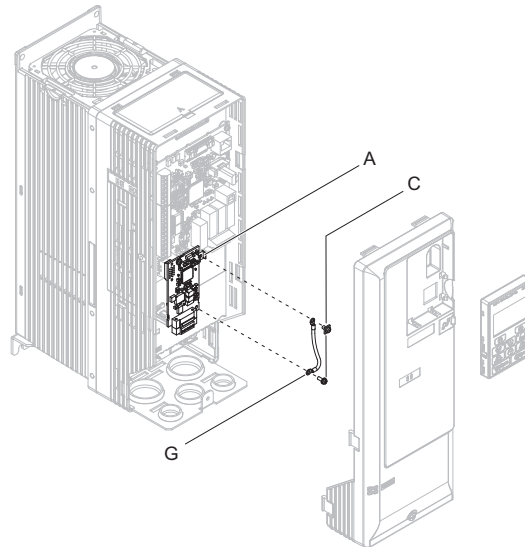
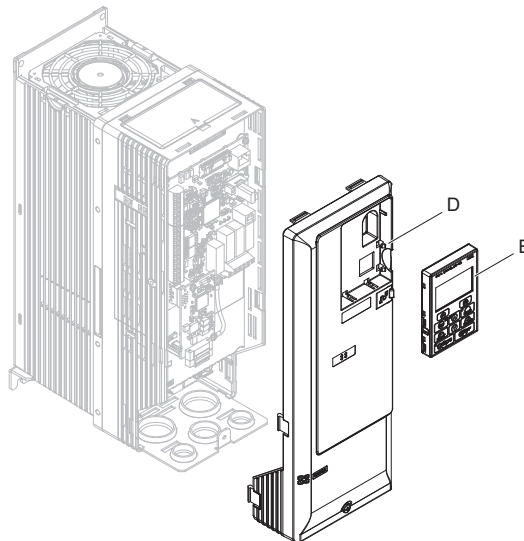

**Figure 14 Connect the Ground Wire**

5. Wire the communication cables.

**Note:** Separate communication cables from main circuit wiring and other electrical lines.

6. Firmly connect the Ethernet communication cable to the option modular connector (CN1). Install Ethernet communications cables apart from main-circuit wiring and other electrical and power lines. Ensure the cable end is firmly connected (see [Figure 22](#)). Refer to [Communication Cable Topology on page 24](#) for details of installing.
7. Reattach the drive front cover (D) and the HOA Keypad (E).



**Figure 15 Replace the Front Cover and HOA Keypad**

**Note:** Take proper precautions when wiring the option so that the front covers will easily fit back onto the drive. Make sure no cables are pinched between the front covers and the drive when replacing the covers.

8. Set drive parameters in [Table 7](#) for correct option performance.

## ■ Procedure C

This section shows the procedure to install and wire the option on a GA700 or GA800 drive.

### Prepare the Drive for the Option

Before you install the option on a YASKAWA AC Drive GA700 or GA800, make sure that the option software version is PRG: 1115 or later.

1. Correctly wire the drive as specified by the manual packaged with the drive.
2. Make sure that the drive functions correctly.

Refer to [Figure 16](#) for an exploded view of the drive with the option and related components for reference in the installation procedure.

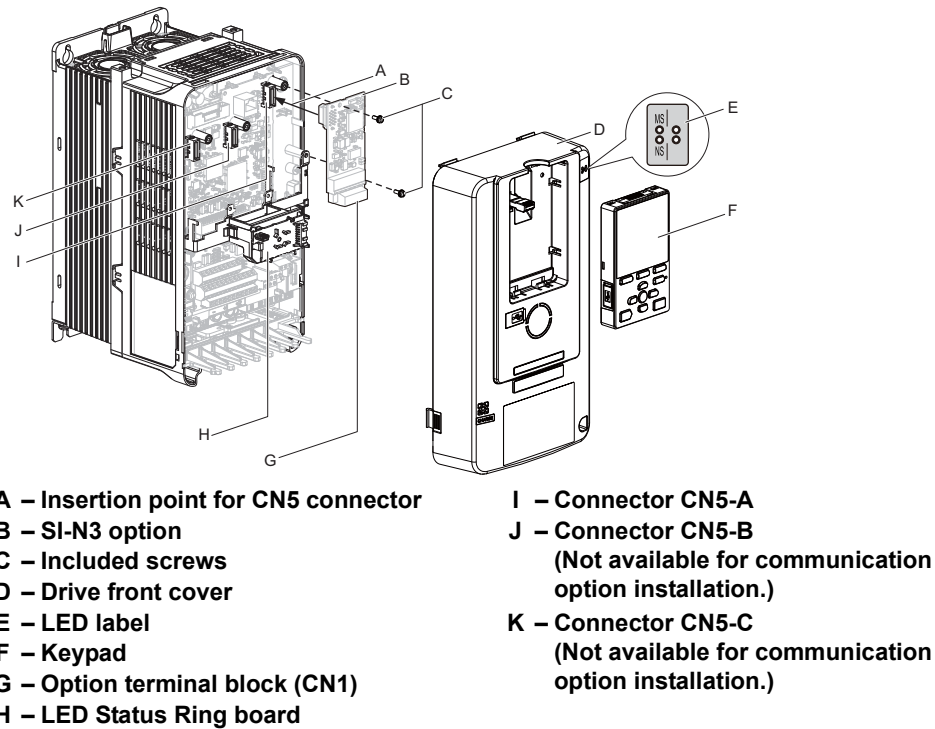

Figure 16 Drive Components with Option

### Install the Option

Remove the front cover of the drive before you install the option. Refer to the drive manual for information about how to remove the front cover. Different drive sizes have different cover removal procedures. You can only install this option into the **CN5-A** connector on the drive control board.

**DANGER! Electrical Shock Hazard.** Do not inspect, connect, or disconnect any wiring while the drive is energized. Failure to comply will cause death or serious injury. Before servicing, disconnect all power to the equipment and wait for at least the time specified on the warning label. The internal capacitor remains charged even after the drive is de-energized. The charge indicator LED will extinguish when the DC bus voltage is below 50 Vdc. When all indicators are OFF, measure for unsafe voltages to confirm the drive is safe.

1. Affix the LED label (E) in the appropriate position on the drive front cover (D).

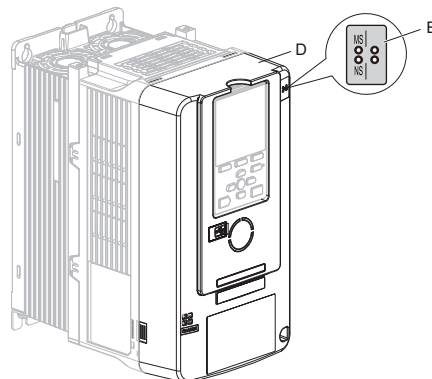
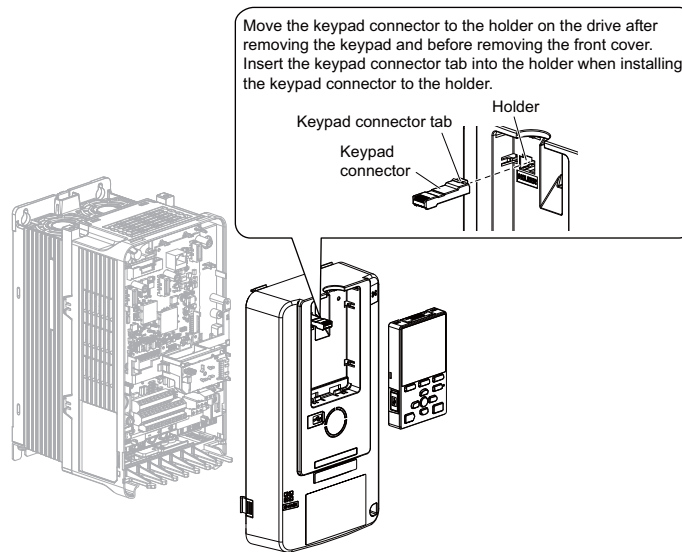

Figure 17 Affix the LED Label

## 5 Installation Procedure

2. Shut off power to the drive, wait the appropriate amount of time for voltage to dissipate, then remove the front cover (D).  
Refer to the manual packaged with the drive for details on cover removal.

**NOTICE:** *Damage to Equipment. Observe proper electrostatic discharge (ESD) procedures when handling the option, drive, and circuit boards. Failure to comply could cause ESD damage to circuitry.*



**Figure 18 Remove the Front Cover and Keypad**

3. Carefully remove the LED Status Ring board (H) and place it on the right side of the drive using the temporary placement holes.  
Refer to the manual packaged with the drive for details on removing the LED Status Ring board.

**NOTICE:** *Do not remove the LED Status Ring board cable connector. Failure to comply could cause erroneous operation and damage the drive.*

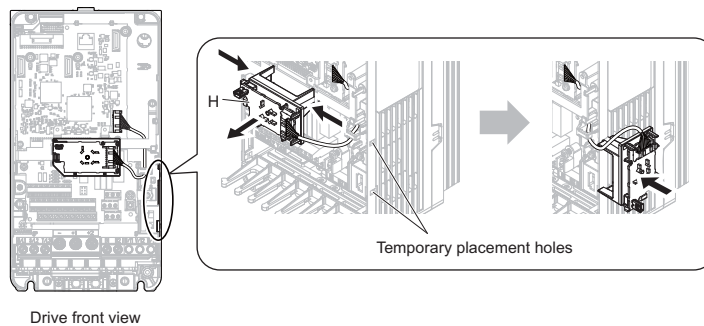

**Figure 19 Remove the LED Status Ring Board**

4. Insert the option card (B) into the CN5-A connector (I) on the drive and fasten it into place using the included screws (C). Tighten both screws to 0.5 to 0.6 N·m (4.4 to 5.3 in·lb).

**Note:** Installing the option card on GA700 and GA800 drives requires only two screws and does not require a ground wire. The option package ships with three screws and a ground wire for installation on other product series. Do not use the ground wire or the extra screw.

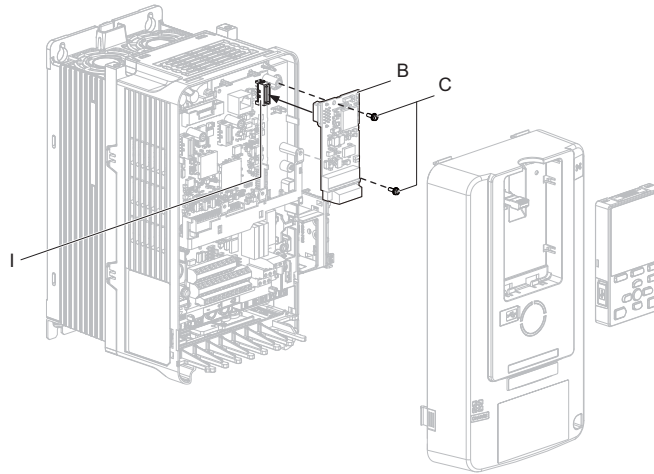

**Figure 20 Insert the Option Card**

5. Firmly connect the DeviceNet communication cable to option terminal block (CN1). Install DeviceNet communications cables apart from main-circuit wiring and other electrical and power lines. Ensure the cable end is firmly connected (see [Figure 22](#)). Refer to [Communication Cable Topology on page 24](#) for details.

**Note:** Maximum transmission distance is 100 m (328 ft). Minimum wiring distance between stations is 0.2 m (7.9 in).

6. Reattach the LED Status Ring board (H). Use the open space provided inside the LED Status Ring board to route option wiring.

**NOTICE:** Do not pinch cables between the front cover or the LED Status Ring board and the drive. Failure to comply could cause erroneous operation.

7. Reattach the drive front cover (D) and the keypad (F).

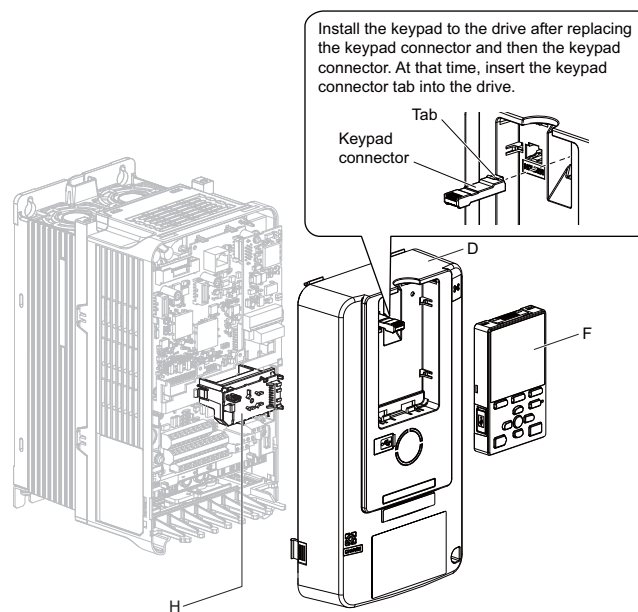

**Figure 21 Replace the Front Cover and Keypad**

8. Set drive parameters in [Table 7](#) for correct option performance.

### ◆ Option Connection Diagram

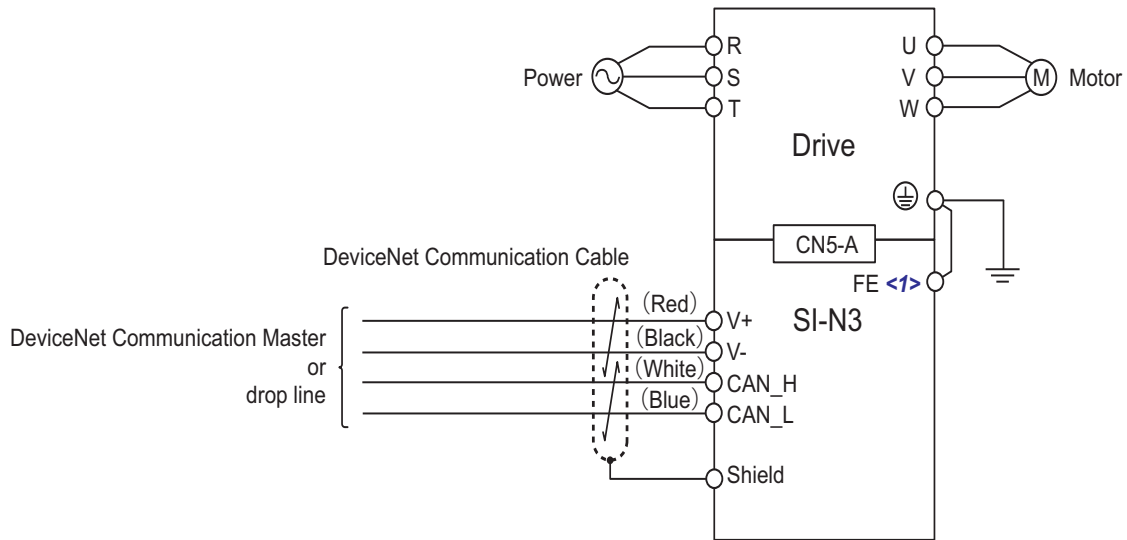

**Figure 22 Option Connection Diagram**

<1> Connect the provided ground wire for installations on 1000-series drives. The ground wire is not necessary for installation on GA700 or GA800 drives.

### ◆ Communication Cable Topology

Refer to the ODVA website ([www.odva.org](http://www.odva.org)) for more information on network cabling.

Refer to *Trunk Line and Drop Line Length on page 100* for details on selecting trunk line and drop line lengths.

Route the option wiring according to the following procedures.

1. Prepare the communication cables as shown in **Figure 23**.

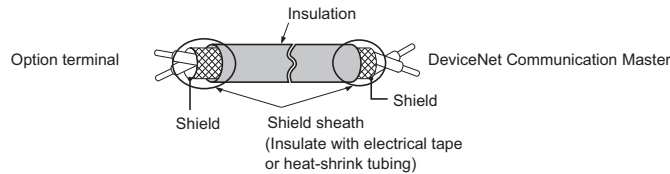

**Figure 23 Prepare Ends of Shielded Cable**

2. Connect the communication cables to the terminal block as shown in **Figure 24**. When attaching the CN1 connector plug on the terminal block to the socket, make sure the screws on the left and right sides of the plug are tightened with a tightening torque of 0.5 to 0.6 (N·m) or 4.4 to 5.43 (in·lb).
3. Take particular caution to ensure that each wire is properly connected and wire insulation is not accidentally pinched into electrical terminals. Trim any frayed wires.

**WARNING! Fire Hazard.** Tighten all terminal screws to the specified tightening torque. Loose or overtightened connections could cause erroneous operation and damage to the terminal block or start a fire and cause death or serious injury.

**NOTICE:** Heat shrink tubing or electrical tape may be required to ensure that cable shielding does not come into contact with other wiring. Insufficient insulation may cause a short circuit that can damage the option or the drive.



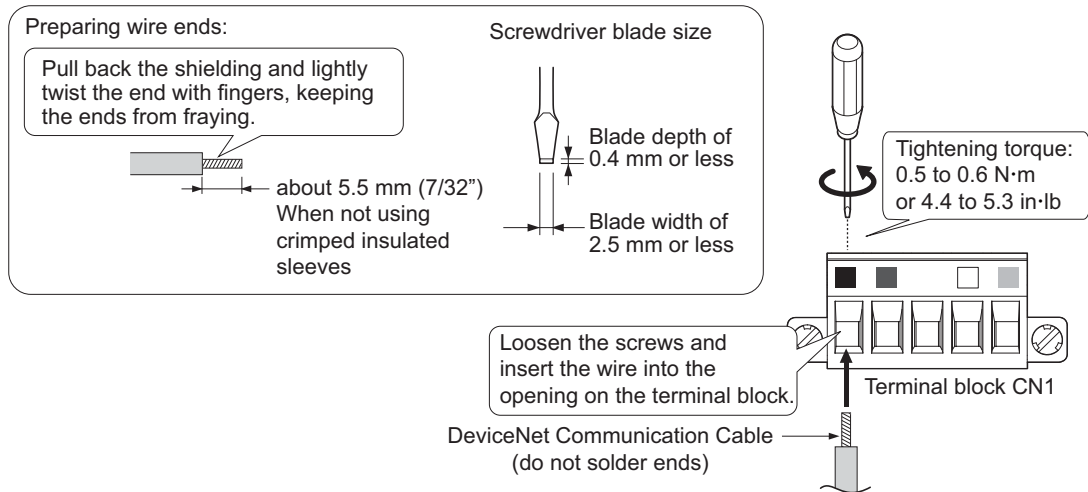

Figure 24 Connect Cable Wiring

## ◆ Termination Resistor Connection

Refer to the ODVA website ([www.odva.org](http://www.odva.org)) for more information on network cabling.

Only connect network termination resistors ( $121 \Omega$ ,  $\pm 1\%$ ,  $1/4$  W) to nodes of the two ends of trunk line. Refer to ODVA specifications for more details on DeviceNet termination.

## ◆ Option MAC ID

### ■ Parameter F6-50, MAC ID Setting 0 to 64

The option MAC ID is set with drive parameter F6-50. MAC ID settings between 0 to 63 are considered valid MAC IDs; setting 64 indicates a network-settable MAC ID.

The option reads the MAC ID value from F6-50 upon power-up and upon a network reset.

## ◆ Option Baud Rate

The option supports standard baud rates of 125 kbps, 250 kbps, and 500 kbps.

Table 6 Parameter F6-51 Baud Rate Setting

Description	Value
125 kbps	0
250 kbps	1
500 kbps	2
Programmable from Network	3
Auto Detect	4

### ■ Auto Baud Rate Sensing (F6-51 = 4)

Setting parameter F6-51 to 4 enables automatic baud rate detection and allows the option to automatically determine the baud rate of the DeviceNet network.

**Note:** Auto baud rate sensing is valid only when there is more than one node physically on the DeviceNet network segment. If the auto baud rate sensing fails to detect the baud rate, the drive keypad will display “bUS” and the option LEDs will be OFF (NS) and solid green (MS).

## ◆ EDS Files

To facilitate network implementation, obtain an EDS file from one of the following websites depending on your region:

U.S.: <http://www.yaskawa.com>

Europe: <http://www.yaskawa.eu.com>

Japan: <http://www.e-mechatronics.com>

Other areas: Check the back cover of these manuals.

For questions, contact Yaskawa or a Yaskawa representative.

## 6 Related Parameters

The parameters in **Table 7** set the drive for operation with the option. Confirm proper setting of all parameters in **Table 7** before starting network communications. Refer to the manual packaged with the drive for details on setting parameters.

**Note:** Hex.: MEMOBUS addresses that you can use to change parameters over network communication are represented in hexadecimal numbers.

**Table 7 Related Parameters**

No. (Hex.)	Name	Description	Values
b1-01 (0180) </>	Reference 1 Source	Selects the input method for frequency reference. 0: Keypad 1: Analog Input 2: Memobus/Modbus Communications 3: Option PCB 4: Pulse Train Input	Default: 1 Range: 0 to 4
b1-02 (0181) </>	Run Command 1 Source	Selects the input method for the Run command. 0: Keypad 1: Digital Input 2: Memobus/Modbus Communications 3: Option PCB	Default: 1 Range: 0 to 3
F6-01 (03A2)	Communication Error Selection	Selects drive response when a bUS error is detected during communications with the option. 0: Ramp to Stop 1: Coast to Stop 2: Fast Stop (Use C1-09) 3: Alarm Only </> 4: Alarm - Run at d1-04 </> </> 5: Alarm - Ramp to Stop </>	Default: 1 Range: 0 to 5 </>
F6-02 (03A3)	Comm External Fault (EF0) Detect	Selects the condition for external fault detection (EF0). 0: Always detected 1: Detection during run only	Default: 0 Range: 0, 1
F6-03 (03A4)	Comm External Fault (EF0) Select	Selects drive response for external fault input (EF0) detection during option communications. 0: Ramp to Stop 1: Coast to Stop 2: Fast Stop (Use C1-09) 3: Alarm Only </>	Default: 1 Range: 0 to 3
F6-06 (03A7) </>	Torque Reference/Limit by Comm	Selects whether to enable or disable the torque reference and torque limit received from the communication option card. 0: Disabled 1: Enabled </>	Default: 0 Range: 0, 1
F6-07 (03A8)	MultiStep Ref Priority Select	0: MultiStep References Disabled 1: MultiStep References Enabled	Default: 0 Range: 0, 1
F6-08 (036A)	Comm Parameter Reset @Initialize	Selects whether communication-related parameters F6-□□ and F7-□□ are set back to original default values when the drive is initialized using parameter A1-03. 0: No Reset - Parameters retained 1: Reset - Back to factory default Note: The setting value is not changed even when F6-08 is set to 1 and the drive is initialized using A1-03.	Default: 0 Range: 0, 1
F6-15 (0B5B) </>	Comm. Option Parameters Reload	Selects whether F6-□□/ F7-□□ communication-related parameters changed are enabled. 0: Reload at Next Power Cycle 1: Reload Now 2: Cancel Reload Request Note: F6-15 is reset to 0 after setting 1 or 2.	Default: 0 Range: 0 to 2
F6-50 (03C1) </> </>	DN MAC Address	Selects the drive MAC address <b>Note:</b> Used in the DeviceNet Object	Default: 0 </10> Min: 0 Max: 64

No. (Hex.)	Name	Description	Values
F6-51 (03C2) <9>	DN Baud Rate	DeviceNet communication speed 0: 125 kbps 1: 250 kbps 2: 500 kbps 3: Adjustable from network 4: Detect automatically <b>Note:</b> Used in the DeviceNet Object	Default: 0 <10> Range: 0 to 4
F6-52 (03C3) <11>	DeviceNet PCA Setting	I/O Polled Consuming Assembly data instance <b>Note:</b> Used in the Connection Object	Default: 21 Min: 0 Max: 255
F6-53 (03C4) <11>	DeviceNet PPA Setting	I/O Polled Producing Assembly data instance <b>Note:</b> Used in the Connection Object	Default: 71 Min: 0 Max: 255
F6-54 (03C5) <9>	DN Idle Flt Det	Determines what the drive should do when communication goes into idle mode. 0: Stop, drive will stop 1: Ignore, drive will continue what it was doing 2: Vendor Specific, drive will use to F6-01 to determine whether it should stop or continue 3: Run Fwd, the drive will run in the forward direction 4: Run Rev, the drive will run in the reverse direction	Default: 0 Range: 0 to 4
F6-55 (03C6)	DN BAUD RATE MEM	Displays the baud rate currently being used for network communications. F6-55 is used only as a monitor. 0: 125 kbps 1: 250 kbps 2: 500 kbps <b>Note:</b> Used in the DeviceNet Object	Default: 0 Range: 0 to 2
F6-56 (03D7)	DeviceNet Speed Scaling	Sets the scaling factor for the Speed Monitor in the DeviceNet Object Class 2A hex <b>Note:</b> Used in the AC/DC Drive Object	Default: 0 Min: -15 Max: 15
F6-57 (03D8)	DeviceNet Current Scaling	Sets the scaling factor for the Output Current Monitor in the DeviceNet Object Class 2A hex <b>Note:</b> Used in the AC/DC Drive Object	Default: 0 Min: -15 Max: 15
F6-58 (03D9)	DeviceNet Torque Scaling	Sets the scaling factor for the Torque Monitor in the DeviceNet Object Class 2A hex <b>Note:</b> Used in the AC/DC Drive Object	Default: 0 Min: -15 Max: 15
F6-59 (03DA)	DeviceNet Power Scaling	Sets the scaling factor for the Power Monitor in the DeviceNet Object Class 2A hex <b>Note:</b> Used in the AC/DC Drive Object	Default: 0 Min: -15 Max: 15
F6-60 (03DB)	DeviceNet Voltage Scaling	Sets the scaling factor for the Voltage Monitor in the DeviceNet Object Class 2A <b>Note:</b> Used in the AC/DC Drive Object	Default: 0 Min: -15 Max: 15
F6-61 (03DC)	DeviceNet Time Scaling	Sets the scaling factor for the Time Monitor in the DeviceNet Object Class 2A hex <b>Note:</b> Used in the AC/DC Drive Object	Default: 0 Min: -15 Max: 15
F6-62 (03DD)	DeviceNet Heartbeat Interval	Sets the heartbeat interval. A setting of 0 disables the heartbeat function. <b>Note:</b> Used in the Identity Object	Default: 0 Min: 0 Max: 10
F6-63 (03DE)	DeviceNet Network MAC ID	Displays the MAC ID assigned to the drive. F6-63 is used only as a monitor. <b>Note:</b> Used in the DeviceNet Object	Default: 0 <10> Min: 0 Max: 63
F6-64 (03DF) <12>	Dynamic Out Assembly 109 Param1 (DOA109 1)	The data in configurable output 1 is written to the MEMOBUS/Modbus address defined by this parameter.	Default: 0x0000 Min: 0x0000 Max: 0xFFFF
F6-65 (03E0) <12>	Dynamic Out Assembly 109 Param2 (DOA109 2)	The data in configurable output 2 is written to the MEMOBUS/Modbus address defined by this parameter.	Default: 0x0000 Min: 0x0000 Max: 0xFFFF
F6-66 (03E1) <12>	Dynamic Out Assembly 109 Param3 (DOA109 3)	The data in configurable output 3 is written to the MEMOBUS/Modbus address defined by this parameter.	Default: 0x0000 Min: 0x0000 Max: 0xFFFF
F6-67 (03E2) <12>	Dynamic Out Assembly 109 Param4 (DOA109 4)	The data in configurable output 4 is written to the MEMOBUS/Modbus address defined by this parameter.	Default: 0x0000 Min: 0x0000 Max: 0xFFFF

## 6 Related Parameters

No. (Hex.)	Name	Description	Values
F6-68 (03E3) <12>	Dynamic In Assembly 159 Param 1 (DIA159 1)	The data in configurable input 1 is read from the MEMOBUS/Modbus address defined by this parameter.	Default: 0x0000 Min: 0x0000 Max: 0xFFFF
F6-69 (03E4) <12>	Dynamic In Assembly 159 Param 2 (DIA159 2)	The data in configurable input 2 is read from the MEMOBUS/Modbus address defined by this parameter.	Default: 0x0000 Min: 0x0000 Max: 0xFFFF
F6-70 (03C7) <12>	Dynamic In Assembly 159 Param 3 (DIA159 3)	The data in configurable input 3 is read from the MEMOBUS/Modbus address defined by this parameter.	Default: 0x0000 Min: 0x0000 Max: 0xFFFF
F6-71 (03C8) <12>	Dynamic In Assembly 159 Param 4 (DIA159 4)	The data in configurable input 4 is read from the MEMOBUS/Modbus address defined by this parameter.	Default: 0x0000 Min: 0x0000 Max: 0xFFFF
U6-97 (07F7)	OPT SPARE 4	Displays option software version	–
U6-98 (07F8)	First Fault	Displays previous faulted status. 0: No fault 1: Option failure 2: PLC in idle state 3: Force fault 1000: Network power loss 1001: Connection timeout 1002: Duplicate MAC ID 1003: Bus-off <b>Note:</b> Used in DeviceNet Option Faults	–
U6-99 (07F9)	Current Fault	Displays the most recent fault status. 0: No fault 1: Option failure 2: PLC in idle state 3: Force fault 1000: Network power loss 1001: Connection timeout 1002: Duplicate MAC ID 1003: Bus-off <b>Note:</b> Used in DeviceNet Option Faults	–

- <1> To start and stop the drive with the DeviceNet master device using serial communications, set b1-02 to 3 or set the Net Control bit in the assemblies or Control Supervisor Object. To control the frequency reference of the drive via the master device, set b1-01 to 3 or set the Net Reference bit in the assemblies or AC/DC object.
- <2> Setting this parameter to 3 or 4 will cause the drive to continue operation after detecting a fault. Take proper measures such as installing an emergency stop switch when using settings 3 or 4.
- <3> Refer to the drive manual to know if settings 4 and 5 are available. Settings 4 and 5 are available in A1000 software versions PRG: 1021 and later.
- <4> The setting range for 1000-Series drives is different for different software versions. Refer to the instruction manual of a specific drive for more information.
- <5> Control method availability of this parameter depends on product series.
- 1000-Series Drives: Parameter is available in CLV, AOLV/PM, and CLV/PM.  
In AOLV/PM, this value is read as the Torque Limit.
  - GA700, GA800 Drives: Parameter is available in OLV, CLV, AOLV, AOLV/PM, CLV/PM, and EZOLV.  
In OLV and EZOLV, this value is read as the Torque Limit.
- <6> The setting specifies that network communications provide the torque reference or torque limit. The motor may not rotate if the PLC does not supply a torque reference or torque limit.
- <7> Supported on PRG: 1115. Not available on 1000-series drives.
- <8> All MAC addresses must be unique.
- <9> Cycle power for setting changes to take effect.
- <10> The default setting depends on region code. Refer to [Table 8](#) on page 28 for more information.
- <11> Setting unavailable values will initialize Polled Consuming Assembly (PCA) and Polled Producing Assembly (PPA).
- <12> Available in the option software versions PRG: 1111 and later.

**Table 8 Regional Default Setting**

No.	Name	Default by Region Code Example: CIMR-V□ or GA70□	
		Code: A, B, C, D, K, T (Japan, China, Europe, India, Korea, Asia)	Code: U (The Americas)
F6-50	DeviceNet MAC Address	0	64
F6-51	DeviceNet Baud Rate	0	4
F6-63	DeviceNet Network MAC ID	0	63

## 7 Configuring DeviceNet Messaging

This section provides information on the methods used to control the drive on DeviceNet.

### ◆ Drive Configuration on DeviceNet

#### ■ Polled Configuration

Configure the drive DeviceNet polled connection before receiving commands from a master device. The two parameters that must be configured are:

- F6-52: Polled Consuming Assembly (PCA)

**Note:** Output assembly consumed by the drive.

- F6-53: Polled Producing Assembly (PPA)

**Note:** Input assembly produced by the drive.

The default connection paths for the option are set for Extended Speed Control.

The PCA and PPA parameters can be accessed by two methods:

- A software configuration tool (not supplied), and Yaskawa Electronic Data Sheet (EDS)

**Note:** The PCA and PPA parameters can be accessed from the “DN: Polled Config” parameter group.

- A software configuration tool (not supplied), via a DeviceNet message path, such as Extended Speed Control

**Note:** Use DeviceNet Connection Object to change the PCA or PPA if required by the application (Class 5, Instance 1, Attributes 14 and 16)

One of each PCA and PPA assembly from the following table must be selected to configure the drive for polled operation.

Refer to PCA on page 31 and PPA on page 54 for more information about each assembly.

**Table 9 Supported Polled Assemblies (PCA and PPA)**

Assembly Number (decimal)	Description	Type	Bytes
20	<i>Basic Speed Control Output - 20 (0x14)</i>	PCA	4
21	<i>Extended Speed Control Output - 21 (0x15)</i> (Default Setting)	PCA	4
22	<i>Speed and Torque Control Output - 22 (0x16)</i>	PCA	6
23	<i>Extended Speed and Torque Control Output - 23 (0x17)</i>	PCA	6
70	<i>Basic Speed Control Input - 70 (0x46)</i>	PPA	4
71	<i>Extended Speed Control Input - 71 (0x47)</i> (Default Setting)	PPA	4
72	<i>Speed and Torque Control Input - 72 (0x48)</i>	PPA	6
73	<i>Extended Speed and Torque Control Input - 73 (0x49)</i>	PPA	6
100	<i>MEMOBUS/Modbus Message Command (Vendor Specific Yaskawa Electric (YE) Assy) - 100 (0x64)</i>	PCA	5
101	<i>Standard Control (Vendor Specific Yaskawa Electric (YE) Assy) - 101 (0x65)</i>	PCA	8
102	<i>Accel/Decel Time (Vendor Specific Yaskawa Electric (YE) Assy) - 102 (0x66)</i>	PCA	8
103 <1>	<i>3-Wire Control1 (Vendor Specific Yaskawa Electric (YE) Assy) - 103 (0x67)</i>	PCA	4
104 <1>	<i>3-Wire Control Status1 (Vendor Specific Yaskawa Electric (YE) Assy) - 104 (0x68)</i>	PPA	4
105	<i>Enhanced Speed Control, Dynamic (Vendor Specific Yaskawa Electric (YE) Assy) - 105 (0x69)</i>	PCA	8
106	<i>Enhanced Control (Vendor Specific Yaskawa Electric (YE) Assy) - 106 (0x6A)</i>	PCA	8
107	<i>Standard DI/DO Control (Vendor Specific Yaskawa Electric (YE) Assy) - 107 (0x6B)</i>	PCA	8
108	<i>Enhanced Torque Control, Dynamic (Vendor Specific Yaskawa Electric (YE) Assy) - 108 (0x6C)</i>	PCA	8
109 <2>	<i>Dynamic Output Assembly (Vendor Specific Yaskawa Electric (YE) Assy) - 109 (0x6D)</i>	PCA	8
110 <3>	<i>3-Wire Control2 (Vendor Specific Yaskawa Electric (YE) Assy) - 110 (0x6E)</i>	PCA	4
120	<i>Speed Command 1 (Vendor Specific Yaskawa Electric (YE) Assy) - 120 (0x78)</i>	PCA	4
121	<i>Torque Command 1 (Vendor Specific Yaskawa Electric (YE) Assy) - 121 (0x79)</i>	PCA	4
122	<i>Speed Command 2 (Vendor Specific Yaskawa Electric (YE) Assy) - 122 (0x7A)</i>	PCA	6

## 7 Configuring DeviceNet Messaging

Assembly Number (decimal)	Description	Type	Bytes
123	<i>Torque Command 2 (Vendor Specific Yaskawa Electric (YE) Assy) - 123 (0x7B)</i>	PCA	6
124	<i>Speed Dynamic Assy (Vendor Specific Yaskawa Electric (YE) Assy) - 124 (0x7C)</i>	PCA	8
125	<i>Torque Dynamic Assy (Vendor Specific Yaskawa Electric (YE) Assy) - 125 (0x7D)</i>	PCA	8
126	<i>Speed/Torque Assy (Vendor Specific Yaskawa Electric (YE) Assy) - 126 (0x7E)</i>	PCA	8
130	<i>Speed Status (Vendor Specific Yaskawa Electric (YE) Assy) - 130 (0x82)</i>	PPA	4
131	<i>Current Status (Vendor Specific Yaskawa Electric (YE) Assy) - 131 (0x83)</i>	PPA	4
132	<i>Current &amp; Speed Status (Vendor Specific Yaskawa Electric (YE) Assy) - 132 (0x84)</i>	PPA	6
134	<i>Speed Status Dynamic Assy (Vendor Specific Yaskawa Electric (YE) Assy) - 134 (0x86)</i>	PPA	8
135	<i>Current Status Dynamic Assy (Vendor Specific Yaskawa Electric (YE) Assy) - 135 (0x87)</i>	PPA	8
136	<i>Torque and Speed Status (Vendor Specific Yaskawa Electric (YE) Assy) - 136 (0x88)</i>	PPA	8
150	<i>MEMOBUS/Modbus Message Reply (Vendor Specific Yaskawa Electric (YE) Assy) - 150 (0x96)</i>	PPA	5
151	<i>Standard Status 1 (Vendor Specific Yaskawa Electric (YE) Assy) - 151 (0x97)</i>	PPA	8
152	<i>Standard Status 2 (Vendor Specific Yaskawa Electric (YE) Assy) -152 (0x98)</i>	PPA	8
155	<i>Enhanced Speed Status, Dynamic (Vendor Specific Yaskawa Electric (YE) Assy) - 155 (0x9B)</i>	PPA	8
156	<i>Enhanced Control Status (Vendor Specific Yaskawa Electric (YE) Assy) -156 (0x9C)</i>	PPA	8
157	<i>Standard DI/DO Status (Vendor Specific Yaskawa Electric (YE) Assy) - 157 (0x9D)</i>	PPA	8
158	<i>Enhanced Torque Status, Dynamic (Vendor Specific Yaskawa Electric (YE) Assy) - 158 (0x9E)</i>	PPA	8
159 <1>	<i>Dynamic Input Assembly (Vendor Specific Yaskawa Electric (YE) Assy) - 159 (0x9F)</i>	PPA	8
160 <2>	<i>3-Wire Control Status2 (Vendor Specific Yaskawa Electric (YE) Assy) - 160 (0xA0)</i>	PPA	4
199 <3>	<i>Change of State Response (Vendor Specific Yaskawa Electric (YE) Assy) - 199 (0xC7)</i>	PPA	8

<1> Available in option software versions PRG: 1107 and later.

<2> Available in option software versions PRG: 1111 and later.

<3> Available in option software versions PRG: 1114 and later.

### ◆ Additional Support for Setting Connection Path Types

The option also supports symbolic encoding to support application tools and development tools that do not handle explicit message fragmentation. Symbolic encoding requires only a 3-byte long message where logical encoding requires 11 bytes.

The option has a third method of setting polled consumed and produced connection paths. Class 5, Instance 2, Attributes (100, 101) allow setting connection path with a single byte. For instance, to set the consumed connection path to 100, write 100 (0x64) to Attribute 101. See appendix C of "The CIP Networks Library, Volume 1" for more information on CIP segments

## 8 Output Assemblies (Drive Consumes)

The convention in this manual is from the PLC perspective. As such, an assembly is called an “Output Assembly” when outputted from the PLC and received by this node. An “Input Assembly” is outputted from this node and read by the PLC. This section details “Output Assemblies” that are “Consumed” by the drive.

### ◆ Basic Speed Control Output - 20 (0x14)

Output Instance	Byte	Bit 7	Bit 6	Bit 5	Bit 4	Bit 3	Bit 2	Bit 1	Bit 0
20	0	-	-	-	-	-	Fault Reset	-	Run Fwd
	1	-							
	2	Speed Reference (Low Byte)							
	3	Speed Reference (High Byte)							

Name	Description
Run Fwd	Forward Run Command 0: Stop 1: Forward Run
Fault Reset	Fault Reset 0: No Fault Reset 1: Fault Reset
Speed Reference	Speed Command Sets drive speed reference Speed reference data: Frequency reference / 2 <sup>SS</sup> (SS: Speed scale) Setting range: 0 to 0xFFFF For example, when setting a reference of 1024 with a speed scale of 2 Speed reference data = 1024 / 2 <sup>2</sup> = 256 = 0x0100 Unit depends on o1-03.

### ◆ Extended Speed Control Output - 21 (0x15)

Output Instance	Byte	Bit 7	Bit 6	Bit 5	Bit 4	Bit 3	Bit 2	Bit 1	Bit 0
21	0	-	Net Ref	Net Ctrl	-	-	Fault Reset	Run Rev	Run Fwd
	1	-							
	2	Speed Reference (Low Byte)							
	3	Speed Reference (High Byte)							

Name	Description
Run Fwd	Forward Run Command 0: Stop 1: Forward Run
Run Rev	Reverse Run Command 0: Stop 1: Reverse Run
Fault Reset	Fault Reset 0: No Fault Reset 1: Fault Reset
NetCtrl	Run command from Network 0: Depends on b1-02 1: Enables the run command from network
NetRef	Speed reference from Network 0: Depends on b1-01 1: Enables the speed reference from network



## 8 Output Assemblies (Drive Consumes)

Name	Description
Speed Reference	Speed Command Sets drive speed reference Speed reference data: Frequency reference / $2^{SS}$ (SS: Speed scale) Setting range: 0 to 0xFFFF For example, when setting a reference of 1024 with a speed scale of 2 Speed reference data = $1024 / 2^2 = 256 = 0x0100$ Unit depends on o1-03.

### ◆ Speed and Torque Control Output - 22 (0x16)

Output Instance	Byte	Bit 7	Bit 6	Bit 5	Bit 4	Bit 3	Bit 2	Bit 1	Bit 0
22	0	–	–	–	–	–	Fault Reset	–	Run Fwd
	1	–							
	2	Speed Reference (Low Byte)							
	3	Speed Reference (High Byte)							
	4	Torque Reference/Torque Limit (Low Byte)							
	5	Torque Reference/Torque Limit (High Byte)							

Name	Description
Run Fwd	Forward Run Command 0: Stop 1: Forward Run
Fault Reset	Fault Reset 0: No Fault Reset 1: Fault Reset
Speed Reference	Speed Command Sets drive speed reference Speed reference data: Frequency reference / $2^{SS}$ (SS: Speed scale) Setting range: 0 to 0xFFFF For example, when setting a reference of 1024 with a speed scale of 2 Speed reference data = $1024 / 2^2 = 256 = 0x0100$ Unit depends on o1-03.
Torque Reference/Torque Limit	Torque Reference/Torque Limit Sets the torque reference and torque limit in units of 0.1%. Sets the torque reference when using torque control (d5-01 = 1). Sets the torque limit when using speed control (d5-01 = 0). The torque reference and torque limit are disabled when F6-06 = 0.

### ◆ Extended Speed and Torque Control Output - 23 (0x17)

Output Instance	Byte	Bit 7	Bit 6	Bit 5	Bit 4	Bit 3	Bit 2	Bit 1	Bit 0
23	0	–	Net Ref	Net Ctrl	–	–	Fault Reset	Run Rev	Run Fwd
	1	–							
	2	Speed Reference (Low Byte)							
	3	Speed Reference (High Byte)							
	4	Torque Reference/Torque Limit (Low Byte)							
	5	Torque Reference/Torque Limit (High Byte)							

Name	Description
Run Fwd	Forward Run Command 0: Stop 1: Forward Run
Run Rev	Reverse Run Command 0: Stop 1: Reverse Run



Name	Description
Fault Reset	Fault Reset 0: No Fault Reset 1: Fault Reset
NetCtrl	Run command from Network 0: Depends on b1-02 1: Enables the run command from network
NetRef	Speed reference from Network 0: Depends on b1-01 1: Enables the speed reference from network
Speed Reference	Speed Command Sets drive speed reference Speed reference data: Frequency reference $\times 2^{SS}$ (SS: Speed scale) Setting range: 0 to 0xFFFF For example, when setting a reference of 1024 with a speed scale of 2 Speed reference data = $1024 \times 2^2 = 4096 = 0x1000$ Unit depends on o1-03.
Torque Reference/Torque Limit	Torque Reference/Torque Limit Sets the torque reference and torque limit in units of 0.1%. Sets the torque reference when using torque control (d5-01 = 1). Sets the torque limit when using speed control (d5-01 = 0). The torque reference and torque limit are disabled when F6-06 = 0.

### ◆ MEMOBUS/Modbus Message Command (Vendor Specific Yaskawa Electric (YE) Assy) - 100 (0x64)

Output Instance	Byte	Bit 7	Bit 6	Bit 5	Bit 4	Bit 3	Bit 2	Bit 1	Bit 0
100	0	Function Code							
	1	Register Number (High Byte)							
	2	Register Number (Low Byte)							
	3	Register Data (High Byte)							
	4	Register Data (Low Byte)							

**Note:** This is a paired assembly (100/150).

Name	Description
Function Code	MEMOBUS/Modbus Function Code <i>Refer to Function Code Decode Table on page 33.</i>
Register Number	MEMOBUS/Modbus Register Number
Register Data	MEMOBUS/Modbus Register Data

**Table 10 Function Code Decode Table**

Function Code	MEMOBUS/Modbus Function
0x00	No Operation
0x03	Read Register
0x10	Write Register

**Note:** Refer to the MEMOBUS/Modbus Data Table in the drive Technical Manual for a list of monitor data using the MEMOBUS/Modbus message area.

◆ Standard Control (Vendor Specific Yaskawa Electric (YE) Assy) - 101 (0x65)

Output Instance	Byte	Bit 7	Bit 6	Bit 5	Bit 4	Bit 3	Bit 2	Bit 1	Bit 0	
101	0	Multi-Function Input 8	Multi-Function Input 7	Multi-Function Input 6	Multi-Function Input 5	Multi-Function Input 4	Multi-Function Input 3	Run Rev	Run Fwd	
	1	<ul style="list-style-type: none"> <li>YASKAWA AC Drive 1000-Series Multi-Function Photocoupler 2</li> <li>YASKAWA AC Drive GA700, GA800 Multi-Function Digital Output 3</li> </ul>	<ul style="list-style-type: none"> <li>YASKAWA AC Drive 1000-Series Multi-Function Photocoupler 1</li> <li>YASKAWA AC Drive GA700, GA800 Multi-Function Digital Output 2</li> </ul>	<ul style="list-style-type: none"> <li>YASKAWA AC Drive 1000-Series Multi-Function Digital Output</li> <li>YASKAWA AC Drive GA700, GA800 Multi-Function Digital Output 1</li> </ul>	-	-	-	Fault Reset	External Fault	
	2	Speed Reference (Low Byte)								
	3	Speed Reference (High Byte)								
	4	Torque Reference/Torque Limit (Low Byte)								
	5	Torque Reference/Torque Limit (High Byte)								
	6	Torque Compensation (Low Byte)								
	7	Torque Compensation (High Byte)								

Name	Description
Run Fwd	Forward Run Command 0: Stop 1: Forward Run
Run Rev	Reverse Run Command 0: Stop 1: Reverse Run
Multi-Function Input 3	Terminal S3 Function Input 0: Terminal S3 Function (H1-03) OFF 1: Terminal S3 Function (H1-03) ON
Multi-Function Input 4	Terminal S4 Function Input 0: Terminal S4 Function (H1-04) OFF 1: Terminal S4 Function (H1-04) ON
Multi-Function Input 5	Terminal S5 Function Input 0: Terminal S5 Function (H1-05) OFF 1: Terminal S5 Function (H1-05) ON
Multi-Function Input 6	Terminal S6 Function Input 0: Terminal S6 Function (H1-06) OFF 1: Terminal S6 Function (H1-06) ON
Multi-Function Input 7	Terminal S7 Function Input 0: Terminal S7 Function (H1-07) OFF 1: Terminal S7 Function (H1-07) ON
Multi-Function Input 8	Terminal S8 Function Input 0: Terminal S8 Function (H1-08) OFF 1: Terminal S8 Function (H1-08) ON
External Fault	External Fault EF0 0: No External Fault (EF0) 1: External Fault (EF0)
Fault Reset	Fault Reset 0: No Fault Reset 1: Fault Reset
<ul style="list-style-type: none"> <li>YASKAWA AC Drive 1000-Series Multi-Function Digital Output</li> <li>YASKAWA AC Drive GA700, GA800 Multi-Function Digital Output 1</li> </ul>	Terminal M1/M2 0: M1/M2 OFF 1: M1/M2 ON This function is enabled only when H2-01 is set to F.

Name	Description
<ul style="list-style-type: none"> <li>YASKAWA AC Drive 1000-Series Multi-Function Photocoupler 1</li> <li>YASKAWA AC Drive GA700, GA800 Multi-Function Digital Output 2</li> </ul>	<ul style="list-style-type: none"> <li>YASKAWA AC Drive 1000-Series Terminal P1 &lt;1&gt;</li> <li>0: P1 OFF</li> <li>1: P1 ON</li> <li>YASKAWA AC Drive GA700, GA800 Terminal M3/M4</li> <li>0: M3/M4 OFF</li> <li>1: M3/M4 ON</li> </ul> <p>This function is enabled only when H2-02 is set to F.</p>
<ul style="list-style-type: none"> <li>YASKAWA AC Drive 1000-Series Multi-Function Photocoupler 2</li> <li>YASKAWA AC Drive GA700, GA800 Multi-Function Digital Output 3</li> </ul>	<ul style="list-style-type: none"> <li>YASKAWA AC Drive 1000-Series Terminal P2 &lt;1&gt;</li> <li>0: P2 OFF</li> <li>1: P2 ON</li> <li>YASKAWA AC Drive GA700, GA800 Terminal P1 &lt;1&gt;</li> <li>0: P1 OFF</li> <li>1: P1 ON</li> </ul> <p>This function is enabled only when H2-03 is set to F.</p>
Multi-Function Digital Output4 <2>	<ul style="list-style-type: none"> <li>Terminal P2 &lt;1&gt;</li> <li>0: P2 OFF</li> <li>1: P2 ON</li> </ul> <p>This function is enabled only when H2-04 is set to F.</p>
Speed Reference	<p>Speed Command</p> <p>Sets drive speed reference</p> <p>Unit depends on o1-03.</p> <p>Unit is not affected by Speed Scale SS.</p>
Torque Reference/Torque Limit	<p>Torque Reference/Torque Limit</p> <p>Sets the torque reference and torque limit in units of 0.1%.</p> <p>Sets the torque reference when using torque control (d5-01 = 1).</p> <p>Sets the torque limit when using speed control (d5-01 = 0).</p> <p>The torque reference and torque limit are disabled when F6-06 = 0.</p>
Torque Compensation	<p>Sets the amount of torque compensation.</p> <p>Set in units of 0.1%.</p>

<1> Terminals will differ depending on the model of the drive. Refer to *Terminals that Change depending on the Model of the Drive on page 53* for information on terminals.

<2> Multi-function digital output 4 is not available for the YASKAWA AC Drive 1000-Series.

**◆ Accel/Decel Time (Vendor Specific Yaskawa Electric (YE) Assy) - 102 (0x66)**

Output Instance	Byte	Bit 7	Bit 6	Bit 5	Bit 4	Bit 3	Bit 2	Bit 1	Bit 0	
102	0	Multi-Function Input 8	Multi-Function Input 7	Multi-Function Input 6	Multi-Function Input 5	Multi-Function Input 4	Multi-Function Input 3	Run Rev	Run Fwd	
	1	<ul style="list-style-type: none"> <li>YASKAWA AC Drive 1000-Series Multi-Function Photocoupler 2</li> <li>YASKAWA AC Drive GA700, GA800 Multi-Function Digital Output 3</li> </ul>	<ul style="list-style-type: none"> <li>YASKAWA AC Drive 1000-Series Multi-Function Photocoupler 1</li> <li>YASKAWA AC Drive GA700, GA800 Multi-Function Digital Output 2</li> </ul>	<ul style="list-style-type: none"> <li>YASKAWA AC Drive 1000-Series Multi-Function Digital Output</li> <li>YASKAWA AC Drive GA700, GA800 Multi-Function Digital Output 1</li> </ul>	-	-	-	Fault Reset	External Fault	
	2	Speed Reference (Low Byte)								
	3	Speed Reference (High Byte)								
	4	Acceleration Time 1 (Low Byte)								
	5	Acceleration Time 1 (High Byte)								
	6	Deceleration Time 1 (Low Byte)								
	7	Deceleration Time 1 (High Byte)								

## 8 Output Assemblies (Drive Consumes)

Parameter	Data
Run Fwd	Forward Run Command 0: Stop 1: Forward Run
Run Rev	Reverse Run Command 0: Stop 1: Reverse Run
Multi-Function Input 3	Terminal S3 Function Input 0: Terminal S3 Function (H1-03) OFF 1: Terminal S3 Function (H1-03) ON
Multi-Function Input 4	Terminal S4 Function Input 0: Terminal S4 Function (H1-04) OFF 1: Terminal S4 Function (H1-04) ON
Multi-Function Input 5	Terminal S5 Function Input 0: Terminal S5 Function (H1-05) OFF 1: Terminal S5 Function (H1-05) ON
Multi-Function Input 6	Terminal S6 Function Input 0: Terminal S6 Function (H1-06) OFF 1: Terminal S6 Function (H1-06) ON
Multi-Function Input 7	Terminal S7 Function Input 0: Terminal S7 Function (H1-07) OFF 1: Terminal S7 Function (H1-07) ON
Multi-Function Input 8	Terminal S8 Function Input 0: Terminal S8 Function (H1-08) OFF 1: Terminal S8 Function (H1-08) ON
External Fault	External Fault EF0 0: No External Fault (EF0) 1: External Fault (EF0)
Fault Reset	Fault Reset 0: No Fault Reset 1: Fault Reset
<ul style="list-style-type: none"> <li>YASKAWA AC Drive 1000-Series Multi-Function Digital Output</li> <li>YASKAWA AC Drive GA700, GA800 Multi-Function Digital Output 1</li> </ul>	Terminal M1/M2 0: M1/M2 OFF 1: M1/M2 ON This function is enabled only when H2-01 is set to F.
<ul style="list-style-type: none"> <li>YASKAWA AC Drive 1000-Series Multi-Function Photocoupler 1</li> <li>YASKAWA AC Drive GA700, GA800 Multi-Function Digital Output 2</li> </ul>	<ul style="list-style-type: none"> <li>YASKAWA AC Drive 1000-Series Terminal P1 &lt;/&gt; 0: P1 OFF 1: P1 ON</li> <li>YASKAWA AC Drive GA700, GA800 Terminal M3/M4 0: M3/M4 OFF 1: M3/M4 ON</li> </ul> This function is enabled only when H2-02 is set to F.
<ul style="list-style-type: none"> <li>YASKAWA AC Drive 1000-Series Multi-Function Photocoupler 2</li> <li>YASKAWA AC Drive GA700, GA800 Multi-Function Digital Output 3</li> </ul>	<ul style="list-style-type: none"> <li>YASKAWA AC Drive 1000-Series Terminal P2 &lt;/&gt; 0: P2 OFF 1: P2 ON</li> <li>YASKAWA AC Drive GA700, GA800 Terminal P1 &lt;/&gt; 0: P1 OFF 1: P1 ON</li> </ul> This function is enabled only when H2-03 is set to F.
Multi-Function Digital Output4 <2>	Terminal P2 </> 0: P2 OFF 1: P2 ON This function is enabled only when H2-04 is set to F.
Speed Reference	Speed Command Sets drive speed reference Unit depends on o1-03. Unit is not affected by Speed Scale SS.

Parameter	Data
Acceleration Time 1	Acceleration Time 1 (C1-01) Unit depends on C1-10. Unit is not affected by Time Scale TS.
Deceleration Time 1	Deceleration Time 1 (C1-02) Unit depends on C1-10. Unit is not affected by Time Scale TS.

<1> Terminals will differ depending on the model of the drive. Refer to *Terminals that Change depending on the Model of the Drive on page 53* for information on terminals.

<2> Multi-function digital output 4 is not available for the YASKAWA AC Drive 1000-Series.

### ◆ 3-Wire Control1 (Vendor Specific Yaskawa Electric (YE) Assy) - 103 (0x67)

**Note:** Available in the option software versions PRG: 1107 and later.

Output Instance	Byte	Bit 7	Bit 6	Bit 5	Bit 4	Bit 3	Bit 2	Bit 1	Bit 0	
103	0	–	–	Direction		Fault Reset	–	Start	Stop	
	1	–	Reference Selection			–	–	–	–	
	2	Speed Reference (Low Byte)								
	3	Speed Reference (High Byte)								

Name	Description
Stop	Stop Command 0: No command 1: Stop command
Start	Stop Command 0: No command 1: Stop command
Fault Reset	Fault Reset 0: No Fault Reset 1: Fault Reset
Direction	Direction Command Refer to <a href="#">Table 11</a> .
Reference Selection	Reference Selection Command Refer to <a href="#">Table 12</a> .
Speed Reference	Speed Command Sets drive speed reference. Unit depends on o1-03 parameter setting. Unit is not affected by Speed Scale SS.

**Table 11 Direction Command**

Behavior	Bit 5	Bit 4
No Change	0	0
Forward	0	1
Reverse	1	0
No Change	1	1

**Table 12 Reference Selection Command**

Speed Reference Source Selection	Bit 6	Bit 5	Bit 4
No command Speed Reference (Bytes 2, 3) not used	0	0	0
Analog Input A2	0	0	1
From Network (Bytes 2, 3)	0	1	0
Preset 3 (value in parameter d1-03)	0	1	1
Preset 4 (value in parameter d1-04)	1	0	0
Preset 5 (value in parameter d1-05)	1	0	1
Preset 6 (value in parameter d1-06)	1	1	0
Preset 7 (value in parameter d1-07)	1	1	1

◆ Enhanced Speed Control, Dynamic (Vendor Specific Yaskawa Electric (YE) Assy) - 105 (0x69)

Output Instance	Byte	Bit 7	Bit 6	Bit 5	Bit 4	Bit 3	Bit 2	Bit 1	Bit 0	
105	0	Multi-Function Input 8	Multi-Function Input 7	Multi-Function Input 6	Multi-Function Input 5	Multi-Function Input 4	Multi-Function Input 3	Run Rev	Run Fwd	
	1	<ul style="list-style-type: none"> <li>• YASKAWA AC Drive 1000-Series Multi-Function Photocoupler 2</li> <li>• YASKAWA AC Drive GA700, GA800 Multi-Function Digital Output 3</li> </ul>	<ul style="list-style-type: none"> <li>• YASKAWA AC Drive 1000-Series Multi-Function Photocoupler 1</li> <li>• YASKAWA AC Drive GA700, GA800 Multi-Function Digital Output 2</li> </ul>	<ul style="list-style-type: none"> <li>• YASKAWA AC Drive 1000-Series Multi-Function Digital Output</li> <li>• YASKAWA AC Drive GA700, GA800 Multi-Function Digital Output 1</li> </ul>	-	Function Code High Bit	Function Code Low Bit	Fault Reset	External Fault	
	2	Speed Reference (Low Byte)								
	3	Speed Reference (High Byte)								
	4	Register Number (Low Byte)								
	5	Register Number (High Byte)								
	6	Register Data (Low Byte)								
	7	Register Data (High Byte)								

Name	Description
Run Fwd	Forward Run Command 0: Stop 1: Forward Run
Run Rev	Reverse Run Command 0: Stop 1: Reverse Run
Multi-Function Input 3	Terminal S3 Function Input 0: Terminal S3 Function (H1-03) OFF 1: Terminal S3 Function (H1-03) ON
Multi-Function Input 4	Terminal S4 Function Input 0: Terminal S4 Function (H1-04) OFF 1: Terminal S4 Function (H1-04) ON
Multi-Function Input 5	Terminal S5 Function Input 0: Terminal S5 Function (H1-05) OFF 1: Terminal S5 Function (H1-05) ON
Multi-Function Input 6	Terminal S6 Function Input 0: Terminal S6 Function (H1-06) OFF 1: Terminal S6 Function (H1-06) ON
Multi-Function Input 7	Terminal S7 Function Input 0: Terminal S7 Function (H1-07) OFF 1: Terminal S7 Function (H1-07) ON
Multi-Function Input 8	Terminal S8 Function Input 0: Terminal S8 Function (H1-08) OFF 1: Terminal S8 Function (H1-08) ON
External Fault	External Fault EF0 0: No External Fault (EF0) 1: External Fault (EF0)
Fault Reset	Fault Reset 0: No Fault Reset 1: Fault Reset
Function Code	MEMOBUS/Modbus Function Code <i>Refer to Function Code Decode Table on page 39.</i>

Name	Description
<ul style="list-style-type: none"> <li>• YASKAWA AC Drive 1000-Series Multi-Function Digital Output</li> <li>• YASKAWA AC Drive GA700, GA800 Multi-Function Digital Output 1</li> </ul>	Terminal M1/M2 0: M1/M2 OFF 1: M1/M2 ON This function is enabled only when H2-01 is set to F.
<ul style="list-style-type: none"> <li>• YASKAWA AC Drive 1000-Series Multi-Function Photocoupler 1</li> <li>• YASKAWA AC Drive GA700, GA800 Multi-Function Digital Output 2</li> </ul>	<ul style="list-style-type: none"> <li>• YASKAWA AC Drive 1000-Series Terminal P1 &lt;1&gt;</li> <li>0: P1 OFF 1: P1 ON</li> <li>• YASKAWA AC Drive GA700, GA800 Terminal M3/M4</li> <li>0: M3/M4 OFF 1: M3/M4 ON</li> <li>This function is enabled only when H2-02 is set to F.</li> </ul>
<ul style="list-style-type: none"> <li>• YASKAWA AC Drive 1000-Series Multi-Function Photocoupler 2</li> <li>• YASKAWA AC Drive GA700, GA800 Multi-Function Digital Output 3</li> </ul>	<ul style="list-style-type: none"> <li>• YASKAWA AC Drive 1000-Series Terminal P2 &lt;1&gt;</li> <li>0: P2 OFF 1: P2 ON</li> <li>• YASKAWA AC Drive GA700, GA800 Terminal P1 &lt;1&gt;</li> <li>0: P1 OFF 1: P1 ON</li> <li>This function is enabled only when H2-03 is set to F.</li> </ul>
Multi-Function Digital Output4 <2>	Terminal P2 <1> 0: P2 OFF 1: P2 ON This function is enabled only when H2-04 is set to F.
Speed Reference	Speed Command Sets drive speed reference Unit depends on o1-03. Unit is not affected by Speed Scale SS.
Register Number	MEMOBUS/Modbus Register Number <3>
Register Data	MEMOBUS/Modbus Register Data

<1> Terminals will differ depending on the model of the drive. Refer to [Terminals that Change depending on the Model of the Drive on page 53](#) for information on terminals.

<2> Multi-function digital output 4 is not available for the YASKAWA AC Drive 1000-Series.

<3> Register numbers 0x0001, 0x0002, and 0x0009 are disabled.

**Note:** This is a paired assembly (105/155).

**Table 13 Function Code Decode Table**

Function Code High Byte - Low Byte	MEMOBUS/Modbus Function
0 0	No Operation
1 0	Read Register
0 1	Write Register
1 1	No Operation

**Note:** Refer to the MEMOBUS/Modbus Data Table in the drive Technical Manual for a list of monitor data using the MEMOBUS/Modbus message area.

◆ Enhanced Control (Vendor Specific Yaskawa Electric (YE) Assy) - 106 (0x6A)

Output Instance	Byte	Bit 7	Bit 6	Bit 5	Bit 4	Bit 3	Bit 2	Bit 1	Bit 0
106	0	Multi-Function Input 8	Multi-Function Input 7	Multi-Function Input 6	Multi-Function Input 5	Multi-Function Input 4	Multi-Function Input 3	Run Rev	Run Fwd
	1	<ul style="list-style-type: none"> <li>YASKAWA AC Drive 1000-Series Multi-Function Photocoupler 2</li> <li>YASKAWA AC Drive GA700, GA800 Multi-Function Digital Output 3</li> </ul>	<ul style="list-style-type: none"> <li>YASKAWA AC Drive 1000-Series Multi-Function Photocoupler 1</li> <li>YASKAWA AC Drive GA700, GA800 Multi-Function Digital Output 2</li> </ul>	<ul style="list-style-type: none"> <li>YASKAWA AC Drive 1000-Series Multi-Function Digital Output</li> <li>YASKAWA AC Drive GA700, GA800 Multi-Function Digital Output 1</li> </ul>	-	-	-	Fault Reset	External Fault
	2	Speed Reference (Low Byte)							
	3	Speed Reference (High Byte)							
	4	-							
	5	-							
	6	-							
	7	-							

Name	Description
Run Fwd	Forward Run Command 0: Stop 1: Forward Run
Run Rev	Reverse Run Command 0: Stop 1: Reverse Run
Multi-Function Input 3	Terminal S3 Function Input 0: Terminal S3 Function (H1-03) OFF 1: Terminal S3 Function (H1-03) ON
Multi-Function Input 4	Terminal S4 Function Input 0: Terminal S4 Function (H1-04) OFF 1: Terminal S4 Function (H1-04) ON
Multi-Function Input 5	Terminal S5 Function Input 0: Terminal S5 Function (H1-05) OFF 1: Terminal S5 Function (H1-05) ON
Multi-Function Input 6	Terminal S6 Function Input 0: Terminal S6 Function (H1-06) OFF 1: Terminal S6 Function (H1-06) ON
Multi-Function Input 7	Terminal S7 Function Input 0: Terminal S7 Function (H1-07) OFF 1: Terminal S7 Function (H1-07) ON
Multi-Function Input 8	Terminal S8 Function Input 0: Terminal S8 Function (H1-08) OFF 1: Terminal S8 Function (H1-08) ON
External Fault	External Fault EF0 0: No External Fault (EF0) 1: External Fault (EF0)
Fault Reset	Fault Reset 0: No Fault Reset 1: Fault Reset
<ul style="list-style-type: none"> <li>YASKAWA AC Drive 1000-Series Multi-Function Digital Output</li> <li>YASKAWA AC Drive GA700, GA800 Multi-Function Digital Output 1</li> </ul>	Terminal M1/M2 0: M1/M2 OFF 1: M1/M2 ON This function is enabled only when H2-01 is set to F.



Name	Description
<ul style="list-style-type: none"> <li>YASKAWA AC Drive 1000-Series Multi-Function Photocoupler 1</li> <li>YASKAWA AC Drive GA700, GA800 Multi-Function Digital Output 2</li> </ul>	<ul style="list-style-type: none"> <li>YASKAWA AC Drive 1000-Series Terminal P1 &lt;1&gt;</li> <li>0: P1 OFF</li> <li>1: P1 ON</li> <li>YASKAWA AC Drive GA700, GA800 Terminal M3/M4</li> <li>0: M3/M4 OFF</li> <li>1: M3/M4 ON</li> </ul> <p>This function is enabled only when H2-02 is set to F.</p>
<ul style="list-style-type: none"> <li>YASKAWA AC Drive 1000-Series Multi-Function Photocoupler 2</li> <li>YASKAWA AC Drive GA700, GA800 Multi-Function Digital Output 3</li> </ul>	<ul style="list-style-type: none"> <li>YASKAWA AC Drive 1000-Series Terminal P2 &lt;1&gt;</li> <li>0: P2 OFF</li> <li>1: P2 ON</li> <li>YASKAWA AC Drive GA700, GA800 Terminal P1 &lt;1&gt;</li> <li>0: P1 OFF</li> <li>1: P1 ON</li> </ul> <p>This function is enabled only when H2-03 is set to F.</p>
Multi-Function Digital Output4 <2>	<ul style="list-style-type: none"> <li>Terminal P2 &lt;1&gt;</li> <li>0: P2 OFF</li> <li>1: P2 ON</li> </ul> <p>This function is enabled only when H2-04 is set to F.</p>
Speed Reference	<ul style="list-style-type: none"> <li>Speed Command</li> <li>Sets drive speed reference</li> <li>Unit depends on o1-03.</li> <li>Unit is not affected by Speed Scale SS.</li> </ul>

<1> Terminals will differ depending on the model of the drive. Refer to [Terminals that Change depending on the Model of the Drive on page 53](#) for information on terminals.

<2> Multi-function digital output 4 is not available for the YASKAWA AC Drive 1000-Series.

**◆ Standard DI/DO Control (Vendor Specific Yaskawa Electric (YE) Assy) - 107 (0x6B)**

Output Instance	Byte	Bit 7	Bit 6	Bit 5	Bit 4	Bit 3	Bit 2	Bit 1	Bit 0	
107	0	Multi-Function Input 8	Multi-Function Input 7	Multi-Function Input 6	Multi-Function Input 5	Multi-Function Input 4	Multi-Function Input 3	Run Rev	Run Fwd	
	1	-	-	-	-	-	-	Fault Reset	External Fault	
	2	-	-	<ul style="list-style-type: none"> <li>YASKAWA AC Drive 1000-Series Multi-Function Photocoupler 2</li> <li>YASKAWA AC Drive GA700, GA800 Multi-Function Digital Output 3</li> </ul>	<ul style="list-style-type: none"> <li>YASKAWA AC Drive 1000-Series Multi-Function Photocoupler 1</li> <li>YASKAWA AC Drive GA700, GA800 Multi-Function Digital Output 2</li> </ul>	<ul style="list-style-type: none"> <li>YASKAWA AC Drive 1000-Series Multi-Function Digital Output 1</li> </ul>	-	-	-	
	3	-	-	-	-	-	-	-	-	
	4	Analog Output 1 (Low Byte)								
	5	Analog Output 1 (High Byte)								
	6	Speed Reference (Low Byte)								
	7	Speed Reference (High Byte)								

## 8 Output Assemblies (Drive Consumes)

Name	Description
Run Fwd	Forward Run Command 0: Stop 1: Forward Run
Run Rev	Reverse Run Command 0: Stop 1: Reverse Run
Multi-Function Input 3	Terminal S3 Function Input 0: Terminal S3 Function (H1-03) OFF 1: Terminal S3 Function (H1-03) ON
Multi-Function Input 4	Terminal S4 Function Input 0: Terminal S4 Function (H1-04) OFF 1: Terminal S4 Function (H1-04) ON
Multi-Function Input 5	Terminal S5 Function Input 0: Terminal S5 Function (H1-05) OFF 1: Terminal S5 Function (H1-05) ON
Multi-Function Input 6	Terminal S6 Function Input 0: Terminal S6 Function (H1-06) OFF 1: Terminal S6 Function (H1-06) ON
Multi-Function Input 7	Terminal S7 Function Input 0: Terminal S7 Function (H1-07) OFF 1: Terminal S7 Function (H1-07) ON
Multi-Function Input 8	Terminal S8 Function Input 0: Terminal S8 Function (H1-08) OFF 1: Terminal S8 Function (H1-08) ON
External Fault	External Fault EF0 0: No External Fault (EF0) 1: External Fault (EF0)
Fault Reset	Fault Reset 0: No Fault Reset 1: Fault Reset
<ul style="list-style-type: none"> <li>YASKAWA AC Drive 1000-Series Multi-Function Digital Output</li> <li>YASKAWA AC Drive GA700, GA800 Multi-Function Digital Output 1</li> </ul>	Terminal M1/M2 0: M1/M2 OFF 1: M1/M2 ON This function is enabled only when H2-01 is set to F.
<ul style="list-style-type: none"> <li>YASKAWA AC Drive 1000-Series Multi-Function Photocoupler 1</li> <li>YASKAWA AC Drive GA700, GA800 Multi-Function Digital Output 2</li> </ul>	<ul style="list-style-type: none"> <li>YASKAWA AC Drive 1000-Series Terminal P1 &lt;/&gt; 0: P1 OFF 1: P1 ON</li> <li>YASKAWA AC Drive GA700, GA800 Terminal M3/M4 0: M3/M4 OFF 1: M3/M4 ON</li> </ul> This function is enabled only when H2-02 is set to F.
<ul style="list-style-type: none"> <li>YASKAWA AC Drive 1000-Series Multi-Function Photocoupler 2</li> <li>YASKAWA AC Drive GA700, GA800 Multi-Function Digital Output 3</li> </ul>	<ul style="list-style-type: none"> <li>YASKAWA AC Drive 1000-Series Terminal P2 &lt;/&gt; 0: P2 OFF 1: P2 ON</li> <li>YASKAWA AC Drive GA700, GA800 Terminal P1 &lt;/&gt; 0: P1 OFF 1: P1 ON</li> </ul> This function is enabled only when H2-03 is set to F.
Multi-Function Digital Output4 <2>	Terminal P2 </> 0: P2 OFF 1: P2 ON This function is enabled only when H2-04 is set to F.
Analog Output 1	Analog Output FM This function is enabled only when H4-01 is set to 000.

Name	Description
Speed Reference	Speed Command Sets drive speed reference Unit depends on o1-03. Unit is not affected by Speed Scale SS.

<1> Terminals will differ depending on the model of the drive. Refer to *Terminals that Change depending on the Model of the Drive on page 53* for information on terminals.

<2> Multi-function digital output 4 is not available for the YASKAWA AC Drive 1000-Series.

**◆ Enhanced Torque Control, Dynamic (Vendor Specific Yaskawa Electric (YE) Assy) - 108 (0x6C)**

Output Instance	Byte	Bit 7	Bit 6	Bit 5	Bit 4	Bit 3	Bit 2	Bit 1	Bit 0	
108	0	Multi-Function Input 8	Multi-Function Input 7	Multi-Function Input 6	Multi-Function Input 5	Multi-Function Input 4	Multi-Function Input 3	Run Rev	Run Fwd	
	1	<ul style="list-style-type: none"> <li>• YASKAWA AC Drive 1000-Series Multi-Function Photocoupler 2</li> <li>• YASKAWA AC Drive GA700, GA800 Multi-Function Digital Output 3</li> </ul>	<ul style="list-style-type: none"> <li>• YASKAWA AC Drive 1000-Series Multi-Function Photocoupler 1</li> <li>• YASKAWA AC Drive GA700, GA800 Multi-Function Digital Output 2</li> </ul>	<ul style="list-style-type: none"> <li>• YASKAWA AC Drive 1000-Series Multi-Function Digital Output</li> <li>• YASKAWA AC Drive GA700, GA800 Multi-Function Digital Output 1</li> </ul>	-	Function Code High Bit	Function Code Low Bit	Fault Reset	External Fault	
	2	Torque Reference/Torque Limit (Low Byte)								
	3	Torque Reference/Torque Limit (High Byte)								
	4	Register Number (Low Byte)								
	5	Register Number (High Byte)								
	6	Register Data (Low Byte)								
	7	Register Data (High Byte)								

Name	Description
Run Fwd	Forward Run Command 0: Stop 1: Forward Run
Run Rev	Reverse Run Command 0: Stop 1: Reverse Run
Multi-Function Input 3	Terminal S3 Function Input 0: Terminal S3 Function (H1-03) OFF 1: Terminal S3 Function (H1-03) ON
Multi-Function Input 4	Terminal S4 Function Input 0: Terminal S4 Function (H1-04) OFF 1: Terminal S4 Function (H1-04) ON
Multi-Function Input 5	Terminal S5 Function Input 0: Terminal S5 Function (H1-05) OFF 1: Terminal S5 Function (H1-05) ON
Multi-Function Input 6	Terminal S6 Function Input 0: Terminal S6 Function (H1-06) OFF 1: Terminal S6 Function (H1-06) ON
Multi-Function Input 7	Terminal S7 Function Input 0: Terminal S7 Function (H1-07) OFF 1: Terminal S7 Function (H1-07) ON
Multi-Function Input 8	Terminal S8 Function Input 0: Terminal S8 Function (H1-08) OFF 1: Terminal S8 Function (H1-08) ON
External Fault	External Fault EF0 0: No External Fault (EF0) 1: External Fault (EF0)

## 8 Output Assemblies (Drive Consumes)

Name	Description
Fault Reset	Fault Reset 0: No Fault Reset 1: Fault Reset
Function Code	MEMOBUS/Modbus Function Code <i>Refer to Function Code Decode Table on page 39.</i>
<ul style="list-style-type: none"> <li>YASKAWA AC Drive 1000-Series Multi-Function Digital Output</li> <li>YASKAWA AC Drive GA700, GA800 Multi-Function Digital Output 1</li> </ul>	Terminal M1/M2 0: M1/M2 OFF 1: M1/M2 ON This function is enabled only when H2-01 is set to F.
<ul style="list-style-type: none"> <li>YASKAWA AC Drive 1000-Series Multi-Function Photocoupler 1</li> <li>YASKAWA AC Drive GA700, GA800 Multi-Function Digital Output 2</li> </ul>	<ul style="list-style-type: none"> <li>YASKAWA AC Drive 1000-Series Terminal P1 &lt;1&gt;</li> <li>0: P1 OFF 1: P1 ON</li> <li>YASKAWA AC Drive GA700, GA800 Terminal M3/M4</li> <li>0: M3/M4 OFF 1: M3/M4 ON</li> </ul> This function is enabled only when H2-02 is set to F.
<ul style="list-style-type: none"> <li>YASKAWA AC Drive 1000-Series Multi-Function Photocoupler 2</li> <li>YASKAWA AC Drive GA700, GA800 Multi-Function Digital Output 3</li> </ul>	<ul style="list-style-type: none"> <li>YASKAWA AC Drive 1000-Series Terminal P2 &lt;1&gt;</li> <li>0: P2 OFF 1: P2 ON</li> <li>YASKAWA AC Drive GA700, GA800 Terminal P1 &lt;1&gt;</li> <li>0: P1 OFF 1: P1 ON</li> </ul> This function is enabled only when H2-03 is set to F.
Multi-Function Digital Output4 <2>	Terminal P2 <1> 0: P2 OFF 1: P2 ON This function is enabled only when H2-04 is set to F.
Torque Reference/Torque Limit	Torque Reference/Torque Limit Sets the torque reference and torque limit in units of 0.1%. Sets the torque reference when using torque control (d5-01 = 1). Sets the torque limit when using speed control (d5-01 = 0). The torque reference and torque limit are disabled when F6-06 = 0.
Register Number	MEMOBUS/Modbus Register Number <3>
Register Data	MEMOBUS/Modbus Register Data

<1> Terminals will differ depending on the model of the drive. Refer to *Terminals that Change depending on the Model of the Drive on page 53* for information on terminals.

<2> Multi-function digital output 4 is not available for the YASKAWA AC Drive 1000-Series.

<3> Register numbers 0x0001 and 0x0009 are disabled.

**Note:** 1. This is a paired assembly (108/158).

2. Refer to the MEMOBUS/Modbus Data Table in the drive Technical Manual for a list of monitor data using the MEMOBUS/Modbus message area.

### ◆ Dynamic Output Assembly (Vendor Specific Yaskawa Electric (YE) Assy) - 109 (0x6D)

This assembly is dynamic and can be configured as to what parameters are used.

**Note:** Available in the option software versions PRG: 1111 and later.

Output Instance	Byte	Bit 7
109	0	Configurable Output 1 (Low Byte)
	1	Configurable Output 1 (High Byte)
	2	Configurable Output 2 (Low Byte)
	3	Configurable Output 2 (High Byte)
	4	Configurable Output 3 (Low Byte)
	5	Configurable Output 3 (High Byte)
	6	Configurable Output 4 (Low Byte)
	7	Configurable Output 4 (High Byte)

Name	Description
Configurable Output 1	Data to be written to the MEMOBUS/Modbus address defined in parameter F6-64. If F6-64 = 0, then MEMOBUS/Modbus address 0x0001 (Drive Command) is used.
Configurable Output 2	Data to be written to the MEMOBUS/Modbus address defined in parameter F6-65. If F6-65 = 0, then MEMOBUS/Modbus address 0x0002 (Frequency Reference) is used.
Configurable Output 3	Data to be written to the MEMOBUS/Modbus address defined in parameter F6-66. If F6-66 = 0, then MEMOBUS/Modbus address 0x0004 (Torque Reference) is used.
Configurable Output 4	Data to be written to the MEMOBUS/Modbus address defined in parameter F6-67. If F6-67 = 0, then MEMOBUS/Modbus address 0x0009 (Digital Outputs) is used.

### ◆ 3-Wire Control2 (Vendor Specific Yaskawa Electric (YE) Assy) - 110 (0x6E)

Output Instance	Byte	Definition
110	0	Control Word (Low Byte)
	1	Control Word (High Byte)
	2	Speed Reference (0.1 Hz) (Low Byte)
	3	Speed Reference (0.1 Hz) (High Byte)

Bits	Description
0	0->1 Start Drive
1	0->1 Stop drive
2	0->1 Start Jog
3	Fault Reset
4-5	Set drive direction 00: No change 01: Forward 10: Reverse 11: No change
6	Digital Output 2 if H2-02 is set to 0x0F
7	Digital Output 3 if H2-03 is set to 0x0F
8-9	Changes Accel/Decel rate if reference is from option card. This will set Digital Input 6 in the drive if its function value is set to 7. 00: No command 01: Accel1/Decel1 (C1-01/C1-02) 10: Accel2/Decel2 (C1-03/C1-04) 11: No command
10-11	Reserved

## 8 Output Assemblies (Drive Consumes)

Bits	Description
12-14	<u>Reference source</u> 000: Stay at last reference 001: B1-01 010: D1-01 011: Use network set value 100: D1-02 101: D1-03 110: D1-04 111: D1-05
15	Digital Output 1 if H2-01 is set to 0x0F

### ◆ Speed Command 1 (Vendor Specific Yaskawa Electric (YE) Assy) - 120 (0x78)

Output Instance	Byte	Bit 7	Bit 6	Bit 5	Bit 4	Bit 3	Bit 2	Bit 1	Bit 0
120	0	Multi-Function Input 8	Multi-Function Input 7	Multi-Function Input 6	Multi-Function Input 5	Multi-Function Input 4	Multi-Function Input 3	Run Rev	Run Fwd
	1	–	–	–	–	–	–	Fault Reset	External Fault
	2	Speed Reference (Low Byte)							
	3	Speed Reference (High Byte)							

Name	Description
Run Fwd	Forward Run Command 0: Stop 1: Forward Run
Run Rev	Reverse Run Command 0: Stop 1: Reverse Run
Multi-Function Input 3	Terminal S3 Function Input 0: Terminal S3 Function (H1-03) OFF 1: Terminal S3 Function (H1-03) ON
Multi-Function Input 4	Terminal S4 Function Input 0: Terminal S4 Function (H1-04) OFF 1: Terminal S4 Function (H1-04) ON
Multi-Function Input 5	Terminal S5 Function Input 0: Terminal S5 Function (H1-05) OFF 1: Terminal S5 Function (H1-05) ON
Multi-Function Input 6	Terminal S6 Function Input 0: Terminal S6 Function (H1-06) OFF 1: Terminal S6 Function (H1-06) ON
Multi-Function Input 7	Terminal S7 Function Input 0: Terminal S7 Function (H1-07) OFF 1: Terminal S7 Function (H1-07) ON
Multi-Function Input 8	Terminal S8 Function Input 0: Terminal S8 Function (H1-08) OFF 1: Terminal S8 Function (H1-08) ON
External Fault	External Fault EF0 0: No External Fault (EF0) 1: External Fault (EF0)
Fault Reset	Fault Reset 0: No Fault Reset 1: Fault Reset
Speed Reference	Speed Command Sets drive speed reference Unit depends on o1-03. Unit is not affected by Speed Scale SS.

### ◆ Torque Command 1 (Vendor Specific Yaskawa Electric (YE) Assy) - 121 (0x79)

Output Instance	Byte	Bit 7	Bit 6	Bit 5	Bit 4	Bit 3	Bit 2	Bit 1	Bit 0
121	0	Multi-Function Input 8	Multi-Function Input 7	Multi-Function Input 6	Multi-Function Input 5	Multi-Function Input 4	Multi-Function Input 3	Run Rev	Run Fwd
	1	–	–	–	–	–	–	Fault Reset	External Fault
	2	Torque Reference/Torque Limit (Low Byte)							
	3	Torque Reference/Torque Limit (High Byte)							

Name	Description
Run Fwd	Forward Run Command 0: Stop 1: Forward Run
Run Rev	Reverse Run Command 0: Stop 1: Reverse Run
Multi-Function Input 3	Terminal S3 Function Input 0: Terminal S3 Function (H1-03) OFF 1: Terminal S3 Function (H1-03) ON
Multi-Function Input 4	Terminal S4 Function Input 0: Terminal S4 Function (H1-04) OFF 1: Terminal S4 Function (H1-04) ON
Multi-Function Input 5	Terminal S5 Function Input 0: Terminal S5 Function (H1-05) OFF 1: Terminal S5 Function (H1-05) ON
Multi-Function Input 6	Terminal S6 Function Input 0: Terminal S6 Function (H1-06) OFF 1: Terminal S6 Function (H1-06) ON
Multi-Function Input 7	Terminal S7 Function Input 0: Terminal S7 Function (H1-07) OFF 1: Terminal S7 Function (H1-07) ON
Multi-Function Input 8	Terminal S8 Function Input 0: Terminal S8 Function (H1-08) OFF 1: Terminal S8 Function (H1-08) ON
External Fault	External Fault EF0 0: No External Fault (EF0) 1: External Fault (EF0)
Fault Reset	Fault Reset 0: No Fault Reset 1: Fault Reset
Torque Reference/Torque Limit	Torque Reference/Torque Limit Sets the torque reference and torque limit in units of 0.1%. Sets the torque reference when using torque control (d5-01 = 1). Sets the torque limit when using speed control (d5-01 = 0). The torque reference and torque limit are disabled when F6-06 = 0.

### ◆ Speed Command 2 (Vendor Specific Yaskawa Electric (YE) Assy) - 122 (0x7A)

Output Instance	Byte	Bit 7	Bit 6	Bit 5	Bit 4	Bit 3	Bit 2	Bit 1	Bit 0
122	0	Multi-Function Input 8	Multi-Function Input 7	Multi-Function Input 6	Multi-Function Input 5	Multi-Function Input 4	Multi-Function Input 3	Run Rev	Run Fwd
	1	–	–	–	–	–	–	Fault Reset	External Fault
	2	Speed Reference (Low Byte)							
	3	Speed Reference (High Byte)							
	4	NetRef							
	5	NetCtrl							

## 8 Output Assemblies (Drive Consumes)

Name	Description
Run Fwd	Forward Run Command 0: Stop 1: Forward Run
Run Rev	Reverse Run Command 0: Stop 1: Reverse Run
Multi-Function Input 3	Terminal S3 Function Input 0: Terminal S3 Function (H1-03) OFF 1: Terminal S3 Function (H1-03) ON
Multi-Function Input 4	Terminal S4 Function Input 0: Terminal S4 Function (H1-04) OFF 1: Terminal S4 Function (H1-04) ON
Multi-Function Input 5	Terminal S5 Function Input 0: Terminal S5 Function (H1-05) OFF 1: Terminal S5 Function (H1-05) ON
Multi-Function Input 6	Terminal S6 Function Input 0: Terminal S6 Function (H1-06) OFF 1: Terminal S6 Function (H1-06) ON
Multi-Function Input 7	Terminal S7 Function Input 0: Terminal S7 Function (H1-07) OFF 1: Terminal S7 Function (H1-07) ON
Multi-Function Input 8	Terminal S8 Function Input 0: Terminal S8 Function (H1-08) OFF 1: Terminal S8 Function (H1-08) ON
External Fault	External Fault EF0 0: No External Fault (EF0) 1: External Fault (EF0)
Fault Reset	Fault Reset 0: No Fault Reset 1: Fault Reset
Speed Reference	Speed Command Sets drive speed reference Unit depends on o1-03. Unit is not affected by Speed Scale SS.
NetRef	Speed reference form Network 0x00: Depends on b1-01 0x01: Enables the speed reference from network
NetCtrl	Run command form Network 0x00: Depends on b1-02 0x01: Enables the run command from network

### ◆ Torque Command 2 (Vendor Specific Yaskawa Electric (YE) Assy) - 123 (0x7B)

Output Instance	Byte	Bit 7	Bit 6	Bit 5	Bit 4	Bit 3	Bit 2	Bit 1	Bit 0
123	0	Multi-Function Input 8	Multi-Function Input 7	Multi-Function Input 6	Multi-Function Input 5	Multi-Function Input 4	Multi-Function Input 3	Run Rev	Run Fwd
	1	–	–	–	–	–	–	Fault Reset	External Fault
	2	Torque Reference/Torque Limit (Low Byte)							
	3	Torque Reference/Torque Limit (High Byte)							
	4	NetRef							
	5	NetCtrl							

Name	Description
Run Fwd	Forward Run Command 0: Stop 1: Forward Run



Name	Description
Run Rev	Reverse Run Command 0: Stop 1: Reverse Run
Multi-Function Input 3	Terminal S3 Function Input 0: Terminal S3 Function (H1-03) OFF 1: Terminal S3 Function (H1-03) ON
Multi-Function Input 4	Terminal S4 Function Input 0: Terminal S4 Function (H1-04) OFF 1: Terminal S4 Function (H1-04) ON
Multi-Function Input 5	Terminal S5 Function Input 0: Terminal S5 Function (H1-05) OFF 1: Terminal S5 Function (H1-05) ON
Multi-Function Input 6	Terminal S6 Function Input 0: Terminal S6 Function (H1-06) OFF 1: Terminal S6 Function (H1-06) ON
Multi-Function Input 7	Terminal S7 Function Input 0: Terminal S7 Function (H1-07) OFF 1: Terminal S7 Function (H1-07) ON
Multi-Function Input 8	Terminal S8 Function Input 0: Terminal S8 Function (H1-08) OFF 1: Terminal S8 Function (H1-08) ON
External Fault	External Fault EF0 0: No External Fault (EF0) 1: External Fault (EF0)
Fault Reset	Fault Reset 0: No Fault Reset 1: Fault Reset
Torque Reference/Torque Limit	Torque Reference/Torque Limit Sets the torque reference and torque limit in units of 0.1%. Sets the torque reference when using torque control (d5-01 = 1). Sets the torque limit when using speed control (d5-01 = 0). The torque reference and torque limit are disabled when F6-06 = 0.
NetRef	Speed reference from Network 0x00: Depends on b1-01 0x01: Enables the speed reference from network
NetCtrl	Run command from Network 0x00: Depends on b1-02 0x01: Enables the run command from network

◆ Speed Dynamic Assy (Vendor Specific Yaskawa Electric (YE) Assy) - 124 (0x7C)

Output Instance	Byte	Bit 7	Bit 6	Bit 5	Bit 4	Bit 3	Bit 2	Bit 1	Bit 0
124	0	Multi-Function Input 8	Multi-Function Input 7	Multi-Function Input 6	Multi-Function Input 5	Multi-Function Input 4	Multi-Function Input 3	Run Rev	Run Fwd
	1	Service Code							
	2	Class							
	3	Attribute							
	4	Data (Low Byte)							
	5	Data (High Byte)							
	6	Speed Reference (Low Byte)							
	7	Speed Reference (High Byte)							

Name	Description
Run Fwd	Forward Run Command 0: Stop 1: Forward Run
Run Rev	Reverse Run Command 0: Stop 1: Reverse Run

## 8 Output Assemblies (Drive Consumes)

Name	Description
Multi-Function Input 3	Terminal S3 Function Input 0: Terminal S3 Function (H1-03) OFF 1: Terminal S3 Function (H1-03) ON
Multi-Function Input 4	Terminal S4 Function Input 0: Terminal S4 Function (H1-04) OFF 1: Terminal S4 Function (H1-04) ON
Multi-Function Input 5	Terminal S5 Function Input 0: Terminal S5 Function (H1-05) OFF 1: Terminal S5 Function (H1-05) ON
Multi-Function Input 6	Terminal S6 Function Input 0: Terminal S6 Function (H1-06) OFF 1: Terminal S6 Function (H1-06) ON
Multi-Function Input 7	Terminal S7 Function Input 0: Terminal S7 Function (H1-07) OFF 1: Terminal S7 Function (H1-07) ON
Multi-Function Input 8	Terminal S8 Function Input 0: Terminal S8 Function (H1-08) OFF 1: Terminal S8 Function (H1-08) ON
Service Code	Service Code <i>Refer to Service Code Decode Table on page 50.</i>
Class	Class Valid Classes are Control Supervisor Object (41) and AC/DC Object (42). Instance will always be 1.
Attribute	Attribute
Data	Data
Speed Reference	Speed Command Sets drive speed reference Unit depends on o1-03. Unit is not affected by Speed Scale SS.

**Note:** This is a paired assembly (124/134).

**Table 14 Service Code Decode Table**

Service Code	Function
0x00	No Operation
0x0E	Get Attribute Single
0x10	Set Attribute Single

### ◆ Torque Dynamic Assy (Vendor Specific Yaskawa Electric (YE) Assy) - 125 (0x7D)

Output Instance	Byte	Bit 7	Bit 6	Bit 5	Bit 4	Bit 3	Bit 2	Bit 1	Bit 0
125	0	Multi-Function Input 8	Multi-Function Input 7	Multi-Function Input 6	Multi-Function Input 5	Multi-Function Input 4	Multi-Function Input 3	Run Rev	Run Fwd
	1	Function Code							
	2	Class							
	3	Attribute							
	4	Data (Low Byte)							
	5	Data (High Byte)							
	6	Torque Reference/Torque Limit (Low Byte)							
	7	Torque Reference/Torque Limit (High Byte)							

Name	Description
Run Fwd	Forward Run Command 0: Stop 1: Forward Run
Run Rev	Reverse Run Command 0: Stop 1: Reverse Run

Name	Description
Multi-Function Input 3	Terminal S3 Function Input 0: Terminal S3 Function (H1-03) OFF 1: Terminal S3 Function (H1-03) ON
Multi-Function Input 4	Terminal S4 Function Input 0: Terminal S4 Function (H1-04) OFF 1: Terminal S4 Function (H1-04) ON
Multi-Function Input 5	Terminal S5 Function Input 0: Terminal S5 Function (H1-05) OFF 1: Terminal S5 Function (H1-05) ON
Multi-Function Input 6	Terminal S6 Function Input 0: Terminal S6 Function (H1-06) OFF 1: Terminal S6 Function (H1-06) ON
Multi-Function Input 7	Terminal S7 Function Input 0: Terminal S7 Function (H1-07) OFF 1: Terminal S7 Function (H1-07) ON
Multi-Function Input 8	Terminal S8 Function Input 0: Terminal S8 Function (H1-08) OFF 1: Terminal S8 Function (H1-08) ON
Service Code	Service Code <i>Refer to Service Code Decode Table on page 50.</i>
Class	Class Valid Classes are Control Supervisor Object (41) and AC/DC Object (42). Instance will always be 1.
Attribute	Attribute
Data	Data
Torque Reference/Torque Limit	Torque Reference/Torque Limit Sets the torque reference and torque limit in units of 0.1%. Sets the torque reference when using torque control (d5-01 = 1). Sets the torque limit when using speed control (d5-01 = 0). The torque reference and torque limit are disabled when F6-06 = 0.

**Note:** This is a paired assembly (125/135).

◆ **Speed/Torque Assy (Vendor Specific Yaskawa Electric (YE) Assy) - 126 (0x7E)**

Output Instance	Byte	Bit 7	Bit 6	Bit 5	Bit 4	Bit 3	Bit 2	Bit 1	Bit 0
126	0	Multi-Function Input 8	Multi-Function Input 7	Multi-Function Input 6	Multi-Function Input 5	Multi-Function Input 4	Multi-Function Input 3	Run Rev	Run Fwd
	1	–	–	–	–	–	–	Fault Reset	External Fault
	2	Speed Reference (Low Byte)							
	3	Speed Reference (High Byte)							
	4	Torque Reference/Torque Limit (Low Byte)							
	5	Torque Reference/Torque Limit (High Byte)							
	6	Torque Compensation (Low Byte)							
	7	Torque Compensation (High Byte)							

Name	Description
Run Fwd	Forward Run Command 0: Stop 1: Forward Run
Run Rev	Reverse Run Command 0: Stop 1: Reverse Run
Multi-Function Input 3	Terminal S3 Function Input 0: Terminal S3 Function (H1-03) OFF 1: Terminal S3 Function (H1-03) ON

## 8 Output Assemblies (Drive Consumes)

Name	Description
Multi-Function Input 4	Terminal S4 Function Input 0: Terminal S4 Function (H1-04) OFF 1: Terminal S4 Function (H1-04) ON
Multi-Function Input 5	Terminal S5 Function Input 0: Terminal S5 Function (H1-05) OFF 1: Terminal S5 Function (H1-05) ON
Multi-Function Input 6	Terminal S6 Function Input 0: Terminal S6 Function (H1-06) OFF 1: Terminal S6 Function (H1-06) ON
Multi-Function Input 7	Terminal S7 Function Input 0: Terminal S7 Function (H1-07) OFF 1: Terminal S7 Function (H1-07) ON
Multi-Function Input 8	Terminal S8 Function Input 0: Terminal S8 Function (H1-08) OFF 1: Terminal S8 Function (H1-08) ON
External Fault	External Fault EF0 0: No External Fault (EF0) 1: External Fault (EF0)
Fault Reset	Fault Reset 0: No Fault Reset 1: Fault Reset
Speed Reference	Speed Command Sets drive speed reference Unit depends on o1-03. Unit is not affected by Speed Scale SS.
Torque Reference/Torque Limit	Torque Reference/Torque Limit Sets the torque reference and torque limit in units of 0.1%. Sets the torque reference when using torque control (d5-01 = 1). Sets the torque limit when using speed control (d5-01 = 0). The torque reference and torque limit are disabled when F6-06 = 0.
Torque Compensation	Sets the amount of torque compensation. Set in units of 0.1%.

## ◆ Terminals that Change depending on the Model of the Drive

The table below lists terminals that change depending on the model of the drive.

**Table 15 Terminals that Change depending on the Model of the Drive**

Drive Type	Name	Terminal	Drive Model
YASKAWA AC Drive 1000-Series	Multi-Function Contact Output	M1-M2	All drives
	Multi-Function Photocoupler Output 1	P1-PC	CIMR-□A□, CIMR-□T□, CIMR-□K□, CIMR-□B□ <1>, CIMR-□D□
		M3-M4	CIMR-□U□, CIMR-□C□
	Multi-Function Photocoupler Output 2	P2-PC	CIMR-□A□, CIMR-□T□, CIMR-□K□, CIMR-□B□ <2>, CIMR-□D□
M5-M6		CIMR-□U□, CIMR-□C□	
YASKAWA AC Drive GA700	Multi-Function Digital Output 1	M1-M2	All drives
	Multi-Function Digital Output 2	M3-M4	All drives
	Multi-Function Digital Output 3	P1-C1	CIPR-GA70A□, CIPR-GA70T□
		M5-M6	CIPR-GA70U□, CIPR-GA70C□, CIPR-GA70B□, CIPR-GA70K□, CIPR-GA70D□
Multi-Function Digital Output 4	P2-C2	CIPR-GA70A□, CIPR-GA70T□	
YASKAWA AC Drive GA800	Multi-Function Digital Output 1	M1-M2	All drives
	Multi-Function Digital Output 2	M3-M4	All drives
	Multi-Function Digital Output 3	M5-M6	All drives

<1> Terminals will change to M3-M4 depending on the model type of CIMR-□B□. Refer to the drive instruction manual for details.

<2> Terminals will change to M5-M6 depending on the model type of CIMR-□B□. Refer to the drive instruction manual for details.

## 9 Input Assemblies (Drive Produces)

The convention in this manual is from the PLC perspective. As such, an assembly is called an “Output Assembly” when outputted from the PLC and received by this node. An “Input Assembly” is outputted from this node and read by the PLC. This section details “Input Assemblies” that are “Produced” by this drive.

### ◆ Basic Speed Control Input - 70 (0x46)

Input Instance	Byte	Bit 7	Bit 6	Bit 5	Bit 4	Bit 3	Bit 2	Bit 1	Bit 0
70	0	–	–	–	–	–	Running 1 (FWD)	–	Fault
	1	–							
	2	Speed Actual (Low Byte)							
	3	Speed Actual (High Byte)							

Name	Description
Fault	Fault 0: No Faults Occurred 1: Fault Occurred
Running1	Forward Running 0: Stop or Reverse Running 1: Forward Running
Speed Actual	Actual Drive Speed Monitors drive output frequency Speed actual data: Output frequency × 2 <sup>SS</sup> (SS: Speed scale) Range: 0 to 0xFFFF For example, when output frequency of 4096 with a speed scale of 2 Speed actual data = 4096 × 2 <sup>2</sup> = 16384 = 0x4000 Unit depends on o1-03.

**Note:** The control mode (A1-02) determines whether the value for the speed monitor is the output frequency or the actual motor speed.

Control Mode (A1-02)		Speed Actual
0	V/f	Output Frequency
0 (H6-01 = 3)	V/f with Simple PG	Motor Speed
1	V/f with PG	Motor Speed
2	OLV	Motor Speed
3	CLV	Motor Speed
4 <1>	AOLV	Motor Speed
5	OLV for PM Motor	Output Frequency
6	Advanced OLV for PM motor	Motor Speed
7	CLV for PM Motor	Motor Speed
8 <1>	EZOLV	Motor Speed

<1> AOLV(A1-02 = 4) and EZOLV(A1-02 = 8) control modes are not available for the YASKAWA AC Drive 1000-Series.

### ◆ Extended Speed Control Input - 71 (0x47)

Input Instance	Byte	Bit 7	Bit 6	Bit 5	Bit 4	Bit 3	Bit 2	Bit 1	Bit 0
71	0	At Speed	Ref from Net	Ctrl from Net	Ready	Running 2 (REV)	Running 1 (FWD)	Warning	Fault
	1	State							
	2	Speed Actual (Low Byte)							
	3	Speed Actual (High Byte)							

Name	Description
Fault	Fault 0: No Faults Occurred 1: Fault Occurred
Warning	Warning 0: No Warning Occurred 1: Warning Occurred
Running 1 (FWD)	Forward Running 0: Stop or Reverse Running 1: Forward Running
Running 2 (REV)	Reverse Running 0: Stop or Forward Running 1: Reverse Running
Ready	Drive Ready 0: Not Ready 1: Ready
Ctrl from Net	Status of Run command from Network 0: Run command is not from network 1: Run command is from network
Ref from Net	Status of Speed reference from Network 0: Speed reference is not from network 1: Speed reference is from network
At Speed	Speed Agree 0: No Speed Agree 1: Actual speed at speed reference
State	Drive Status 2: Not ready 3: Ready (Stopped) 4: Enabled (Run command present) 5: Deceleration to stop 6: Fault stop 7: Fault
Speed Actual	Actual Drive Speed Monitors drive output frequency Speed actual data: Output frequency $\times 2^{SS}$ (SS: Speed scale) Range: 0 to 0xFFFF For example, when output frequency of 4096 with a speed scale of 2 Speed actual data = $4096 \times 2^2 = 16384 = 0x4000$ Unit depends on o1-03.

◆ Speed and Torque Control Input - 72 (0x48)

Input Instance	Byte	Bit 7	Bit 6	Bit 5	Bit 4	Bit 3	Bit 2	Bit 1	Bit 0
72	0	-	-	-	-	-	Running 1 (FWD)	-	Fault
	1	-							
	2	Speed Actual (Low Byte)							
	3	Speed Actual (High Byte)							
	4	Torque Actual (Low Byte)							
	5	Torque Actual (High Byte)							

Name	Description
Fault	Fault 0: No Faults Occurred 1: Fault Occurred
Running 1	Forward Running 0: Stop or Reverse Running 1: Forward Running

## 9 Input Assemblies (Drive Produces)

Name	Description
Speed Actual	Actual Drive Speed Monitors drive output frequency Speed actual data: Output frequency $\times 2^{SS}$ (SS: Speed scale) Range: 0 to 0xFFFF For example, when output frequency of 4096 with a speed scale of 2 Speed actual data = $4096 \times 2^2 = 16384 = 0x4000$ Unit depends on o1-03.
Torque Actual	Output Torque Shows the torque reference. Value displays in 0.1% units.

### ◆ Extended Speed and Torque Control Input - 73 (0x49)

Input Instance	Byte	Bit 7	Bit 6	Bit 5	Bit 4	Bit 3	Bit 2	Bit 1	Bit 0
73	0	At Speed	Ref from Net	Ctrl from Net	Ready	Running 2 (REV)	Running 1 (FWD)	Warning	Fault
	1	State							
	2	Speed Actual (Low Byte)							
	3	Speed Actual (High Byte)							
	4	Torque Actual (Low Byte)							
	5	Torque Actual (High Byte)							

Name	Description
Fault	Fault 0: No Faults Occurred 1: Fault Occurred
Warning	Warning 0: No Warning Occurred 1: Warning Occurred
Running 1 (FWD)	Forward Running 0: Stop or Reverse Running 1: Forward Running
Running 2 (REV)	Reverse Running 0: Stop or Forward Running 1: Reverse Running
Ready	Drive Ready 0: Not Ready 1: Ready
Ctrl from Net	Status of Run command from Network 0: Run command is not from network 1: Run command is from network
Ref from Net	Status of Speed reference from Network 0: Speed reference is not from network 1: Speed reference is from network
At Speed	Speed Agree 0: No Speed Agree 1: Actual speed at speed reference
State	2: Not Ready 3: Ready (Stopped) 4: Enabled (Running) 5: Stopping (Ramping to stop) 6: Fault Stop (Ramping to stop due to fault) 7: Faulted
Speed Actual	Actual Drive Speed Monitors drive output frequency Speed actual data: Output frequency / $2^{SS}$ (SS: Speed scale) Range: 0 to 0xFFFF For example, when output frequency of 4096 with a speed scale of 2 Speed actual data = $4096 \times 2^2 = 16384 = 0x4000$ Unit depends on o1-03.



Name	Description
Torque Actual	Output Torque Shows the torque reference. Value displays in 0.1% units.

◆ **3-Wire Control Status1 (Vendor Specific Yaskawa Electric (YE) Assy) - 104 (0x68)**

Note: Available in the option software versions PRG: 1107 and later.

Output Instance	Byte	Bit 7	Bit 6	Bit 5	Bit 4	Bit 3	Bit 2	Bit 1	Bit 0
104	0	Fault	–	–	–	Direction Actual	Direction Commanded	Running	Enable
	1	Reference Selection Status				Local Status			At Speed
	2	Actual Speed (Low Byte)							
	3	Actual Speed (High Byte)							

Name	Description
Enable	Enable Status 0: Drive not ready 1: Drive ready
Running	Running Status 0: Not running 1: Running
Direction Commanded	Commanded rotational direction 0: Reverse 1: Forward
Direction Actual	Actual rotational direction 0: Forward 1: Reverse
Fault	Fault Status 0: No Fault 1: Fault
At Speed	Drive at commanded Speed 0: Not at commanded speed 1: At commanded speed
Local Status	Reference Selection Commanded Refer to <a href="#">Table 16</a> .
Reference Selection Status	Reference Selection Status Refer to <a href="#">Table 17</a> .
Actual Speed	Actual Drive Speed Unit depends on o1-03. Unit is affected by Speed Scale SS.

**Table 16 Reference Selection Command**

Speed Reference Source	Bit 3	Bit 2	Bit 1
Analog Input A2	0	0	0
From Network (Bytes 2, 3)	0	0	1
–	0	1	0
–	0	1	1
–	1	0	0
–	1	0	1
–	1	1	0
–	1	1	1

**Table 17 Reference Selection Status**

Speed Reference Source Selection	Bit 7	Bit 6	Bit 5	Bit 4
–	0	0	0	0
–	0	0	0	1
–	0	0	1	0

## 9 Input Assemblies (Drive Produces)

Speed Reference Source Selection	Bit 7	Bit 6	Bit 5	Bit 4
Preset 3 (value in parameter d1-03)	0	0	1	1
Preset 4 (value in parameter d1-04)	0	1	0	0
Preset 5 (value in parameter d1-05)	0	1	0	1
Preset 6 (value in parameter d1-06)	0	1	1	0
Preset 7 (value in parameter d1-07)	0	1	1	1
Analog Input A2	1	0	0	0
From Network (Bytes 2, 3)	1	0	0	1
–	1	0	1	0
–	1	0	1	1
–	1	1	0	0
–	1	1	0	1
–	1	1	1	0
–	1	1	1	1

### ◆ Speed Status (Vendor Specific Yaskawa Electric (YE) Assy) - 130 (0x82)

Input Instance	Byte	Bit 7	Bit 6	Bit 5	Bit 4	Bit 3	Bit 2	Bit 1	Bit 0	
130	0	Fault	Alarm	Ready	Speed Agree	Reset	REV Running	ZSP	Running	
	1	ZSV	–	<ul style="list-style-type: none"> <li>• YASKAWA AC Drive 1000-Series Multi-Function Photocoupler 2</li> <li>• YASKAWA AC Drive GA700, GA800 Multi-Function Digital Output 3</li> </ul>	<ul style="list-style-type: none"> <li>• YASKAWA AC Drive 1000-Series Multi-Function Photocoupler 1</li> <li>• YASKAWA AC Drive GA700, GA800 Multi-Function Digital Output 2</li> </ul>	<ul style="list-style-type: none"> <li>• YASKAWA AC Drive 1000-Series Multi-Function Digital Output</li> <li>• YASKAWA AC Drive GA700, GA800 Multi-Function Digital Output 1</li> </ul>	LOCAL/REMOTE	Uv	–	
	2	Output Frequency (Low Byte)								
	3	Output Frequency (High Byte)								

Name	Description
Running	Running 0: Stop 1: Forward or Reverse Running
ZSP	Zero Speed 0: Running 1: Stop or DC Injection Braking
REV Running	Reverse Running 0: Not Reverse Running 1: Reverse Running
Reset	Reset 0: No Reset 1: Reset
Speed Agree	Speed Agree 0: No Speed Agree 1: Actual speed at speed reference
Ready	Drive Ready 0: Not Ready 1: Ready
Alarm	Drive Alarm 0: No Drive Alarm 1: Alarm
Fault	Drive Fault 0: No Drive Fault 1: Fault

Name	Description
Uv	Undervoltage 0: No Undervoltage 1: Undervoltage
LOCAL/REMOTE	Status of Run command from Network 0: Run command is not from network 1: Run command is from network
<ul style="list-style-type: none"> <li>YASKAWA AC Drive 1000-Series Multi-Function Digital Output</li> <li>YASKAWA AC Drive GA700, GA800 Multi-Function Digital Output 1</li> </ul>	Terminal M1/M2 0: M1/M2 OFF 1: M1/M2 ON
<ul style="list-style-type: none"> <li>YASKAWA AC Drive 1000-Series Multi-Function Photocoupler 1</li> <li>YASKAWA AC Drive GA700, GA800 Multi-Function Digital Output 2</li> </ul>	<ul style="list-style-type: none"> <li>YASKAWA AC Drive 1000-Series Terminal P1 &lt;/&gt; 0: P1 OFF 1: P1 ON</li> <li>YASKAWA AC Drive GA700, GA800 Terminal M3/M4 0: M3/M4 OFF 1: M3/M4 ON</li> </ul>
<ul style="list-style-type: none"> <li>YASKAWA AC Drive 1000-Series Multi-Function Photocoupler 2</li> <li>YASKAWA AC Drive GA700, GA800 Multi-Function Digital Output 3</li> </ul>	<ul style="list-style-type: none"> <li>YASKAWA AC Drive 1000-Series Terminal P2 &lt;/&gt; 0: P2 OFF 1: P2 ON</li> <li>YASKAWA AC Drive GA700, GA800 Terminal P1 &lt;/&gt; 0: P1 OFF 1: P1 ON</li> </ul>
Multi-Function Digital Output4 </>	Terminal P2 </> 0: P2 OFF 1: P2 ON
ZSV	Zero Servo Completed 0: – 1: Completed
Output Frequency	Actual Drive Speed Monitors drive output frequency Unit depends on o1-03. Unit is not affected by Speed Scale SS.

</> Terminals will differ depending on the model of the drive. Refer to *Terminals that Change depending on the Model of the Drive on page 53* for information on terminals.  
 </> Multi-function digital output 4 is not available for the YASKAWA AC Drive 1000-Series.

**◆ Current Status (Vendor Specific Yaskawa Electric (YE) Assy) - 131 (0x83)**

Input Instance	Byte	Bit 7	Bit 6	Bit 5	Bit 4	Bit 3	Bit 2	Bit 1	Bit 0	
131	0	Fault	Alarm	Ready	Speed Agree	Reset	REV Running	ZSP	Running	
	1	ZSV	–	<ul style="list-style-type: none"> <li>YASKAWA AC Drive 1000-Series Multi-Function Photocoupler 2</li> <li>YASKAWA AC Drive GA700, GA800 Multi-Function Digital Output 3</li> </ul>	<ul style="list-style-type: none"> <li>YASKAWA AC Drive 1000-Series Multi-Function Photocoupler 1</li> <li>YASKAWA AC Drive GA700, GA800 Multi-Function Digital Output 2</li> </ul>	<ul style="list-style-type: none"> <li>YASKAWA AC Drive 1000-Series Multi-Function Digital Output</li> <li>YASKAWA AC Drive GA700, GA800 Multi-Function Digital Output 1</li> </ul>	LOCAL/REMOTE	Uv	–	
	2	Actual Current (Low Byte)								
	3	Actual Current (High Byte)								

## 9 Input Assemblies (Drive Produces)

Name	Description
Running	Running 0: Stop 1: Forward or Reverse Running
ZSP	Zero Speed 0: Running 1: Stop or DC Injection Braking
REV Running	Reverse Running 0: Not Reverse Running 1: Reverse Running
Reset	Reset 0: No Reset 1: Reset
Speed Agree	Speed Agree 0: No Speed Agree 1: Actual speed at speed reference
Ready	Drive Ready 0: Not Ready 1: Ready
Alarm	Drive Alarm 0: No Drive Alarm 1: Alarm
Fault	Drive Fault 0: No Drive Fault 1: Fault
Uv	Undervoltage 0: No Undervoltage 1: Undervoltage
LOCAL/REMOTE	Status of Run command from Network 0: Run command is not from network 1: Run command is from network
<ul style="list-style-type: none"> <li>YASKAWA AC Drive 1000-Series Multi-Function Digital Output</li> <li>YASKAWA AC Drive GA700, GA800 Multi-Function Digital Output 1</li> </ul>	Terminal M1/M2 0: M1/M2 OFF 1: M1/M2 ON
<ul style="list-style-type: none"> <li>YASKAWA AC Drive 1000-Series Multi-Function Photocoupler 1</li> <li>YASKAWA AC Drive GA700, GA800 Multi-Function Digital Output 2</li> </ul>	<ul style="list-style-type: none"> <li>YASKAWA AC Drive 1000-Series Terminal P1 &lt;/&gt; 0: P1 OFF 1: P1 ON</li> <li>YASKAWA AC Drive GA700, GA800 Terminal M3/M4 0: M3/M4 OFF 1: M3/M4 ON</li> </ul>
<ul style="list-style-type: none"> <li>YASKAWA AC Drive 1000-Series Multi-Function Photocoupler 2</li> <li>YASKAWA AC Drive GA700, GA800 Multi-Function Digital Output 3</li> </ul>	<ul style="list-style-type: none"> <li>YASKAWA AC Drive 1000-Series Terminal P2 &lt;/&gt; 0: P2 OFF 1: P2 ON</li> <li>YASKAWA AC Drive GA700, GA800 Terminal P1 &lt;/&gt; 0: P1 OFF 1: P1 ON</li> </ul>
Multi-Function Digital Output4 <2>	Terminal P2 </> 0: P2 OFF 1: P2 ON
ZSV	Zero Servo Completed 0: – 1: Completed
Actual Current	Actual Output Current Monitors drive output current Unit is 0.1 A Unit is not affected by Current Scale CS.

- <1> Terminals will differ depending on the model of the drive. Refer to *Terminals that Change depending on the Model of the Drive on page 53* for information on terminals.
- <2> Multi-function digital output 4 is not available for the YASKAWA AC Drive 1000-Series.

**◆ Current & Speed Status (Vendor Specific Yaskawa Electric (YE) Assy) - 132 (0x84)**

Input Instance	Byte	Bit 7	Bit 6	Bit 5	Bit 4	Bit 3	Bit 2	Bit 1	Bit 0	
132	0	Fault	Alarm	Ready	Speed Agree	Reset	REV Running	ZSP	Running	
	1	ZSV	-	<ul style="list-style-type: none"> <li>• YASKAWA AC Drive 1000-Series Multi-Function Photocoupler 2</li> <li>• YASKAWA AC Drive GA700, GA800 Multi-Function Digital Output 3</li> </ul>	<ul style="list-style-type: none"> <li>• YASKAWA AC Drive 1000-Series Multi-Function Photocoupler 1</li> <li>• YASKAWA AC Drive GA700, GA800 Multi-Function Digital Output 2</li> </ul>	<ul style="list-style-type: none"> <li>• YASKAWA AC Drive 1000-Series Multi-Function Digital Output</li> <li>• YASKAWA AC Drive GA700, GA800 Multi-Function Digital Output 1</li> </ul>	LOCAL/REMOTE	Uv	-	
	2	Actual Current (Low Byte)								
	3	Actual Current (High Byte)								
	4	Output Frequency (Low Byte)								
	5	Output Frequency (High Byte)								

Name	Description
Running	Running 0: Stop 1: Forward or Reverse Running
ZSP	Zero Speed 0: Running 1: Stop or DC Injection Braking
REV Running	Reverse Running 0: Not Reverse Running 1: Reverse Running
Reset	Reset 0: No Reset 1: Reset
Speed Agree	Speed Agree 0: No Speed Agree 1: Actual speed at speed reference
Ready	Drive Ready 0: Not Ready 1: Ready
Alarm	Drive Alarm 0: No Drive Alarm 1: Alarm
Fault	Drive Fault 0: No Drive Fault 1: Fault
Uv	Undervoltage 0: No Undervoltage 1: Undervoltage
LOCAL/REMOTE	Status of Run command from Network 0: Run command is not from network 1: Run command is from network
<ul style="list-style-type: none"> <li>• YASKAWA AC Drive 1000-Series Multi-Function Digital Output</li> <li>• YASKAWA AC Drive GA700, GA800 Multi-Function Digital Output 1</li> </ul>	Terminal M1/M2 0: M1/M2 OFF 1: M1/M2 ON

## 9 Input Assemblies (Drive Produces)

Name	Description
<ul style="list-style-type: none"> <li>YASKAWA AC Drive 1000-Series Multi-Function Photocoupler 1</li> <li>YASKAWA AC Drive GA700, GA800 Multi-Function Digital Output 2</li> </ul>	<ul style="list-style-type: none"> <li>YASKAWA AC Drive 1000-Series Terminal P1 &lt;1&gt; 0: P1 OFF 1: P1 ON</li> <li>YASKAWA AC Drive GA700, GA800 Terminal M3/M4 0: M3/M4 OFF 1: M3/M4 ON</li> </ul>
<ul style="list-style-type: none"> <li>YASKAWA AC Drive 1000-Series Multi-Function Photocoupler 2</li> <li>YASKAWA AC Drive GA700, GA800 Multi-Function Digital Output 3</li> </ul>	<ul style="list-style-type: none"> <li>YASKAWA AC Drive 1000-Series Terminal P2 &lt;1&gt; 0: P2 OFF 1: P2 ON</li> <li>YASKAWA AC Drive GA700, GA800 Terminal P1 &lt;1&gt; 0: P1 OFF 1: P1 ON</li> </ul>
Multi-Function Digital Output4 <2>	Terminal P2 <1> 0: P2 OFF 1: P2 ON
ZSV	Zero Servo Completed 0: – 1: Completed
Actual Current	Actual Output Current Monitors drive output current Unit is 0.1 A Unit is not affected by Current Scale CS.
Output Frequency	Actual Drive Speed Monitors drive output frequency Unit depends on o1-03. Unit is not affected by Speed Scale SS.

<1> Terminals will differ depending on the model of the drive. Refer to [Terminals that Change depending on the Model of the Drive on page 53](#) for information on terminals.

<2> Multi-function digital output 4 is not available for the YASKAWA AC Drive 1000-Series.

### ◆ Speed Status Dynamic Assy (Vendor Specific Yaskawa Electric (YE) Assy) - 134 (0x86)

Input Instance	Byte	Bit 7	Bit 6	Bit 5	Bit 4	Bit 3	Bit 2	Bit 1	Bit 0
134	0	Fault	Alarm	Ready	Speed Agree	Reset	REV Running	ZSP	Running
	1	Service Code							
	2	Class							
	3	Attribute							
	4	Data (Low Byte)							
	5	Data (High Byte)							
	6	Output Frequency (Low Byte)							
	7	Output Frequency (High Byte)							

Name	Description
Running	Running 0: Stop 1: Forward or Reverse Running
ZSP	Zero Speed 0: Running 1: Stop or DC Injection Braking
REV Running	Reverse Running 0: Not Reverse Running 1: Reverse Running

Name	Description
Reset	Reset 0: No Reset 1: Reset
Speed Agree	Speed Agree 0: No Speed Agree 1: Actual speed at speed reference
Ready	Drive Ready 0: Not Ready 1: Ready
Alarm	Drive Alarm 0: No Drive Alarm 1: Alarm
Fault	Drive Fault 0: No Drive Fault 1: Fault
Service Code	Service Code <i>Refer to Service Code Decode Table on page 50.</i>
Class	Class Valid Classes are Control Supervisor Object (41) and AC/DC Object (42). Instance will always be 1.
Attribute	Attribute
Data	Data If Service Code is 0x94, Data is Error Code.
Output Frequency	Actual Drive Speed Monitors drive output frequency Unit depends on o1-03. Unit is not affected by Speed Scale SS.

Note: This is a paired assembly (124/134).

Table 18 Reply Mapping - 134

Byte	Write Success	Read Success	Write Failure	Read Failure	Busy	Illegal Function Code	Function Code Equals Zero
1	0x90	0x8E	0x94	0x94	0x8E/0x90	0x94	0
2	Class Number	Class Number	0	0	Class Number	0	0
3	Attribute Number	Attribute Number	0	0	Attribute Number	0	0
4	0	Data Low Byte	DeviceNet Error Code	DeviceNet Error Code	0	0x08	0
5	0	Data High Byte	0xFF	0xFF	0	0xFF	0

◆ Current Status Dynamic Assy (Vendor Specific Yaskawa Electric (YE) Assy) - 135 (0x87)

Input Instance	Byte	Bit 7	Bit 6	Bit 5	Bit 4	Bit 3	Bit 2	Bit 1	Bit 0
135	0	Fault	Alarm	Ready	Speed Agree	Reset	REV Running	ZSP	Running
	1	Service Code							
	2	Class							
	3	Attribute							
	4	Data (Low Byte)							
	5	Data (High Byte)							
	6	Actual Current (Low Byte)							
	7	Actual Current (High Byte)							

## 9 Input Assemblies (Drive Produces)

Name	Description
Running	Running 0: Stop 1: Forward or Reverse Running
ZSP	Zero Speed 0: Running 1: Stop or DC Injection Braking
REV Running	Reverse Running 0: Not Reverse Running 1: Reverse Running
Reset	Reset 0: No Reset 1: Reset
Speed Agree	Speed Agree 0: No Speed Agree 1: Actual speed at speed reference
Ready	Drive Ready 0: Not Ready 1: Ready
Alarm	Drive Alarm 0: No Drive Alarm 1: Alarm
Fault	Drive Fault 0: No Drive Fault 1: Fault
Service Code	Service Code <i>Refer to Service Code Decode Table on page 50.</i>
Class	Class Valid Classes are Control Supervisor Object (41) and AC/DC Object (42). Instance will always be 1.
Attribute	Attribute
Data	Data If Service Code is 0x94, Data is Error Code.
Actual Current	Actual Output Current Monitors drive output current Unit is 0.1 A Unit is not affected by Current Scale CS.

**Note:** This is a paired assembly (125/135).

**Table 19 Reply Mapping - 135**

Byte	Write Success	Read Success	Write Failure	Read Failure	Busy	Illegal Function Code	Function Code Equals Zero
1	0x90	0x8E	0x94	0x94	0x8E/0x90	0x94	0
2	Class Number	Class Number	0	0	Class Number	0	0
3	Attribute Number	Attribute Number	0	0	Attribute Number	0	0
4	0	Data Low Byte	DeviceNet Error Code	DeviceNet Error Code	0	0x08	0
5	0	Data High Byte	0xFF	0xFF	0	0xFF	0



◆ Torque and Speed Status (Vendor Specific Yaskawa Electric (YE) Assy) - 136 (0x88)

Input Instance	Byte	Bit 7	Bit 6	Bit 5	Bit 4	Bit 3	Bit 2	Bit 1	Bit 0	
136	0	Fault	Alarm	Ready	Speed Agree	Reset	REV Running	ZSP	Running	
	1	ZSV	-	<ul style="list-style-type: none"> <li>• YASKAWA AC Drive 1000-Series Multi-Function Photocoupler 2</li> <li>• YASKAWA AC Drive GA700, GA800 Multi-Function Digital Output 3</li> </ul>	<ul style="list-style-type: none"> <li>• YASKAWA AC Drive 1000-Series Multi-Function Photocoupler 1</li> <li>• YASKAWA AC Drive GA700, GA800 Multi-Function Digital Output 2</li> </ul>	<ul style="list-style-type: none"> <li>• YASKAWA AC Drive 1000-Series Multi-Function Digital Output</li> <li>• YASKAWA AC Drive GA700, GA800 Multi-Function Digital Output 1</li> </ul>	LOCAL/REMOTE	Uv	-	
	2	Actual Torque (Low Byte)								
	3	Actual Torque (High Byte)								
	4	Output Frequency (Low Byte)								
	5	Output Frequency (High Byte)								
	6	Speed Reference (Low Byte)								
	7	Speed Reference (High Byte)								

Name	Description
Running	Running 0: Stop 1: Forward or Reverse Running
ZSP	Zero Speed 0: Running 1: Stop or DC Injection Braking
REV Running	Reverse Running 0: Not Reverse Running 1: Reverse Running
Reset	Reset 0: No Reset 1: Reset
Speed Agree	Speed Agree 0: No Speed Agree 1: Actual speed at speed reference
Ready	Drive Ready 0: Not Ready 1: Ready
Alarm	Drive Alarm 0: No Drive Alarm 1: Alarm
Fault	Drive Fault 0: No Drive Fault 1: Fault
Uv	Undervoltage 0: No Uv Fault 1: Fault
LOCAL/REMOTE	Status of Run command from Network 0: Run command is not from network 1: Run command is from network
<ul style="list-style-type: none"> <li>• YASKAWA AC Drive 1000-Series Multi-Function Digital Output</li> <li>• YASKAWA AC Drive GA700, GA800 Multi-Function Digital Output 1</li> </ul>	Terminal M1/M2 0: M1/M2 OFF 1: M1/M2 ON

## 9 Input Assemblies (Drive Produces)

Name	Description
<ul style="list-style-type: none"> <li>YASKAWA AC Drive 1000-Series Multi-Function Photocoupler 1</li> <li>YASKAWA AC Drive GA700, GA800 Multi-Function Digital Output 2</li> </ul>	<ul style="list-style-type: none"> <li>YASKAWA AC Drive 1000-Series Terminal P1 &lt;1&gt; 0: P1 OFF 1: P1 ON</li> <li>YASKAWA AC Drive GA700, GA800 Terminal M3/M4 0: M3/M4 OFF 1: M3/M4 ON</li> </ul>
<ul style="list-style-type: none"> <li>YASKAWA AC Drive 1000-Series Multi-Function Photocoupler 2</li> <li>YASKAWA AC Drive GA700, GA800 Multi-Function Digital Output 3</li> </ul>	<ul style="list-style-type: none"> <li>YASKAWA AC Drive 1000-Series Terminal P2 &lt;1&gt; 0: P2 OFF 1: P2 ON</li> <li>YASKAWA AC Drive GA700, GA800 Terminal P1 &lt;1&gt; 0: P1 OFF 1: P1 ON</li> </ul>
Multi-Function Digital Output4 <2>	Terminal P2 <1> 0: P2 OFF 1: P2 ON
ZSV	Zero Servo Completed 0: – 1: Completed
Actual Torque	Output Torque Shows the torque reference. Value displays in 0.1% units.
Output Frequency	Actual Drive Speed Monitors drive output frequency Unit depends on o1-03. Unit is not affected by Speed Scale SS.
Speed Reference	Frequency Reference Monitors drive frequency reference Unit depends on o1-03. Unit is not affected by Speed Scale SS.

<1> Terminals will differ depending on the model of the drive. Refer to [Terminals that Change depending on the Model of the Drive on page 53](#) for information on terminals.

<2> Multi-function digital output 4 is not available for the YASKAWA AC Drive 1000-Series.

### ◆ MEMOBUS/Modbus Message Reply (Vendor Specific Yaskawa Electric (YE) Assy) - 150 (0x96)

Input Instance	Byte	Bit 7	Bit 6	Bit 5	Bit 4	Bit 3	Bit 2	Bit 1	Bit 0
150	0	Function Code							
	1	Register Number (High Byte)							
	2	Register Number (Low Byte)							
	3	Register Data (High Byte)							
	4	Register Data (Low Byte)							

**Note:** This is a paired assembly (100/150).

**Table 20 Reply Mapping - 150**

Byte	Write Success	Read Success	Write Failure	Read Failure	Illegal Function Code	Function Code Equals Zero
0	0x10	0x03	0x90	0x83	Function Code Or-ed with 0x80	0
1	Output Assembly Register Number (High Byte)	Output Assembly Register Number (High Byte)	Output Assembly Register Number (High Byte)	Output Assembly Register Number (High Byte)	Output Assembly Register Number (High Byte)	0
2	Output Assembly Register Number (Low Byte)	Output Assembly Register Number (Low Byte)	Output Assembly Register Number (Low Byte)	Output Assembly Register Number (Low Byte)	Output Assembly Register Number (Low Byte)	0

Byte	Write Success	Read Success	Write Failure	Read Failure	Illegal Function Code	Function Code Equals Zero
3	0	Read Data (High Byte)	0	0	0	0
4	0	Read Data (Low Byte)	Error Code	Error Code	1	0

**Table 21 Error Replies - 150**

Error Code	Description
0x01	Invalid Function Code
0x02	Invalid Register Number
0x21	Upper/Lower Limit Error
0x22	Option generated busy event. The MEMOBUS/Modbus requested operation is in the process loop but the drive is not done yet. Writing “Enter” when drive is running. Attempt to write data that is read only. Attempt to write a constant when drive is running. During a CPF06 event attempting to write to registers other than A1-00 to A1-05, E1-03, o2-04.
0x23	Attempting to write during a drive undervoltage (Uv) event.
0x24	Attempting to write while the drive is storing data.

**Note:** Refer to the MEMOBUS/Modbus Data Table in the drive Technical Manual for a list of monitor data using the MEMOBUS/Modbus message area.

**◆ Standard Status 1 (Vendor Specific Yaskawa Electric (YE) Assy) - 151 (0x97)**

Output Instance	Byte	Bit 7	Bit 6	Bit 5	Bit 4	Bit 3	Bit 2	Bit 1	Bit 0
151	0	Fault	Alarm	Ready	Speed Agree	Reset	REV Running	ZSP	Running
	1	–	–	• YASKAWA AC Drive 1000-Series Multi-Function Photocoupler 2 • YASKAWA AC Drive GA700, GA800 Multi-Function Digital Output 3	• YASKAWA AC Drive 1000-Series Multi-Function Photocoupler 1 • YASKAWA AC Drive GA700, GA800 Multi-Function Digital Output 2	• YASKAWA AC Drive 1000-Series Multi-Function Digital Output • YASKAWA AC Drive GA700, GA800 Multi-Function Digital Output 1	LOCAL/REMOTE	Uv	oPE
	2	Output Frequency (Low Byte)							
	3	Output Frequency (High Byte)							
	4	Actual Torque (Low Byte)							
	5	Actual Torque (High Byte)							
	6	Actual Current (Low Byte)							
	7	Actual Current (High Byte)							

Name	Description
Running	Running 0: Stop 1: Forward or Reverse Running
ZSP	Zero Speed 0: Running 1: Stop or DC Injection Braking
REV Running	Reverse Running 0: Not Reverse Running 1: Reverse Running
Reset	Reset 0: No Reset 1: Reset
Speed Agree	Speed Agree 0: No Speed Agree 1: Actual speed at speed reference

## 9 Input Assemblies (Drive Produces)

Name	Description
Ready	Drive Ready 0: Not Ready 1: Ready
Alarm	Drive Alarm 0: No Drive Alarm 1: Alarm
Fault	Drive Fault 0: No Drive Fault 1: Fault
oPE	oPE Fault 0: No oPExx Fault 1: oPExx
Uv	Undervoltage 0: No Undervoltage 1: Undervoltage
LOCAL/REMOTE	Status of Run command from Network 0: Run command is not from network 1: Run command is from network
<ul style="list-style-type: none"> <li>YASKAWA AC Drive 1000-Series Multi-Function Digital Output</li> <li>YASKAWA AC Drive GA700, GA800 Multi-Function Digital Output 1</li> </ul>	Terminal M1/M2 0: M1/M2 OFF 1: M1/M2 ON
<ul style="list-style-type: none"> <li>YASKAWA AC Drive 1000-Series Multi-Function Photocoupler 1</li> <li>YASKAWA AC Drive GA700, GA800 Multi-Function Digital Output 2</li> </ul>	<ul style="list-style-type: none"> <li>YASKAWA AC Drive 1000-Series Terminal P1 &lt;1&gt; 0: P1 OFF 1: P1 ON</li> <li>YASKAWA AC Drive GA700, GA800 Terminal M3/M4 0: M3/M4 OFF 1: M3/M4 ON</li> </ul>
<ul style="list-style-type: none"> <li>YASKAWA AC Drive 1000-Series Multi-Function Photocoupler 2</li> <li>YASKAWA AC Drive GA700, GA800 Multi-Function Digital Output 3</li> </ul>	<ul style="list-style-type: none"> <li>YASKAWA AC Drive 1000-Series Terminal P2 &lt;1&gt; 0: P2 OFF 1: P2 ON</li> <li>YASKAWA AC Drive GA700, GA800 Terminal P1 &lt;1&gt; 0: P1 OFF 1: P1 ON</li> </ul>
Multi-Function Digital Output4 <2>	Terminal P2 <1> 0: P2 OFF 1: P2 ON
Output Frequency	Actual Drive Speed Monitors drive output frequency Unit depends on o1-03. Unit is not affected by Speed Scale SS.
Actual Torque	Output Torque Shows the torque reference. Value displays in 0.1% units.
Actual Current	Actual Output Current Monitors drive output current Unit is 0.1 A Unit is not affected by Current Scale CS.

<1> Terminals will differ depending on the model of the drive. Refer to [Terminals that Change depending on the Model of the Drive on page 53](#) for information on terminals.

<2> Multi-function digital output 4 is not available for the YASKAWA AC Drive 1000-Series.

◆ Standard Status 2 (Vendor Specific Yaskawa Electric (YE) Assy) -152 (0x98)

Input Instance	Byte	Bit 7	Bit 6	Bit 5	Bit 4	Bit 3	Bit 2	Bit 1	Bit 0	
152	0	Fault	Alarm	Ready	Speed Agree	Reset	REV Running	ZSP	Running	
	1	-	-	<ul style="list-style-type: none"> <li>YASKAWA AC Drive 1000-Series Multi-Function Photocoupler 2</li> <li>YASKAWA AC Drive GA700, GA800 Multi-Function Digital Output 3</li> </ul>	<ul style="list-style-type: none"> <li>YASKAWA AC Drive 1000-Series Multi-Function Photocoupler 1</li> <li>YASKAWA AC Drive GA700, GA800 Multi-Function Digital Output 2</li> </ul>	<ul style="list-style-type: none"> <li>YASKAWA AC Drive 1000-Series Multi-Function Digital Output</li> <li>YASKAWA AC Drive GA700, GA800 Multi-Function Digital Output 1</li> </ul>	LOCAL/REMOTE	Uv	oPE	
	2	Output Frequency (Low Byte)								
	3	Output Frequency (High Byte)								
	4	Speed Reference (Low Byte)								
	5	Speed Reference (High Byte)								
	6	Actual Current (Low Byte)								
	7	Actual Current (High Byte)								

Name	Description
Running	Running 0: Stop 1: Forward or Reverse Running
ZSP	Zero Speed 0: Running 1: Stop or DC Injection Braking
REV Running	Reverse Running 0: Not Reverse Running 1: Reverse Running
Reset	Reset 0: No Reset 1: Reset
Speed Agree	Speed Agree 0: No Speed Agree 1: Actual speed at speed reference
Ready	Drive Ready 0: Not Ready 1: Ready
Alarm	Drive Alarm 0: No Drive Alarm 1: Alarm
Fault	Drive Fault 0: No Drive Fault 1: Fault
oPE	oPE Fault 0: No oPExx Fault 1: oPExx
Uv	Undervoltage 0: No Undervoltage 1: Undervoltage
LOCAL/REMOTE	Status of Run command from Network 0: Run command is not from network 1: Run command is from network
<ul style="list-style-type: none"> <li>YASKAWA AC Drive 1000-Series Multi-Function Digital Output</li> <li>YASKAWA AC Drive GA700, GA800 Multi-Function Digital Output 1</li> </ul>	Terminal M1/M2 0: M1/M2 OFF 1: M1/M2 ON

## 9 Input Assemblies (Drive Produces)

Name	Description
<ul style="list-style-type: none"> <li>YASKAWA AC Drive 1000-Series Multi-Function Photocoupler 1</li> <li>YASKAWA AC Drive GA700, GA800 Multi-Function Digital Output 2</li> </ul>	<ul style="list-style-type: none"> <li>YASKAWA AC Drive 1000-Series Terminal P1 &lt;1&gt; 0: P1 OFF 1: P1 ON</li> <li>YASKAWA AC Drive GA700, GA800 Terminal M3/M4 0: M3/M4 OFF 1: M3/M4 ON</li> </ul>
<ul style="list-style-type: none"> <li>YASKAWA AC Drive 1000-Series Multi-Function Photocoupler 2</li> <li>YASKAWA AC Drive GA700, GA800 Multi-Function Digital Output 3</li> </ul>	<ul style="list-style-type: none"> <li>YASKAWA AC Drive 1000-Series Terminal P2 &lt;1&gt; 0: P2 OFF 1: P2 ON</li> <li>YASKAWA AC Drive GA700, GA800 Terminal P1 &lt;1&gt; 0: P1 OFF 1: P1 ON</li> </ul>
Multi-Function Digital Output4 <2>	Terminal P2 <1> 0: P2 OFF 1: P2 ON
Output Frequency	Actual Drive Speed Monitors drive output frequency Unit depends on o1-03. Unit is not affected by Speed Scale SS.
Frequency Reference	Frequency Reference Monitors drive frequency reference Unit depends on o1-03. Unit is not affected by Speed Scale SS.
Actual Current	Actual Output Current Monitors drive output current Unit is 0.1 A Unit is not affected by Current Scale CS.

<1> Terminals will differ depending on the model of the drive. Refer to [Terminals that Change depending on the Model of the Drive on page 53](#) for information on terminals.

<2> Multi-function digital output 4 is not available for the YASKAWA AC Drive 1000-Series.

### ◆ Enhanced Speed Status, Dynamic (Vendor Specific Yaskawa Electric (YE) Assy) - 155 (0x9B)

Output Instance	Byte	Bit 7	Bit 6	Bit 5	Bit 4	Bit 3	Bit 2	Bit 1	Bit 0	
155	0	Fault	Alarm	Ready	Speed Agree	Reset	REV Running	ZSP	Running	
	1	<ul style="list-style-type: none"> <li>YASKAWA AC Drive 1000-Series Multi-Function Photocoupler 2</li> <li>YASKAWA AC Drive GA700, GA800 Multi-Function Digital Output 3</li> </ul>	<ul style="list-style-type: none"> <li>YASKAWA AC Drive 1000-Series Multi-Function Photocoupler 1</li> <li>YASKAWA AC Drive GA700, GA800 Multi-Function Digital Output 2</li> </ul>	<ul style="list-style-type: none"> <li>YASKAWA AC Drive 1000-Series Multi-Function Digital Output</li> <li>YASKAWA AC Drive GA700, GA800 Multi-Function Digital Output 1</li> </ul>	LOCAL / REMOTE	Function Code High Bit	Function Code Low Bit	Uv	oPE	
	2	Output Frequency (Low Byte)								
	3	Output Frequency (High Byte)								
	4	Register Number (Low Byte)								
	5	Register Number (High Byte)								
	6	Register Data (Low Byte)								
	7	Register Data (High Byte)								

Name	Description
Running	Running 0: Stop 1: Forward or Reverse Running
ZSP	Zero Speed 0: Running 1: Stop or DC Injection Braking
REV Running	Reverse Running 0: Not Reverse Running 1: Reverse Running
Reset	Reset 0: No Reset 1: Reset
Speed Agree	Speed Agree 0: No Speed Agree 1: Actual speed at speed reference
Ready	Drive Ready 0: Not Ready 1: Ready
Alarm	Drive Alarm 0: No Drive Alarm 1: Alarm
Fault	Drive Fault 0: No Drive Fault 1: Fault
oPE	oPE Fault 0: No oPExx Fault 1: oPExx
Uv	Undervoltage 0: No Undervoltage 1: Undervoltage
Function Code	MEMOBUS/Modbus Function Code <i>Refer to Function Code Decode Table on page 39.</i>
LOCAL/REMOTE	Status of Run command from Network 0: Run command is not from network 1: Run command is from network
<ul style="list-style-type: none"> <li>• YASKAWA AC Drive 1000-Series Multi-Function Digital Output</li> <li>• YASKAWA AC Drive GA700, GA800 Multi-Function Digital Output 1</li> </ul>	Terminal M1/M2 0: M1/M2 OFF 1: M1/M2 ON
<ul style="list-style-type: none"> <li>• YASKAWA AC Drive 1000-Series Multi-Function Photocoupler 1</li> <li>• YASKAWA AC Drive GA700, GA800 Multi-Function Digital Output 2</li> </ul>	<ul style="list-style-type: none"> <li>• YASKAWA AC Drive 1000-Series Terminal P1 &lt;I&gt; 0: P1 OFF 1: P1 ON</li> <li>• YASKAWA AC Drive GA700, GA800 Terminal M3/M4 0: M3/M4 OFF 1: M3/M4 ON</li> </ul>
<ul style="list-style-type: none"> <li>• YASKAWA AC Drive 1000-Series Multi-Function Photocoupler 2</li> <li>• YASKAWA AC Drive GA700, GA800 Multi-Function Digital Output 3</li> </ul>	<ul style="list-style-type: none"> <li>• YASKAWA AC Drive 1000-Series Terminal P2 &lt;I&gt; 0: P2 OFF 1: P2 ON</li> <li>• YASKAWA AC Drive GA700, GA800 Terminal P1 &lt;I&gt; 0: P1 OFF 1: P1 ON</li> </ul>
Multi-Function Digital Output4 <D>	Terminal P2 <I> 0: P2 OFF 1: P2 ON

## 9 Input Assemblies (Drive Produces)

Name	Description
Output Frequency	Actual Drive Speed Monitors drive output frequency Unit depends on o1-03. Unit is not affected by Speed Scale SS.
Register Number	MEMOBUS/Modbus Register Number
Register Data	MEMOBUS/Modbus Register Data

<1> Terminals will differ depending on the model of the drive. Refer to [Terminals that Change depending on the Model of the Drive on page 53](#) for information on terminals.

<2> Multi-function digital output 4 is not available for the YASKAWA AC Drive 1000-Series.

- Note:**
1. This is a paired assembly (105/155).
  2. Refer to the MEMOBUS/Modbus Data Table in the drive Technical Manual for a list of monitor data using the MEMOBUS/Modbus message area.

**Table 22 Reply Mapping - 155**

Function Code Bits/Byte	Write Success	Read Success	Write Failure	Read Failure	Function Code Equal to 0 0
Function Bits (High/Low)	1 1	1 1	0 1	0 1	0 0
4	Output Assembly Register Number (Low Byte)	Output Assembly Register Number (Low Byte)	Output Assembly Register Number (Low Byte)	Output Assembly Register Number (Low Byte)	0
5	Output Assembly Register Number (High Byte)	Output Assembly Register Number (High Byte)	Output Assembly Register Number (High Byte)	Output Assembly Register Number (High Byte)	0
6	0	Read Data (Low Byte)	Error Code	Error Code	0
7	0	Read Data (High Byte)	0	0	0

**Table 23 Error Replies - 155**

Error Code	Description
0x02	Invalid Register Number
0x21	Upper/Lower Limit Error
0x22	Option generated busy event. The MEMOBUS/Modbus requested operation is in the process loop but the drive is not done yet. Writing "Enter" when drive is running. Attempt to write data that is read only. Attempt to write a parameter when drive is running. During a CPF06 event attempting to write to registers other than A1-00 to A1-05, E1-03, o2-04.
0x23	Attempting to write during a drive undervoltage (Uv) event.
0x24	Attempting to write while the drive is storing data.

- Note:** Refer to the MEMOBUS/Modbus Data Table in the drive Technical Manual for a list of monitor data using the MEMOBUS/Modbus message area.



◆ Enhanced Control Status (Vendor Specific Yaskawa Electric (YE) Assy) -156 (0x9C)

Input Instance	Byte	Bit 7	Bit 6	Bit 5	Bit 4	Bit 3	Bit 2	Bit 1	Bit 0	
156	0	Fault	Alarm	Ready	Speed Agree	Reset	REV Running	ZSP	Running	
	1	<ul style="list-style-type: none"> <li>YASKAWA AC Drive 1000-Series Multi-Function Photocoupler 2</li> <li>YASKAWA AC Drive GA700, GA800 Multi-Function Digital Output 3</li> </ul>	<ul style="list-style-type: none"> <li>YASKAWA AC Drive 1000-Series Multi-Function Photocoupler 1</li> <li>YASKAWA AC Drive GA700, GA800 Multi-Function Digital Output 2</li> </ul>	<ul style="list-style-type: none"> <li>YASKAWA AC Drive 1000-Series Multi-Function Digital Output</li> <li>YASKAWA AC Drive GA700, GA800 Multi-Function Digital Output 1</li> </ul>	-	Multi-Function Input 4	Multi-Function Input 3	Multi-Function Input 2	Multi-Function Input 1	
	2	Output Frequency (Low Byte)								
	3	Output Frequency (High Byte)								
	4	-								
	5	-								
	6	Actual Current (Low Byte)								
	7	Actual Current (High Byte)								

Name	Description
Running	Running 0: Stop 1: Forward or Reverse Running
ZSP	Zero Speed 0: Running 1: Stop or DC Injection Braking
REV Running	Reverse Running 0: Not Reverse Running 1: Reverse Running
Reset	Reset 0: No Reset 1: Reset
Speed Agree	Speed Agree 0: No Speed Agree 1: Actual speed at speed reference
Ready	Drive Ready 0: Not Ready 1: Ready
Alarm	Drive Alarm 0: No Drive Alarm 1: Alarm
Fault	Drive Fault 0: No Drive Fault 1: Fault
Multi-Function Input 1	Terminal S1 0: Terminal S1 OFF 1: Terminal S1 ON
Multi-Function Input 2	Terminal S2 0: Terminal S2 OFF 1: Terminal S2 ON
Multi-Function Input 3	Terminal S3 0: Terminal S3 OFF 1: Terminal S3 ON
Multi-Function Input 4	Terminal S4 0: Terminal S4 OFF 1: Terminal S4 ON

## 9 Input Assemblies (Drive Produces)

Name	Description
<ul style="list-style-type: none"> <li>• YASKAWA AC Drive 1000-Series Multi-Function Digital Output</li> <li>• YASKAWA AC Drive GA700, GA800 Multi-Function Digital Output 1</li> </ul>	Terminal M1/M2 0: M1/M2 OFF 1: M1/M2 ON
<ul style="list-style-type: none"> <li>• YASKAWA AC Drive 1000-Series Multi-Function Photocoupler 1</li> <li>• YASKAWA AC Drive GA700, GA800 Multi-Function Digital Output 2</li> </ul>	<ul style="list-style-type: none"> <li>• YASKAWA AC Drive 1000-Series Terminal P1 &lt;1&gt; 0: P1 OFF 1: P1 ON</li> <li>• YASKAWA AC Drive GA700, GA800 Terminal M3/M4 0: M3/M4 OFF 1: M3/M4 ON</li> </ul>
<ul style="list-style-type: none"> <li>• YASKAWA AC Drive 1000-Series Multi-Function Photocoupler 2</li> <li>• YASKAWA AC Drive GA700, GA800 Multi-Function Digital Output 3</li> </ul>	<ul style="list-style-type: none"> <li>• YASKAWA AC Drive 1000-Series Terminal P2 &lt;1&gt; 0: P2 OFF 1: P2 ON</li> <li>• YASKAWA AC Drive GA700, GA800 Terminal P1 &lt;1&gt; 0: P1 OFF 1: P1 ON</li> </ul>
Multi-Function Digital Output4 <2>	Terminal P2 <1> 0: P2 OFF 1: P2 ON
Output Frequency	Actual Drive Speed Monitors drive output frequency Unit depends on o1-03. Unit is not affected by Speed Scale SS.
Actual Current	Actual Output Current Monitors drive output current Unit is 0.1 A Unit is not affected by Current Scale CS.

<1> Terminals will differ depending on the model of the drive. Refer to [Terminals that Change depending on the Model of the Drive on page 53](#) for information on terminals.

<2> Multi-function digital output 4 is not available for the YASKAWA AC Drive 1000-Series.

**Note:** Refer to the MEMOBUS/Modbus Data Table in Appendix C of the drive Technical Manual for a list of monitor data using the MEMOBUS/Modbus message area.

◆ Standard DI/DO Status (Vendor Specific Yaskawa Electric (YE) Assy) - 157 (0x9D)

Input Instance	Byte	Bit 7	Bit 6	Bit 5	Bit 4	Bit 3	Bit 2	Bit 1	Bit 0	
157	0	Fault	Alarm	Ready	Speed Agree	Reset	REV Running	ZSP	Running	
	1	-	-	-	-	-	LOCAL/REMOTE	Uv	oPE	
	2	Multi-Function Input 8	Multi-Function Input 7	Multi-Function Input 6	Multi-Function Input 5	Multi-Function Input 4	Multi-Function Input 3	Multi-Function Input 2	Multi-Function Input 1	
	3	-	-	• YASKAWA AC Drive 1000-Series Multi-Function Photocoupler 2 • YASKAWA AC Drive GA700, GA800 Multi-Function Digital Output 3	• YASKAWA AC Drive 1000-Series Multi-Function Photocoupler 1 • YASKAWA AC Drive GA700, GA800 Multi-Function Digital Output 2	• YASKAWA AC Drive 1000-Series Multi-Function Digital Output • YASKAWA AC Drive GA700, GA800 Multi-Function Digital Output 1	-	-	-	
	4	Analog Input 1 (Low Byte)								
	5	Analog Input 1 (High Byte)								
	6	Output Frequency (Low Byte)								
	7	Output Frequency (High Byte)								

Name	Description
Running	Running 0: Stop 1: Forward or Reverse Running
ZSP	Zero Speed 0: Running 1: Stop or DC Injection Braking
REV Running	Reverse Running 0: Not Reverse Running 1: Reverse Running
Reset	Reset 0: No Reset 1: Reset
Speed Agree	Speed Agree 0: No Speed Agree 1: Actual speed at speed reference
Ready	Drive Ready 0: Not Ready 1: Ready
Alarm	Drive Alarm 0: No Drive Alarm 1: Alarm
Fault	Drive Fault 0: No Drive Fault 1: Fault
oPE	oPE Fault 0: No oPExx Fault 1: oPExx
Uv	Undervoltage 0: No Undervoltage 1: Undervoltage
LOCAL/REMOTE	Status of Run command from Network 0: Run command is not from network 1: Run command is from network

## 9 Input Assemblies (Drive Produces)

Name	Description
Multi-Function Input 1	Terminal S1 0: Terminal S1 OFF 1: Terminal S1 ON
Multi-Function Input 2	Terminal S2 0: Terminal S2 OFF 1: Terminal S2 ON
Multi-Function Input 3	Terminal S3 0: Terminal S3 OFF 1: Terminal S3 ON
Multi-Function Input 4	Terminal S4 0: Terminal S4 OFF 1: Terminal S4 ON
Multi-Function Input 5	Terminal S5 0: Terminal S5 OFF 1: Terminal S5 ON
Multi-Function Input 6	Terminal S6 0: Terminal S6 OFF 1: Terminal S6 ON
Multi-Function Input 7	Terminal S7 0: Terminal S7 OFF 1: Terminal S7 ON
Multi-Function Input 8	Terminal S8 0: Terminal S8 OFF 1: Terminal S8 ON
<ul style="list-style-type: none"> <li>• YASKAWA AC Drive 1000-Series Multi-Function Digital Output</li> <li>• YASKAWA AC Drive GA700, GA800 Multi-Function Digital Output 1</li> </ul>	Terminal M1/M2 0: M1/M2 OFF 1: M1/M2 ON
<ul style="list-style-type: none"> <li>• YASKAWA AC Drive 1000-Series Multi-Function Photocoupler 1</li> <li>• YASKAWA AC Drive GA700, GA800 Multi-Function Digital Output 2</li> </ul>	<ul style="list-style-type: none"> <li>• YASKAWA AC Drive 1000-Series Terminal P1 &lt;1&gt; 0: P1 OFF 1: P1 ON</li> <li>• YASKAWA AC Drive GA700, GA800 Terminal M3/M4 0: M3/M4 OFF 1: M3/M4 ON</li> </ul>
<ul style="list-style-type: none"> <li>• YASKAWA AC Drive 1000-Series Multi-Function Photocoupler 2</li> <li>• YASKAWA AC Drive GA700, GA800 Multi-Function Digital Output 3</li> </ul>	<ul style="list-style-type: none"> <li>• YASKAWA AC Drive 1000-Series Terminal P2 &lt;1&gt; 0: P2 OFF 1: P2 ON</li> <li>• YASKAWA AC Drive GA700, GA800 Terminal P1 &lt;1&gt; 0: P1 OFF 1: P1 ON</li> </ul>
Multi-Function Digital Output4 <2>	Terminal P2 <1> 0: P2 OFF 1: P2 ON
Analog Input 1	Analog Input A1
Output Frequency	Actual Drive Speed Monitors drive output frequency Unit depends on o1-03. Unit is not affected by Speed Scale SS.

<1> Terminals will differ depending on the model of the drive. Refer to [Terminals that Change depending on the Model of the Drive on page 53](#) for information on terminals.

<2> Multi-function digital output 4 is not available for the YASKAWA AC Drive 1000-Series.

### ◆ Enhanced Torque Status, Dynamic (Vendor Specific Yaskawa Electric (YE) Assy) - 158 (0x9E)

Input Instance	Byte	Bit 7	Bit 6	Bit 5	Bit 4	Bit 3	Bit 2	Bit 1	Bit 0	
158	0	Fault	Alarm	Ready	Speed Agree	Reset	REV Running	ZSP	Running	
	1	<ul style="list-style-type: none"> <li>• YASKAWA AC Drive 1000-Series Multi-Function Photocoupler 2</li> <li>• YASKAWA AC Drive GA700, GA800 Multi-Function Digital Output 3</li> </ul>	<ul style="list-style-type: none"> <li>• YASKAWA AC Drive 1000-Series Multi-Function Photocoupler 1</li> <li>• YASKAWA AC Drive GA700, GA800 Multi-Function Digital Output 2</li> </ul>	<ul style="list-style-type: none"> <li>• YASKAWA AC Drive 1000-Series Multi-Function Digital Output</li> <li>• YASKAWA AC Drive GA700, GA800 Multi-Function Digital Output 1</li> </ul>	LOCAL/REMOTE	Function Code High Bit	Function Code Low Bit	Uv	oPE	
	2	Actual Torque (Low Byte)								
	3	Actual Torque (High Byte)								
	4	Register Number (Low Byte)								
	5	Register Number (High Byte)								
	6	Register Data (Low Byte)								
	7	Register Data (High Byte)								

Name	Description
Running	Running 0: Stop 1: Forward or Reverse Running
ZSP	Zero Speed 0: Running 1: Stop or DC Injection Braking
REV Running	Reverse Running 0: Not Reverse Running 1: Reverse Running
Reset	Reset 0: No Reset 1: Reset
Speed Agree	Speed Agree 0: No Speed Agree 1: Actual speed at speed reference
Ready	Drive Ready 0: Not Ready 1: Ready
Alarm	Drive Alarm 0: No Drive Alarm 1: Alarm
Fault	Drive Fault 0: No Drive Fault 1: Fault
oPE	oPE Fault 0: No oPExx Fault 1: oPExx
Uv	Undervoltage 0: No Undervoltage 1: Undervoltage
Function Code	MEMOBUS/Modbus Function Code Refer to <a href="#">Table 22</a> .
LOCAL/REMOTE	Status of Run command from Network 0: Run command is not from network 1: Run command is from network

## 9 Input Assemblies (Drive Produces)

Name	Description
<ul style="list-style-type: none"> <li>YASKAWA AC Drive 1000-Series Multi-Function Digital Output</li> <li>YASKAWA AC Drive GA700, GA800 Multi-Function Digital Output 1</li> </ul>	Terminal M1/M2 0: M1/M2 OFF 1: M1/M2 ON
<ul style="list-style-type: none"> <li>YASKAWA AC Drive 1000-Series Multi-Function Photocoupler 1</li> <li>YASKAWA AC Drive GA700, GA800 Multi-Function Digital Output 2</li> </ul>	<ul style="list-style-type: none"> <li>YASKAWA AC Drive 1000-Series Terminal P1 &lt;1&gt; 0: P1 OFF 1: P1 ON</li> <li>YASKAWA AC Drive GA700, GA800 Terminal M3/M4 0: M3/M4 OFF 1: M3/M4 ON</li> </ul>
<ul style="list-style-type: none"> <li>YASKAWA AC Drive 1000-Series Multi-Function Photocoupler 2</li> <li>YASKAWA AC Drive GA700, GA800 Multi-Function Digital Output 3</li> </ul>	<ul style="list-style-type: none"> <li>YASKAWA AC Drive 1000-Series Terminal P2 &lt;1&gt; 0: P2 OFF 1: P2 ON</li> <li>YASKAWA AC Drive GA700, GA800 Terminal P1 &lt;1&gt; 0: P1 OFF 1: P1 ON</li> </ul>
Multi-Function Digital Output4 <2>	Terminal P2 <1> 0: P2 OFF 1: P2 ON
Actual Torque	Output Torque Shows the torque reference. Value displays in 0.1% units.
Register Number	MEMOBUS/Modbus Register Number
Register Data	MEMOBUS/Modbus Register Data

<1> Terminals will differ depending on the model of the drive. Refer to [Terminals that Change depending on the Model of the Drive on page 53](#) for information on terminals.

<2> Multi-function digital output 4 is not available for the YASKAWA AC Drive 1000-Series.

- Note:**
- This is a paired assembly (108/158).
  - Refer to the MEMOBUS/Modbus Data Table in the drive Technical Manual for a list of monitor data using the MEMOBUS/Modbus message area.

**Table 24 Reply Mapping - 158**

Function Code Bits/Byte	Write Success	Read Success	Write Failure	Read Failure	Function Code Equal to 0 0
Function Bits (High/Low)	1 1	1 1	0 1	0 1	0 0
4	Output Assembly Register Number (Low Byte)	Output Assembly Register Number (Low Byte)	Output Assembly Register Number (Low Byte)	Output Assembly Register Number (Low Byte)	0
5	Output Assembly Register Number (High Byte)	Output Assembly Register Number (High Byte)	Output Assembly Register Number (High Byte)	Output Assembly Register Number (High Byte)	0
6	0	Read Data (Low Byte)	Error Code	Error Code	0
7	0	Read Data (High Byte)	0	0	0

**Table 25 Error Replies - 158**

Error Code	Description
0x02	Invalid Register Number
0x21	Upper/Lower Limit Error
0x22	Option generated busy event. The MEMOBUS/Modbus requested operation is in the process loop but the drive is not done yet. Writing "Enter" when drive is running. Attempt to write data that is read only. Attempt to write a constant when drive is running. During a CPF06 event attempting to write to registers other than A1-00 to A1-05, E1-03, o2-04.
0x23	Attempting to write during a drive undervoltage (Uv) event.
0x24	Attempting to write while the drive is storing data.

### ◆ Dynamic Input Assembly (Vendor Specific Yaskawa Electric (YE) Assy) - 159 (0x9F)

This assembly is dynamic and can be configured as to what parameters are used.

**Note:** Available in the option software versions PRG: 1111 and later.

Output Instance	Byte	Bit 7
159	0	Configurable Input 1 (Low Byte)
	1	Configurable Input 1 (High Byte)
	2	Configurable Input 2 (Low Byte)
	3	Configurable Input 2 (High Byte)
	4	Configurable Input 3 (Low Byte)
	5	Configurable Input 3 (High Byte)
	6	Configurable Input 4 (Low Byte)
7	Configurable Input 4 (High Byte)	

Name	Description
Configurable Input 1	Data read from the MEMOBUS/Modbus address defined in parameter F6-68. If F6-68 = 0, then MEMOBUS/Modbus address 0x004B (Drive Status) is used.
Configurable Input 2	Data read from the MEMOBUS/Modbus address defined in parameter F6-69. If F6-69 = 0, then MEMOBUS/Modbus address 0x0041 (Output Frequency) is used.
Configurable Input 3	Data read from the MEMOBUS/Modbus address defined in parameter F6-70. If F6-70 = 0, then MEMOBUS/Modbus address 0x0026 (Output Current) is used.
Configurable Input 4	Data read from the MEMOBUS/Modbus address defined in parameter F6-71. If F6-71 = 0, then MEMOBUS/Modbus address 0x0048 (Torque) is used.

### ◆ 3-Wire Control Status2 (Vendor Specific Yaskawa Electric (YE) Assy) - 160 (0xA0)

Input Instance	Byte	Definition
160	0	Status Word (Low Byte)
	1	Status Word (High Byte)
	2	Output Frequency (0.1 Hz) (Low Byte)
	3	Output Frequency (0.1 Hz) (High Byte)

Bits	Fields (# bits)	Description
0	Ready	0 = NOT READY 1 = READY
1	Active	0 = NOT RUNNING 1 = RUNNING
2	Command Direction	0 = REV 1 = FWD
3	Actual Direction	0 = REV 1 = FWD
4	Accel	0 = Not accelerating 1 = Accelerating
5	Decel	0 = Not decelerating 1 = Decelerating
6	Alarm	Alarm
7	Fault	Fault
8	At Speed	At Speed
9	Main Freq	0 = Reference source not from option card 1 = Reference source from option card
10	Operation Command	0 = Run is not controlled by option card 1 = Run is controlled by option card
11	Reserved	Reserved
12	Digital Input 1 Status	Digital Input 1 Status
13	Digital Input 2 Status	Digital Input 2 Status
14	Digital Input 3 Status	Digital Input 3 Status

## 9 Input Assemblies (Drive Produces)

Bits	Fields (# bits)	Description
15	Digital Input 4 Status	Digital Input 4 Status

### ◆ Change of State Response (Vendor Specific Yaskawa Electric (YE) Assy) - 199 (0xC7)

**Note:** Available in the option software versions PRG: 1107 and later.

Input Instance	Byte	Bit 7	Bit 6	Bit 5	Bit 4	Bit 3	Bit 2	Bit 1	Bit 0	
199	0	Multi-Function Input 4	Multi-Function Input 3	NetCtrl	NetRef	Fault Reset	External Fault	Run Rev	Run Fwd	
	1	–	–	–	–	Multi-Function Input 8	Multi-Function Input 7	Multi-Function Input 6	Multi-Function Input 5	
	2	Fault	Alarm	Ready	Speed Agree	Reset	REV Running	ZSP	Running	
	3	NetCtrl (Status)	NetRef (Status)	–	–	–	2nd Motor	Uv	oPE	
	4	Output Frequency (Low Byte)								
	5	Output Frequency (High Byte)								
	6	Actual Torque (Low Byte)								
	7	Actual Torque (High Byte)								

Name	Description
Run Fwd	Forward Run command from Network 0: Forward Run command is not from network 1: Forward Run command is from network
Run Rev	Reverse Run command from Network 0: Reverse Run command is not from network 1: Reverse Run command is from network
External Fault	External Fault command from Network 0: External Fault command is not from network 1: External Fault command is from network
Fault Reset	Fault Reset command from Network 0: Fault Reset command is not from network 1: Fault Reset command is from network
NetRef	Reference command from Network 0: Reference command is not from network 1: Reference command is from network
NetCtrl	Run command from Network 0: Run command is not from network 1: Run command is from network
Multi-Function Input 3	Terminal S3 command by Network 0: Terminal S3 command OFF 1: Terminal S3 command ON
Multi-Function Input 4	Terminal S4 command by Network 0: Terminal S4 command OFF 1: Terminal S4 command ON
Multi-Function Input 5	Terminal S5 command by Network 0: Terminal S5 command OFF 1: Terminal S5 command ON
Multi-Function Input 6	Terminal S6 command by Network 0: Terminal S6 command OFF 1: Terminal S6 command ON
Multi-Function Input 7	Terminal S7 command by Network 0: Terminal S7 command OFF 1: Terminal S7 command ON
Multi-Function Input 8	Terminal S8 command by Network 0: Terminal S8 command OFF 1: Terminal S8 command ON
Running	Running 0: Stop 1: Forward or Reverse Running



Name	Description
ZSP	Zero Speed 0: Running 1: Stop or DC Injection Braking
REV Running	Reverse Running 0: Not Reverse Running 1: Reverse Running
Reset	Reset 0: No Reset 1: Reset
Speed Agree	Speed Agree 0: No Speed Agree 1: Actual speed at speed reference
Ready	Drive Ready 0: Not Ready 1: Ready
Alarm	Drive Alarm 0: No Drive Alarm 1: Alarm
Fault	Drive Fault 0: No Drive Fault 1: Fault
oPE	oPE Fault 0: No oPExx fault 1: oPExx
Uv	Undervoltage 0: No Undervoltage 1: Undervoltage
2nd Motor	Status of Second Motor 0: First Motor Select 1: Second Motor Select
NetRef (Status)	Status of reference command from Network 0: Reference command is not from network 1: Reference command is from network
NetCtrl (Status)	Status of Run command from Network 0: Run command is not from network 1: Run command is from network
Output Frequency	Actual Drive Speed Monitors drive output frequency Unit depends on o1-03. Unit is not affected by Speed Scale SS.
Actual Torque	Output Torque Shows the torque reference. Value displays in 0.1% units.

## 10 General Class Objects

### ◆ Identity Object - 1 (Class 0x01)

#### ■ Services Supported

Service Code No. (hex)	Service Name
0E	Get Attribute Single
10	Set Attribute Single
05	Reset

#### ■ Attributes Supported

Instance ID	Attribute	Name	Description	Get	Set	Size	Range	Default
0	1	Object Software Revision	The Identity Object software revision	○	–	Word	–	1
1	1	Vendor ID	Manufacturer code. 44 (2C Hex): Yaskawa Electric	○	–	Word	–	44 (YASKAWA)
1	2	Device Type	The device profile. The profile for this product is an AC drive. 2: AC drive	○	–	Word	–	2 (AC Drives)
1	3	Product Code	Product codes determined by the manufacturer.	○	–	Word	–	</>
1	4	Revision	Software revision for the option card.	○	–	Word	–	Depends on software
1	5	Status	The comm. status for the drive.	○	–	Word	–	0
1	6	Serial Number	Option card serial number	○	–	Long	–	Each unit is unique
1	7	Product Name	Product name.	○	–	String (14 Bytes)	–	Product-dependent ex: CIMR-AA2A0004
1	8	State	The operation status of the drive. 3: Drive ready 4: Fault	○	–	Byte	–	3
1	9	Configuration Consistency Value	Shows verification data for any parameters that have been edited from their default values.	○	–	Word	–	0000
1	10	Heartbeat Interval	Heartbeat interval.	○	○	Word	0 to 10	0=disabled

</> Product code is 2 bytes. The first byte is the drive type and the second byte is the model number of the drive.

### ◆ Message Router Object - 2 (Class 0x02)

#### ■ Services Supported

Service Code No. (hex)	Service Name
0E	Get Attribute Single

#### ■ Attributes Supported

Instance ID	Attribute	Name	Description	Get	Set	Size	Default
0	1	Object Software Revision	The Message Router object software revision	○	–	Word	1

## ◆ DeviceNet Object - 3 (Class 0x03)

### ■ Services Supported

Service Code No. (hex)	Service Name
0E	Get Attribute Single
10	Set Attribute Single
05	Reset

### ■ Attributes Supported

Instance ID	Attribute	Name	Description	Get	Set	Size	Range	Default (Hex)
0	1	Object Software Revision	The DeviceNet object software revision.	○	–	Word	–	2
1	1	MAC ID	Current Value of MAC Address	○	○ <1>	Byte	0 to 63	63
1	2	Baud Rate	Current Value of Baud Rate	○	○ <2>	Byte	0 to 3	00
1	3	Bus Off Interruption (BOI)	Operation at a Bus off Detection is shown.	○	–	Byte	00, 01	00
1	4	Bus Off Counter	The number of Bus off Detection is shown	○	–	Byte	0 to 255	00
1	5	Allocation Information	The DeviceNet communication connection information.	○	–	Byte x2	–	00, 00
1	6	MAC ID Switch Changed	Indication that MAC Address Switch Changed since last Power-up	○	–	Bool	–	0
1	7	Baud Rate Switch Changed	Indication that Baud Rate Switch Changed since last Power-up	○	–	Bool	–	0
1	8	MAC ID Switch Value	The MAC ID setting value. Setting through drive keypad, F6-50.	○	–	Byte	0 to 64	–
1	9	Baud Rate Switch Value	The Baud rate setting value. Setting through drive keypad.	○	–	Byte	0 to 4	–

<1> Set only settable when Attribute 08, F6-50 = 64

<2> Set only valid when Attribute 09, F6-51 = 3.

## ◆ Assembly Object - 4 (Class 0x04)

### ■ Services Supported

Service Code No. (hex)	Service Name
0E	Get Attribute Single
10	Set Attribute Single

### ■ Attributes Supported

Instance ID	Attribute	Name	Description	Get	Set	Size	Default
0	1	Object Software Revision	The DeviceNet Object software revision	○	–	Word	2
20	3	Data	Same function as the Basic Speed Control (Output Assembly)	○	○	Array 4 bytes	00 00 00 00
21	3	Data	Same function as the Extended Speed Control (Output Assembly)	○	○	Array 4 bytes	00 00 00 00
22	3	Data	Same function as the Speed and Torque Control (Output Assembly)	○	○	Array 6 Bytes	00 00 00 00 00 00
23	3	Data	Same function as the Extended Speed and Torque Control (Output Assembly)	○	○	Array 6 Bytes	00 00 00 00 00 00
70	3	Data	Same function as the Basic Speed Control (Input Assembly)	○	–	Array 4 bytes	00 00 00 00
71	3	Data	Same function as the Extended Speed Control (Input Assembly)	○	–	Array 4 bytes	00 00 00 00

## 10 General Class Objects

Instance ID	Attribute	Name	Description	Get	Set	Size	Default
72	3	Data	Same function as the Speed Control (Input Assembly)	○	–	Array 6 bytes	00 00 00 00 00 00
73	3	Data	Same function as the Speed and Torque Control (Input Assembly)	○	–	Array 6 bytes	00 00 00 00 00 00
100	3	Data	Same function as the MEMOBUS/Modbus Message Command (Output Assembly)	○	○	Array 5 bytes	00 00 00 00 00
101	3	Data	Same function as the Standard Control (Output Assembly)	○	○	Array 8 bytes	00 00 00 00 00 00 00 00
102	3	Data	Same function as the Accel/ Decel Time (Output Assembly)	○	○	Array 8 bytes	00 00 00 00 00 00 00 00
103 </>	3	Data	Same function as the 3-Wire Control (Output Assembly)	○	○	Array 4 bytes	00 00 00 00
104 </>	3	Data	Same function as the 3-wire control status (Input Assembly)	○	–	Array 4 bytes	00 00 00 00
105	3	Data	Same function as the Enhanced Torque Control, Dynamic (Output Assembly)	○	○	Array 8 bytes	00 00 00 00 00 00 00 00
106	3	Data	Same function as the Enhanced Control (Output Assembly)	○	○	Array 8 bytes	00 00 00 00 00 00 00 00
107	3	Data	Same function as the Standard DI/DO Control (Output Assembly)	○	○	Array 8 bytes	00 00 00 00 00 00 00 00
108	3	Data	Same function as the Enhanced Torque Control, Dynamic (Output Assembly)	○	○	Array 8 bytes	00 00 00 00 00 00 00 00
109 <2>	3	Data	Same function as the Dynamic Output Assembly (Output Assembly)	○	○	Array 8 bytes	00 00 00 00 00 00 00 00
120	3	Data	Same function as the Speed Command 1 (Output Assembly)	○	○	Array 4 bytes	00 00 00 00
121	3	Data	Same function as the Torque Command 1 (Output Assembly)	○	○	Array 4 bytes	00 00 00 00
122	3	Data	Same function as the Speed Command 2 (Output Assembly)	○	○	Array 6 bytes	00 00 00 00 00 00
123	3	Data	Same function as the Torque Command 2 (Output Assembly)	○	○	Array 6 bytes	00 00 00 00 00 00
124	3	Data	Same function as the Speed Dynamic Assy (Output Assembly)	○	○	Array 8 bytes	00 00 00 00 00 00 00 00
125	3	Data	Same function as the Torque Dynamic Assy (Output Assembly)	○	○	Array 8 bytes	00 00 00 00 00 00 00 00
126	3	Data	Same function as the Speed / Torque Assy (Output Assembly)	○	○	Array 8 bytes	00 00 00 00 00 00 00 00
130	3	Data	Same function as the Speed Status 1 (Input Assembly)	○	–	Array 4 bytes	00 00 00 00
131	3	Data	Same function as the Current Status 1 (Input Assembly)	○	–	Array 4 bytes	00 00 00 00
132	3	Data	Same function as the Current & Speed Status 1 (Input Assembly)	○	–	Array 6 bytes	00 00 00 00 00 00
134	3	Data	Same function as the Speed Status Dynamic Assy (Input Assembly)	○	–	Array 8 bytes	00 00 00 00 00 00 00 00
135	3	Data	Same function as the Current Status Dynamic Assy (Input Assembly)	○	–	Array 8 bytes	00 00 00 00 00 00 00 00
136	3	Data	Same function as the Torque and Speed Status (Input Assembly)	○	–	Array 8 bytes	00 00 00 00 00 00 00 00
150	3	Data	Same function as the MEMOBUS/Modbus Message Reply (Input Assembly)	○	–	Array 5 bytes	00 00 00 00 00
151	3	Data	Same function as the Standard Status (Input Assembly)	○	–	Array 8 bytes	00 00 00 00 00 00 00 00
152	3	Data	Same function as the Standard Status 2 (Input Assembly)	○	–	Array 8 bytes	00 00 00 00 00 00 00 00
155	3	Data	Same function as the Enhanced Speed Status (Input Assembly)	○	–	Array 8 bytes	00 00 00 00 00 00 00 00

Instance ID	Attribute	Name	Description	Get	Set	Size	Default
156	3	Data	Same function as the Enhanced Control Status (Input Assembly)	○	–	Array 8 bytes	00 00 00 00 00 00 00 00
157	3	Data	Same function as the Standard DI/DO Status (Input Assembly)	○	–	Array 8 bytes	00 00 00 00 00 00 00 00
158	3	Data	Same function as the Enhanced Torque Status, Dynamic (Input Assembly)	○	–	Array 8 bytes	00 00 00 00 00 00 00 00
159 <2>	3	Data	Same function as the Dynamic Input Assembly (Input Assembly)	○	–	Array 8 bytes	00 00 00 00 00 00 00 00
199 <1>	3	Data	Same function as the Change of State Response (Input Assembly)	○	–	Array 8 bytes	00 00 00 00 00 00 00 00

<1> Available in the option software versions PRG: 1107 and later.

<2> Available in the option software versions PRG: 1111 and later.

## ◆ DeviceNet Connection Object - 5 (Class 0x05)

### ■ Services Supported

Service Code No. (hex)	Service Name
0E	Get Attribute Single
10	Set Attribute Single

### ■ Attributes Supported

Instance ID	Attribute	Name	Description	Get	Set	Size	Range	Default
0	1	Object Software Revision	The DeviceNet Connection object software revision	○	–	Word	–	1
1 Explicit	1	State	Status of the instance. 00: Network not found or not yet connected. 01: Online, awaiting connection from the master. 02: Waiting to write the connection ID. 03: Connected successfully. 04: Timeout.	○	–	Byte	–	3
	2	Instance type	Shows the instance type. 00: Explicit message 01: I/O message	○	–	Byte	–	0
	3	Transport class trigger	Defines behavior of the connection.	○	–	Byte	–	83 H
	4	Produced connection ID	The label used in the comm. header for the drive.	○	–	Word	–	–
	5	Consumed connection ID	Set once the comm. connection is complete.	○	–	Word	–	–
	6	Initial comm characteristics	Code for the comm. type.	○	–	Byte	–	21 H
	7	Produced connection size	Maximum number of bytes that can be transmitted.	○	–	Byte	–	–
	8	Consumed connection size	Maximum number of bytes received.	○	–	Byte	–	–
	9	Expected packet rate	The time to timeout after receiving a comm. request. Rounds up to the nearest 10 ms.	○	○	Word	0 to 65535	2500
	12	Watchdog time-out action	Action taken after timeout. 00: Save value until reset or power is shut off 01: Auto delete 02: Restart while remaining connected	○	–	Byte	–	1
	13	Produced connection path length	Number of bytes for the transmission connection path.	○	–	Word	–	0
	14	Produced connection path	Specifies the application object that will produce data by this Connection Object.	○	–	Array	–	–
	15	Consumed connection path length	Number of bytes in the consumed connection path.	○	–	Word	–	0
16	Consumed connection path	Specifies the Application Object that will receive data consumed by this Connection Object.	○	–	Array	–	–	

## 10 General Class Objects

Instance ID	Attribute	Name	Description	Get	Set	Size	Range	Default
2 Polled I/O	1	State	Status of the instance. 00: Network not found or not yet connected. 01: Online, awaiting connection from the master. 02: Waiting to write the connection ID. 03: Connected successfully. 04: Timeout.	○	–	Byte	–	3
	2	Instance type	The instance type. 00: Explicit message 01: I/O message	○	–	Byte	–	1
	3	Transport class trigger	Defines behavior of the connection.	○	–	Byte	–	–
	4	Produced connection ID	The label used in the comm. header for the drive. Set once the comm. connection is complete.	○	–	Word	–	–
	5	Consumed connection ID		○	–	Word	–	–
	6	Initial comm characteristics	Code for the comm. type.	○	–	Byte	–	–
	7	Produced connection size	Maximum number of bytes that can be transmitted.	○	–	Byte	–	4
	8	Consumed connection size	Maximum number of bytes received.	○	–	Byte	–	4
	9	Expected packet rate	The time to timeout after receiving a comm. request. Rounds up to the nearest 10 ms.	○	○	Word <I>	0 to 65535	0
	12	Watchdog time-out action	Action taken after timeout. 00: Save value until reset or power is shut off 01: Auto delete 02: Restart while remaining connected	○	○	Byte	0 to 2	0
	13	Produced connection path length	Number of bytes for the transmission connection path.	○	–	Word <I>	–	6
	14	Produced connection path	Specifies the application object whose data will be produced by this Connection Object.	○	○	Array <I>	–	20 H 04 H 24 H 47 H 30 H 03 H
	15	Consumed connection path length	Number of bytes in the consumed connection path.	○	–	Word <I>	–	6
	16	Consumed connection path	Specifies the Application Object that will receive data consumed by this Connection Object.	○	○	Array <I>	–	20 H 04 H 24 H 15 H 30 H 03 H
	100	Produced connection path	Number of bytes in the consumed connection path.	○	○	Byte	–	71
101	Consumed connection path	Specifies the Application Object that will receive data consumed by this Connection Object.	○	○	Byte3	–	21	

Instance ID	Attribute	Name	Description	Get	Set	Size	Range	Default
4 COS	1	State	Status of the instance. 00: Network not found or not yet connected. 01: Online, awaiting connection from the master. 02: Waiting to write the connection ID. 03: Connected successfully. 04: Timeout.	○	–	Byte	–	1
	2	Instance type	The instance type. 00: Explicit message 01: I/O message	○	–	Byte	–	1
	3	Transport class trigger	Defines behavior of the connection.	○	–	Byte	–	0x10
	4	Produced connection ID	Shows the label used in the comm. header for the drive.	○	–	Word	–	-
	5	Consumed connection ID	Set once the comm. connection is complete.	○	–	Word	–	0xFFFF
	6	Initial comm characteristics	Code for the comm. type.	○	–	Byte	–	0x0F
	7	Produced connection size	Maximum number of bytes that can be transmitted.	○	–	Byte	–	8
	8	Consumed connection size	Maximum number of bytes received.	○	–	Byte	–	0
	9	Expected packet rate	The time to timeout after receiving a comm. request. Rounds up to the nearest 10 ms.	○	○	Word	–	0
	12	Watchdog time-out action	Action taken after timeout. 00: Save value until reset or power is shut off 01: Auto delete 02: Restart while remaining connected	○	○	Byte	–	0
	13	Produced connection path length	Number of bytes for the transmission connection path.	○	–	Word </>	–	6
	14	Produced connection path	Specifies the application object that will produce data by this Connection Object.	○	–	Array </>	–	20 H 04 H 24 H C7 H 30 H 03 H
	15	Consumed connection path length	Number of bytes in the consumed connection path.	○	–	0	–	0
	16	Consumed connection path	Specifies the Application Object that will receive data consumed by this Connection Object.	○	–	Array </>	–	0
17	Production inhibit time	–	○	○	Word	–	0	

<1> These attributes default on power-up to logical encoding. If a message is received that is in symbolic encoding, a three-byte symbolic encoded message is returned.

<2> A polled EPR time. Timing out will cause the drive to fault with a bUS fault.

## ◆ Motor Data Object - 40 (Class 0x28)

### ■ Services Supported

Service Code No. (hex)	Service Name
0E	Get Attribute Single
10	Set Attribute Single

### ■ Attributes Supported

Instance ID	Attribute	Name	Description	Get	Set	Size	Range	Default
0	1	Object Software Revision	The Motor Data Object software revision	○	–	Word	–	1

## 10 General Class Objects

Instance ID	Attribute	Name	Description	Get	Set	Size	Range	Default
1	3	Motor Type	Displays the type of motor used. 3: PM motor 7: IM motor Determined by the control mode set to A1-02. When A1-02 = 5, 6, 7, this attribute becomes 3 (PM motor). When A1-02 = 0, 1, 2, 3, this attribute becomes 7 (IM motor).	○	–	Byte	–	Depends on A1-02, Control Method Selection
1	6	Rated Current [0.1 A]	Motor rated current. Displayed in 0.1 A units. Changes according to the current scale (CS).	○	○	Byte	–	Depends on capacity
1	7	Rated Voltage [1 V]	Motor rated voltage. </> Displayed in 1 V units. Changes according to the voltage scale (VS).	○	○	Byte	–	Depends on capacity

<1> Motor rated voltage is the same as the voltage for E1-13 (Base Voltage) in the option software versions PRG: 1111 and earlier, and the voltage for E1-01 (Input AC Supply Voltage) in the option software versions PRG: 1112 and later.

### ◆ Control Supervisor Object - 41 (Class 0x29)

#### ■ Services Supported

Service Code No. (hex)	Service Name
0E	Get Attribute Single
10	Set Attribute Single
05	Reset

#### ■ Attributes Supported

Instance ID	Attribute	Name	Description	Get	Set	Size	Range	Default
0	1	Object Software Revision	Revision number of the Control Supervisor Object.	○	–	Word	–	1
1	3	Run 1 (Forward Run Command)	Forward Running 0: Stop 1: Forward Running	○	○	Byte	0, 1	0
1	4	Run 2 (Reverse Run Command)	Reverse Running 0: Stop 1: Reverse Running	○	○	Byte	0, 1	0
1	5	NetCtrl (Command)	Run command from Network 0: Depends on b1-02 1: Enables the run command from network	○	○	Byte	0, 1	0
1	6	State	Drive status. 2: Not ready 3: Ready (stopped) 4: Enabled (Run command present) 5: Deceleration to stop 6: Fault stop 7: Fault	○	–	Byte	–	3
1	7	Running 1 (FWD)	Forward Running 0: Stop 1: Forward Running	○	–	Byte	–	0
1	8	Running 1 (REV)	Reverse Running 0: Stop 1: Reverse Running	○	–	Byte	–	0
1	9	Ready	Drive Ready 0: Not ready 1: Ready	○	–	Byte	–	1



Instance ID	Attribute	Name	Description	Get	Set	Size	Range	Default
1	10	Fault	Drive Fault 0: No Drive Fault 1: Fault	○	–	Byte	–	0
1	11	Warning	Warning 0: No Warning 1: Warning	○	–	Byte	–	0
1	12	Fault Reset	Fault Reset 0: No Fault Reset 1: Fault Reset	○	○	Byte	0, 1	0
1	13	Fault Code	Current Fault Refer to <i>DeviceNet Fault Code Conversion Table on page 89</i> for details.	○	–	Word	–	0000
1	15	Control from Net (Status)	Run Command from DeviceNet 0: Enables the run command from except for DeviceNet 1: Enables the run command from DeviceNet	○	–	Byte	–	0
1	16	DeviceNet Fault Mode	Normal 2 (vendor specific)	○	–	Byte	–	2
1	17	Force Fault	External fault 0: No External Fault 1: External fault (EF0) Triggered by the rising edge of the signal	○	○	Byte	0, 1	0
1	18	Force Reset	External fault status 0: No External Fault 1: External fault Triggered by the rising edge of the signal.	○	–	Byte	–	0

### ■ DeviceNet Fault Code Conversion Table

Drive Fault Code [Dec] (MEMOBUS/Modbus #0080hex)	DeviceNet Fault Code [hex]	Description
0	0000	None
2	3220	DC Bus Undervoltage (Uv1)
3	5110	CTL PS Undervoltage (Uv2)
4	3222	MC Answerback (Uv3)
6	2120	Ground Fault (GF)
7	2300	Over Current (oC)
8	3210	DC Bus Overvoltage (ov)
9	4200	Heatsink Overtemp (oH)
10	4210	Heatsink Max Temp (oH1)
11	2220	Motor Overload (oL1)
12	2200	Inv Overload (oL2)
13	2221	Overtorque Det 1 (oL3)
14	2222	Overtorque Det 2 (oL4)
15	7110	DynBrk Transistor (rr)
16	7112	DynBrk Resistor (rH)
17	9000	External Fault 3 (EF3)
18	9000	External Fault 4 (EF4)
19	9000	External Fault 5 (EF5)
20	9000	External Fault 6 (EF6)
21	9000	External Fault 7 (EF7)
22	9000	External Fault 8 (EF8)
24	7310	Overspeed Det (oS)
25	7310	Speed Deviation (dEv)
26	7301	PG Open (PGo)
27	3130	Input Phase Loss (PF)

## 10 General Class Objects

Drive Fault Code [Dec] (MEMOBUS/Modbus #0080hex)	DeviceNet Fault Code [hex]	Description
28	3130	Output Phase Loss (LF)
29	5210	Motor Overheat 1 (PTC input) (oH3)
30	5300	Operator Disconnected (oPr)
31	6320	EEPROM R/W Error (Err)
32	3210	Motor Overheat 2(PTC input) (oH4)
33	7500	MEMOBUS/Modbus Comm Fault (CE)
34	7500	DeviceNet communication Error (bUS)
37	8321	Out of Control (CF)
38	8313	Zero-Servo Fault (SvE)
39	9000	External Fault 0 (EF0)
40	8000	PID Feedback Loss (FbL)
41	8000	Undertorque Detection 1 (UL3)
42	8000	Undertorque Detection 2 (UL4)
43	8000	High Slip Braking oL (oL7)
50	8000	Z Pulse Fall Detection (dv1)
51	8000	Z Pulse Noise Fault Detection (dv2)
52	8000	Inversion Detection(dv3)
53	8000	Inversion Prevention Detection(dv4)
54	8000	Current Imbalance (LF2)
55	8000	Pull-Out Detection (STo)
56	7000	PG Hardware Fault (PGoH)
59	1000	Too Many Speed Search Restarts (SEr)
65	8000	Excessive PID Feedback (FbH)
66	9000	External Fault (input terminal S1) (EF1)
67	9000	External Fault (input terminal S2) (EF2)
68	8000	Mechanical Weakening Detection 1 (oL5)
69	8000	Mechanical Weakening Detection 2 (UL5)
70	5000	Current Offset Fault (CoF)
73	8000	DriveWorksEZ Fault (dWFL)
77	5000	Output Voltage Detection Fault (voF)
78	7000	Braking Resistor Fault (rF)
79	7000	Braking Transistor Overload Fault (boL)
–	1000	Other faults

## ◆ AC/DC Drive Object - 42 (Class 0x2A)

### ■ Services Supported

Service Code No. (hex)	Service Name
0E	Get Attribute Single
10	Set Attribute Single

### ■ Attributes Supported

Instance ID	Attribute	Name	Description	Get	Set	Size	Range	Default
0	1	Object Software Revision	Revision number of AC/DC Drive object	○	–	Word	–	1
1	3	Speed Agree	Speed Agree 0: – 1: Speed Agree	○	–	Byte	–	0
1	4	NetRef (Command)	Status of reference command from DeviceNet 0: Reference command from DeviceNet 1: Reference command from except for DeviceNet	○	–	Byte	–	0
1	6	Drive Mode	Drive control mode. 0: OLV 0: OLV for PM motors (Read only) 0: Advanced OLV for PM motors (Read only) 1: V/f control 2: V/f control with PG 3: CLV 3: CLV for PM motors (Read only) Note: When using YASKAWA AC Drive GA700 or GA800, the following setting value "0" is added. 0: Advanced OLV (Read only) 0: EZOLV (Read only)	○	○	Byte	0 to 3	0
1	7	Speed Actual	Actual Drive Speed Unit is not affected by Speed Scale SS.	○	–	Word	–	3
1	8	Speed Reference	Frequency Reference Monitors drive frequency reference. Unit is not affected by Speed Scale SS.	○	○	Word	–	0
1	9	Current Actual	Actual Output Current Monitors drive output current Unit is 0.1 A Unit is not affected by Current Scale CS.	○	–	Word	–	0
1	11	Torque Actual	Drive Output Torque Unit is affected by Torque Scale TS	○	–	Word	–	0
1	12	Torque Reference/Torque Limit	Torque Reference/Torque Limit Sets the torque reference and torque limit. The units are determined by the torque scale. Sets the torque reference when using torque control (d5-01 = 1). Sets the torque limit when using speed control (d5-01 = 0). The torque reference and torque limit are disabled when F6-06 = 0.	○	○	Word	–	0
1	15	Power Actual [W]	Drive Output Power Unit is affected by Power Scale PS	○	–	Word	–	0
1	16	Input Voltage [V]	Drive Input Voltage Unit is affected by Voltage Scale VS	○	–	Word	–	Depends on capacity
1	17	Output Voltage [V]	Drive Output Voltage Unit is affected by Voltage Scale VS	○	–	Word	–	0
1	18	Accel Time [ms]	Acceleration Time 1 (C1-01) Units set in parameter C1-10. Unit is affected by Time scale (TS).	○	○	Word	–	2710 H
1	19	Decel Time [ms]	Deceleration Time 1 (C1-02) Units set in parameter C1-10. Unit is affected by Time scale (TS).	○	○	Word	–	2710 H

## 10 General Class Objects

Instance ID	Attribute	Name	Description	Get	Set	Size	Range	Default
1	20	Low Speed Limit Percent of Max Speed	Frequency Reference Lower Limit (d2-02)	○	○	Word	0 to 1100	0
1	21	High Speed Limit Percent of Max Speed	Frequency Reference Upper Limit (d2-01)	○	○	Word	0 to 1100	3E8 H
1	22	Speed Scale (-15 to 15)	Setting for F6-56, scale of units for speed-related data	○	○	Byte	-15 to 15	0
1	23	Current Scale (-15 to 15)	Setting for F6-57, scale of units for current-related data	○	○	Byte	-15 to 15	0
1	24	Torque Scale (-15 to 15)	Setting for F6-58, scale of units for torque-related data	○	○	Byte	-15 to 15	0
1	26	Power Scale (-15 to 15)	Setting for F6-59, scale of units for power-related data	○	○	Byte	-15 to 15	0
1	27	Voltage Scale (-15 to 15)	Setting for F6-60, scale of units for voltage-related data	○	○	Byte	-15 to 15	0
1	28	Time Scale (-15 to 15)	Setting for F6-61, scale of units for speed-related data	○	○	Byte	-15 to 15	0
1	29	Reference from Net (Status)	Status of reference command from DeviceNet 0: Reference command from DeviceNet 1: Reference command from except for DeviceNet	○	-	Byte	-	0

# 11 Vendor-Specific (Yaskawa) Class Objects

## ◆ Yaskawa Drive Parameters Object - 100 (Class 0x64)

### ■ Services Supported

Service Code No. (hex)	Service Name
0E	Get Attribute Single
10	Set Attribute Single

This is a dynamic explicit Class Object. With this Class object any drive parameter with a MEMOBUS/Modbus address greater than 0x00FF can be accessed. The mapping of Class Object instance / attribute to MEMOBUS/Modbus address is as follows.

Given a typical MEMOBUS/Modbus Address of 0xXXYY

The DeviceNet Instance value is equal to XX

The DeviceNet Attribute value is equal to YY

As an example, to access parameter b5-12 (MEMOBUS/Modbus Address = 0x01B0)

Class Object is 100 (0x64) (Always for this Class Object)

Instance = 0x01

Attribute = 0xB0

**Note:** Writing a zero to 0x0900 (Enter) stores changed parameters to the drive non-volatile memory. The maximum number of times data can be written to the EEPROM used for the drive is 100,000 times. Do not use this write command frequently. Writing a zero to 0x0910 (Accept) allows the drive to use the changed parameters. This normally is automatically sent when the parameter is changed. Read Enter Command 0x0900 or Accept Command 910 will always return a value of 0x0001.

### ■ Attributes Supported

Instance ID	Attribute	Name	Description	Get	Set	Size	Range	Default
0	1	Object Software Revision	The Yaskawa drive parameters object software revision	○	–	Word	–	1
1	00	MEMOBUS/Modbus Register 0x0100	Language selection	○	○	Word	0 to 7	1
1	01	MEMOBUS/Modbus Register 0x0101	Parameter access level	○	○	Word	0 to 2	2
1	YY	MEMOBUS/Modbus Registers 0x0100 to 0x01FF	MEMOBUS/Modbus registers 0x0100 to 0x01FF	○	○	Word	–	–
2	YY	MEMOBUS/Modbus Registers 0x0200 to 0x02FF	MEMOBUS/Modbus registers 0x0200 to 0x02FF	○	○	Word	–	–
..	..	..	..	○	○	Word	–	–
255	YY	MEMOBUS/Modbus Register 0xFF00 to 0xFFFF	MEMOBUS/Modbus registers 0xFF00 to 0xFFFF	○	○	Word	–	–

**Note:**

1. Attempting to set a read-only parameter results in a DeviceNet error code of 0x0E, Attribute Not Settable.
2. Attempting to access an invalid parameter results in a DeviceNet error code of 0x09, Invalid Attribute Value
3. Refer to the MEMOBUS/Modbus Data Table in the drive Technical Manual or a list of monitor data using the MEMOBUS/Modbus message area.

### ◆ Yaskawa Monitor/Control Object - 125 (Class 0x7D)

#### ■ Services Supported

Service Code No. (hex)	Service Name
0E	Get Attribute Single
10	Set Attribute Single

This is a dynamic explicit Class Object. Any parameter with a MEMOBUS/Modbus address lower than 0x0100 can be accessed with this class object. This class is similar to the Drive Parameters Object Class 100, except that since the most significant byte of MEMOBUS/Modbus address is always zero, the instance in this class remains at 1.

Given a typical MEMOBUS/Modbus Address of 0x00YY

The DeviceNet Instance value is equal to 0x01

The DeviceNet Attribute value is equal to YY

As an example, to access Drive Status (MEMOBUS/Modbus Address = 0x002C)

Class Object is 125 (0x7D) (Always for this Class Object)

Instance = 0x01

Attribute = 0x2C

#### ■ Attributes Supported

Instance ID	Attribute	MEMOBUS/Modbus Address	Description	Get	Set	Size
0	1	-	Object Software Revision	○	-	Word
1	1	0x0001	Drive Command Bits	○	○	Word
1	2	0x0002	Frequency Instruction	○	○	Word
..	..	..	..	○	○	Word
1	255	0x00FF	Unused	○	○	Word

- Note:**
1. Attempting to set a read-only parameter results in a DeviceNet error code of 0x0E, Attribute Not Settable.
  2. Attempting to access an invalid parameter results in a DeviceNet error code of 0x09, Invalid Attribute Value
  3. Refer to the MEMOBUS/Modbus Data Table in the drive Technical Manual or a list of monitor data using the MEMOBUS/Modbus message area.

## 12 Troubleshooting

### ◆ Drive-Side Error Codes

Drive-side error codes appear on the drive keypad. [Table 26](#) lists causes of the errors and possible corrective actions. Refer to the drive Technical Manual for additional error codes that may appear on the drive keypad.

#### ■ Faults

Both bUS (Option Communication Error) and EF0 (Option Card External Fault) can appear as either an alarm or as a fault. When a fault occurs, the keypad ALM LED remains lit. When an alarm occurs, the keypad ALM LED flashes.

Check the following items first when an error code occurs on the drive:

- Communication cable connections
- Make sure the option is properly installed to the drive
- Operation status of the controller program and controller CPU
- Did a momentary power loss interrupt communications?

**Table 26 Fault Displays, Causes, and Possible Solutions**

Keypad Display		Fault Name
bUS	bUS	Option Communication Error
		<ul style="list-style-type: none"> <li>• After establishing initial communication, the connection was lost.</li> <li>• Only detected when the run command frequency reference is assigned to the option (bl-01 = 3 or bl-02 = 3).</li> </ul>
<b>Cause</b>		<b>Possible Solution</b>
No signal was received from the PLC.		<ul style="list-style-type: none"> <li>• Check for faulty wiring.</li> <li>• Correct any wiring problems.</li> </ul>
Faulty communications wiring.		
An existing short circuit or communications disconnection.		Check disconnected cables and short circuits and repair as needed.
A data error occurred due to electric interference.		<ul style="list-style-type: none"> <li>• Counteract noise in the control circuit, main circuit, and ground wiring.</li> <li>• If a magnetic contactor is identified as a source of noise, install a surge absorber to the contactor coil.</li> <li>• Use only recommended cables or other shielded line. Ground the shield on the controller side or the drive input power side.</li> <li>• Separate all communication wiring from drive power lines. Install an EMC noise filter to the drive power supply input.</li> <li>• Counteract noise in the master controller (PLC).</li> </ul>
The option is not properly connected to the drive.		Reinstall the option.
Option is damaged		If there are no problems with the wiring and the error continues to occur, replace the option.
Network power loss		The power on the DeviceNet network cable is 0. Verify power is available between option terminals V+ (red) and V- (black).
Connection timeout		<ul style="list-style-type: none"> <li>• The option Requested Packet Interval (RPI) timer timed out</li> <li>• The option Expected Packet Rate (EPR) timer timed out.</li> <li>• Make sure that EPR time is set properly.</li> </ul>
Duplicate MAC ID		The option MAC ID and at least one other node have the same MAC ID. Verify F6-50 is set properly.
Keypad Display		Fault Name
EF0	EF0	Option Card External Fault
		The alarm function for an external device has been triggered.
<b>Cause</b>		<b>Possible Solution</b>
An external fault was received from the PLC.		<ol style="list-style-type: none"> <li>1. Remove the cause of the external fault.</li> <li>2. Reset the external fault input from the PLC.</li> </ol>
Problem with the PLC program		Check the PLC program.
Keypad Display		Fault Name
oFA00	oFA00	Option Card Connection Error (CN5-A)
		Option is not properly connected.
<b>Cause</b>		<b>Possible Solution</b>
The option card installed into port CN5-A is incompatible with the drive.		Connect the option to the correct option port. Note: PG option cards are supported by option ports CN5-B and CN5-C only.

## 12 Troubleshooting

Keypad Display		Fault Name	
oFR01	oFA01	Option Card Fault (CN5-A)	
Cause		Possible Solution	
The option connected to option port CN5-A was changed during run.		De-energize the drive and plug the option into the drive according to <a href="#">Installation Procedure on page 11</a> .	
Keypad Display		Fault Name	
oFR03, oFR04	oFA03, oFA04	Option Card Error (CN5-A)	
Cause		Possible Solutions	
A fault occurred in the option.		<ol style="list-style-type: none"> <li>1. De-energize the drive.</li> <li>2. Make sure that the option is correctly connected to the connector.</li> <li>3. If the problem continues, replace the option.</li> </ol>	
Keypad Display		Fault Name	
oFR30 to oFR43	oFA30 to oFA43	Option Card Connection Error (CN5-A)	
Cause		Possible Solution	
The option card connection to port CN5-A is faulty.		<ol style="list-style-type: none"> <li>1. Turn off the power.</li> <li>2. Check if the option is properly plugged into the option port.</li> <li>3. Replace the option if the fault continues to occur.</li> </ol>	
Keypad Display		Fault Name	
oFb00	oFb00	Option Fault (CN5-B)	
Cause		Possible Solution	
The option card installed into port CN5-A is incompatible with the drive.		Connect the option to the correct option port. Note: Use connector CN5-B when connecting DO-A3, AO-A3, or two PG options. Use connector CN5-C when connecting only one PG option.	
Keypad Display		Fault Name	
oFb02	oFb02	Option Fault (CN5-B)	
Cause		Possible Solution	
An option of the same type is already installed in option port CN5-A, CN5-B, or CN5-C.		Connect the option to the correct option port.	
Keypad Display		Fault Name	
oFC00	oFC00	Option Fault (CN5-C)	
Cause		Possible Solution	
The option card installed into port CN5-C is incompatible with the drive.		Connect the option to the correct option port. Note: AI-A3, DI-A3, and communication options are not supported by option port CN5-C.	
Keypad Display		Fault Name	
oFC02	oFC02	Option Fault	
Cause		Possible Solution	
An option of the same type is already installed in option port CN5-A, CN5-B, or CN5-C.		Connect the option to the correct option port.	

### ■ Minor Faults and Alarms

Keypad Display		Minor Fault Name	
CyPo	CyPo	Cycle Power to Active Parameters	
Cause		Possible Solution	
Although F6-15 = 1 [Comm. Option Parameters Reload = Reload Now], the drive does not update the communication option parameters.		Re-energize the drive to update the communication option parameters. Note: If the option software version is not compatible or if you install an incorrect option to the drive, it will trigger an alarm.	
		Minor Fault (H2-□□ = 10)	
		YES	



## ◆ Explicit Message Communications Errors

When there is a problem with a request message sent from the master in explicit communications, the drive will return a response message with a service code of “94” and an error code from [Table 27](#) as the data.

**Table 27 Explicit Message Error Codes, Causes, and Possible Solutions**

Error Code	Description	Cause	Possible Solution
08FF	Service not supported	The service code is incorrect.	Correct the service code.
09FF	Invalid attribute value	The attribute is incorrect.	Correct the attribute.
0CFF	Object state conflict	Attempted to change a drive constant that cannot be changed while the drive is running.	Stop the drive.
0EFF	Attribute not settable	Attempted to change a read-only attribute.	Correct the service code or attribute setting.
13FF	Not enough data	The data size is incorrect.	Correct the data size.
14FF	Attribute not supported	Attempted to execute a service that is not defined for the attribute.	Correct the service code or attribute setting.
15FF	Too much data	The data size is incorrect.	Correct the data size.
16FF	Object does not exist	An unsupported object was specified.	Correct the class or instance setting.
1FFF	Vendor specific error	Attempted to change a drive constant that cannot be changed while the drive is running. Attempted to change a drive constant to a value outside of the setting range.	Stop the drive. Specify a value that is within the setting range.
20FF	Invalid parameter	Attempted to change to a data value outside of the setting range.	Specify a data value that is within the setting range.

**Note:** Refer to the MEMOBUS/Modbus Data Table in Appendix C of the drive Technical Manual for a list of monitor data using the MEMOBUS/Modbus message area.

## ◆ DeviceNet Option Error Codes

**Table 28 DeviceNet Option Error Codes**

Drive Error Code (hex) <1>	DeviceNet Error Code (hex)	Description	Corrective Action
00	0000	None	-
01	5120	DC Bus Fuse Open (PUF)	Output Transistor Failure – Replace the drive
02	3220	DC Bus Undervolt (Uv1)	Input power fluctuation too large
03	5110	CTL PS Undervolt (Uv2)	Cycle drive power – Replace drive if fault continues
04	3222	MC Answerback (Uv3)	Cycle drive power – Replace drive if fault continues
05	2130	Short Circuit (SC)	Check drive wiring Cycle drive power – Replace drive if fault continues.
06	2120	Ground Fault (GF)	Check for motor and/or cable damage
07	2300	Over Current (oC)	Check motor, motor load and acc/dec rates
08	3210	DC Bus Overvolt (ov)	Check incoming voltage Check deceleration time
09	4200	Heatsink Overtmp (oH)	Check ambient temperature Check drive cooling fan
0A	4210	Heatsink Max Temp (oH1)	Check drive cooling fan
0B	2220	Motor Overload (oL1)	Check the load, acc/dec and cycle times Check motor rated current (E2-01)
0C	2200	Inv Overload (oL2)	Check the load, acc/dec and cycle times Check drive rating
0D	2221	Overtorque Det 1 (oL3)	Check L6-02 and L6-03 settings Check system mechanics
0E	2222	Overtorque Det 2 (oL4)	Check L6-05 and L6-06 settings Check system mechanics
0F	7110	DynBrk Transistor (tr)	Cycle drive power – Replace drive if fault continues
10	7112	DynBrk Resistor (rH)	Check load, operating speed and deceleration time

## 12 Troubleshooting

Drive Error Code (hex) <1>	DeviceNet Error Code (hex)	Description	Corrective Action
11	9000	External Fault 3 (EF3)	Multifunction digital input set to external fault Circuit at terminal is closed
12	9000	External Fault 4 (EF4)	
13	9000	External Fault 5 (EF5)	
14	9000	External Fault 6 (EF6)	
15	9000	External Fault 7 (EF7)	
16	9000	External Fault 8 (EF8)	
17	4140	Heatsink Fan (FAn)	Check drive cooling fan
18	7310	Overspeed Det (oS)	Check reference and reference gain Check F1-08 and F1-09 settings
19	7310	Speed Deviation (dEv)	Check load, acc/dec times and system mechanics Check F1-10 and F1-11 settings
1A	7301	PG Open (PGo)	Check PG card connections
1B	3130	Input Phase Loss (PF)	Excessive input voltage fluctuation
1C	3130	Output Phase Loss (LF)	Check for broken wire/loose terminals Check motor rating
1D	5210	None	-
1E	5300	Operator Disconnected (oPr)	Reconnect the keypad
1F	6320	EEPROM R/W Error (Err)	Cycle drive power – Replace drive if fault continues
20	0000	None	
21	7500	DeviceNet Comm Error (bUS)	Check DeviceNet network cable connections. Check 24VDC power supply voltage.
22			Check DeviceNet Option Card installation and connections.
23			Cycle drive power – Replace DeviceNet Option or drive if fault continues.
24			
25	8321	Out of Control (CF)	Check motor parameters Auto-tune
27	9000	External Fault 0 (EF0)	Check PLC program Check MI switch setting Check DeviceNet Option Card LEDs for fault indication

<1> Drive error code is stored in MEMOBUS/Modbus address 0080 hex.

## ■ DeviceNet Option Fault Monitors U6-98 and U6-99

The DeviceNet Option SI-N3 can declare the error/warning conditions via drive monitor parameters as shown in [Table 29](#).

**Table 29 DeviceNet Option Fault Monitor Descriptions**

Fault Condition	Fault Declared	Status Value (U6-99/U6-98)	Description
No Fault	n/a	0	No faults.
CPU Error	EF0	1	Option board failure.
PLC in Idle State	EF0	2	PLC is sending polled I/O with all data set to zero.
Force Fault	EF0	3	Network sent a message to force this node to the fault state.
Network Power Loss	BUS ERROR	1000	Power on DeviceNet network is off.
Connection Time-out	BUS ERROR	1001	This nodes timer (Expect Packet Rate) timed out.
Dup MAC ID	BUS ERROR	1002	This node and at least one other node have the same MAC ID. Another node sent its MAC ID to the network first.
Bus-Off	BUS ERROR	1003	CAN transceiver senses network error.

Two drive monitor parameters, U6-98 (OPTN LATCH STAT) and U6-99 (OPTN ACTIVE STAT), assist the user in network troubleshooting.

- U6-98 displays the first declared fault since the last fault reset or power cycle.
- U6-99 displays the present DeviceNet Option SI-N3 status.

These parameters are accessible from the DeviceNet network the or the drive keypad. A drive fault reset or power off clears and refreshes both U6-98 and U6-99.

**Note:** In the event of a PLC idle state, the action taken by the DeviceNet Option SI-N3 depends upon the value of parameter F6-54 (DeviceNet Idle Flt Det).

## ◆ Automatic Device Replacement (ADR)

This DeviceNet Interface is compatible with the ADR feature associated with Rockwell controllers and DeviceNet Scanners. ADR features Configuration Recovery and Auto Address Recovery.

### ■ Configuration Recovery (CR)

CR is the ability of the scanner to download previously uploaded and saved configuration data to the DeviceNet node.

When a DeviceNet node is removed and returned to the network or replaced with another device, an ADR-enabled scanner reads the Electronic Key of the device that is configured in the scanner. A typical setup of the Electronic Key is: Vendor ID, Product Code, Model Number and Product Revision. When the CR feature is enabled, the stored configuration is downloaded to the DeviceNet node.

If the scanner reads the Configuration Consistency Value (CCV), it will use this value to determine if a download will occur. If the CCV in the scanner does not equal the CCV in the DeviceNet node, the configuration information saved in the scanner will be downloaded to the DeviceNet node. In this implementation of DeviceNet, the CCV will always be 0.

### ■ Auto Address Recovery (AAR)

AAR is the ability of the scanner to change the MAC ID of a node to a predetermined MAC ID. To use this feature the DeviceNet node must have its MAC ID switch (F6-50) set to 64 and its actual MAC ID (F6-63) equal to 63.

If the recovering node is a replacement for another device, putting the new device on the network enables the AAR feature. A scanner with AAR enabled will search the network for a node with a MAC ID of 63 and then read its Electronic Key. If the Electronic Key matches the node being replaced, the scanner will change these MAC ID of the found device to the MAC ID of the device it is replacing.

After the MAC ID is changed, the device sends its duplicate MAC IDs and executes the CR feature. Example: With current Rockwell PLCs, the AAR feature can only be enabled if the CR feature is also enabled.

## 13 Trunk Line and Drop Line Length

Refer to [www.odva.org](http://www.odva.org) for more information regarding wiring DeviceNet networks.

### ◆ Trunk Line

The maximum allowable trunk line length depends on the type of cable used and the network baud rate. The total cable length includes the length of the trunk and the sum of all the drop lines.

**Table 30 Trunk Line Cable Length**

Baud Rate (kbps)	Thick Cable	Thin Cable
125	500 m (1640 ft)	100 m (328 ft)
250	250 m (787 ft)	100 m (328 ft)
500	100 m (328 ft)	100 m (328 ft)

To calculate the maximum total length for trunk lines of mixed thick and thin cables, use the following formulas:

- 125 kbps:  $L_{\text{thick}} + (5 \times L_{\text{thin}}) \leq 500 \text{ m (1640 ft)}$
- 250 kbps:  $L_{\text{thick}} + (2.5 \times L_{\text{thin}}) \leq 250 \text{ m (787 ft)}$
- 500 kbps:  $L_{\text{thick}} + L_{\text{thin}} \leq 100 \text{ m (328 ft)}$

### ◆ Drop Line

The drop line is measured from the tap on the trunk line to the transceiver of the DeviceNet node. The total cable length includes the length of the trunk and the sum of all the drop lines.

**Table 31 Drop Line Cable Length**

Baud Rate (kbps)	Maximum at Each Drop	Maximum Total
125	6 m (20 ft)	156 m (511 ft)
250		78 m (256 ft)
500		39 m (128 ft)

## 14 European Standards



Figure 25 CE Mark

The CE mark indicates compliance with European safety and environmental regulations. It is required for engaging in business and commerce in Europe.

European standards include the Machinery Directive for machine manufacturers, the Low Voltage Directive for electronics manufacturers, and the EMC guidelines for controlling noise.

This option displays the CE mark based on the EMC guidelines.

### EMC Guidelines: 2014/30/EU

Drives used in combination with this option and devices used in combination with the drive must also be CE certified and display the CE mark. When using drives displaying the CE mark in combination with other devices, it is ultimately the responsibility of the user to ensure compliance with CE standards. Verify that conditions meet European standards after setting up the device.

### ◆ EMC Guidelines Compliance

This drive is tested according to European standards EN 61800-3:2004/A1:2012 and complies with EMC guidelines. The CE marking is declared based on the harmonized standards.

### ■ EMC Guidelines Installation Conditions

Verify the following installation conditions to ensure that other devices and machinery used in combination with this option also comply with EMC guidelines:

1. Use dedicated shield cable for the option and external device (encoder, I/O device, master), or run the wiring through a metal conduit.
2. Keep wiring as short as possible and ground the largest possible surface area of the shield to the metal panel according to [Figure 27](#).

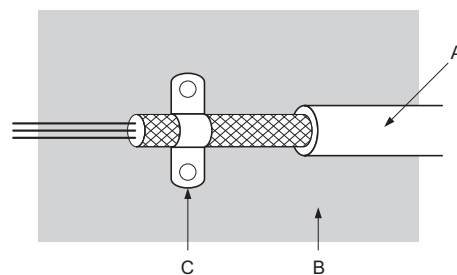

A – Braided shield cable

C – Cable clamp (conductive)

B – Metal panel

Figure 26 Ground Area

■ Option Installation for CE Compliance: Models PG-□□, DI-□□, DO-□□, AI-□□, AO-□□, SI-□□

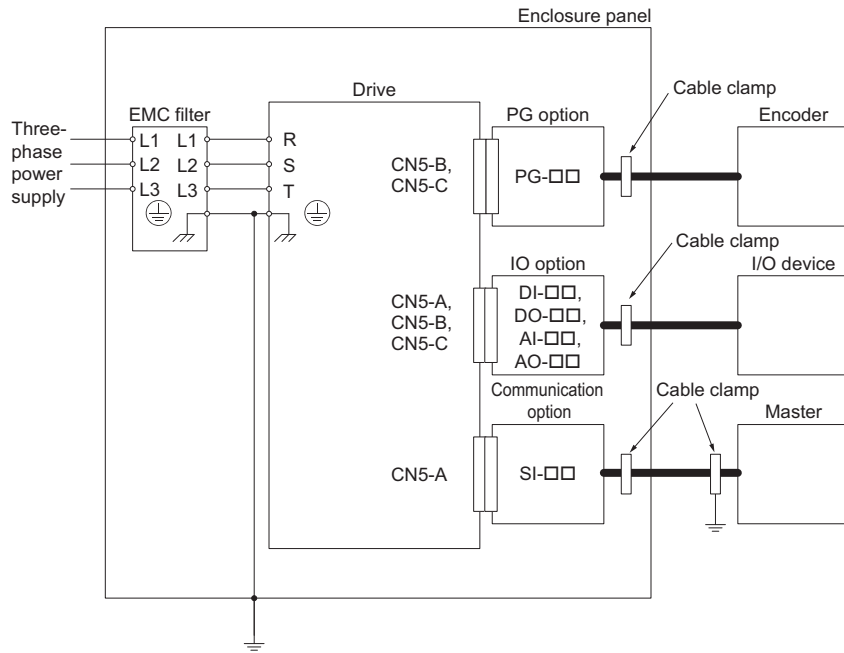

Figure 27 Option Installation for CE Compliance (PG-□□, DI-□□, DO-□□, AI-□□, AO-□□, SI-□□)

# 15 Specifications

**Table 32 Option Specifications**

Items	Specifications
<b>Model</b>	SI-N3
<b>SI-N3 Supported Messages</b>	<ul style="list-style-type: none"> <li>• Group 2 Server (UCMM capable).</li> <li>• Explicit Messages: Fragmentation is supported. Up to 32 bytes can be input and output.</li> <li>• Polled I/O Messages: Fragmentation is not supported. Up to 8 bytes can be input and output.</li> <li>• Faulted Node Recovery / Offline Connection Set Messages / Automatic Device Replacement (ADR).</li> <li>• Change of State Message (COS). COS can be used as an I/O Input Assembly.</li> </ul>
<b>I/O Assembly Instance</b>	Input: 20 types (4 to 8 bytes) Output: 20 types (4 to 8 bytes)
<b>DeviceNet Specification</b>	Conformance Level 27: Passed
<b>DeviceNet Profile</b>	AC Drive
<b>Input Power</b>	Voltage: 11 to 25 Vdc Current: 40 mA
<b>Connector Type</b>	5-pin open-style screw connector
<b>Physical Layer Type</b>	Isolated Physical Layer CAN transceiver + photocoupler
<b>MAC ID Setting</b>	Programmable from drive keypad or network: MAC ID 0 to 63
<b>Communications Speed/Baud Rate</b>	Programmable from drive keypad or network: <ul style="list-style-type: none"> <li>• 125/250/500 kbps</li> <li>• Auto Baud Rate</li> <li>• Idle Mode Detect</li> <li>• Heartbeat</li> </ul>
<b>Ambient Temperature</b>	-10°C to +50°C (14°F to 122°F)
<b>Humidity</b>	95% RH or lower with no condensation
<b>Storage Temperature</b>	-20°C to +60°C (-4°F to 140°F) allowed for short-term transport of the product
<b>Area of Use</b>	Indoors and free from: <ul style="list-style-type: none"> <li>• Oil mist, corrosive gas, flammable gas, and dust</li> <li>• Radioactive materials or flammable materials, including wood</li> <li>• Harmful gas or fluids</li> <li>• Salt</li> <li>• Direct sunlight</li> <li>• Falling foreign objects</li> </ul>
<b>Altitude</b>	1000 m (3280 ft) or lower

### ◆ Revision History

Revision dates and manual numbers appear on the bottom of the back cover.

MANUAL NO. SIEP C730600 84B <1>

Published in Japan October 2016

Revision number

Date of publication

Date of Publication	Revision Number	Section	Revised Content
January 2019	<3>	All	Addition: Applicable product series Revision: Reviewed and corrected entire documentation.
		Back cover	Revision: Address
August 2018	<2>	All	Addition: Applicable product series Revision: Reviewed and corrected entire documentation.
		Back cover	Revision: Address
October 2016	<1>	All	Revision: Applicable product series
		Back cover	Revision: Address
June 2016	-	-	First edition



# YASKAWA AC Drive Option

# DeviceNet

# Technical Manual

---

#### **DRIVE CENTER (INVERTER PLANT)**

2-13-1, Nishimiyaichi, Yukuhashi, Fukuoka, 824-8511, Japan  
Phone: +81-930-25-2548 Fax: +81-930-25-3431  
<http://www.yaskawa.co.jp>

#### **YASKAWA ELECTRIC CORPORATION**

New Pier Takeshiba South Tower, 1-16-1, Kaigan, Minatoku, Tokyo, 105-6891, Japan  
Phone: +81-3-5402-4502 Fax: +81-3-5402-4580  
<http://www.yaskawa.co.jp>

#### **YASKAWA AMERICA, INC.**

2121, Norman Drive South, Waukegan, IL 60085, U.S.A.  
Phone: +1-800-YASKAWA (927-5292) or +1-847-887-7000 Fax: +1-847-887-7310  
<http://www.yaskawa.com>

#### **YASKAWA ELÉTRICO DO BRASIL LTDA.**

777, Avenida Piraporinha, Diadema, São Paulo, 09950-000, Brasil  
Phone: +55-11-3585-1100 Fax: +55-11-3585-1187  
<http://www.yaskawa.com.br>

#### **YASKAWA EUROPE GmbH**

Hauptstraße 185, 65760 Eschborn, Germany  
Phone: +49-6196-569-300 Fax: +49-6196-569-398  
<http://www.yaskawa.eu.com> E-mail: [info@yaskawa.eu.com](mailto:info@yaskawa.eu.com)

#### **YASKAWA ELECTRIC KOREA CORPORATION**

35F, Three IFC, 10 Gukjegeumyung-ro, Yeongdeungpo-gu, Seoul, 07326, Korea  
Phone: +82-2-784-7844 Fax: +82-2-784-8495  
<http://www.yaskawa.co.kr>

#### **YASKAWA ASIA PACIFIC PTE. LTD.**

30A, Kallang Place, #06-01, 339213, Singapore  
Phone: +65-6282-3003 Fax: +65-6289-3003  
<http://www.yaskawa.com.sg>

#### **YASKAWA ELECTRIC (THAILAND) CO., LTD.**

59, 1st-5th Floor, Flourish Building, Soi Ratchadapisek 18, Ratchadapisek Road, Huaykwang, Bangkok, 10310, Thailand  
Phone: +66-2-017-0099 Fax: +66-2-017-0799  
<http://www.yaskawa.co.th>

#### **YASKAWA ELECTRIC (CHINA) CO., LTD.**

22F, Link Square 1, No.222, Hubin Road, Shanghai, 200021, China  
Phone: +86-21-5385-2200 Fax: +86-21-5385-3299  
<http://www.yaskawa.com.cn>

#### **YASKAWA ELECTRIC (CHINA) CO., LTD. BEIJING OFFICE**

Room 1011, Tower W3 Oriental Plaza, No. 1, East Chang An Ave.,  
Dong Cheng District, Beijing, 100738, China  
Phone: +86-10-8518-4086 Fax: +86-10-8518-4082

#### **YASKAWA ELECTRIC TAIWAN CORPORATION**

12F, No. 207, Sec. 3, Beishin Rd., Shindian Dist., New Taipei City 23143, Taiwan  
Phone: +886-2-8913-1333 Fax: +886-2-8913-1513 or +886-2-8913-1519  
<http://www.yaskawa.com.tw>

#### **YASKAWA INDIA PRIVATE LIMITED**

#17/A, Electronics City, Hosur Road, Bangalore, 560 100 (Karnataka), India  
Phone: +91-80-4244-1900 Fax: +91-80-4244-1901  
<http://www.yaskawaindia.in>

---

## YASKAWA

YASKAWA ELECTRIC CORPORATION

In the event that the end user of this product is to be the military and said product is to be employed in any weapons systems or the manufacture thereof, the export will fall under the relevant regulations as stipulated in the Foreign Exchange and Foreign Trade Regulations. Therefore, be sure to follow all procedures and submit all relevant documentation according to any and all rules, regulations and laws that may apply.

Specifications are subject to change without notice for ongoing product modifications and improvements.

© 2016 YASKAWA ELECTRIC CORPORATION

MANUAL NO. SIEP C730600 84D <3>-0

Published in Japan January 2019  
18-11-20