

Top View of Assembly

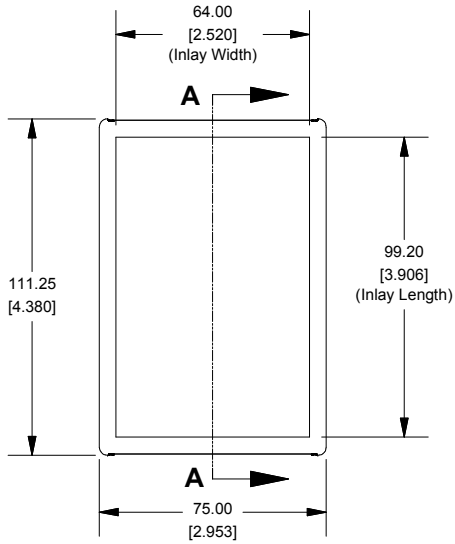

SECTION A-A (Side View Inside Assembly)

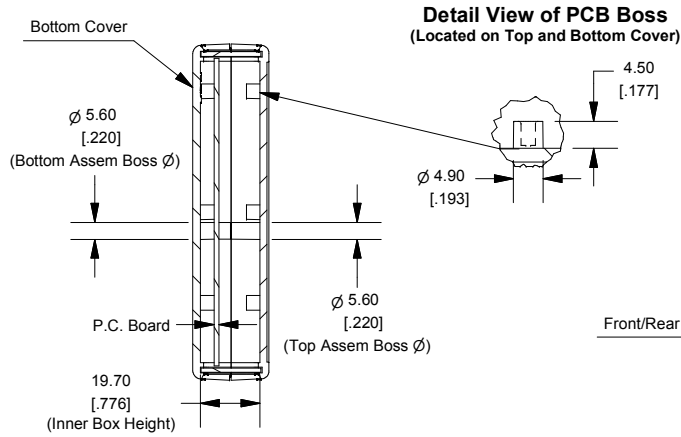

Hand Held Instrument (1593N)

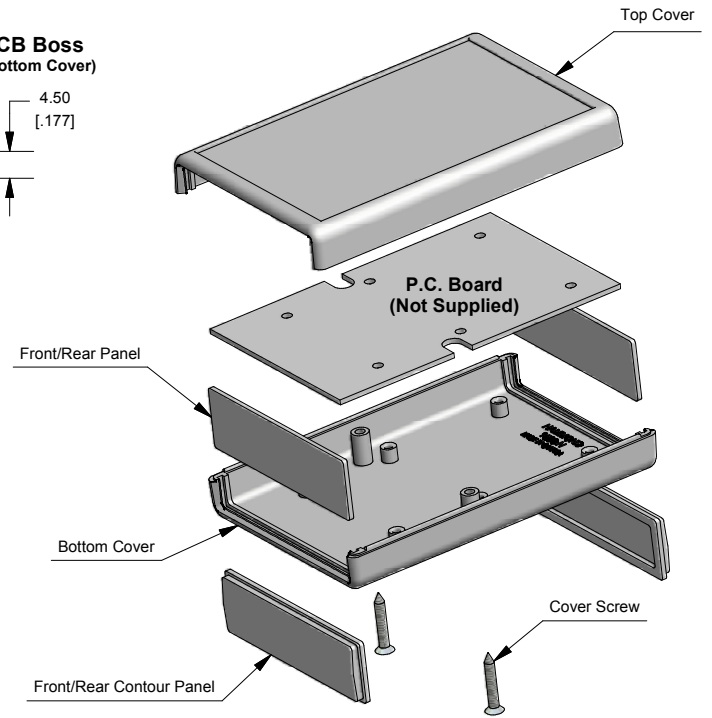

End View of Assembly

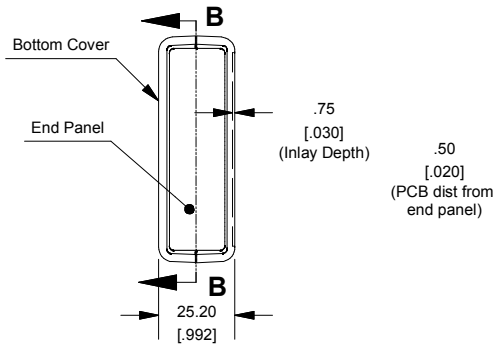

SECTION B-B (Inside of Bottom Cover)

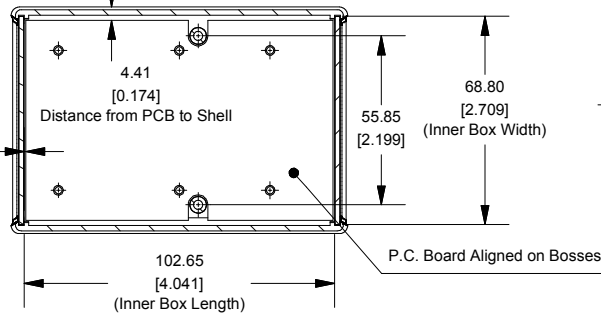

NOTE
Purchased assembly includes top and bottom cover, front and rear plastic panels (2 types - Flat and Contoured) and 2 cover screws.

Front/Rear Panel (Dashed Line Indicates Viewing Area)

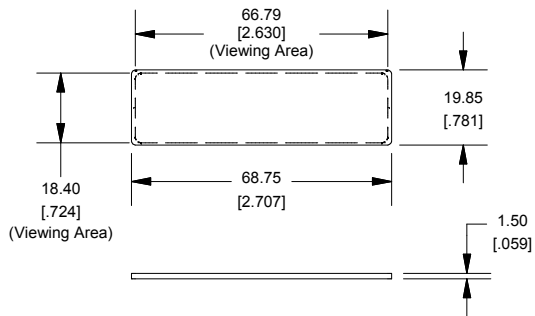

Maximum P.C. Board Size

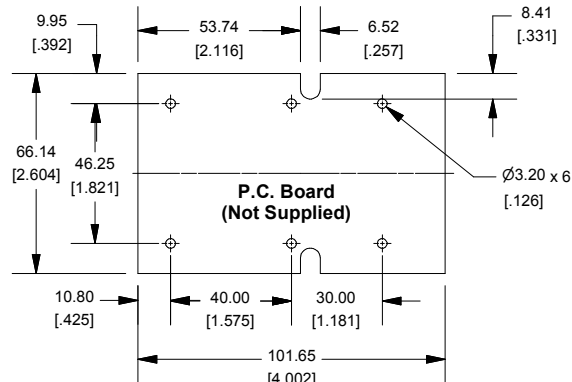

| PART NUMBERS | |
|---|--|
| 1593N Enclosure | |
| Black Enclosure | 1593NBK |
| Grey Enclosure | 1593NGY |
| ACCESSORIES | |
| Cover Screws (Pkg 100) [#4 x 3/4" self-tapping oval head (19.1mm)] | 1593QS100 |
| P.C. Board Screws [#4 x 1/4" self-tapping (6.4mm)] | 1593ATS50 (Pkg 50) 1593ATS100 (Pkg 100) |
| Belt or Pocket Clip | 1599CLIP (Black) 1599CLIPGY (Grey) |
| Infrared Panels (Pkg 10) | 1593NIR10 |

