

MAX32670 Evaluation Kit

Evaluates: MAX32670

General Description

The MAX32670 evaluation kit (EV kit) provides a platform for evaluation capabilities of the MAX32670. The MAX32670 is an ultra-low-power, cost-effective, highly reliable 32-bit microcontroller that enables designs with complex sensor processing without compromising battery life. It combines a flexible and versatile power management unit with the powerful Arm® Cortex®-M4 core with floating point unit (FPU). The MAX32670 also offers legacy designs an easy and cost optimal upgrade path from 8-bit or 16-bit microcontrollers.

EV Kit Contents

- MAX32670 EV kit containing a MAX32670
- One standard A to Micro B USB cable

Ordering Information

PART	TYPE
MAX32670EVKIT#	EV Kit

#Denotes RoHS compliance.

Features

- USB 2.0 Micro B to Serial UART Bridge
- UART0 and UART3 Interface is Selectable Through On-Board Jumpers
- On-Board MAX32625PICO-Based Debugger
- Boot Load Enable Circuitry
- SPI and I²C Signals Accessed Through 0.1in Headers
- GPIOs and Miscellaneous Signals Accessed Through 0.1in Headers
- Board Power Provided by USB Port
- On-Board SIMO Regulator and LDO for IC and Peripherals
- Individual Power Measurement on all IC Rails Through Jumpers
- Two General-Purpose LED and One General-Purpose Pushbutton Switch

PRELIMINARY

MAX32670 EV Kit Board

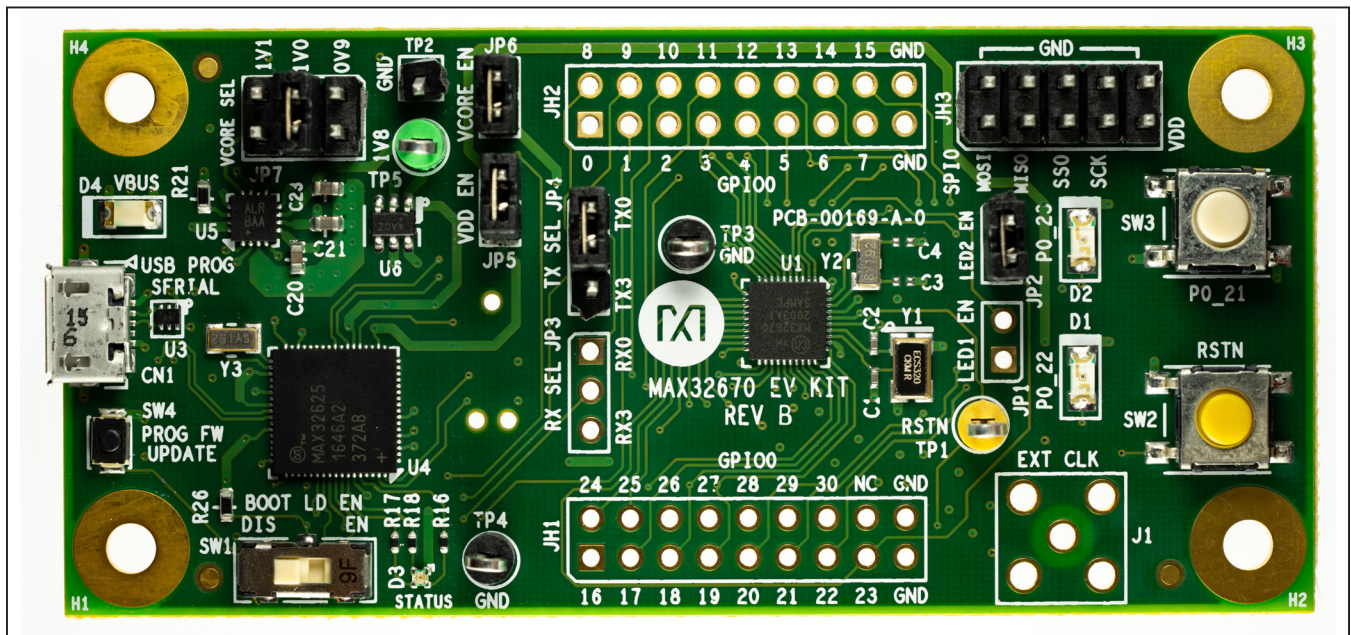

Arm and Cortex are registered trademarks of Arm Limited (or its subsidiaries) in the US and/or elsewhere.

Quick Start

Required Equipment

- MAX32670 EV kit
- One standard A to Micro B USB cable

Procedure

The EV kit is fully assembled and tested. Use the following steps to verify board operation:

- 1) While observing safe ESD practices, carefully remove the MAX32670 EV kit board out of its packaging. Inspect the board to ensure that no damage occurred during shipment. Jumpers/shunts are preinstalled prior to testing and packaging.
- 2) Power up the board by plugging in the provided USB cable to connector CN1. Verify that the blue LED (D4) illuminates and that the green LED (D2) flashes indicating successful completion of board diagnostics.

Detailed Description of Hardware (or Software)

Power Supply

The EV kit is powered by +5V that is made available through V_{BUS} on the Micro-USB type-B connector CN1.

Current Monitoring

Two pin headers provide convenient current monitoring points for V_{DD} (JP5) and V_{CORE} (JP6).

Clocking

The MAX32670 clocking is provided by an external 32MHz crystal (Y1) and an external 32.768kHz crystal (Y2) for RTC operations.

Programming and Debugging

The MAX32670 EV kit integrates a MAX32625PICO-based debugger for DAPLink functionality.

UART Interface

A USB-to-UART bridge, implemented in the MAX32625, eliminates the requirement for a physical RS-232 COM port. The bridge can be connected to UART0 or LPUART0 of the IC with jumpers JP3 (Rx) and JP4 (Tx).

Host Interface Headers

The EV kit can communicate by SPI, I²C or UART to the Host processor through 0.1in spaced headers JH2 (SPI), JH3 (I²C) and connector CN1 (UART). The interface type is set by ISEL0 jumper JP7 and ISEL1 jumper JP8.

GPIO and Alternate Function Headers

GPIO and alternate function signals from the MAX32670 can be accessed through 0.1in spaced headers JH1 and JH2.

SPI0 Header

SPI0 signals from the MAX32670 can be accessed through 0.1in spaced header JH3.

Reset Pushbutton

The IC can be reset by pushbutton SW2.

Boot Loader

Boot load is activated by boot load enable slide switch SW1.

Indicator LEDs

General-purpose indicators LED D1 (red) is connected to GPIO P0.22 and LED D2 (green) is connected to GPIO P0.23

GPIO Pushbutton Switch

General-purpose pushbutton SW3 is connected to GPIO21. If the pushbutton is pressed, the attached port pin is pulled low.

Table 1. MAX32670 EV Kit Jumper Settings

JUMPER	SIGNAL	SETTINGS	DESCRIPTION
JP1	P0_22	Open	Disconnects red LED from P0_22
		*Close	Connects red to P0_22
JP2	P0_23	Open	Disconnects green LED from P0_23
		*Close	Connects green LED to P0_23
JP3	P0_20	*2-1	Connects the USB to serial port P0_8 (UART0_RX)
	P0_26	2-3	Connects the USB to serial port P0_26 (LPUART0_RX)
JP4	P0_9	*2-1	Connects the USB to serial port P0_9 (UART0_TX)
	P0_27	2-3	Connects the USB to serial port P0_27 (LPUART0_TX)
JP5	VDD	Open	Disconnects power to VDD
		*Close	Connects power to VDD
JP6	VCORE	Open	Disconnects power to VCORE
		*Close	Connects power to VCORE
JP7	SIMO RSEL2	1-2	Sets output 2 of the SIMO regulator to 0.9V
		*3-4	Sets output 2 of the SIMO regulator to 1.0V
		5-6	Sets output 2 of the SIMO regulator to 1.1V

*Default setting.

PRELIMINARY

MAX32670 EV Kit Bill of Materials

QTY	PART REFERENCE	VALUE	BOM_DESCRIPTION	MANUFACTURER_PN	MANUFACTURER
2	C1 C2	12pF	CAP CER 12PF 50V 5% NPO 0402	CL05C120JB5NNNC	Samsung Electronics
2	C3 C4	DNI	0402		
1	C5	4.7nF	CAP CER 4700PF 50V 5% X7R 0402	GRM155R71H472JA01D	Murata Electronics
3	C6 C8 C10	100nF	CAP CER 0.1UF 16V 10% X7R 0402	GRM155R71C104KA88D	Murata Electronics
2	C7 C9	1uF	CAP CER 1UF 16V 10% X5R 0402	GRT155R61C105KE01D	Murata Electronics
1	C11	100nF	CAP CER 0.1UF 25V 10% X8R 0603	C1608X8R1E104K080AA	TDK Corporation
2	C12 C13	1uF	CAP CER 1UF 35V 10% X5R 0603	GMK107BJ105KA-T	Taiyo Yuden
6	C14 C15 C16 C17 C18 C19	1uF	CAP CER 1UF 10V 20 % X5R 0402	C0402C105M8PACTU	Kemet
3	C20 C21 C23	10uF	CAP CER 10UF 6.3V 20% X5R 0603	CL10A106MQ8NNNC	Samsung Electro
1	C22	10uF	CAP CER 10UF 25V 10% X7S 0805	GRM21BC71E106KE11L	Murata Electronics
1	C24	4.7uF	CAP CER 4.7UF 4V 20% X5R 0402	AMK105BJ475MV-F	Taiyo Yuden
1	C25	3.3nF	CAP CER 3300PF 16V 10% X7R 0402	GRM15XR71C332KA86D	Murata Electronics
1	CN1	MICRO USB B R/A	CONN RCPT 5POS MICRO USB B R/A	47346-0001	Molex
1	D1	RED	LED 660NM RED WTR CLR 1206 SMD	SML-LX1206SRC-TR	Lumex Opto
1	D2	GRN	LED 565NM WTR CLR GREEN 1206 SMD	SML-LX1206GC-TR	Lumex Opto
1	D3	SML-LX0404SIUPGUSB	LED RGB CLEAR 0404 SMD	SML-LX0404SIUPGUSB	Lumex Opto
1	D4	BLUE	LED 469NM BLUE DIFF 1206 SMD	HSMR-C150	Avago Technologies US Inc.
4	H1 H2 H3 H4	DNI	DNI MTG 125DRL 300PAD		
1	J1	SMA - DNI	CONN SMA JACK STR 50 OHM PCB	5-1814832-1	TE Connectivity
1	J2	MAXDAP	MAXDAP_POGO_PIN CBL PLUG-OF-NAI LS 10-PIN	TC2050-IDC-NL	Tag-Connect LLC
2	JH1 JH2	18P 2x9	CONN HEADER .100 DUAL STR 18POS	PEC09DAAN	Sullins
1	JH3	10P 2x5	CONN HEADER .100 DUAL STR 10POS	PEC05DAAN	Sullins
4	JP1 JP2 JP5 JP6	JUMPER	CONN HEADER .100 SINGL STR 2POS (2x1)	PEC02SAAN	Sullins
2	JP3 JP4	3P 3x1	CONN HEADER .100 SINGL STR 3POS	PEC03SAAN	Sullins
1	JP7	6P 2x3	CONN HEADER .100 DUAL STR 6POS	PEC03DAAN	Sullins
1	L1	HZ1206C202R-10	FERRITE CHIP SIGNAL 2000 OHM SMD	HZ1206C202R-10	Laird-Signal Integrity Products
1	L2	BLM21PG2215N1D	FERRITE CHIP 220 OHM 0805	BLM21PG2215N1D	Murata Electronics
1	L3	2.2uH	FIXED IND 2.2UH 1A 150 MOHM SMD 0805	MLP2012H2R2MT0S1	TDK Corporation
1	PCB1	PCB			
2	Q1 Q2	VP2110K1-G	MOSFET P-CH 100V 0.12A SOT23-3	VP2110K1-G	Microchip Technology
1	R1	0	RES SMD 0 OHM JUMPER 1/10W 0603	RC0603JR-070RL	Yageo
1	R2	0 - DNI	RES SMD 0 OHM JUMPER 1/10W 0603	RC0603JR-070RL	Yageo
7	R3 R4 R5 R6 R7 R8 R26	10K	RES 10K OHM 1/10W 1% 0603 SMD	ERJ-3EKF1002V	Panasonic
2	R9 R10	1K	RES 1K OHM 1/10W 1% 0603 SMD	ERJ-3EKF1001V	Panasonic

PRELIMINARY

MAX32670 EV Kit Bill of Materials (continued)

QTY	PART REFERENCE	VALUE	BOM_DESCRIPTION	MANUFACTURER_PN	MANUFACTURER
2	R11 R13	150K	RES 150K OHM 1/10W 1% 0603 SMD	ERJ-3EKF1503V	Panasonic
1	R12	470	RES 470 OHM 1/10W 1% 0603 SMD	ERJ-3EKF4700V	Panasonic
1	R14	332	RES 332 OHM 1/10W 1% 0603 SMD	ERJ-3EKF3320V	Panasonic
1	R15	100	RES SMD 100 OHM 1% 1/10W 0603	RC0603FR-07100RL	Yageo
1	R16	2.7K	RES SMD 2.7K OHM 1% 1/10W 0402	ERJ-2RKF2701X	Panasonic
1	R17	1.4K	RES SMD 1.4K OHM 1% 1/10W 0402	ERJ-2RKF1401X	Panasonic
1	R18	1K	RES 1K OHM 1/10W 1% 0402 SMD	ERJ-2RKF1001X	Panasonic
1	R19	1M	RES SMD 1M OHM 5% 1/8W 0805	ERJ-6GEYJ105V	Panasonic
1	R20	2.7K	RES 2.7K OHM 1/10W 1% 0603 SMD	ERJ-3EKF2701V	Panasonic
1	R21	133K	RES SMD 133K OHM 1% 1/10W 0603	ERJ-3EKF1333V	Panasonic
1	R22	324K	RES SMD 324K OHM 1% 1/10W 0603	ERJ-3EKF3243V	Panasonic
1	R23	909K	RES SMD 909K OHM 1% 1/10W 0603	ERJ-3EKF9093V	Panasonic
1	R24	768K	RES SMD 768K OHM 1% 1/10W 0603	ERJ-3EKF7683V	Panasonic
1	R25	634K	RES SMD 634K OHM 1% 1/10W 0603	ERJ-3EKF6343V	Panasonic
1	SW1	CL-SB-12A-01T	SWITCH SLIDE SPDT 200MA 12V	CL-SB-12A-01T	Nidec Copal Electronics
1	SW2	B3S-1002 BY OMZ	SWITCH TACTILE SPST-NO 0.05A 24V	B3S-1002 BY OMZ	Omron Electronics
1	SW3	B3S-1000P	SWITCH TACTILE SPST-NO 0.05A 24V	B3S-1000P	Omron Electronics
1	SW4	B3U-1000P	SWITCH TACTILE SPST-NO 0.05A 12V	B3U-1000P	Omron Electronics
1	TP1	YLW	TEST POINT PC MULTI PURPOSE YEL	5014	Keystone Electronics
1	TP2	1P	CONN HEADER .100 SINGL STR 1POS	PEC01SAAN	Sullins
2	TP3 TP4	BLK	TEST POINT PC MULTI PURPOSE BLK	5011	Keystone Electronics
1	TP5	GRN	TEST POINT PC MULTI PURPOSE GRN	5126	Keystone Electronics
1	U1	MAX32670GTL+	MAX32670GTL+ 40P TQFN	MAX32670GTL+	Maxim Integrate
1	U2	NC7WZ08K8X	IC GATE AND 2CH 2-INP US8	NC7WZ08K8X	ON Semiconductor
1	U3	MAX13202EALT+T	ESD PROTECT 2CH 6-UDFN	MAX13202EALT+	Maxim Integrated
1	U4	MAX32625ITK+	MAX32625ITK+ 68P TQFN	MAX32625ITK+	Maxim Integrated
1	U5	MAX17270ETE+	IC REG BCK BST PROG TRPL 16TQFN	MAX17270ETE+	Maxim Integrate
1	U6	MAX1976AEZT120+T	LDO Regulator Pos 1.2V 0.3A 6-Pin TSOT-23	MAX1976AEZT120+T	Maxim Integrated
1	Y1	32 MHZ	CRYSTAL 32.0000MHZ 13PF SMD	ECS-320-13-42-CKM-TR	ECS Inc.
2	Y2 Y3	32.768kHz	CRYSTAL 32.768KHZ 6.0PF SMD	ABS07-32.768KHZ-6-T	Abracon Corp

PRELIMINARY

MAX32670 EV Kit Schematics

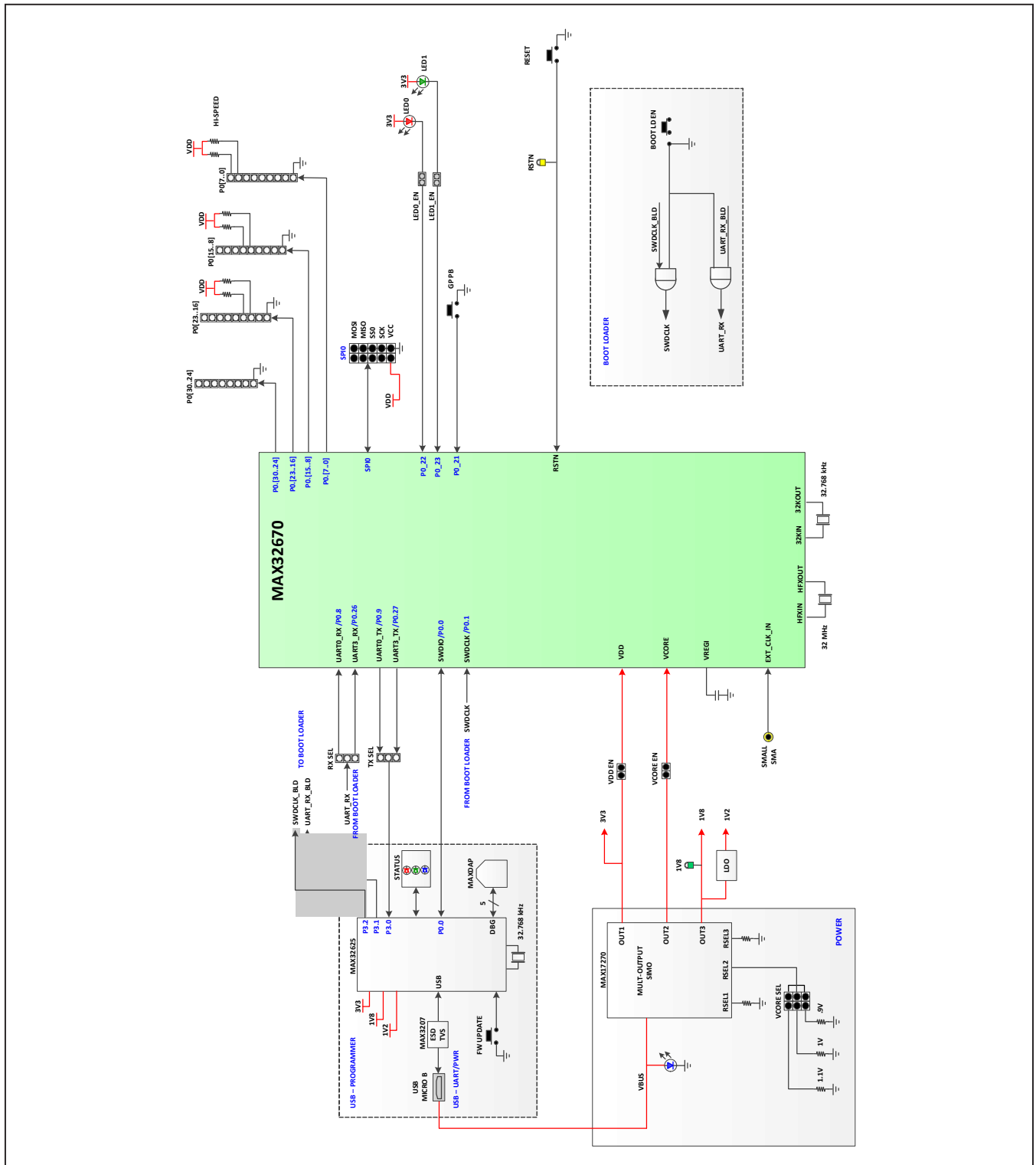

PRELIMINARY

MAX32670 EV Kit Schematics (continued)

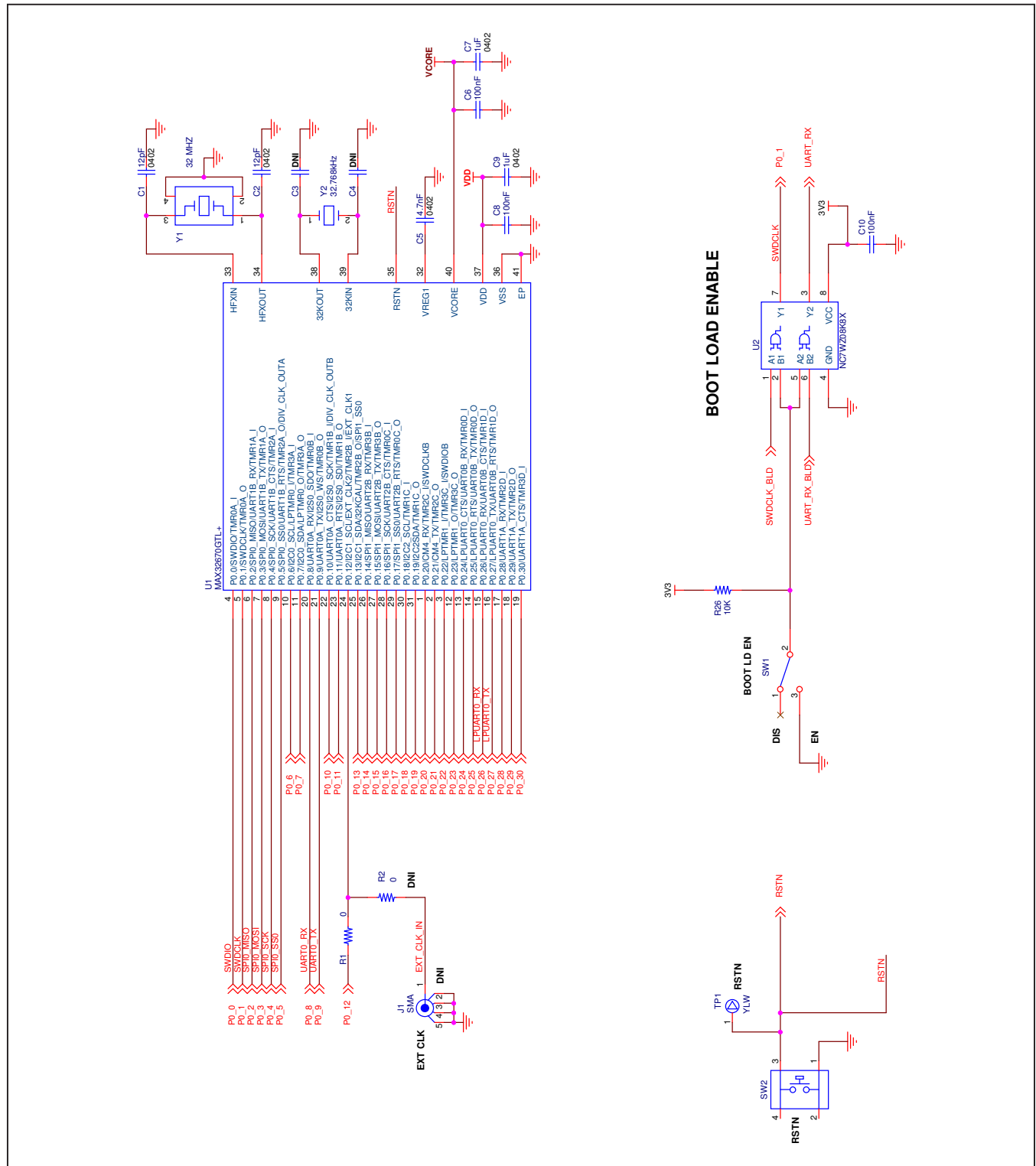

PRELIMINARY

MAX32670 EV Kit Schematics (continued)

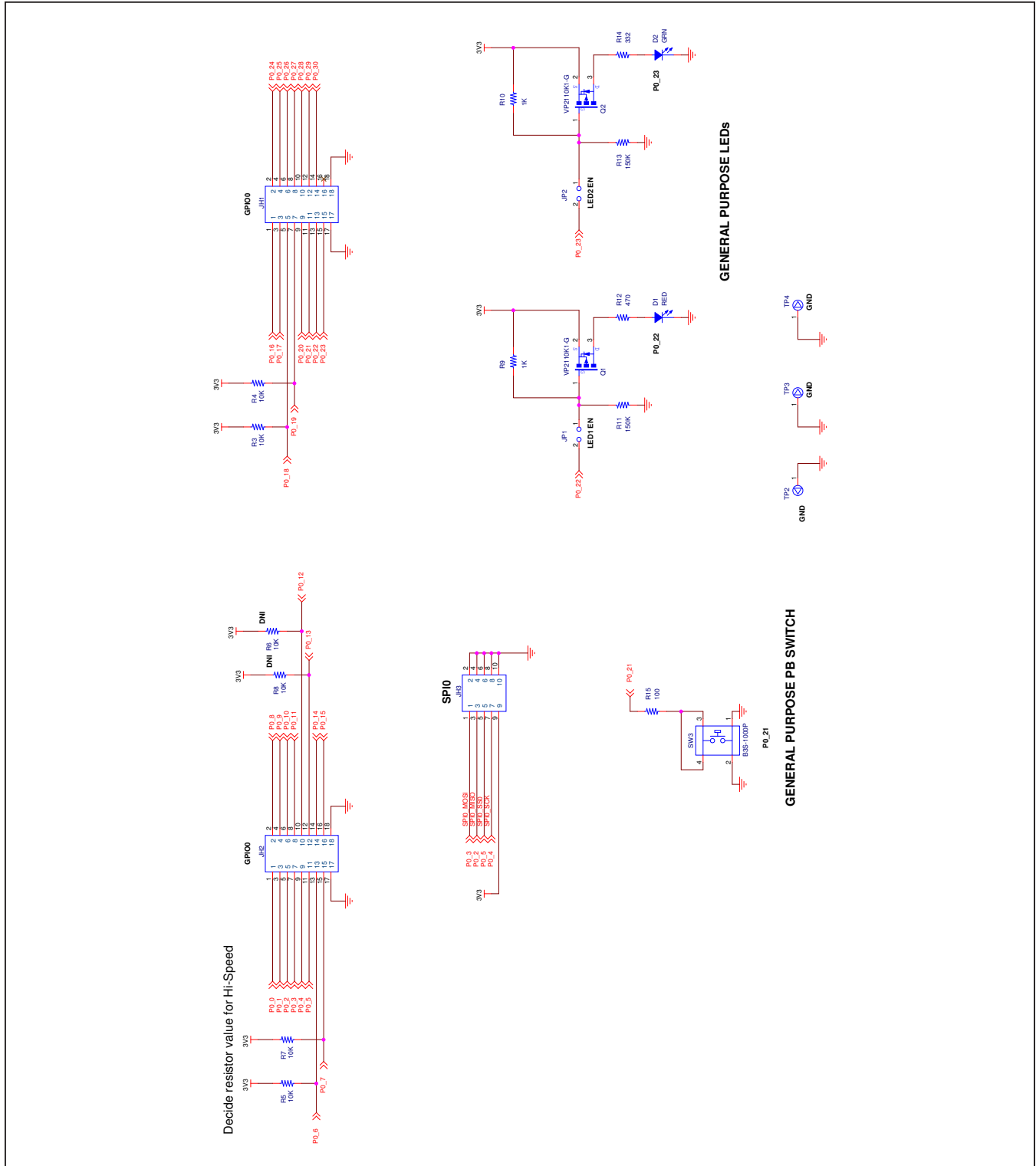

PRELIMINARY

MAX32670 EV Kit Schematics (continued)

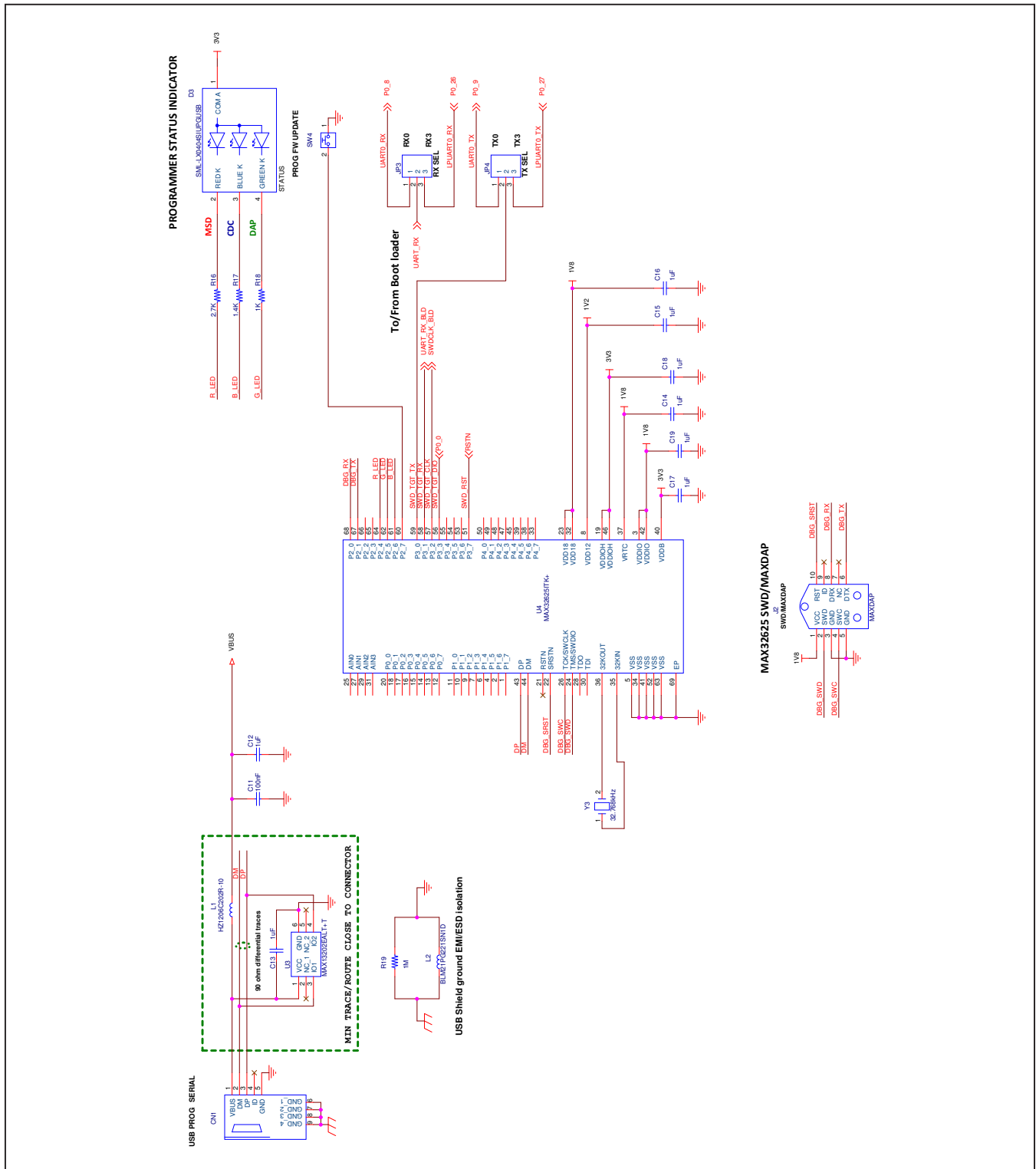

PRELIMINARY

MAX32670 EV Kit Schematics (continued)

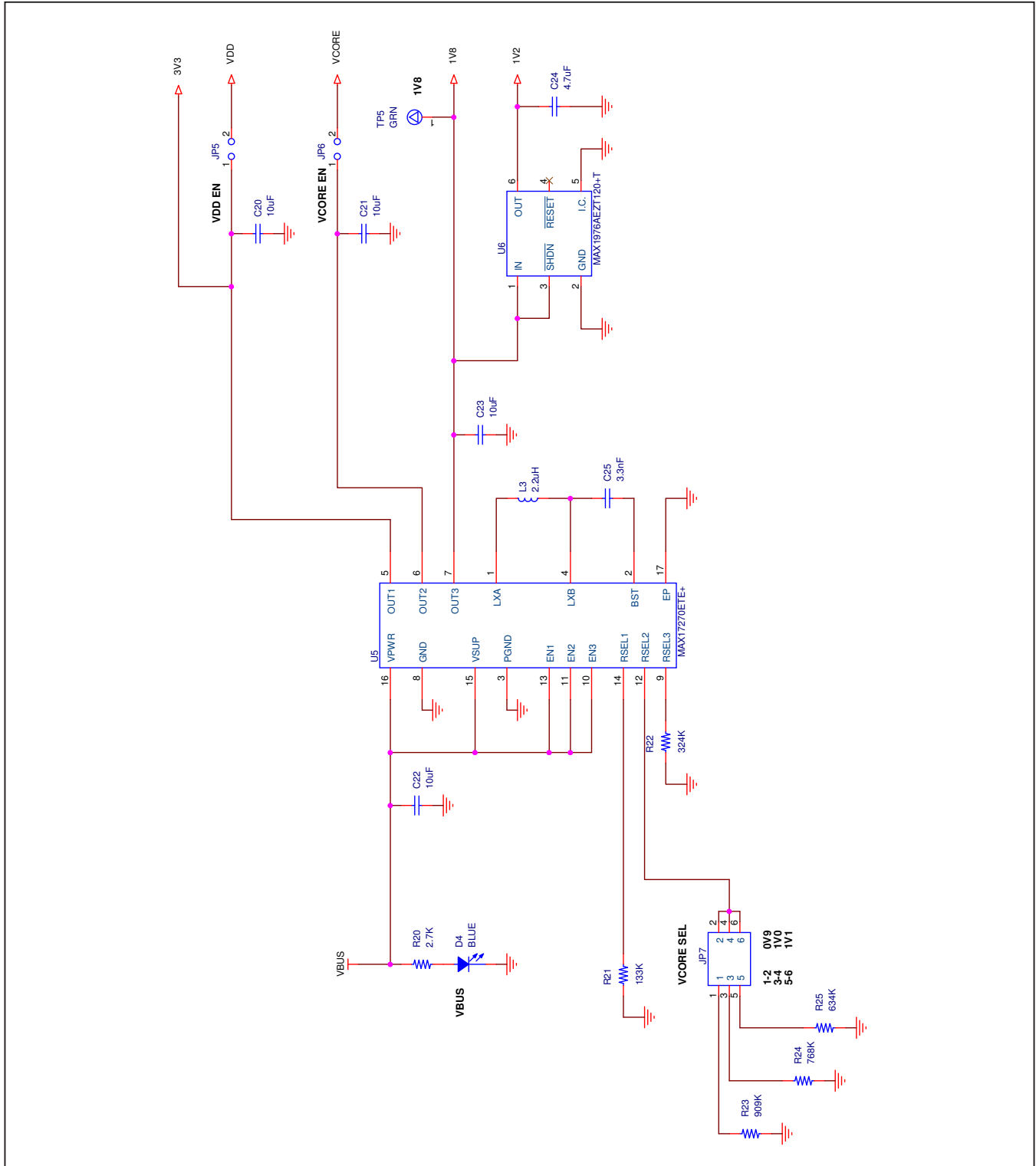

PRELIMINARY

Revision History

REVISION NUMBER	REVISION DATE	DESCRIPTION	PAGES CHANGED
0	4/20	Initial release	—

PRELIMINARY

For pricing, delivery, and ordering information, please visit Maxim Integrated's online storefront at <https://www.maximintegrated.com/en/storefront/storefront.html>.

Maxim Integrated cannot assume responsibility for use of any circuitry other than circuitry entirely embodied in a Maxim Integrated product. No circuit patent licenses are implied. Maxim Integrated reserves the right to change the circuitry and specifications without notice at any time.