

PSU-9V1A-MP

Datasheet

Table of contents

目录

Electrical Performance / 电器性能 -----	P3-P5
Product Outline / 产品外观尺寸 -----	P6
DC Cord / 线材 -----	P7
Rating Label / 铭牌 -----	P8
Packing / 包装图 -----	P9

UPDATE REV.

REV	UPDATE	DATE	PRERARATOR
Original		2015.12.21	

EDITION

版本

A0

PAGE

页码

2/9

ELECTRICAL PERFORMANCE / 电器性能

1. SAFETY STANDARD / 安规标准

1.1 The green mode power supply shall be certified by the following international regulatory standards : 电源应符合下列的国际标准 :

	Country	Certified Status	Standard / 标准
GS	Europe / 德国	APPROVED	IEC/EN 60950-1: 2005
CE	Europe / 欧洲	APPROVED	
cTUVus	USA / 美国	APPROVED	IEC/EN 60950-1: 2005
FCC	USA / 美国	APPROVED	EN 55022: 2006

2. INPUT FEATURE / 输入特性

2.1 INPUT VOLTAGE RANGE : **90Vac** to **264Vac**. 输入电压范围可以从**90Vac**到**264Vac**.

2.2 RATED INPUT VOLTAGE : **100Vac** to **240Vac**. 额定输入电压从**100Vac**到**240Vac**.

2.3 INPUT FREQUENCY RANGE : **47Hz** to **63Hz**. 输入频率范围从**47Hz**到**63Hz**.

2.4 INPUT CURRENT : **0.5A** max. (I/P100-240Vac). 最大输入电流不超过**0.5A** (输入条件100-240Vac)

2.5 INRUSH CURRENT : **27A** max. at **100-240Vac** input for a cold start at 25°C. 在标准开机条件下, 最大浪涌电流不超过**27A** (输入条件**100-240Vac**).

2.6 AVERAGE EFFICIENCY : higher than **81.3%** at 100-240Vac input and output (25%, 50%, 75% & 100% load.) 平均效率高于**81.3%** (输入100-240Vac, 输出(25%, 50%, 75% & 100%负载))

3. OUTPUT FEATURE / 输出特性

RATED OUTPUT / 额定输出 : 9VDC	SPEC. LIMIT / 规格限定		REMARK / 备注
	Min. value	Max. value	
Output regulation / 输出电压规格	8.55V DC	9.45VDC	≤ +/-5%
Output load / 输出负载规格	0.0A	1.0A	
Ripple and Noise / 输出纹波及杂讯	—	150mVp-p	20MHz Bandwidth 10uF Ele. Cap. & 0.1uF Cer. Cap
Output Overshoot / 输出过冲幅度	—	10%	
Line regulation / 电压调整率	—	+/-1%	
Load regulation / 负载调整率	—	+/-5%	
Turn-on delay time / 开机延迟时间	—	3000mS	
Hold up time / 关机维持时间	10mS	—	Input voltage:115Vac
	20mS	—	Input voltage:230Vac

4. ELECTRIC WITHSTANDING STRENGTH (HI-POT) / 绝缘介电强度 (耐压)

Primary to Secondary **AC3000V/10mA**, **1** minute for type test. **3** second for production. 一次侧对二次侧 : **AC3000V/10mA** 标准测试 **1** 分钟, 量产测试 **3** 秒钟

EDITION 版本	A0	PAGE 页码	3/9
---------------	----	------------	-----

ELECTRICAL PERFORMANCE / 电器性能

5. PROTECTION FEATURE / 保护特性

5.1 OVER – CURRENT PROTECTION / 过电流保护：

The green mode power supply shall be hiccupped when any output operating in overload condition (set @ Max load 130~200%) under any line condition for an indefinite period of time. The power supply shall be self – recovery when the fault condition is removed. 在任何时候任何输入条件，当输出操作在超载条件最大电源的 (130~200%) 时，电源供应器将进入打嗝模式，当故障被移走后，电源要能自动恢复到正常。

5.2 SHORT CIRCUIT PROTECTION / 输出短路保护：

The power supply shall be hiccupped and no damage shall occur when any output operating in a short circuit condition under any line condition for an indefinite period of time. The power supply shall be self – recovery when the fault condition is removed. 在任何时候，任何输入条件下，当输出操作在短路情况下，电源供应器将进入打嗝模式，当故障消失后，电源要能自动恢复正常。

6. ENVIRONMENTAL CONDITIONS / 环境条件

6.1 OPERATING / 操作条件：

The power supply shall be capable of operating continuously in any mode without performance deterioration in the following environmental conditions. 在下列环境条件下，电源供应器要能够连续操作在各种模式，且不能造成性能的退化。

6.1.1 Ambient Temperature : 0°C ~ 40°C 环境测度：0°C ~ 40°C

6.1.2 Relative Humidity : 10% ~ 90% 相对湿度：10% ~ 90%

6.1.3 Vibration : 1.0mm, 10 – 25Hz, 15 minutes per cycle for each axis (X, Y, Z)

6.1.4 Cooling : The power supply will operate with convection cooling. Blocking of vents must not cause damage to The power supply.

电源供应器将操作在对流冷却的环境下，即使将通风口阻塞电源也不允许有任何损伤发生。

6.2 NON – OPERATING / 非操作条件：

The power supply shall be capable of withstanding the following environmental conditions extended periods of time, without sustaining electrical or mechanical damage and subsequent operational

deficiencies : 电源供应器要能够长期的经受下列的环境条件，且不允许有电气级机械方面的损伤和并发的操作的缺失。

6.2.1 Ambient Temperature : -30°C ~ 70°C 环境温度：-30°C ~ 70°C

6.2.2 Relative Humidity : 10% ~ 90% 相对湿度：10% ~ 90%

6.2.3 Vibration and Shock / 振动和冲击

The power supply shall be designed to withstand normal transportation vibration per MIL-STD-810D, method 514 and procedures X, as it s mounted in the chassis assembly and packed for shipping. 电源供应器装配及出货的包装设计，均要能承受正常运输的振动，并符合MIL – STD – 810D 方法514 和程序 X。

EDITION

版本

A0

PAGE

页码

4/9

ELECTRICAL PERFORMANCE / 电器性能

7. EMC STANDARDS / 电磁兼容性标准

7.1 EMI STANDARDS / EMI 标准

The power supply met the radiated and conducted emission requirements for FCC CLASS B, EN55022 CLASS B. 本电源供应器符合辐射及传导要求，满足 FCC CLASS B, EN55022 CLASS B.

7.2 EMC STANDARDS / EMC 标准

The power supply shall meet the following EMC standards : 本电源供应器满足下列 EMS 标准

EN 55024: 1998+A1: 2001+A2: 2003; Part 15 Subpart B, IC ICES-003

8. Energy Saving (Level V / Level 5) 符合节能5级标准，测试标准如下：

8.1 CEC Test Report (CEC Table U-2 Standards for Power Supplies Effective July 1, 2008)

8.2 EUP Test Report (COMMISSION REGULATION (EC) No 278/2009)

8.3 MEPS (AS/NZS 4665.2-2005)

9. RELIABILITY AND QUALITY CONTROL / 可靠性及质量控制

9.1 BURN-IN / 烧机 The power supply shall undergo a minimum of 4 hours Burn-In test under full load at 40°C ~ ±5°C 电源应在 40°C ~ ±5°C 和满载条件下烘烤 4 小时。

9.2 COMPONENT DERATING / 组件温度要求 Semiconductor junction temperatures shall not exceed the manufacturer's maximum thermal rating. 半导体结温不允许超过其制造商要求的最大温度值。

10. WEIGHT / 重量 The weight of the power supply shall be about g. 电源的重量大约为 g

11. MECHANICAL REQUIREMENT / 结构参数 The power supply size : L62*W39*H32mm.

外型尺寸：L62*W39*H32mm

12. INSULATION RESISTANCE / 绝缘阻抗 Input to output : 50M OHM (500VDC)
输入对输出 50兆 欧姆 (500VDC)

13. LEAKAGE CURRENT / 漏电流 The leakage current shall be less than 0.25mA for class II when power supply is operated maximum input voltage and maximum load.
当电源供应器操作在最大输入及最大负载情况下，其漏电流应小于 0.25mA，满足 class II 等级。

14. MAJOR MEASURE EQUIPMENT / 主要测量设备

A. AC SOURCE / 交流输入电源：AFC-500W

B. POWER METER / 电源功率计：CHROMA 2100

C. ELECTRONIC LOAD / 电子负载：PRODIGIT 3310C

D. OSCILLOSCOPE / 存储示波器：TDS-2012B

E. DIGITAL MULTIMETER / 数字式万用表：Fluke 4.5

F. DC POWER / 直流输入电源：WYK-6030

G. HI-POT TESTER / 耐压测试仪：LANKE ELECTRONICS 7112

H. INSULATION RESISTANCE TESTER / 绝缘电阻表：YD2681A

EDITION

版本

A0

PAGE

页码

5/9

PRODUCT OUTLINE DIMENSION / 产品外观尺寸

Unit / 单位: mm

Tolerance / 公差: ± 0.5

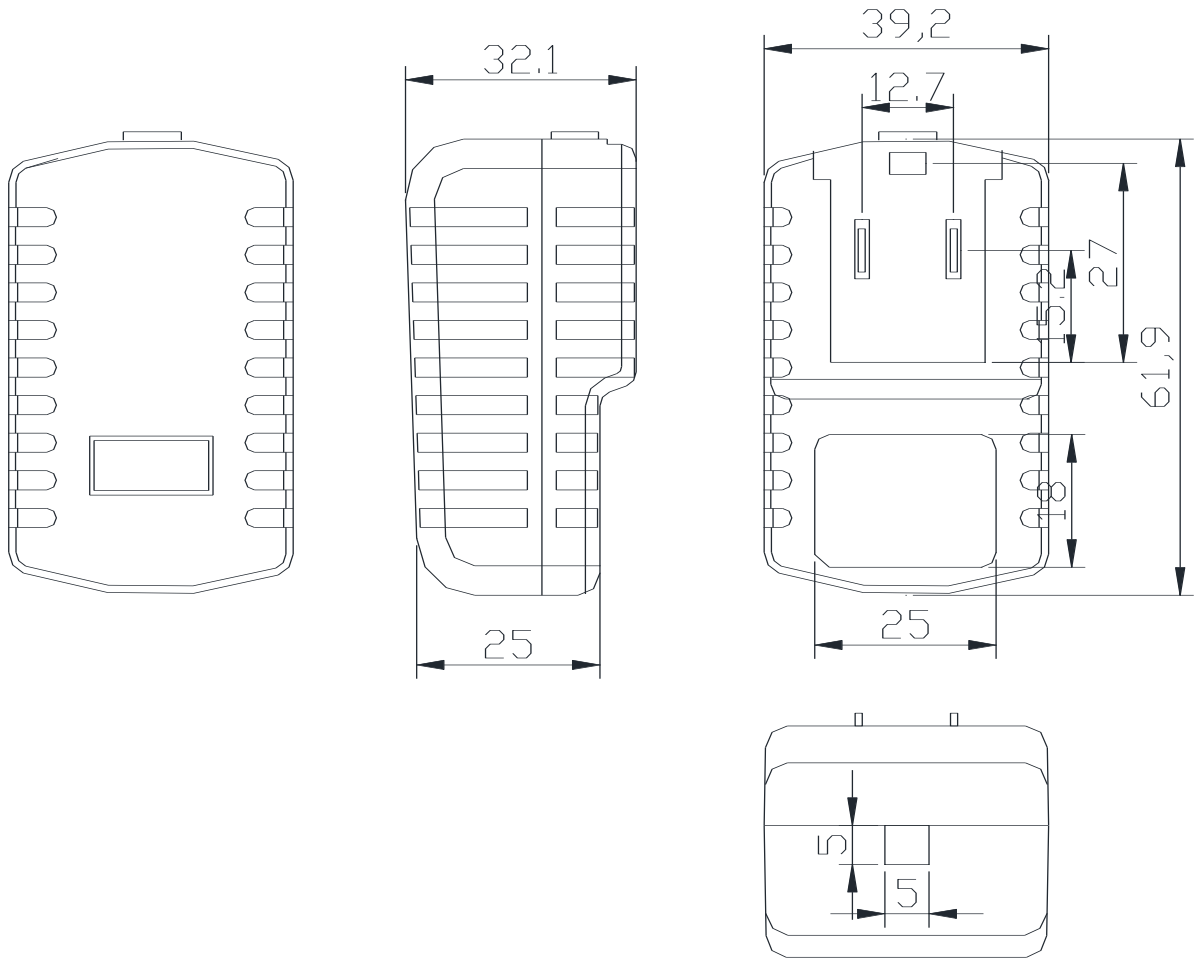

EDITION

版本

A0

PAGE

页码

6/9

DC CORD / 线材

Unit / 单位: mm

Tolerance / 公差: ± 0.5

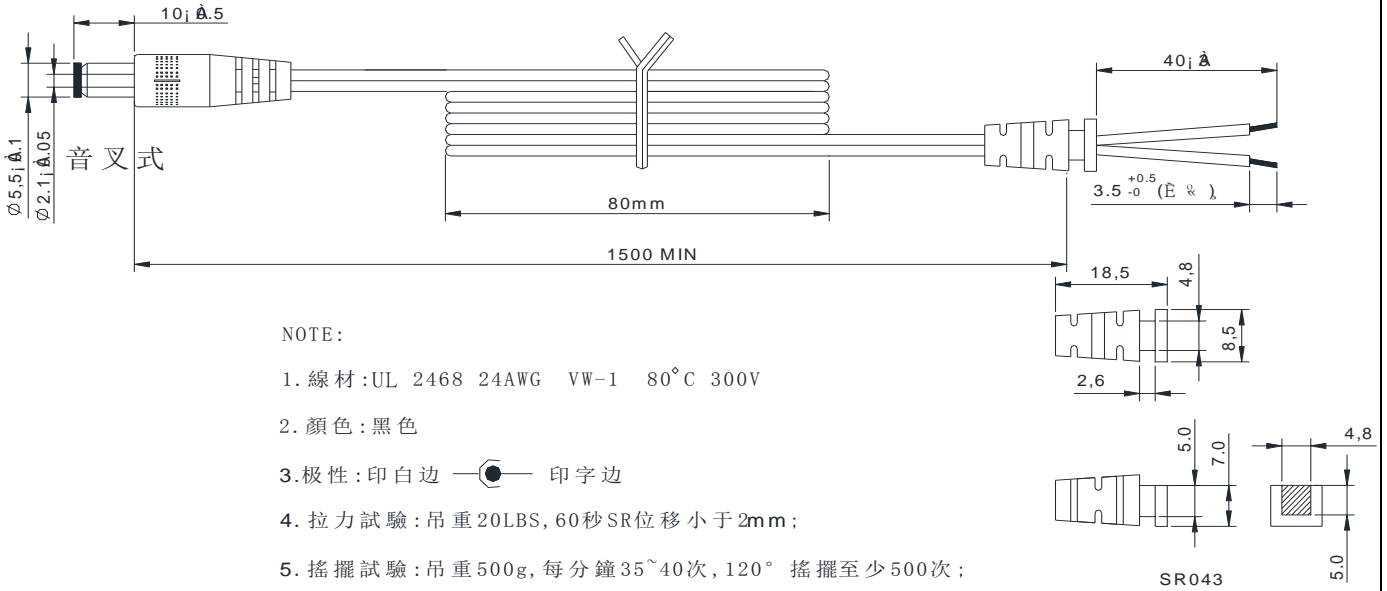

EDITION

版本

A0

PAGE

页码

7/9

RATING LABEL / 铭牌

Unit / 单位: mm

Tolerance / 公差: +0/-0.2mm

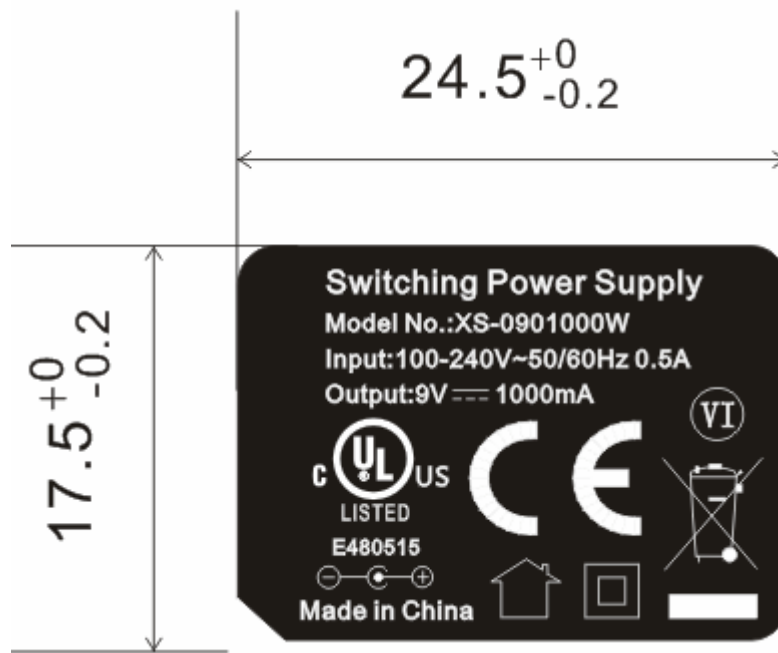

注：

1. 黑底银字-Black ground Silver text.
2. 底材为PET材质，耐温100℃ -PET materials, Temperature under 100C.
3. 丝印清晰，耐擦拭-Silk Screen printing, wipe resistance。
4. 永久背胶-Everlasting Gummed.
5. 符合环保要求-Compliance to RoHS.

EDITION

版本

A0

PAGE

页码

8/9

RATING LABEL / 包装图

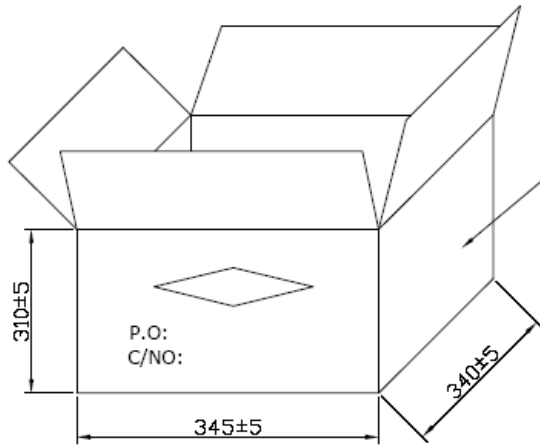
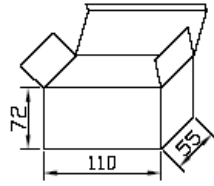

PK Carton box:A=B

MARKING A



P/N:
Q'TY: PCS
N.W.: KGS
G.W.: KGS

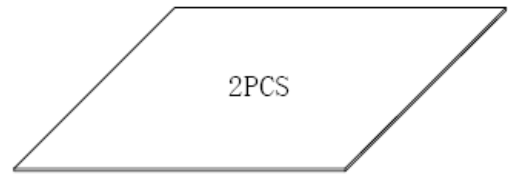

平卡 (K3K)335*330*3mm

NOTE:

1. 共4層,每層裝18PCS,每箱72PCS
2. PK箱標示尺寸為內部尺寸
3. PK箱印前後相同,左右相同,印刷顏色為黑色
4. 上,下放平卡

EDITION

版本

A0

PAGE

页码

9/9